

| | |
|-----------------------------------|---------------------------------------|
| Document Title | Specification of SPI Handler / Driver |
| Document Owner | AUTOSAR |
| Document Responsibility | AUTOSAR |
| Document Identification No | 038 |

| | |
|---------------------------------|------------------|
| Document Status | Final |
| Part of AUTOSAR Standard | Classic Platform |
| Part of Standard Release | 4.3.1 |

| Document Change History | | | |
|--------------------------------|----------------|----------------------------|---|
| Date | Release | Changed by | Change Description |
| 2017-12-08 | 4.3.1 | AUTOSAR Release Management | <ul style="list-style-type: none"> • SPI_E_SEQ_IN_PROCESS and SPI_E_SEQ_PENDING are migrated to runtime errors • The notion of prearranged bus is removed to simplify the use • Modified or removed requirements: SWS_Spi_00135, SWS_Spi_00324, SWS_Spi_00039 • Restored requirement: SWS_Spi_00035 |
| 2016-11-30 | 4.3.0 | AUTOSAR Release Management | <ul style="list-style-type: none"> • Requirements removed: SWS_Spi_00339, SWS_Spi_00191, SWS_Spi_00367, SWS_Spi_00239, SWS_Spi_00056, SWS_Spi_00076, SWS_Spi_00148 • Requirements updated: SWS_Spi_00999, SWS_Spi_00092 • Improvement of the traceability with SRS BSW General requirements • Editorial changes |
| 2015-07-31 | 4.2.2 | AUTOSAR Release Management | <ul style="list-style-type: none"> • Cleanup of requirements chapter • Debugging support marked as obsolete • Editorial changes |

| Document Change History | | | |
|-------------------------|---------|----------------------------|---|
| Date | Release | Changed by | Change Description |
| 2014-10-31 | 4.2.1 | AUTOSAR Release Management | <ul style="list-style-type: none"> Added SWS_Spi_00383, SWS_Spi_00384, SWS_Spi_00385, SWS_Spi_00386 and ECUC_Spi_00243 New configuration parameter SpiUserCallbackHeaderFile SPI hardware error is applicable for sync and async transmits Editorial changes |
| 2014-03-31 | 4.1.3 | AUTOSAR Release Management | <ul style="list-style-type: none"> Description for Spi_AsyncTransmit and Spi_SyncTransmit development errors for already ongoing transmission Clarification of Spi Channel width and data access type relation |
| 2013-10-31 | 4.1.2 | AUTOSAR Release Management | <ul style="list-style-type: none"> ECUC_Spi_00242 (added) ECUC_Spi_00240 (added) SWS_Spi_00189 (modified) Editorial changes Removed chapter(s) on change documentation |
| 2013-03-15 | 4.1.1 | AUTOSAR Administration | <ul style="list-style-type: none"> Added chapter 7.6 and 7.7, table from chapter 7.4 moved to chapter 7.7 SWS_Spi_00129 removed, SWS_Spi_00128 reformulated ECUC_Spi_00180, ECUC_Spi_00204 Length is in data elements instead of bytes MemMap header file rename Added Subchapter 3.x due to SWS General Rollout |

| Document Change History | | | |
|-------------------------|---------|------------------------|--|
| Date | Release | Changed by | Change Description |
| 2011-12-22 | 4.0.3 | AUTOSAR Administration | <ul style="list-style-type: none"> • Rephrased: requirement SWS_Spi_00002, SWS_Spi_00046, SWS_Spi_00129, SWS_Spi_00233, SWS_Spi_00163, SPI 171, SWS_Spi_00172, SWS_Spi_00289 and SWS_Spi_00290, block 2 in chapter 7.2.2 • Removed: requirement SPI083; SPI132, SPI284 and SPI107 removed from statement • Corrected: Dem_EventStatusType in SWS_Spi_00191, Spi_SyncTransmit Syn/Async changed to Synchronous, SPI_E_PARAM_POINTER in SWS_Spi_00371, • Reference to MCU in SWS_Spi_00244 and SWS_Spi_00342 • Added: requirement SWS_Spi_00140, chapter 10 - SpiCsSelection, SWS_Spi_00194 - SPI_JOB_QUEUED state introduced, SWS_Spi_00195 with error table update • Modified: SWS_Spi_00114 and SWS_Spi_00135, chapter 10 - SpiEnableCs |
| 2010-09-30 | 3.1.5 | AUTOSAR Administration | <ul style="list-style-type: none"> • Added SWS_Spi_00369, SWS_Spi_00371, SWS_Spi_00370 • Removed SPI190, SPI094 • Updated configuration: base on min-max value for defined parameter; SpiHwUnit belongs to SpiExternalDevice Container; updated SpiTimeClk2Cs |

| Document Change History | | | |
|--------------------------------|----------------|------------------------|--|
| Date | Release | Changed by | Change Description |
| 2010-02-02 | 3.1.4 | AUTOSAR Administration | <ul style="list-style-type: none"> • Splitting and refinement of several requirements • Removal of redundant requirements • Introduction of new IDs to allow implementation of debugging concept • Inserted UML diagram in chapter 9 • Updating of Chapter 10 with the inclusion of 2 new container and the definition of the Chip Select configuration • Legal disclaimer revised |
| 2008-08-13 | 3.1.1 | AUTOSAR Administration | <ul style="list-style-type: none"> • Legal disclaimer revised |
| 2007-12-21 | 3.0.1 | AUTOSAR Administration | <ul style="list-style-type: none"> • Updated Chapter 10 with the inclusion of CS configuration • Document meta information extended • Small layout adaptations made |
| 2007-01-24 | 2.1.15 | AUTOSAR Administration | <ul style="list-style-type: none"> • Configuration Specification updating • General rephrasing for clarification • Syntax error • Legal disclaimer revised • Release Notes added • “Advice for users” revised • “Revision Information” added |
| 2006-05-16 | 2.0 | AUTOSAR Administration | <ul style="list-style-type: none"> • Document structure adapted to common Release 2.0 SWS Template. • Major changes in chapter 10 • Structure of document changed partly • Other changes see chapter 13 |
| 2005-05-31 | 1.0 | AUTOSAR Administration | <ul style="list-style-type: none"> • Initial Release |

Disclaimer

This work (specification and/or software implementation) and the material contained in it, as released by AUTOSAR, is for the purpose of information only. AUTOSAR and the companies that have contributed to it shall not be liable for any use of the work.

The material contained in this work is protected by copyright and other types of intellectual property rights. The commercial exploitation of the material contained in this work requires a license to such intellectual property rights.

This work may be utilized or reproduced without any modification, in any form or by any means, for informational purposes only. For any other purpose, no part of the work may be utilized or reproduced, in any form or by any means, without permission in writing from the publisher.

The work has been developed for automotive applications only. It has neither been developed, nor tested for non-automotive applications.

The word AUTOSAR and the AUTOSAR logo are registered trademarks.

Table of Contents

| | | |
|-------|--|----|
| 1 | Introduction and functional overview | 10 |
| 2 | Acronyms and abbreviations | 11 |
| 3 | Related documentation..... | 12 |
| 3.1 | Input documents..... | 12 |
| 3.2 | Related standards and norms | 12 |
| 3.3 | Related specification | 13 |
| 4 | Constraints and assumptions | 13 |
| 4.1 | Limitations | 13 |
| 4.2 | Applicability to car domains..... | 13 |
| 5 | Dependencies to other modules..... | 14 |
| 5.1 | File structure | 14 |
| 5.1.1 | Header file structure | 14 |
| 6 | Requirements traceability | 16 |
| 7 | Functional specification | 23 |
| 7.1 | Overall view of functionalities and features | 23 |
| 7.2 | General behaviour..... | 24 |
| 7.2.1 | Common configurable feature: Allowed Channel Buffers..... | 27 |
| 7.2.2 | LEVEL 0, Simple Synchronous behaviour | 28 |
| 7.2.3 | LEVEL 1, Basic Asynchronous behavior | 29 |
| 7.2.4 | Asynchronous configurable feature: Interruptible Sequences | 31 |
| 7.2.5 | LEVEL 2, Enhanced behaviour | 33 |
| 7.3 | Scheduling Advices | 34 |
| 7.4 | Error classification | 34 |
| 7.4.1 | Development Errors | 35 |
| 7.4.2 | Runtime Errors | 35 |
| 7.4.3 | Transient faults..... | 36 |
| 7.4.4 | Production Errors | 36 |
| 7.4.5 | Extended Production Errors | 36 |
| 7.5 | Error detection..... | 36 |
| 7.5.1 | API parameter checking | 36 |
| 7.5.2 | SPI state checking | 37 |
| 8 | API specification..... | 38 |
| 8.1 | Imported types..... | 38 |
| 8.2 | Type definitions | 38 |
| 8.2.1 | Spi_ConfigType..... | 38 |
| 8.2.2 | Spi_StatusType..... | 39 |
| 8.2.3 | Spi_JobResultType | 40 |
| 8.2.4 | Spi_SeqResultType | 41 |
| 8.2.5 | Spi_DataBufferType | 41 |
| 8.2.6 | Spi_NumberOfDataType | 42 |
| 8.2.7 | Spi_ChannelType..... | 42 |
| 8.2.8 | Spi_JobType | 42 |
| 8.2.9 | Spi_SequenceType..... | 42 |

| | | |
|--------|---|----|
| 8.2.10 | Spi_HWUnitType..... | 43 |
| 8.2.11 | Spi_AsyncModeType | 43 |
| 8.3 | Function definitions | 44 |
| 8.3.1 | Spi_Init | 44 |
| 8.3.2 | Spi_DeInit..... | 45 |
| 8.3.3 | Spi_WriteIB | 46 |
| 8.3.4 | Spi_AsyncTransmit | 47 |
| 8.3.5 | Spi_ReadIB..... | 49 |
| 8.3.6 | Spi_SetupEB..... | 50 |
| 8.3.7 | Spi_GetStatus | 52 |
| 8.3.8 | Spi_GetJobResult | 52 |
| 8.3.9 | Spi_GetSequenceResult..... | 53 |
| 8.3.10 | Spi_GetVersionInfo | 54 |
| 8.3.11 | Spi_SyncTransmit..... | 54 |
| 8.3.12 | Spi_GetHWUnitStatus..... | 55 |
| 8.3.13 | Spi_Cancel..... | 56 |
| 8.3.14 | Spi_SetAsyncMode..... | 57 |
| 8.4 | Callback notifications..... | 58 |
| 8.5 | Scheduled functions..... | 58 |
| 8.5.1 | Spi_MainFunction_Handling | 58 |
| 8.6 | Expected Interfaces..... | 59 |
| 8.6.1 | Mandatory Interfaces | 59 |
| 8.6.2 | Optional Interfaces | 59 |
| 8.6.3 | Configurable interfaces | 59 |
| 9 | Sequence diagrams | 62 |
| 9.1 | Initialization | 62 |
| 9.2 | Modes transitions | 62 |
| 9.3 | Write/AsyncTransmit/Read (IB)..... | 63 |
| 9.3.1 | One Channel, one Job then one Sequence | 63 |
| 9.3.2 | Many Channels, one Job then one Sequence | 65 |
| 9.3.3 | Many Channels, many Jobs and one Sequence..... | 66 |
| 9.3.4 | Many Channels, many Jobs and many Sequences | 68 |
| 9.4 | Setup/AsyncTransmit (EB)..... | 69 |
| 9.4.1 | Variable Number of Data / Constant Number of Data | 70 |
| 9.4.2 | One Channel, one Job then one Sequence | 70 |
| 9.4.3 | Many Channels, one Job then one Sequence | 71 |
| 9.4.4 | Many Channels, many Jobs and one Sequence..... | 72 |
| 9.4.5 | Many Channels, many Jobs and many Sequences | 74 |
| 9.5 | Mixed Jobs Transmission..... | 75 |
| 9.6 | LEVEL 0 SyncTransmit diagrams..... | 76 |
| 9.6.1 | Write/SyncTransmit/Read (IB): Many Channels, many Jobs and one Sequence | 76 |
| 9.6.2 | Setup/SyncTransmit (EB): Many Channels, many Jobs and one Sequence | 77 |
| 10 | Configuration specification..... | 78 |
| 10.1 | How to read this chapter | 78 |
| 10.2 | Containers and configuration parameters | 78 |
| 10.2.1 | Spi..... | 78 |
| 10.2.2 | SpiDemEventParameterRefs | 78 |

| | | |
|---------|-----------------------------------|----|
| 10.2.3 | SpiGeneral | 79 |
| 10.2.4 | SpiSequence | 82 |
| 10.2.5 | SpiChannel | 83 |
| 10.2.6 | SpiChannelList | 86 |
| 10.2.7 | SpiJob | 86 |
| 10.2.8 | SpiExternalDevice | 88 |
| 10.2.9 | SpiDriver | 91 |
| 10.2.10 | SpiPublishedInformation | 92 |
| 10.3 | Published information | 93 |
| 10.4 | Configuration concept | 93 |
| 11 | Not applicable requirements | 95 |
| 12 | Appendix | 96 |

1 Introduction and functional overview

The SPI Handler/Driver provides services for reading from and writing to devices connected via SPI busses. It provides access to SPI communication to several users (e.g. EEPROM, Watchdog, I/O ASICs). It also provides the required mechanism to configure the onchip SPI peripheral.

This specification describes the API for a monolithic SPI Handler/Driver. This software module includes handling and driving functionalities. Main objectives of this monolithic SPI Handler/Driver are to take the best of each microcontroller features and to allow implementation optimization depending on static configuration to fit as much as possible to ECU needs.

Hence, this specification defines selectable levels of functionalities and configurable features to allow the design of a high scalable module that exploits the peculiarities of the microcontroller.

To configure the SPI Handler/Driver these steps shall be followed:

- SPI Handler/Driver Level of Functionality shall be selected and optional features configured.
- SPI Channels shall be defined according to data usage, and they could be buffered inside the SPI Handler/Driver (IB) or provided by the user (EB).
- SPI Jobs shall be defined according to HW properties (CS), and they will contain a list of channels using those properties.
- As a final step, Sequences of Jobs shall be defined, in order to transmit data in a sorted way (priority sorted).

The general behaviour of the SPI Handler/Driver can be asynchronous or synchronous according to the Level of Functionality selected.

The specification covers the Handler/Driver functionality combined in one single module. One is the SPI handling part that handles multiple access to busses that could be located in the ECU Abstraction layer. The other part is the SPI driver that accesses the microcontroller hardware directly that could be located in the Microcontroller Abstraction layer.

2 Acronyms and abbreviations

Acronyms and abbreviations which have a local scope and therefore are not contained in the AUTOSAR glossary must appear in a local glossary.

| Acronym: | Description: |
|-----------------|---|
| DET | Default Error Tracer – module to which errors are reported. |
| DEM | Diagnostic Event Manager – module to which production relevant errors are reported. |
| SPI | Serial Peripheral Interface. It is exactly defined hereafter in this document. |
| CS | Chip Select |
| MISO | Master Input Slave Output |
| MOSI | Master Output Slave Input |

| Abbreviation: | Description: |
|----------------------|---|
| EB | Externally buffered channels. Buffers containing data to transfer are outside the SPI Handler/Driver. |
| IB | Internally buffered channels. Buffers containing data to transfer are inside the SPI Handler/Driver. |
| ID | Identification Number of an element (Channel, Job, Sequence). |

| Definition: | Description: |
|--------------------|---|
| Channel | A Channel is a software exchange medium for data that are defined with the same criteria: Config. Parameters, Number of Data elements with same size and data pointers (Source & Destination) or location. |
| Job | A Job is composed of one or several Channels with the same Chip Select (is not released during the processing of Job). A Job is considered atomic and therefore cannot be interrupted by another Job. A Job has an assigned priority. |
| Sequence | A Sequence is a number of consecutive Jobs to transmit but it can be rescheduled between Jobs using a priority mechanism. A Sequence transmission is interruptible (by another Sequence transmission) or not depending on a static configuration. |

3 Related documentation

3.1 Input documents

- [1] Layered Software Architecture
AUTOSAR_EXP_LayeredSoftwareArchitecture.pdf
- [2] General Requirements on SPAL
AUTOSAR_SRS_SPALGeneral.pdf
- [3] General Requirements on Basic Software Modules
AUTOSAR_SRS_BSWGeneral.pdf
- [4] Specification of Default Error Tracer
AUTOSAR_SWS_DefaultErrorTracer.pdf
- [5] Specification of ECU Configuration
AUTOSAR_TPS_ECUConfiguration.pdf
- [6] Requirements on SPI Handler/Driver
AUTOSAR_SRS_SPIHandlerDriver.pdf
- [7] Specification of Diagnostic Event Manager
AUTOSAR_SWS_DiagnosticEventManager.pdf
- [8] Glossary
AUTOSAR_TR_Glossary.pdf
- [9] Specification of MCU Driver
AUTOSAR_SWS_MCUDriver .pdf
- [10] Specification of PORT Driver
AUTOSAR_SWS_PORTDriver
- [11] Basic Software Module Description Template,
AUTOSAR_TPS_BSWModuleDescriptionTemplate.pdf
- [12] List of Basic Software Modules
AUTOSAR_TR_BSWModuleList
- [13] Specification of Standard Types,
AUTOSAR_SWS_StandardTypes.pdf
- [14] General Specification of Basic Software Modules
AUTOSAR_SWS_BSWGeneral.pdf

3.2 Related standards and norms

Not related.

3.3 Related specification

AUTOSAR provides a General Specification on Basic Software modules [14] (SWS BSW General), which is also valid for SPI Handler Driver.

Thus, the specification SWS BSW General shall be considered as additional and required specification for SPI Handler Driver.

4 Constraints and assumptions

4.1 Limitations

[SWS_Spi_00040] [The SPI Handler/Driver handles only the Master mode.] ()

[SWS_Spi_00050] [The SPI Handler/Driver only supports full-duplex mode.] ()

[SWS_Spi_00108] [The LEVEL 2 SPI Handler/Driver is specified for microcontrollers that have to provide, at least, two SPI busses using separated hardware units. Otherwise, using this level of functionality does not make sense.] ()

4.2 Applicability to car domains

No restrictions.

5 Dependencies to other modules

[SWS_Spi_00244] [The SPI Handler/Driver module does not take care of setting the registers which configure the clock, prescaler(s) and PLL in its init function. This has to be done by the MCU module [9].] ()

Note: SPI peripherals may depend on the system clock, prescaler(s) and PLL. Thus, any change of the system clock (e.g. PLL on / PLL off / clock dividers) may also affect the clock settings of the SPI hardware.

[SWS_Spi_00342] [Depending on microcontrollers, the SPI peripheral could share registers with other peripherals. In this typical case, the SPI Handler/Driver has a relationship with MCU module [9] for initialising and de-initialising those registers.] ()

[SWS_Spi_00343] [If Chip Selects are done using microcontroller pins the SPI Handler/Driver has a relationship with PORT module [10]. In this case, this specification assumes that these microcontroller pins are directly accessed by the SPI Handler/Driver module without using APIs of DIO module. Anyhow, the SPI depends on ECU hardware design and for that reason it may depend on other modules.] ()

5.1 File structure

5.1.1 Header file structure

[SWS_Spi_00092] [The SPI module shall adhere to the following include file structure:

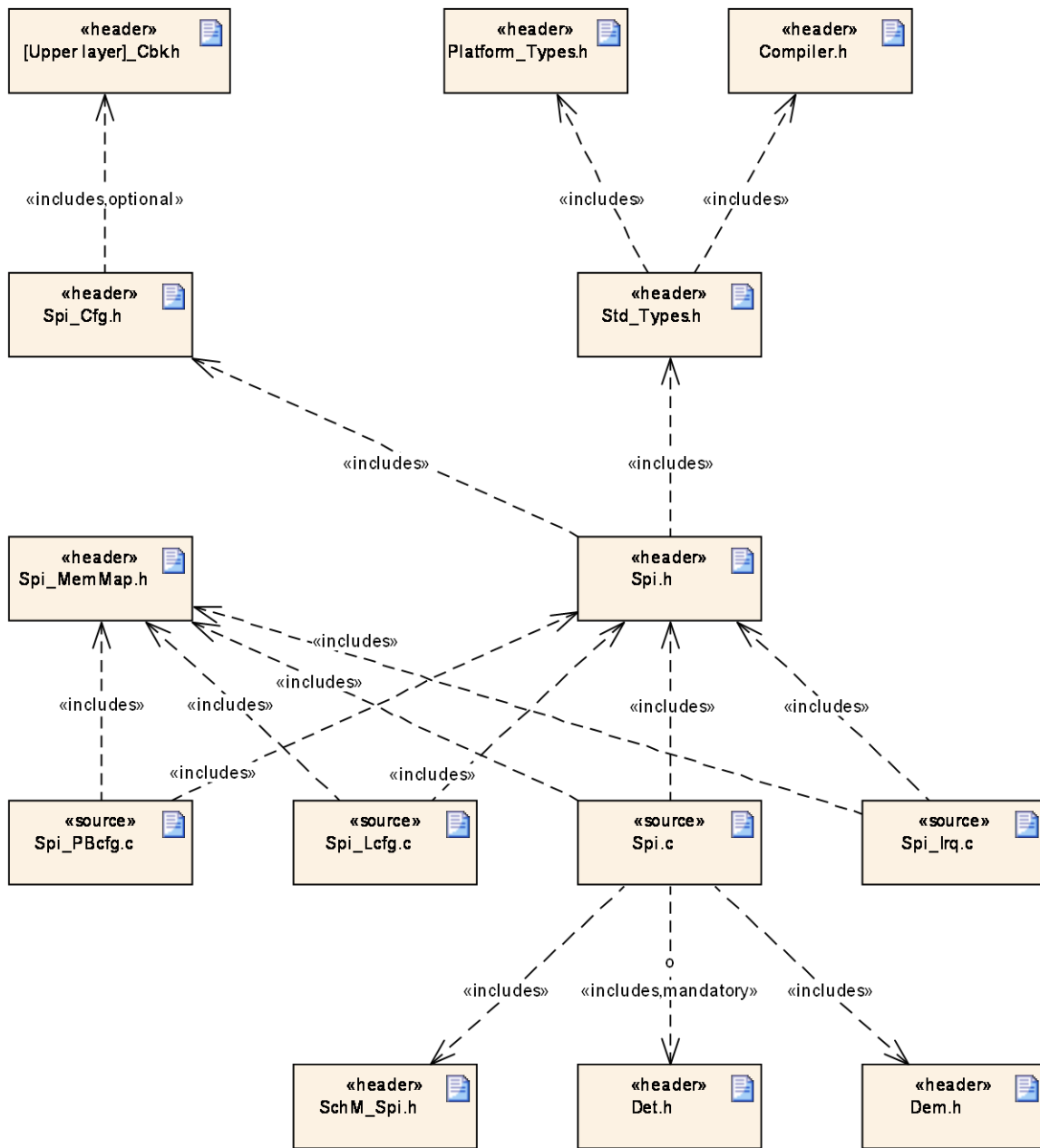

] (SRS_BSW_00412, SRS_BSW_00415)

[SWS_Spi_00159] [The DEM configuration tool shall assign ECU dependent values to the Event Id symbols and publish the symbols in Dem_IntErrId.h.] (SRS_BSW_00384)

The names of the Event Id symbols which are provided by XML to the DEM configuration tool are specified in this document.

6 Requirements traceability

| Requirement | Description | Satisfied by |
|---------------|--|------------------------------|
| SRS_BSW_00005 | Modules of the μ C Abstraction Layer (MCAL) may not have hard coded horizontal interfaces | SWS_Spi_00999 |
| SRS_BSW_00006 | The source code of software modules above the μ C Abstraction Layer (MCAL) shall not be processor and compiler dependent. | SWS_Spi_00999 |
| SRS_BSW_00009 | All Basic SW Modules shall be documented according to a common standard. | SWS_Spi_00999 |
| SRS_BSW_00010 | The memory consumption of all Basic SW Modules shall be documented for a defined configuration for all supported platforms. | SWS_Spi_00999 |
| SRS_BSW_00101 | The Basic Software Module shall be able to initialize variables and hardware in a separate initialization function | SWS_Spi_00013, SWS_Spi_00015 |
| SRS_BSW_00161 | The AUTOSAR Basic Software shall provide a microcontroller abstraction layer which provides a standardized interface to higher software layers | SWS_Spi_00999 |
| SRS_BSW_00164 | The Implementation of interrupt service routines shall be done by the Operating System, complex drivers or modules | SWS_Spi_00999 |
| SRS_BSW_00168 | SW components shall be tested by a function defined in a common API in the Basis-SW | SWS_Spi_00999 |
| SRS_BSW_00170 | The AUTOSAR SW Components shall provide information about their dependency from faults, signal qualities, driver demands | SWS_Spi_00999 |
| SRS_BSW_00172 | The scheduling strategy that is built inside the Basic Software Modules shall be compatible with the strategy used in the system | SWS_Spi_00999 |
| SRS_BSW_00301 | All AUTOSAR Basic Software Modules shall only import the necessary information | SWS_Spi_00999 |
| SRS_BSW_00302 | All AUTOSAR Basic Software Modules shall only export information needed by other modules | SWS_Spi_00999 |
| SRS_BSW_00306 | AUTOSAR Basic Software Modules shall be compiler and platform independent | SWS_Spi_00999 |
| SRS_BSW_00307 | Global variables naming convention | SWS_Spi_00999 |

| | | |
|---------------|--|--|
| SRS_BSW_00308 | AUTOSAR Basic Software Modules shall not define global data in their header files, but in the C file | SWS_Spi_00999 |
| SRS_BSW_00309 | All AUTOSAR Basic Software Modules shall indicate all global data with read-only purposes by explicitly assigning the const keyword | SWS_Spi_00999 |
| SRS_BSW_00312 | Shared code shall be reentrant | SWS_Spi_00999 |
| SRS_BSW_00323 | All AUTOSAR Basic Software Modules shall check passed API parameters for validity | SWS_Spi_00031, SWS_Spi_00032, SWS_Spi_00060 |
| SRS_BSW_00325 | The runtime of interrupt service routines and functions that are running in interrupt context shall be kept short | SWS_Spi_00999 |
| SRS_BSW_00327 | Error values naming convention | SWS_Spi_00004 |
| SRS_BSW_00328 | All AUTOSAR Basic Software Modules shall avoid the duplication of code | SWS_Spi_00999 |
| SRS_BSW_00330 | It shall be allowed to use macros instead of functions where source code is used and runtime is critical | SWS_Spi_00999 |
| SRS_BSW_00331 | All Basic Software Modules shall strictly separate error and status information | SWS_Spi_00999 |
| SRS_BSW_00334 | All Basic Software Modules shall provide an XML file that contains the meta data | SWS_Spi_00999 |
| SRS_BSW_00335 | Status values naming convention | SWS_Spi_00019, SWS_Spi_00061, SWS_Spi_00062, SWS_Spi_00373 |
| SRS_BSW_00336 | Basic SW module shall be able to shutdown | SWS_Spi_00021, SWS_Spi_00022 |
| SRS_BSW_00337 | Classification of development errors | SWS_Spi_00004 |
| SRS_BSW_00341 | Module documentation shall contains all needed informations | SWS_Spi_00999 |
| SRS_BSW_00342 | It shall be possible to create an AUTOSAR ECU out of modules provided as source code and modules provided as object code, even mixed | SWS_Spi_00999 |
| SRS_BSW_00343 | The unit of time for specification and configuration of Basic SW modules shall be preferably in physical time unit | SWS_Spi_00999 |
| SRS_BSW_00344 | BSW Modules shall support link-time configuration | SWS_Spi_00009 |
| SRS_BSW_00347 | A Naming separation of different instances of BSW drivers shall be in place | SWS_Spi_00999 |
| SRS_BSW_00357 | For success/failure of an API call a standard return type shall be defined | SWS_Spi_00174 |
| SRS_BSW_00359 | All AUTOSAR Basic Software Modules callback functions shall avoid return types other than void if possible | SWS_Spi_00048 |

| | | |
|---------------|--|---|
| SRS_BSW_00360 | AUTOSAR Basic Software Modules callback functions are allowed to have parameters | SWS_Spi_00048 |
| SRS_BSW_00369 | All AUTOSAR Basic Software Modules shall not return specific development error codes via the API | SWS_Spi_00048 |
| SRS_BSW_00375 | Basic Software Modules shall report wake-up reasons | SWS_Spi_00999 |
| SRS_BSW_00384 | The Basic Software Module specifications shall specify at least in the description which other modules they require | SWS_Spi_00159 |
| SRS_BSW_00385 | List possible error notifications | SWS_Spi_00004 |
| SRS_BSW_00399 | Parameter-sets shall be located in a separate segment and shall be loaded after the code | SWS_Spi_00999 |
| SRS_BSW_00400 | Parameter shall be selected from multiple sets of parameters after code has been loaded and started | SWS_Spi_00999 |
| SRS_BSW_00401 | Documentation of multiple instances of configuration parameters shall be available | SWS_Spi_00999 |
| SRS_BSW_00405 | BSW Modules shall support multiple configuration sets | SWS_Spi_00008, SWS_Spi_00013 |
| SRS_BSW_00406 | A static status variable denoting if a BSW module is initialized shall be initialized with value 0 before any APIs of the BSW module is called | SWS_Spi_00015, SWS_Spi_00046, SWS_Spi_00373 |
| SRS_BSW_00412 | References to c-configuration parameters shall be placed into a separate h-file | SWS_Spi_00092 |
| SRS_BSW_00413 | An index-based accessing of the instances of BSW modules shall be done | SWS_Spi_00999 |
| SRS_BSW_00415 | Interfaces which are provided exclusively for one module shall be separated into a dedicated header file | SWS_Spi_00092 |
| SRS_BSW_00416 | The sequence of modules to be initialized shall be configurable | SWS_Spi_00999 |
| SRS_BSW_00417 | Software which is not part of the SW-C shall report error events only after the DEM is fully operational. | SWS_Spi_00999 |
| SRS_BSW_00422 | Pre-de-bouncing of error status information is done within the DEM | SWS_Spi_00999 |
| SRS_BSW_00423 | BSW modules with AUTOSAR interfaces shall be describable with the means of the SW-C Template | SWS_Spi_00999 |
| SRS_BSW_00424 | BSW module main processing functions shall not be allowed to enter a wait state | SWS_Spi_00999 |

| | | |
|----------------|--|--|
| SRS_BSW_00426 | BSW Modules shall ensure data consistency of data which is shared between BSW modules | SWS_Spi_00999 |
| SRS_BSW_00427 | ISR functions shall be defined and documented in the BSW module description template | SWS_Spi_00999 |
| SRS_BSW_00428 | A BSW module shall state if its main processing function(s) has to be executed in a specific order or sequence | SWS_Spi_00999 |
| SRS_BSW_00429 | Access to OS is restricted | SWS_Spi_00999 |
| SRS_BSW_00432 | Modules should have separate main processing functions for read/receive and write/transmit data path | SWS_Spi_00999 |
| SRS_BSW_00433 | Main processing functions are only allowed to be called from task bodies provided by the BSW Scheduler | SWS_Spi_00999 |
| SRS_SPAL_00157 | All drivers and handlers of the AUTOSAR Basic Software shall implement notification mechanisms of drivers and handlers | SWS_Spi_00026, SWS_Spi_00038, SWS_Spi_00042, SWS_Spi_00057, SWS_Spi_00071, SWS_Spi_00073, SWS_Spi_00075, SWS_Spi_00324 |
| SRS_SPAL_12056 | All driver modules shall allow the static configuration of notification mechanism | SWS_Spi_00009, SWS_Spi_00044, SWS_Spi_00054, SWS_Spi_00064 |
| SRS_SPAL_12057 | All driver modules shall implement an interface for initialization | SWS_Spi_00013, SWS_Spi_00015 |
| SRS_SPAL_12063 | All driver modules shall only support raw value mode | SWS_Spi_00999 |
| SRS_SPAL_12064 | All driver modules shall raise an error if the change of the operation mode leads to degradation of running operations | SWS_Spi_00021, SWS_Spi_00025 |
| SRS_SPAL_12067 | All driver modules shall set their wake-up conditions depending on the selected operation mode | SWS_Spi_00999 |
| SRS_SPAL_12068 | The modules of the MCAL shall be initialized in a defined sequence | SWS_Spi_00999 |
| SRS_SPAL_12069 | All drivers of the SPAL that wake up from a wake-up interrupt shall report the wake-up reason | SWS_Spi_00999 |
| SRS_SPAL_12075 | All drivers with random streaming capabilities shall use application buffers | SWS_Spi_00053 |
| SRS_SPAL_12077 | All drivers shall provide a non blocking implementation | SWS_Spi_00999 |
| SRS_SPAL_12078 | The drivers shall be coded in a way that is most efficient in terms of memory and runtime resources | SWS_Spi_00999 |
| SRS_SPAL_12092 | The driver's API shall be accessed by its handler or manager | SWS_Spi_00999 |
| SRS_SPAL_12125 | All driver modules shall only initialize the configured resources | SWS_Spi_00008, SWS_Spi_00009, SWS_Spi_00013 |

| | | |
|----------------|---|--|
| SRS_SPAL_12129 | The ISRs shall be responsible for re-setting the interrupt flags and calling the according notification function | SWS_Spi_00999 |
| SRS_SPAL_12163 | All driver modules shall implement an interface for de-initialization | SWS_Spi_00021, SWS_Spi_00022 |
| SRS_SPAL_12265 | Configuration data shall be kept constant | SWS_Spi_00999 |
| SRS_SPAL_12267 | Wakeup sources shall be initialized by MCAL drivers and/or the MCU driver | SWS_Spi_00999 |
| SRS_Spi_12024 | The SPI Handler/Driver shall allow the static configuration of the following options | SWS_Spi_00008, SWS_Spi_00063 |
| SRS_Spi_12025 | The SPI Handler/Driver shall allow the static configuration of all software and hardware properties related to SPI | SWS_Spi_00008, SWS_Spi_00009, SWS_Spi_00052, SWS_Spi_00053, SWS_Spi_00063 |
| SRS_Spi_12026 | The SPI Handler/Driver shall allow the static configuration of the desired number of SPI channels | SWS_Spi_00009 |
| SRS_Spi_12032 | For an SPI channel assigned to an SPI HW Unit the chip select mode "normal" shall be available | SWS_Spi_00009, SWS_Spi_00066 |
| SRS_Spi_12033 | For an SPI channel assigned to an SPI HW Unit the chip select mode "hold" shall be available | SWS_Spi_00009, SWS_Spi_00066 |
| SRS_Spi_12037 | The SPI Handler/Driver shall allow a priority controlled allocation of the HW SPI unit | SWS_Spi_00014, SWS_Spi_00059, SWS_Spi_00124, SWS_Spi_00127 |
| SRS_Spi_12093 | The SPI Handler/Driver shall be able to handle multiple busses of communication | SWS_Spi_00009, SWS_Spi_00010, SWS_Spi_00034, SWS_Spi_00041, SWS_Spi_00135 |
| SRS_Spi_12094 | The SPI Handler/Driver shall handle the chip select | SWS_Spi_00009, SWS_Spi_00066 |
| SRS_Spi_12099 | The SPI Handler/Driver shall provide an asynchronous read functionality | SWS_Spi_00016, SWS_Spi_00020, SWS_Spi_00162, SWS_Spi_00163 |
| SRS_Spi_12101 | The SPI Handler/Driver shall provide an asynchronous write functionality | SWS_Spi_00018, SWS_Spi_00020, SWS_Spi_00162, SWS_Spi_00163 |
| SRS_Spi_12103 | The SPI Handler/Driver shall provide an asynchronous read-write functionality | SWS_Spi_00020, SWS_Spi_00053, SWS_Spi_00058, SWS_Spi_00067, SWS_Spi_00162, SWS_Spi_00163 |
| SRS_Spi_12104 | The SPI Handler/Driver shall provide a synchronous functionality which returns any transfer status | SWS_Spi_00025, SWS_Spi_00026, SWS_Spi_00324 |
| SRS_Spi_12108 | The SPI Handler/Driver shall call the statically configured notification function | SWS_Spi_00057, SWS_Spi_00118, SWS_Spi_00119, SWS_Spi_00120 |
| SRS_Spi_12150 | The SPI Handler/Driver shall allow the static configuration of all software and hardware properties related to asynchronous SPI aspects | SWS_Spi_00009, SWS_Spi_00064, SWS_Spi_00093 |
| SRS_Spi_12152 | The SPI Handler/Driver shall provide a | SWS_Spi_00016, SWS_Spi_00134 |

| | | |
|---------------|---|---|
| | synchronous read functionality | |
| SRS_Spi_12153 | The SPI Handler/Driver shall provide a synchronous write functionality | SWS_Spi_00018, SWS_Spi_00134 |
| SRS_Spi_12154 | The SPI Handler/Driver shall provide a synchronous write-read functionality | SWS_Spi_00134 |
| SRS_Spi_12170 | The SPI Handler/Driver shall not provide the ability to prevent a channel data overwrite | SWS_Spi_00042, SWS_Spi_00084 |
| SRS_Spi_12179 | The SPI Handler/Driver shall allow linking consecutive SPI channels by static configuration | SWS_Spi_00003, SWS_Spi_00009, SWS_Spi_00064, SWS_Spi_00065 |
| SRS_Spi_12180 | The SPI Driver shall access the SPI bus only for the channel | SWS_Spi_00003, SWS_Spi_00065 |
| SRS_Spi_12181 | If an SPI access request for a linked channel is performed, the SPI Handler/Driver shall use this SPI channel and all the linked channels | SWS_Spi_00055, SWS_Spi_00065 |
| SRS_Spi_12197 | The transmission data width of each SPI channel shall be configurable | SWS_Spi_00063 |
| SRS_Spi_12198 | The SPI Handler/Driver shall provide the functionality of transferring one short data sequence with variable data content | SWS_Spi_00053, SWS_Spi_00077 |
| SRS_Spi_12199 | The SPI Handler/Driver shall provide the functionality of transferring any data to any devices in one transfer sequence | SWS_Spi_00003, SWS_Spi_00064, SWS_Spi_00065 |
| SRS_Spi_12200 | Reading large data sequences from one slave device using dummy send data shall be possible | SWS_Spi_00003, SWS_Spi_00035, SWS_Spi_00053, SWS_Spi_00065, SWS_Spi_00077 |
| SRS_Spi_12201 | Reading large data sequences from multiple slave devices using dummy send data shall be possible | SWS_Spi_00003, SWS_Spi_00035, SWS_Spi_00065, SWS_Spi_00077 |
| SRS_Spi_12202 | The SPI Handler/Driver shall support data streams to a HW device with variable number of data | SWS_Spi_00053, SWS_Spi_00078 |
| SRS_Spi_12253 | The SPI Handler/Driver shall provide the functionality of transferring one short data sequence with constant data content | SWS_Spi_00052, SWS_Spi_00078 |
| SRS_Spi_12256 | The SPI Handler/Driver shall support all controller peripherals | SWS_Spi_00008, SWS_Spi_00009, SWS_Spi_00034 |
| SRS_Spi_12257 | The SPI Handler/Driver shall support the communication to daisy chained HW devices | SWS_Spi_00008, SWS_Spi_00009, SWS_Spi_00010, SWS_Spi_00034, SWS_Spi_00063, SWS_Spi_00065, SWS_Spi_00066 |
| SRS_Spi_12258 | Data shall be accessible from each device individually | SWS_Spi_00003, SWS_Spi_00009, SWS_Spi_00065 |
| SRS_Spi_12259 | Different timing and HW parameters shall be supported | SWS_Spi_00009 |

| | | |
|---------------|---|--|
| SRS_Spi_12260 | Different priorities of sequences shall be supported | SWS_Spi_00002, SWS_Spi_00009, SWS_Spi_00014, SWS_Spi_00059, SWS_Spi_00064, SWS_Spi_00093 |
| SRS_Spi_12261 | Reading large data sequences from one slave device using variable send data shall be possible | SWS_Spi_00003, SWS_Spi_00053, SWS_Spi_00065 |
| SRS_Spi_12262 | Reading large data sequences from multiple slave devices using variable send data shall be possible | SWS_Spi_00003, SWS_Spi_00053, SWS_Spi_00065, SWS_Spi_00078 |
| SRS_Spi_13400 | The SPI Handler/Driver shall have a scalable functionality to fit the needs of the ECU | SWS_Spi_00110 |
| SRS_Spi_13401 | The SPI Handler/Driver functionalities shall be statically configurable | SWS_Spi_00109, SWS_Spi_00111, SWS_Spi_00121, SWS_Spi_00122, SWS_Spi_00125 |

7 Functional specification

The SPI (Serial Peripheral Interface) has a 4-wire synchronous serial interface. Data communication is enabled with a Chip select wire (CS). Data is transmitted with a 3-wire interface consisting of wires for serial data output (MOSI), serial data input (MISO) and serial clock (CLOCK).

7.1 Overall view of functionalities and features

This specification is based on previous specification experiences and also based on predominant identified use cases. The intention of this section is to summarize how the scalability of this monolithic SPI Handler/Driver allows getting a simple software module that fits simple needs up to a smart software module that fits enhanced needs.

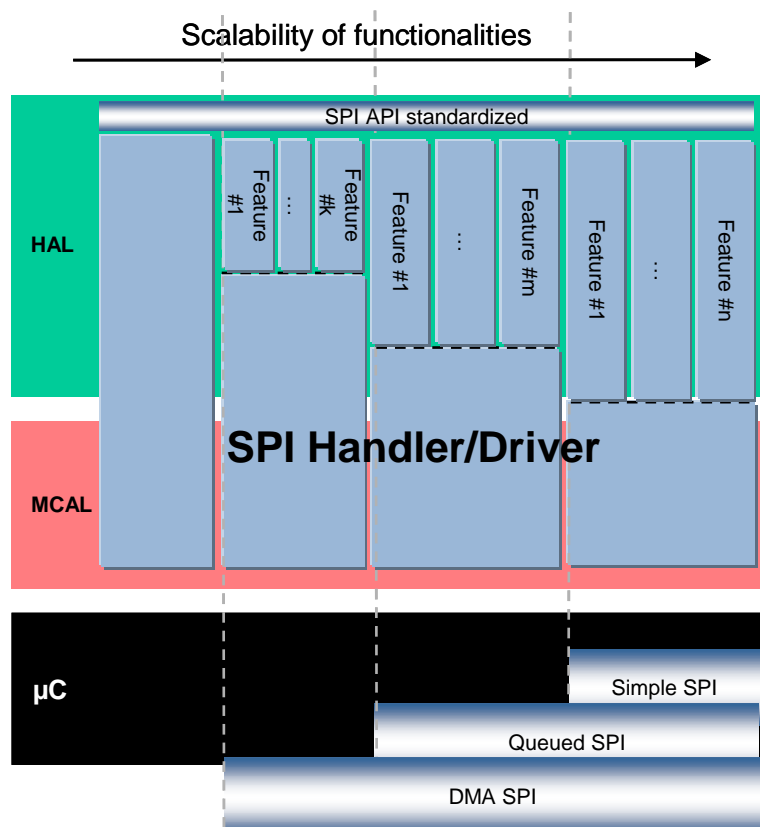

This document specifies the following 3 Levels of Scalable Functionality for the SPI Handler/Driver:

- LEVEL 0, **Simple Synchronous SPI Handler/Driver**: the communication is based on synchronous handling with a FIFO policy to handle multiple accesses. Buffer usage is configurable to optimize and/or to take advantage of HW capabilities.

- LEVEL 1, **Basic Asynchronous SPI Handler/Driver**: the communication is based on asynchronous behavior and with a Priority policy to handle multiple accesses. Buffer usage is configurable as for “Simple Synchronous” level.
- LEVEL 2, **Enhanced (Synchronous/Asynchronous) SPI Handler/Driver**: the communication is based on asynchronous behavior or synchronous handling, using either interrupts or polling mechanism selectable during execution time and with a Priority policy to handle multiple accesses. Buffer usage is configurable as for other levels.

[SWS_Spi_00109] [The SPI Handler/Driver’s level of scalable functionality shall always be statically configurable, i.e. configured at pre-compile time to allow the best source code optimisation.] (SRS_Spi_13401)

[SWS_Spi_00110] [The `SpiLevelDelivered` parameter shall be configured with one of the 3 authorized values according to the described levels (0, 1 or 2) to allow the selection of the SPI Handler/Driver’s level of scalable functionality.] (SRS_Spi_13400)

To improve the scalability, each level has optional features which are configurable (ON / OFF) or selectable. These are described in detail in the dedicated chapters.

7.2 General behaviour

This chapter, on the one hand, introduces common behavior and configuration for all levels. On the other, it specifies the behavior of each level and also the allowed optional features.

[SWS_Spi_00041] [The SPI Handler/Driver interface configuration shall be based on Channels, Jobs and Sequences as defined in this document (see chapter 2).] (SRS_Spi_12093)

[SWS_Spi_00034] [The SPI Handler/Driver shall support one or more Channels, Jobs and Sequences to drive all kind of SPI compatible HW devices.] (SRS_Spi_12093, SRS_Spi_12256, SRS_Spi_12257)

[SWS_Spi_00255] [Data transmissions shall be done according to Channels, Jobs and Sequences configuration parameters.] ()

[SWS_Spi_00066] [The Chip Select (CS) is attached to the Job definition.] (SRS_Spi_12094, SRS_Spi_12257, SRS_Spi_12032, SRS_Spi_12033)

[SWS_Spi_00263] [Chip Select shall be handled during Job transmission and shall be released at the end of it. This Chip Select handling shall be done according to the Job configuration parameters.] ()

[SWS_Spi_00370] [It shall be possible to define if the Chip Select handling is managed autonomously by the HW peripheral, without explicit chip select control by

the driver, or the SPI driver shall drive the chip select lines explicitly as DIO (see [ECUC_Spi_00212](#)).] ()

Example of CS handling: Set the CS active at the beginning of Job transmission; maintain it until the end of transmission of all Channels belonging to this Job afterwards set the CS inactive.

A Channel is defined one time but it could belong to several Jobs according to the user needs and this software specification.

[SWS_Spi_00065] [A Job shall contain at least one Channel.] (SRS_Spi_12257, SRS_Spi_12179, SRS_Spi_12258, SRS_Spi_12180, SRS_Spi_12181, SRS_Spi_12199, SRS_Spi_12200, SRS_Spi_12261, SRS_Spi_12201, SRS_Spi_12262)

[SWS_Spi_00368] [Each Channel shall have an associated index which is used for specifying the order of the Channel within the Job.] ()

[SWS_Spi_00262] [If a Job contains more than one Channel, all Channels contained have the same Job properties during transmission and shall be linked together statically.] ()

A Job is defined one time but it could belong to several Sequences according to the user needs and this software specification.

[SWS_Spi_00003] [A Sequence shall contain at least one Job.] (SRS_Spi_12179, SRS_Spi_12258, SRS_Spi_12180, SRS_Spi_12199, SRS_Spi_12200, SRS_Spi_12261, SRS_Spi_12201, SRS_Spi_12262)

[SWS_Spi_00236] [If it contains more than one, all Jobs contained have the same Sequence properties during transmission and shall be linked together statically.] ()

A Channel used for a transmission should have its parameters configured but it is allowed to pass Null pointers as source and destination pointers to generate a dummy transmission (See also [\[SWS_Spi_00028\]](#) & [\[SWS_Spi_00030\]](#)).

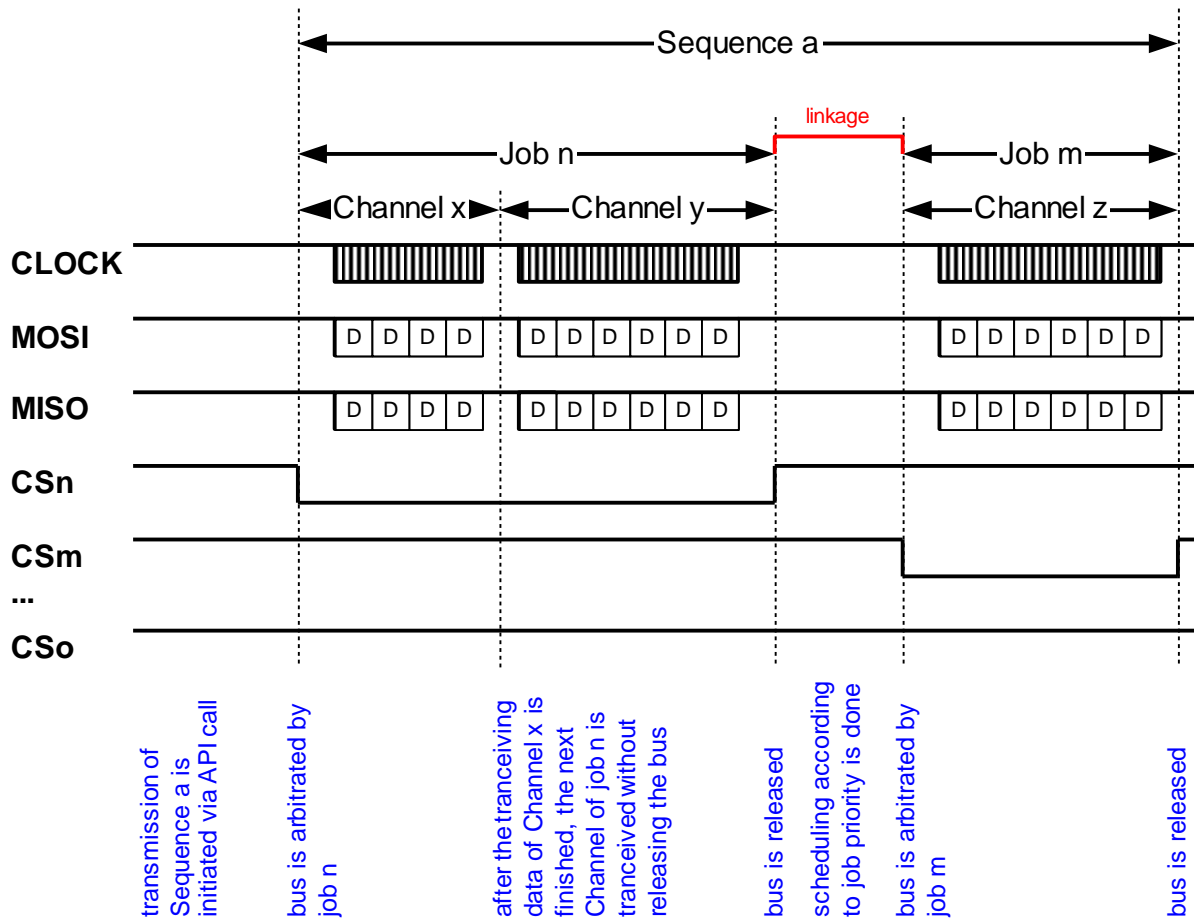

Channel data may differ from the hardware handled and user (client application) given. On the client side the data is handled in 8, 16 or 32bits mode base on SpiDataWidth (see chapter 8.2.5). On the microcontroller side, the hardware may handle between 1 and 32bits or may handle a fixed value (8 or 16bits) and this width is configurable for each Channel (see SpiDataWidth)..

[SWS_Spi_00149] [The SPI Handler/Driver shall take care of the differences between the frame width of channel (SpiDataWidth) and data access data type (given by SWS_Spi_00437).] ()

[SWS_Spi_00289] [If data width (SpiDataWidth) are exactly same (8 or 16 or 32 bits), the SPI Handler/Driver can send and receive data without any bit changes straightforward.] ()

[SWS_Spi_00290] [If data access casting type is superior to data width (for example SpiDataWidth = 12bits, data access is 16 bits), the data transmitted through the SPI Handler/Driver shall send the lower part, ignore the upper part. Receive the lower part, extend with zero.] ()

This ensures that the user always gets the same interface.

[SWS_Spi_00437] [Data buffers are accessed as uint8, uint16 or uint32 according to SpiDataWidth

independently to Spi_DataBufferType.

The data access will use following casting:

uint8 for SpiDataWidth < 9

uint16 for 9 ≤ SpiDataWidth < 17

uint32 for 17 ≤ SpiDataWidth] ()

7.2.1 Common configurable feature: Allowed Channel Buffers

In order to allow taking advantages of all microcontroller capabilities but also to allow sending/receiving of data to/from a dedicated memory location, all levels have an optional feature with respect to the location of Channel Buffers.

Hence, two main kinds of channel buffering can be used by configuration:

- Internally buffered Channels (IB): The buffer to transmit/receive data is provided by the Handler/Driver.
- Externally buffered Channels (EB): The buffer to transmit/receive is provided by the user (statically and/or dynamically).

Both channel buffering methods may be used depending on the 3 use cases described below:

- Usage 0: the SPI Handler/Driver manages only Internal Buffers.
- Usage 1: the SPI Handler/Driver manages only External Buffers.
- Usage 2: the SPI Handler/Driver manages both buffers types.

[SWS_Spi_00111] [The SpiChannelBuffersAllowed parameter shall be configured with one of the 3 authorized values (0, 1 or 2) according to the described usage.] (SRS_Spi_13401)

[SWS_Spi_00279] [The SpiChannelBuffersAllowed parameter shall be configured to select which Channel Buffers the SPI Handler/Driver manages.] ()

7.2.1.1 Behaviour of IB channels

The intention of Internal Buffer channels is to take advantage of microcontrollers including this feature by hardware. Otherwise, this feature should be simulated by software.

[SWS_Spi_00052] [For the IB Channels, the Handler/Driver shall provide the buffering but it is not able to take care of the consistency of the data in the buffer during transmission. The size of the Channel buffer is fixed.] (SRS_Spi_12025, SRS_Spi_12253)

[SWS_Spi_00049] [The channel data received shall be stored in 1 entry deep internal buffers by channel. The SPI Handler/Driver shall not take care of the overwriting of these “receive” buffers by another transmission on the same channel.] ()

[SWS_Spi_00051] [The channel data to be transmitted shall be copied in 1 entry deep internal buffers by channel.] ()

[SWS_Spi_00257] [The SPI Handler/Driver is not able to prevent the overwriting of these “transmit” buffers by users during transmissions.] ()

[SWS_Spi_00438] [The Handler/Driver shall provide separate buffer for receive and transmit to ensure that transmitted data are not overwritten by the receive data.] ()

7.2.1.2 Behaviour of EB channels

The intention of External Buffer channels is to reuse existing buffers that are located outside. That means the SPI Handler/Driver does not monitor them.

[SWS_Spi_00053] [For EB Channels the application shall provide the buffering and shall take care of the consistency of the data in the buffer during transmission.] (SRS_SPAL_12075, SRS_Spi_12025, SRS_Spi_12198, SRS_Spi_12200, SRS_Spi_12261, SRS_Spi_12262, SRS_Spi_12202, SRS_Spi_12103)

[SWS_Spi_00112] [The size of the Channel buffer is either fixed or variable. A maximum size for the Channel buffer shall be defined by the configuration.] ()

[SWS_Spi_00280] [The buffer provided by the application for the SPI Handler Driver may have a different size.] ()

7.2.1.3 Buffering channel usage

The following table provides information about the Channel characteristics:

| <i>IB Channels</i> | |
|---------------------------|---|
| It provides... | <ul style="list-style-type: none"> • A more abstracted concept (buffering mechanisms are hidden) • Actual and future optimal implementation taken profit of HW buffer facilities (Given size of 256 bytes covers nowadays requirements). |
| Suggested use ... | <ul style="list-style-type: none"> • Daisy-chain implementation. • Small data transfer devices (up to 10 Bytes). |
| <i>EB Channels</i> | |
| It provides... | <ul style="list-style-type: none"> • Efficient mechanism to support large stream communication. • Send constant data out of ROM tables and spare RAM size. • Send various data tables each for a different device (highly complex ASICs with several integrated peripheral devices, also mixed signal types, could exceed IB HW buffer size) |
| Suggested use ... | <ul style="list-style-type: none"> • Large streams communication. • EEPROM communication. • Control of complex HW Chips . |

7.2.2 LEVEL 0, Simple Synchronous behaviour

The intention of this functionality level is to provide a Handler/Driver with a reduced set of services to handle only simple synchronous transmissions. This is often the case for ECU including simple SPI networks but also for ECU using high speed external devices.

A simple synchronous transmission means that the function calling the transmission service is blocked during the ongoing transmission until the transmission is finished.

[SWS_Spi_00160] [The LEVEL 0 SPI Handler/Driver shall offer a synchronous transfer service for SPI busses.] ()

[SWS_Spi_00161] [For an SPI Handler/Driver operating in LEVEL 0, when there is no on going Sequence transmission, the SPI Handler/Driver shall be in the idle state SPI_IDLE.] ()

[SWS_Spi_00294] [This monolithic SPI Handler/Driver is able to handle one to n SPI buses according to the microcontroller used.] ()

Then SPI buses are assigned to Jobs and not to Sequences. Consequently, Jobs, on different SPI buses, could belong to the same Sequence. Therefore:

[SWS_Spi_00114] [The LEVEL 0 SPI Handler/Driver shall accept concurrent Spi_SyncTransmit(), if the sequences to be transmitted use different bus and parameter SPI_SUPPORT_CONCURRENT_SYNC_TRANSMIT is enabled. This feature shall be disabled per default. That means during a Sequence on-going transmission, all requests to transmit another Sequence shall be rejected.] ()

[SWS_Spi_00115] [The LEVEL 0 SPI Handler/Driver behaviour shall include the common feature: Allowed Channel Buffers, which is selected.] ()

[SWS_Spi_00084] [If different Jobs (and consequently also Sequences) have common Channels, the SPI Handler/Driver' environment shall ensure that read and/or write functions are not called during transmission.] (SRS_Spi_12170)

[SWS_Spi_00384][When a hardware error is detected, the SPI Handler/Driver shall stop the current sequence, report an error to the DEM as configured and set the state of the Job to SPI_JOB_FAILED and the state of the Sequence to SPI_SEQ_FAILED.] ()

Read and write functions can not guarantee the data integrity while Channel data is being transmitted.

7.2.3 LEVEL 1, Basic Asynchronous behavior

The intention of this functionality level is to provide a Handler/Driver with a reduced set of services to handle asynchronous transmissions only. This is often the case for

ECU with functions related to SPI networks having different priorities but also for ECU using low speed external devices.

An asynchronous transmission means that the user calling the transmission service is not blocked when the transmission is on-going. Furthermore, the user can be notified at the end of transmission¹.

[SWS_Spi_00162] [The LEVEL 1 SPI Handler/Driver shall offer an asynchronous transfer service for SPI buses. An asynchronous transmission means that the user calling the transmission service is not blocked when the transmission is on going.] (SRS_Spi_12099, SRS_Spi_12101, SRS_Spi_12103)

[SWS_Spi_00295] [The LEVEL 1 SPI Handler/Driver shall offer an asynchronous transfer service for SPI buses. Furthermore, the user can be notified at the end of transmission.] ()

[SWS_Spi_00163] [For an SPI Handler/Driver operating in LEVEL 1, when there is no on-going Sequence transmission, the SPI Handler/Driver shall be in the idle state (SPI_IDLE).] (SRS_Spi_12099, SRS_Spi_12101, SRS_Spi_12103)

This Handler/Driver will be used by several software modules which may be independent from each other and also may belong to different layers. Therefore, priorities will be assigned to Jobs in order to figure out specific cases of multiple accesses. These cases usually occur within real time systems based on asynchronous mechanisms.

[SWS_Spi_00002] [Jobs have priorities assigned. Jobs linked in a Sequence shall have same or de-creasing priorities. That means the first Job shall have the equal priority or the highest priority of all Jobs within the Sequence.] (SRS_Spi_12260)

[SWS_Spi_00093] [Priority order of jobs shall be from the lower to the higher value defined, higher value higher priority (from 0, the lower to 3, the higher, limited to 4 priority levels see [\[SWS_Spi_00009\]](#)).] (SRS_Spi_12260, SRS_Spi_12150)

With reference to Jobs priorities, this Handler/Driver needs rules to make a decision in these specific cases of multiple accesses.

[SWS_Spi_00059] [The SPI Handler/Driver scheduling method shall schedule Jobs in order to send the highest priority Job first.] (SRS_Spi_12260, SRS_Spi_12037)

This monolithic SPI Handler/Driver is able to handle one to n SPI busses according to the microcontroller used. But SPI busses are assigned to Jobs and not to Sequences. Consequently, Jobs on different SPI busses could belong to the same Sequence. Therefore:

¹ This basic asynchronous behaviour might be implemented either by using interrupt or by polling mechanism. This software design choice is not in the scope of this document, but only solution is required for the LEVEL 1.

[SWS_Spi_00116] [The LEVEL 1 SPI Handler/Driver may allow transmitting more than one Sequence at the same time. That means during a Sequence transmission, all requests to transmit another Sequence shall be evaluated in order to accept to start a new sequence or to reject it accordingly to the lead Job.] ()

[SWS_Spi_00117] [The LEVEL 1 SPI Handler/Driver behaviour shall include the common feature: Allowed Channel Buffers, which is selected, and the configured asynchronous feature: Interruptible Sequence (see next chapter).] ()

[SWS_Spi_00267] [When a hardware error is detected, the SPI Handler/Driver shall stop the current Sequence, report an error to the DEM as configured and set the state of the Job to SPI_JOB_FAILED and the state of the Sequence to SPI_SEQ_FAILED.] ()

[SWS_Spi_00118] [If Jobs are configured with a specific end notification function, the SPI Handler/Driver shall call this notification function at the end of the Job transmission.] (SRS_Spi_12108)

[SWS_Spi_00281] [If Sequences are configured with a specific end notification function, the SPI Handler/Driver shall call this notification function at the end of the Sequence transmission.] ()

[SWS_Spi_00119] [When a valid notification function pointer is configured (see [\[SWS_Spi_00071\]](#)), the SPI Handler/Driver shall call this notification function at the end of a Job transmission regardless of the result of the Job transmission being either SPI_JOB_FAILED or SPI_JOB_OK (rational: avoid deadlocks or endless loops).] (SRS_Spi_12108)

[SWS_Spi_00120] [When a valid notification function pointer is configured (see [\[SWS_Spi_00073\]](#)), the SPI Handler/Driver shall call this notification function at the end of a Sequence transmission regardless of the result of the Sequence transmission being either SPI_SEQ_FAILED, SPI_SEQ_OK or SPI_SEQ_CANCELLED (rational: avoid deadlocks or endless loops).] (SRS_Spi_12108)

7.2.4 Asynchronous configurable feature: Interruptible Sequences

In order to allow taking advantages of asynchronous transmission mechanism, level 1 and level 2 of this SPI Handler/Driver have an optional feature with respect to suspending the transmission of Sequences.

Hence two main kinds of sequences can be used by configuration:

- Non-Interruptible Sequences, every Sequence transmission started is not suspended by the Handler/Driver until the end of transmission.
- Mixed Sequences, according to its configuration, a Sequence transmission started may be suspended by the Handler/Driver between two of their consecutive Jobs.

[SWS_Spi_00121] [The SPI Handler/Driver's environment shall configure the `SpiInterruptibleSeqAllowed` parameter (ON / OFF) in order to select which kind of Sequences the SPI Handler/Driver manages.] (SRS_Spi_13401)

7.2.4.1 Behavior of Non-Interruptible Sequences

The intention of the Non-Interruptible Sequences feature is to provide a simple software module based on a basic asynchronous mechanism, if only non blocking transmissions should be used.

[SWS_Spi_00122] [Interruptible Sequences are not allowed within levels 1 and 2 of the SPI/Handler/Driver when the `SpiInterruptibleSeqAllowed` parameter is switched off (i.e. configured with value "OFF").] (SRS_Spi_13401)

[SWS_Spi_00123] [When the SPI Handler/Driver is configured not allowing interruptible Sequences, all Sequences declared are considered as Non-Interruptible Sequences².] ()

[SWS_Spi_00282] [When the SPI Handler/Driver is configured not allowing interruptible Sequences their dedicated parameter `SpiInterruptibleSequence` can be omitted or the FALSE value should be used as default.] ()

[SWS_Spi_00124] [According to [\[SWS_Spi_00116\]](#) and [\[SWS_Spi_00122\]](#) requirements, the SPI Handler/Driver is not allowed to suspend a Sequence transmission already started in favour of another Sequence.] (SRS_Spi_12037)

7.2.4.2 Behavior of Mixed Sequences

The intention of the Mixed Sequences feature is to provide a software module with specific asynchronous mechanisms, if, for instance, very long Sequences that could or should be suspended by others with higher priority are used.

[SWS_Spi_00125] [Interruptible Sequences are allowed within levels 1 and 2 of SPI Handler/Driver when the `SpiInterruptibleSeqAllowed` parameter is switched on (i.e. configured with value "ON").] (SRS_Spi_13401)

[SWS_Spi_00126] [**When** the SPI Handler/Driver is configured allowing interruptible Sequences, all Sequences declared shall have their dedicated parameter `SpiInterruptibleSequence` (see [SWS_Spi_00064](#) & [SPI106](#)) to identify whether the Sequence can be suspended during transmission.] ()

² The intention of this requirement is not to enforce any implementation solution in comparison with another one. But, it is only to ensure that anyhow, all Sequences will be considered as Non Interruptible Sequences.

[SWS_Spi_00014] [In case of a Sequence configured as Interruptible Sequence and according to [\[SWS_Spi_00125\]](#) requirement, the SPI Handler/Driver is allowed to suspend an already started Sequence transmission in favour of another Sequence with a higher priority Job (see [SWS_Spi_00002](#) & [SWS_Spi_00093](#)). That means, at the end of a Job transmission (that belongs to the interruptible sequence) with another Sequence transmit request pending, the SPI Handler/Driver shall perform a re-scheduling in order to elect the next Job to transmit.] (SRS_Spi_12260, SRS_Spi_12037)

[SWS_Spi_00127] [In case of a Sequence configured as Non-Interruptible Sequence and according to requirement [\[SWS_Spi_00125\]](#), the SPI Handler/Driver is not allowed to suspend this already started Sequence transmission in favour of another Sequence.] (SRS_Spi_12037)

[SWS_Spi_00080] [When using Interruptible Sequences, the caller must be aware that if the multiple Sequences access the same Channels, the data for these Channels may be overwritten by the highest priority Job accessing each Channel.] ()

7.2.5 LEVEL 2, Enhanced behaviour

The intention of this functionality level is to provide a Handler/Driver with a complete set of services to handle synchronous and asynchronous transmissions. This could be the case for ECU with a lot of functions related to SPI networks having different priorities but also for ECU using external devices with different speeds.

Handling asynchronous and synchronous transmissions means that the microcontroller for which this software module is dedicated has to provide more than one SPI bus (see [\[SWS_Spi_00108\]](#)). In fact, the goal is to support SPI buses using a so-called synchronous driver and to support other SPI buses using a so-called asynchronous driver.

[SWS_Spi_00128] [The LEVEL 2 SPI Handler/Driver shall offer a synchronous transfer service for all SPI HW units configured as synchronous and it shall also offer an asynchronous transfer service for all other SPI buses.] ()

[SWS_Spi_00283] [In LEVEL 2 if there is no on going Sequence transmission, the SPI Handler/Driver shall be in idle state (SPI_IDLE).] ()

Usually, depending on software design, asynchronous end transmission may be detected by polling or interrupt mechanisms. This level of functionality proposes both mechanisms that are selectable during execution time.

[SWS_Spi_00155] [The SPI Handler/Driver LEVEL 2 shall implement one polling mechanism mode and one interrupt mechanism mode for SPI buses handled asynchronously.] ()

[SWS_Spi_00156] [Both the polling mechanism and interrupt mechanism modes for SPI busses shall be selectable during execution time (see [\[SWS_Spi_00188\]](#)).] ()

The requirements for LEVEL 0 apply to synchronous behaviour.
The requirements for LEVEL 1 apply to asynchronous behaviour.

7.3 Scheduling Advices

For asynchronous levels, LEVEL 1 and LEVEL 2, the SPI Handler/Driver can call end notification functions at the end of a Job and/or Sequence transmission (see [\[SWS_Spi_00118\]](#)). In a second time, in case of interruptible Sequences (that could be suspended), if another Sequence transmit request is pending, a rescheduling is also done by the SPI Handler/Driver in order to elect the next Job to transmit (see [\[SWS_Spi_00014\]](#)).

[SWS_Spi_00088] [For asynchronous levels, LEVEL 1 and LEVEL 2, the SPI Handler/Driver can call end notification functions at the end of a Job.] ()

[SWS_Spi_00268] [For asynchronous levels, LEVEL 1 and LEVEL 2, the SPI Handler/Driver can call end notification functions at the end of a Sequence transmission.] ()

[SWS_Spi_00269] [For asynchronous levels, LEVEL 1 and LEVEL 2 in case of interruptible Sequences, if another Sequence transmit request is pending, a rescheduling is also done by the SPI Handler/Driver in order to elect the next Job to transmit.] ()

[SWS_Spi_00270] [In case call end notification function and rescheduling are fully done by software, the order between these shall be first scheduling and then the call of end notification function executed.] ()

[SWS_Spi_00271] [In case call end notification function and rescheduling are fully done by hardware, the order could not be configured as required; the order shall be completely documented.] ()

7.4 Error classification

[SWS_Spi_00004] [SPI Handler/driver shall be able to detect the error SPI_E_PARAM_CHANNEL when API service called with wrong parameter.] (SRS_BSW_00327, SRS_BSW_00337, SRS_BSW_00385)

[SWS_Spi_00237] [SPI Handler/driver shall be able to detect the error SPI_E_PARAM_JOB when API service called with wrong parameter.] ()

[SWS_Spi_00238] [SPI Handler/driver shall be able to detect the error SPI_E_PARAM_SEQ when API service called with wrong parameter.] ()

[SWS_Spi_00240] [SPI Handler/driver shall be able to detect the error SPI_E_PARAM_LENGTH when API service called with wrong parameter.] ()

[SWS_Spi_00241] [SPI Handler/driver shall be able to detect the error SPI_E_PARAM_UNIT when API service called with wrong parameter.] ()

[SWS_Spi_00242] [SPI Handler/driver shall be able to detect the error SPI_E_UNINIT when API service used without module initialization.] ()

[SWS_Spi_00243] [SPI Handler/driver shall be able to detect the error SPI_E_SEQ_PENDING when services called in a wrong sequence.] ()

[SWS_Spi_00245] [SPI Handler/driver shall be able to detect the error SPI_E_SEQ_IN_PROCESS when synchronous transmission service called at wrong time.] ()

[SWS_Spi_00246] [SPI Handler/driver shall be able to detect the error SPI_E_ALREADY_INITIALIZED when API SPI_Init service called while the SPI driver has already been initialized time.] ()

[SWS_Spi_00195] [SPI Handler/driver shall be able to detect the error SPI_E_HARDWARE_ERROR when an hardware error occur during asynchronous or synchronous transmit. Please see also SWS_Spi_00267 and SWS_Spi_00384.] ()

The Sections 7.4.1, 7.4.2 and 7.4.5 summarize the errors that the SPI Handler/Driver shall be able to detect.

7.4.1 Development Errors

| <i>Type or error</i> | <i>Related error code</i> | <i>Value[hex]</i> |
|---|---|--------------------------------------|
| API service called with wrong parameter | SPI_E_PARAM_CHANNEL SPI_E_PARAM_JOB SPI_E_PARAM_SEQ SPI_E_PARAM_LENGTH SPI_E_PARAM_UNIT | 0x0A 0x0B 0x0C 0x0D 0x0E |
| APIs called with a Null Pointer | SPI_E_PARAM_POINTER | 0x10 |
| API service used without module initialization | SPI_E_UNINIT | 0x1A |
| API SPI_Init service called while the SPI driver has already been initialized | SPI_E_ALREADY_INITIALIZED | 0x4A |

7.4.2 Runtime Errors

| <i>Type or error</i> | <i>Related error code</i> | <i>Value[hex]</i> |
|-------------------------------------|---------------------------|-------------------|
| Services called in a wrong sequence | SPI_E_SEQ_PENDING | 0x2A |
| Synchronous transmission service | SPI_E_SEQ_IN_PROCESS | 0x3A |

| | | |
|----------------------|--|--|
| called at wrong time | | |
|----------------------|--|--|

7.4.3 Transient faults

There are no transient faults.

7.4.4 Production Errors

There are no production errors.

7.4.5 Extended Production Errors

[SWS_Spi_00383]

| | | |
|------------------------------|--|--|
| Error Name: | SPI_E_HARDWARE_ERROR | |
| Short Description: | An hardware error occurred during asynchronous or synchronous SPI transmit | |
| Long Description: | This Extended Production Error shall be issued when any error bit inside the SPI hardware transmit status register is raised | |
| Detection Criteria: | Fail | The SPI transmit status register information shall be reported to DEM as Dem_SetEventStatus (SPI_E_HARDWARE_ERROR, DEM_EVENT_STATUS_FAILED) when any error bit inside the SPI transmit status register is set. (SWS_Spi_00385) |
| | Pass | The SPI transmit status register information shall be reported to DEM as Dem_SetEventStatus (SPI_E_HARDWARE_ERROR, DEM_EVENT_STATUS_PASSED) when no error bit inside the SPI transmit status register is set. (SWS_Spi_00386) |
| Secondary Parameters: | N/A | |
| Time Required: | N/A | |
| Monitor Frequency | continuous | |

] ()

[SWS_Spi_00385] When any error bit inside the SPI transmit status register is set, the SPI transmit status register information shall be reported to DEM as Dem_SetEventStatus (SPI_E_HARDWARE_ERROR, DEM_EVENT_STATUS_FAILED)] ()

[SWS_Spi_00386] When no error bit inside the SPI transmit status register is set, the SPI transmit status register information shall be reported to DEM as Dem_SetEventStatus (SPI_E_HARDWARE_ERROR, DEM_EVENT_STATUS_PASSED)] ()

7.5 Error detection

7.5.1 API parameter checking

[SWS_Spi_00031] [The API parameter `Channel` shall have a value within the defined channels in the initialization data structure, and the correct type of channel (IB or EB) has to be used with services. Related error value: `SPI_E_PARAM_CHANNEL`. Otherwise, the service is not done and the return value shall be `E_NOT_OK`.] (SRS_BSW_00323)

[SWS_Spi_00032] [The API parameters `Sequence` and `Job` shall have values within the specified range of values. Related errors values: `SPI_E_PARAM_SEQ` or `SPI_E_PARAM_JOB`.] (SRS_BSW_00323)

[SWS_Spi_00254] [If the `Sequence` and `Job` related service is not done and, depending on services, either the return value shall be `E_NOT_OK` or a failed result (`SPI_JOB_FAILED` or `SPI_SEQ_FAILED`).] ()

[SWS_Spi_00060] [The API parameter `Length` of data shall have a value within the specified buffer maximum value. Related error value: `SPI_E_PARAM_LENGTH`.] (SRS_BSW_00323)

[SWS_Spi_00258] [If the API parameter `Length` related service is not done and the return value shall be `E_NOT_OK`.] ()

[SWS_Spi_00143] [The API parameter `HWUnit` shall have a value within the specified range of values. Related error value: `SPI_E_PARAM_UNIT`.] ()

[SWS_Spi_00288] [If `HWUnit` related service is not done and the return value shall be `SPI_UNINIT`.] ()

[SWS_Spi_00235] [If not applicable, the SPI Handler/Driver module's environment shall pass a `NULL` pointer to the function `Spi_Init`.] ()

7.5.2 SPI state checking

[SWS_Spi_00046] [If development error detection for the SPI module is enabled and the SPI Handler/Driver's environment calls any API function before initialization, an error should be reported to the DET with the error value `SPI_E_UNINIT` according to the configuration.] (SRS_BSW_00406)

[SWS_Spi_00256] [The SPI Handler/Driver shall not process the invoked function but, depending on the invoked function, shall either return the value `E_NOT_OK` or a failed result (`SPI_JOB_FAILED` or `SPI_SEQ_FAILED`).] ()

[SWS_Spi_00233] [

If development error detection for the SPI module is enabled, the calling of the routine `SPI_Init()` while the SPI driver is already initialized will cause a development error `SPI_E_ALREADY_INITIALIZED` and the desired functionality shall be left without any action.] ()

8 API specification

8.1 Imported types

In this chapter all types included from the following files are listed:

[SWS_Spi_00174] [Dem_EventIdType shall be imported from Dem_Types.h.] (SRS_BSW_00357)

| Module | Imported Type |
|-----------|---------------------|
| Dem | Dem_EventIdType |
| | Dem_EventStatusType |
| Std_Types | Std_ReturnType |
| | Std_VersionInfoType |

8.2 Type definitions

8.2.1 Spi_ConfigType

[SWS_Spi_00372] [

| | | |
|---------------------|--|---|
| Name: | Spi_ConfigType | |
| Type: | Structure | |
| Range: | Implementation Specific | The contents of the initialization data structure are SPI specific. |
| Description: | This type of the external data structure shall contain the initialization data for the SPI Handler/Driver. | |

] ()

[SWS_Spi_00344] [The description of the type Spi_ConfigType is implementation specific and it shall be provided for external use.] ()

[SWS_Spi_00008] [The type Spi_ConfigType is an external data structure and shall contain the initialization data for the SPI Handler/Driver. It shall contain:

- MCU dependent properties for SPI HW units
- Definition of Channels
- Definition of Jobs
- Definition of Sequences] (SRS_BSW_00405, SRS_SPAL_12125, SRS_Spi_12256, SRS_Spi_12257, SRS_Spi_12025, SRS_Spi_12024)

[SWS_Spi_00063] [For the type Spi_ConfigType, the definition for each Channel shall contain:

- Buffer usage with EB/IB Channel
- Transmit data width (1 up to 32 bits)
- Number of data buffers for IB Channels (at least 1) or it is the maximum of data for EB Channels (a value of 0 makes no sense)
- Transfer start LSB or MSB
- Default transmit value] (SRS_Spi_12257, SRS_Spi_12025, SRS_Spi_12197, SRS_Spi_12024)

[SWS_Spi_00009] [For the type `Spi_ConfigType`, the definition for each Job shall contain:

- Assigned SPI HW Unit
- Assigned Chip Select pin (it is possible to assign no pin)
- Chip select functionality on/off
- Chip select pin polarity high or low
- Baud rate
- Timing between clock and chip select
- Shift clock idle low or idle high
- Data shift with leading or trailing edge
- Priority (4 levels are available from 0, the lower to 3, the higher)
- Job finish end notification function
- MCU dependent properties for the Job (only if needed)
- Fixed link of Channels (at least one)] (SRS_BSW_00344, SRS_SPAL_12056, SRS_SPAL_12125, SRS_Spi_12093, SRS_Spi_12094, SRS_Spi_12256, SRS_Spi_12257, SRS_Spi_12025, SRS_Spi_12179, SRS_Spi_12026, SRS_Spi_12259, SRS_Spi_12258, SRS_Spi_12260, SRS_Spi_12032, SRS_Spi_12033, SRS_Spi_12150)

[SWS_Spi_00064] [For the type `Spi_ConfigType`, the definition for each Sequence shall contain:

- Collection of Jobs (at least one)
- Interruptible or not interruptible after each Job
- Sequence finish end notification function] (SRS_SPAL_12056, SRS_Spi_12179, SRS_Spi_12260, SRS_Spi_12199, SRS_Spi_12150)

[SWS_Spi_00010] [For the type `Spi_ConfigType`, the configuration will map the Jobs to the different SPI hardware units and the devices.] (SRS_Spi_12093, SRS_Spi_12257)

8.2.2 Spi_StatusType

[SWS_Spi_00373] [

| | | | |
|---------------------|--|------|---|
| Name: | Spi_StatusType | | |
| Type: | Enumeration | | |
| Range: | SPI_UNINIT | 0x00 | The SPI Handler/Driver is not initialized or not usable. |
| | SPI_IDLE | 0x01 | The SPI Handler/Driver is not currently transmitting any Job. |
| | SPI_BUSY | 0x02 | The SPI Handler/Driver is performing a SPI Job (transmit). |
| Description: | This type defines a range of specific status for SPI Handler/Driver. | | |

] (SRS_BSW_00406, SRS_BSW_00335)

[SWS_Spi_00061] [The type `Spi_StatusType` defines a range of specific status for SPI Handler/Driver. It informs about the SPI Handler/Driver status or specified SPI Hardware microcontroller peripheral.] (SRS_BSW_00335)

[SWS_Spi_00259] [The type `Spi_StatusType` can be obtained calling the API service `Spi_GetStatus.`] ()

[SWS_Spi_00260] [The type Spi_StatusType can be obtained calling the API service Spi_GetHWUnitStatus.] ()

[SWS_Spi_00011] [After reset, the type Spi_StatusType shall have the default value SPI_UNINIT.] ()

[SWS_Spi_00345] [API service Spi_GetStatus shall return SPI_UNINIT when the SPI Handler/Driver is not initialized or not usable.] ()

[SWS_Spi_00346] [API service Spi_GetStatus shall return SPI_IDLE when The SPI Handler/Driver is not currently transmitting any Job.] ()

[SWS_Spi_00347] [API service Spi_GetStatus shall return SPI_BUSY when The SPI Handler/Driver is performing a SPI Job transmit.] ()

[SWS_Spi_00348] [Spi_GetHWUnitStatus function shall return SPI_IDLE when The SPI Hardware microcontroller peripheral is not currently transmitting any Job,] ()

[SWS_Spi_00349] [Spi_GetHWUnitStatus function shall return SPI_BUSYwhen The SPI Hardware microcontroller peripheral is performing a SPI Job transmit.] ()

8.2.3 Spi_JobResultType

[SWS_Spi_00374] [

| | | |
|---------------------|---|---|
| Name: | Spi_JobResultType | |
| Type: | Enumeration | |
| Range: | SPI_JOB_OK | --The last transmission of the Job has been finished successfully. |
| | SPI_JOB_PENDING | --The SPI Handler/Driver is performing a SPI Job. The meaning of this status is equal to SPI_BUSY. |
| | SPI_JOB_FAILED | --The last transmission of the Job has failed. |
| | SPI_JOB_QUEUED | --An asynchronous transmit Job has been accepted, while actual transmission for this Job has not started yet. |
| Description: | This type defines a range of specific Jobs status for SPI Handler/Driver. | |

] ()

[SWS_Spi_00062] [The type Spi_JobResultType defines a range of specific Jobs status for SPI Handler/Driver.] (SRS_BSW_00335)

[SWS_Spi_00261] [The type Spi_JobResultType it informs about a SPI Handler/Driver Job status and can be obtained calling the API service Spi_GetJobResult with the Job ID.] ()

[SWS_Spi_00012] [After reset, the type Spi_JobResultType shall have the default value SPI_JOB_OK.] ()

[SWS_Spi_00350] [The function Spi_GetJobResult shall return SPI_JOB_OK when the last transmission of the Job has been finished successfully.] ()

8.2.4 Spi_SeqResultType

[SWS_Spi_00375] [

| | | |
|---------------------|--|---|
| Name: | Spi_SeqResultType | |
| Type: | Enumeration | |
| Range: | SPI_SEQ_OK | --The last transmission of the Sequence has been finished successfully. |
| | SPI_SEQ_PENDING | --The SPI Handler/Driver is performing a SPI Sequence. The meaning of this status is equal to SPI_BUSY. |
| | SPI_SEQ_FAILED | --The last transmission of the Sequence has failed. |
| | SPI_SEQ_CANCELED | --The last transmission of the Sequence has been canceled by user. |
| Description: | This type defines a range of specific Sequences status for SPI Handler/Driver. | |

] ()

[SWS_Spi_00351] [The type Spi_SeqResultType defines a range of specific Sequences status for SPI Handler/Driver and can be obtained calling the API service Spi_GetSequenceResult, it shall be provided for external use.] ()

[SWS_Spi_00019] [The type Spi_SeqResultType defines the range of specific Sequences status for SPI Handler/Driver.] (SRS_BSW_00335)

[SWS_Spi_00251] [The type Spi_SeqResultType defines about SPI Handler/Driver Sequence status and can be obtained calling the API service Spi_GetSequenceResult with the Sequence ID.] ()

[SWS_Spi_00017] [After reset, the type Spi_SeqResultType shall have the default value SPI_SEQ_OK.] ()

[SWS_Spi_00352] [Spi_GetSequenceResult function shall return SPI_SEQ_OK when the last transmission of the Sequence has been finished successfully.] ()

[SWS_Spi_00353] [Spi_GetSequenceResult function shall return SPI_SEQ_PENDING when the SPI Handler/Driver is performing a SPI Sequence. The meaning of this status is equal to SPI_BUSY.] ()

[SWS_Spi_00354] [Spi_GetSequenceResult function shall return SPI_SEQ_FAILED when the last transmission of the Sequence has failed.] ()

8.2.5 Spi_DataBufferType

[SWS_Spi_00376] [

| | |
|---------------------|---|
| Name: | Spi_DataBufferType |
| Type: | uint8 |
| Description: | Type of application data buffer elements. |

] ()

[SWS_Spi_00355] [Spi_DataBufferType defines the type of application data buffer elements. Type is uint8. Access to the data is selected dynamically as is described in [SWS_SPI_00437](#). The data buffer has to be aligned to 32 bits. It shall be provided for external use.] ()

[SWS_Spi_00164] [The type `Spi_DataBufferType` refers to application data buffer elements.] ()

8.2.6 Spi_NumberOfDataType

[SWS_Spi_00377] [

| | |
|---------------------|---|
| Name: | <code>Spi_NumberOfDataType</code> |
| Type: | <code>uint16</code> |
| Description: | Type for defining the number of data elements of the type <code>Spi_DataBufferType</code> to send and / or receive by Channel |

] ()

[SWS_Spi_00165] [The type `Spi_NumberOfDataType` is used for defining the number of data elements of the type specified in [\[SWS_SPI_00437\]](#) to send and / or receive by Channel.] ()

8.2.7 Spi_ChannelType

[SWS_Spi_00378] [

| | |
|---------------------|--|
| Name: | <code>Spi_ChannelType</code> |
| Type: | <code>uint8</code> |
| Description: | Specifies the identification (ID) for a Channel. |

] ()

[SWS_Spi_00356] [The type `Spi_ChannelType` specifies the identification (ID) for a Channel.] ()

[SWS_Spi_00166] [The type `Spi_ChannelType` is used for specifying the identification (ID) for a Channel.] ()

8.2.8 Spi_JobType

[SWS_Spi_00379] [

| | |
|---------------------|--|
| Name: | <code>Spi_JobType</code> |
| Type: | <code>uint16</code> |
| Description: | Specifies the identification (ID) for a Job. |

] ()

[SWS_Spi_00357] [The type `Spi_JobType` specifies the identification (ID) for a Job.] ()

[SWS_Spi_00167] [The type `Spi_JobType` is used for specifying the identification (ID) for a Job.] ()

8.2.9 Spi_SequenceType

[SWS_Spi_00380] [

| | |
|---------------------|---|
| Name: | <code>Spi_SequenceType</code> |
| Type: | <code>uint8</code> |
| Description: | Specifies the identification (ID) for a sequence of jobs. |

] ()

[SWS_Spi_00358] [The type Spi_SequenceType specifies the identification (ID) for a sequence of jobs.] ()

[SWS_Spi_00168] [The type Spi_SequenceType is used for specifying the identification (ID) for a sequence of jobs.] ()

8.2.10 Spi_HWUnitType

[SWS_Spi_00381] [

| | | |
|---------------------|---|--|
| Name: | Spi_HWUnitType | |
| Type: | uint8 | |
| Description: | Specifies the identification (ID) for a SPI Hardware microcontroller peripheral (unit). | |

] ()

[SWS_Spi_00359] [The type Spi_HWUnitType specifies the identification (ID) for a SPI Hardware microcontroller peripheral (unit).] ()

[SWS_Spi_00169] [The type Spi_HWUnitType is used for specifying the identification (ID) for a SPI Hardware microcontroller peripheral (unit).] ()

8.2.11 Spi_AsyncModeType

[SWS_Spi_00382] [

| | | |
|---------------------|---|--|
| Name: | Spi_AsyncModeType | |
| Type: | Enumeration | |
| Range: | SPI_POLLING_MODE | -- The asynchronous mechanism is ensured by polling, so interrupts related to SPI busses handled asynchronously are disabled. |
| | SPI_INTERRUPT_MODE | -- The asynchronous mechanism is ensured by interrupt, so interrupts related to SPI busses handled asynchronously are enabled. |
| Description: | Specifies the asynchronous mechanism mode for SPI busses handled asynchronously in LEVEL 2. | |

] ()

[SWS_Spi_00360] [The type Spi_AsyncModeType specifies the asynchronous mechanism mode for SPI busses handled asynchronously in LEVEL 2 and obtained by the API Spi_SetAsyncMode.] ()

[SWS_Spi_00170] [The type Spi_AsyncModeType is used for specifying the asynchronous mechanism mode for SPI busses handled asynchronously in LEVEL 2.] ()

[SWS_Spi_00150] [The type Spi_AsyncModeType is made available or not depending on the pre-compile time parameter: SpiLevelDelivered. This is only relevant for LEVEL 2.] ()

[SWS_Spi_00361] [If API Spi_SetAsyncMode function is called by the parameter value SPI_POLLING_MODE then asynchronous mechanism is ensured by polling. So interrupts related to SPI busses handled asynchronously are disabled.] ()

[SWS_Spi_00362] [If API Spi_SetAsyncMode function is called by the parameter value SPI_INTERRUPT_MODE asynchronous mechanism is ensured by interrupt, so interrupts related to SPI buses handled asynchronously are enabled.] ()

8.3 Function definitions

8.3.1 Spi_Init

[SWS_Spi_00175] [

| | | |
|-----------------------------|---|------------------------------|
| Service name: | Spi_Init | |
| Syntax: | <pre>void Spi_Init(const Spi_ConfigType* ConfigPtr)</pre> | |
| Service ID[hex]: | 0x00 | |
| Sync/Async: | Synchronous | |
| Reentrancy: | Non Reentrant | |
| Parameters (in): | ConfigPtr | Pointer to configuration set |
| Parameters (in-out): | None | |
| Parameters (out): | None | |
| Return value: | None | |
| Description: | Service for SPI initialization. | |

] ()

[SWS_Spi_00298] [The operation Spi_Init is Non Re-entrant.] ()

[SWS_Spi_00299] [The function Spi_Init provides the service for SPI initialization.] ()

[SWS_Spi_00013] [The function Spi_Init shall initialize all SPI relevant registers with the values of the structure referenced by the parameter ConfigPtr.] (SRS_BSW_00405, SRS_BSW_00101, SRS_SPAL_12057, SRS_SPAL_12125)

[SWS_Spi_00082] [The function Spi_Init shall define default values for required parameters of the structure referenced by the ConfigPtr. For example: all buffer pointers shall be initialized as a null value pointer.] ()

[SWS_Spi_00015] [After the module initialization using the function Spi_Init, the SPI Handler/Driver shall set its state to SPI_IDLE, the Sequences result to SPI_SEQ_OK and the jobs result to SPI_JOB_OK.] (SRS_BSW_00406, SRS_BSW_00101, SRS_SPAL_12057)

[SWS_Spi_00151] [For LEVEL 2 (see chapter 7.2.5 and SPI103), the function Spi_Init shall set the SPI Handler/Driver asynchronous mechanism mode to SPI_POLLING_MODE by default. Interrupts related to SPI busses shall be disabled.] ()

A re-initialization of a SPI Handler/Driver by executing the Spi_Init() function requires a de-initialization before by executing a Spi_DeInit().

Parameters of the function Spi_Init shall be checked as it is explained in section [API parameter checking](#)

8.3.2 Spi_DeInit

[SWS_Spi_00176] [

| | | |
|-----------------------------|---|--|
| Service name: | Spi_DeInit | |
| Syntax: | Std_ReturnType Spi_DeInit(void) | |
| Service ID[hex]: | 0x01 | |
| Sync/Async: | Synchronous | |
| Reentrancy: | Non Reentrant | |
| Parameters (in): | None | |
| Parameters (in-out): | None | |
| Parameters (out): | None | |
| Return value: | Std_ReturnType | E_OK: de-initialisation command has been accepted E_NOT_OK: de-initialisation command has not been accepted |
| Description: | Service for SPI de-initialization. | |

] ()

[SWS_Spi_00300] [The operation Std_ReturnType Spi_DeInit() is Non Reentrant.] ()

[SWS_Spi_00301] [When the API Spi_DeInit has been accepted the return value of this function shall be E_OK.] ()

[SWS_Spi_00302] [When the API Spi_DeInit has not been accepted the return value of this function shall be E_NOT_OK.] ()

[SWS_Spi_00303] [The function Spi_DeInit provides the service for SPI de-initialization.] ()

[SWS_Spi_00021] [The function Spi_DeInit shall de-initialize SPI Handler/Driver.] (SRS_BSW_00336, SRS_SPAL_12163, SRS_SPAL_12064)

[SWS_Spi_00252] [In case of the SPI Handler/Driver state is not SPI_BUSY, the deinitialization function shall put all already initialized microcontroller SPI peripherals into the same state such as Power On Reset.] ()

[SWS_Spi_00253] [The function call Spi_DeInit shall be rejected if the status of SPI Handler/Driver is SPI_BUSY.] ()

[SWS_Spi_00022] [After the module de-initialization using the function `Spi_DeInit`, the SPI Handler/Driver shall set its state to `SPI_UNINIT.`] (SRS_BSW_00336, SRS_SPAL_12163)

The SPI Handler/Driver shall have been initialized before the function `Spi_DeInit` is called, otherwise see [\[SWS_Spi_00046\]](#).

8.3.3 Spi_WriteIB

[SWS_Spi_00177] [

| | | |
|-----------------------------|---|--|
| Service name: | Spi_WriteIB | |
| Syntax: | <pre>Std_ReturnType Spi_WriteIB(Spi_ChannelType Channel, const Spi_DataBufferType* DataBufferPtr)</pre> | |
| Service ID[hex]: | 0x02 | |
| Sync/Async: | Synchronous | |
| Reentrancy: | Reentrant | |
| Parameters (in): | Channel | Channel ID. |
| | DataBufferPtr | Pointer to source data buffer. If this pointer is null, it is assumed that the data to be transmitted is not relevant and the default transmit value of this channel will be used instead. |
| Parameters (in-out): | None | |
| Parameters (out): | None | |
| Return value: | Std_ReturnType | E_OK: write command has been accepted E_NOT_OK: write command has not been accepted |
| Description: | Service for writing one or more data to an IB SPI Handler/Driver Channel specified by parameter. | |

] ()

[SWS_Spi_00304] [The operation `Spi_WriteIB` is Re-entrant.] ()

[SWS_Spi_00305] [When the API `Spi_WriteIB` command has been accepted the function returns the value `E_OK.`] ()

[SWS_Spi_00306] [When the API `Spi_WriteIB` command has not been accepted the function returns the value `E_NOT_OK.`] ()

[SWS_Spi_00307] [The function `Spi_WriteIB` provides the service for writing one or more data to an IB SPI Handler/Driver Channel by the respective parameter.] ()

[SWS_Spi_00018] [The function `Spi_WriteIB` shall write one or more data to an IB SPI Handler/Driver Channel specified by the respective parameter.] (SRS_Spi_12101, SRS_Spi_12153)

[SWS_Spi_00024] [The function `Spi_WriteIB` shall take over the given parameters, and save the pointed data to the internal buffer defined with the function `Spi_Init.`] ()

[SWS_Spi_00023] [If the given parameter “DataBufferPtr” is null, the function Spi_WriteIB shall assume that the data to be transmitted is not relevant and the default transmit value of the given channel shall be used instead.] ()

[SWS_Spi_00137] [The function Spi_WriteIB shall be pre-compile time configurable by the parameter Spi_ChannelBuffersAllowed. This function is only relevant for Channels with IB.] ()

Parameters of the function Spi_WriteIB shall be checked as it is explained in section [API parameter checking](#).

The SPI Handler/Driver shall have been initialized before the function Spi_WriteIB is called, otherwise see [\[SWS_Spi_00046\]](#).

8.3.4 Spi_AsyncTransmit

[SWS_Spi_00178] [

| | | |
|-----------------------------|---|--|
| Service name: | Spi_AsyncTransmit | |
| Syntax: | Std_ReturnType Spi_AsyncTransmit(Spi_SequenceType Sequence) | |
| Service ID[hex]: | 0x03 | |
| Sync/Async: | Asynchronous | |
| Reentrancy: | Reentrant | |
| Parameters (in): | Sequence | Sequence ID. |
| Parameters (in-out): | None | |
| Parameters (out): | None | |
| Return value: | Std_ReturnType | E_OK: Transmission command has been accepted E_NOT_OK: Transmission command has not been accepted |
| Description: | Service to transmit data on the SPI bus. | |

] ()

[SWS_Spi_00308] [The operation Std_ReturnType Spi_AsyncTransmit(Spi_SequenceType Sequence) is Re-entrant.] ()

[SWS_Spi_00309] [When the API Spi_AsyncTransmit command has been accepted the function shall return the value E_OK.] ()

[SWS_Spi_00310] [When the API Spi_AsyncTransmit command has not been accepted the function shall return the value E_NOT_OK.] ()

[SWS_Spi_00311] [The function Spi_AsyncTransmit provides service to transmit data on the SPI bus.] ()

[SWS_Spi_00020] [The function Spi_AsyncTransmit shall take over the given parameter, initiate a transmission, set the SPI Handler/Driver status to SPI_BUSY,

set the sequence result to `SPI_SEQ_PENDING` and return.] (SRS_Spi_12099, SRS_Spi_12101, SRS_Spi_12103)

[SWS_Spi_00194] [When the function `Spi_AsyncTransmit` is called, shall take over the given parameter and set the Job status to `SPI_JOB_QUEUED`, which can be obtained by calling the API service `Spi_GetJobResult`.] ()

[SWS_Spi_00157] [When the function `Spi_AsyncTransmit` is called, the SPI Handler/Driver shall handle the Job results. Result shall be `SPI_JOB_PENDING` when the transmission of Jobs is started.] ()

[SWS_Spi_00292] [When the function `Spi_AsyncTransmit` is called, the SPI Handler/Driver shall handle the Job results. Result shall be `SPI_JOB_OK` when the transmission of Jobs is success.] ()

[SWS_Spi_00293] [When the function `Spi_AsyncTransmit` is called, the SPI Handler/Driver shall handle the Job results. Result shall be `SPI_JOB_FAILED` when the transmission of Jobs is failed.] ()

[SWS_Spi_00081] [When the function `Spi_AsyncTransmit` is called and the requested Sequence is already in state `SPI_SEQ_PENDING`, the SPI Handler/Driver shall not take in account this new request and this function shall return with value `E_NOT_OK`, in this case.] ()

[SWS_Spi_00266] [When the function `Spi_AsyncTransmit` is called and the requested Sequence is already in state `SPI_SEQ_PENDING` the SPI Handler/Driver shall report the `SPI_E_SEQ_PENDING` error according to [SWS_BSW_00042] and [SWS_BSW_00045].] ()

[SWS_Spi_00086] [When the function `Spi_AsyncTransmit` is called and the requested Sequence shares Jobs with another sequence that is in the state `SPI_SEQ_PENDING`, the SPI Handler/Driver shall not take into account this new request and this function shall return the value `E_NOT_OK`. In this case and according to [SWS_BSW_00042] and [SWS_BSW_00045], the SPI Handler/Driver shall report the `SPI_E_SEQ_PENDING` error.] ()

[SWS_Spi_00035] [When the function `Spi_AsyncTransmit` is used with EB and the source data pointer has been provided as `NULL` using the `Spi_SetupEB` method, the default transmit data configured for each channel shall be transmitted. (See also [\[SWS_SPI_00028\]](#))] (SRS_Spi_12200, SRS_Spi_12201)

[SWS_Spi_00036] [When the function `Spi_AsyncTransmit` is used with EB and the destination data pointer has been provided as `NULL` using the `Spi_SetupEB` method, the SPI Handler/Driver shall ignore receiving data (See also [\[SWS_Spi_00030\]](#))] ()

[SWS_Spi_00055] [When the function `Spi_AsyncTransmit` is used for a Sequence with linked Jobs, the function shall transmit from the first Job up to the last Job in the sequence.] (SRS_Spi_12181)

[SWS_Spi_00057] [At the end of a sequence transmission initiated by the function `Spi_AsyncTransmit` and if configured, the SPI Handler/Driver shall invoke the sequence notification call-back function after the last Job end notification if this one is also configured.] (SRS_SPAL_00157, SRS_Spi_12108)

[SWS_Spi_00133] [The function `Spi_AsyncTransmit` is pre-compile time selectable by the configuration parameter `SpiLevelDelivered`. This function is only relevant for LEVEL 1 and LEVEL 2.] ()

[SWS_Spi_00173] [The SPI Handler/Driver's environment shall call the function `Spi_AsyncTransmit` after a function call of `Spi_SetupEB` for EB Channels or a function call of `Spi_WriteIB` for IB Channels but before the function call `Spi_ReadIB`.] ()

Parameters of the function `Spi_AsyncTransmit` shall be checked as explained in section [API parameter checking](#)

The SPI Handler/Driver shall have been initialized before the function `Spi_AsyncTransmit` is called otherwise see [\[SWS_Spi_00046\]](#).

8.3.5 Spi_ReadIB

[SWS_Spi_00179] [

| | | |
|-----------------------------|--|--|
| Service name: | Spi_ReadIB | |
| Syntax: | <pre>Std_ReturnType Spi_ReadIB(Spi_ChannelType Channel, Spi_DataBufferType* DataBufferPointer)</pre> | |
| Service ID[hex]: | 0x04 | |
| Sync/Async: | Synchronous | |
| Reentrancy: | Reentrant | |
| Parameters (in): | Channel | Channel ID. |
| Parameters (in-out): | None | |
| Parameters (out): | DataBufferPointer | Pointer to destination data buffer in RAM |
| Return value: | Std_ReturnType | E_OK: read command has been accepted E_NOT_OK: read command has not been accepted |
| Description: | Service for reading synchronously one or more data from an IB SPI Handler/Driver Channel specified by parameter. | |

] ()

[SWS_Spi_00312] [The operation `Spi_ReadIB` is Re-entrant.] ()

[SWS_Spi_00313] [The function `Spi_ReadIB` return values E_OK: read command has been accepted.] ()

[SWS_Spi_00314] [The function Spi_ReadIB return values E_NOT_OK: read command has not been accepted.] ()

[SWS_Spi_00315] [The function Spi_ReadIB provides the service for reading synchronously one or more data from an IB SPI Handler/Driver Channel specified by parameter.] ()

[SWS_Spi_00016] [The function Spi_ReadIB shall read synchronously one or more data from an IB SPI Handler/Driver Channel specified by the respective parameter.] (SRS_Spi_12099, SRS_Spi_12152)

[SWS_Spi_00027] [The SPI Handler/Driver's environment shall call the function Spi_ReadIB after a Transmit method call to have relevant data within IB Channel.] ()

[SWS_Spi_00138] [The function Spi_ReadIB is pre-compile time configurable by the parameter SpiChannelBuffersAllowed. This function is only relevant for Channels with IB.] ()

Parameters of the function Spi_ReadIB shall be checked as it is explained in section API parameter checking.

The SPI Handler/Driver shall have been initialized before the function Spi_ReadIB is called otherwise see [\[SWS_Spi_00046\]](#).

8.3.6 Spi_SetupEB

[SWS_Spi_00180] [

| | | |
|-----------------------------|---|--|
| Service name: | Spi_SetupEB | |
| Syntax: | <pre>Std_ReturnType Spi_SetupEB(Spi_ChannelType Channel, const Spi_DataBufferType* SrcDataBufferPtr, Spi_DataBufferType* DesDataBufferPtr, Spi_NumberOfDataType Length)</pre> | |
| Service ID[hex]: | 0x05 | |
| Sync/Async: | Synchronous | |
| Reentrancy: | Reentrant | |
| Parameters (in): | Channel | Channel ID. |
| | SrcDataBufferPtr | Pointer to source data buffer. |
| | Length | Length (number of data elements) of the data to be transmitted from SrcDataBufferPtr and/or received from DesDataBufferPtr Min.: 1 Max.: Max of data specified at configuration for this channel |
| Parameters (in-out): | DesDataBufferPtr | Pointer to destination data buffer in RAM. |
| Parameters (out): | None | |
| Return value: | Std_ReturnType | E_OK: Setup command has been accepted E_NOT_OK: Setup command has not been accepted |

| | |
|---------------------|--|
| Description: | Service to setup the buffers and the length of data for the EB SPI Handler/Driver Channel specified. |
|---------------------|--|

] ()

[SWS_Spi_00316] [The operation Spi_SetupEB is Re-entrant.] ()

[SWS_Spi_00317] [Return values of the function Spi_SetupEB are E_OK: Setup command has been accepted and E_NOT_OK: Setup command has not been accepted.] ()

[SWS_Spi_00318] [The function Spi_SetupEB provides the service to setup the buffers and the length of data for the EB SPI Handler/Driver Channel specified.] ()

[SWS_Spi_00058] [The function Spi_SetupEB shall set up the buffers and the length of data for the specific EB SPI Handler/Driver Channel.] (SRS_Spi_12103)

[SWS_Spi_00067] [The function Spi_SetupEB shall update the buffer pointers and length attributes of the specified Channel with the provided values.] (SRS_Spi_12103)

As these attributes are persistent, they will be used for all succeeding calls to a Transmit method (for the specified Channel).

[SWS_Spi_00028] [When the SPI Handler/Driver's environment is calling the function Spi_SetupEB with the parameter SrcDataBufferPtr being a Null pointer, the function shall transmit the default transmit value configured for the channel after a Transmit method is requested. (See also [[SWS_Spi_00035](#)])] ()

[SWS_Spi_00030] [When the function Spi_SetupEB is called with the parameter DesDataBufferPtr being a Null pointer, the SPI Handler/Driver shall ignore the received data after a Transmit method is requested.(See also [[SWS_Spi_00036](#)])] ()

[SWS_Spi_00037] [The SPI Handler/Driver's environment shall call the Spi_SetupEB function once for each Channel with EB declared before the SPI Handler/Driver's environment calls a Transmit method on them.] ()

[SWS_Spi_00139] [The function Spi_SetupEB is pre-compile time configurable by the parameter SpiChannelBuffersAllowed. This function is only relevant for Channels with EB.] ()

Parameters of the function Spi_SetupEB shall be checked as it is explained in section [API parameter checking](#).

The SPI Handler/Driver shall have been initialized before the function `Spi_SetupEB` is called otherwise see [[SWS Spi 00046](#)].

8.3.7 Spi_GetStatus

[SWS_Spi_00181] [

| | | |
|-----------------------------|--|----------------|
| Service name: | Spi_GetStatus | |
| Syntax: | Spi_StatusType Spi_GetStatus(void) | |
| Service ID[hex]: | 0x06 | |
| Sync/Async: | Synchronous | |
| Reentrancy: | Reentrant | |
| Parameters (in): | None | |
| Parameters (in-out): | None | |
| Parameters (out): | None | |
| Return value: | Spi_StatusType | Spi_StatusType |
| Description: | Service returns the SPI Handler/Driver software module status. | |

] ()

[SWS_Spi_00319] [The operation Spi_GetStatus is Re-entrant.] ()

[SWS_Spi_00320] [The function Spi_GetStatus returns the SPI Handler/Driver software module status.] ()

[SWS_Spi_00025] [The function `Spi_GetStatus` shall return the SPI Handler/Driver software module status.] (SRS_SPAL_12064, SRS_Spi_12104)

8.3.8 Spi_GetJobResult

[SWS_Spi_00182] [

| | | |
|-----------------------------|---|--|
| Service name: | Spi_GetJobResult | |
| Syntax: | Spi_JobResultType Spi_GetJobResult(Spi_JobType Job) | |
| Service ID[hex]: | 0x07 | |
| Sync/Async: | Synchronous | |
| Reentrancy: | Reentrant | |
| Parameters (in): | Job | Job ID. An invalid job ID will return an undefined result. |
| Parameters (in-out): | None | |
| Parameters (out): | None | |
| Return value: | Spi_JobResultType | Spi_JobResultType |
| Description: | This service returns the last transmission result of the specified Job. | |

] ()

[SWS_Spi_00321] [The operation Spi_GetJobResult is Re-entrant.] ()

[SWS_Spi_00322] [The function `Spi_GetJobResult` service returns the last transmission result of the specified Job.] ()

[SWS_Spi_00026] [The function `Spi_GetJobResult` shall return the last transmission result of the specified Job.] (SRS_SPAL_00157, SRS_Spi_12104)

[SWS_Spi_00038] [The SPI Handler/Driver's environment shall call the function `Spi_GetJobResult` to inquire whether the Job transmission has succeeded (`SPI_JOB_OK`) or failed (`SPI_JOB_FAILED`).] (SRS_SPAL_00157)

NOTE: Every new transmit job that has been accepted by the SPI Handler/Driver overwrites the previous job result with `SPI_JOB_QUEUED` or `SPI_JOB_PENDING`.

Parameters of the function `Spi_GetJobResult` shall be checked as it is explained in section [API parameter checking](#).

If SPI Handler/Driver has not been initialized before the function `Spi_GetJobResult` is called, the return value is undefined.

8.3.9 Spi_GetSequenceResult

[SWS_Spi_00183] [

| | | |
|-----------------------------|--|--|
| Service name: | Spi_GetSequenceResult | |
| Syntax: | Spi_SeqResultType Spi_GetSequenceResult(Spi_SequenceType Sequence) | |
| Service ID[hex]: | 0x08 | |
| Sync/Async: | Synchronous | |
| Reentrancy: | Reentrant | |
| Parameters (in): | Sequence | Sequence ID. An invalid sequence ID will return an undefined result. |
| Parameters (in-out): | None | |
| Parameters (out): | None | |
| Return value: | Spi_SeqResultType | Spi_SeqResultType |
| Description: | This service returns the last transmission result of the specified Sequence. | |

] ()

[SWS_Spi_00323] [The operation `Spi_GetSequenceResult` is Re-entrant.] ()

[SWS_Spi_00324] [The function `Spi_GetSequenceResult` shall return the last transmission result of the specified Sequence.] (SRS_SPAL_00157, SRS_Spi_12104)

[SWS_Spi_00042] [The SPI Handler/Driver's environment shall call the function `Spi_GetSequenceResult` to inquire whether the full Sequence transmission has succeeded (`SPI_SEQ_OK`) or failed (`SPI_SEQ_FAILED`).] (SRS_SPAL_00157, SRS_Spi_12170)

Note:

- Every new transmit sequence that has been accepted by the SPI Handler/Driver overwrites the previous sequence result with `SPI_SEQ_PENDING`.
- If the SPI Handler/Driver has not been initialized before the function `Spi_GetSequenceResult` is called, the return value is undefined.

Parameters of the function `Spi_GetSequenceResult` shall be checked as it is explained in section [API parameter checking](#).

8.3.10 Spi_GetVersionInfo

[SWS_Spi_00184] [

| | | |
|-----------------------------|--|---|
| Service name: | Spi_GetVersionInfo | |
| Syntax: | <pre>void Spi_GetVersionInfo(Std_VersionInfoType* versioninfo)</pre> | |
| Service ID[hex]: | 0x09 | |
| Sync/Async: | Synchronous | |
| Reentrancy: | Reentrant | |
| Parameters (in): | None | |
| Parameters (in-out): | None | |
| Parameters (out): | versioninfo | Pointer to where to store the version information of this module. |
| Return value: | None | |
| Description: | This service returns the version information of this module. | |

] ()

[SWS_Spi_00371] [If Det is enabled, the parameter `versioninfo` shall be checked for being NULL. The error `SPI_E_PARAM_POINTER` shall be reported in case the value is a NULL pointer.] ()

8.3.11 Spi_SyncTransmit

[SWS_Spi_00185] [

| | | |
|-----------------------------|---|--|
| Service name: | Spi_SyncTransmit | |
| Syntax: | <pre>Std_ReturnType Spi_SyncTransmit(Spi_SequenceType Sequence)</pre> | |
| Service ID[hex]: | 0x0a | |
| Sync/Async: | Asynchronous | |
| Reentrancy: | Reentrant | |
| Parameters (in): | Sequence | Sequence ID. |
| Parameters (in-out): | None | |
| Parameters (out): | None | |
| Return value: | Std_ReturnType | E_OK: Transmission command has been accepted E_NOT_OK: Transmission command has not been accepted |
| Description: | Service to transmit data on the SPI bus | |

] ()

[SWS_Spi_00327] [The operation `Spi_SyncTransmit` is Re-entrant.] ()

[SWS_Spi_00328] [Return value of the function `Spi_SyncTransmit` is `E_OK`: when Transmission command has been accepted.] ()

[SWS_Spi_00329] [Return value of the function `Spi_SyncTransmit` is `E_NOT_OK`: When Transmission command has not been accepted.] ()

[SWS_Spi_00330] [The function `Spi_SyncTransmit` provides the service to transmit data on the SPI bus.] ()

[SWS_Spi_00134] [When the function `Spi_SyncTransmit` is called, shall take over the given parameter and set the SPI Handler/Driver status to `SPI_BUSY` can be obtained calling the API service `SPI_GetStatus`.] (SRS_Spi_12152, SRS_Spi_12153, SRS_Spi_12154)

[SWS_Spi_00285] [When the function `Spi_SyncTransmit` is called, shall take over the given parameter and set the Sequence status to `SPI_SEQ_PENDING` can be obtained calling the API service `Spi_GetSequenceResult`.] ()

[SWS_Spi_00286] [When the function `Spi_SyncTransmit` is called, shall take over the given parameter and set the Job status to `SPI_JOB_PENDING` can be obtained calling the API service `Spi_GetJobResult`.] ()

[SWS_Spi_00135] [When the function `Spi_SyncTransmit` is called while a sequence is on transmission and `SPI_SUPPORT_CONCURRENT_SYNC_TRANSMIT` is disabled or another sequence is on transmission on same bus, the SPI Handler/Driver shall not take into account this new transmission request and the function shall return the value `E_NOT_OK` (see [\[SWS_Spi_00114\]](#)). In this case, the SPI Handler/Driver shall report the `SPI_E_SEQ_IN_PROCESS` error according to [\[SWS_BSW_00042\]](#) and [\[SWS_BSW_00045\]](#).] (SRS_Spi_12093)

[SWS_Spi_00136] [The function `Spi_SyncTransmit` is pre-compile time selectable by the configuration parameter `SpiLevelDelivered`. This function is only relevant for LEVEL 0 and LEVEL 2.] ()

Parameters of the function `Spi_SyncTransmit` shall be checked as it is explained in section [API parameter checking](#)

8.3.12 Spi_GetHWUnitStatus

[SWS_Spi_00186] [

| | |
|-------------------------|---|
| Service name: | <code>Spi_GetHWUnitStatus</code> |
| Syntax: | <code>Spi_StatusType Spi_GetHWUnitStatus (</code> <code> Spi_HWUnitType HWUnit</code> <code>)</code> |
| Service ID[hex]: | <code>0x0b</code> |
| Sync/Async: | Synchronous |

| | | |
|-----------------------------|---|--|
| Reentrancy: | Reentrant | |
| Parameters (in): | HWUnit | SPI Hardware microcontroller peripheral (unit) ID. |
| Parameters (in-out): | None | |
| Parameters (out): | None | |
| Return value: | Spi_StatusType | Spi_StatusType |
| Description: | This service returns the status of the specified SPI Hardware microcontroller peripheral. | |

] ()

[SWS_Spi_00331] [The operation Spi_GetHWUnitStatus is Re-entrant.] ()

[SWS_Spi_00332] [The function Spi_GetHWUnitStatus service returns the status of the specified SPI Hardware microcontroller peripheral.] ()

[SWS_Spi_00141] [The function Spi_GetHWUnitStatus shall return the status of the specified SPI Hardware microcontroller peripheral.] ()

[SWS_Spi_00287] [The SPI Handler/Driver's environment shall call this function to inquire whether the specified SPI Hardware microcontroller peripheral is SPI_IDLE or SPI_BUSY.] ()

[SWS_Spi_00142] [The function Spi_GetHWUnitStatus is pre-compile time configurable On / Off by the configuration parameter SpiHwStatusApi.] ()

Parameters of the function Spi_GetHWUnitStatus shall be checked as it is explained in section [API parameter checking](#).

If SPI Handler/Driver has not been initialized before the function Spi_GetHWUnitStatus is called, the return value is undefined.

8.3.13 Spi_Cancel

[SWS_Spi_00187] [

| | | |
|-----------------------------|---|--------------|
| Service name: | Spi_Cancel | |
| Syntax: | void Spi_Cancel(Spi_SequenceType Sequence) | |
| Service ID[hex]: | 0x0c | |
| Sync/Async: | Asynchronous | |
| Reentrancy: | Reentrant | |
| Parameters (in): | Sequence | Sequence ID. |
| Parameters (in-out): | None | |
| Parameters (out): | None | |
| Return value: | None | |
| Description: | Service cancels the specified on-going sequence transmission. | |

] ()

[SWS_Spi_00333] [The operation Spi_Cancel is Re-entrant.] ()

[SWS_Spi_00334] [The function Spi_Cancel service cancels the specified on-going sequence transmission.] ()

[SWS_Spi_00144] [The function Spi_Cancel shall cancel the specified on-going sequence transmission without cancelling any Job transmission and set the sequence result to SPI_SEQ_CANCELLED.] ()

With other words, the Spi_Cancel function stops a Sequence transmission after a (possible) on transmission Job ended and before a (potential) next Job transmission starts.

[SWS_Spi_00145] [When the sequence is cancelled by the function Spi_Cancel and if configured, the SPI Handler/Driver shall call the sequence notification call-back function instead of starting a potential next job belonging to it.] ()

[SWS_Spi_00146] [The function Spi_Cancel is pre-compile time configurable On / Off by the configuration parameter SpiCancelApi.] ()

The SPI Handler/Driver is not responsible on external devices damages or undefined state due to cancelling a sequence transmission. It is up to the SPI Handler/Driver's environment to be aware to what it is doing!

8.3.14 Spi_SetAsyncMode

[SWS_Spi_00188] [

| | | |
|-----------------------------|---|--|
| Service name: | Spi_SetAsyncMode | |
| Syntax: | Std_ReturnType Spi_SetAsyncMode(Spi_AsyncModeType Mode) | |
| Service ID[hex]: | 0x0d | |
| Sync/Async: | Synchronous | |
| Reentrancy: | Non Reentrant | |
| Parameters (in): | Mode | New mode required. |
| Parameters (in-out): | None | |
| Parameters (out): | None | |
| Return value: | Std_ReturnType | E_OK: Setting command has been done E_NOT_OK: setting command has not been accepted |
| Description: | Service to set the asynchronous mechanism mode for SPI busses handled asynchronously. | |

] ()

[SWS_Spi_00335] [The operation Spi_SetAsyncMode is Non Re-entrant.] ()

[SWS_Spi_00336] [Return value of the function Spi_SetAsyncMode is E_OK: Setting command has been done.] ()

[SWS_Spi_00337] [Return value of the function `Spi_SetAsyncMode` is `E_NOT_OK`: setting command has not been accepted.] ()

[SWS_Spi_00338] [The function `Spi_SetAsyncMode` service to set the asynchronous mechanism mode for SPI buses handled asynchronously.] ()

[SWS_Spi_00152] [The function `Spi_SetAsyncMode` according to the given parameter shall set the asynchronous mechanism mode for SPI channels configured to behave asynchronously.] ()

[SWS_Spi_00171] [If the function `Spi_SetAsyncMode` is called while the SPI Handler/Driver status is `SPI_BUSY` and an asynchronous transmission is in progress, the SPI Handler/Driver shall not change the `AsyncModeType` and keep the mode type as it is. The function shall return the value `E_NOT_OK`.] ()

[SWS_Spi_00172] [If `Spi_SetAsyncMode` is called while a synchronous transmission is in progress, the SPI Handler/Driver shall set the `AsyncModeType` according to parameter 'Mode', even if the SPI Handler/Driver status is `SPI_BUSY`. The function shall return the value `E_OK`.] ()

[SWS_Spi_00154] [The function `Spi_SetAsyncMode` is pre-compile time selectable by the configuration parameter `SpiLevelDelivered`. This function is only relevant for LEVEL 2.] ()

8.4 Callback notifications

This chapter lists all functions provided by the SPI module to lower layer modules.

The SPI Handler/Driver module belongs to the lowest layer of AUTOSAR Software Architecture hence this module specification has not identified any callback functions.

8.5 Scheduled functions

This chapter lists all functions provided by the SPI Handler/Driver and called directly by the Basic Software Module Scheduler.

The SPI Handler/Driver module requires a scheduled function for the management of the asynchronous mode managed with polling (see [SWS_Spi_00361](#)). The specified functions below exemplify how to implement them if they are needed.

8.5.1 Spi_MainFunction_Handling

[SWS_Spi_00189] [

| | |
|----------------------|--|
| Service name: | <code>Spi_MainFunction_Handling</code> |
| Syntax: | <code>void Spi_MainFunction_Handling(</code> |

| | |
|-------------------------|------|
| | void |
| |) |
| Service ID[hex]: | 0x10 |
| Description: | -- |

] ()

This function shall poll the SPI interrupts linked to HW Units allocated to the transmission of SPI sequences to enable the evolution of transmission state machine.

8.6 Expected Interfaces

This chapter lists all functions that the SPI Handler/Driver requires from other modules.

8.6.1 Mandatory Interfaces

The SPI Handler/Driver module requires some interfaces to fulfill its core functionality.

[SWS_Spi_00389]

| API function | Description |
|------------------------|---|
| Det_ReportRuntimeError | Service to report runtime errors. If a callout has been configured then this callout shall be called. |

] ()

8.6.2 Optional Interfaces

This chapter defines all interfaces which are required to fulfill an optional functionality of SPI Handler/Driver module.

[SWS_Spi_00339] [

| API function | Description |
|--------------------|--|
| Dem_SetEventStatus | Called by SW-Cs or BSW modules to report monitor status information to the Dem. BSW modules calling Dem_SetEventStatus can safely ignore the return value. |
| Det_ReportError | Service to report development errors. |

] ()

8.6.3 Configurable interfaces

In this chapter all interfaces are listed where the target function could be configured. The target function is usually a call-back function. The name of these interfaces is not fixed because they are configurable. Callback prototypes are provided by <Upper layer> callback header files included by Spi_Cfg.h files.

[SWS_Spi_00075] [The SPI Handler/Driver shall use the callback routines Spi_JobEndNotification to inform other software modules about certain states or state changes.] (SRS_SPAL_00157)

[SWS_Spi_00264] [The SPI Handler/Driver shall use the callback routines Spi_SeqEndNotification to inform other software modules about certain states or state changes.] ()

[SWS_Spi_00265] [For implement the call back function other modules are required to provide the routines in the expected manner.] ()

[SWS_Spi_00044] [The SPI Handler/Driver's implementer must implement the callback notifications Spi_JobEndNotification and Spi_SeqEndNotification as function pointers defined within the initialization data structure (Spi_ConfigType).] (SRS_SPAL_12056)

[SWS_Spi_00048] [The callback notifications Spi_JobEndNotification and Spi_SeqEndNotification shall have no parameters and no return value.] (SRS_BSW_00359, SRS_BSW_00360, SRS_BSW_00369)

[SWS_Spi_00054] [If a callback notification is configured as null pointer, no callback shall be executed.] (SRS_SPAL_12056)

[SWS_Spi_00085] [It is allowed to use the following API calls within the SPI callback notifications:

- Spi_ReadIB
- Spi_WriteIB
- Spi_SetupEB
- Spi_GetJobResult
- Spi_GetSequenceResult
- Spi_GetHWUnitStatus
- Spi_Cancel

All other SPI Handler/Driver API calls are not allowed.] ()

8.6.3.1 Spi_JobEndNotification

[SWS_Spi_00192] [

| | |
|-----------------------------|---|
| Service name: | (*Spi_JobEndNotification) |
| Syntax: | void (*Spi_JobEndNotification) (void) |
| Sync/Async: | Synchronous |
| Reentrancy: | Reentrant |
| Parameters (in): | None |
| Parameters (in-out): | None |
| Parameters (out): | None |
| Return value: | None |
| Description: | Callback routine provided by the user for each Job to notify the caller that a job has been finished. |

] ()

[SWS_Spi_00340] [The operation SpiJobEndNotification is Re-entrant.] ()

[SWS_Spi_00071] [If the SpiJobEndNotification is configured (i.e. not a null pointer), the SPI Handler/Driver shall call the configured callback notification at the end of a Job transmission.] (SRS_SPAL_00157)

Note: This routine might be called on interrupt level, depending on the calling function.

8.6.3.2 Spi_SeqEndNotification

[SWS_Spi_00193] [

| | |
|-----------------------------|---|
| Service name: | (*Spi_SeqEndNotification) |
| Syntax: | void (*Spi_SeqEndNotification) (void) |
| Sync/Async: | Synchronous |
| Reentrancy: | Reentrant |
| Parameters (in): | None |
| Parameters (in-out): | None |
| Parameters (out): | None |
| Return value: | None |
| Description: | Callback routine provided by the user for each Sequence to notify the caller that a sequence has been finished. |

] ()

[SWS_Spi_00341] [The operation SpiSeqEndNotification is Re-entrant.] ()

[SWS_Spi_00073] [If the SpiSeqEndNotification is configured (i.e. not a null pointer), the SPI Handler/Driver shall call the configured callback notification at the end of a Sequence transmission.] (SRS_SPAL_00157)

Note: This routine might be called on interrupt level, depending on the calling function.

9 Sequence diagrams

9.1 Initialization

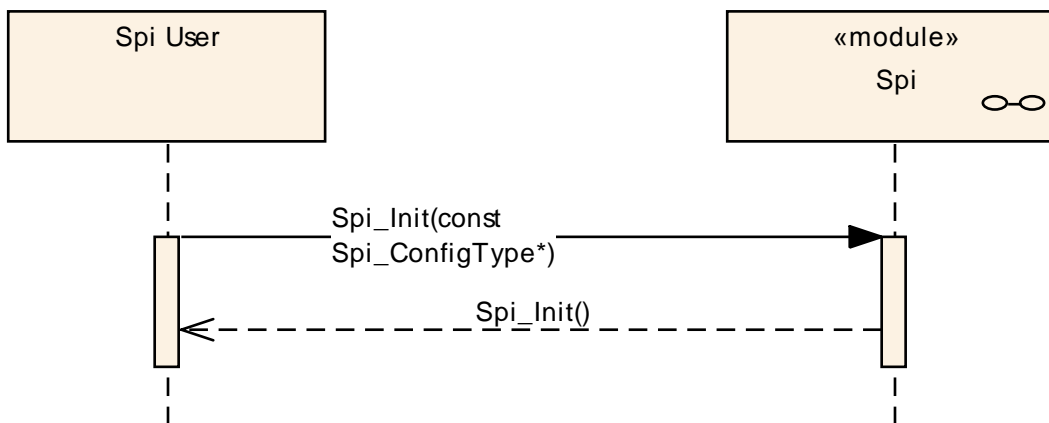

9.2 Modes transitions

The following sequence diagram shows an example of an Init / Delnit calls for a running mode transition.

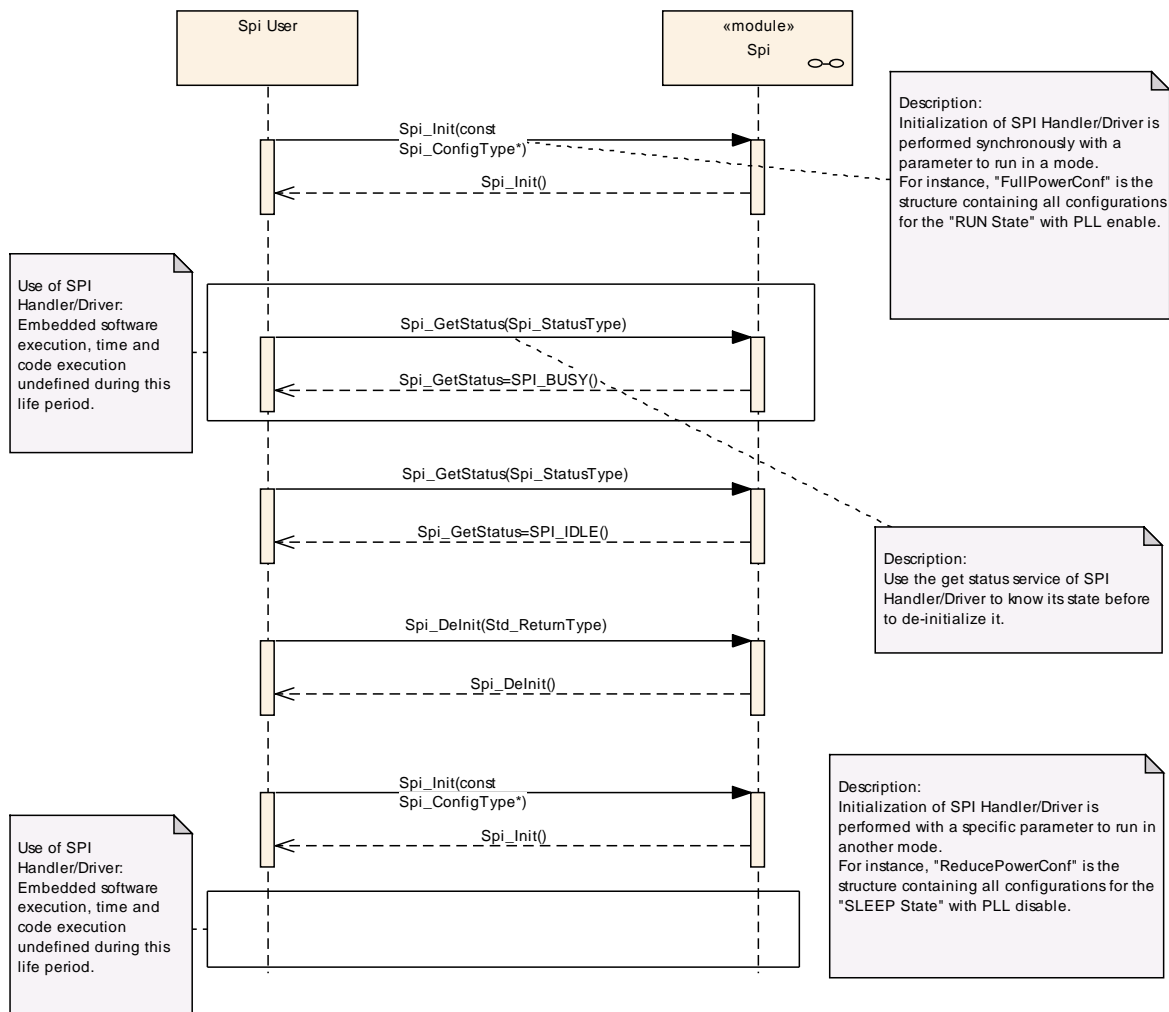

9.3 Write/AsyncTransmit/Read (IB)

9.3.1 One Channel, one Job then one Sequence

The following sequence diagram shows an example of Spi_WriteIB / Spi_AsyncTransmit / Spi_ReadIB calls for a Sequence transmission with only one Job composed of only one Channel. Write or Read step could be skipped when Job is just reading or writing respectively.

Example: Channel ID 2 belongs to Job ID 1 which belongs to Sequence ID 0

| Sequence | Job | Channel |
|----------|-----|---------|
| ID0 | ID1 | ID2 |

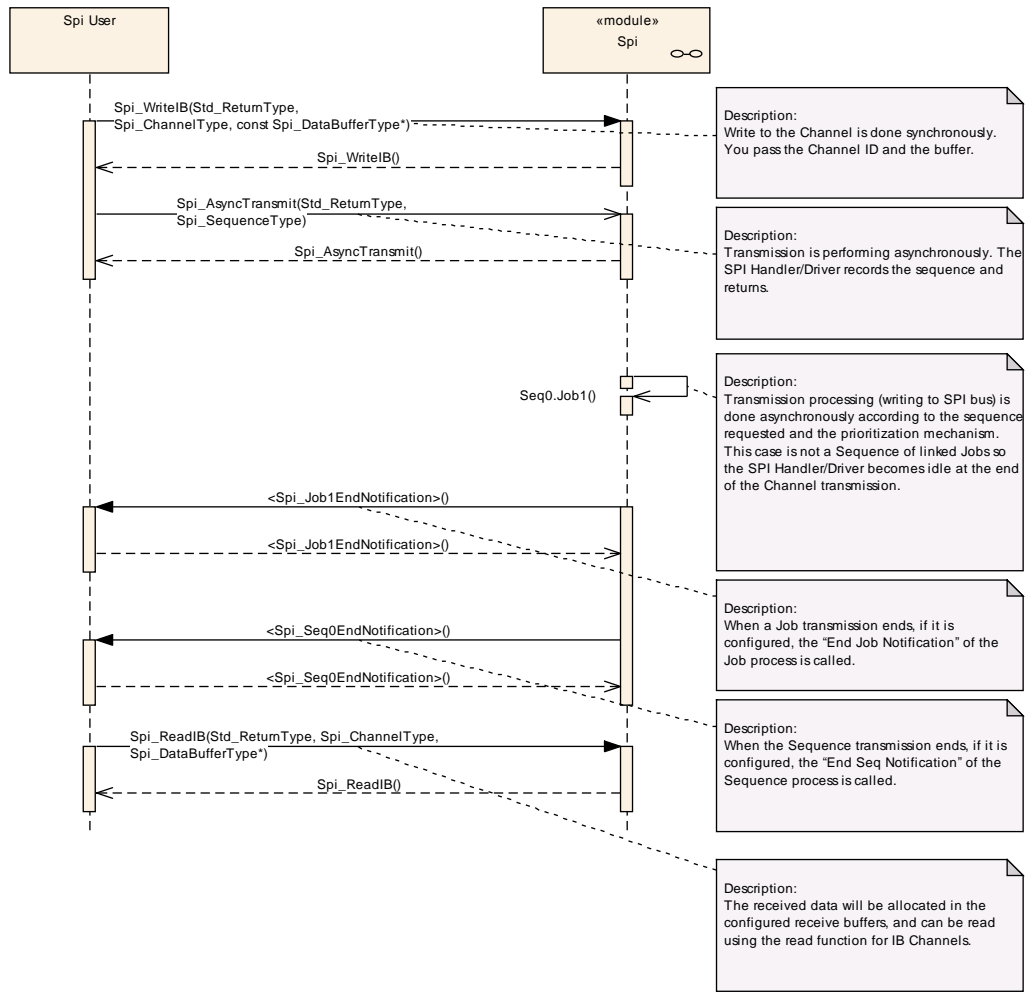

9.3.2 Many Channels, one Job then one Sequence

The following sequence diagram shows an example of Spi_WriteIB / Spi_AsyncTransmit / Spi_ReadIB calls for a Sequence transmission with only one Job composed of many Channels. Write or Read steps could be skipped when Job is just reading or writing respectively.

Example: Channels ID 2 & 3 belong to Job ID 1 which belongs to Sequence ID 0

| Sequence | Job | Channel |
|----------|-----|---------|
| ID0 | ID1 | ID2 |
| | | ID3 |

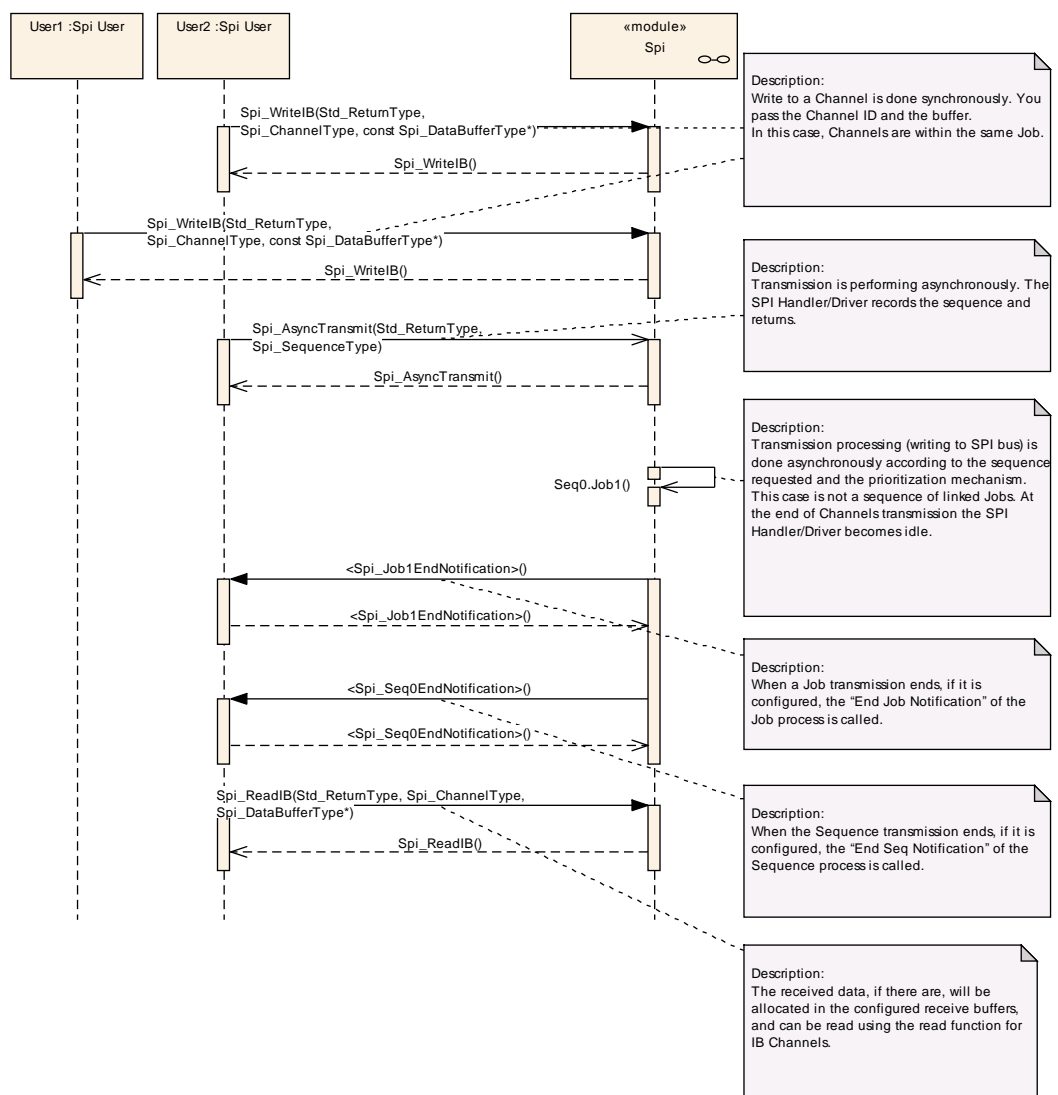

9.3.3 Many Channels, many Jobs and one Sequence

The following sequence diagram shows an example of Spi_WriteIB / Spi_AsyncTransmit / Spi_ReadIB calls for a Sequence transmission of linked Jobs. Write or Read steps could be skipped when Jobs are just reading or writing respectively.

Example: Channels ID 0 to 3 belong to Job ID 1 (higher priority), Channels ID 4 to 10 belong to Job ID 2 (Lower priority) which has not an end notification function. These Jobs belong to the same Sequence ID 0

| Sequence | Job | | Channel |
|-----------------|-------------|-----------------|----------------|
| | Name | Priority | |
| ID0 | ID1 | High | ID0...ID3 |
| | ID2 | Low | ID4...ID10 |

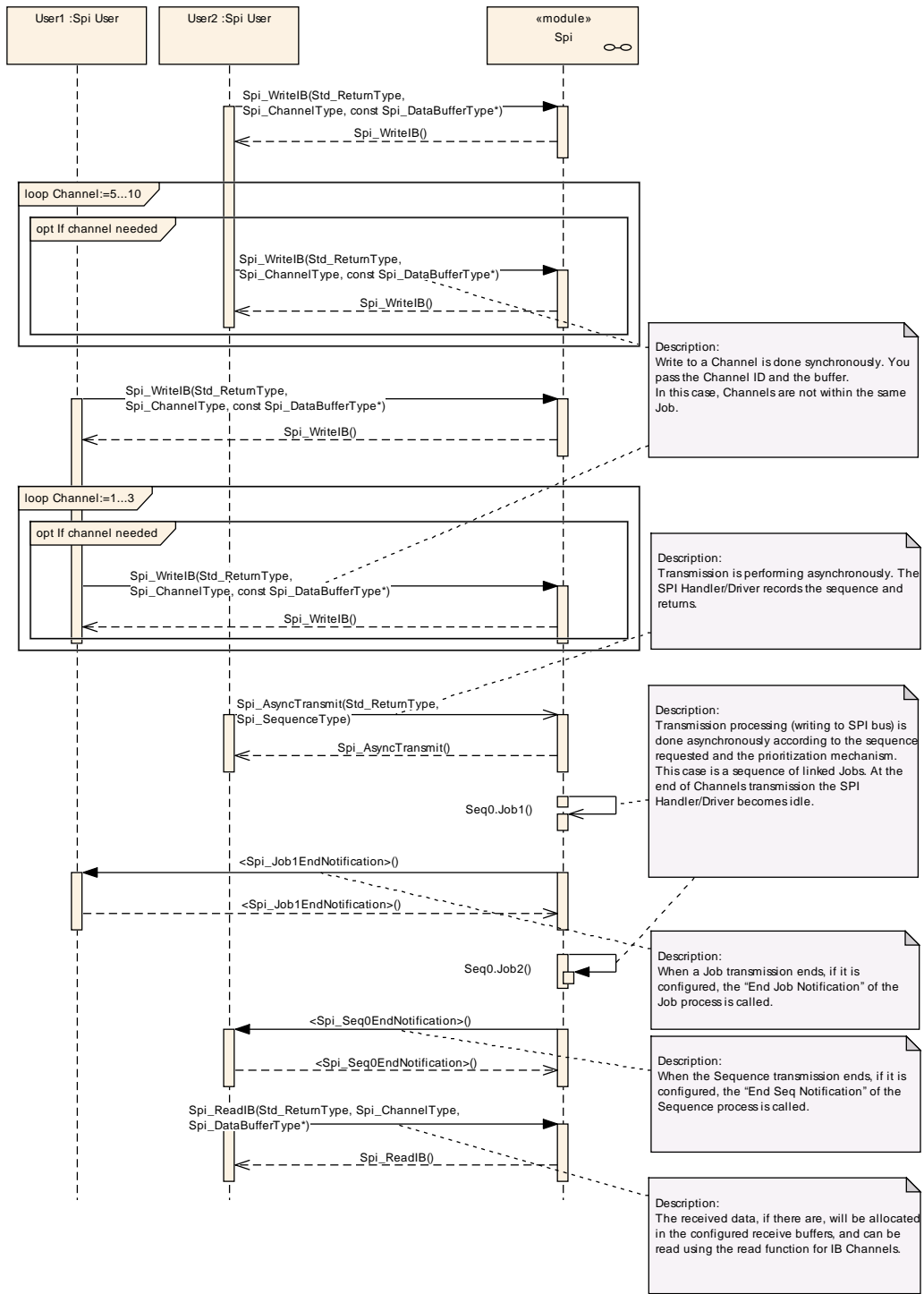

9.3.4 Many Channels, many Jobs and many Sequences

The following sequence diagram shows an example of Spi_WriteIB / Spi_AsyncTransmit / Spi_ReadIB calls for Sequences transmission. Write or Read steps could be skipped when Jobs are just reading or writing respectively.

Example: Channels ID 0 to 3 belong to Job ID 1 (high priority 2), Channels ID 4 to 10 belong to Job ID 2 (Low priority 1) which has not an end notification function. These Jobs belong to the same Sequence ID 0 which is configured as interruptible. Channels ID 11 to 13 belong to Job ID 0 (higher priority 3) which belongs to Sequence ID 1 which is configured as not interruptible.

| Sequence | | Job | | Channel |
|-----------------|----------------------|-------------|-----------------|----------------|
| Name | Interruptible | Name | Priority | |
| ID0 | Yes | ID1 | 2 | ID0...ID3 |
| | | ID2 | 1 | ID4...ID10 |
| ID1 | No | ID0 | 3 | ID11...ID13 |

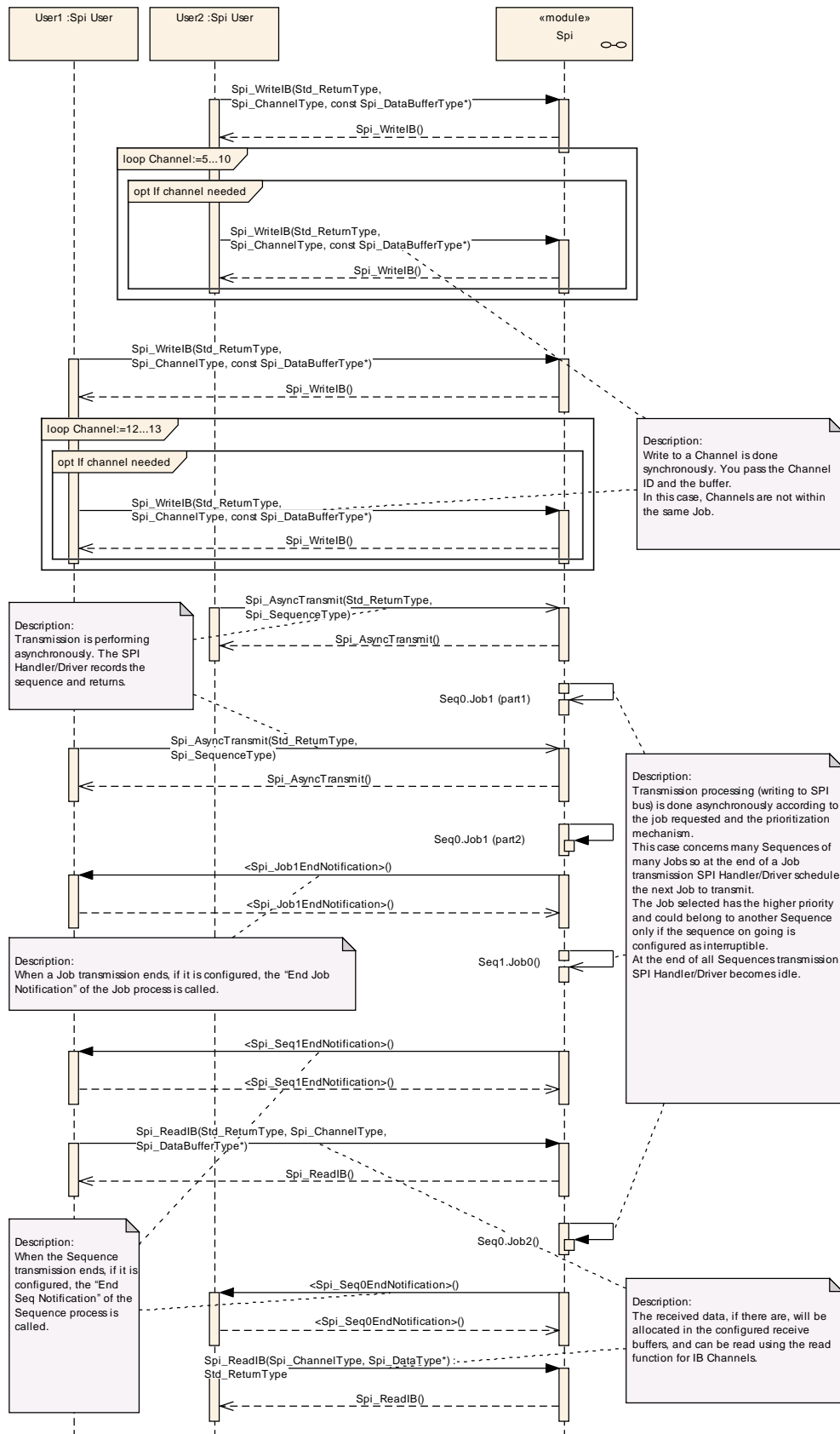

9.4 Setup/AsyncTransmit (EB)

9.4.1 Variable Number of Data / Constant Number of Data

[SWS_Spi_00077] [To transmit a variable number of data, it is mandatory to call the `Spi_SetupEB` function to store new parameters within SPI Handler/Driver before each `Spi_AsyncTransmit` function call.] (SRS_Spi_12198, SRS_Spi_12200, SRS_Spi_12201)

[SWS_Spi_00078] [To transmit a constant number of data, it is only mandatory to call the `Spi_SetupEB` function to store parameters within SPI Handler/Driver before the first `Spi_AsyncTransmit` function call.] (SRS_Spi_12253, SRS_Spi_12262, SRS_Spi_12202)

9.4.2 One Channel, one Job then one Sequence

The following sequence diagram shows an example of `Spi_SetupEB` / `Spi_AsyncTransmit` calls for a Sequence transmission with only one Job composed of only one Channel. Write or Read accesses are “User Dependant” and could be skipped when Job is just reading or writing respectively.

Example: Channel ID 2 belongs to Job ID 1 which belongs to Sequence ID 0

| Sequence | Job | Channel |
|----------|-----|---------|
| ID0 | ID1 | ID2 |

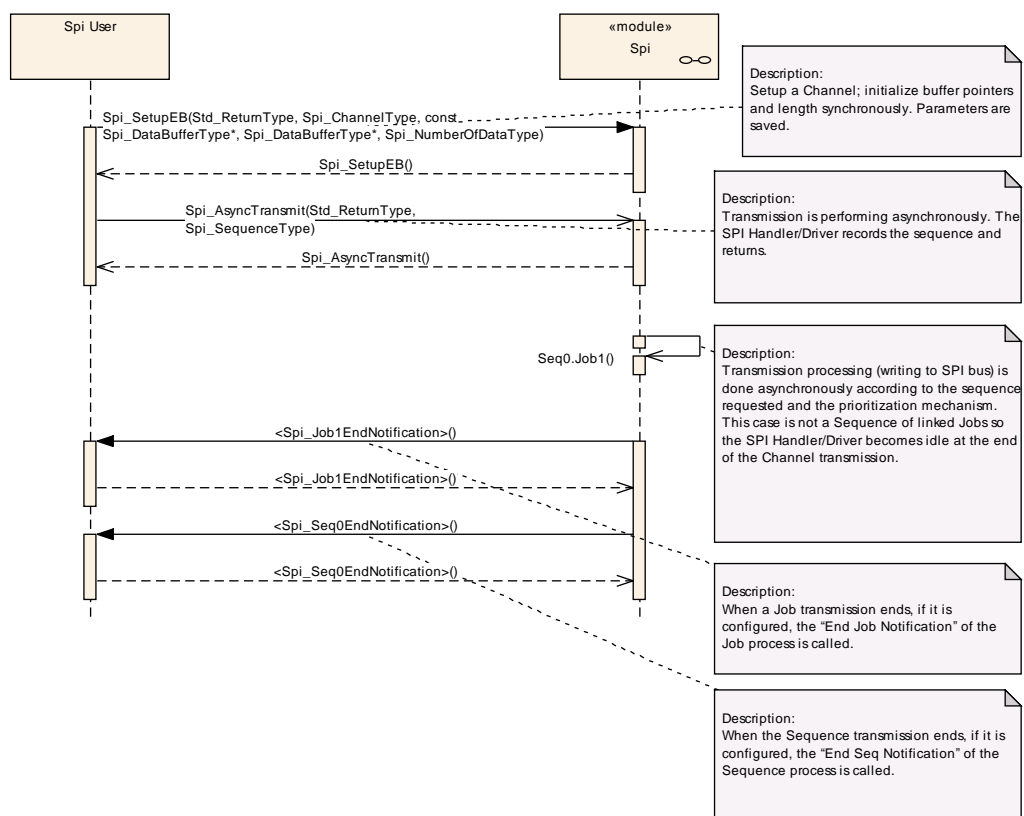

9.4.3 Many Channels, one Job then one Sequence

The following sequence diagram shows an example of `Spi_SetupEB` / `Spi_AsyncTransmit` calls for a Sequence transmission with only one Job composed of many Channels. Write or Read accesses are “User Dependant” and could be skipped when Job is just reading or writing respectively.

Example: Channels ID 2 & 3 belong to Job ID 1 which belongs to Sequence ID 0

| Sequence | Job | Channel |
|----------|-----|---------|
| ID0 | ID1 | ID2 |
| | | ID3 |

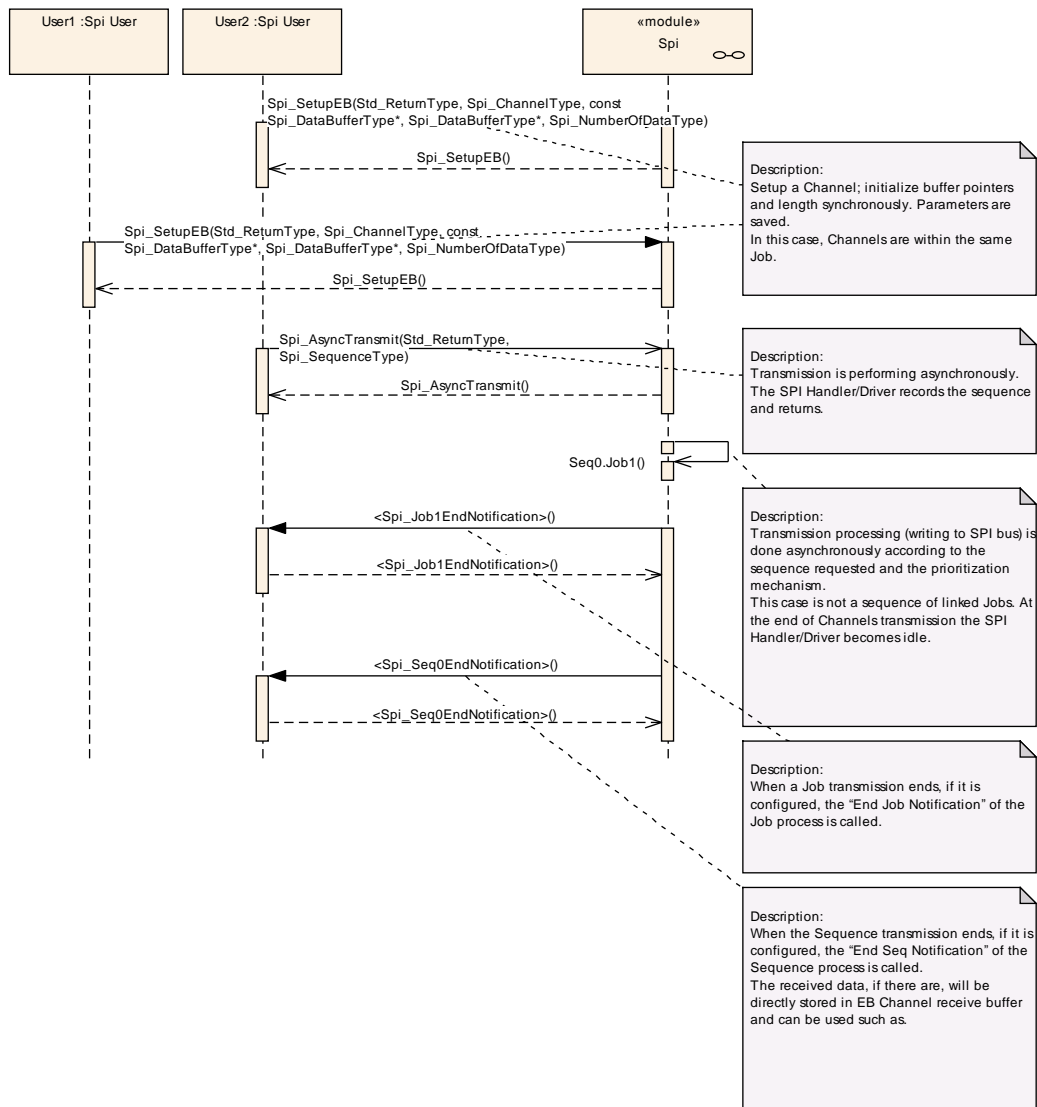

9.4.4 Many Channels, many Jobs and one Sequence

The following sequence diagram shows an example of `Spi_SetupEB` / `Spi_AsyncTransmit` calls for a Sequence transmission of linked Jobs. Write or Read accesses are “User Dependant” and could be skipped when Job is just reading or writing respectively.

Example: Channels ID 0 to 3 belong to Job ID 1 (higher priority), Channels ID 4 to 10 belong to Job ID 2 (Lower priority) which has not an end notification function. These Jobs belong to the same Sequence ID 0

| <i>Sequence</i> | <i>Job</i> | <i>Channel</i> |
|-----------------|------------|----------------|
| ID0 | ID1 | ID0...ID3 |
| | ID2 | ID4...ID10 |

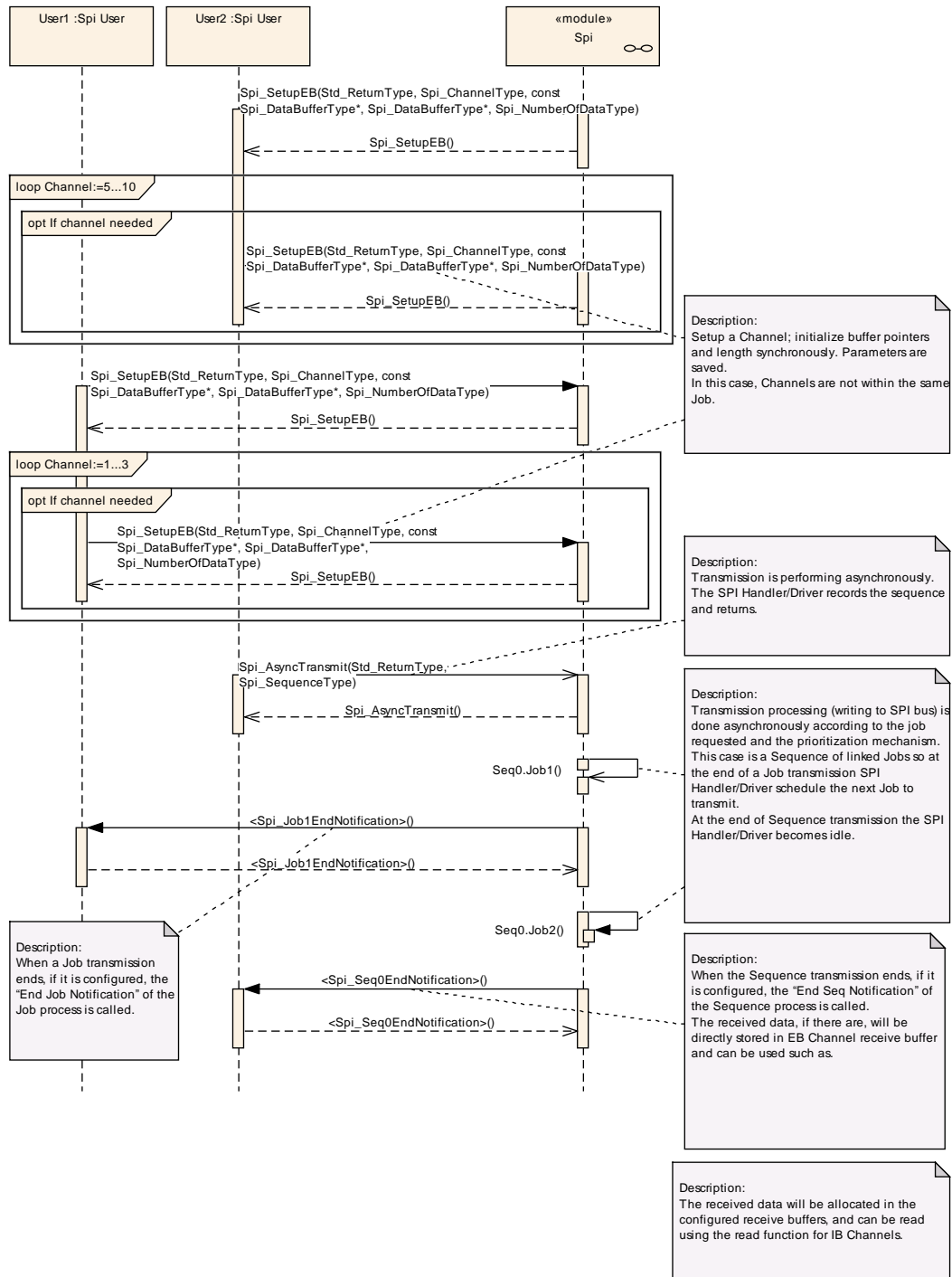

9.4.5 Many Channels, many Jobs and many Sequences

The following sequence diagram shows an example of `Spi_SetupEB` / `Spi_AsyncTransmit` calls for Sequences transmission. Write or Read accesses are “User Dependant” and could be skipped when Job is just reading or writing respectively.

Example: Channels ID 0 to 3 belong to Job ID 1 (high priority 2), Channels ID 4 to 10 belong to Job ID 2 (Low priority 1) which has not an end notification function. These Jobs belong to the same Sequence ID 0 which is configured as interruptible. Channels ID 11 to 13 belong to Job ID 0 (higher priority 3) which belongs to Sequence ID 1 which is configured as not interruptible.

| Sequence | | Job | | Channel |
|-----------------|----------------------|-------------|-----------------|----------------|
| Name | Interruptible | Name | Priority | |
| ID0 | Yes | ID1 | 2 | ID0...ID3 |
| | | ID2 | 1 | ID4...ID10 |
| ID1 | No | ID0 | 3 | ID11...ID13 |

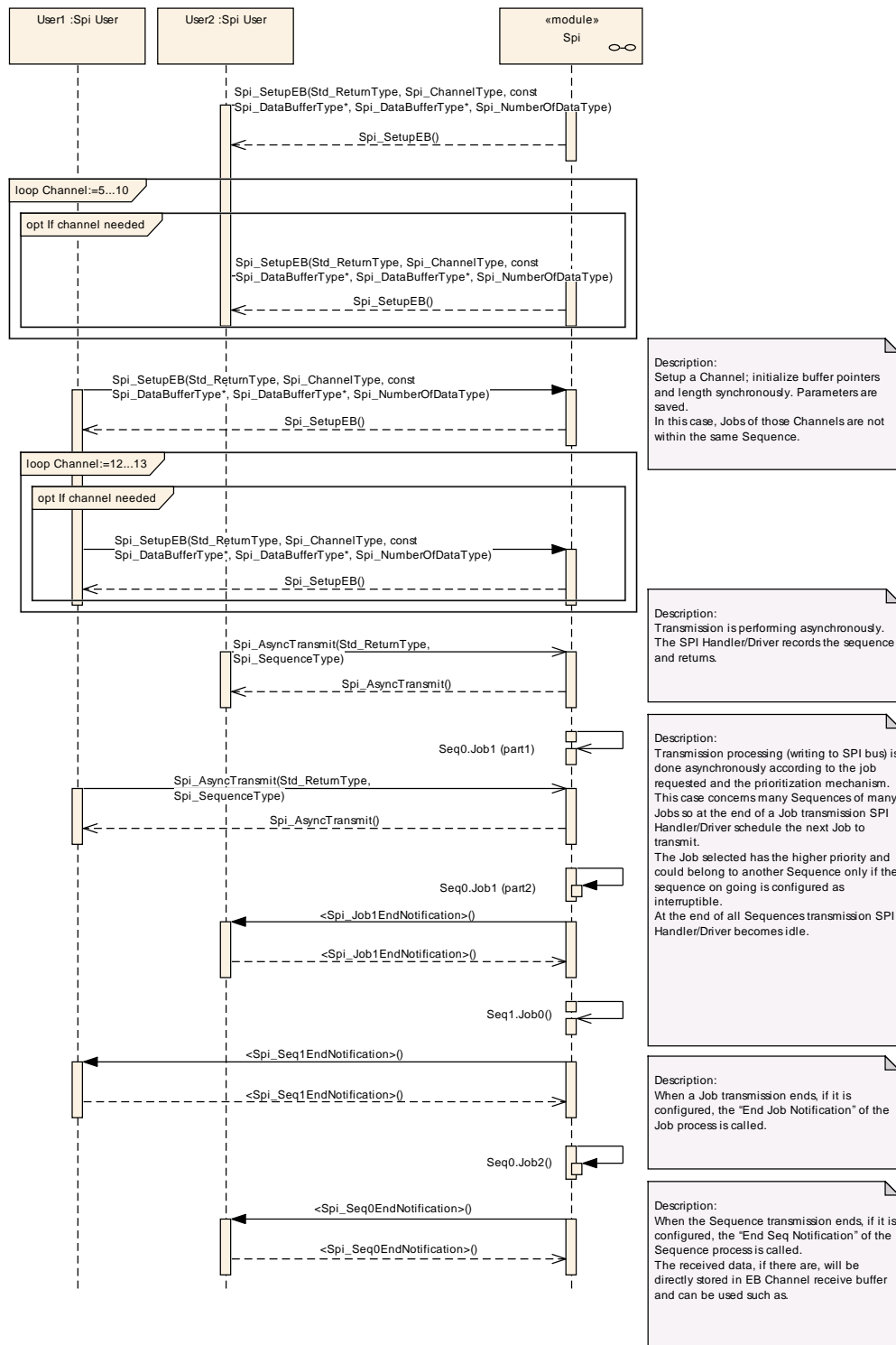

9.5 Mixed Jobs Transmission

All kind of mixed Jobs transmission is possible according to the Channels configuration and the priority requirement inside Sequences.

The user knows which Channels are in use. Then, according to the types of these Channels, the appropriate methods shall be called.

9.6 LEVEL 0 SyncTransmit diagrams

9.6.1 Write/SyncTransmit/Read (IB): Many Channels, many Jobs and one Sequence

The following sequence diagram shows an example of Spi_WriteIB / Spi_SyncTransmit / Spi_ReadIB calls for a Sequence transmission of linked Jobs. Write or Read steps could be skipped when Jobs are just reading or writing respectively.

Example: Channels ID 0 to 3 belong to Job ID 1 (higher priority), Channels ID 4 to 10 belong to Job ID 2 (Lower priority). These Jobs belong to the same Sequence ID 0

| Sequence | Job | | Channel |
|----------|------|----------|------------|
| | Name | Priority | |
| ID0 | ID1 | High | ID0...ID3 |
| | ID2 | Low | ID4...ID10 |

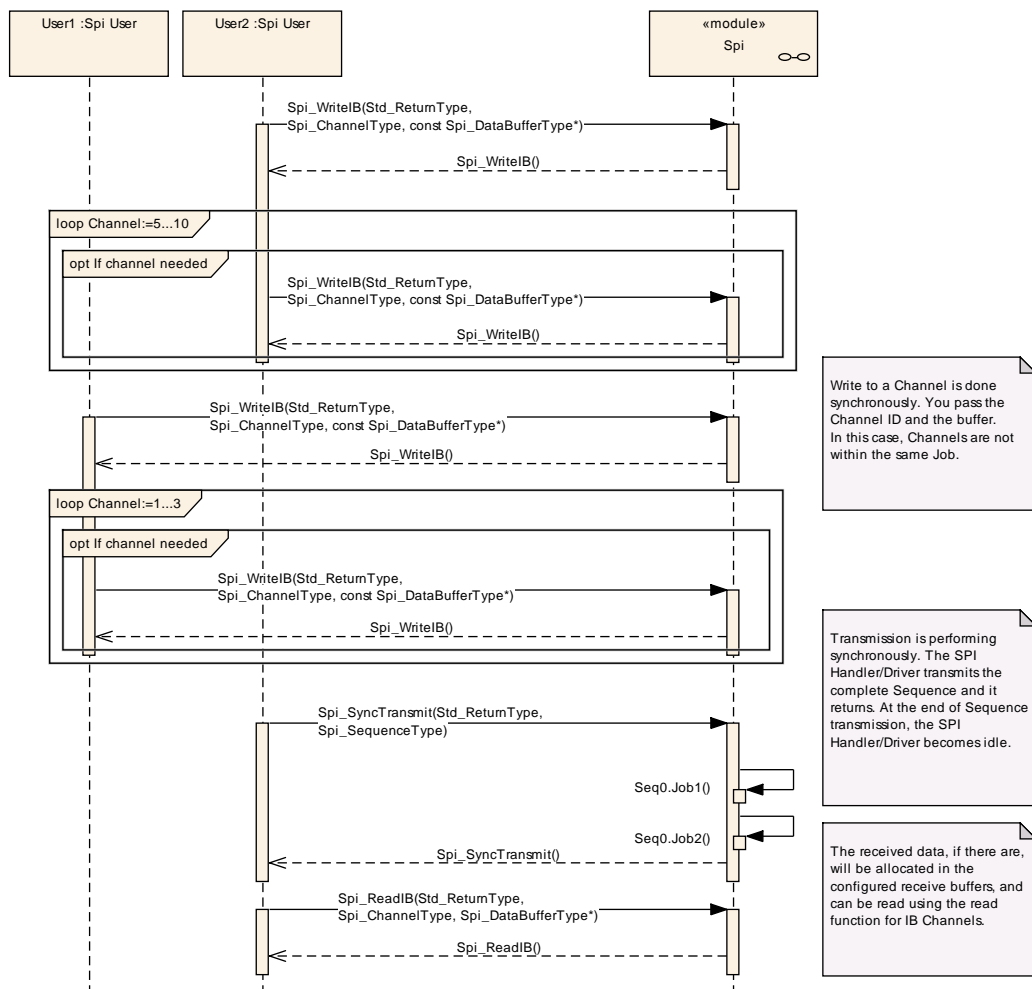

9.6.2 Setup/SyncTransmit (EB): Many Channels, many Jobs and one Sequence

The following sequence diagram shows an example of `Spi_SetupEB` / `Spi_SyncTransmit` calls for a Sequence transmission of linked Jobs. Write or Read accesses are “User Dependant” and could be skipped when Job is just reading or writing respectively.

Example: Channels ID 0 to 3 belong to Job ID 1 (higher priority), Channels ID 4 to 10 belong to Job ID 2 (Lower priority). These Jobs belong to the same Sequence ID 0

| Sequence | Job | Channel |
|----------|-----|------------|
| ID0 | ID1 | ID0...ID3 |
| | ID2 | ID4...ID10 |

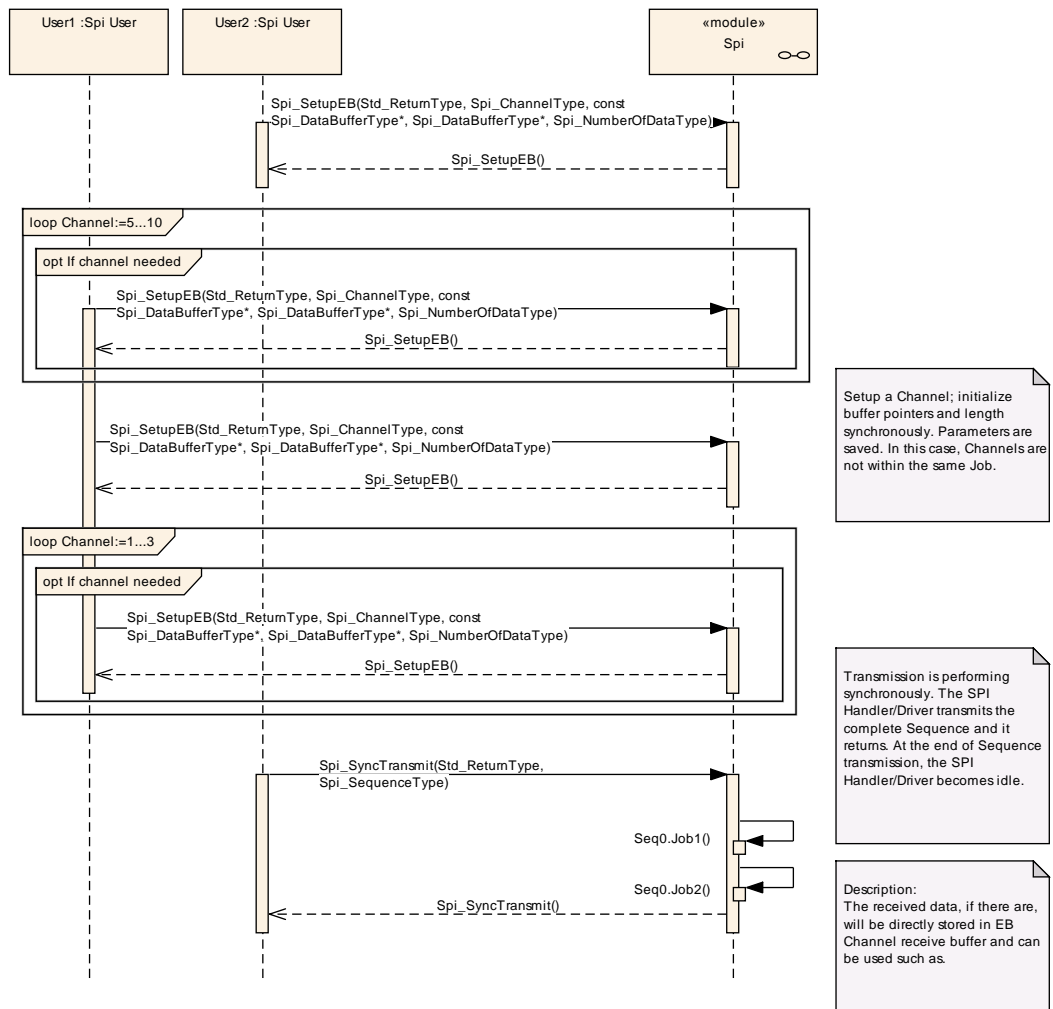

10 Configuration specification

10.1 How to read this chapter

For details refer to the chapter 10.1 “Introduction to configuration specification” in *SWS_BSWGeneral*.

10.2 Containers and configuration parameters

The following chapters summarize all configuration parameters. The detailed meanings of the parameters are described in Chapter 7 and Chapter 8. Further hardware / implementation specific parameters can be added if necessary.

10.2.1 Spi

| | |
|-----------------------------------|--|
| SWS Item | ECUC_Spi_00103 : |
| Module Name | <i>Spi</i> |
| Module Description | Configuration of the Spi (Serial Peripheral Interface) module. |
| Post-Build Variant Support | true |
| Supported Config Variants | VARIANT-LINK-TIME, VARIANT-POST-BUILD, VARIANT-PRE-COMPILE |

Included Containers

| Container Name | Multiplicity | Scope / Dependency |
|--------------------------|--------------|--|
| SpiDemEventParameterRefs | 0..1 | Container for the references to DemEventParameter elements which shall be invoked using the API Dem_SetEventStatus in case the corresponding error occurs. The EventId is taken from the referenced DemEventParameter's DemEventId symbolic value. The standardized errors are provided in this container and can be extended by vendor-specific error references. |
| SpiDriver | 1 | This container contains the configuration parameters and sub containers of the AUTOSAR Spi module. |
| SpiGeneral | 1 | General configuration settings for SPI-Handler |
| SpiPublishedInformation | 1 | Container holding all SPI specific published information parameters |

10.2.2 SpiDemEventParameterRefs

| | |
|---------------------------------|--|
| SWS Item | ECUC_Spi_00240 : |
| Container Name | SpiDemEventParameterRefs |
| Description | Container for the references to DemEventParameter elements which shall be invoked using the API Dem_SetEventStatus in case the corresponding error occurs. The EventId is taken from the referenced DemEventParameter's DemEventId symbolic value. The standardized errors are provided in this container and can be extended by vendor-specific error references. |
| Configuration Parameters | |

| | |
|-------------------------|---|
| SWS Item | ECUC_Spi_00241 : |
| Name | SPI_E_HARDWARE_ERROR |
| Parent Container | SpiDemEventParameterRefs |
| Description | Reference to configured DEM event to report "Hardware failure". If the reference is not configured the error shall not be reported. |
| Multiplicity | 0..1 |
| Type | Symbolic name reference to [DemEventParameter] |

| | | | |
|---|-------------------------|----|--------------|
| Post-Build Variant Multiplicity | false | | |
| Post-Build Variant Value | false | | |
| Multiplicity Configuration Class | Pre-compile time | X | All Variants |
| | Link time | -- | |
| | Post-build time | -- | |
| Value Configuration Class | Pre-compile time | X | All Variants |
| | Link time | -- | |
| | Post-build time | -- | |
| Scope / Dependency | scope: local | | |

No Included Containers

10.2.3 SpiGeneral

| | | | |
|---------------------------------|--|--|--|
| SWS Item | ECUC_Spi_00225 : | | |
| Container Name | SpiGeneral | | |
| Description | General configuration settings for SPI-Handler | | |
| Configuration Parameters | | | |

| | | | |
|----------------------------------|---|----|--------------|
| SWS Item | ECUC_Spi_00226 : | | |
| Name | SpiCancelApi | | |
| Parent Container | SpiGeneral | | |
| Description | Switches the Spi_Cancel function ON or OFF. | | |
| Multiplicity | 1 | | |
| Type | EcucBooleanParamDef | | |
| Default value | -- | | |
| Post-Build Variant Value | false | | |
| Value Configuration Class | Pre-compile time | X | All Variants |
| | Link time | -- | |
| | Post-build time | -- | |
| Scope / Dependency | scope: local | | |

| | | | |
|----------------------------------|---|----|--------------|
| SWS Item | ECUC_Spi_00227 : | | |
| Name | SpiChannelBuffersAllowed | | |
| Parent Container | SpiGeneral | | |
| Description | Selects the SPI Handler/Driver Channel Buffers usage allowed and delivered. IB = 0; EB = 1; IB/EB = 2; | | |
| Multiplicity | 1 | | |
| Type | EcucIntegerParamDef | | |
| Range | 0 .. 2 | | |
| Default value | -- | | |
| Post-Build Variant Value | false | | |
| Value Configuration Class | Pre-compile time | X | All Variants |
| | Link time | -- | |
| | Post-build time | -- | |
| Scope / Dependency | scope: local | | |

| | | | |
|-------------------------|--|--|--|
| SWS Item | ECUC_Spi_00228 : | | |
| Name | SpiDevErrorDetect | | |
| Parent Container | SpiGeneral | | |
| Description | Switches the development error detection and notification on or off. | | |

| | | | |
|----------------------------------|--|----|--------------|
| | <ul style="list-style-type: none"> true: detection and notification is enabled. false: detection and notification is disabled. | | |
| Multiplicity | 1 | | |
| Type | EcucBooleanParamDef | | |
| Default value | false | | |
| Post-Build Variant Value | false | | |
| Value Configuration Class | Pre-compile time | X | All Variants |
| | Link time | -- | |
| | Post-build time | -- | |
| Scope / Dependency | scope: local | | |

| | | | |
|----------------------------------|--|----|--------------|
| SWS Item | ECUC_Spi_00229 : | | |
| Name | SpiHwStatusApi | | |
| Parent Container | SpiGeneral | | |
| Description | Switches the Spi_GetHWUnitStatus function ON or OFF. | | |
| Multiplicity | 1 | | |
| Type | EcucBooleanParamDef | | |
| Default value | -- | | |
| Post-Build Variant Value | false | | |
| Value Configuration Class | Pre-compile time | X | All Variants |
| | Link time | -- | |
| | Post-build time | -- | |
| Scope / Dependency | scope: local | | |

| | | | |
|----------------------------------|--|----|--------------|
| SWS Item | ECUC_Spi_00230 : | | |
| Name | SpiInterruptibleSeqAllowed | | |
| Parent Container | SpiGeneral | | |
| Description | Switches the Interruptible Sequences handling functionality ON or OFF. | | |
| Multiplicity | 1 | | |
| Type | EcucBooleanParamDef | | |
| Default value | -- | | |
| Post-Build Variant Value | false | | |
| Value Configuration Class | Pre-compile time | X | All Variants |
| | Link time | -- | |
| | Post-build time | -- | |
| Scope / Dependency | scope: local dependency: This parameter depends on SPI_LEVEL_DELIVERED value. It is only used for SPI_LEVEL_DELIVERED configured to 1 or 2. | | |

| | | | |
|----------------------------------|---|----|--------------|
| SWS Item | ECUC_Spi_00231 : | | |
| Name | SpiLevelDelivered | | |
| Parent Container | SpiGeneral | | |
| Description | Selects the SPI Handler/Driver level of scalable functionality that is available and delivered. | | |
| Multiplicity | 1 | | |
| Type | EcucIntegerParamDef | | |
| Range | 0 .. 2 | | |
| Default value | -- | | |
| Post-Build Variant Value | false | | |
| Value Configuration Class | Pre-compile time | X | All Variants |
| | Link time | -- | |
| | Post-build time | -- | |

| | | | |
|---|---|----|--------------|
| Scope / Dependency | scope: local | | |
| SWS Item | ECUC_Spi_00242 : | | |
| Name | SpiMainFunctionPeriod | | |
| Parent Container | SpiGeneral | | |
| Description | This parameter defines the cycle time of the function Spi_MainFunction_Handling in seconds. The parameter is not used by the driver it self, but it is used by upper layer. | | |
| Multiplicity | 0..1 | | |
| Type | EcucFloatParamDef | | |
| Range |]0 .. INF[| | |
| Default value | 0.01 | | |
| Post-Build Variant Multiplicity | false | | |
| Post-Build Variant Value | false | | |
| Multiplicity Configuration Class | Pre-compile time | X | All Variants |
| | Link time | -- | |
| | Post-build time | -- | |
| Value Configuration Class | Pre-compile time | X | All Variants |
| | Link time | -- | |
| | Post-build time | -- | |
| Scope / Dependency | scope: local | | |

| | | | |
|----------------------------------|--|----|--------------|
| SWS Item | ECUC_Spi_00237 : | | |
| Name | SpiSupportConcurrentSyncTransmit | | |
| Parent Container | SpiGeneral | | |
| Description | Specifies whether concurrent Spi_SyncTransmit() calls for different sequences shall be configurable. | | |
| Multiplicity | 1 | | |
| Type | EcucBooleanParamDef | | |
| Default value | -- | | |
| Post-Build Variant Value | false | | |
| Value Configuration Class | Pre-compile time | X | All Variants |
| | Link time | -- | |
| | Post-build time | -- | |
| Scope / Dependency | scope: local | | |

| | | | |
|--|---|---|--------------|
| SWS Item | ECUC_Spi_00243 : | | |
| Name | SpiUserCallbackHeaderFile | | |
| Parent Container | SpiGeneral | | |
| Description | Header file name which will be included by the Spi. The value of this parameter shall be used as h-char-sequence or q-char-sequence according to ISO C90 section 6.10.2 "source file inclusion". The parameter value MUST NOT represent a path, since ISO C90 does not specify how such a path is treated (i.e., this is implementation defined (and additionally depends on the operating system and the underlying file system)). | | |
| Multiplicity | 0..* | | |
| Type | EcucStringParamDef | | |
| Default value | -- | | |
| maxLength | -- | | |
| minLength | -- | | |
| regularExpression | -- | | |
| Post-Build Variant Multiplicity | false | | |
| Post-Build Variant Value | false | | |
| Multiplicity Configuration | Pre-compile time | X | All Variants |

| | | | |
|----------------------------------|-------------------------|----|--------------|
| Class | Link time | -- | |
| | Post-build time | -- | |
| Value Configuration Class | Pre-compile time | X | All Variants |
| | Link time | -- | |
| | Post-build time | -- | |
| Scope / Dependency | scope: local | | |

| | | | |
|----------------------------------|---|----|--------------|
| SWS Item | ECUC_Spi_00232 : | | |
| Name | SpiVersionInfoApi | | |
| Parent Container | SpiGeneral | | |
| Description | Switches the Spi_GetVersionInfo function ON or OFF. | | |
| Multiplicity | 1 | | |
| Type | EcucBooleanParamDef | | |
| Default value | false | | |
| Post-Build Variant Value | false | | |
| Value Configuration Class | Pre-compile time | X | All Variants |
| | Link time | -- | |
| | Post-build time | -- | |
| Scope / Dependency | scope: local | | |

No Included Containers

10.2.4 SpiSequence

| | | | |
|---------------------------------|---|--|--|
| SWS Item | ECUC_Spi_00106 : | | |
| Container Name | SpiSequence | | |
| Description | All data needed to configure one SPI-sequence | | |
| Configuration Parameters | | | |

| | | | |
|----------------------------------|---|---|---------------------|
| SWS Item | ECUC_Spi_00222 : | | |
| Name | SpiInterruptibleSequence | | |
| Parent Container | SpiSequence | | |
| Description | This parameter allows or not this Sequence to be suspended by another one. | | |
| Multiplicity | 1 | | |
| Type | EcucBooleanParamDef | | |
| Default value | -- | | |
| Post-Build Variant Value | true | | |
| Value Configuration Class | Pre-compile time | X | VARIANT-PRE-COMPILE |
| | Link time | X | VARIANT-LINK-TIME |
| | Post-build time | X | VARIANT-POST-BUILD |
| Scope / Dependency | scope: local dependency: This SPI_INTERRUPTIBLE_SEQ_ALLOWED parameter as to be configured as ON. | | |

| | | | |
|-------------------------|---|--|--|
| SWS Item | ECUC_Spi_00223 : | | |
| Name | SpiSeqEndNotification | | |
| Parent Container | SpiSequence | | |
| Description | This parameter is a reference to a notification function. | | |
| Multiplicity | 0..1 | | |
| Type | EcucFunctionNameDef | | |
| Default value | -- | | |
| maxLength | -- | | |
| minLength | -- | | |

| | | | |
|---|-------------------------|---|---------------------|
| regularExpression | -- | | |
| Post-Build Variant Multiplicity | true | | |
| Post-Build Variant Value | true | | |
| Multiplicity Configuration Class | Pre-compile time | X | VARIANT-PRE-COMPILE |
| | Link time | X | VARIANT-LINK-TIME |
| | Post-build time | X | VARIANT-POST-BUILD |
| Value Configuration Class | Pre-compile time | X | VARIANT-PRE-COMPILE |
| | Link time | X | VARIANT-LINK-TIME |
| | Post-build time | X | VARIANT-POST-BUILD |
| Scope / Dependency | scope: local | | |

| | | | |
|----------------------------------|--|----|--------------|
| SWS Item | ECUC_Spi_00224 : | | |
| Name | SpiSequenceId | | |
| Parent Container | SpiSequence | | |
| Description | SPI Sequence ID, used as parameter in SPI API functions. | | |
| Multiplicity | 1 | | |
| Type | EcucIntegerParamDef (Symbolic Name generated for this parameter) | | |
| Range | 0 .. 255 | | |
| Default value | -- | | |
| Post-Build Variant Value | false | | |
| Value Configuration Class | Pre-compile time | X | All Variants |
| | Link time | -- | |
| | Post-build time | -- | |
| Scope / Dependency | scope: ECU | | |

| | | | |
|---|--|---|---------------------|
| SWS Item | ECUC_Spi_00221 : | | |
| Name | SpiJobAssignment | | |
| Parent Container | SpiSequence | | |
| Description | A sequence references several jobs, which are executed during a communication sequence | | |
| Multiplicity | 1..* | | |
| Type | Reference to [SpiJob] | | |
| Post-Build Variant Multiplicity | true | | |
| Post-Build Variant Value | true | | |
| Multiplicity Configuration Class | Pre-compile time | X | VARIANT-PRE-COMPILE |
| | Link time | X | VARIANT-LINK-TIME |
| | Post-build time | X | VARIANT-POST-BUILD |
| Value Configuration Class | Pre-compile time | X | VARIANT-PRE-COMPILE |
| | Link time | X | VARIANT-LINK-TIME |
| | Post-build time | X | VARIANT-POST-BUILD |
| Scope / Dependency | scope: local | | |

No Included Containers

10.2.5 SpiChannel

| | | | |
|---------------------------------|--|--|--|
| SWS Item | ECUC_Spi_00104 : | | |
| Container Name | SpiChannel | | |
| Description | All data needed to configure one SPI-channel | | |
| Configuration Parameters | | | |

| | | | |
|-----------------|-------------------------|--|--|
| SWS Item | ECUC_Spi_00200 : | | |
| Name | SpiChannelId | | |

| | | | |
|----------------------------------|--|----|--------------|
| Parent Container | SpiChannel | | |
| Description | SPI Channel ID, used as parameter in SPI API functions. | | |
| Multiplicity | 1 | | |
| Type | EcucIntegerParamDef (Symbolic Name generated for this parameter) | | |
| Range | 0 .. 255 | | |
| Default value | -- | | |
| Post-Build Variant Value | false | | |
| Value Configuration Class | Pre-compile time | X | All Variants |
| | Link time | -- | |
| | Post-build time | -- | |
| Scope / Dependency | scope: local | | |

| | | | |
|----------------------------------|---|-----------------|---------------------|
| SWS Item | ECUC_Spi_00201 : | | |
| Name | SpiChannelType | | |
| Parent Container | SpiChannel | | |
| Description | Buffer usage with EB/IB channel. | | |
| Multiplicity | 1 | | |
| Type | EcucEnumerationParamDef | | |
| Range | EB | External Buffer | |
| | IB | Internal Buffer | |
| Post-Build Variant Value | true | | |
| Value Configuration Class | Pre-compile time | X | VARIANT-PRE-COMPILE |
| | Link time | X | VARIANT-LINK-TIME |
| | Post-build time | X | VARIANT-POST-BUILD |
| Scope / Dependency | scope: local dependency: SPI_CHANNEL_BUFFERS_ALLOWED | | |

| | | | |
|----------------------------------|---|---|---------------------|
| SWS Item | ECUC_Spi_00202 : | | |
| Name | SpiDataWidth | | |
| Parent Container | SpiChannel | | |
| Description | This parameter is the width of a transmitted data unit. | | |
| Multiplicity | 1 | | |
| Type | EcucIntegerParamDef | | |
| Range | 1 .. 32 | | |
| Default value | -- | | |
| Post-Build Variant Value | true | | |
| Value Configuration Class | Pre-compile time | X | VARIANT-PRE-COMPILE |
| | Link time | X | VARIANT-LINK-TIME |
| | Post-build time | X | VARIANT-POST-BUILD |
| Scope / Dependency | scope: local | | |

| | | | |
|--|---|---|---------------------|
| SWS Item | ECUC_Spi_00203 : | | |
| Name | SpiDefaultData | | |
| Parent Container | SpiChannel | | |
| Description | The default data to be transmitted when (for internal buffer or external buffer) the pointer passed to Spi_WriteIB (for internal buffer) or to Spi_SetupEB (for external buffer) is NULL. | | |
| Multiplicity | 0..1 | | |
| Type | EcucIntegerParamDef | | |
| Range | 0 .. 4294967295 | | |
| Default value | -- | | |
| Post-Build Variant Multiplicity | true | | |
| Post-Build Variant Value | true | | |
| Multiplicity Configuration | Pre-compile time | X | VARIANT-PRE-COMPILE |

| | | | |
|----------------------------------|-------------------------|---|---------------------|
| Class | Link time | X | VARIANT-LINK-TIME |
| | Post-build time | X | VARIANT-POST-BUILD |
| Value Configuration Class | Pre-compile time | X | VARIANT-PRE-COMPILE |
| | Link time | X | VARIANT-LINK-TIME |
| | Post-build time | X | VARIANT-POST-BUILD |
| Scope / Dependency | scope: local | | |

| | | | |
|----------------------------------|--|---|---------------------|
| SWS Item | ECUC_Spi_00204 : | | |
| Name | SpiEbMaxLength | | |
| Parent Container | SpiChannel | | |
| Description | This parameter contains the maximum size (number of data elements) of data buffers in case of EB Channels and only. | | |
| Multiplicity | 1 | | |
| Type | EcucIntegerParamDef | | |
| Range | 0 .. 65535 | | |
| Default value | -- | | |
| Post-Build Variant Value | true | | |
| Value Configuration Class | Pre-compile time | X | VARIANT-PRE-COMPILE |
| | Link time | X | VARIANT-LINK-TIME |
| | Post-build time | X | VARIANT-POST-BUILD |
| Scope / Dependency | scope: local dependency: The SPI_CHANNEL_TYPE parameter has to be configured as EB for this Channel. The SPI_CHANNEL_BUFFERS_ALLOWED parameter has to be configured as 1 or 2. | | |

| | | | |
|----------------------------------|---|---|---------------------|
| SWS Item | ECUC_Spi_00205 : | | |
| Name | SpilbNBuffers | | |
| Parent Container | SpiChannel | | |
| Description | This parameter contains the maximum number of data buffers in case of IB Channels and only. | | |
| Multiplicity | 1 | | |
| Type | EcucIntegerParamDef | | |
| Range | 0 .. 65535 | | |
| Default value | -- | | |
| Post-Build Variant Value | true | | |
| Value Configuration Class | Pre-compile time | X | VARIANT-PRE-COMPILE |
| | Link time | X | VARIANT-LINK-TIME |
| | Post-build time | X | VARIANT-POST-BUILD |
| Scope / Dependency | scope: local dependency: The SPI_CHANNEL_TYPE parameter has to be configured as IB for this Channel. The SPI_CHANNEL_BUFFERS_ALLOWED parameter has to be configured as 0 or 2. | | |

| | | | |
|---------------------------------|---|--|--|
| SWS Item | ECUC_Spi_00206 : | | |
| Name | SpiTransferStart | | |
| Parent Container | SpiChannel | | |
| Description | This parameter defines the first starting bit for transmission. | | |
| Multiplicity | 1 | | |
| Type | EcucEnumerationParamDef | | |
| Range | LSB | | Transmission starts with the Least Significant Bit first |
| | MSB | | Transmission starts with the Most Significant Bit first |
| Post-Build Variant Value | true | | |

| | | | |
|----------------------------------|-------------------------|---|---------------------|
| Value Configuration Class | Pre-compile time | X | VARIANT-PRE-COMPILE |
| | Link time | X | VARIANT-LINK-TIME |
| | Post-build time | X | VARIANT-POST-BUILD |
| Scope / Dependency | scope: local | | |

No Included Containers

10.2.6 SpiChannelList

| | | | |
|---------------------------------|--|--|--|
| SWS Item | ECUC_Spi_00233 : | | |
| Container Name | SpiChannelList | | |
| Description | References to SPI channels and their order within the Job. | | |
| Configuration Parameters | | | |

| | | | |
|----------------------------------|--|---|---------------------|
| SWS Item | ECUC_Spi_00234 : | | |
| Name | SpiChannelIndex | | |
| Parent Container | SpiChannelList | | |
| Description | This parameter specifies the order of Channels within the Job. | | |
| Multiplicity | 1 | | |
| Type | EcucIntegerParamDef | | |
| Range | 0 .. 255 | | |
| Default value | -- | | |
| Post-Build Variant Value | true | | |
| Value Configuration Class | Pre-compile time | X | VARIANT-PRE-COMPILE |
| | Link time | X | VARIANT-LINK-TIME |
| | Post-build time | X | VARIANT-POST-BUILD |
| Scope / Dependency | scope: local | | |

| | | | |
|----------------------------------|-----------------------------------|---|---------------------|
| SWS Item | ECUC_Spi_00215 : | | |
| Name | SpiChannelAssignment | | |
| Parent Container | SpiChannelList | | |
| Description | A job reference to a SPI channel. | | |
| Multiplicity | 1 | | |
| Type | Reference to [SpiChannel] | | |
| Post-Build Variant Value | true | | |
| Value Configuration Class | Pre-compile time | X | VARIANT-PRE-COMPILE |
| | Link time | X | VARIANT-LINK-TIME |
| | Post-build time | X | VARIANT-POST-BUILD |
| Scope / Dependency | scope: local | | |

No Included Containers

10.2.7 SpiJob

| | | | |
|---------------------------------|--|--|--|
| SWS Item | ECUC_Spi_00105 : | | |
| Container Name | SpiJob | | |
| Description | All data needed to configure one SPI-Job, amongst others the connection between the internal SPI unit and the special settings for an external device is done. | | |
| Configuration Parameters | | | |

| | | | |
|-------------------------|------------------------------------|--|--|
| SWS Item | ECUC_Spi_00238 : (Obsolete) | | |
| Name | SpiHwUnitSynchronous | | |
| Parent Container | SpiJob | | |

| | | | |
|---|---|----|---------------------|
| Description | If SpiHwUnitSynchronous is set to "SYNCHRONOUS", the SpiJob uses its containing SpiDriver in a synchronous manner. If it is set to "ASYNCHRONOUS", it uses the driver in an asynchronous way. If the parameter is not set, the SpiChannel uses the driver also in an asynchronous way. Tags: atp.Status=obsolete | | |
| Multiplicity | 0..1 | | |
| Type | EcucEnumerationParamDef | | |
| Range | ASYNCHRONOUS | -- | |
| | SYNCHRONOUS | -- | |
| Post-Build Variant Multiplicity | true | | |
| Post-Build Variant Value | true | | |
| Multiplicity Configuration Class | Pre-compile time | X | VARIANT-PRE-COMPILE |
| | Link time | X | VARIANT-LINK-TIME |
| | Post-build time | X | VARIANT-POST-BUILD |
| Value Configuration Class | Pre-compile time | X | VARIANT-PRE-COMPILE |
| | Link time | X | VARIANT-LINK-TIME |
| | Post-build time | X | VARIANT-POST-BUILD |
| Scope / Dependency | scope: local | | |

| | | | |
|---|---|---|---------------------|
| SWS Item | ECUC_Spi_00218 : | | |
| Name | SpiJobEndNotification | | |
| Parent Container | SpiJob | | |
| Description | This parameter is a reference to a notification function. | | |
| Multiplicity | 0..1 | | |
| Type | EcucFunctionNameDef | | |
| Default value | -- | | |
| maxLength | -- | | |
| minLength | -- | | |
| regularExpression | -- | | |
| Post-Build Variant Multiplicity | true | | |
| Post-Build Variant Value | true | | |
| Multiplicity Configuration Class | Pre-compile time | X | VARIANT-PRE-COMPILE |
| | Link time | X | VARIANT-LINK-TIME |
| | Post-build time | X | VARIANT-POST-BUILD |
| Value Configuration Class | Pre-compile time | X | VARIANT-PRE-COMPILE |
| | Link time | X | VARIANT-LINK-TIME |
| | Post-build time | X | VARIANT-POST-BUILD |
| Scope / Dependency | scope: local | | |

| | | | |
|----------------------------------|--|----|--------------|
| SWS Item | ECUC_Spi_00219 : | | |
| Name | SpiJobId | | |
| Parent Container | SpiJob | | |
| Description | SPI Job ID, used as parameter in SPI API functions. | | |
| Multiplicity | 1 | | |
| Type | EcucIntegerParamDef (Symbolic Name generated for this parameter) | | |
| Range | 0 .. 65535 | | |
| Default value | -- | | |
| Post-Build Variant Value | false | | |
| Value Configuration Class | Pre-compile time | X | All Variants |
| | Link time | -- | |
| | Post-build time | -- | |

| | |
|---------------------------|--------------|
| Scope / Dependency | scope: local |
|---------------------------|--------------|

| | | | |
|----------------------------------|--|---|---------------------|
| SWS Item | ECUC_Spi_00220 : | | |
| Name | SpiJobPriority | | |
| Parent Container | SpiJob | | |
| Description | Priority set accordingly to SPI093: 0, lowest, 3, highest priority | | |
| Multiplicity | 1 | | |
| Type | EcucIntegerParamDef | | |
| Range | 0 .. 3 | | |
| Default value | -- | | |
| Post-Build Variant Value | true | | |
| Value Configuration Class | Pre-compile time | X | VARIANT-PRE-COMPILE |
| | Link time | X | VARIANT-LINK-TIME |
| | Post-build time | X | VARIANT-POST-BUILD |
| Scope / Dependency | scope: local | | |

| | | | |
|----------------------------------|---|----|--------------|
| SWS Item | ECUC_Spi_00216 : | | |
| Name | SpiDeviceAssignment | | |
| Parent Container | SpiJob | | |
| Description | Reference to the external device used by this job | | |
| Multiplicity | 1 | | |
| Type | Reference to [SpiExternalDevice] | | |
| Post-Build Variant Value | false | | |
| Value Configuration Class | Pre-compile time | X | All Variants |
| | Link time | -- | |
| | Post-build time | -- | |
| Scope / Dependency | scope: local | | |

| | | |
|----------------------------|---------------------|--|
| Included Containers | | |
| Container Name | Multiplicity | Scope / Dependency |
| SpiChannellist | 1..* | References to SPI channels and their order within the Job. |

10.2.8 SpiExternalDevice

| | | | |
|---------------------------------|--|--|--|
| SWS Item | ECUC_Spi_00207 : | | |
| Container Name | SpiExternalDevice | | |
| Description | The communication settings of an external device. Closely linked to Spi-Job. | | |
| Configuration Parameters | | | |

| | | | |
|----------------------------------|---|---|---------------------|
| SWS Item | ECUC_Spi_00208 : | | |
| Name | SpiBaudrate | | |
| Parent Container | SpiExternalDevice | | |
| Description | This parameter is the communication baudrate - This parameter allows using a range of values, from the point of view of configuration tools, from Hz up to MHz. | | |
| Multiplicity | 1 | | |
| Type | EcucFloatParamDef | | |
| Range | [0 .. INF] | | |
| Default value | -- | | |
| Post-Build Variant Value | true | | |
| Value Configuration Class | Pre-compile time | X | VARIANT-PRE-COMPILE |
| | Link time | X | VARIANT-LINK-TIME |
| | Post-build time | X | VARIANT-POST-BUILD |
| Scope / Dependency | scope: local | | |

| | | | |
|----------------------------------|---|----|--------------|
| SWS Item | ECUC_Spi_00209 : | | |
| Name | SpiCsIdentifier | | |
| Parent Container | SpiExternalDevice | | |
| Description | This parameter is the symbolic name to identify the Chip Select (CS) allocated to this Job. | | |
| Multiplicity | 1 | | |
| Type | EcucStringParamDef (Symbolic Name generated for this parameter) | | |
| Default value | -- | | |
| maxLength | -- | | |
| minLength | -- | | |
| regularExpression | -- | | |
| Post-Build Variant Value | false | | |
| Value Configuration Class | Pre-compile time | X | All Variants |
| | Link time | -- | |
| | Post-build time | -- | |
| Scope / Dependency | scope: local | | |

| | | | |
|----------------------------------|--|----|---------------------|
| SWS Item | ECUC_Spi_00210 : | | |
| Name | SpiCsPolarity | | |
| Parent Container | SpiExternalDevice | | |
| Description | This parameter defines the active polarity of Chip Select. | | |
| Multiplicity | 1 | | |
| Type | EcucEnumerationParamDef | | |
| Range | HIGH | -- | |
| | LOW | -- | |
| Post-Build Variant Value | true | | |
| Value Configuration Class | Pre-compile time | X | VARIANT-PRE-COMPILE |
| | Link time | X | VARIANT-LINK-TIME |
| | Post-build time | X | VARIANT-POST-BUILD |
| Scope / Dependency | scope: local | | |

| | | | |
|---|--|---|---|
| SWS Item | ECUC_Spi_00239 : | | |
| Name | SpiCsSelection | | |
| Parent Container | SpiExternalDevice | | |
| Description | When the Chip select handling is enabled (see SpiEnableCs), then this parameter specifies if the chip select is handled automatically by Peripheral HW engine or via general purpose IO by Spi driver. | | |
| Multiplicity | 0..1 | | |
| Type | EcucEnumerationParamDef | | |
| Range | CS_VIA_GPIO | | chip select handled via gpio by Spi driver. |
| | CS_VIA_PERIPHERAL_ENGINE | | chip select is handled automatically by Peripheral HW engine. |
| Default value | CS_VIA_PERIPHERAL_ENGINE | | |
| Post-Build Variant Multiplicity | true | | |
| Post-Build Variant Value | true | | |
| Multiplicity Configuration Class | Pre-compile time | X | VARIANT-PRE-COMPILE |
| | Link time | X | VARIANT-LINK-TIME |
| | Post-build time | X | VARIANT-POST-BUILD |
| Value Configuration Class | Pre-compile time | X | VARIANT-PRE-COMPILE |
| | Link time | X | VARIANT-LINK-TIME |
| | Post-build time | X | VARIANT-POST-BUILD |

| | |
|---------------------------|---|
| Scope / Dependency | scope: local dependency: SpiEnableCs |
|---------------------------|---|

| | | | |
|----------------------------------|---|----|---------------------|
| SWS Item | ECUC_Spi_00211 : | | |
| Name | SpiDataShiftEdge | | |
| Parent Container | SpiExternalDevice | | |
| Description | This parameter defines the SPI data shift edge. | | |
| Multiplicity | 1 | | |
| Type | EcucEnumerationParamDef | | |
| Range | LEADING | -- | |
| | TRAILING | -- | |
| Post-Build Variant Value | true | | |
| Value Configuration Class | Pre-compile time | X | VARIANT-PRE-COMPILE |
| | Link time | X | VARIANT-LINK-TIME |
| | Post-build time | X | VARIANT-POST-BUILD |
| Scope / Dependency | scope: local | | |

| | | | |
|----------------------------------|--|---|---------------------|
| SWS Item | ECUC_Spi_00212 : | | |
| Name | SpiEnableCs | | |
| Parent Container | SpiExternalDevice | | |
| Description | This parameter enables or not the Chip Select handling functions. If this parameter is enabled then parameter SpiCsSelection further details the type of chip selection. | | |
| Multiplicity | 1 | | |
| Type | EcucBooleanParamDef | | |
| Default value | -- | | |
| Post-Build Variant Value | true | | |
| Value Configuration Class | Pre-compile time | X | VARIANT-PRE-COMPILE |
| | Link time | X | VARIANT-LINK-TIME |
| | Post-build time | X | VARIANT-POST-BUILD |
| Scope / Dependency | scope: local | | |

| | | | |
|----------------------------------|---|----|---------------------|
| SWS Item | ECUC_Spi_00217 : | | |
| Name | SpiHwUnit | | |
| Parent Container | SpiExternalDevice | | |
| Description | This parameter is the symbolic name to identify the HW SPI Hardware microcontroller peripheral allocated to this Job. | | |
| Multiplicity | 1 | | |
| Type | EcucEnumerationParamDef | | |
| Range | CSIB0 | -- | |
| | CSIB1 | -- | |
| | CSIB2 | -- | |
| | CSIB3 | -- | |
| Post-Build Variant Value | true | | |
| Value Configuration Class | Pre-compile time | X | VARIANT-PRE-COMPILE |
| | Link time | X | VARIANT-LINK-TIME |
| | Post-build time | X | VARIANT-POST-BUILD |
| Scope / Dependency | scope: local | | |

| | | | |
|-------------------------|-------------------------|--|--|
| SWS Item | ECUC_Spi_00213 : | | |
| Name | SpiShiftClockIdleLevel | | |
| Parent Container | SpiExternalDevice | | |

| | | | |
|----------------------------------|--|----|---------------------|
| Description | This parameter defines the SPI shift clock idle level. | | |
| Multiplicity | 1 | | |
| Type | EcucEnumerationParamDef | | |
| Range | HIGH | -- | |
| | LOW | -- | |
| Post-Build Variant Value | true | | |
| Value Configuration Class | Pre-compile time | X | VARIANT-PRE-COMPILE |
| | Link time | X | VARIANT-LINK-TIME |
| | Post-build time | X | VARIANT-POST-BUILD |
| Scope / Dependency | scope: local | | |

| | | | |
|----------------------------------|---|---|---------------------|
| SWS Item | ECUC_Spi_00214 : | | |
| Name | SpiTimeClk2Cs | | |
| Parent Container | SpiExternalDevice | | |
| Description | Timing between clock and chip select (in seconds) - This parameter allows to use a range of values from 0 up to 0.0001 seconds. The real configuration-value used in software BSW-SPI is calculated out of this by the generator-tools | | |
| Multiplicity | 1 | | |
| Type | EcucFloatParamDef | | |
| Range | [0 .. 1E-4] | | |
| Default value | -- | | |
| Post-Build Variant Value | true | | |
| Value Configuration Class | Pre-compile time | X | VARIANT-PRE-COMPILE |
| | Link time | X | VARIANT-LINK-TIME |
| | Post-build time | X | VARIANT-POST-BUILD |
| Scope / Dependency | scope: local | | |

No Included Containers

10.2.9 SpiDriver

| | | | |
|---------------------------------|--|--|--|
| SWS Item | ECUC_Spi_00091 : | | |
| Container Name | SpiDriver | | |
| Description | This container contains the configuration parameters and sub containers of the AUTOSAR Spi module. | | |
| Configuration Parameters | | | |

| | | | |
|---|---|---|---------------------|
| SWS Item | ECUC_Spi_00197 : | | |
| Name | SpiMaxChannel | | |
| Parent Container | SpiDriver | | |
| Description | This parameter contains the number of Channels configured. It will be gathered by tools during the configuration stage. | | |
| Multiplicity | 0..1 | | |
| Type | EcucIntegerParamDef | | |
| Range | 0 .. 255 | | |
| Default value | -- | | |
| Post-Build Variant Multiplicity | true | | |
| Post-Build Variant Value | true | | |
| Multiplicity Configuration Class | Pre-compile time | X | VARIANT-PRE-COMPILE |
| | Link time | X | VARIANT-LINK-TIME |
| | Post-build time | X | VARIANT-POST-BUILD |
| Value Configuration Class | Pre-compile time | X | VARIANT-PRE-COMPILE |

| | | | |
|---------------------------|------------------------|---|--------------------|
| | Link time | X | VARIANT-LINK-TIME |
| | Post-build time | X | VARIANT-POST-BUILD |
| Scope / Dependency | scope: local | | |

| | | | |
|---|----------------------------------|---|---------------------|
| SWS Item | ECUC_Spi_00198 : | | |
| Name | SpiMaxJob | | |
| Parent Container | SpiDriver | | |
| Description | Total number of Jobs configured. | | |
| Multiplicity | 0..1 | | |
| Type | EcucIntegerParamDef | | |
| Range | 0 .. 65535 | | |
| Default value | -- | | |
| Post-Build Variant Multiplicity | true | | |
| Post-Build Variant Value | true | | |
| Multiplicity Configuration Class | Pre-compile time | X | VARIANT-PRE-COMPILE |
| | Link time | X | VARIANT-LINK-TIME |
| | Post-build time | X | VARIANT-POST-BUILD |
| Value Configuration Class | Pre-compile time | X | VARIANT-PRE-COMPILE |
| | Link time | X | VARIANT-LINK-TIME |
| | Post-build time | X | VARIANT-POST-BUILD |
| Scope / Dependency | scope: local | | |

| | | | |
|---|---------------------------------------|---|---------------------|
| SWS Item | ECUC_Spi_00199 : | | |
| Name | SpiMaxSequence | | |
| Parent Container | SpiDriver | | |
| Description | Total number of Sequences configured. | | |
| Multiplicity | 0..1 | | |
| Type | EcucIntegerParamDef | | |
| Range | 0 .. 255 | | |
| Default value | -- | | |
| Post-Build Variant Multiplicity | true | | |
| Post-Build Variant Value | true | | |
| Multiplicity Configuration Class | Pre-compile time | X | VARIANT-PRE-COMPILE |
| | Link time | X | VARIANT-LINK-TIME |
| | Post-build time | X | VARIANT-POST-BUILD |
| Value Configuration Class | Pre-compile time | X | VARIANT-PRE-COMPILE |
| | Link time | X | VARIANT-LINK-TIME |
| | Post-build time | X | VARIANT-POST-BUILD |
| Scope / Dependency | scope: local | | |

| Included Containers | | |
|----------------------------|---------------------|--|
| Container Name | Multiplicity | Scope / Dependency |
| SpiChannel | 1..* | All data needed to configure one SPI-channel |
| SpiExternalDevice | 1..* | The communication settings of an external device. Closely linked to SpiJob. |
| SpiJob | 1..* | All data needed to configure one SPI-Job, amongst others the connection between the internal SPI unit and the special settings for an external device is done. |
| SpiSequence | 1..* | All data needed to configure one SPI-sequence |

10.2.10 SpiPublishedInformation

| | | | |
|-----------------------|---|--|--|
| SWS Item | ECUC_Spi_00235 : | | |
| Container Name | SpiPublishedInformation | | |
| Description | Container holding all SPI specific published information parameters | | |

| |
|---------------------------------|
| Configuration Parameters |
|---------------------------------|

| | | | |
|----------------------------------|--|----------------------|--------------|
| SWS Item | ECUC_Spi_00236 : | | |
| Name | SpiMaxHwUnit | | |
| Parent Container | SpiPublishedInformation | | |
| Description | Number of different SPI hardware microcontroller peripherals (units/busses) available and handled by this SPI Handler/Driver module. | | |
| Multiplicity | 1 | | |
| Type | EcucIntegerParamDef | | |
| Range | 0 .. | 18446744073709551615 | |
| Default value | -- | | |
| Post-Build Variant Value | false | | |
| Value Configuration Class | Published Information | X | All Variants |
| Scope / Dependency | scope: local | | |

| |
|-------------------------------|
| No Included Containers |
|-------------------------------|

10.3 Published information

For details refer to the chapter 10.3 “Published Information” in *SWS_BSWGeneral*

10.4 Configuration concept

There is a relationship between the SPI Handler/Driver module and the modules that use it. This relationship is resolved during the configuration stage and the result of it influences the proper API and behaviour between those modules.

The user needs to provide to the SPI Handler/Driver part of the configuration to adapt it to its necessities. The SPI Handler/Driver shall take this configuration and provide the needed tools to the user.

The picture shows the information flow during the configuration of the SPI Handler/Driver. It is shown only for one user, using an External EEPROM Driver as example, but this situation is common to all users of the SPI Handler/Driver. To highlight the situation where more users are affected, several overlapping documents are drawn.

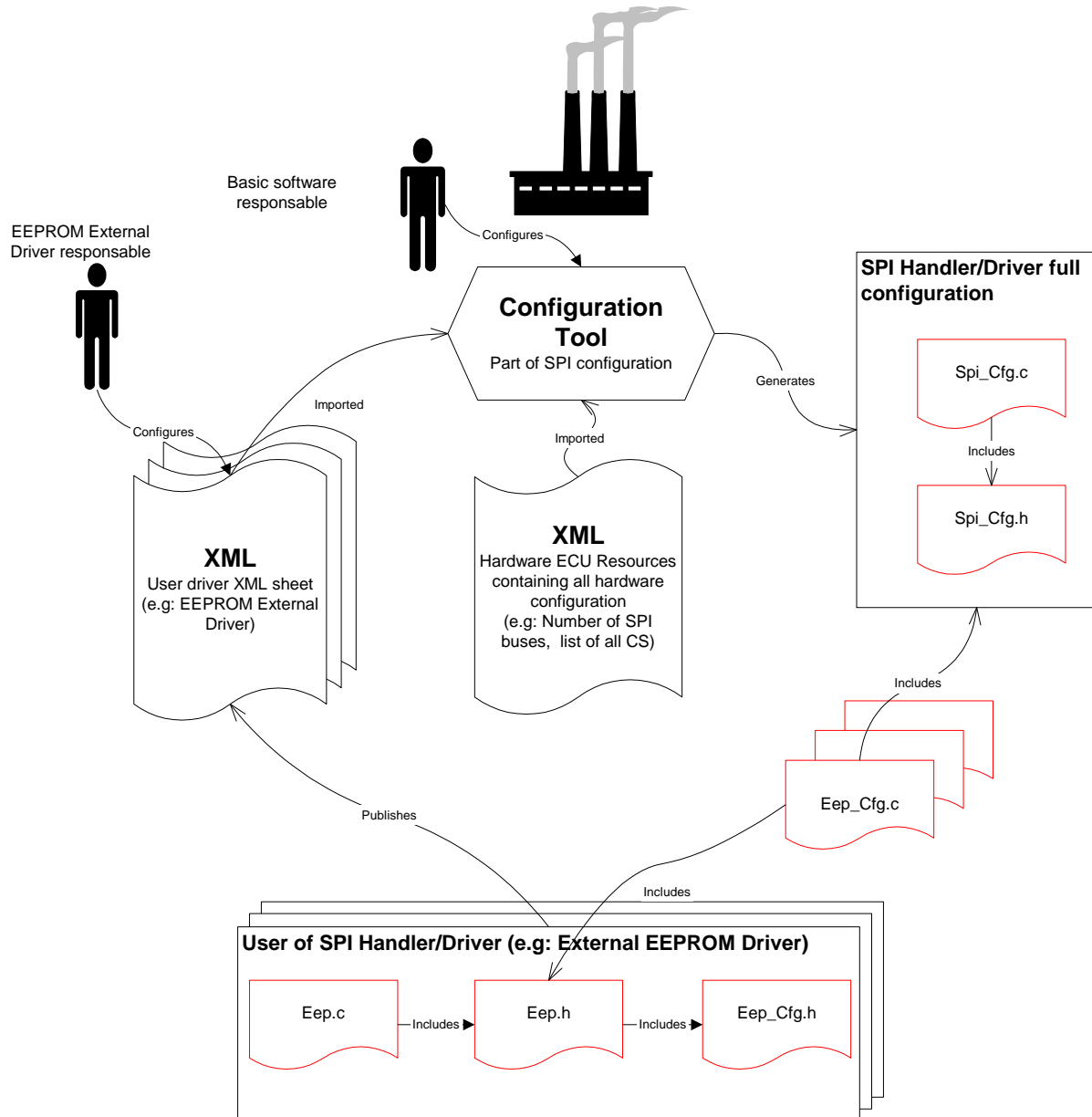

The steps on the diagrams are:

1. The user (External EEPROM Driver) of SPI Handler/Driver edits a XML configuration file. This XML configuration file is the same used by the user to generate its own configuration.
2. For each ECU, a XML HW configuration document contains information which should be used in order to configure some parameters.
3. The “SPI generation tool”. The Generation tool (here is reflected only the part that generates code to SPI usage) shall generate the handles to export and the instance of the configuration sets. In this step the software integrator will provide missing information.
4. SPI instance configuration file. As a result of the generation all the symbolic handlers needed by the user are included in the configuration header file of the SPI Handler/Driver.
5. User gets the symbolic name of handlers. User imports the handle generated to make use of them as requested by its XML configuration file.

11 Not applicable requirements

[SWS_Spi_00999] [These requirements are not applicable to this specification.]
(SRS_BSW_00301, SRS_BSW_00302, SRS_BSW_00306, SRS_BSW_00307,
SRS_BSW_00308, SRS_BSW_00309, SRS_BSW_00312, SRS_BSW_00325,
SRS_BSW_00328, SRS_BSW_00330, SRS_BSW_00331, SRS_BSW_00334,
SRS_BSW_00341, SRS_BSW_00342, SRS_BSW_00343, SRS_BSW_00347,
SRS_BSW_00375, SRS_BSW_00399, SRS_BSW_00400, SRS_BSW_00401,
SRS_BSW_00413, SRS_BSW_00416, SRS_BSW_00417, SRS_BSW_00422,
SRS_BSW_00423, SRS_BSW_00424, SRS_BSW_00426, SRS_BSW_00427,
SRS_BSW_00428, SRS_BSW_00429, SRS_BSW_00432, SRS_BSW_00433,
SRS_BSW_00005, SRS_BSW_00006, SRS_BSW_00009, SRS_BSW_00010,
SRS_BSW_00161, SRS_BSW_00164, SRS_BSW_00168, SRS_BSW_00170,
SRS_BSW_00172, SRS_SPAL_12267, SRS_SPAL_12068, SRS_SPAL_12069,
SRS_SPAL_12063, SRS_SPAL_12129, SRS_SPAL_12067, SRS_SPAL_12077,
SRS_SPAL_12078, SRS_SPAL_12092, SRS_SPAL_12265)

12 Appendix

The table shown on the next page is just an example to help future users (and/or developers) that have to configure software modules to use the SPI Handler/Driver. This table is independent of the `Spi_ConfigType` structure but contains all elements and aggregations like Channels, Jobs and Sequences.

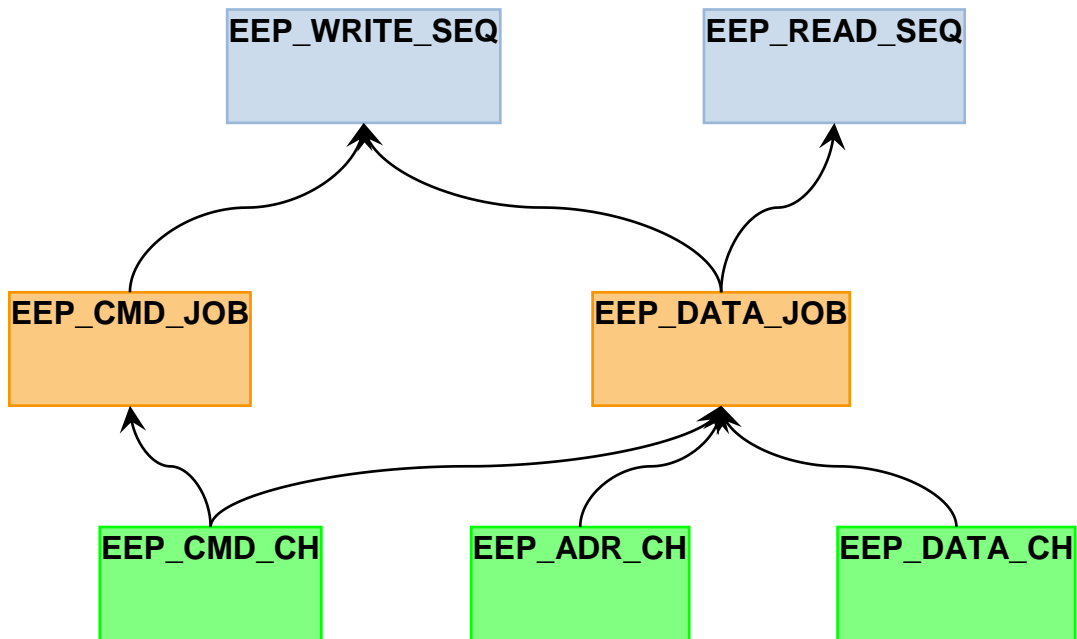

| External EEPROM Write/Read Configuration for SPI Handler/Driver | | | | | | | | |
|---|----|--|---------------|----|--|---------------|----|---|
| Sequences | | | Jobs | | | Channels | | |
| Symbolic Name | ID | Attributes | Symbolic Name | ID | Attributes | Symbolic Name | ID | Attributes |
| EEP_WRITE_SEQ | 0 | 2 (Number of Jobs), {EEP_CMD_JOB, EEP_DATA_JOB} (List of Jobs), Not Interruptible, EEP_vidEndOfWriteSeq | EEP_CMD_JOB | 0 | SPI_BUS_0, CS_EEPROM, CS_ON, CS_LOW, CLK_2MHz, 1 (time in µs), Polarity 180, Falling Edge, 3, EEP_vidEndOfStartWrJob, 1 (Number of Channels) {EEP_CMD_CH} (List of Chan- nels) | EEP_CMD_CH | 0 | EB, 8 bits, 1 data to TxD, MSB First, Default value is 0x00 |
| EEP_READ_SEQ | 1 | 1 (Number of Jobs), {EEP_DATA_JOB} (List of Jobs), Not Interruptible, EEP_vidEndOfReadSeq | EEP_DATA_JOB | 1 | SPI_BUS_0, CS_EEPROM, CS_ON, CS_LOW, CLK_2MHz, 1 (time in µs), Polarity 180, Falling Edge, 2, NULL, 3 (Number of Channels) {EEP_CMD_CH, EEP_ADR_CH, EEP_DATA_CH} (List of Chan- nels) | EEP_ADR_CH | 1 | EB, 16 bits, 1 data to TxD, MSB First, Default value is 0x0000 |
| | | | | | | EEP_DATA_CH | 2 | EB, 8 bits, 32 data to TxD, MSB First, Default value is 0x00 |

