

Document Title	Specification of a Request Manager for SAE J1939
Document Owner	AUTOSAR
Document Responsibility	AUTOSAR
Document Identification No	611

Document Status	published
Part of AUTOSAR Standard	Classic Platform
Part of Standard Release	R23-11

Document Change History			
Date	Release	Changed by	Description
2023-11-23	R23-11	AUTOSAR Release Management	<ul style="list-style-type: none"> Fixed include file for configurable callouts Fixed reference to J1939Rm_CheckReceivedComIPdu, fixed name of J1939RmRequest2QueueSize, fixed description of destAddress of J1939Rm_CancelRequestTimeout Added information about automatic handle IDs to configuration J1939Rm_AckCode and J1939Rm_ExtIdType changed to <code>uint8</code>
2022-11-24	R22-11	AUTOSAR Release Management	<ul style="list-style-type: none"> No content changes
2021-11-25	R21-11	AUTOSAR Release Management	<ul style="list-style-type: none"> Converted to \LaTeX Fixed <code>UserId</code> parameter range Extended acronym and related documents tables Improved linking of terms
2020-11-30	R20-11	AUTOSAR Release Management	<ul style="list-style-type: none"> Improved structure of error sections Replaced error descriptions with generated tables





2019-11-28	R19-11	AUTOSAR Release Management	<ul style="list-style-type: none"> • Cleaned up EcuC diagrams • Improved service port tables • Changed Document Status from Final to published
2018-10-31	4.4.0	AUTOSAR Release Management	<ul style="list-style-type: none"> • Changed header file structure • Improved name of J1939Rm_ComRxIpduCallout • Harmonized J1939RM_E_UNINIT • Routing of RQST/RQST2/ACKM
2017-12-08	4.3.1	AUTOSAR Release Management	<ul style="list-style-type: none"> • Clarified availability of J1939Rm_ComRxIpduCallout • Added internal feedback of ACKM • Clarification of extIdInfo parameter and underlying standard • Improved parameter checks
2016-11-30	4.3.0	AUTOSAR Release Management	<ul style="list-style-type: none"> • Request2 support • Improved handling of meta data • Reliable TxConfirmation replaces timeout • Separate configuration of different users
2015-07-31	4.2.2	AUTOSAR Release Management	<ul style="list-style-type: none"> • Fixed names and signatures of service ports • Support for explicit broadcast of ACKM • Introduction of further error classes
2014-10-31	4.2.1	AUTOSAR Release Management	<ul style="list-style-type: none"> • Improved interaction with COM • Harmonized with SWS BSW General
2014-03-31	4.1.3	AUTOSAR Release Management	<ul style="list-style-type: none"> • Clarified availability of callbacks • Standardized callback header names • Fixed UserType Enum



△

2013-10-31	4.1.2	AUTOSAR Release Management	<ul style="list-style-type: none">• Additional development error for function parameter checks• Clarification of Request timeout and state handling• Separate configuration of received and transmitted PGNs• Removed change documentation
2013-03-15	4.1.1	AUTOSAR Administration	<ul style="list-style-type: none">• Initial Release

Disclaimer

This work (specification and/or software implementation) and the material contained in it, as released by AUTOSAR, is for the purpose of information only. AUTOSAR and the companies that have contributed to it shall not be liable for any use of the work.

The material contained in this work is protected by copyright and other types of intellectual property rights. The commercial exploitation of the material contained in this work requires a license to such intellectual property rights.

This work may be utilized or reproduced without any modification, in any form or by any means, for informational purposes only. For any other purpose, no part of the work may be utilized or reproduced, in any form or by any means, without permission in writing from the publisher.

The work has been developed for automotive applications only. It has neither been developed, nor tested for non-automotive applications.

The word AUTOSAR and the AUTOSAR logo are registered trademarks.

Contents

1	Introduction and functional overview	9
1.1	Request Management according to SAE J1939	9
1.2	J1939 Request Manager BSW Module	9
1.3	J1939 Terminology	10
2	Acronyms and Abbreviations	11
3	Related documentation	12
3.1	Input documents & related standards and norms	12
3.2	Related specification	13
4	Constraints and assumptions	14
4.1	Limitations	14
4.2	Applicability to car domains	14
5	Dependencies to other modules	15
5.1	File structure	15
5.1.1	Code file structure	15
5.1.2	Header file structure	15
6	Requirements Tracing	16
7	Functional specification	18
7.1	Overview	18
7.2	Module Handling	18
7.2.1	Initialization	18
7.2.2	Timing Related Functionality	19
7.3	Communication State Handling	19
7.4	Reception of Requests	19
7.4.1	Request Forwarding	20
7.4.2	Request Handling via COM	20
7.4.3	Request of Unknown PGNs	21
7.5	Transmission of Acknowledgements	21
7.6	Transmission of Requests	22
7.7	Reception of Acknowledgements	23
7.8	Timeout Supervision	24
7.9	Routing of Requests and Acknowledgements	25
7.10	Error Classification	26
7.10.1	Development Errors	26
7.10.2	Runtime Errors	27
7.10.3	Transient Faults	27
7.10.4	Production Errors	27
7.10.5	Extended Production Errors	27
8	API specification	28

8.1	API Parameter Checking	28
8.2	Imported types	28
8.3	Type definitions	29
8.3.1	J1939Rm_ConfigType	29
8.3.2	J1939Rm_StateType	29
8.4	Function definitions	30
8.4.1	J1939Rm_Init	30
8.4.2	J1939Rm_DelInit	30
8.4.3	J1939Rm_GetVersionInfo	31
8.4.4	J1939Rm_SetState	31
8.4.5	J1939Rm_SendRequest	32
8.4.6	J1939Rm_CancelRequestTimeout	33
8.4.7	J1939Rm_SendAck	35
8.5	Callback notifications	36
8.5.1	J1939Rm_RxIndication	36
8.5.2	J1939Rm_TxConfirmation	37
8.5.3	J1939Rm_CheckReceivedComIPdu	37
8.6	Scheduled functions	38
8.6.1	J1939Rm_MainFunction	38
8.7	Expected interfaces	38
8.7.1	Mandatory interfaces	39
8.7.2	Optional interfaces	39
8.7.3	Configurable interfaces	39
8.7.3.1	<User>_RequestIndication	40
8.7.3.2	<User>_AckIndication	41
8.7.3.3	<User>_RequestTimeoutIndication	42
8.8	Service Interfaces	42
8.8.1	Provided Service Ports	42
8.8.1.1	J1939Rm_SendAck	43
8.8.1.2	J1939Rm_SendRequest	43
8.8.1.3	J1939Rm_CancelRequestTimeout	43
8.8.2	Required Service Ports	44
8.8.2.1	J1939Rm_AckIndication	44
8.8.2.2	J1939Rm_RequestIndication	44
8.8.2.3	J1939Rm_RequestTimeoutIndication	44
8.8.3	Client-Server Interfaces	45
8.8.3.1	AppSendAck	45
8.8.3.2	AppSendRequest	46
8.8.3.3	AppCancelRequestTimeout	47
8.8.3.4	AppAckIndication	48
8.8.3.5	AppRequestIndication	49
8.8.3.6	AppRequestTimeoutIndication	51
8.8.4	Implementation Data Types	52
8.8.4.1	J1939Rm_AckCode	52
8.8.4.2	J1939Rm_ExtIdType	53
8.8.4.3	J1939Rm_ExtIdInfoType	53

9	Sequence diagrams	54
9.1	Reception of Request PG	54
9.2	Transmission of Acknowledgement PG	54
9.3	Handling of Request for a COM Pdu	55
9.4	Handling of Request for a Diagnostic Pdu	56
9.5	Transmission of Request PG	56
9.6	Reception of Acknowledgement PG	57
9.7	Monitoring of Request Timeout	57
10	Configuration specification	59
10.1	Containers and configuration parameters	59
10.1.1	J1939Rm	66
10.1.2	J1939RmGeneral	66
10.1.3	J1939RmConfigSet	70
10.1.4	J1939RmChannel	70
10.1.5	J1939RmAckmRxPdu	72
10.1.6	J1939RmAckmTxPdu	73
10.1.7	J1939RmRqstRxPdu	74
10.1.8	J1939RmRqstTxPdu	75
10.1.9	J1939RmRqst2RxPdu	76
10.1.10	J1939RmRqst2TxPdu	76
10.1.11	J1939RmNode	77
10.1.12	J1939RmUser	78
10.1.13	J1939RmNmUser	79
10.1.14	J1939RmDcmUser	79
10.1.15	J1939RmCddUser	80
10.1.16	J1939RmRteUser	84
10.1.17	J1939RmComUser	87
10.1.18	J1939RmComIPdu	87
10.2	Published Information	89
A	History of Constraints and Specification Items	90
A.1	Constraint and Specification Item History of this Document According to AUTOSAR Release R21-11	90
A.1.1	Added Specification Items in R21-11	90
A.1.2	Changed Specification Items in R21-11	90
A.1.3	Deleted Specification Items in R21-11	90
A.2	Constraint and Specification Item History of this Document According to AUTOSAR Release R22-11	90
A.2.1	Added Specification Items in R22-11	90
A.2.2	Changed Specification Items in R22-11	90
A.2.3	Deleted Specification Items in R22-11	90
A.3	Constraint and Specification Item History of this Document According to AUTOSAR Release R23-11	91
A.3.1	Added Specification Items in R23-11	91
A.3.2	Changed Specification Items in R23-11	91

A.3.3 Deleted Specification Items in R23-11 91

B Not Applicable Requirements 92

1 Introduction and functional overview

This specification specifies the functionality, API and the configuration of the AUTOSAR Basic Software module [J1939 Request Manager](#).

1.1 Request Management according to SAE J1939

J1939 defines a special [parameter group](#) (PG) called [Request](#) (RQST, PGN = 0x0EA00), which may be used to request transmission of any other [parameter group](#). The [Request](#) parameter group just contains the PGN of the requested [parameter group](#).

Depending on the [destination address](#) used by the [Request](#) PG, the response must be sent directly to the requesting ECU, or to all ECUs. For short parameter groups with PDU1 format, the [destination address](#) is set accordingly¹, for large [parameter groups](#) the suitable transport protocol mode (BAM or CMDT, see [1, SWS SAE J1939 Transport Layer] and [2, SAE J1939-21]) is used.

Depending on the requested [parameter group](#) and the [destination address](#) of the [Request](#) PG, ECUs answer either with the requested [parameter group](#), with the special [Acknowledgement parameter group](#) (ACKM, PGN = 0x0E800), or not at all.

Finally, J1939 defines that the response to a [Request](#) will be expected within 1.25s after the [Request](#) was sent. The responding node is required to answer within 200ms.

Besides the [Request](#) PG, J1939 also defines a [Request2](#) PG (RQST2, PGN = 0x0C900). The behavior of this PG is identical to that of the [Request](#) PG, with the following extensions:

- A transmission with the [Transfer](#) PG can be requested to provide the same PG from multiple ECUs.
- [Extended identifier bytes](#) can be specified to request a defined layout of a multiplexed message.

1.2 J1939 Request Manager BSW Module

The [J1939 Request Manager](#) (J1939Rm) handles received and transmitted [Request](#), [Request2](#), and [Acknowledgement](#) PGs. It natively supports handling of incoming requests for the [AddressClaimed](#) PG and is configurable to support incoming requests for diagnostic and other J1939 PGNs. Unknown incoming requests are

¹Short [parameter groups](#) with PDU2 format have no [destination address](#), they are broadcast PGs by nature.

answered with a negative [Acknowledgement PG](#) if they address a specific [destination address](#).

The [J1939Rm](#) also supports transmission of requests and timeout supervision for the resulting [PG](#) or acknowledgement.

1.3 J1939 Terminology

The terminology of J1939 differs noticeably from the usual AUTOSAR terminology. For consistency reasons, this introduction used the terms of the J1939 specification, while the remainder of this specification will use terms that are more common within AUTOSAR:

- 'I-PDU' replaces 'parameter group'

2 Acronyms and Abbreviations

The glossary below includes acronyms and abbreviations relevant to the [J1939 Request Manager](#) that are not included in the [3, AUTOSAR Glossary].

Abbreviation / Acronym	Description
AC	J1939 AddressClaimed PG (PGN = 0x0EE00)
ACK	J1939 Acknowledgement PG (ACKM) with control byte set to 0
ACKM	J1939 Acknowledgement PG (PGN = 0x0E800)
BSW	Basic Software (module)
CA	Controller Application, role of an ECU tied to one address
CDD	Complex Driver, any software that interfaces directly with AUTOSAR BSW, but is not defined by AUTOSAR
DA	Destination address, the address of the receiver of a PG.
DET	Default Error Tracer, supports development and runtime error reporting
DP	Data Page, the most significant bit (MSB) of the 18 bit PGN
EDP	Extended Data Page, the second bit (after MSB) of the 18 bit PGN
Extended Identifier Bytes	These bytes represent multiplexor values in a multiplexed message which is requested via RQST2
J1939Rm	SAE J1939 Request Manager
MetaData	Meta data transferred alongside a PDU
NACK	J1939 Acknowledgement PG (ACKM) with control byte set to 1
PDU	Protocol Data Unit, a message transferred between the layers of the AUTOSAR stack, also known as I-PDU
PDU1	J1939 PDU Type 1, this kind of PDUs can be sent to a specific destination address
PDU2	J1939 PDU Type 2, this kind of PDUs is always sent to the whole network
PDUF	PDU Format, the middle byte of the 18 bit PGN
PDUS	PDU Specific, the lower byte of the 18 bit PGN
PG	Parameter Group
PGN	Parameter Group Number (18 bits, contains EDP, DP, PDUF, PDUS)
RQST	J1939 Request PG (PGN = 0x0EA00)
RQST2	J1939 Request2 PG (PGN = 0x0C900)
RTE	AUTOSAR Runtime Environment
SA	Source address, the address of the transmitter of a PG.
SW-C	AUTOSAR Software Component (of the Application)
XFER	J1939 Transfer PG (PGN = 0x0CA00)

3 Related documentation

3.1 Input documents & related standards and norms

- [1] Specification of a Transport Layer for SAE J1939
AUTOSAR_CP_SWS_SAEJ1939TransportLayer
- [2] SAE J1939-21 Data Link Layer
- [3] Glossary
AUTOSAR_FO_TR_Glossary
- [4] General Specification of Basic Software Modules
AUTOSAR_CP_SWS_BSWGeneral
- [5] Layered Software Architecture
AUTOSAR_CP_EXP_LayeredSoftwareArchitecture
- [6] Specification of Communication
AUTOSAR_CP_SWS_COM
- [7] Specification of PDU Router
AUTOSAR_CP_SWS_PDURouter
- [8] Specification of Network Management for SAE J1939
AUTOSAR_CP_SWS_SAEJ1939NetworkManagement
- [9] Specification of a Diagnostic Communication Manager for SAE J1939
AUTOSAR_CP_SWS_SAEJ1939DiagnosticCommunicationManager
- [10] Specification of Default Error Tracer
AUTOSAR_CP_SWS_DefaultErrorTracer
- [11] Specification of RTE Software
AUTOSAR_CP_SWS_RTE
- [12] Complex Driver design and integration guideline
AUTOSAR_CP_EXP_CDDDesignAndIntegrationGuideline
- [13] Specification of ECU Configuration
AUTOSAR_CP_TPS_ECUConfiguration
- [14] Specification of CAN Interface
AUTOSAR_CP_SWS_CANInterface
- [15] Specification of Communication Manager
AUTOSAR_CP_SWS_COMManager
- [16] Requirements on BSW Modules for SAE J1939
AUTOSAR_CP_SRS_SAEJ1939
- [17] General Requirements on Basic Software Modules
AUTOSAR_CP_SRS_BSWGeneral

- [18] Specification of Communication Stack Types
AUTOSAR_CP_SWS_CommunicationStackTypes
- [19] Specification of Standard Types
AUTOSAR_CP_SWS_StandardTypes
- [20] List of Basic Software Modules
AUTOSAR_CP_TR_BSWModuleList
- [21] System Template
AUTOSAR_CP_TPS_SystemTemplate

3.2 Related specification

AUTOSAR provides a General Specification on Basic Software modules [4, SWS BSW General], which is also valid for [SAE J1939 Request Manager](#).

Thus, the specification SWS BSW General shall be considered as additional and required specification for [SAE J1939 Request Manager](#).

4 Constraints and assumptions

4.1 Limitations

The [J1939 Request Manager](#) only implements [Request](#), [Request2](#), and [Acknowledgement](#) PGs. It does not provide support for the [Transfer](#) PG.

4.2 Applicability to car domains

J1939 is developed by the SAE as a standard for heavy-duty on-highway, farming, and construction vehicles. It is not applicable to passenger cars or light trucks.

5 Dependencies to other modules

The [5, EXP Layered Software Architecture] shows an overview of the neighboring modules of the J1939 Request Manager.

The J1939 Request Manager (J1939Rm) has direct interfaces towards COM ([6, SWS Communication]), the PDU Router (PduR, [7, SWS PDU Router]), the J1939 Network Management module (J1939Nm, [8, SWS SAE J1939 Network Management]), the J1939 Diagnostic Communication Management module (J1939Dcm, [9, SWS SAE J1939 Diagnostic Communication Manager]), and the Default Error Tracer (DET, [10, SWS Default Error Tracer]), and also to application software components (SW-Cs) via the AUTOSAR Runtime Environment (RTE, [11, SWS RTE]) and Complex Drivers (CDD, see [12, CDD Design And Integration Guideline] and [13, TPS ECU Configuration]). Besides these, there are also indirect dependencies towards the CAN Interface (CanIf, [14, SWS CAN Interface]) and the Communication Manager (ComM, [15, SWS Communication Manager]).

The J1939 Request Manager includes header files of COM, J1939Nm, J1939Dcm, PduR, DET, CDDs, and the RTE.

5.1 File structure

5.1.1 Code file structure

For details, refer to the section 5.1.6 “Code file structure” of the [4, SWS BSW General].

5.1.2 Header file structure

Besides the files defined in section 5.1.7 “Header file structure” of the [4, SWS BSW General], the J1939 Request Manager needs to include the files defined below.

[SWS_J1939Rm_00114] [J1939Rm shall include the header file `Com.h` if at least one `J1939RmComUser` is configured.] (*SRS_BSW_00301*)

[SWS_J1939Rm_00111] [J1939Rm shall include the header file `J1939Nm.h` if at least one `J1939RmNmUser` is configured.] (*SRS_BSW_00301*)

[SWS_J1939Rm_00112] [J1939Rm shall include the header file `J1939Dcm.h` if at least one `J1939RmDcmUser` is configured.] (*SRS_BSW_00301*)

[SWS_J1939Rm_00113] [J1939Rm shall include a header file named `<apiServicePrefix>_Cbk.h` for every configured `J1939RmCddUser`.] (*SRS_BSW_00301*)

Please note: Complex driver (CDD) APIs use the module prefix configured by the `apiServicePrefix` of the CDD’s module description file.

6 Requirements Tracing

The following tables reference the requirements specified in [16, SRS SAE J1939] and [17, SRS BSW General] and links to the fulfillment of these. Please note that if column “Satisfied by” is empty for a specific requirement this means that this requirement is not fulfilled by this document.

Requirement	Description	Satisfied by
[SRS_BSW_00171]	Optional functionality of a Basic-SW component that is not required in the ECU shall be configurable at pre-compile-time	[SWS_J1939Rm_00074] [SWS_J1939Rm_00075] [SWS_J1939Rm_00076] [SWS_J1939Rm_00079] [SWS_J1939Rm_00080] [SWS_J1939Rm_00081] [SWS_J1939Rm_00082] [SWS_J1939Rm_00083] [SWS_J1939Rm_00084] [SWS_J1939Rm_00085] [SWS_J1939Rm_00086] [SWS_J1939Rm_00087]
[SRS_BSW_00301]	All AUTOSAR Basic Software Modules shall only import the necessary information	[SWS_J1939Rm_00111] [SWS_J1939Rm_00112] [SWS_J1939Rm_00113] [SWS_J1939Rm_00114]
[SRS_BSW_00350]	All AUTOSAR Basic Software Modules shall allow the enabling/disabling of detection and reporting of development errors.	[SWS_J1939Rm_00011]
[SRS_BSW_00386]	The BSW shall specify the configuration and conditions for detecting an error	[SWS_J1939Rm_00011] [SWS_J1939Rm_00033] [SWS_J1939Rm_00040] [SWS_J1939Rm_00041] [SWS_J1939Rm_00067] [SWS_J1939Rm_00068] [SWS_J1939Rm_00069] [SWS_J1939Rm_00070] [SWS_J1939Rm_00071] [SWS_J1939Rm_00096]
[SRS_BSW_00407]	Each BSW module shall provide a function to read out the version information of a dedicated module implementation	[SWS_J1939Rm_00039]
[SRS_BSW_00478]	Timing limits of main functions	[SWS_J1939Rm_00043] [SWS_J1939Rm_00072]
[SRS_J1939_00012]	The J1939 Request Manager shall provide an interface for module initialization	[SWS_J1939Rm_00012] [SWS_J1939Rm_00037] [SWS_J1939Rm_00073]
[SRS_J1939_00013]	The J1939 Request Manager shall provide an interface for module shutdown	[SWS_J1939Rm_00013] [SWS_J1939Rm_00038]
[SRS_J1939_00014]	The J1939 Request Manager shall forward incoming requests to configured destinations	[SWS_J1939Rm_00002] [SWS_J1939Rm_00003] [SWS_J1939Rm_00007] [SWS_J1939Rm_00008] [SWS_J1939Rm_00063] [SWS_J1939Rm_00100] [SWS_J1939Rm_00107] [SWS_J1939Rm_00115] [SWS_J1939Rm_00116] [SWS_J1939Rm_00122]
[SRS_J1939_00015]	The J1939 Request Manager shall forward incoming acknowledgements to configured destinations	[SWS_J1939Rm_00026] [SWS_J1939Rm_00027] [SWS_J1939Rm_00028] [SWS_J1939Rm_00064] [SWS_J1939Rm_00066] [SWS_J1939Rm_00101] [SWS_J1939Rm_00106] [SWS_J1939Rm_00125] [SWS_J1939Rm_00126]
[SRS_J1939_00016]	The J1939 Request Manager shall provide an interface for transmission of request messages	[SWS_J1939Rm_00016] [SWS_J1939Rm_00021] [SWS_J1939Rm_00022] [SWS_J1939Rm_00023] [SWS_J1939Rm_00025] [SWS_J1939Rm_00054] [SWS_J1939Rm_00097] [SWS_J1939Rm_00104] [SWS_J1939Rm_00117] [SWS_J1939Rm_00118] [SWS_J1939Rm_00124]
[SRS_J1939_00017]	The J1939 Request Manager shall provide an interface for transmission of acknowledgement messages	[SWS_J1939Rm_00008] [SWS_J1939Rm_00009] [SWS_J1939Rm_00018] [SWS_J1939Rm_00019] [SWS_J1939Rm_00020] [SWS_J1939Rm_00056] [SWS_J1939Rm_00098] [SWS_J1939Rm_00103] [SWS_J1939Rm_00123]





Requirement	Description	Satisfied by
[SRS_J1939_00026]	The J1939 Request Manager shall support timeout supervision for outgoing requests	[SWS_J1939Rm_00017] [SWS_J1939Rm_00024] [SWS_J1939Rm_00029] [SWS_J1939Rm_00030] [SWS_J1939Rm_00055] [SWS_J1939Rm_00065] [SWS_J1939Rm_00099] [SWS_J1939Rm_00102] [SWS_J1939Rm_00105] [SWS_J1939Rm_00108]
[SRS_J1939_00049]	J1939 Modules shall support Meta Data	[SWS_J1939Rm_00119] [SWS_J1939Rm_00120] [SWS_J1939Rm_00121] [SWS_J1939Rm_00122] [SWS_J1939Rm_00123] [SWS_J1939Rm_00124] [SWS_J1939Rm_00125]
[SRS_J1939_00050]	The J1939 Request Manager shall route incoming requests and acknowledgements to connected channels	[SWS_J1939Rm_00127] [SWS_J1939Rm_00128] [SWS_J1939Rm_00129]

Table 6.1: Requirements Tracing

7 Functional specification

This chapter defines the behavior of the [J1939 Request Manager](#). The API of the module is defined in chapter [8](#), while the configuration is defined in chapter [10](#).

7.1 Overview

On one side, the [J1939 Request Manager](#) is responsible for routing incoming [RQST](#) and [RQST2 PGs](#) to the correct destination, and to provide an infrastructure for sending responding [ACKM PGs](#).

On the other side, the [J1939 Request Manager](#) also provides an infrastructure to send [RQST](#) and [RQST2 PGs](#), and to supervise timeout of the response(s), including but not limited to [ACKM PGs](#).

The [J1939 Request Manager](#) uses meta data items of type `CAN_ID_32` of the received and transmitted [ACKM](#) and [RQST PGs](#) to access the [source address](#), the [destination address](#), and the priority which are encoded in the CAN ID.

[SWS_J1939Rm_00119] [Meta data items of type `CAN_ID_32` contain the [source address](#) in the fourth (least significant) byte.]([SRS_J1939_00049](#))

[SWS_J1939Rm_00120] [Meta data items of type `CAN_ID_32` contain the [destination address](#) in the third byte.]([SRS_J1939_00049](#))

[SWS_J1939Rm_00121] [Meta data items of type `CAN_ID_32` contain the priority in the bits 2-4 of the first (most significant) byte, where bit 0 is the least significant bit of a byte.]([SRS_J1939_00049](#))

7.2 Module Handling

This section contains description of auxiliary functionality of the [J1939 Request Manager](#).

7.2.1 Initialization

The [J1939 Request Manager](#) is initialized via [J1939Rm_Init](#), and de-initialized via [J1939Rm_DeInit](#). Except for [J1939Rm_GetVersionInfo](#) and [J1939Rm_Init](#), the API functions of the [J1939 Request Manager](#) may only be called after the module has been properly initialized.

[SWS_J1939Rm_00012] [A call to [J1939Rm_Init](#) initializes all internal variables and sets the [J1939 Request Manager](#) to the initialized state.]([SRS_J1939_00012](#))

[SWS_J1939Rm_00013] [A call to `J1939Rm_DeInit` sets the `J1939 Request Manager` back to the uninitialized state.]([SRS_J1939_00013](#))

[SWS_J1939Rm_00011] [When `J1939Rm_Init` is called in initialized state, the `J1939 Request Manager` shall not re-initialize its internal variables. It shall instead call `Det_ReportError` with the error code `J1939RM_E_REINIT` if development error detection is enabled (see `J1939RmDevErrorDetect`).]([SRS_BSW_00350](#), [SRS_BSW_00386](#))

7.2.2 Timing Related Functionality

To be able to measure times, the `J1939 Request Manager` is triggered cyclically via the `J1939Rm_MainFunction`.

[SWS_J1939Rm_00072] [The `J1939 Request Manager` shall use the `J1939Rm_MainFunction` for timing related purposes.]([SRS_BSW_00478](#))

7.3 Communication State Handling

In general, request handling is only active when the ECU is online (see [8, SWS SAE J1939 Network Management] for details). The exceptions to this rule are received and transmitted requests for the `AddressClaimed PG`, which must be possible in all cases. The `J1939 Request Manager` provides an API that is used by the `BSW Mode Manager (BswM)` to notify the `J1939 communication state`.

[SWS_J1939Rm_00073] [During initialization via `J1939Rm_Init`, the `J1939 Request Manager` assumes the offline state for all nodes on all channels.]([SRS_J1939_00012](#))

[SWS_J1939Rm_00014] [A call to `J1939Rm_SetState` sets the state of a node's channel to online or offline.](`()`)

[SWS_J1939Rm_00015] [In the offline state, the `J1939 Request Manager` only processes requests for the `AddressClaimed PG`, while timeout supervision and acknowledgement handling are completely disabled.](`()`)

7.4 Reception of Requests

The `J1939 Request Manager` receives request PGs (`RQST` and `RQST2`) via `J1939Rm_RxIndication` from the CAN Interface. The `J1939 Request Manager` shall use the meta data item type `CAN_ID_32` to be able to identify the sender, the `destination address`, and the priority of the request.

[SWS_J1939Rm_00122] [The `J1939 Request Manager` shall use a meta data item of type `CAN_ID_32` to determine the `source address`, `destination ad-`

dress, and priority of received request PGNs.](SRS_J1939_00014, SRS_J1939_00049)

[SWS_J1939Rm_00007] [The J1939 Request Manager shall only accept requests addressed to the whole network (global DA), or to one of the configured addresses of the ECU (see J1939RmNmNodeRef).](SRS_J1939_00014)

Requests for the AddressClaimed PG (AC, PGN = 0x0EE00) always go to the J1939 Network Management module. Requests for the DMx PGNs (DM01 to DM57) always go to the J1939 Diagnostic Communication Manager, the destination of these and other PGNs is configured via J1939RmUserRequestPGN.

Besides forwarding to the J1939 Network Management module, the J1939 Diagnostic Communication Manager, and CDDs, the J1939 Request Manager can also forward requests to SW-Cs, and trigger COM to send requested PGNs.

7.4.1 Request Forwarding

Forwarding to other BSW modules is done via the generic callout function User_RequestIndication. Forwarding to SW-C uses a dedicated service port function with the same signature as the User_RequestIndication.

[SWS_J1939Rm_00002] [When J1939Rm_RxIndication is called by the PDU Router to indicate reception of a request, and the requested PGN is configured via J1939RmUserRequestPGN to trigger either the J1939 Diagnostic Communication Manager or a CDD, the J1939 Request Manager shall call the corresponding User_RequestIndication.](SRS_J1939_00014)

[SWS_J1939Rm_00116] [When J1939Rm_RxIndication is called by the PDU Router to indicate reception of a request, and the requested PGN is AddressClaimed (AC, 0x0EE00), the J1939 Request Manager shall call J1939Nm_RequestIndication.](SRS_J1939_00014)

[SWS_J1939Rm_00003] [When J1939Rm_RxIndication is called by the PDU Router to indicate reception of a request, and the requested PGN is configured via J1939RmUserRequestPGN to be forwarded to the RTE, the J1939 Request Manager shall call the corresponding service port function.](SRS_J1939_00014)

7.4.2 Request Handling via COM

If COM is configured as destination for the request of a certain PGN, the J1939 Request Manager will prepare the MetaData, and request COM to send the PDU with the MetaData provided via Com_TriggerIPDUSendWithMetaData. This sequence is shown in Figure 9.3.

[SWS_J1939Rm_00115] [When `J1939Rm_RxIndication` is called by the PDU Router to indicate reception of a request, and the requested PGN is configured via `J1939RmComIPduPGN` to be handled via COM, and when the `extended identifier bytes` of an RQST2 match the multiplexor values of a multiplexed message, the J1939 Request Manager shall prepare the `MetaData` from the given information and provide it to COM via `Com_TriggerIPDUSendWithMetaData` together with the PduId of the transmitted COM I-PDU referenced by `J1939RmComIPduRef`.] (*SRS_J1939_00014*)

7.4.3 Request of Unknown PGNs

The J1939 Request Manager shall respond to requests for unknown PGNs with a NACK, but only when the request was sent to a specific `destination address`.

[SWS_J1939Rm_00008] [When `J1939Rm_RxIndication` is called by the PDU Router to indicate reception of a request, and the requested PGN or the requested `extended identifier bytes` are not configured, and the `destination address` is not the broadcast address, the J1939 Request Manager shall call `PduR_J1939RmTransmit` to send a negative acknowledgement (NACK).] (*SRS_J1939_00014*, *SRS_J1939_00017*)

7.5 Transmission of Acknowledgements

For unknown PGNs, the J1939 Request Manager transmits a negative acknowledgement by itself (see section 7.4.3 above). Modules that receive requests from the J1939 Request Manager may use the API `J1939Rm_SendAck` to transmit the acknowledgement variants defined by the J1939 standard (see section 5.4.4 in [2, SAE J1939-21]).

The `Acknowledgement PG` is supposed to have a fixed `destination address` (0xFF), configured via `CanIfTxPduCanId` in the CAN Interface. The J1939 Request Manager shall use the meta data item type `CAN_ID_32` so that it can modify the priority and `source address`.

[SWS_J1939Rm_00009] [When a BSW module, a CDD, or an SW-C (via service port and RTE) calls `J1939Rm_SendAck`, the J1939 Request Manager shall call `PduR_J1939RmTransmit` to send the required acknowledgement.] (*SRS_J1939_00017*)

[SWS_J1939Rm_00123] [The J1939 Request Manager shall use a meta data item of type `CAN_ID_32` to provide the `source address` and priority of transmitted `Acknowledgement PGs`.] (*SRS_J1939_00017*, *SRS_J1939_00049*)

There is only one I-PDU available to send `Acknowledgement PGs`. Still, it must be ensured, that no `Acknowledgement PG` is lost, even when a new transmission is

initiated while this I-PDU is already occupied by another transmission. To achieve this, the J1939 Request Manager needs to queue Acknowledgement PGs.

[SWS_J1939Rm_00018] [Transmission requests for the Acknowledgement PG shall be queued when a previous transmission of this PG is still pending. The size of this queue is determined by J1939RmAckQueueSize.](SRS_J1939_00017)

[SWS_J1939Rm_00019] [The J1939 Request Manager shall use the J1939Rm_TxConfirmation with result E_OK of the associated I-PDU to trigger transmission of pending Acknowledgement PGs.](SRS_J1939_00017)

[SWS_J1939Rm_00020] [If the J1939Rm_TxConfirmation is called with result E_NOT_OK, the J1939 Request Manager shall flush the Acknowledgement PG queue.](SRS_J1939_00017)

The acknowledgement type (Control byte), the extended identifier bytes, and the Address parameter of the Acknowledgement PG are set according to the arguments of the J1939Rm_SendAck function. The destination address is always the global address, as defined in [2, SAE J1939-21].

[SWS_J1939Rm_00126] [When an acknowledgement is sent, it shall also be handled internally as if it was received via J1939Rm_RxIndication.](SRS_J1939_00015)

7.6 Transmission of Requests

As stated in section 7.1, the J1939 Request Manager also supports transmission of requests, reception of responding acknowledgements, and timeout supervision for the responses.

To trigger the transmission of a request, the J1939 Request Manager provides the API J1939Rm_SendRequest.

The J1939 Request Manager shall use the meta data item type CAN_ID_32 to be able to set the priority and the source and destination address freely. The CAN Interface must be configured such that the PDU and data page bits are fixed, while the remaining bits of the CAN ID are variable.

[SWS_J1939Rm_00016] [When a BSW module, a CDD, or an SW-C (via service port and RTE) calls J1939Rm_SendRequest, the J1939 Request Manager shall call PduR_J1939RmTransmit to send the request.](SRS_J1939_00016)

[SWS_J1939Rm_00117] [When no extended identifier bytes are provided with J1939Rm_SendRequest, J1939Rm shall send an RQST PG. When one or more extended identifier bytes are provided, an RQST2 PG shall be sent.](SRS_J1939_00016)

[SWS_J1939Rm_00124] [The J1939 Request Manager shall use a meta data item of type CAN_ID_32 to provide the source address, destination address,

and priority of transmitted `Request` and `Request2` PGs.]([SRS_J1939_00016](#), [SRS_J1939_00049](#))

There is only one `I-PDU` available to send `Request` PGs, and one for `Request2` PGs. Still, it must be ensured that no request PG is lost, even when a new transmission is initiated while this `I-PDU` is already occupied by another transmission. To achieve this, the `J1939 Request Manager` needs to queue request PGs.

[SWS_J1939Rm_00021] [Transmission requests for the `Request` PG shall be queued when a previous transmission of this PG is still pending. The size of this queue is determined by `J1939RmRequestQueueSize`.]([SRS_J1939_00016](#))

[SWS_J1939Rm_00118] [Transmission requests for the `Request2` PG shall be queued when a previous transmission of this PG is still pending. The size of this queue is determined by `J1939RmRequest2QueueSize`.]([SRS_J1939_00016](#))

[SWS_J1939Rm_00022] [The `J1939 Request Manager` shall use the `J1939Rm_TxConfirmation` with result `E_OK` of the associated `I-PDU` to trigger transmission of pending `Request` and `Request2` PGs.]([SRS_J1939_00016](#))

[SWS_J1939Rm_00023] [If the `J1939Rm_TxConfirmation` is called with result `E_NOT_OK`, the `J1939 Request Manager` shall flush the corresponding request PG queue.]([SRS_J1939_00016](#))

To be able to do timeout supervision, the `J1939 Request Manager` needs to remember the initiator, the `destination address`, `extended identifier bytes`, and the `PGN` of the request.

[SWS_J1939Rm_00024] [When `J1939Rm_SendRequest` is called with the parameter `checkTimeout` set to `TRUE` and a `destination address` that is not the broadcast address (`0xFF`), and timeout handling is enabled for the caller via `J1939RmUserTimeoutSupervision`: The `J1939 Request Manager` shall store (separately for each node) the calling module's user ID, the `PGN`, `extended identifier bytes`, the `source address`, and the `destination address` of the request.]([SRS_J1939_00026](#))

Finally, requests to the global address must also be handled internally as described in section 7.4.

[SWS_J1939Rm_00025] [When a request is sent with the global `destination address`, it shall also be handled internally as if it was received via `J1939Rm_RxIndication`.]([SRS_J1939_00016](#))

7.7 Reception of Acknowledgements

The `J1939 Request Manager` receives `Acknowledgement` PGs (`ACKM`) via `J1939Rm_RxIndication` from the `CAN Interface`. The `J1939 Request Manager` shall use the meta data item type `CAN_ID_32` to be able to identify the priority and the sender of the acknowledgement.

[SWS_J1939Rm_00125] [The J1939 Request Manager shall use a meta data item of type CAN_ID_32 to determine the source address and priority of received Acknowledgement PGs.](SRS_J1939_00015, SRS_J1939_00049)

[SWS_J1939Rm_00026] [The J1939 Request Manager shall only accept acknowledgements where the AddressAcknowledged is set to one of the configured addresses of the ECU (see J1939RmNmNodeRef).](SRS_J1939_00015)

The scheduling of received Acknowledgement PGs is configured similarly to the Request PG, see section 7.4.1, but the destinations are restricted to CDD and Application, because the J1939Nm and the J1939Dcm currently do not need to request any information from other ECUs.

[SWS_J1939Rm_00066] [When J1939Rm_RxIndication is called by the PDU Router to indicate reception of an acknowledgement which matches a pending request (acknowledged PGN, source address, acknowledged address), the J1939 Request Manager shall call the User_AckIndication or the service port function corresponding to the stored user ID.](SRS_J1939_00015)

[SWS_J1939Rm_00027] [When J1939Rm_RxIndication is called by the PDU Router to indicate reception of an acknowledgement which does not match a pending request, and the acknowledged PGN is configured via J1939RmUserAckPGN to trigger a CDD, the J1939 Request Manager shall call the corresponding User_AckIndication.](SRS_J1939_00015)

[SWS_J1939Rm_00028] [When J1939Rm_RxIndication is called by the PDU Router to indicate reception of an acknowledgement which does not match a pending request, and the acknowledged PGN is configured via J1939RmUserAckPGN to be forwarded to the RTE, the J1939 Request Manager shall call the corresponding service port function.](SRS_J1939_00015)

7.8 Timeout Supervision

The SAE J1939 specification [2, SAE J1939-21] defines a maximum delay of 200ms for the answer to a request. This delay is not supervised by the J1939 Request Manager. On the other hand, the timeout of 1.25s for the reception of the answer to a request will be supervised by the J1939 Request Manager, if configured accordingly via J1939RmUserTimeoutSupervision. In that case, when the request is transmitted, the timer is started and the request data is stored as described in [SWS_J1939Rm_00024].

[SWS_J1939Rm_00017] [If timeout supervision is enabled for the caller of J1939Rm_SendRequest via J1939RmUserTimeoutSupervision, and the parameter checkTimeout is TRUE, and the destination address is not the broadcast address (0xFF): The J1939 Request Manager shall start timeout supervision.](SRS_J1939_00026)

[SWS_J1939Rm_00029] [When an acknowledgement matching the request is received, when `J1939Rm_CheckReceivedComIPdu` is called which matches the request, or when a CDD or an application SW-C calls `J1939Rm_CancelRequestTimeout`, the timeout supervision of the request is stopped.]([SRS_J1939_00026](#))

[SWS_J1939Rm_00030] [If the timeout supervision for a request reaches 1.25s, the `J1939 Request Manager` shall call the `User_RequestTimeoutIndication` corresponding to the `userId` parameter of the initial `J1939Rm_SendRequest`.]([SRS_J1939_00026](#))

7.9 Routing of Requests and Acknowledgements

Depending on the configuration of `J1939NmSharedAddressSpace` and `J1939NmExternalNodeGatewayedChannelRef` referring to `J1939NmChannels` that reference the same `ComMChannels` as the `J1939RmChannels`, the `Request`, `Request2`, and `Acknowledgement` PGs need to be routed from one `J1939RmChannel` to another.

[SWS_J1939Rm_00127] [If `J1939RmGatewaySupport` is enabled, and a `J1939RmChannel` is linked to another `J1939RmChannel` via a `J1939NmSharedAddressSpace`: All `Request`, `Request2`, and `Acknowledgement` PGs that are received on the first `J1939RmChannel` shall be forwarded to the second `J1939RmChannel`.]([SRS_J1939_00050](#))

Note: The complete path between two `J1939RmChannels` linked via a `J1939NmSharedAddressSpace` is:

```
J1939RmChannel → J1939RmComMNetworkHandleRef → ComMChannel
Channel ← J1939NmComMNetworkHandleRef ← J1939NmChannel
← J1939NmSharedChannelRef ← J1939NmSharedAddressSpace
→ J1939NmSharedChannelRef → J1939NmChannel →
J1939NmComMNetworkHandleRef → ComMChannel ←
J1939RmComMNetworkHandleRef ← J1939RmChannel
```

[SWS_J1939Rm_00128] [If `J1939RmGatewaySupport` is enabled, and a `J1939RmChannel` is referenced by another `J1939RmChannel` via a `J1939NmExternalNodeGatewayedChannelRef`: All `Request`, `Request2`, and `Acknowledgement` PGs that are received on the first `J1939RmChannel` shall be forwarded to the second `J1939RmChannel`.]([SRS_J1939_00050](#))

Note: The complete path between two `J1939RmChannels` linked via a `J1939NmExternalNodeGatewayedChannelRef` is:

```
J1939RmChannel → J1939RmComMNetworkHandleRef → ComMChannel
nel ← J1939NmComMNetworkHandleRef ← J1939NmChannel ←
J1939NmExternalNodeGatewayedChannelRef ← J1939NmExternalNode
→ J1939NmExternalNodeChannelRef → J1939NmChannel
```

→ J1939NmComMNetworkHandleRef → ComMChannel ←
J1939RmComMNetworkHandleRef ← J1939RmChannel

[SWS_J1939Rm_00129] [Request and Request2 PGs shall only be forwarded if the destination address of the PG is the global address (0xFF) or a destination address that does not correspond to any J1939NmNodePreferredAddress referenced by a J1939RmNode that references the J1939RmChannel on which the PG was received.] (SRS_J1939_00050)

7.10 Error Classification

The section 7.2 “Error Handling” of the [4, SWS BSW General] describes the error handling of the Basic Software in detail. Above all, it constitutes a classification scheme consisting of five error types which may occur in BSW modules.

Based on this foundation, this section specifies particular errors arranged in the respective subsections below.

7.10.1 Development Errors

[SWS_J1939Rm_00031] Definiton of development errors in module J1939Rm [

Type of error	Related error code	Error value
An API was called while the module was uninitialized	J1939RM_E_UNINIT	0x01
The Init API was called twice	J1939RM_E_REINIT	0x02
J1939Rm_Init was called with an invalid configuration pointer	J1939RM_E_INIT_FAILED	0x03
An API service was called with a NULL pointer	J1939RM_E_PARAM_POINTER	0x10
An API service was called with a wrong ID	J1939RM_E_INVALID_PDU_SDU_ID	0x11
An API service was called with wrong network handle	J1939RM_E_INVALID_NETWORK_ID	0x12
The API J1939Rm_SetState was called with a wrong state	J1939RM_E_INVALID_STATE	0x13
An API was called with an illegal user ID	J1939RM_E_INVALID_USER	0x14
An API was called with an unknown or illegal PGN	J1939RM_E_INVALID_PGN	0x15
An API was called with an illegal priority	J1939RM_E_INVALID_PRIO	0x16
An API was called with an illegal node address	J1939RM_E_INVALID_ADDRESS	0x17
An API was called with an illegal Boolean option	J1939RM_E_INVALID_OPTION	0x18
An API was called with an illegal AckCode	J1939RM_E_INVALID_ACK_CODE	0x19
An API was called with an illegal node ID	J1939RM_E_INVALID_NODE_ID	0x1a
An API was called with invalid extended identifier bytes	J1939RM_E_INVALID_EXTID_INFO	0x1b

]()

7.10.2 Runtime Errors

Runtime errors have not yet been classified.

7.10.3 Transient Faults

There are no transient faults.

7.10.4 Production Errors

There are no production errors.

7.10.5 Extended Production Errors

There are no extended production errors.

8 API specification

8.1 API Parameter Checking

The [J1939 Request Manager](#) performs parameter checks for all called APIs. It reports the development error [J1939RM_E_PARAM_POINTER](#) when a call provides a NULL pointer, [J1939RM_E_INVALID_PDU_SDU_ID](#) when a check of a PDU ID fails, [J1939RM_E_INVALID_NETWORK_ID](#) when a check of a network handle fails, and [J1939RM_E_INVALID_NODE_ID](#) when a check of a node handle fails.

[J1939RM_E_PARAM_POINTER](#) shall be reported as specified in [4, SWS BSW General] by [SWS_BSW_00212].

[SWS_J1939Rm_00033] [If development error detection is enabled via [J1939RmDevErrorDetect](#), the [J1939 Request Manager](#) shall check PduId-
Type parameters (PDU IDs) of its API functions against the configured IDs, and shall report the development error [J1939RM_E_INVALID_PDU_SDU_ID](#) when an unknown ID is provided by the call.] ([SRS_BSW_00386](#))

[SWS_J1939Rm_00041] [If development error detection is enabled via [J1939RmDevErrorDetect](#), the [J1939 Request Manager](#) shall check Net-
workHandleType parameters (network handles) of its API functions against the referenced network handles of ComM, and shall report the development error [J1939RM_E_INVALID_NETWORK_ID](#) when an unknown handle is provided by the call.] ([SRS_BSW_00386](#))

[SWS_J1939Rm_00096] [If development error detection is enabled via [J1939RmDevErrorDetect](#), the [J1939 Request Manager](#) shall check node
handle parameters of its API functions against the node handles of [J1939Nm](#) referenced via [J1939RmNmNodeRef](#), and shall report the development error [J1939RM_E_INVALID_NODE_ID](#) when an unknown handle is provided by the call.] ([SRS_BSW_00386](#))

8.2 Imported types

In this section, all types used by the [J1939 Request Manager](#) are listed together with the defining module:

[SWS_J1939Rm_00035] Definition of imported datatypes of module J1939Rm [

Module	Header File	Imported Type
ComStack_Types	ComStack_Types.h	NetworkHandleType
	ComStack_Types.h	PduIdType
	ComStack_Types.h	PduInfoType
	ComStack_Types.h	PduLengthType





Module	Header File	Imported Type
Std	Std_Types.h	Std_ReturnType
	Std_Types.h	Std_VersionInfoType

]()

The types that are declared in `ComStack_Types.h` are defined in [18, SWS Communication Stack Types], while the types declared in `Std_Types.h` are defined in [19, SWS Standard Types].

8.3 Type definitions

8.3.1 J1939Rm_ConfigType

[SWS_J1939Rm_00036] Definition of datatype J1939Rm_ConfigType [

Name	J1939Rm_ConfigType		
Kind	Structure		
Elements	implementation specific		
	Type	-	
	Comment	-	
Description	<p>This is the base type for the configuration of the J1939 Request Manager.</p> <p>A pointer to an instance of this structure will be used in the initialization of the J1939 Request Manager.</p> <p>The content of this structure is defined in chapter 10 Configuration specification.</p>		
Available via	J1939Rm.h		

]()

8.3.2 J1939Rm_StateType

[SWS_J1939Rm_00049] Definition of datatype J1939Rm_StateType [

Name	J1939Rm_StateType		
Kind	Enumeration		
Range	J1939RM_STATE_OFFLINE	0x00	Only Request for AC
	J1939RM_STATE_ONLINE	0x01	Normal communication
Description	This type represents the communication state of the J1939 Request Manager.		
Available via	J1939Rm.h		

]()

8.4 Function definitions

This is a list of functions provided for upper layer modules.

8.4.1 J1939Rm_Init

[SWS_J1939Rm_00037] Definition of API function J1939Rm_Init [

Service Name	J1939Rm_Init	
Syntax	<pre>void J1939Rm_Init (const J1939Rm_ConfigType* configPtr)</pre>	
Service ID [hex]	0x01	
Sync/Async	Synchronous	
Reentrancy	Non Reentrant	
Parameters (in)	configPtr	Pointer to selected configuration structure
Parameters (inout)	None	
Parameters (out)	None	
Return value	None	
Description	This function initializes the J1939 Request Manager.	
Available via	J1939Rm.h	

](SRS_J1939_00012)

See section 7.2.1 for details.

See section 8.1 for parameter checks.

J1939RM_E_INIT_FAILED shall be reported as specified in [4, SWS BSW General] by [SWS_BSW_00050].

8.4.2 J1939Rm_DeInit

[SWS_J1939Rm_00038] Definition of API function J1939Rm_DeInit [

Service Name	J1939Rm_DeInit	
Syntax	<pre>void J1939Rm_DeInit (void)</pre>	
Service ID [hex]	0x02	
Sync/Async	Synchronous	
Reentrancy	Non Reentrant	
Parameters (in)	None	
Parameters (inout)	None	
Parameters (out)	None	
Return value	None	





Description	This function resets the J1939 Request Manager to the uninitialized state.
Available via	J1939Rm.h

]([SRS_J1939_00013](#))

See section 7.2.1 for details.

8.4.3 J1939Rm_GetVersionInfo

[SWS_J1939Rm_00039] Definition of API function J1939Rm_GetVersionInfo [

Service Name	J1939Rm_GetVersionInfo	
Syntax	<pre>void J1939Rm_GetVersionInfo (Std_VersionInfoType* versionInfo)</pre>	
Service ID [hex]	0x03	
Sync/Async	Synchronous	
Reentrancy	Non Reentrant	
Parameters (in)	None	
Parameters (inout)	None	
Parameters (out)	versionInfo	Pointer to where to store the version information of this module.
Return value	None	
Description	Returns the version information of this module.	
Available via	J1939Rm.h	

]([SRS_BSW_00407](#))

See section 8.3.4 “Get Version Information” of [4, SWS BSW General] for details. The module ID of the [J1939 Request Manager](#) is defined in [20, TR BSW Module List].

See section 8.1 for parameter checks.

8.4.4 J1939Rm_SetState

[SWS_J1939Rm_00048] Definition of API function J1939Rm_SetState [

Service Name	J1939Rm_SetState	
Syntax	<pre>Std_ReturnType J1939Rm_SetState (NetworkHandleType channel, uint8 node, J1939Rm_StateType newState)</pre>	
Service ID [hex]	0x05	
Sync/Async	Synchronous	
Reentrancy	Reentrant	
Parameters (in)	channel	Channel for which the state shall be changed.





	node	Node for which the state shall be changed.
	newState	New state the J1939Rm shall enter, see definition of J1939Rm_StateType for available states.
Parameters (inout)	None	
Parameters (out)	None	
Return value	Std_ReturnType	E_OK: New communication state was set E_NOT_OK: Communication state was not changed due to wrong value in NewState or wrong initialization state of the module.
Description	Changes the communication state of J1939Rm to offline (only Request for AC supported) or online.	
Available via	J1939Rm.h	

]()

[SWS_J1939Rm_00040] [The [J1939 Request Manager](#) shall reject the state change by returning E_NOT_OK when the `newState` is not in the valid range. If development error detection is enabled via `J1939RmDevErrorDetect`, the development error `J1939RM_E_INVALID_STATE` shall be reported.] ([SRS_BSW_00386](#))

See section 7.2.1 for error handling and section 8.1 for parameter checks.

8.4.5 J1939Rm_SendRequest

[SWS_J1939Rm_00054] Definition of API function `J1939Rm_SendRequest` [

Service Name	J1939Rm_SendRequest	
Syntax	<pre>Std_ReturnType J1939Rm_SendRequest (uint8 userId, NetworkHandleType channel, uint32 requestedPgn, const J1939Rm_ExtIdInfoType* extIdInfo, uint8 destAddress, uint8 priority, boolean checkTimeout)</pre>	
Service ID [hex]	0x07	
Sync/Async	Synchronous	
Reentrancy	Reentrant	
Parameters (in)	userId	Identification of the calling module.
	channel	Channel on which the request shall be sent.
	requestedPgn	PGN of the requested PG.
	extIdInfo	Extended identifier bytes. J1939RM_EXTID_NONE is assumed if a NULL pointer is provided.
	destAddress	Address of the destination node or 0xFF for broadcast.
	priority	Priority of the Request PG.
	checkTimeout	TRUE: Timeout supervision will be performed FALSE: No timeout supervision will be started
Parameters (inout)	None	
Parameters (out)	None	





Return value	Std_ReturnType	E_OK: Transmission request is accepted E_NOT_OK: Transmission request is not accepted
Description	Requests transmission of a Request or Request2 PG.	
Available via	J1939Rm.h	

]([SRS_J1939_00016](#))

[SWS_J1939Rm_00074] [The [J1939Rm_SendRequest](#) API function shall only be available if [J1939RmUserSendRequest](#) is set for at least one user.]([SRS_BSW_00171](#))

See section [7.6](#) for details.

[SWS_J1939Rm_00067] [The [J1939 Request Manager](#) shall reject transmission of a request by returning E_NOT_OK when the [requestedPgn](#), the [extIdType](#) element within the [extIdInfo](#), the [destAddress](#), or the [priority](#) are not in the valid range, or when the [userId](#) is not one of the configured user IDs (see [J1939RmUserId](#)), or when [checkTimeout](#) is true but timeout handling is disabled for the calling module (see [J1939RmUserTimeoutSupervision](#)). If development error detection is enabled via [J1939RmDevErrorDetect](#), the corresponding development error shall be reported: [J1939RM_E_INVALID_USER](#) for [userId](#), [J1939RM_E_INVALID_EXTID_INFO](#) for [extIdInfo](#), [J1939RM_E_INVALID_PGN](#) for [requestedPgn](#), [J1939RM_E_INVALID_PRIO](#) for [priority](#), [J1939RM_E_INVALID_ADDRESS](#) for [destAddress](#), and [J1939RM_E_INVALID_OPTION](#) for [checkTimeout](#).]([SRS_BSW_00386](#))

[SWS_J1939Rm_00068] [The [J1939 Request Manager](#) shall reject transmission of a request by returning E_NOT_OK when another request is pending and the request queue is full.]([SRS_BSW_00386](#))

See section [7.2.1](#) for further error handling and section [8.1](#) for further parameter checks.

8.4.6 J1939Rm_CancelRequestTimeout

[SWS_J1939Rm_00055] Definition of API function [J1939Rm_CancelRequestTimeout](#) [

Service Name	J1939Rm_CancelRequestTimeout
Syntax	Std_ReturnType J1939Rm_CancelRequestTimeout (uint8 userId, NetworkHandleType channel, uint32 requestedPgn, const J1939Rm_ExtIdInfoType* extIdInfo, uint8 destAddress)
Service ID [hex]	0x08





Sync/Async	Synchronous	
Reentrancy	Reentrant	
Parameters (in)	userId	Identification of the calling module.
	channel	Channel on which the request was sent.
	requestedPgn	PGN of the requested PG.
	extIdInfo	Extended identifier bytes. J1939RM_EXTID_NONE is assumed if a NULL pointer is provided.
	destAddress	Address of the destination node.
Parameters (inout)	None	
Parameters (out)	None	
Return value	Std_ReturnType	E_OK: Cancellation of request timeout was successful E_NOT_OK: Cancellation of request timeout was not successful
Description	Cancels timeout monitoring of a request. If the request is not active, or timeout monitoring was not requested, this call has no effect.	
Available via	J1939Rm.h	

]([SRS_J1939_00026](#))

[SWS_J1939Rm_00075] [The [J1939Rm_CancelRequestTimeout](#) API function shall only be available if [J1939RmUserTimeoutSupervision](#) is set for at least one user.]([SRS_BSW_00171](#))

See section [7.8](#) for details.

[SWS_J1939Rm_00069] [The [J1939 Request Manager](#) shall ignore the timeout cancellation request when the [requestedPgn](#), the [extIdType](#) element within the [extIdInfo](#), or the [destAddress](#) are not in the valid range, or when the [userId](#) is not one of the configured user IDs (see [J1939RmUserId](#)), or if no suitable entry can be found in the list of pending requests. If development error detection is enabled via [J1939RmDevErrorDetect](#), the corresponding development error shall be reported: [J1939RM_E_INVALID_USER](#) for [userId](#), [J1939RM_E_INVALID_PGN](#) for [requestedPgn](#), [J1939RM_E_INVALID_EXTID_INFO](#) for [extIdInfo](#), and [J1939RM_E_INVALID_ADDRESS](#) for [destAddress](#).]([SRS_BSW_00386](#))

See section [7.2.1](#) for further error handling and section [8.1](#) for further parameter checks.

8.4.7 J1939Rm_SendAck

[SWS_J1939Rm_00056] Definition of API function J1939Rm_SendAck [

Service Name	J1939Rm_SendAck	
Syntax	<pre>Std_ReturnType J1939Rm_SendAck (uint8 userId, NetworkHandleType channel, uint32 ackPgn, const J1939Rm_ExtIdInfoType* extIdInfo, J1939Rm_AckCode ackCode, uint8 ackAddress, uint8 priority, boolean broadcast)</pre>	
Service ID [hex]	0x09	
Sync/Async	Synchronous	
Reentrancy	Reentrant	
Parameters (in)	userId	Identification of the calling module.
	channel	Channel on which the acknowledgement shall be sent.
	ackPgn	Acknowledged PGN.
	extIdInfo	Extended identifier bytes. J1939RM_EXTID_NONE is assumed if a NULL pointer is provided.
	ackCode	Type of acknowledgement, see definition of J1939Rm_AckCode for available codes.
	ackAddress	Address of the node that sent the request.
	priority	Priority of the Acknowledgement PG.
	broadcast	Indicates whether the ACKM is a response to a broadcast request.
Parameters (inout)	None	
Parameters (out)	None	
Return value	Std_ReturnType	E_OK: Transmission request is accepted E_NOT_OK: Transmission request is not accepted
Description	Requests transmission of an Acknowledgement PG.	
Available via	J1939Rm.h	

]([SRS_J1939_00017](#))

[SWS_J1939Rm_00076] [The [J1939Rm_SendAck](#) API function shall only be available if [J1939RmUserSendAck](#) is set for at least one user.]([SRS_BSW_00171](#))

See section [7.5](#) for details.

[SWS_J1939Rm_00070] [The [J1939 Request Manager](#) shall reject transmission of an acknowledgement by returning E_NOT_OK when the [ackPgn](#), the [extIdType](#) element within the [extIdInfo](#), the [ackAddress](#), or the [priority](#) are not in the valid range, or when the [userId](#) is not one of the configured user IDs (see [J1939RmUserId](#)). If development error detection is enabled via [J1939RmDevErrorDetect](#), the corresponding development error shall be reported: [J1939RM_E_INVALID_USER](#) for [userId](#), [J1939RM_E_INVALID_EXTID_INFO](#) for [extIdInfo](#), [J1939RM_E_INVALID_PGN](#) for [ackPgn](#), [J1939RM_E_INVALID_ACK_CODE](#) for [ackCode](#), [J1939RM_E_INVALID_ADDRESS](#) for [ackAddress](#), and [J1939RM_E_INVALID_PRIO](#) for [priority](#).]([SRS_BSW_00386](#))

[SWS_J1939Rm_00071] [The [J1939 Request Manager](#) shall reject transmission of an acknowledgement by returning `E_NOT_OK` when another acknowledgement is pending and the acknowledgement queue is full.]([SRS_BSW_00386](#))

See section [7.2.1](#) for further error handling and section [8.1](#) for further parameter checks.

8.5 Callback notifications

This is a list of functions provided for other modules.

8.5.1 J1939Rm_RxIndication

[SWS_J1939Rm_00058] Definition of callback function `J1939Rm_RxIndication` [

Service Name	J1939Rm_RxIndication	
Syntax	<pre>void J1939Rm_RxIndication (PduIdType RxPduId, const PduInfoType* PduInfoPtr)</pre>	
Service ID [hex]	0x42	
Sync/Async	Synchronous	
Reentrancy	Reentrant for different PduIds. Non reentrant for the same PduId.	
Parameters (in)	RxPduId	ID of the received PDU.
	PduInfoPtr	Contains the length (<code>SduLength</code>) of the received PDU, a pointer to a buffer (<code>SduDataPtr</code>) containing the PDU, and the <code>MetaData</code> related to this PDU.
Parameters (inout)	None	
Parameters (out)	None	
Return value	None	
Description	Indication of a received PDU from a lower layer communication interface module.	
Available via	J1939Rm.h	

]()

[SWS_J1939Rm_00080] [The `J1939Rm_RxIndication` call back function shall only be available if `J1939RmUserAckIndication` or `J1939RmUserRequestIndication` is set for at least one user.]([SRS_BSW_00171](#))

See sections [7.4](#) and [7.7](#) for details.

See section [7.2.1](#) for error handling and section [8.1](#) for parameter checks.

8.5.2 J1939Rm_TxConfirmation

[SWS_J1939Rm_00059] Definition of callback function J1939Rm_TxConfirmation

Service Name	J1939Rm_TxConfirmation	
Syntax	<pre>void J1939Rm_TxConfirmation (PduIdType TxPduId, Std_ReturnType result)</pre>	
Service ID [hex]	0x40	
Sync/Async	Synchronous	
Reentrancy	Reentrant for different Pdulds. Non reentrant for the same Pdul.	
Parameters (in)	TxPdul	ID of the PDU that has been transmitted.
	result	E_OK: The PDU was transmitted. E_NOT_OK: Transmission of the PDU failed.
Parameters (inout)	None	
Parameters (out)	None	
Return value	None	
Description	The lower layer communication interface module confirms the transmission of a PDU, or the failure to transmit a PDU.	
Available via	J1939Rm.h	

]

[SWS_J1939Rm_00081] [The [J1939Rm_TxConfirmation](#) call back function shall only be available if [J1939RmUserSendAck](#) or [J1939RmUserSendRequest](#) is set for at least one user.] ([SRS_BSW_00171](#))

See sections 7.5 and 7.6 for details.

See section 7.2.1 for error handling and section 8.1 for parameter checks.

8.5.3 J1939Rm_CheckReceivedComIPdu

[SWS_J1939Rm_00062] Definition of callback function J1939Rm_CheckReceivedComIPdu

Service Name	J1939Rm_CheckReceivedComIPdu	
Syntax	<pre>boolean J1939Rm_CheckReceivedComIPdu (PduIdType PduId, const PduInfoType* PduInfoPtr)</pre>	
Service ID [hex]	0x28	
Sync/Async	Synchronous	
Reentrancy	Reentrant for different Pdulds. Non reentrant for the same Pdul.	
Parameters (in)	Pdul	ID of the received ComIPdu.
	PduInfoPtr	Length (SduLength) of the received ComIPdu and a pointer to the data of the ComIPdu (SduDataPtr).
Parameters (inout)	None	



△

Parameters (out)	None	
Return value	boolean	Shall be always true to ensure the ComIPdu is received.
Description	Reports a received ComIPdu. If this ComIPdu was requested via J1939Rm_SendRequest or the SendRequest service operation, a request timeout for this request is stopped.	
Available via	J1939Rm_Com.h	

]()

[SWS_J1939Rm_00079] [The [J1939Rm_CheckReceivedComIPdu](#) call back function shall only be available if [J1939RmUserTimeoutSupervision](#) is set for at least one user.] ([SRS_BSW_00171](#))

See section 7.8 for details.

See section 7.2.1 for error handling and section 8.1 for parameter checks.

8.6 Scheduled functions

This function is directly called by Basic Software Scheduler (SchM).

8.6.1 J1939Rm_MainFunction

[SWS_J1939Rm_00042] Definition of scheduled function **J1939Rm_MainFunction** [

Service Name	J1939Rm_MainFunction
Syntax	void J1939Rm_MainFunction (void)
Service ID [hex]	0x04
Description	Main function of the J1939 Request Manager. Used for scheduling purposes and timeout supervision.
Available via	SchM_J1939Rm.h

]()

[SWS_J1939Rm_00043] [The frequency of invocations of [J1939Rm_MainFunction](#) is determined by the configuration parameter [J1939RmMainFunctionPeriod](#).] ([SRS_BSW_00478](#))

8.7 Expected interfaces

In this section, all interfaces required from other modules are listed.

8.7.1 Mandatory interfaces

This section defines all interfaces that are required to fulfill the core functionality of the module.

[SWS_J1939Rm_00044] Definition of mandatory interfaces in module J1939Rm [

API Function	Header File	Description
PduR_J1939RmTransmit	PduR_J1939Rm.h	Requests transmission of a PDU.

]()

8.7.2 Optional interfaces

This section defines all interfaces that are required to fulfill an optional functionality of the module.

[SWS_J1939Rm_00045] Definition of optional interfaces in module J1939Rm [

API Function	Header File	Description
Com_TriggerIPDUWithMetaData	Com.h	By a call to Com_TriggerIPDUWithMetaData the AUTOSAR COM module updates its internal metadata for the I-PDU with the given ID by copying the metadata from the given position and with respect to length of the globally configured Meta DataType of this I-PDU. Then the I-PDU is triggered for transmission.
Det_ReportError	Det.h	Service to report development errors.
J1939Dcm_RequestIndication	J1939Dcm.h	Indicates reception of a Request or Request2 PG.
J1939Nm_RequestIndication	J1939Nm.h	Indicates reception of a Request or Request2 PG.

]()

[SWS_J1939Rm_00082] [The Com_TriggerIPDUWithMetaData function is only required if at least one J1939RmComUser is configured.] ([SRS_BSW_00171](#))

[SWS_J1939Rm_00083] [The J1939Dcm_RequestIndication function is only required if at least one J1939RmDcmUser is configured.] ([SRS_BSW_00171](#))

[SWS_J1939Rm_00084] [The J1939Nm_RequestIndication function is only required if at least one J1939RmNmUser is configured.] ([SRS_BSW_00171](#))

8.7.3 Configurable interfaces

In this section, all interfaces are listed where the target function could be configured. The target function is usually a call-back function. The name of this kind of interfaces is not fixed because they are configurable.

8.7.3.1 <User>_RequestIndication

[SWS_J1939Rm_00063] Definition of configurable interface < User >_Request Indication [

Service Name	< User >_RequestIndication	
Syntax	<pre>void < User >_RequestIndication (uint8 node, NetworkHandleType channel, uint32 requestedPgn, const J1939Rm_ExtIdInfoType* extIdInfo, uint8 sourceAddress, uint8 destAddress, uint8 priority)</pre>	
Service ID [hex]	0x47	
Sync/Async	Synchronous	
Reentrancy	Reentrant	
Parameters (in)	node	Node by which the request was received.
	channel	Channel on which the request was received.
	requestedPgn	PGN of the requested PG.
	extIdInfo	Extended identifier bytes.
	sourceAddress	Address of the node that sent the Request PG.
	destAddress	Address of this node or 0xFF for broadcast.
	priority	Priority of the Request PG.
Parameters (inout)	None	
Parameters (out)	None	
Return value	None	
Description	Indicates reception of a Request or Request2 PG.	
Available via	<apiServicePrefix>_J1939Rm.h, where apiServicePrefix is taken from the CDD's module definition reference via J1939RmUserCddRef	

] ([SRS_J1939_00014](#))

[SWS_J1939Rm_00085] [The configured [User_RequestIndication](#) function shall be available for each user that has [J1939RmUserRequestIndication](#) enabled.] ([SRS_BSW_00171](#))

See section 7.4 for details.

8.7.3.2 <User>_AckIndication

[SWS_J1939Rm_00064] Definition of configurable interface < User >_AckIndication

Service Name	< User >_AckIndication	
Syntax	<pre>void < User >_AckIndication (uint8 node, NetworkHandleType channel, uint32 ackPgn, const J1939Rm_ExtIdInfoType* extIdInfo, J1939Rm_AckCode ackCode, uint8 ackAddress, uint8 sourceAddress, uint8 priority)</pre>	
Service ID [hex]	0x4d	
Sync/Async	Synchronous	
Reentrancy	Reentrant	
Parameters (in)	node	Node by which the acknowledgement was received.
	channel	Channel on which the acknowledgement was received.
	ackPgn	Acknowledged PGN.
	extIdInfo	Extended identifier bytes.
	ackCode	Type of acknowledgement, see definition of J1939Rm_AckCode for available codes.
	ackAddress	Address of this node.
	sourceAddress	Address of the node that sent the Acknowledgement PG.
	priority	Priority of the Acknowledgement PG.
Parameters (inout)	None	
Parameters (out)	None	
Return value	None	
Description	Indicates reception of an Acknowledgement PG.	
Available via	<apiServicePrefix>_J1939Rm.h, where apiServicePrefix is taken from the CDD's module definition reference via J1939RmUserCddRef	

]([SRS_J1939_00015](#))

[SWS_J1939Rm_00086] [The configured [User_AckIndication](#) function shall be available for each user that has [J1939RmUserAckIndication](#) enabled.]([SRS_-BSW_00171](#))

See section [7.7](#) for details.

8.7.3.3 <User>_RequestTimeoutIndication

[SWS_J1939Rm_00065] Definition of configurable interface < User >_RequestTimeoutIndication [

Service Name	< User >_RequestTimeoutIndication	
Syntax	<pre>void < User >_RequestTimeoutIndication (uint8 node, NetworkHandleType channel, uint32 requestedPgn, const J1939Rm_ExtIdInfoType* extIdInfo, uint8 destAddress)</pre>	
Service ID [hex]	0x4e	
Sync/Async	Synchronous	
Reentrancy	Reentrant	
Parameters (in)	node	Node by which the request was sent.
	channel	Channel on which the request was sent.
	requestedPgn	PGN of the requested PG.
	extIdInfo	Extended identifier bytes.
	destAddress	Address of the destination node or 0xFF for broadcast.
Parameters (inout)	None	
Parameters (out)	None	
Return value	None	
Description	Indicates timeout of a request triggered with the same parameters.	
Available via	<apiServicePrefix>_J1939Rm.h, where apiServicePrefix is taken from the CDD's module definition reference via J1939RmUserCddRef	

]([SRS_J1939_00026](#))

[SWS_J1939Rm_00087] [The configured [User_RequestTimeoutIndication](#) function shall be available for each user that has [J1939RmUserTimeoutSupervision](#) enabled.]([SRS_BSW_00171](#))

See section 7.8 for details.

8.8 Service Interfaces

This section defines the client server interfaces and the derived service ports used by [J1939Rm](#) to communicate with application software components ([SWCs](#)).

8.8.1 Provided Service Ports

These service ports provide API functions of the [J1939Rm](#) to the application [SWCs](#).

Please note: All three ports use a port defined argument value to provide the userId argument of the corresponding [BSW](#) interfaces.

8.8.1.1 J1939Rm_SendAck

[SWS_J1939Rm_00098] Definition of Port J1939Rm_SendAck_{user} provided by module J1939Rm [

Name	J1939Rm_SendAck_{user}		
Kind	ProvidedPort	Interface	AppSendAck
Description	–		
Port Defined Argument Value(s)	Type	uint8	
	Value	{ecuc(J1939Rm/J1939RmConfigSet/J1939RmNode/J1939RmUser/J1939RmRteUser/J1939RmUserId.value)}	
Variation	{ecuc(J1939Rm/J1939RmGeneral.J1939RmSupportAckTransmission)} == true user = {ecuc(J1939Rm/J1939RmConfigSet/J1939RmNode/J1939RmUser.SHORT-NAME)}		

]([SRS_J1939_00017](#))

8.8.1.2 J1939Rm_SendRequest

[SWS_J1939Rm_00097] Definition of Port J1939Rm_SendRequest_{user} provided by module J1939Rm [

Name	J1939Rm_SendRequest_{user}		
Kind	ProvidedPort	Interface	AppSendRequest
Description	–		
Port Defined Argument Value(s)	Type	uint8	
	Value	{ecuc(J1939Rm/J1939RmConfigSet/J1939RmNode/J1939RmUser/J1939RmRteUser/J1939RmUserId.value)}	
Variation	{ecuc(J1939Rm/J1939RmGeneral.J1939RmSupportRequestTransmission)} == true user = {ecuc(J1939Rm/J1939RmConfigSet/J1939RmNode/J1939RmUser.SHORT-NAME)}		

]([SRS_J1939_00016](#))

8.8.1.3 J1939Rm_CancelRequestTimeout

[SWS_J1939Rm_00099] Definition of Port J1939Rm_CancelRequestTimeout_{user} provided by module J1939Rm [

Name	J1939Rm_CancelRequestTimeout_{user}		
Kind	ProvidedPort	Interface	AppCancelRequestTimeout
Description	–		
Port Defined Argument Value(s)	Type	uint8	
	Value	{ecuc(J1939Rm/J1939RmConfigSet/J1939RmNode/J1939RmUser/J1939RmRteUser/J1939RmUserId.value)}	
Variation	{ecuc(J1939Rm/J1939RmGeneral.J1939RmSupportTimeoutSupervision)} == true user = {ecuc(J1939Rm/J1939RmConfigSet/J1939RmNode/J1939RmUser.SHORT-NAME)}		

]([SRS_J1939_00026](#))

8.8.2 Required Service Ports

These service ports provide call back functions of the J1939Rm to the application SWCs.

8.8.2.1 J1939Rm_AckIndication

[SWS_J1939Rm_00101] Definition of Port J1939Rm_AckIndication_{user} required by module J1939Rm [

Name	J1939Rm_AckIndication_{user}		
Kind	RequiredPort	Interface	AppAckIndication
Description	–		
Variation	{ecuc(J1939Rm/J1939RmGeneral.J1939RmSupportAckIndication)} == true user = {ecuc(J1939Rm/J1939RmConfigSet/J1939RmNode/J1939RmUser.SHORT-NAME)}		

]([SRS_J1939_00015](#))

8.8.2.2 J1939Rm_RequestIndication

[SWS_J1939Rm_00100] Definition of Port J1939Rm_RequestIndication_{user} required by module J1939Rm [

Name	J1939Rm_RequestIndication_{user}		
Kind	RequiredPort	Interface	AppRequestIndication
Description	–		
Variation	{ecuc(J1939Rm/J1939RmGeneral.J1939RmSupportRequestIndication)} == true user = {ecuc(J1939Rm/J1939RmConfigSet/J1939RmNode/J1939RmUser.SHORT-NAME)}		

]([SRS_J1939_00014](#))

8.8.2.3 J1939Rm_RequestTimeoutIndication

[SWS_J1939Rm_00102] Definition of Port J1939Rm_RequestTimeoutIndication_{user} required by module J1939Rm [

Name	J1939Rm_RequestTimeoutIndication_{user}		
Kind	RequiredPort	Interface	AppRequestTimeoutIndication
Description	–		
Variation	{ecuc(J1939Rm/J1939RmGeneral.J1939RmSupportTimeoutSupervision)} == true user = {ecuc(J1939Rm/J1939RmConfigSet/J1939RmNode/J1939RmUser.SHORT-NAME)}		

]([SRS_J1939_00026](#))

8.8.3 Client-Server Interfaces

This section lists the client-server interfaces used by the ports provided and required by the [J1939 Request Manager](#).

Please note: The availability of these interfaces depends on the configuration of the [J1939 Request Manager](#). The relevant parameters of the [J1939 Request Manager](#) configuration are listed as “Variation” of the operations.

8.8.3.1 AppSendAck

[SWS_J1939Rm_00103] Definition of ClientServerInterface AppSendAck [

Name	AppSendAck		
Comment	–		
IsService	true		
Variation	{ecuc(J1939Rm/J1939RmGeneral.J1939RmSupportAckTransmission)} == true		
Possible Errors	0	E_OK	Operation successful
	1	E_NOT_OK	Operation failed

Operation	SendAck		
Comment	Requests transmission of an Acknowledgement PG.		
Mapped to API	J1939Rm_SendAck		
Variation	–		
Parameters	channel		
	Type	NetworkHandleType	
	Direction	IN	
	Comment	Channel on which the acknowledgement shall be sent.	
	Variation	–	
	ackPgn		
	Type	uint32	
	Direction	IN	
	Comment	Acknowledged PGN.	
	Variation	–	
	extIdInfo		
	Type	J1939Rm_ExtIdInfoType	
	Direction	IN	
	Comment	–	
	Variation	–	
	ackCode		
Type	J1939Rm_AckCode		
Direction	IN		
Comment	Type of acknowledgement, see definition of J1939Rm_AckCode for available codes.		
Variation	–		
ackAddress			





	Type	uint8
	Direction	IN
	Comment	Address of the node that sent the request.
	Variation	–
	priority	
	Type	uint8
	Direction	IN
	Comment	Priority of the Acknowledgement PG.
	Variation	–
	broadcast	
	Type	boolean
	Direction	IN
	Comment	Indicates whether the ACKM is a response to a broadcast request.
Variation	–	
Possible Errors	E_OK E_NOT_OK	

](SRS_J1939_00017)

8.8.3.2 AppSendRequest

[SWS_J1939Rm_00104] Definition of ClientServerInterface AppSendRequest [

Name	AppSendRequest		
Comment	–		
IsService	true		
Variation	{ecuc(J1939Rm/J1939RmGeneral.J1939RmSupportRequestTransmission)} == true		
Possible Errors	0	E_OK	Operation successful
	1	E_NOT_OK	Operation failed

Operation	SendRequest		
Comment	Requests transmission of a Request or Request2 PG.		
Mapped to API	J1939Rm_SendRequest		
Variation	–		
Parameters	channel		
	Type	NetworkHandleType	
	Direction	IN	
	Comment	Channel on which the request shall be sent.	
	Variation	–	
	requestedPgn		
	Type	uint32	
	Direction	IN	
	Comment	PGN of the requested PG.	
	Variation	–	





	extIdInfo	
	Type	J1939Rm_ExtIdInfoType
	Direction	IN
	Comment	–
	Variation	–
	destAddress	
	Type	uint8
	Direction	IN
	Comment	Address of the destination node or 0xFF for broadcast.
	Variation	–
	priority	
	Type	uint8
	Direction	IN
	Comment	Priority of the Request PG.
	Variation	–
	checkTimeout	
Type	boolean	
Direction	IN	
Comment	TRUE: Timeout supervision will be performed FALSE: No timeout supervision will be started	
Variation	–	
Possible Errors	E_OK E_NOT_OK	

]([SRS_J1939_00016](#))

8.8.3.3 AppCancelRequestTimeout

[SWS_J1939Rm_00105] Definition of ClientServerInterface AppCancelRequest Timeout [

Name	AppCancelRequestTimeout		
Comment	–		
IsService	true		
Variation	{ecuc(J1939Rm/J1939RmGeneral.J1939RmSupportTimeoutSupervision)} == true		
Possible Errors	0	E_OK	Operation successful
	1	E_NOT_OK	Operation failed

Operation	CancelRequestTimeout	
Comment	Cancels timeout monitoring of a request. If the request is not active, or timeout monitoring was not requested, this call has no effect.	
Mapped to API	J1939Rm_CancelRequestTimeout	
Variation	–	
Parameters	channel	
	Type	NetworkHandleType





	Direction	IN
	Comment	Channel on which the request was sent.
	Variation	–
	requestedPgn	
	Type	uint32
	Direction	IN
	Comment	PGN of the requested PG.
	Variation	–
	extIdInfo	
	Type	J1939Rm_ExtIdInfoType
	Direction	IN
	Comment	–
	Variation	–
	destAddress	
	Type	uint8
Direction	IN	
Comment	Address of the destination node.	
Variation	–	
Possible Errors	E_OK E_NOT_OK	

]([SRS_J1939_00026](#))

8.8.3.4 AppAckIndication

[SWS_J1939Rm_00106] Definition of ClientServerInterface AppAckIndication [

Name	AppAckIndication		
Comment	–		
IsService	true		
Variation	{ecuc(J1939Rm/J1939RmGeneral.J1939RmSupportAckIndication)} == true		
Possible Errors	0	E_OK	Operation successful
	1	E_NOT_OK	Operation failed

Operation	AckIndication		
Comment	Indicates reception of an Acknowledgement PG.		
Mapped to API	< User >_AckIndication		
Variation	–		
Parameters	node		
	Type	uint8	
	Direction	IN	
	Comment	Node by which the acknowledgement was received.	
	Variation	–	
	channel		
Type	NetworkHandleType		





	Direction	IN
	Comment	Channel on which the acknowledgement was received.
	Variation	–
	ackPgn	
	Type	uint32
	Direction	IN
	Comment	Acknowledged PGN.
	Variation	–
	extIdInfo	
	Type	J1939Rm_ExtIdInfoType
	Direction	IN
	Comment	Extended identifier bytes.
	Variation	–
	ackCode	
	Type	J1939Rm_AckCode
	Direction	IN
	Comment	Type of acknowledgement, see definition of J1939Rm_AckCode for available codes.
	Variation	–
	ackAddress	
	Type	uint8
	Direction	IN
	Comment	Address of this node.
	Variation	–
	sourceAddress	
	Type	uint8
	Direction	IN
	Comment	Address of the node that sent the Acknowledgement PG.
	Variation	–
	priority	
	Type	uint8
	Direction	IN
	Comment	Priority of the Acknowledgement PG.
	Variation	–
Possible Errors	E_OK E_NOT_OK	

]([SRS_J1939_00015](#))

8.8.3.5 AppRequestIndication

[[SWS_J1939Rm_00107](#)] Definition of ClientServerInterface AppRequestIndication [

Name	AppRequestIndication		
Comment	–		
IsService	true		
Variation	{ecuc(J1939Rm/J1939RmGeneral.J1939RmSupportRequestIndication)} == true		
Possible Errors	0	E_OK	Operation successful
	1	E_NOT_OK	Operation failed

Operation	RequestIndication		
Comment	Indicates reception of a Request or Request2 PG.		
Mapped to API	< User >_RequestIndication		
Variation	–		
Parameters	node		
	Type	uint8	
	Direction	IN	
	Comment	Node by which the request was received.	
	Variation	–	
	channel		
	Type	NetworkHandleType	
	Direction	IN	
	Comment	Channel on which the request was received.	
	Variation	–	
	requestedPgn		
	Type	uint32	
	Direction	IN	
	Comment	PGN of the requested PG.	
	Variation	–	
	extIdInfo		
	Type	J1939Rm_ExtIdInfoType	
	Direction	IN	
	Comment	Extended identifier bytes.	
	Variation	–	
	sourceAddress		
	Type	uint8	
	Direction	IN	
	Comment	Address of the node that sent the Request PG.	
	Variation	–	
	destAddress		
	Type	uint8	
	Direction	IN	
Comment	Address of this node or 0xFF for broadcast.		
Variation	–		
priority			
Type	uint8		
Direction	IN		
Comment	Priority of the Request PG.		
Variation	–		





Possible Errors	E_OK E_NOT_OK
------------------------	------------------

|(SRS_J1939_00014)

8.8.3.6 AppRequestTimeoutIndication

[SWS_J1939Rm_00108] Definition of ClientServerInterface AppRequestTimeout Indication [

Name	AppRequestTimeoutIndication		
Comment	–		
IsService	true		
Variation	{ecuc(J1939Rm/J1939RmGeneral.J1939RmSupportTimeoutSupervision)} == true		
Possible Errors	0	E_OK	Operation successful
	1	E_NOT_OK	Operation failed

Operation	RequestTimeoutIndication		
Comment	Indicates timeout of a request triggered with the same parameters.		
Mapped to API	< User >_RequestTimeoutIndication		
Variation	–		
Parameters	node		
	Type	uint8	
	Direction	IN	
	Comment	Node by which the request was sent.	
	Variation	–	
	channel		
	Type	NetworkHandleType	
	Direction	IN	
	Comment	Channel on which the request was sent.	
	Variation	–	
	requestedPgn		
	Type	uint32	
	Direction	IN	
	Comment	PGN of the requested PG.	
	Variation	–	
	extIdInfo		
	Type	J1939Rm_ExtIdInfoType	
	Direction	IN	
	Comment	Extended identifier bytes.	
	Variation	–	
destAddress			
Type	uint8		
Direction	IN		
Comment	Address of the destination node or 0xFF for broadcast.		





	Variation	–
Possible Errors	E_OK E_NOT_OK	

|(SRS_J1939_00026)

8.8.4 Implementation Data Types

In this section, the implementation data types used by the client-server interfaces of the J1939 Request Manager are listed.

Please note: It is essential that the implementation of the J1939 Request Manager does not define these data types twice, by including them both from the RTE generated header and the own types header.

8.8.4.1 J1939Rm_AckCode

[SWS_J1939Rm_00057] Definition of ImplementationDataType J1939Rm_Ack Code |

Name	J1939Rm_AckCode		
Kind	Type		
Derived from	uint8		
Range	J1939RM_ACK_POSITIVE	0x00	Positive Acknowledgement
	J1939RM_ACK_NEGATIVE	0x01	Negative Acknowledgement
	J1939RM_ACK_ACCESS_DENIED	0x02	Access Denied
	J1939RM_ACK_CANNOT_RESPOND	0x03	Cannot Respond
Description	This type represents the available kinds of acknowledgements.		
Variation	–		
Available via	Rte_J1939Rm_Type.h		

|()

8.8.4.2 J1939Rm_ExtIdType

[SWS_J1939Rm_91000] Definition of ImplementationDataType J1939Rm_ExtIdType

Name	J1939Rm_ExtIdType		
Kind	Type		
Derived from	uint8		
Range	J1939RM_EXTID_NONE	0x00	No extended identifier bytes (0)
	J1939RM_EXTID_ONE	0x01	One extended identifier byte (1)
	J1939RM_EXTID_TWO	0x02	Two extended identifier bytes (2)
	J1939RM_EXTID_THREE	0x03	Three extended identifier bytes (3)
	J1939RM_EXTID_GF	0x04	Group function value, only for ACKM (4)
Description	This type represents the available kinds of extended identifier usage.		
Variation	–		
Available via	Rte_J1939Rm_Type.h		

]()

8.8.4.3 J1939Rm_ExtIdInfoType

[SWS_J1939Rm_91001] Definition of ImplementationDataType J1939Rm_ExtIdInfoType

Name	J1939Rm_ExtIdInfoType		
Kind	Structure		
Elements	extIdType		
	Type	J1939Rm_ExtIdType	
	Comment	Denotes the number of extended identifier bytes.	
	extId1		
	Type	uint8	
	Comment	First extended identifier byte or group function for ACKM.	
	extId2		
	Type	uint8	
	Comment	Second extended identifier byte.	
	extId3		
Type	uint8		
Comment	Third extended identifier byte.		
Description	This type represents a set of extended identifiers.		
Variation	–		
Available via	Rte_J1939Rm_Type.h		

]()

9 Sequence diagrams

The following sequence diagrams shall give an impression of the way the [J1939 Request Manager](#) shall behave and interoperate with other [BSW](#) modules. They are not complete and not binding for the implementation.

9.1 Reception of Request PG

The following diagram shows the interaction with [PduR](#) and a [J1939Rm User](#) when a [Request PG](#) is received.

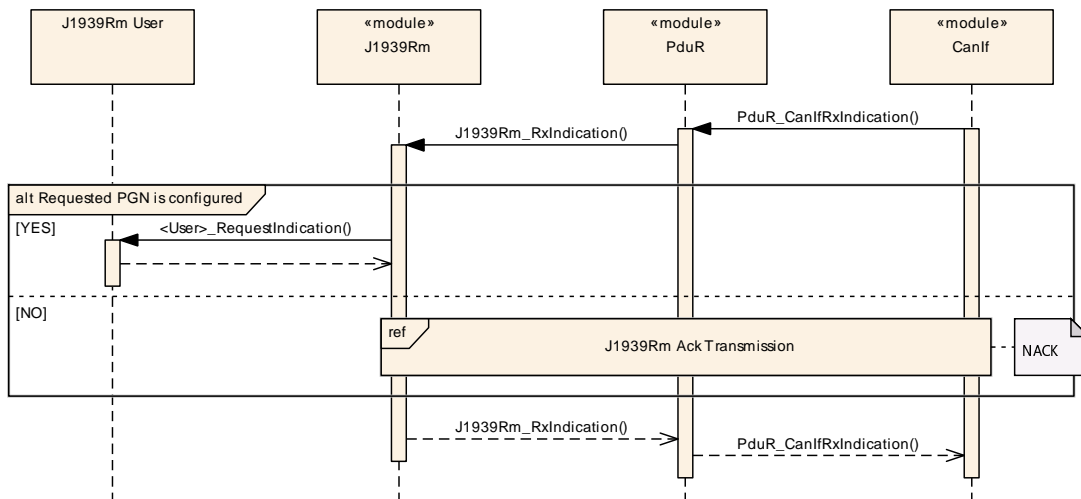

Figure 9.1: Reception of Request PG

9.2 Transmission of Acknowledgement PG

The following diagram shows the interaction with a [J1939Rm User](#) and [PduR](#) when an [Acknowledgement PG](#) is transmitted.

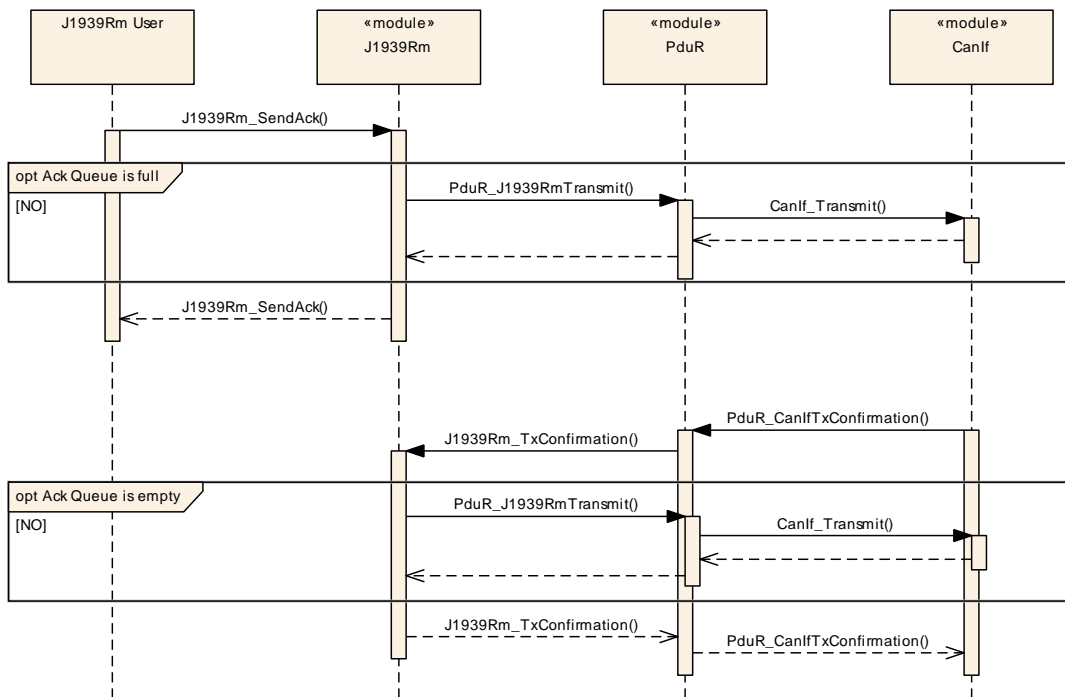

Figure 9.2: Transmission of Acknowledgement PG

9.3 Handling of Request for a COM Pdu

The following diagram shows the interaction with PduR and COM when the J1939 Request Manager receives a Request for a PG of PDU1 format that is transmitted as COM PDU.

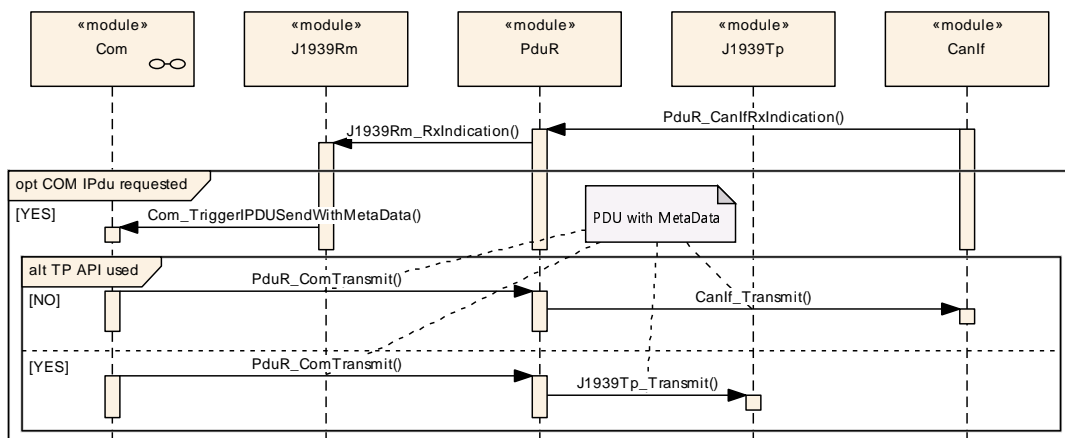

Figure 9.3: Handling of Request for a COM PDU with PDU1 format

9.4 Handling of Request for a Diagnostic Pdu

The following diagram shows the interaction with PduR and J1939Dcm when a request for a diagnostic PG is received.

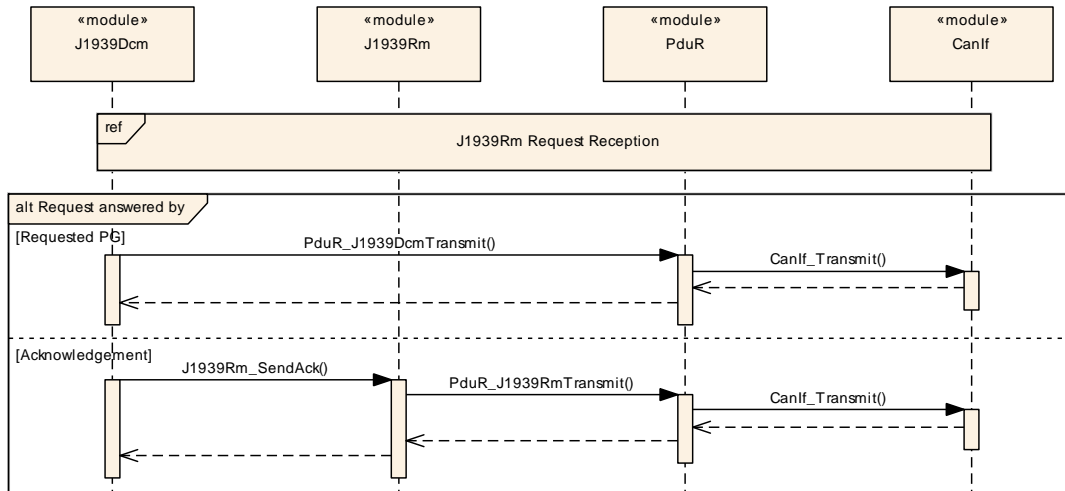

Figure 9.4: Handling of Request for a Diagnostic Pdu

9.5 Transmission of Request PG

The following diagram shows the interaction with a J1939Rm User and PduR when a Request PG is transmitted.

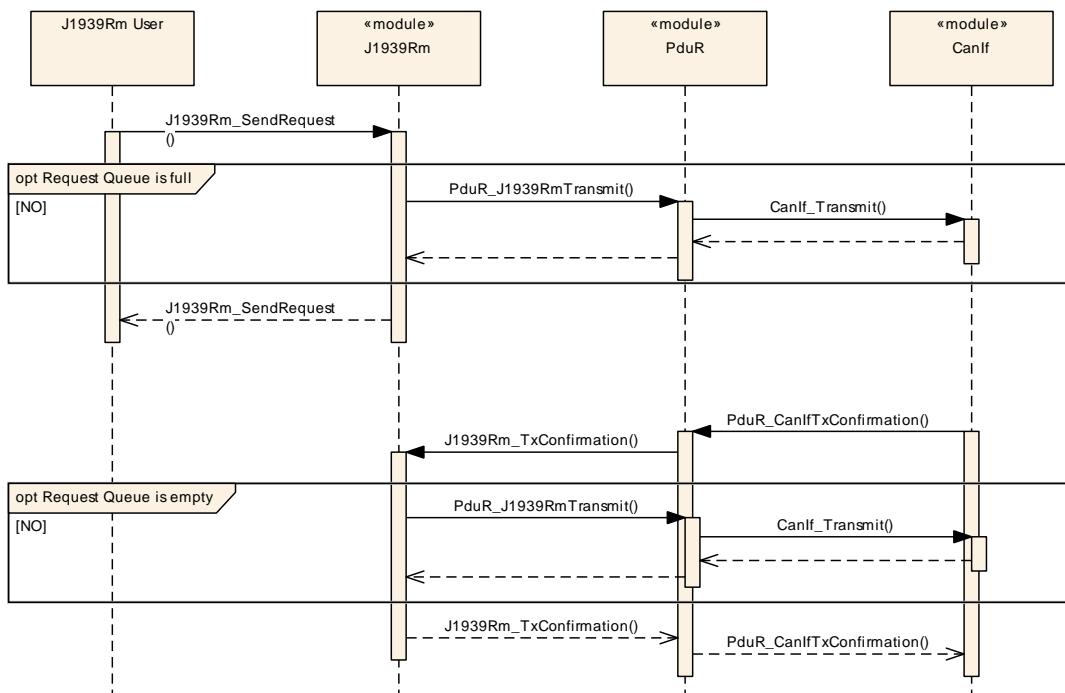

Figure 9.5: Transmission of Request PG

9.6 Reception of Acknowledgement PG

The following diagram shows the interaction with PduR and a J1939Rm User when an Acknowledgement PG is received.

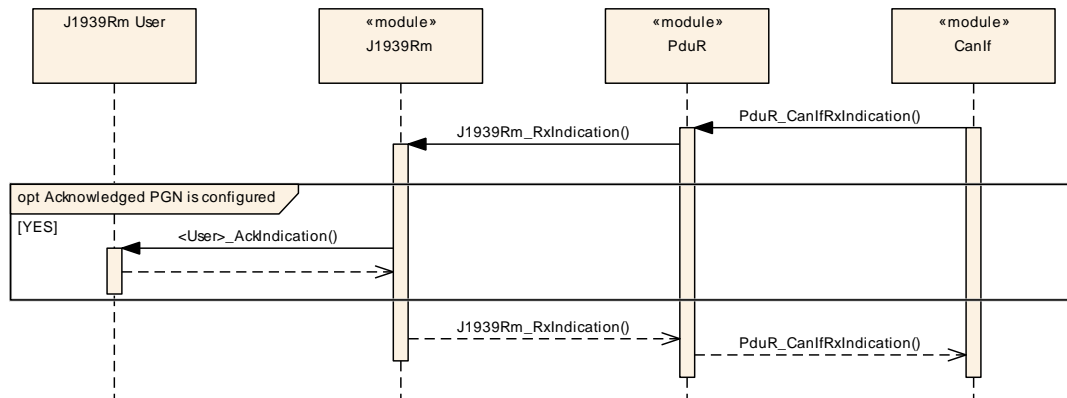

Figure 9.6: Reception of Acknowledgement PG

9.7 Monitoring of Request Timeout

The following diagram shows the interaction with a J1939Rm User and PduR when the J1939Rm monitors timeout of a transmitted Request PG.

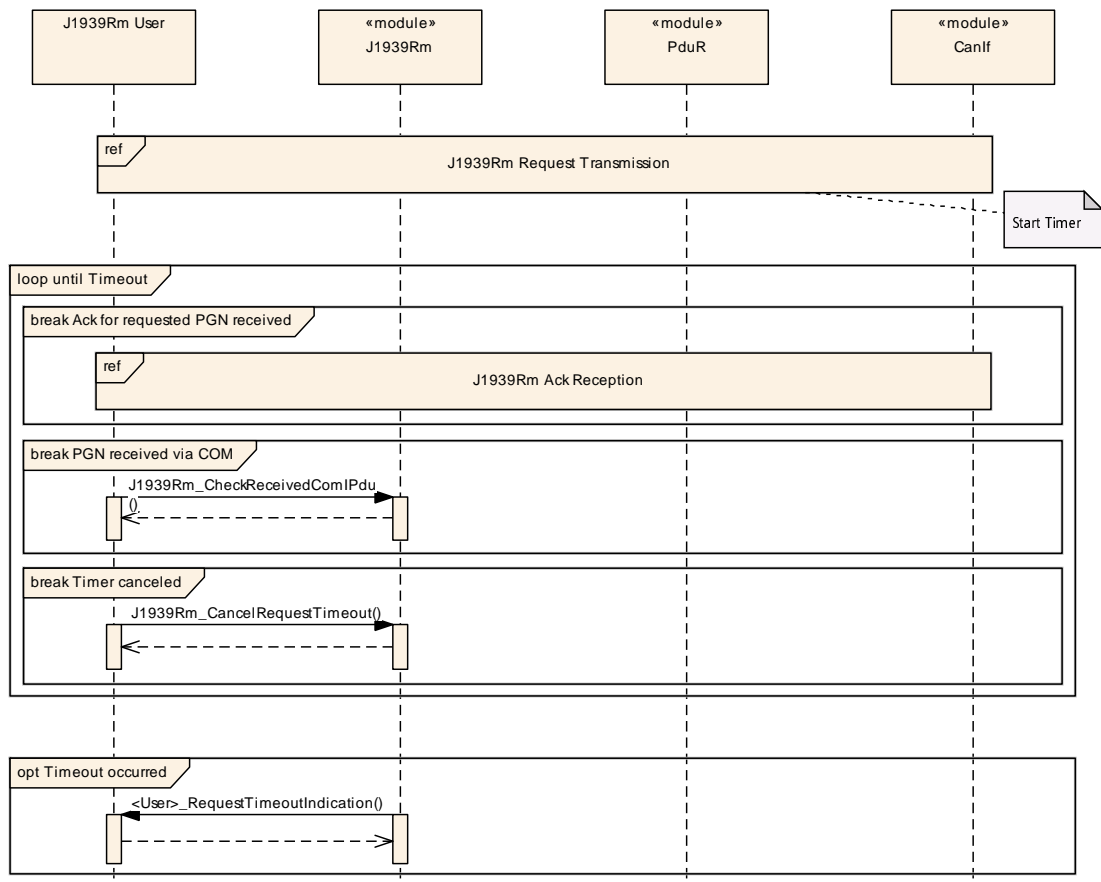

Figure 9.7: Monitoring of Request Timeout

10 Configuration specification

In general, this chapter defines configuration parameters and their clustering into containers. For general information about the definition of containers and parameters, refer to the section 10.1 “Introduction to configuration specification” in [4, SWS BSW General].

Section 10.1 specifies the structure (containers) and the parameters of the module [SAE J1939 Request Manager](#).

Section 10.2 specifies published information of the module [SAE J1939 Request Manager](#).

10.1 Containers and configuration parameters

The following sections summarize all configuration parameters of the [J1939 Request Manager](#). The detailed meaning of the parameters is described in chapters 7 and 8.

Some of these containers and parameters are derived from classes and attributes of the [21, TPS System Template], which also contains the rules for these derivations.

The following pictures show an overview of the configuration parameters available for J1939Rm:

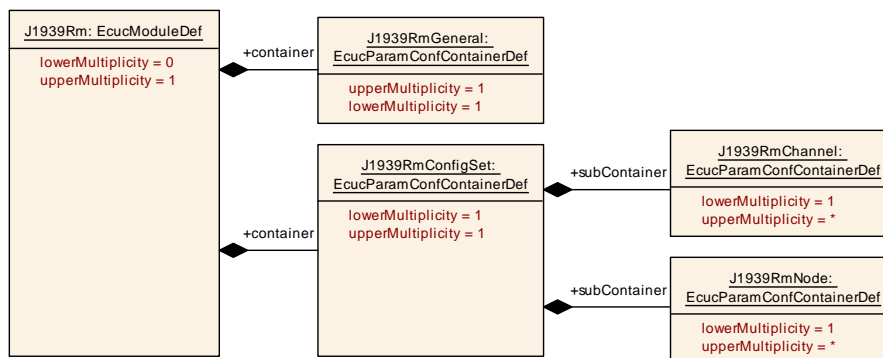

Figure 10.1: Configuration container J1939Rm with subcontainer J1939RmConfigSet

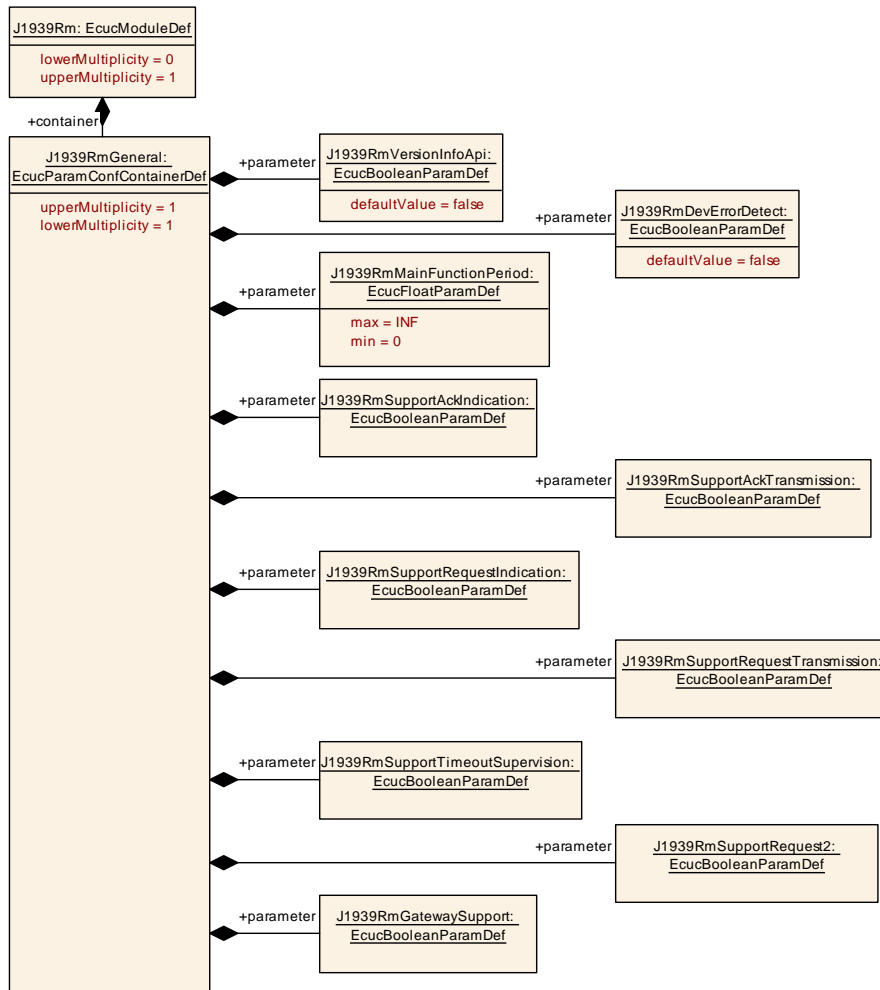

Figure 10.2: Configuration container J1939RmGeneral

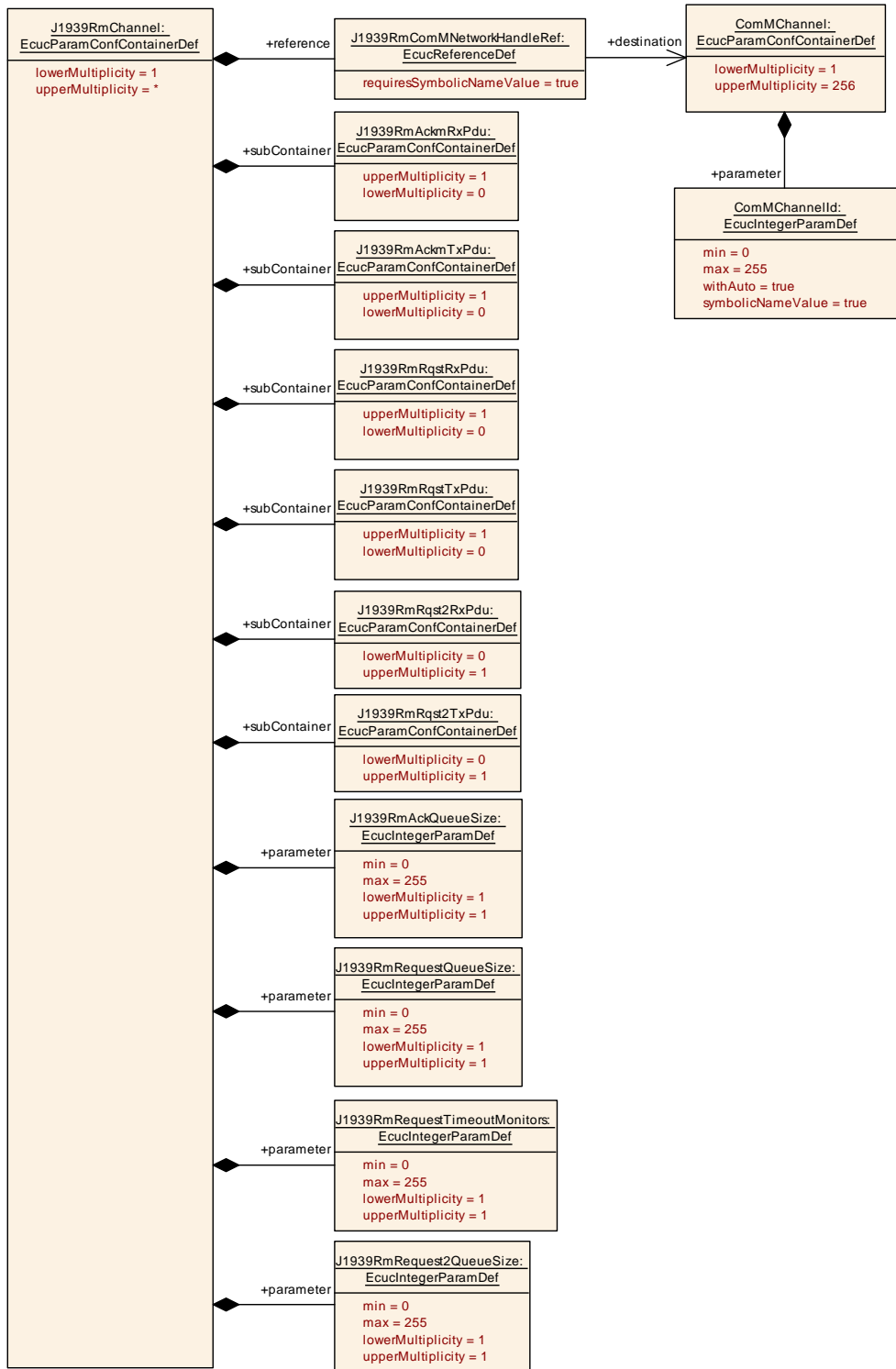

Figure 10.3: Configuration container J1939RmChannel

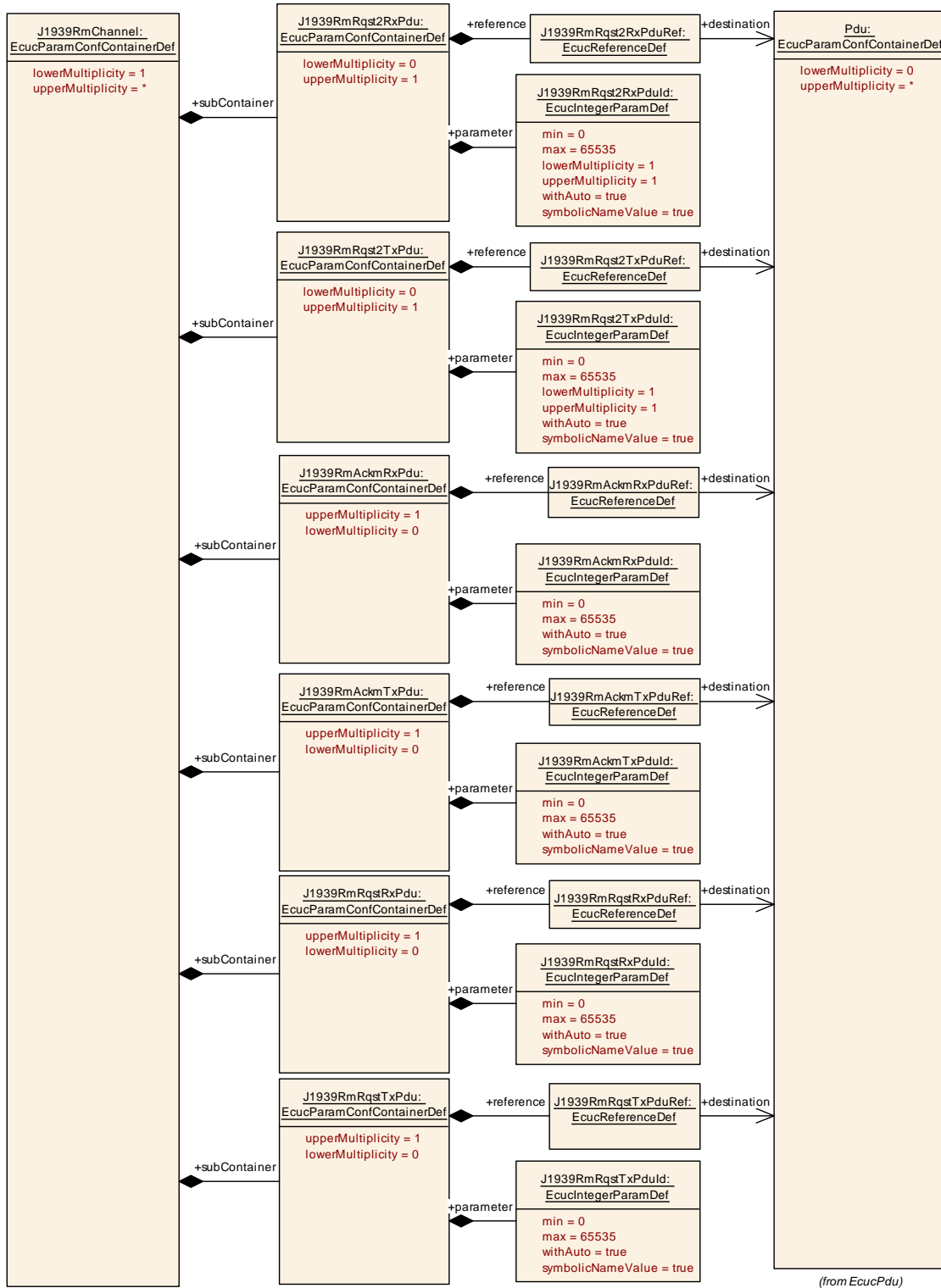

Figure 10.4: Configuration container J1939RmChannel with PDUs

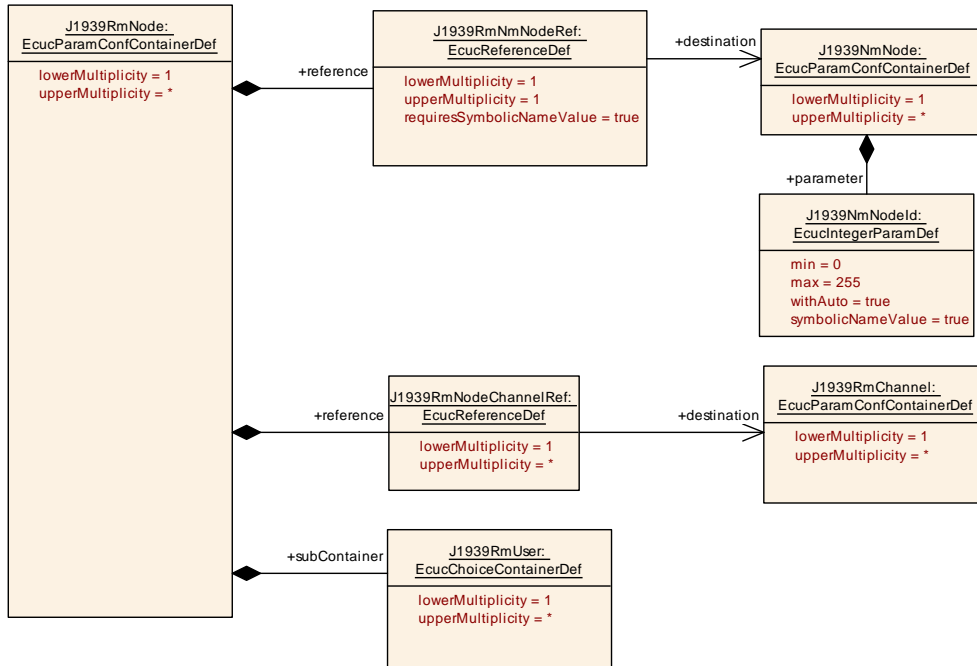

Figure 10.5: Configuration container J1939RmNode

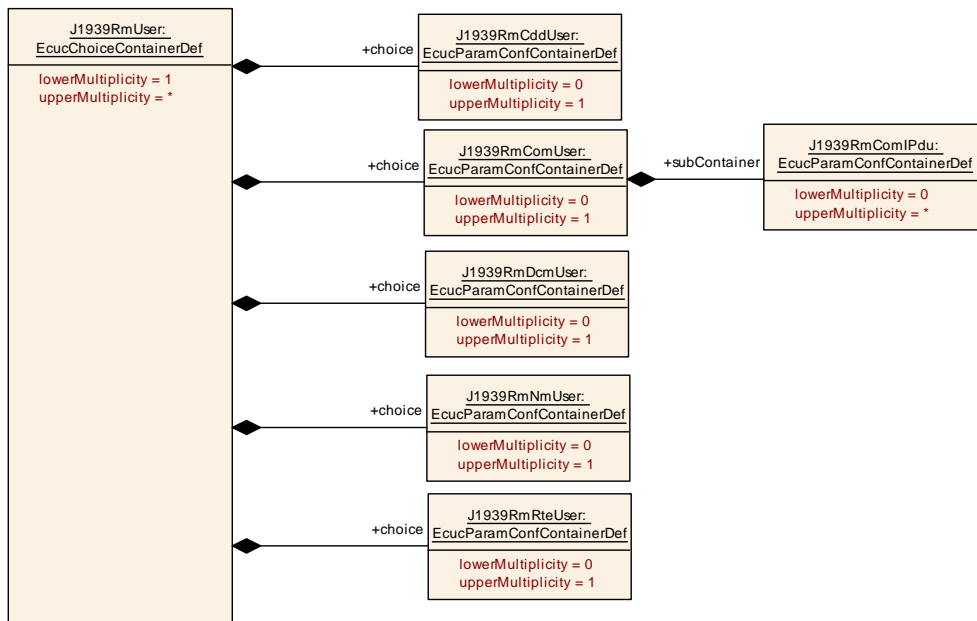

Figure 10.6: Configuration container J1939RmUser

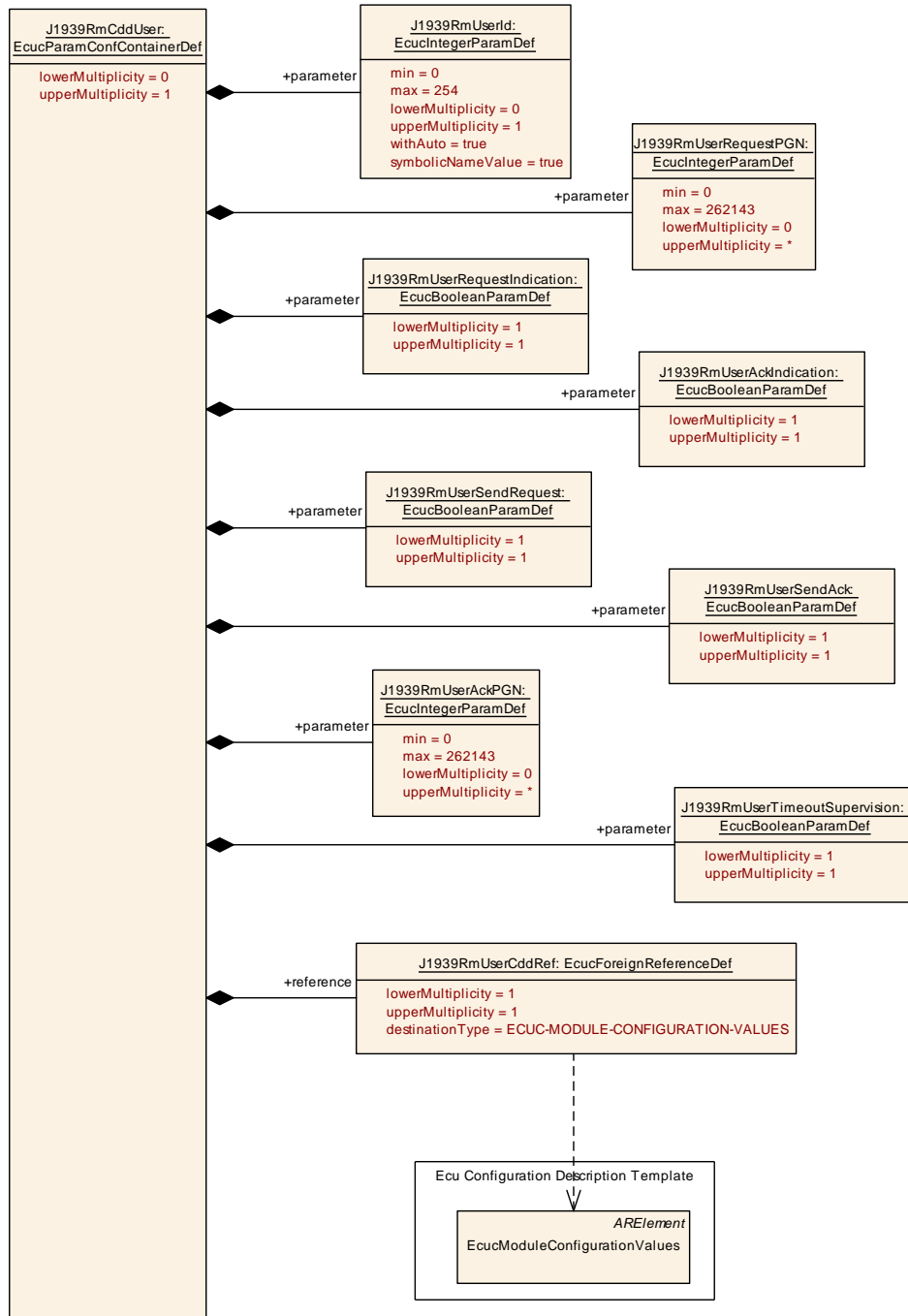

Figure 10.7: Configuration container J1939RmCddUser

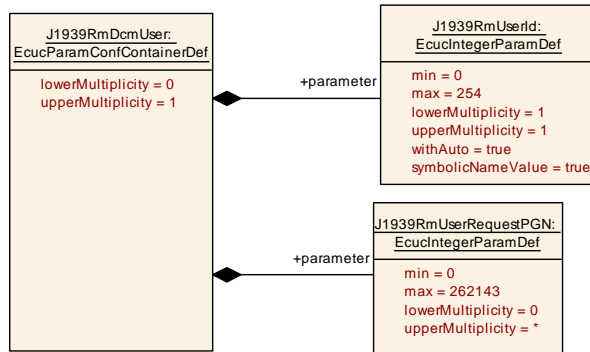

Figure 10.8: Configuration container J1939RmDcmUser

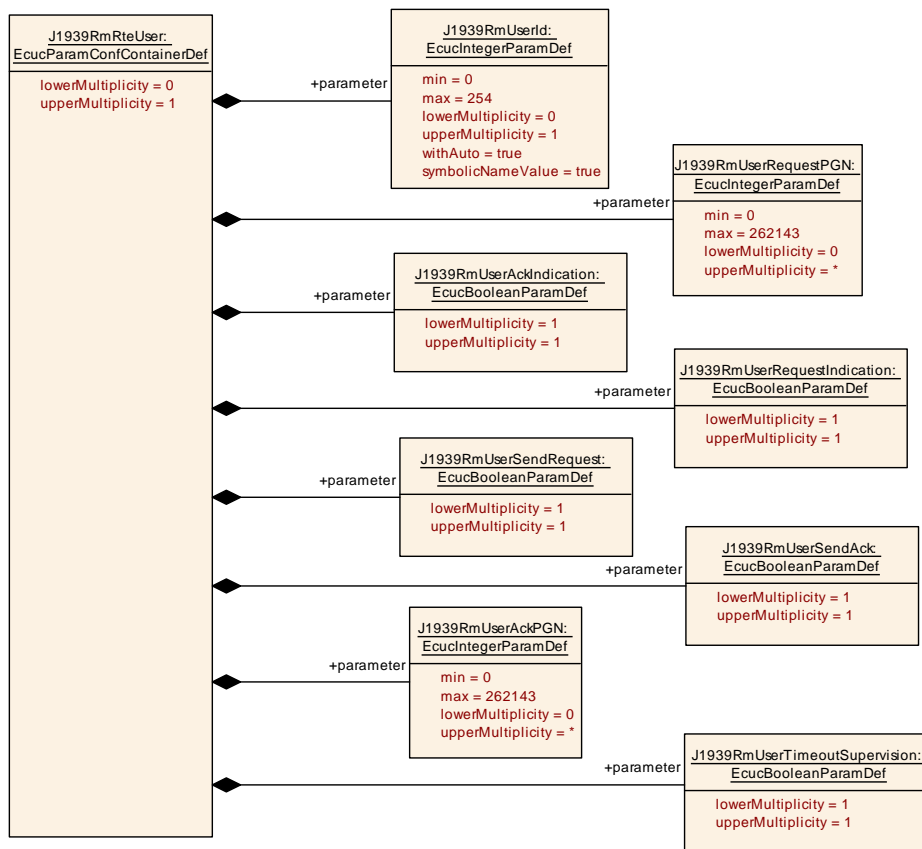

Figure 10.9: Configuration container J1939RmRteUser

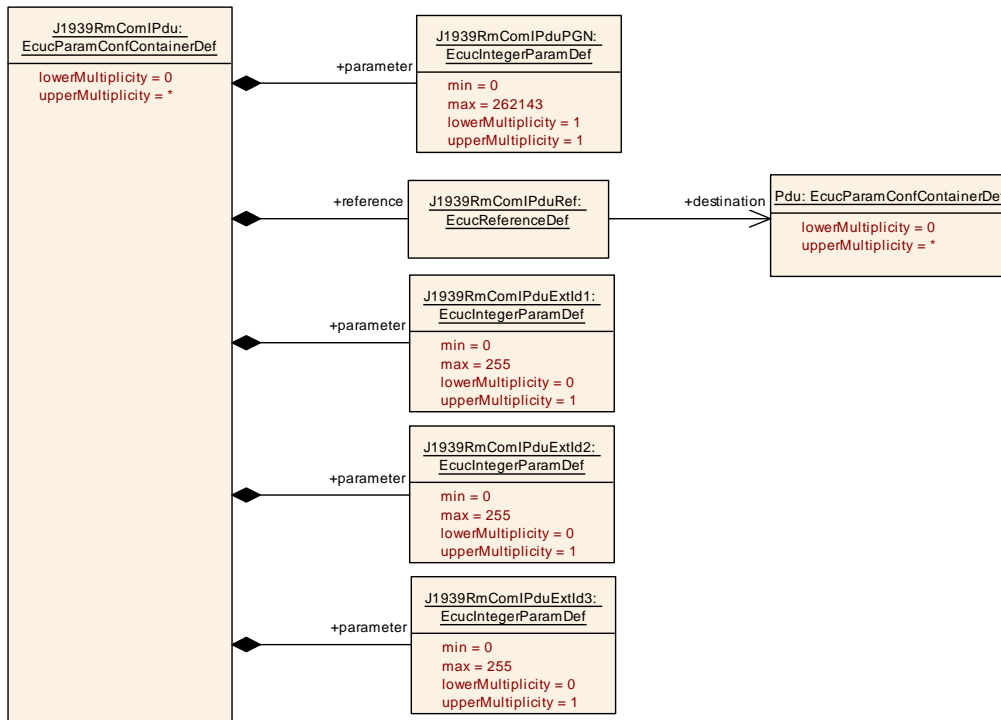

Figure 10.10: Configuration container J1939RmComIPdu

10.1.1 J1939Rm

SWS Item	[ECUC_J1939Rm_00043]
Module Name	J1939Rm
Description	Configuration of the J1939 Request Manager.
Post-Build Variant Support	true
Supported Config Variants	VARIANT-LINK-TIME, VARIANT-POST-BUILD, VARIANT-PRE-COMPILE

Included Containers		
Container Name	Multiplicity	Scope / Dependency
J1939RmConfigSet	1	This container contains the configuration parameters and sub containers of the AUTOSAR J1939Rm module.
J1939RmGeneral	1	Contains the general configuration parameters of the module.

10.1.2 J1939RmGeneral

SWS Item	[ECUC_J1939Rm_00001]
Container Name	J1939RmGeneral
Parent Container	J1939Rm
Description	Contains the general configuration parameters of the module.
Configuration Parameters	

SWS Item	[ECUC_J1939Rm_00003]		
Parameter Name	J1939RmDevErrorDetect		
Parent Container	J1939RmGeneral		
Description	Switches the development error detection and notification on or off. <ul style="list-style-type: none"> • true: detection and notification is enabled. • false: detection and notification is disabled. 		
Multiplicity	1		
Type	EcucBooleanParamDef		
Default value	false		
Post-Build Variant Value	false		
Value Configuration Class	Pre-compile time	X	All Variants
	Link time	–	
	Post-build time	–	
Scope / Dependency	scope: local		

SWS Item	[ECUC_J1939Rm_00084]		
Parameter Name	J1939RmGatewaySupport		
Parent Container	J1939RmGeneral		
Description	Enables/disables support for routing Request and Acknowledgement messages.		
Multiplicity	1		
Type	EcucBooleanParamDef		
Default value	–		
Post-Build Variant Value	false		
Value Configuration Class	Pre-compile time	X	All Variants
	Link time	–	
	Post-build time	–	
Scope / Dependency	scope: local		

SWS Item	[ECUC_J1939Rm_00004]		
Parameter Name	J1939RmMainFunctionPeriod		
Parent Container	J1939RmGeneral		
Description	Execution cycle of J1939Rm_MainFunction in seconds.		
Multiplicity	1		
Type	EcucFloatParamDef		
Range]0 .. INF[
Default value	–		
Post-Build Variant Value	false		
Value Configuration Class	Pre-compile time	X	VARIANT-PRE-COMPILE
	Link time	X	VARIANT-LINK-TIME, VARIANT-POST-BUILD
	Post-build time	–	
Scope / Dependency	scope: ECU		

SWS Item	[ECUC_J1939Rm_00054]		
Parameter Name	J1939RmSupportAckIndication		
Parent Container	J1939RmGeneral		
Description	Pre-processor switch for enabling support of acknowledgement indications.		





Multiplicity	1		
Type	EcucBooleanParamDef		
Default value	–		
Post-Build Variant Value	false		
Value Configuration Class	Pre-compile time	X	All Variants
	Link time	–	
	Post-build time	–	
Scope / Dependency	scope: local		

SWS Item	[ECUC_J1939Rm_00055]		
Parameter Name	J1939RmSupportAckTransmission		
Parent Container	J1939RmGeneral		
Description	Pre-processor switch for enabling support of acknowledgement transmission.		
Multiplicity	1		
Type	EcucBooleanParamDef		
Default value	–		
Post-Build Variant Value	false		
Value Configuration Class	Pre-compile time	X	All Variants
	Link time	–	
	Post-build time	–	
Scope / Dependency	scope: local		

SWS Item	[ECUC_J1939Rm_00073]		
Parameter Name	J1939RmSupportRequest2		
Parent Container	J1939RmGeneral		
Description	Pre-processor switch for enabling support of the Request2 PG. Please note: Transfer is not supported.		
Multiplicity	1		
Type	EcucBooleanParamDef		
Default value	–		
Post-Build Variant Value	false		
Value Configuration Class	Pre-compile time	X	All Variants
	Link time	–	
	Post-build time	–	
Scope / Dependency	scope: local		

SWS Item	[ECUC_J1939Rm_00056]		
Parameter Name	J1939RmSupportRequestIndication		
Parent Container	J1939RmGeneral		
Description	Pre-processor switch for enabling support of request indications.		
Multiplicity	1		
Type	EcucBooleanParamDef		
Default value	–		
Post-Build Variant Value	false		
Value Configuration Class	Pre-compile time	X	All Variants
	Link time	–	
	Post-build time	–	





Scope / Dependency	scope: local
---------------------------	--------------

SWS Item	[ECUC_J1939Rm_00057]		
Parameter Name	J1939RmSupportRequestTransmission		
Parent Container	J1939RmGeneral		
Description	Pre-processor switch for enabling support of request transmission.		
Multiplicity	1		
Type	EcucBooleanParamDef		
Default value	-		
Post-Build Variant Value	false		
Value Configuration Class	Pre-compile time	X	All Variants
	Link time	-	
	Post-build time	-	
Scope / Dependency	scope: local		

SWS Item	[ECUC_J1939Rm_00058]		
Parameter Name	J1939RmSupportTimeoutSupervision		
Parent Container	J1939RmGeneral		
Description	Pre-processor switch for enabling support of request timeout supervision.		
Multiplicity	1		
Type	EcucBooleanParamDef		
Default value	-		
Post-Build Variant Value	false		
Value Configuration Class	Pre-compile time	X	All Variants
	Link time	-	
	Post-build time	-	
Scope / Dependency	scope: local		

SWS Item	[ECUC_J1939Rm_00002]		
Parameter Name	J1939RmVersionInfoApi		
Parent Container	J1939RmGeneral		
Description	Pre-processor switch for enabling version info API support.		
Multiplicity	1		
Type	EcucBooleanParamDef		
Default value	false		
Post-Build Variant Value	false		
Value Configuration Class	Pre-compile time	X	All Variants
	Link time	-	
	Post-build time	-	
Scope / Dependency	scope: local		

No Included Containers

10.1.3 J1939RmConfigSet

SWS Item	[ECUC_J1939Rm_00017]
Container Name	J1939RmConfigSet
Parent Container	J1939Rm
Description	This container contains the configuration parameters and sub containers of the AUTOSAR J1939Rm module.
Configuration Parameters	

Included Containers		
Container Name	Multiplicity	Scope / Dependency
J1939RmChannel	1..*	Contains the parameters for a CAN channel supported by the J1939 Request Manager.
J1939RmNode	1..*	Contains the parameters for the support of a logical J1939 node (identified by an ECU address).

10.1.4 J1939RmChannel

SWS Item	[ECUC_J1939Rm_00009]		
Container Name	J1939RmChannel		
Parent Container	J1939RmConfigSet		
Description	Contains the parameters for a CAN channel supported by the J1939 Request Manager.		
Post-Build Variant Multiplicity	true		
Multiplicity Configuration Class	Pre-compile time	X	VARIANT-PRE-COMPILE
	Link time	X	VARIANT-LINK-TIME
	Post-build time	X	VARIANT-POST-BUILD
Configuration Parameters			

SWS Item	[ECUC_J1939Rm_00007]		
Parameter Name	J1939RmAckQueueSize		
Parent Container	J1939RmChannel		
Description	Number of transmitted Acknowledgement messages that can be stored.		
Multiplicity	1		
Type	EcucIntegerParamDef		
Range	0 .. 255		
Default value	-		
Post-Build Variant Value	false		
Value Configuration Class	Pre-compile time	X	VARIANT-PRE-COMPILE
	Link time	X	VARIANT-LINK-TIME, VARIANT-POST-BUILD
	Post-build time	-	
Scope / Dependency	scope: local		

SWS Item	[ECUC_J1939Rm_00074]		
Parameter Name	J1939RmRequest2QueueSize		
Parent Container	J1939RmChannel		





Description	Number of transmitted Request2 messages that can be stored.		
Multiplicity	1		
Type	EcucIntegerParamDef		
Range	0 .. 255		
Default value	–		
Post-Build Variant Value	false		
Value Configuration Class	Pre-compile time	X	VARIANT-PRE-COMPILE
	Link time	X	VARIANT-LINK-TIME, VARIANT-POST-BUILD
	Post-build time	–	
Scope / Dependency	scope: local		

SWS Item	[ECUC_J1939Rm_00006]		
Parameter Name	J1939RmRequestQueueSize		
Parent Container	J1939RmChannel		
Description	Number of transmitted Request messages that can be stored.		
Multiplicity	1		
Type	EcucIntegerParamDef		
Range	0 .. 255		
Default value	–		
Post-Build Variant Value	false		
Value Configuration Class	Pre-compile time	X	VARIANT-PRE-COMPILE
	Link time	X	VARIANT-LINK-TIME, VARIANT-POST-BUILD
	Post-build time	–	
Scope / Dependency	scope: local		

SWS Item	[ECUC_J1939Rm_00008]		
Parameter Name	J1939RmRequestTimeoutMonitors		
Parent Container	J1939RmChannel		
Description	Number of transmitted requests that can be monitored for timeout.		
Multiplicity	1		
Type	EcucIntegerParamDef		
Range	0 .. 255		
Default value	–		
Post-Build Variant Value	false		
Value Configuration Class	Pre-compile time	X	VARIANT-PRE-COMPILE
	Link time	X	VARIANT-LINK-TIME, VARIANT-POST-BUILD
	Post-build time	–	
Scope / Dependency	scope: local		

SWS Item	[ECUC_J1939Rm_00051]		
Parameter Name	J1939RmComMNetworkHandleRef		
Parent Container	J1939RmChannel		
Description	Reference to the channel defined by the ComMChannel providing access to the unique channel index ComMChannelId.		
Multiplicity	1		





Type	Symbolic name reference to ComMChannel		
Post-Build Variant Value	false		
Value Configuration Class	Pre-compile time	X	VARIANT-PRE-COMPILE
	Link time	X	VARIANT-LINK-TIME, VARIANT-POST-BUILD
	Post-build time	–	
Scope / Dependency	scope: local		

Included Containers		
Container Name	Multiplicity	Scope / Dependency
J1939RmAckmRxPdu	0..1	Contains the configuration of the I-PDU used to receive the Acknowledgement PG. This PDU consumes a meta data item of type CAN_ID_32.
J1939RmAckmTxPdu	0..1	Contains the configuration of the I-PDU used to transmit the Acknowledgement PG. This PDU produces a meta data item of type CAN_ID_32.
J1939RmRqst2RxPdu	0..1	Contains the configuration of the I-PDU used to receive the Request2 PG. This PDU consumes a meta data item of type CAN_ID_32.
J1939RmRqst2TxPdu	0..1	Contains the configuration of the I-PDU used to transmit the Request2 PG. This PDU produces a meta data item of type CAN_ID_32.
J1939RmRqstRxPdu	0..1	Contains the configuration of the I-PDU used to receive the Request PG. This PDU consumes a meta data item of type CAN_ID_32.
J1939RmRqstTxPdu	0..1	Contains the configuration of the I-PDU used to transmit the Request PG. This PDU produces a meta data item of type CAN_ID_32.

10.1.5 J1939RmAckmRxPdu

SWS Item	[ECUC_J1939Rm_00011]
Container Name	J1939RmAckmRxPdu
Parent Container	J1939RmChannel
Description	Contains the configuration of the I-PDU used to receive the Acknowledgement PG. This PDU consumes a meta data item of type CAN_ID_32.
Configuration Parameters	

SWS Item	[ECUC_J1939Rm_00015]		
Parameter Name	J1939RmAckmRxPduId		
Parent Container	J1939RmAckmRxPdu		
Description	The I-PDU identifier used for RxIndication from PduR.		
Multiplicity	1		
Type	EcucIntegerParamDef (Symbolic Name generated for this parameter)		
Range	0 .. 65535		
Default value	–		
Post-Build Variant Value	false		
Value Configuration Class	Pre-compile time	X	All Variants





	Link time	–	
	Post-build time	–	
Scope / Dependency	scope: ECU withAuto = true		

SWS Item	[ECUC_J1939Rm_00016]		
Parameter Name	J1939RmAckmRxPduRef		
Parent Container	J1939RmAckmRxPdu		
Description	Reference to the Pdu object representing the I-PDU.		
Multiplicity	1		
Type	Reference to Pdu		
Post-Build Variant Value	false		
Value Configuration Class	Pre-compile time	X	VARIANT-PRE-COMPILE
	Link time	X	VARIANT-LINK-TIME, VARIANT-POST-BUILD
	Post-build time	–	
Scope / Dependency	scope: local		

No Included Containers

10.1.6 J1939RmAckmTxPdu

SWS Item	[ECUC_J1939Rm_00012]		
Container Name	J1939RmAckmTxPdu		
Parent Container	J1939RmChannel		
Description	Contains the configuration of the I-PDU used to transmit the Acknowledgement PG. This PDU produces a meta data item of type CAN_ID_32.		
Configuration Parameters			

SWS Item	[ECUC_J1939Rm_00018]		
Parameter Name	J1939RmAckmTxPduId		
Parent Container	J1939RmAckmTxPdu		
Description	The I-PDU identifier used for TxConfirmation from PduR.		
Multiplicity	1		
Type	EcucIntegerParamDef (Symbolic Name generated for this parameter)		
Range	0 .. 65535		
Default value	–		
Post-Build Variant Value	false		
Value Configuration Class	Pre-compile time	X	All Variants
	Link time	–	
	Post-build time	–	
Scope / Dependency	scope: ECU withAuto = true		

SWS Item	[ECUC_J1939Rm_00019]		
Parameter Name	J1939RmAckmTxPduRef		
Parent Container	J1939RmAckmTxPdu		
Description	Reference to the Pdu object representing the I-PDU.		
Multiplicity	1		
Type	Reference to Pdu		
Post-Build Variant Value	false		
Value Configuration Class	Pre-compile time	X	VARIANT-PRE-COMPILE
	Link time	X	VARIANT-LINK-TIME, VARIANT-POST-BUILD
	Post-build time	–	
Scope / Dependency	scope: local		

No Included Containers

10.1.7 J1939RmRqstRxPdu

SWS Item	[ECUC_J1939Rm_00013]		
Container Name	J1939RmRqstRxPdu		
Parent Container	J1939RmChannel		
Description	Contains the configuration of the I-PDU used to receive the Request PG. This PDU consumes a meta data item of type CAN_ID_32.		
Configuration Parameters			

SWS Item	[ECUC_J1939Rm_00020]		
Parameter Name	J1939RmRqstRxPduld		
Parent Container	J1939RmRqstRxPdu		
Description	The I-PDU identifier used for RxIndication from PduR.		
Multiplicity	1		
Type	EcucIntegerParamDef (Symbolic Name generated for this parameter)		
Range	0 .. 65535		
Default value	–		
Post-Build Variant Value	false		
Value Configuration Class	Pre-compile time	X	All Variants
	Link time	–	
	Post-build time	–	
Scope / Dependency	scope: ECU withAuto = true		

SWS Item	[ECUC_J1939Rm_00021]		
Parameter Name	J1939RmRqstRxPduRef		
Parent Container	J1939RmRqstRxPdu		
Description	Reference to the Pdu object representing the I-PDU.		
Multiplicity	1		
Type	Reference to Pdu		





Post-Build Variant Value	false		
Value Configuration Class	Pre-compile time	X	VARIANT-PRE-COMPILE
	Link time	X	VARIANT-LINK-TIME, VARIANT-POST-BUILD
	Post-build time	–	
Scope / Dependency	scope: local		

No Included Containers

10.1.8 J1939RmRqstTxPdu

SWS Item	[ECUC_J1939Rm_00014]
Container Name	J1939RmRqstTxPdu
Parent Container	J1939RmChannel
Description	Contains the configuration of the I-PDU used to transmit the Request PG. This PDU produces a meta data item of type CAN_ID_32.
Configuration Parameters	

SWS Item	[ECUC_J1939Rm_00022]		
Parameter Name	J1939RmRqstTxPduId		
Parent Container	J1939RmRqstTxPdu		
Description	The I-PDU identifier used for TxConfirmation from PduR.		
Multiplicity	1		
Type	EcucIntegerParamDef (Symbolic Name generated for this parameter)		
Range	0 .. 65535		
Default value	–		
Post-Build Variant Value	false		
Value Configuration Class	Pre-compile time	X	All Variants
	Link time	–	
	Post-build time	–	
Scope / Dependency	scope: ECU withAuto = true		

SWS Item	[ECUC_J1939Rm_00023]		
Parameter Name	J1939RmRqstTxPduRef		
Parent Container	J1939RmRqstTxPdu		
Description	Reference to the Pdu object representing the I-PDU.		
Multiplicity	1		
Type	Reference to Pdu		
Post-Build Variant Value	false		
Value Configuration Class	Pre-compile time	X	VARIANT-PRE-COMPILE
	Link time	X	VARIANT-LINK-TIME, VARIANT-POST-BUILD
	Post-build time	–	
Scope / Dependency	scope: local		

No Included Containers

10.1.9 J1939RmRqst2RxPdu

SWS Item	[ECUC_J1939Rm_00075]
Container Name	J1939RmRqst2RxPdu
Parent Container	J1939RmChannel
Description	Contains the configuration of the I-PDU used to receive the Request2 PG. This PDU consumes a meta data item of type CAN_ID_32.
Configuration Parameters	

SWS Item	[ECUC_J1939Rm_00078]		
Parameter Name	J1939RmRqst2RxPduld		
Parent Container	J1939RmRqst2RxPdu		
Description	The I-PDU identifier used for RxIndication from PduR.		
Multiplicity	1		
Type	EcucIntegerParamDef (Symbolic Name generated for this parameter)		
Range	0 .. 65535		
Default value	–		
Post-Build Variant Value	false		
Value Configuration Class	Pre-compile time	X	All Variants
	Link time	–	
	Post-build time	–	
Scope / Dependency	scope: ECU withAuto = true		

SWS Item	[ECUC_J1939Rm_00077]		
Parameter Name	J1939RmRqst2RxPduRef		
Parent Container	J1939RmRqst2RxPdu		
Description	Reference to the Pdu object representing the I-PDU.		
Multiplicity	1		
Type	Reference to Pdu		
Post-Build Variant Value	false		
Value Configuration Class	Pre-compile time	X	VARIANT-PRE-COMPILE
	Link time	X	VARIANT-LINK-TIME, VARIANT-POST-BUILD
	Post-build time	–	
Scope / Dependency	scope: local		

No Included Containers

10.1.10 J1939RmRqst2TxPdu

SWS Item	[ECUC_J1939Rm_00076]
Container Name	J1939RmRqst2TxPdu
Parent Container	J1939RmChannel





Description	Contains the configuration of the I-PDU used to transmit the Request2 PG. This PDU produces a meta data item of type CAN_ID_32.
Configuration Parameters	

SWS Item	[ECUC_J1939Rm_00080]		
Parameter Name	J1939RmRqst2TxPduId		
Parent Container	J1939RmRqst2TxPdu		
Description	The I-PDU identifier used for TxConfirmation from PduR.		
Multiplicity	1		
Type	EcucIntegerParamDef (Symbolic Name generated for this parameter)		
Range	0 .. 65535		
Default value	-		
Post-Build Variant Value	false		
Value Configuration Class	Pre-compile time	X	All Variants
	Link time	-	
	Post-build time	-	
Scope / Dependency	scope: ECU withAuto = true		

SWS Item	[ECUC_J1939Rm_00079]		
Parameter Name	J1939RmRqst2TxPduRef		
Parent Container	J1939RmRqst2TxPdu		
Description	Reference to the Pdu object representing the I-PDU.		
Multiplicity	1		
Type	Reference to Pdu		
Post-Build Variant Value	false		
Value Configuration Class	Pre-compile time	X	VARIANT-PRE-COMPILE
	Link time	X	VARIANT-LINK-TIME, VARIANT-POST-BUILD
	Post-build time	-	
Scope / Dependency	scope: local		

No Included Containers

10.1.11 J1939RmNode

SWS Item	[ECUC_J1939Rm_00049]		
Container Name	J1939RmNode		
Parent Container	J1939RmConfigSet		
Description	Contains the parameters for the support of a logical J1939 node (identified by an ECU address).		
Post-Build Variant Multiplicity	true		
Multiplicity Configuration Class	Pre-compile time	X	VARIANT-PRE-COMPILE
	Link time	X	VARIANT-LINK-TIME
	Post-build time	X	VARIANT-POST-BUILD





Configuration Parameters			
--------------------------	--	--	--

SWS Item	[ECUC_J1939Rm_00005]		
Parameter Name	J1939RmNmNodeRef		
Parent Container	J1939RmNode		
Description	Reference to the corresponding J1939Nm node.		
Multiplicity	1		
Type	Symbolic name reference to J1939NmNode		
Post-Build Variant Value	false		
Value Configuration Class	Pre-compile time	X	VARIANT-PRE-COMPILE
	Link time	X	VARIANT-LINK-TIME, VARIANT-POST-BUILD
	Post-build time	–	
Scope / Dependency	scope: local		

SWS Item	[ECUC_J1939Rm_00052]		
Parameter Name	J1939RmNodeChannelRef		
Parent Container	J1939RmNode		
Description	Reference to the channels this node has access to.		
Multiplicity	1..*		
Type	Reference to J1939RmChannel		
Post-Build Variant Multiplicity	false		
Post-Build Variant Value	false		
Multiplicity Configuration Class	Pre-compile time	X	VARIANT-PRE-COMPILE
	Link time	X	VARIANT-LINK-TIME, VARIANT-POST-BUILD
	Post-build time	–	
Value Configuration Class	Pre-compile time	X	VARIANT-PRE-COMPILE
	Link time	X	VARIANT-LINK-TIME, VARIANT-POST-BUILD
	Post-build time	–	
Scope / Dependency	scope: local		

Included Containers		
Container Name	Multiplicity	Scope / Dependency
J1939RmUser	1..*	Contains the configuration of a module that uses the request and acknowledgement interfaces of J1939Rm.

10.1.12 J1939RmUser

SWS Item	[ECUC_J1939Rm_00010]
Choice Container Name	J1939RmUser
Parent Container	J1939RmNode
Description	Contains the configuration of a module that uses the request and acknowledgement interfaces of J1939Rm.
Post-Build Variant Multiplicity	true





Multiplicity Configuration Class	Pre-compile time	X	VARIANT-PRE-COMPILE
	Link time	X	VARIANT-LINK-TIME
	Post-build time	X	VARIANT-POST-BUILD

Container Choices		
Container Name	Multiplicity	Scope / Dependency
J1939RmCddUser	0..1	J1939Rm User representing a complex driver (CDD). CDDs may use all services provided by J1939Rm.
J1939RmComUser	0..1	J1939Rm User representing AUTOSAR COM. Supports requests for COM I-PDUs.
J1939RmDcmUser	0..1	J1939Rm User representing the J1939Dcm. Requires request indication and transmission of acknowledgement.
J1939RmNmUser	0..1	J1939Rm User representing the J1939Nm. Requires request indication.
J1939RmRteUser	0..1	J1939Rm User representing an application software component (SW-C). SW-Cs may use all services provided by the J1939Rm via service ports.

10.1.13 J1939RmNmUser

SWS Item	[ECUC_J1939Rm_00071]		
Container Name	J1939RmNmUser		
Parent Container	J1939RmUser		
Description	J1939Rm User representing the J1939Nm. Requires request indication.		
Post-Build Variant Multiplicity	true		
Multiplicity Configuration Class	Pre-compile time	X	VARIANT-PRE-COMPILE
	Link time	X	VARIANT-LINK-TIME
	Post-build time	X	VARIANT-POST-BUILD
Configuration Parameters			

No Included Containers

10.1.14 J1939RmDcmUser

SWS Item	[ECUC_J1939Rm_00068]		
Container Name	J1939RmDcmUser		
Parent Container	J1939RmUser		
Description	J1939Rm User representing the J1939Dcm. Requires request indication and transmission of acknowledgement.		
Post-Build Variant Multiplicity	true		
Multiplicity Configuration Class	Pre-compile time	X	VARIANT-PRE-COMPILE
	Link time	X	VARIANT-LINK-TIME
	Post-build time	X	VARIANT-POST-BUILD
Configuration Parameters			

SWS Item	[ECUC_J1939Rm_00072]		
Parameter Name	J1939RmUserId		
Parent Container	J1939RmDcmUser		
Description	Identifier used by J1939Dcm when calling J1939Rm_SendAck.		
Multiplicity	1		
Type	EcucIntegerParamDef (Symbolic Name generated for this parameter)		
Range	0 .. 254		
Default value	-		
Post-Build Variant Value	false		
Value Configuration Class	Pre-compile time	X	All Variants
	Link time	-	
	Post-build time	-	
Scope / Dependency	scope: ECU withAuto = true		

SWS Item	[ECUC_J1939Rm_00070]		
Parameter Name	J1939RmUserRequestPGN		
Parent Container	J1939RmDcmUser		
Description	PGN of DMx PG supported by J1939Dcm.		
Multiplicity	0..*		
Type	EcucIntegerParamDef		
Range	0 .. 262143		
Default value	-		
Post-Build Variant Multiplicity	true		
Post-Build Variant Value	true		
Multiplicity Configuration Class	Pre-compile time	X	VARIANT-PRE-COMPILE
	Link time	X	VARIANT-LINK-TIME
	Post-build time	X	VARIANT-POST-BUILD
Value Configuration Class	Pre-compile time	X	VARIANT-PRE-COMPILE
	Link time	X	VARIANT-LINK-TIME
	Post-build time	X	VARIANT-POST-BUILD
Scope / Dependency	scope: local		

No Included Containers

10.1.15 J1939RmCddUser

SWS Item	[ECUC_J1939Rm_00066]		
Container Name	J1939RmCddUser		
Parent Container	J1939RmUser		
Description	J1939Rm User representing a complex driver (CDD). CDDs may use all services provided by J1939Rm.		
Post-Build Variant Multiplicity	false		
Multiplicity Configuration Class	Pre-compile time	X	All Variants
	Link time	-	





	Post-build time	–	
Configuration Parameters			

SWS Item	[ECUC_J1939Rm_00028]		
Parameter Name	J1939RmUserAckIndication		
Parent Container	J1939RmCddUser		
Description	Enable AckIndication for this module. In case of CDD, the name is <apiServicePrefix>_AckIndication. In case of RTE, the operation AckIndication of the required port J1939Rm_AckIndication_{user} is called.		
Multiplicity	1		
Type	EcucBooleanParamDef		
Default value	–		
Post-Build Variant Value	false		
Value Configuration Class	Pre-compile time	X	All Variants
	Link time	–	
	Post-build time	–	
Scope / Dependency	scope: local		

SWS Item	[ECUC_J1939Rm_00061]		
Parameter Name	J1939RmUserAckPGN		
Parent Container	J1939RmCddUser		
Description	PGN supported to be acknowledged to this module. The PGNs supported by different modules should usually be disjunctive.		
Multiplicity	0..*		
Type	EcucIntegerParamDef		
Range	0 .. 262143		
Default value	–		
Post-Build Variant Multiplicity	false		
Post-Build Variant Value	false		
Multiplicity Configuration Class	Pre-compile time	X	All Variants
	Link time	–	
	Post-build time	–	
Value Configuration Class	Pre-compile time	X	All Variants
	Link time	–	
	Post-build time	–	
Scope / Dependency	scope: local		

SWS Item	[ECUC_J1939Rm_00025]		
Parameter Name	J1939RmUserId		
Parent Container	J1939RmCddUser		
Description	Identifier used by a module using J1939Rm. This parameter is only required when the module uses transmission of requests or acknowledgements.		
Multiplicity	0..1		
Type	EcucIntegerParamDef (Symbolic Name generated for this parameter)		
Range	0 .. 254		
Default value	–		
Post-Build Variant Multiplicity	false		
Post-Build Variant Value	false		





Multiplicity Configuration Class	Pre-compile time	X	All Variants
	Link time	–	
	Post-build time	–	
Value Configuration Class	Pre-compile time	X	All Variants
	Link time	–	
	Post-build time	–	
Scope / Dependency	scope: ECU withAuto = true		

SWS Item	[ECUC_J1939Rm_00027]		
Parameter Name	J1939RmUserRequestIndication		
Parent Container	J1939RmCddUser		
Description	Enable RequestIndication for this module. In case of J1939Nm or J1939Dcm, the name is fixed. In case of CDD, the name is <apiServicePrefix>_RequestIndication. In case of RTE, J1939Rm will call the operation RequestIndication of the required port J1939Rm_RequestIndication_{user}.		
Multiplicity	1		
Type	EcucBooleanParamDef		
Default value	–		
Post-Build Variant Value	false		
Value Configuration Class	Pre-compile time	X	All Variants
	Link time	–	
	Post-build time	–	
Scope / Dependency	scope: local		

SWS Item	[ECUC_J1939Rm_00026]		
Parameter Name	J1939RmUserRequestPGN		
Parent Container	J1939RmCddUser		
Description	PGN supported to be requested from this module. The PGNs supported by different modules should usually be disjunctive.		
Multiplicity	0..*		
Type	EcucIntegerParamDef		
Range	0 .. 262143		
Default value	–		
Post-Build Variant Multiplicity	false		
Post-Build Variant Value	false		
Multiplicity Configuration Class	Pre-compile time	X	All Variants
	Link time	–	
	Post-build time	–	
Value Configuration Class	Pre-compile time	X	All Variants
	Link time	–	
	Post-build time	–	
Scope / Dependency	scope: local		

SWS Item	[ECUC_J1939Rm_00030]		
Parameter Name	J1939RmUserSendAck		
Parent Container	J1939RmCddUser		





Description	Enable the SendAck API for this module. In case of RTE, the operation SendAck of the provided port J1939Rm_SendAck_{user} is called.		
Multiplicity	1		
Type	EcucBooleanParamDef		
Default value	-		
Post-Build Variant Value	false		
Value Configuration Class	Pre-compile time	X	All Variants
	Link time	-	
	Post-build time	-	
Scope / Dependency	scope: local		

SWS Item	[ECUC_J1939Rm_00029]		
Parameter Name	J1939RmUserSendRequest		
Parent Container	J1939RmCddUser		
Description	Enable the SendRequest API for this module. In case of RTE, the operation Send Request of the provided port J1939Rm_SendRequest_{user} is called.		
Multiplicity	1		
Type	EcucBooleanParamDef		
Default value	-		
Post-Build Variant Value	false		
Value Configuration Class	Pre-compile time	X	All Variants
	Link time	-	
	Post-build time	-	
Scope / Dependency	scope: local		

SWS Item	[ECUC_J1939Rm_00031]		
Parameter Name	J1939RmUserTimeoutSupervision		
Parent Container	J1939RmCddUser		
Description	<p>Enable RequestTimeoutIndication and CancelRequestTimeout for this module.</p> <p>RequestTimeoutIndication: In case of CDD, the name is <apiServicePrefix>_Request TimeoutIndication. In case of RTE, the operation RequestTimeoutIndication of the required port J1939Rm_RequestTimeoutIndication_{user} is called.</p> <p>CancelRequestTimeout: In case of RTE, the operation CancelRequestTimeout of the provided port J1939Rm_CancelRequestTimeout_{user} is called.</p>		
Multiplicity	1		
Type	EcucBooleanParamDef		
Default value	-		
Post-Build Variant Value	false		
Value Configuration Class	Pre-compile time	X	All Variants
	Link time	-	
	Post-build time	-	
Scope / Dependency	scope: local		

SWS Item	[ECUC_J1939Rm_00042]		
Parameter Name	J1939RmUserCddRef		
Parent Container	J1939RmCddUser		
Description	Reference to the CDD module description.		
Multiplicity	1		





Type	Foreign reference to ECUC-MODULE-CONFIGURATION-VALUES		
Post-Build Variant Value	false		
Value Configuration Class	Pre-compile time	X	All Variants
	Link time	–	
	Post-build time	–	
Scope / Dependency	scope: local		

No Included Containers

10.1.16 J1939RmRteUser

SWS Item	[ECUC_J1939Rm_00069]		
Container Name	J1939RmRteUser		
Parent Container	J1939RmUser		
Description	J1939Rm User representing an application software component (SW-C). SW-Cs may use all services provided by the J1939Rm via service ports.		
Post-Build Variant Multiplicity	false		
Multiplicity Configuration Class	Pre-compile time	X	All Variants
	Link time	–	
	Post-build time	–	
Configuration Parameters			

SWS Item	[ECUC_J1939Rm_00028]		
Parameter Name	J1939RmUserAckIndication		
Parent Container	J1939RmRteUser		
Description	Enable AckIndication for this module. In case of CDD, the name is <apiServicePrefix>_AckIndication. In case of RTE, the operation AckIndication of the required port J1939Rm_AckIndication_{user} is called.		
Multiplicity	1		
Type	EcucBooleanParamDef		
Default value	–		
Post-Build Variant Value	false		
Value Configuration Class	Pre-compile time	X	All Variants
	Link time	–	
	Post-build time	–	
Scope / Dependency	scope: local		

SWS Item	[ECUC_J1939Rm_00061]		
Parameter Name	J1939RmUserAckPGN		
Parent Container	J1939RmRteUser		
Description	PGN supported to be acknowledged to this module. The PGNs supported by different modules should usually be disjunctive.		
Multiplicity	0..*		
Type	EcucIntegerParamDef		
Range	0 .. 262143		





Default value	–		
Post-Build Variant Multiplicity	false		
Post-Build Variant Value	false		
Multiplicity Configuration Class	Pre-compile time	X	All Variants
	Link time	–	
	Post-build time	–	
Value Configuration Class	Pre-compile time	X	All Variants
	Link time	–	
	Post-build time	–	
Scope / Dependency	scope: local		

SWS Item	[ECUC_J1939Rm_00025]		
Parameter Name	J1939RmUserId		
Parent Container	J1939RmRteUser		
Description	Identifier used by a module using J1939Rm. This parameter is only required when the module uses transmission of requests or acknowledgements.		
Multiplicity	0..1		
Type	EcucIntegerParamDef (Symbolic Name generated for this parameter)		
Range	0 .. 254		
Default value	–		
Post-Build Variant Multiplicity	false		
Post-Build Variant Value	false		
Multiplicity Configuration Class	Pre-compile time	X	All Variants
	Link time	–	
	Post-build time	–	
Value Configuration Class	Pre-compile time	X	All Variants
	Link time	–	
	Post-build time	–	
Scope / Dependency	scope: ECU withAuto = true		

SWS Item	[ECUC_J1939Rm_00027]		
Parameter Name	J1939RmUserRequestIndication		
Parent Container	J1939RmRteUser		
Description	Enable RequestIndication for this module. In case of J1939Nm or J1939Dcm, the name is fixed. In case of CDD, the name is <apiServicePrefix>_RequestIndication. In case of RTE, J1939Rm will call the operation RequestIndication of the required port J1939Rm_RequestIndication_{user}.		
Multiplicity	1		
Type	EcucBooleanParamDef		
Default value	–		
Post-Build Variant Value	false		
Value Configuration Class	Pre-compile time	X	All Variants
	Link time	–	
	Post-build time	–	
Scope / Dependency	scope: local		

SWS Item	[ECUC_J1939Rm_00026]		
Parameter Name	J1939RmUserRequestPGN		
Parent Container	J1939RmRteUser		
Description	PGN supported to be requested from this module. The PGNs supported by different modules should usually be disjunctive.		
Multiplicity	0..*		
Type	EcucIntegerParamDef		
Range	0 .. 262143		
Default value	–		
Post-Build Variant Multiplicity	false		
Post-Build Variant Value	false		
Multiplicity Configuration Class	Pre-compile time	X	All Variants
	Link time	–	
	Post-build time	–	
Value Configuration Class	Pre-compile time	X	All Variants
	Link time	–	
	Post-build time	–	
Scope / Dependency	scope: local		

SWS Item	[ECUC_J1939Rm_00030]		
Parameter Name	J1939RmUserSendAck		
Parent Container	J1939RmRteUser		
Description	Enable the SendAck API for this module. In case of RTE, the operation SendAck of the provided port J1939Rm_SendAck_{user} is called.		
Multiplicity	1		
Type	EcucBooleanParamDef		
Default value	–		
Post-Build Variant Value	false		
Value Configuration Class	Pre-compile time	X	All Variants
	Link time	–	
	Post-build time	–	
Scope / Dependency	scope: local		

SWS Item	[ECUC_J1939Rm_00029]		
Parameter Name	J1939RmUserSendRequest		
Parent Container	J1939RmRteUser		
Description	Enable the SendRequest API for this module. In case of RTE, the operation Send Request of the provided port J1939Rm_SendRequest_{user} is called.		
Multiplicity	1		
Type	EcucBooleanParamDef		
Default value	–		
Post-Build Variant Value	false		
Value Configuration Class	Pre-compile time	X	All Variants
	Link time	–	
	Post-build time	–	
Scope / Dependency	scope: local		

SWS Item	[ECUC_J1939Rm_00031]		
Parameter Name	J1939RmUserTimeoutSupervision		
Parent Container	J1939RmRteUser		
Description	<p>Enable RequestTimeoutIndication and CancelRequestTimeout for this module.</p> <p>RequestTimeoutIndication: In case of CDD, the name is <apiServicePrefix>_RequestTimeoutIndication. In case of RTE, the operation RequestTimeoutIndication of the required port J1939Rm_RequestTimeoutIndication_{user} is called.</p> <p>CancelRequestTimeout: In case of RTE, the operation CancelRequestTimeout of the provided port J1939Rm_CancelRequestTimeout_{user} is called.</p>		
Multiplicity	1		
Type	EcucBooleanParamDef		
Default value	-		
Post-Build Variant Value	false		
Value Configuration Class	Pre-compile time	X	All Variants
	Link time	-	
	Post-build time	-	
Scope / Dependency	scope: local		

No Included Containers

10.1.17 J1939RmComUser

SWS Item	[ECUC_J1939Rm_00067]		
Container Name	J1939RmComUser		
Parent Container	J1939RmUser		
Description	J1939Rm User representing AUTOSAR COM. Supports requests for COM I-PDUs.		
Post-Build Variant Multiplicity	true		
Multiplicity Configuration Class	Pre-compile time	X	VARIANT-PRE-COMPILE
	Link time	X	VARIANT-LINK-TIME
	Post-build time	X	VARIANT-POST-BUILD
Configuration Parameters			

Included Containers		
Container Name	Multiplicity	Scope / Dependency
J1939RmComIPdu	0..*	Contains the configuration of an I-PDU that is to be transmitted on request by COM.

10.1.18 J1939RmComIPdu

SWS Item	[ECUC_J1939Rm_00032]		
Container Name	J1939RmComIPdu		
Parent Container	J1939RmComUser		
Description	Contains the configuration of an I-PDU that is to be transmitted on request by COM.		





Post-Build Variant Multiplicity	true		
Multiplicity Configuration Class	Pre-compile time	X	VARIANT-PRE-COMPILE
	Link time	X	VARIANT-LINK-TIME
	Post-build time	X	VARIANT-POST-BUILD
Configuration Parameters			

SWS Item	[ECUC_J1939Rm_00081]		
Parameter Name	J1939RmComIPduExtId1		
Parent Container	J1939RmComIPdu		
Description	First extended identifier byte of the COM I-PDU.		
Multiplicity	0..1		
Type	EcucIntegerParamDef		
Range	0 .. 255		
Default value	-		
Post-Build Variant Multiplicity	true		
Post-Build Variant Value	true		
Multiplicity Configuration Class	Pre-compile time	X	VARIANT-PRE-COMPILE
	Link time	X	VARIANT-LINK-TIME
	Post-build time	X	VARIANT-POST-BUILD
Value Configuration Class	Pre-compile time	X	VARIANT-PRE-COMPILE
	Link time	X	VARIANT-LINK-TIME
	Post-build time	X	VARIANT-POST-BUILD
Scope / Dependency	scope: local		

SWS Item	[ECUC_J1939Rm_00082]		
Parameter Name	J1939RmComIPduExtId2		
Parent Container	J1939RmComIPdu		
Description	Second extended identifier byte of the COM I-PDU.		
Multiplicity	0..1		
Type	EcucIntegerParamDef		
Range	0 .. 255		
Default value	-		
Post-Build Variant Multiplicity	true		
Post-Build Variant Value	true		
Multiplicity Configuration Class	Pre-compile time	X	VARIANT-PRE-COMPILE
	Link time	X	VARIANT-LINK-TIME
	Post-build time	X	VARIANT-POST-BUILD
Value Configuration Class	Pre-compile time	X	VARIANT-PRE-COMPILE
	Link time	X	VARIANT-LINK-TIME
	Post-build time	X	VARIANT-POST-BUILD
Scope / Dependency	scope: local		

SWS Item	[ECUC_J1939Rm_00083]		
Parameter Name	J1939RmComIPduExtId3		
Parent Container	J1939RmComIPdu		
Description	Third extended identifier byte of the COM I-PDU.		
Multiplicity	0..1		





Type	EcucIntegerParamDef		
Range	0 .. 255		
Default value	–		
Post-Build Variant Multiplicity	true		
Post-Build Variant Value	true		
Multiplicity Configuration Class	Pre-compile time	X	VARIANT-PRE-COMPILE
	Link time	X	VARIANT-LINK-TIME
	Post-build time	X	VARIANT-POST-BUILD
Value Configuration Class	Pre-compile time	X	VARIANT-PRE-COMPILE
	Link time	X	VARIANT-LINK-TIME
	Post-build time	X	VARIANT-POST-BUILD
Scope / Dependency	scope: local		

SWS Item	[ECUC_J1939Rm_00033]		
Parameter Name	J1939RmComIPduPGN		
Parent Container	J1939RmComIPdu		
Description	PGN of the COM I-PDU.		
Multiplicity	1		
Type	EcucIntegerParamDef		
Range	0 .. 262143		
Default value	–		
Post-Build Variant Value	true		
Value Configuration Class	Pre-compile time	X	VARIANT-PRE-COMPILE
	Link time	X	VARIANT-LINK-TIME
	Post-build time	X	VARIANT-POST-BUILD
Scope / Dependency	scope: local		

SWS Item	[ECUC_J1939Rm_00065]		
Parameter Name	J1939RmComIPduRef		
Parent Container	J1939RmComIPdu		
Description	Reference to the Pdu object representing the I-PDU.		
Multiplicity	1		
Type	Reference to Pdu		
Post-Build Variant Value	false		
Value Configuration Class	Pre-compile time	X	VARIANT-PRE-COMPILE
	Link time	X	VARIANT-LINK-TIME
	Post-build time	X	VARIANT-POST-BUILD
Scope / Dependency	scope: local		

No Included Containers

10.2 Published Information

For details refer to the chapter 10.3 “Published Information” [4, SWS BSW General].

A History of Constraints and Specification Items

Please note that the lists in this chapter also include constraints and specification items that have been removed from the specification in a later version. These constraints and specification items do not appear as hyperlinks in the document.

A.1 Constraint and Specification Item History of this Document According to AUTOSAR Release R21-11

A.1.1 Added Specification Items in R21-11

none

A.1.2 Changed Specification Items in R21-11

[\[SWS_J1939Rm_00033\]](#) [\[SWS_J1939Rm_00118\]](#) [\[SWS_J1939Rm_00124\]](#) [\[SWS_J1939Rm_00127\]](#) [\[SWS_J1939Rm_00128\]](#) [\[SWS_J1939Rm_00129\]](#)

A.1.3 Deleted Specification Items in R21-11

none

A.2 Constraint and Specification Item History of this Document According to AUTOSAR Release R22-11

A.2.1 Added Specification Items in R22-11

[\[SWS_J1939Rm_NA\]](#)

A.2.2 Changed Specification Items in R22-11

none

A.2.3 Deleted Specification Items in R22-11

none

A.3 Constraint and Specification Item History of this Document According to AUTOSAR Release R23-11

A.3.1 Added Specification Items in R23-11

none

A.3.2 Changed Specification Items in R23-11

[\[SWS_J1939Rm_00029\]](#) [\[SWS_J1939Rm_00055\]](#) [\[SWS_J1939Rm_00057\]](#) [\[SWS_J1939Rm_00063\]](#) [\[SWS_J1939Rm_00064\]](#) [\[SWS_J1939Rm_00065\]](#) [\[SWS_J1939Rm_00105\]](#) [\[SWS_J1939Rm_00118\]](#) [\[SWS_J1939Rm_91000\]](#)

A.3.3 Deleted Specification Items in R23-11

none

B Not Applicable Requirements

[SWS_J1939Rm_NA] [These requirements are not applicable to this specification.] (*SRS_J1939_00001, SRS_J1939_00002, SRS_J1939_00003, SRS_J1939_00004, SRS_J1939_00006, SRS_J1939_00010, SRS_J1939_00011, SRS_J1939_00018, SRS_J1939_00019, SRS_J1939_00020, SRS_J1939_00021, SRS_J1939_00022, SRS_J1939_00023, SRS_J1939_00024, SRS_J1939_00025, SRS_J1939_00027, SRS_J1939_00028, SRS_J1939_00029, SRS_J1939_00030, SRS_J1939_00031, SRS_J1939_00032, SRS_J1939_00033, SRS_J1939_00034, SRS_J1939_00035, SRS_J1939_00036, SRS_J1939_00037, SRS_J1939_00038, SRS_J1939_00039, SRS_J1939_00040, SRS_J1939_00041, SRS_J1939_00042, SRS_J1939_00043, SRS_J1939_00044, SRS_J1939_00045, SRS_J1939_00046, SRS_J1939_00047, SRS_J1939_00048, SRS_J1939_00051, SRS_J1939_NA*)