

|                                   |                             |
|-----------------------------------|-----------------------------|
| <b>Document Title</b>             | Specification of PWM Driver |
| <b>Document Owner</b>             | AUTOSAR                     |
| <b>Document Responsibility</b>    | AUTOSAR                     |
| <b>Document Identification No</b> | 37                          |
| <b>Document Status</b>            | published                   |
| <b>Part of AUTOSAR Standard</b>   | Classic Platform            |
| <b>Part of Standard Release</b>   | R23-11                      |

| <b>Document Change History</b> |                |                                  |   |
|--------------------------------|----------------|----------------------------------|---|
| <b>Date</b>                    | <b>Release</b> | <b>Changed by</b>                | <b>Change Description</b>   |
| 2023-11-23                     | R23-11         | AUTOSAR<br>Release<br>Management | <ul style="list-style-type: none"> <li>No content changes</li> </ul>  |
| 2022-11-24                     | R22-11         | AUTOSAR<br>Release<br>Management | <ul style="list-style-type: none"> <li>Changed ID from SWS_Pwm_00153 to SWS_Pwm_NA_00153</li> </ul>   |
| 2021-11-25                     | R21-11         | AUTOSAR<br>Release<br>Management | <ul style="list-style-type: none"> <li>SWS_Pwm_00061 removed as &lt;Modul&gt;_ConfigTypes are introduced as implementation specific and therefore additional requirements did not make sense anymore</li> <li>Runtime error added on SWS_Pwm_00200</li> </ul> |
| 2020-11-30                     | R20-11         | AUTOSAR<br>Release<br>Management | <ul style="list-style-type: none"> <li>Minor corrections in section Error Classification</li> </ul>   |
| 2019-11-28                     | R19-11         | AUTOSAR<br>Release<br>Management | <ul style="list-style-type: none"> <li>Introduced MCAL Multicore Distribution</li> <li>Changed Document Status from Final to published</li> </ul>   |
| 2018-10-31                     | 4.4.0          | AUTOSAR<br>Release<br>Management | <ul style="list-style-type: none"> <li>Incorporated concept MCAL Multicore Distribution (Draft)</li> <li>Removal of obsolete elements</li> <li>Header File Cleanup</li> <li>Fixed document structure for automated document processing</li> </ul>             |

| Document Change History |         |                            |  |
|-------------------------|---------|----------------------------|--|
| Date                    | Release | Changed by                 | Change Description   |
| 2017-12-08              | 4.3.1   | AUTOSAR Release Management | <ul style="list-style-type: none"> <li>Added classification for Runtime error</li> <li>Removed SWS_Pwm_20069, SWS_Pwm_10120 and SWS_Pwm_20120</li> </ul>   |
| 2016-11-30              | 4.3.0   | AUTOSAR Release Management | <ul style="list-style-type: none"> <li>Updated Pwm_GetOutputState return value requirement SWS_Pwm_30051 and its references</li> <li>Updated Configuration Class for PwmChannelID</li> <li>Removed definition of Configuration variants</li> <li>Removed Unresolved References of BSW requirements</li> <li>Updated Header file structure diagram</li> </ul> |
| 2015-07-31              | 4.2.2   | AUTOSAR Release Management | <ul style="list-style-type: none"> <li>Removed requirements with respect to NULL_PTR check</li> <li>DET has been renamed</li> </ul>  |
| 2014-10-31              | 4.2.1   | AUTOSAR Release Management | <ul style="list-style-type: none"> <li>Updated trace reference for code file structure requirement</li> </ul>  |
| 2014-03-31              | 4.1.3   | AUTOSAR Release Management | <ul style="list-style-type: none"> <li>Introduction of McuClockReferencePoint</li> <li>Editorial changes</li> </ul>  |
| 2013-10-31              | 4.1.2   | AUTOSAR Release Management | <ul style="list-style-type: none"> <li>Updated requirements related to PwmPowerStateAsynchTransitionMode</li> <li>Updated Scheduled Functions chapter</li> <li>Editorial changes</li> <li>Removed chapter(s) on change documentation</li> </ul>  |
| 2013-03-15              | 4.1.1   | AUTOSAR Administration     | <ul style="list-style-type: none"> <li>Added ECU degradation concept</li> <li>Adapted to new SWS BSW General</li> <li>Split memory map header</li> </ul>   |
| 2011-12-22              | 4.0.3   | AUTOSAR Administration     | <ul style="list-style-type: none"> <li>Re-formulated SWS_Pwm_00045</li> </ul>  |

| Document Change History |         |                        |  |
|-------------------------|---------|------------------------|--|
| Date                    | Release | Changed by             | Change Description   |
| 2010-09-30              | 3.1.5   | AUTOSAR Administration | <ul style="list-style-type: none"> <li>• New Error symbol: PWM_E_PARAM_POINTER, shall be reported if API Pwm_GetVersionInfo service is called with a NULL parameter</li> <li>• Updated the chapter Version Check</li> <li>• Maintenance in phrasing and explaining</li> </ul>  |
| 2010-02-02              | 3.1.4   | AUTOSAR Administration | <ul style="list-style-type: none"> <li>• The behavior of the function Pwm_SetPeriodAndDuty is explained in case of an input value of zero period.</li> <li>• Added the chapter Debug Support</li> <li>• Splitted some requirements so each ID is unique.</li> <li>• Legal disclaimer revised</li> </ul>  |
| 2008-08-13              | 3.1.1   | AUTOSAR Administration | <ul style="list-style-type: none"> <li>• Legal disclaimer revised</li> </ul>   |
| 2007-12-21              | 3.0.1   | AUTOSAR Administration | <ul style="list-style-type: none"> <li>• Tables generated from UML-models and UML-diagrams linked to UML-model</li> <li>• General improvements of requirements in preparation of CT-development</li> <li>• Reactivation concept for IDLE PWM channels adapted</li> <li>• Development error in case of already initialized module added</li> <li>• Document meta information extended</li> <li>• Small layout adaptations made</li> </ul> |

| <b>Document Change History</b> |                |                        |  |
|--------------------------------|----------------|------------------------|--|
| <b>Date</b>                    | <b>Release</b> | <b>Changed by</b>      | <b>Change Description</b>  |
| 2007-01-24                     | 2.1.15         | AUTOSAR Administration | <ul style="list-style-type: none"> <li>• Updated file include structure</li> <li>• Added configuration macros ON/OFF for PWM APIs</li> <li>• Renamed configuration parameter PWM_PERIOD_UPDATED_ENDPERIOD to PwmPeriodUpdatedEndperiod</li> <li>• Updated PWM signal description figure</li> <li>• Legal disclaimer revised</li> <li>• “Advice for users” revised</li> <li>• “Revision Information” added</li> </ul> |
| 2006-05-16                     | 2.0            | AUTOSAR Administration | <ul style="list-style-type: none"> <li>• Document structure adapted to common Release 2.0 SWS Template.</li> <li>• Modify abstraction level of PWM channel</li> <li>• Notifications are configurable</li> <li>• Update the configuration of the module</li> </ul>  |
| 2005-05-31                     | 1.0            | AUTOSAR Administration | <ul style="list-style-type: none"> <li>• Initial Release</li> </ul>  |

## Disclaimer

This work (specification and/or software implementation) and the material contained in it, as released by AUTOSAR, is for the purpose of information only. AUTOSAR and the companies that have contributed to it shall not be liable for any use of the work.

The material contained in this work is protected by copyright and other types of intellectual property rights. The commercial exploitation of the material contained in this work requires a license to such intellectual property rights.

This work may be utilized or reproduced without any modification, in any form or by any means, for informational purposes only. For any other purpose, no part of the work may be utilized or reproduced, in any form or by any means, without permission in writing from the publisher.

The work has been developed for automotive applications only. It has neither been developed, nor tested for non-automotive applications.

The word AUTOSAR and the AUTOSAR logo are registered trademarks.

## Table of Contents

|       |   |    |
|-------|---|----|
| 1     | Introduction and functional overview .....          | 8  |
| 2     | Acronyms and abbreviations.....                     | 9  |
| 3     | Related documentation .....                         | 10 |
| 3.1   | Input documents.....                                | 10 |
| 3.2   | Related specification.....                          | 10 |
| 4     | Constraints and assumptions.....                    | 11 |
| 4.1   | Limitations .....                                   | 11 |
| 4.2   | Applicability to car domains .....                  | 11 |
| 5     | Dependencies to other modules .....                 | 12 |
| 5.1   | File structure .....                                | 12 |
| 5.1.1 | Code file structure .....                           | 12 |
| 5.1.2 | Header file structure .....                         | 12 |
| 6     | Requirements traceability .....                     | 13 |
| 7     | Functional specification.....                       | 15 |
| 7.1   | General behavior.....                               | 15 |
| 7.2   | Time Unit Ticks .....                               | 15 |
| 7.2.1 | Background & Rationale .....                        | 15 |
| 7.2.2 | Requirements .....                                  | 15 |
| 7.3   | Support and management of HW low power states ..... | 15 |
| 7.3.1 | Background .....                                    | 15 |
| 7.3.2 | Requirements .....                                  | 16 |
| 7.4   | Duty Cycle Resolution and scaling .....             | 17 |
| 7.5   | Version check.....                                  | 18 |
| 7.6   | Error classification.....                           | 18 |
| 7.6.1 | Development Errors .....                            | 18 |
| 7.6.2 | Runtime Errors .....                                | 19 |
| 7.6.3 | Transient Faults.....                               | 20 |
| 7.6.4 | Production Errors .....                             | 20 |
| 7.6.5 | Extended Production Errors .....                    | 20 |
| 8     | API specification.....                              | 21 |
| 8.1   | Imported types .....                                | 21 |
| 8.2   | Type definitions .....                              | 21 |
| 8.2.1 | Pwm_ChannelType .....                               | 21 |
| 8.2.2 | Pwm_PeriodType .....                                | 21 |
| 8.2.3 | Pwm_OutputStateType .....                           | 22 |
| 8.2.4 | Pwm_EdgeNotificationType .....                      | 22 |
| 8.2.5 | Pwm_ChannelClassType .....                          | 22 |
| 8.2.6 | Pwm_ConfigType .....                                | 23 |
| 8.2.7 | Pwm_PowerStateRequestResultType .....               | 23 |
| 8.2.8 | Pwm_PowerStateType.....                             | 24 |
| 8.3   | Function definitions .....                          | 24 |

|        |  |    |
|--------|--|----|
| 8.3.1  | Pwm_Init.....                                | 24 |
| 8.3.2  | Pwm_DeInit.....                              | 26 |
| 8.3.3  | Pwm_SetDutyCycle.....                        | 27 |
| 8.3.4  | Pwm_SetPeriodAndDuty.....                    | 28 |
| 8.3.5  | Pwm_SetOutputTogle.....                      | 29 |
| 8.3.6  | Pwm_GetOutputState.....                      | 31 |
| 8.3.7  | Pwm_DisableNotification.....                 | 32 |
| 8.3.8  | Pwm_EnableNotification.....                  | 33 |
| 8.3.9  | Pwm_SetPowerState.....                       | 34 |
| 8.3.10 | Pwm_GetCurrentPowerState.....                | 36 |
| 8.3.11 | Pwm_GetTargetPowerState.....                 | 37 |
| 8.3.12 | Pwm_PreparePowerState.....                   | 38 |
| 8.3.13 | Pwm_GetVersionInfo.....                      | 39 |
| 8.4    | Callback notifications.....                  | 40 |
| 8.5    | Scheduled functions.....                     | 40 |
| 8.5.1  | Pwm_Main_PowerTransitionManager.....         | 40 |
| 8.6    | Expected Interfaces.....                     | 41 |
| 8.6.1  | Mandatory Interfaces.....                    | 41 |
| 8.6.2  | Optional Interfaces.....                     | 41 |
| 8.6.3  | Configurable interfaces.....                 | 42 |
| 8.7    | API parameter checking.....                  | 43 |
| 9      | Sequence diagrams.....                       | 45 |
| 9.1    | Initialization.....                          | 45 |
| 9.2    | De-initialization.....                       | 45 |
| 9.3    | Setting the duty cycle.....                  | 46 |
| 9.4    | Setting the period and the duty.....         | 46 |
| 9.5    | Setting the PWM output to idle.....          | 47 |
| 9.6    | Getting the PWM Output state.....            | 47 |
| 9.7    | Using the PWM notifications.....             | 48 |
| 10     | Configuration specification.....             | 49 |
| 10.1   | How to read this chapter.....                | 49 |
| 10.2   | Containers and configuration parameters..... | 49 |
| 10.2.1 | Pwm.....                                     | 49 |
| 10.2.2 | PwmGeneral.....                              | 50 |
| 10.2.3 | PwmPowerStateConfig.....                     | 55 |
| 10.2.4 | PwmChannel.....                              | 57 |
| 10.2.5 | PwmChannelConfigSet.....                     | 62 |
| 10.2.6 | PwmConfigurationOfOptApiServices.....        | 62 |
| 10.3   | Published Information.....                   | 65 |
| 11     | Not applicable requirements.....             | 66 |

# 1 Introduction and functional overview

This specification specifies the functionality, API and the configuration of the AUTOSAR Basic Software module PWM driver.

Each PWM channel is linked to a hardware PWM which belongs to the microcontroller. The type of the PWM signal (for example center Align, left Align, Etc..) is not defined within this specification and is left up to the implementation.

The driver provides functions for initialization and control of the microcontroller internal PWM stage (pulse width modulation). The PWM module generates pulses with variable pulse width. It allows the selection of the duty cycle and the signal period time.

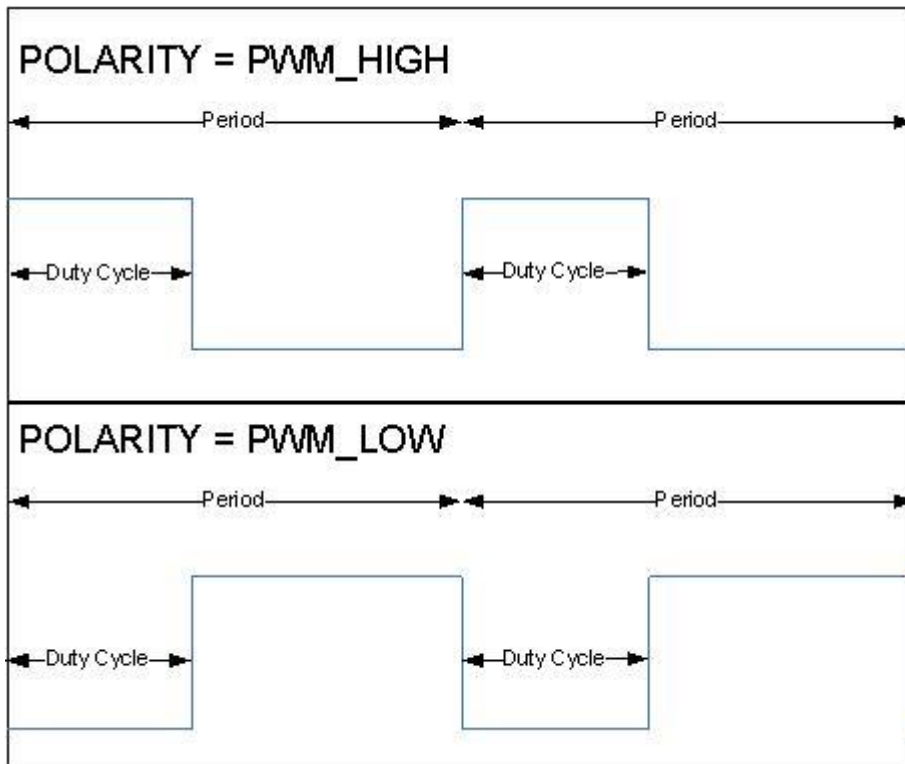

Figure 1: PWM signal description



## 2 Acronyms and abbreviations

Acronyms and abbreviations that have a local scope are not contained in the AUTOSAR glossary. These must appear in a local glossary.

| <b>Acronym:</b>  | <b>Description:</b>   |
|------------------|---|
| PWM Channel      | Numeric identifier linked to a hardware PWM.  |
| PWM Output State | Defines the output state for a PWM signal. It could be: <ul style="list-style-type: none"> <li>▪ High.</li> <li>▪ Low.</li> </ul> |
| PWM Idle State   | The idle state represents the output state of the PWM channel after the call of Pwm_SetOutputToIdle or Pwm_DeInit                 |
| PWM Polarity     | Defines the starting output state of each PWM channel   |
| PWM Duty cycle   | Defines a percentage of the starting level (could be high or low) related to the period.  |
| PWM period       | Defines the period of the PWM signal.   |

| <b>Abbreviation:</b> | <b>Description:</b>        |
|----------------------|----------------------------|
| PWM                  | Pulse Width Modulation.    |
| DEM                  | Diagnostic Event Manager.  |
| DET                  | Default Error Tracer.      |
| MCU                  | Microcontroller Unit.      |
| PLL                  | Phase Locked Loop.         |
| ISR                  | Interrupt Service Routine. |

## 3 Related documentation

### 3.1 Input documents

- [1] Layered Software Architecture  
AUTOSAR\_CP\_EXP\_LayeredSoftwareArchitecture.pdf
- [2] General Requirements on SPAL  
AUTOSAR\_CP\_SRS\_SPALGeneral.pdf
- [3] General Requirements on Basic Software Modules  
AUTOSAR\_CP\_SRS\_BSWGeneral.pdf
- [4] Specification of Default Error Tracer  
AUTOSAR\_CP\_SWS\_DefaultErrorTracer.pdf
- [5] Specification of MCU Driver  
AUTOSAR\_CP\_SWS\_MCUDriver.pdf
- [6] Specification of ECU Configuration,  
AUTOSAR\_CP\_TPS\_ECUConfiguration.pdf
- [7] Basic Software Module Description Template,  
AUTOSAR\_CP\_TPS\_BSWModuleDescriptionTemplate.pdf
- [8] List of Basic Software Modules  
AUTOSAR\_CP\_TR\_BSWModuleList
- [9] General Specification of Basic Software Modules  
AUTOSAR\_CP\_SWS\_BSWGeneral.pdf

### 3.2 Related specification

AUTOSAR provides a General Specification on Basic Software modules [9] (SWS BSW General), which is also valid for PWM Driver.

Thus, the specification SWS BSW General shall be considered as additional and required specification for PWM Driver.

## 4 Constraints and assumptions

### 4.1 Limitations

**[SWS\_Pwm\_00001]** [The Pwm SWS does not cover PWM emulation on general purpose I/O.] (SRS\_Pwm\_12386)

- Power State Control APIs are implementable only if the MCAL driver owns the complete underlying HW peripheral i.e. the HW peripheral is not accessed by other MCAL modules.

### 4.2 Applicability to car domains

No restrictions.

## 5 Dependencies to other modules

The PWM depends on the system clock. Thus, changes of the system clock (e.g. PLL on → PLL off) also affect the clock settings of the PWM hardware.

The PWM Driver depends on the following modules:

- PORT Driver: To set the port pin functionality. **PWM141**
- MCU Driver: To set prescaler, system clock and PLL. **PWM142**
- DET: Default Error Tracer in Development mode. **PWM143**

The document 087\_AUTOSAR\_ECU\_Configuration contains a chapter 4.6 - *Clock Tree Configuration*, which details the mechanism to deliver reference clock signals to peripherals.

### 5.1 File structure

#### 5.1.1 Code file structure

**[SWS\_Pwm\_00065]** [The Pwm SWS shall not define the code file structure.]  
(SRS\_BSW\_00346, SRS\_BSW\_00314)

#### 5.1.2 Header file structure

**[SWS\_Pwm\_50075]** [Pwm.c shall include Pwm.h, Det.h and .] ()

**[SWS\_Pwm\_70075]** [Pwm\_Irq.c shall include Pwm.h.] ()

## 6 Requirements traceability

| Requirement   | Description  | Satisfied by   |
|---------------|--|--|
| SRS_BSW_00101 | The Basic Software Module shall be able to initialize variables and hardware in a separate initialization function                             | SWS_Pwm_00007  |
| SRS_BSW_00171 | Optional functionality of a Basic-SW component that is not required in the ECU shall be configurable at pre-compile-time                       | SWS_Pwm_10080, SWS_Pwm_10082, SWS_Pwm_10083, SWS_Pwm_10084, SWS_Pwm_10085, SWS_Pwm_20080, SWS_Pwm_20082, SWS_Pwm_20083, SWS_Pwm_20084, SWS_Pwm_20085 |
| SRS_BSW_00314 | All internal driver modules shall separate the interrupt frame definition from the service routine   | SWS_Pwm_00065  |
| SRS_BSW_00323 | All AUTOSAR Basic Software Modules shall check passed API parameters for validity  | SWS_Pwm_00045, SWS_Pwm_00047, SWS_Pwm_00117, SWS_Pwm_10051, SWS_Pwm_20051, SWS_Pwm_30051   |
| SRS_BSW_00336 | Basic SW module shall be able to shutdown  | SWS_Pwm_00010  |
| SRS_BSW_00337 | Classification of development errors   | SWS_Pwm_20002, SWS_Pwm_30002, SWS_Pwm_40002, SWS_Pwm_50002   |
| SRS_BSW_00343 | The unit of time for specification and configuration of Basic SW modules shall be preferably in physical time unit                             | SWS_Pwm_00070  |
| SRS_BSW_00346 | All AUTOSAR Basic Software Modules shall provide at least a basic set of module files  | SWS_Pwm_00065  |
| SRS_BSW_00385 | List possible error notifications  | SWS_Pwm_20002, SWS_Pwm_30002, SWS_Pwm_40002, SWS_Pwm_50002   |
| SRS_BSW_00386 | The BSW shall specify the configuration and conditions for detecting an error  | SWS_Pwm_00045, SWS_Pwm_00047, SWS_Pwm_00117, SWS_Pwm_10051, SWS_Pwm_20002, SWS_Pwm_20051, SWS_Pwm_30002, SWS_Pwm_30051, SWS_Pwm_40002, SWS_Pwm_50002 |
| SRS_BSW_00406 | A static status variable denoting if a BSW module is initialized shall be initialized with value 0 before any APIs of the BSW module is called | SWS_Pwm_00117  |
| SRS_Pwm_12293 | The PWM driver shall allow the static configuration of PWM channel properties  | SWS_Pwm_00197  |
| SRS_Pwm_12295 | The PWM driver shall provide a service for setting the duty cycle of a selected channel  | SWS_Pwm_00013  |
| SRS_Pwm_12297 | The PWM driver shall provide a service for setting the period of a selected channel  | SWS_Pwm_00019  |

|                |  |  |
|----------------|--|--|
| SRS_Pwm_12299  | The PWM driver shall allow to enable/disable the PWM edges notification during runtime                                 | SWS_Pwm_00023, SWS_Pwm_00024   |
| SRS_Pwm_12358  | The PWM driver shall be capable to set the output of selected channel to a given state immediately                     | SWS_Pwm_00021  |
| SRS_Pwm_12378  | The PWM driver shall be able to assign notification to each edges of the PWM-signal                                    | SWS_Pwm_00023, SWS_Pwm_00024, SWS_Pwm_00197  |
| SRS_Pwm_12381  | By de-initializing the PWM driver, all PWM-channels shall be stop  | SWS_Pwm_00010  |
| SRS_Pwm_12382  | The PWM Driver shall wait to the end of the signal period to update the duty cycle of a PWM signal                     | SWS_Pwm_00017  |
| SRS_Pwm_12383  | The PWM driver shall provide a 16 bit interface to set the duty cycle  | SWS_Pwm_00058  |
| SRS_Pwm_12385  | The PWM driver shall provide a service to get the state of a PWM channel output  | SWS_Pwm_00022  |
| SRS_Pwm_12386  | The PWM driver shall not cover a PWM emulation on general purpose I/O  | SWS_Pwm_00001  |
| SRS_Pwm_12389  | The PWM driver shall allow only static configuration of the frequency for some PWM channels                            | SWS_Pwm_00041  |
| SRS_Pwm_12459  | The PWM Driver shall provide a scaling scheme for duty cycle   | SWS_Pwm_00059  |
| SRS_SPAL_00157 | All drivers and handlers of the AUTOSAR Basic Software shall implement notification mechanisms of drivers and handlers | SWS_Pwm_00025  |
| SRS_SPAL_12057 | All driver modules shall implement an interface for initialization   | SWS_Pwm_00007, SWS_Pwm_00052, SWS_Pwm_00062, SWS_Pwm_10009, SWS_Pwm_20009, SWS_Pwm_30009 |
| SRS_SPAL_12125 | All driver modules shall only initialize the configured resources  | SWS_Pwm_00062  |
| SRS_SPAL_12129 | The ISRs shall be responsible for resetting the interrupt flags and calling the according notification function        | SWS_Pwm_00026  |
| SRS_SPAL_12163 | All driver modules shall implement an interface for de-initialization  | SWS_Pwm_00010, SWS_Pwm_00011, SWS_Pwm_00012  |

## 7 Functional specification

### 7.1 General behavior

**[SWS\_Pwm\_00088]** [All functions from the PWM module except `Pwm_Init`, `Pwm_DeInit` and `Pwm_GetVersionInfo` shall be re-entrant for different PWM channel numbers.

In order to keep a simple module implementation, no check of SWS\_Pwm\_00088 must be performed by the module. ] ()

**[SWS\_Pwm\_00089]** [The Pwm module's user shall ensure the integrity if several function calls are made during run time in different tasks or ISRs for the same PWM channel.]()

### 7.2 Time Unit Ticks

#### 7.2.1 Background & Rationale

To get times out of register values it is necessary to know the oscillator frequency, prescalers and so on. Since these settings are made in MCU and/or in other modules it is not possible to calculate such times.

Hence the conversions between time and ticks shall be part of an upper layer.

#### 7.2.2 Requirements

**[SWS\_Pwm\_00070]** [All time units used within the API services of the PWM module shall be of the unit ticks. ](SRS\_BSW\_00343)

### 7.3 Support and management of HW low power states

Some PWM HW Module allow to be set in some operation modes which reduce the power consumption, eventually at the cost of a slower reaction time, a lower performance or eventually complete unavailability. Each PWM module could support one or more low power operation modes, considering the Full Power Mode as always present and set per default at startup.

#### 7.3.1 Background

The PWM Driver offers power state control APIs and a background elaboration mechanism to handle asynchronous power state change processes (i.e. power state

changes which are not immediately complete as the they are requested, but need some longer operations).

It is assumed that all constraints deriving from ECU and SW architecture are already satisfied by the upper layers (Application, Mode Management in the service layer, IoHwAbstraction components dealing with peripheral control), thus the scope of control is limited to the PWM HW peripheral.

A check on the operation sequence is executed by the PWM Driver in order to avoid requesting a different power state before the previous request is still being processed or activating a power state when no preparation for the same has been requested.

The PWM module shall support power control capabilities as an optional function. This module neither mandates to use only power control enabled MCUs nor to configure the same. Rather it proposes a way to handle power states if this is supported by the suppliers.

### 7.3.2 Requirements

**[SWS\_Pwm\_00154]** 「The PwmDriver shall support power state changes and its APIs when the corresponding configuration parameter `PwmLowPowerStatesSupport` is set to TRUE.」()

**[SWS\_Pwm\_00155]** 「If the parameter `PwmLowPowerStatesSupport` is enabled then the APIs `Pwm_PreparePowerState`, `Pwm_SetPowerState`, `Pwm_GetCurrentPowerState`, `Pwm_GetTargetPowerState` shall be generated and shall be used to manage and get informations on power state transitions.」()

**[SWS\_Pwm\_00156]** 「The APIs `Pwm_GetTargetPowerState` and `Pwm_GetCurrentPowerState` shall be respectively used to gather information on the requested and the target Pwm power states.」()

**[SWS\_Pwm\_00157]** 「The API `Pwm_PreparePowerState` shall be used to start a power state transition.」()

**[SWS\_Pwm\_00158]** 「After preparation for a power state is achieved by (**[SWS\_Pwm\_00157]**) then the API `Pwm_SetPowerState` shall be used to achieve the requested power state of the Pwm module.

In order to avoid incoherent power state conditions, some APIs (`Pwm_SetPowerState`, `Pwm_PreparePowerState`) have to be called in a given sequence, otherwise an error (if DET tracing is enabled) is stored and the action is interrupted. The Pwm Driver keeps track of the call sequence.」()



**[SWS\_Pwm\_00159]** 「The Pwm Driver shall keep track of the call order of the APIs `Pwm_SetPowerState` and `Pwm_PreparePowerState`. In case the first one is called before the second one is called, a DET entry shall be stored and the action shall not be executed.」()

**[SWS\_Pwm\_00160]** 「The Pwm Module shall keep track of the current and of the target powerstate if the parameter `PwmLowPowerStatesSupport` is set to `TRUE`」()

**[SWS\_Pwm\_00161]** 「After the Initialization the power state of the module shall be always `FULL POWER` if the `PwmLowPowerStatesSupport` is set to `TRUE`.」()

**[SWS\_Pwm\_00162]** 「The Pwm Driver shall support synchronous and asynchronous power state transitions, depending on the value of the configuration parameter `PwmPowerStateAsynchTransitionMode`.」()

**[SWS\_Pwm\_00163]** 「In case the configuration parameter `PwmPowerStateAsynchTransitionMode` is set to `FALSE`, the preparation process and the setting process shall be considered concluded as soon as the respective APIs return.」()

**[SWS\_Pwm\_00164]** 「In case the configuration parameter `PwmPowerStateAsynchTransitionMode` is set to `TRUE`, the preparation process shall continue in background after the relative API returns and its completion shall be notified by means of the configured callback.」()

## 7.4 Duty Cycle Resolution and scaling

**[SWS\_Pwm\_00058]** 「The width of the duty cycle parameter is 16 Bits.」  
(SRS\_Pwm\_12383)

**[SWS\_Pwm\_00059]** 「The Pwm module shall comply with the following scaling scheme for the duty cycle:

- `0x0000` means 0%.
- `0x8000` means 100%. `0x8000` gives the highest resolution while allowing 100% duty cycle to be represented with a 16 bit value.

As an implementation guide, the following source code example is given:

```
AbsoluteDutyCycle =
((uint32)AbsolutePeriodTime * RelativeDutyCycle) >> 15;
」(SRS_Pwm_12459)
```

## 7.5 Version check

For details refer to the chapter 5.1.8 “Version Check” in *SWS\_BSWGeneral*.

## 7.6 Error classification

### 7.6.1 Development Errors

#### [SWS\_Pwm\_00201]

| <i>Type of error</i>  | <i>Related error code</i>       | <i>Error value</i> |
|---|---------------------------------|--------------------|
| API Pwm_Init service called with wrong parameter  | PWM_E_INIT_FAILED               | 0x10               |
| API service used without module initialization  | PWM_E_UNINIT                    | 0x11               |
| API service used with an invalid channel Identifier   | PWM_E_PARAM_CHANNEL             | 0x12               |
| Usage of unauthorized PWM service on PWM channel configured a fixed period                        | PWM_E_PERIOD_UNCHANGEABLE       | 0x13               |
| API Pwm_Init service called while the PWM driver has already been initialised                     | PWM_E_ALREADY_INITIALIZED       | 0x14               |
| API Pwm_GetVersionInfo is called with a NULL parameter.   | PWM_E_PARAM_POINTER             | 0x15               |
| The requested power state is not supported by the PWM module.                                     | PWM_E_POWER_STATE_NOT_SUPPORTED | 0x17               |
| The requested power state is not reachable from the current one                                   | PWM_E_TRANSITION_NOT_POSSIBLE   | 0x18               |
| API Pwm_SetPowerState has been called without having called the API Pwm_PreparePowerState before. | PWM_E_PERIPHERAL_NOT_PREPARED   | 0x19               |

()

**[SWS\_Pwm\_20002]** [The PWM Driver module shall report the development error "PWM\_E\_UNINIT (0x11)", when API service is used without module initialization. ]  
(SRS\_BSW\_00337, SRS\_BSW\_00385, SRS\_BSW\_00386)

**[SWS\_Pwm\_30002]** [The PWM Driver module shall report the development error "PWM\_E\_PARAM\_CHANNEL (0x12)", when API service is used with an invalid channel Identifier. ] (SRS\_BSW\_00337, SRS\_BSW\_00385, SRS\_BSW\_00386)

**[SWS\_Pwm\_40002]** [The PWM Driver module shall report the development error "PWM\_E\_PERIOD\_UNCHANGEABLE (0x13)", on usage of unauthorized PWM

service on PWM channel configured a fixed period. ] (SRS\_BSW\_00337, SRS\_BSW\_00385, SRS\_BSW\_00386)

**[SWS\_Pwm\_50002]** [The PWM Driver module shall report the development error "PWM\_E\_ALREADY\_INITIALIZED(0x14)", when API Pwm\_Init service is called while the PWM driver has already been initialized. ] (SRS\_BSW\_00337, SRS\_BSW\_00385, SRS\_BSW\_00386)

**[SWS\_Pwm\_00174]**

[The API shall report the development error **PWM\_E\_POWER\_STATE\_NOT\_SUPPORTED** in case this API is called with an unsupported power state or the peripheral does not support low power states at all. ]  
( )

**[SWS\_Pwm\_00175]**

[The API shall report the development error **PWM\_E\_TRANSITION\_NOT\_POSSIBLE** in case the requested power state cannot be directly reached from the current power state. ]( )

**[SWS\_Pwm\_00176]**

[The API shall report the development error **PWM\_E\_PERIPHERAL\_NOT\_PREPARED** in case the HW unit has not been previously prepared for the target power state by use of the API Pwm\_PreparePowerState(). ]( )

To get more details concerning error detection, refer to chapter [API parameter checking](#).

**7.6.2 Runtime Errors**

**[SWS\_Pwm\_00202]**[

| <i>Type of error</i>  | <i>Related error code</i> | <i>Error value</i> |
|---|---------------------------|--------------------|
| API Pwm_SetPowerState is called while the PWM module is still in use. | PWM_E_NOT_DISENGAGED      | 0x16               |

] ( )

**[SWS\_Pwm\_00200]**

[The API shall report the runtime error **PWM\_E\_NOT\_DISENGAGED** in case this API is called when one or more HW channels (where applicable) are in a state

different than IDLE (or similar non-operational states) and/or there are still notification registered for the HW module channels. ]()

### **7.6.3 Transient Faults**

There are no transient faults.

### **7.6.4 Production Errors**

There are no production errors.

### **7.6.5 Extended Production Errors**

There are no extended production errors.

## 8 API specification

### 8.1 Imported types

This chapter lists all types included from other modules.

#### [SWS\_Pwm\_00094]

| <i>Module</i> | <i>Header File</i> | <i>Imported Type</i> |
|---------------|--------------------|----------------------|
| Std           | Std_Types.h        | Std_ReturnType       |
|               | Std_Types.h        | Std_VersionInfoType  |

]()

### 8.2 Type definitions

#### 8.2.1 Pwm\_ChannelType

##### [SWS\_Pwm\_00106]

|                      |                                      |        |   |
|----------------------|--------------------------------------|--------|---|
| <b>Name</b>          | Pwm_ChannelType                      |        |   |
| <b>Kind</b>          | Type                                 |        |   |
| <b>Derived from</b>  | uint                                 |        |   |
| <b>Range</b>         | 8..32 bit                            | -<br>- | This is implementation specific but not all values may be valid within the type. This type shall be chosen in order to have the most efficient implementation on a specific microcontroller platform. |
| <b>Description</b>   | Numeric identifier of a PWM channel. |        |   |
| <b>Available via</b> | Pwm.h                                |        |   |

]()

#### 8.2.2 Pwm\_PeriodType

##### [SWS\_Pwm\_00107]

|                      |  |        |   |
|----------------------|--|--------|---|
| <b>Name</b>          | Pwm_PeriodType                             |        |   |
| <b>Kind</b>          | Type                                       |        |   |
| <b>Derived from</b>  | uint                                       |        |   |
| <b>Range</b>         | 8..32 bit                                  | -<br>- | Implementation specific. This type shall be chosen in order to have the most efficient implementation on a specific microcontroller platform. |
| <b>Description</b>   | Definition of the period of a PWM channel. |        |   |
| <b>Available via</b> | Pwm.h                                      |        |   |

]()

### 8.2.3 Pwm\_OutputStateType

[SWS\_Pwm\_00108]

|                      |                                |      |                                   |
|----------------------|--------------------------------|------|-----------------------------------|
| <b>Name</b>          | Pwm_OutputStateType            |      |                                   |
| <b>Kind</b>          | Enumeration                    |      |                                   |
| <b>Range</b>         | PWM_HIGH                       | 0x00 | The PWM channel is in high state. |
|                      | PWM_LOW                        | 0x01 | The PWM channel is in low state.  |
| <b>Description</b>   | Output state of a PWM channel. |      |                                   |
| <b>Available via</b> | Pwm.h                          |      |                                   |

]()

### 8.2.4 Pwm\_EdgeNotificationType

[SWS\_Pwm\_00109]

|                      |   |      |   |
|----------------------|---|------|---|
| <b>Name</b>          | Pwm_EdgeNotificationType                                      |      |   |
| <b>Kind</b>          | Enumeration   |      |   |
| <b>Range</b>         | PWM_RISING_EDGE   | 0x00 | Notification will be called when a rising edge occurs on the PWM output signal.                       |
|                      | PWM_FALLING_EDGE  | 0x01 | Notification will be called when a falling edge occurs on the PWM output signal.                      |
|                      | PWM_BOTH_EDGES  | 0x02 | Notification will be called when either a rising edge or falling edge occur on the PWM output signal. |
| <b>Description</b>   | Definition of the type of edge notification of a PWM channel. |      |   |
| <b>Available via</b> | Pwm.h   |      |   |

]()

### 8.2.5 Pwm\_ChannelClassType

[SWS\_Pwm\_00110]

|              |                      |      |  |
|--------------|----------------------|------|--|
| <b>Name</b>  | Pwm_ChannelClassType |      |  |
| <b>Kind</b>  | Enumeration          |      |  |
| <b>Range</b> | PWM_VARIABLE_PERIOD  | 0x00 | The PWM channel has a variable period. The duty cycle and the period can be changed. |
|              | PWM_FIXED_PERIOD     | 0x01 | The PWM channel has a fixed period. Only the duty cycle can be changed.              |

|                      |                                    |      |  |
|----------------------|------------------------------------|------|--|
|                      | PWM_FIXED_PERIOD_SHIFTED           | 0x02 | The PWM channel has a fixed shifted period. Impossible to change it ( only if supported by hardware) |
| <b>Description</b>   | Defines the class of a PWM channel |      |  |
| <b>Available via</b> | Pwm.h                              |      |  |

]()

### 8.2.6 Pwm\_ConfigType

[SWS\_Pwm\_00111]

|                      |   |  |  |
|----------------------|---|--|--|
| <b>Name</b>          | Pwm_ConfigType  |  |  |
| <b>Kind</b>          | Structure   |  |  |
| <b>Elements</b>      | Hardware dependent structure.   |  |  |
|                      | <b>Type</b>   | --   |  |
|                      | <b>Comment</b>  | The contents of the initialization data structure are hardware specific. |  |
| <b>Description</b>   | This is the type of data structure containing the initialization data for the PWM driver. |  |  |
| <b>Available via</b> | Pwm.h   |  |  |

]()

### 8.2.7 Pwm\_PowerStateRequestResultType

[SWS\_Pwm\_00165]

|                    |  |      |   |
|--------------------|--|------|---|
| <b>Name</b>        | Pwm_PowerStateRequestResultType                            |      |   |
| <b>Kind</b>        | Enumeration  |      |   |
| <b>Range</b>       | PWM_SERVICE_ACCEPTED                                       | 0x00 | Power state change executed.  |
|                    | PWM_NOT_INIT   | 0x01 | PWM Module not initialized.   |
|                    | PWM_SEQUENCE_ERROR   | 0x02 | Wrong API call sequence.  |
|                    | PWM_HW_FAILURE   | 0x03 | The HW module has a failure which prevents it to enter the required power state.  |
|                    | PWM_POWER_STATE_NOT_SUPP                                   | 0x04 | PWM Module does not support the requested power state.  |
|                    | PWM_TRANS_NOT_POSSIBLE                                     | 0x05 | PWM Module cannot transition directly from the current power state to the requested power state or the HW peripheral is still busy. |
| <b>Description</b> | Result of the requests related to power state transitions. |      |   |

|                      |       |
|----------------------|-------|
| <b>Available via</b> | Pwm.h |
|----------------------|-------|

]()

### 8.2.8 Pwm\_PowerStateType

[SWS\_Pwm\_00197][

|                      |  |      |   |
|----------------------|--|------|---|
| <b>Name</b>          | Pwm_PowerStateType   |      |   |
| <b>Kind</b>          | Enumeration  |      |   |
| <b>Range</b>         | 1..255   | --   | power modes with decreasing power consumptions. |
|                      | PWM_FULL_POWER   | 0x00 | Full Power                                      |
| <b>Description</b>   | Power state currently active or set as target power state. |      |   |
| <b>Available via</b> | Pwm.h  |      |   |

](SRS\_Pwm\_12293, SRS\_Pwm\_12378)

Mandatory parameters:

- Assigned HW channel
- Default value for period
- Default value for duty cycle
- Polarity ( high or low )
- Idle state high or low
- Channel class:
  - Fixed period
  - Fixed period, shifted (if supported by hardware)
  - Variable period

Optional parameters (if supported by hardware):

- Channel phase shift
- Reference channel for phase shift
- Microcontroller specific channel properties

## 8.3 Function definitions

### 8.3.1 Pwm\_Init

[SWS\_Pwm\_00095][

|                         |  |
|-------------------------|--|
| <b>Service Name</b>     | Pwm_Init   |
| <b>Syntax</b>           | <pre>void Pwm_Init (     const Pwm_ConfigType* ConfigPtr )</pre> |
| <b>Service ID [hex]</b> | 0x00   |
| <b>Sync/Async</b>       | Synchronous  |



|                           |                                 |                              |
|---------------------------|---------------------------------|------------------------------|
| <b>Reentrancy</b>         | Non Reentrant                   |                              |
| <b>Parameters (in)</b>    | ConfigPtr                       | Pointer to configuration set |
| <b>Parameters (inout)</b> | None                            |                              |
| <b>Parameters (out)</b>   | None                            |                              |
| <b>Return value</b>       | None                            |                              |
| <b>Description</b>        | Service for PWM initialization. |                              |
| <b>Available via</b>      | Pwm.h                           |                              |

]()

**[SWS\_Pwm\_00007]** 「The function Pwm\_Init shall initialize all internal variables and the used PWM structure of the microcontroller according to the parameters specified in ConfigPtr.」( SRS\_BSW\_00101, SRS\_SPAL\_12057)

**[SWS\_Pwm\_00062]** 「The function Pwm\_Init shall only initialize the configured resources and shall not touch resources that are not configured in the configuration file. 」(SRS\_SPAL\_12057, SRS\_SPAL\_12125)

**[SWS\_Pwm\_10009]** 「The function Pwm\_Init shall start all PWM channels with the configured default values. 」(SRS\_SPAL\_12057)

If the duty cycle parameter equals:

- **[SWS\_Pwm\_20009]** 「0% or 100% : Then the PWM output signal shall be in the state according to the configured polarity parameter」(SRS\_SPAL\_12057)
- **[SWS\_Pwm\_30009]** 「>0% and <100%: Then the PWM output signal shall be modulated according to parameters period, duty cycle and configured polarity. 」(SRS\_SPAL\_12057)

**[SWS\_Pwm\_00052]** 「The function Pwm\_Init shall disable all notifications. 」(SRS\_SPAL\_12057)

The reason is that the users of these notifications may not be ready. They can call Pwm\_EnableNotification to start notifications.

**[SWS\_Pwm\_00093]** 「The users of the Pwm module shall not call the function Pwm\_Init during a running operation. 」()

**[SWS\_Pwm\_00116]** 「The Pwm module's environment shall not call any function of the Pwm module before having called Pwm\_Init. .」()

**[SWS\_Pwm\_00118]** 「If development error detection is enabled, calling the routine Pwm\_Init while the PWM driver and hardware are already initialized will cause a

development error PWM\_E\_ALREADY\_INITIALIZED. The desired functionality shall be left without any action. ] ()

**[SWS\_Pwm\_00121]** [A re-initialization of the Pwm driver by executing the Pwm\_Init() function requires a de-initialization before by executing a Pwm\_DeInit(). ] ()

Regarding error detection, the requirement SWS\_Pwm\_10051 and SWS\_Pwm\_20051 are applicable to the function Pwm\_Init.

### 8.3.2 Pwm\_DeInit

**[SWS\_Pwm\_00096]**[

|                           |                                    |
|---------------------------|------------------------------------|
| <b>Service Name</b>       | Pwm_DeInit                         |
| <b>Syntax</b>             | void Pwm_DeInit (<br>void<br>)     |
| <b>Service ID [hex]</b>   | 0x01                               |
| <b>Sync/Async</b>         | Synchronous                        |
| <b>Reentrancy</b>         | Non Reentrant                      |
| <b>Parameters (in)</b>    | None                               |
| <b>Parameters (inout)</b> | None                               |
| <b>Parameters (out)</b>   | None                               |
| <b>Return value</b>       | None                               |
| <b>Description</b>        | Service for PWM De-Initialization. |
| <b>Available via</b>      | Pwm.h                              |

]()

**[SWS\_Pwm\_00010]** [The function Pwm\_DeInit shall de-initialize the PWM module. ] (SRS\_BSW\_00336, SRS\_SPAL\_12163, SRS\_Pwm\_12381)

**[SWS\_Pwm\_00011]** [The function Pwm\_DeInit shall set the state of the PWM output signals to the idle state. ] (SRS\_SPAL\_12163)

**[SWS\_Pwm\_00012]** [The function Pwm\_DeInit shall disable PWM interrupts and PWM signal edge notifications. ] (SRS\_SPAL\_12163)

**[SWS\_Pwm\_10080]** [The function Pwm\_DeInit shall be pre compile time configurable On/Off by the configuration parameter: PwmDeInitApi. ] (SRS\_BSW\_00171)

**[SWS\_Pwm\_20080]** [The function Pwm\_DelInit shall be configurable On/Off by the configuration parameter PwmDelInitApi {PWM\_DE\_INIT\_API}.

Regarding error detection, the requirements [SWS\\_Pwm\\_00117](#), SWS\_Pwm\_10051, and SWS\_Pwm\_20051 are applicable to the function Pwm\_DelInit. ]  
(SRS\_BSW\_00171)

### 8.3.3 Pwm\_SetDutyCycle

**[SWS\_Pwm\_91000]**[

|                           |  |                               |
|---------------------------|--|-------------------------------|
| <b>Service Name</b>       | Pwm_SetDutyCycle   |                               |
| <b>Syntax</b>             | <pre>void Pwm_SetDutyCycle (     Pwm_ChannelType ChannelNumber,     uint16 DutyCycle )</pre> |                               |
| <b>Service ID [hex]</b>   | 0x02   |                               |
| <b>Sync/Async</b>         | Asynchronous   |                               |
| <b>Reentrancy</b>         | Reentrant for different channel numbers  |                               |
| <b>Parameters (in)</b>    | ChannelNumber  | Numeric identifier of the PWM |
|                           | DutyCycle  | Min=0x0000 Max=0x8000         |
| <b>Parameters (inout)</b> | None   |                               |
| <b>Parameters (out)</b>   | None   |                               |
| <b>Return value</b>       | None   |                               |
| <b>Description</b>        | Service sets the duty cycle of the PWM channel.  |                               |
| <b>Available via</b>      | Pwm.h  |                               |

]()

**[SWS\_Pwm\_00013]** [The function Pwm\_SetDutyCycle shall set the duty cycle of the PWM channel. ] (SRS\_Pwm\_12295)

**[SWS\_Pwm\_00014]** [When the requested duty cycle is either 0% or 100%, the function Pwm\_SetDutyCycle shall set the PWM output state to either PWM\_HIGH or PWM\_LOW, with regard to both the configured polarity parameter and the requested duty cycle. Thus for 0% requested Duty Cycle the output will be the inverse of the configured polarity parameter, and for 100% Duty Cycle the output will be equal to the configured polarity parameter. ] ()

**[SWS\_Pwm\_00016]** [The function Pwm\_SetDutyCycle shall modulate the PWM output signal according to parameters period, duty cycle and configured polarity, when the duty cycle > 0 % and < 100%.] ()

**[SWS\_Pwm\_00017]** [The function Pwm\_SetDutyCycle shall update the duty cycle always at the end of the period if supported by the implementation and configured with PwmDutyCycleUpdatedEndperiod. ] (SRS\_Pwm\_12382)

Regarding format definition of duty cycle parameter, the requirement [SWS\\_Pwm\\_00058](#) is applicable to the function Pwm\_SetDutyCycle.

Regarding scaling definition of duty cycle parameter, the requirement [SWS\\_Pwm\\_00059](#) is applicable to the function Pwm\_SetDutyCycle.

**[SWS\_Pwm\_00018]** [The driver shall forbid the spike on the PWM output signal. ] ()

Regarding error detection, the requirements [SWS\\_Pwm\\_00117](#), [SWS\\_Pwm\\_00047](#), SWS\_Pwm\_10051 and SWS\_Pwm\_20051 are applicable to the function Pwm\_SetDutyCycle.

**[SWS\_Pwm\_10082]** [The function Pwm\_SetDutyCycle shall be pre compile time configurable On/Off by the configuration parameter: PwmSetDutyCycle. .]

(SRS\_BSW\_00171)

**[SWS\_Pwm\_20082]** [The function Pwm\_SetDutyCycle shall be configurable On/Off by the configuration parameter: PwmSetDutyCycle

{PWM\_SET\_DUTY\_CYCLE\_API}.] (SRS\_BSW\_00171)

### 8.3.4 Pwm\_SetPeriodAndDuty

**[SWS\_Pwm\_91001]**

|                           |   |                               |
|---------------------------|---|-------------------------------|
| <b>Service Name</b>       | Pwm_SetPeriodAndDuty  |                               |
| <b>Syntax</b>             | <pre>void Pwm_SetPeriodAndDuty (     Pwm_ChannelType ChannelNumber,     Pwm_PeriodType Period,     uint16 DutyCycle )</pre> |                               |
| <b>Service ID [hex]</b>   | 0x03  |                               |
| <b>Sync/Async</b>         | Asynchronous  |                               |
| <b>Reentrancy</b>         | Reentrant for different channel numbers   |                               |
| <b>Parameters (in)</b>    | ChannelNumber   | Numeric identifier of the PWM |
|                           | Period  | Period of the PWM signal      |
|                           | DutyCycle   | Min=0x0000 Max=0x8000         |
| <b>Parameters (inout)</b> | None  |                               |

|                         |   |
|-------------------------|---|
| <b>Parameters (out)</b> | None  |
| <b>Return value</b>     | None  |
| <b>Description</b>      | Service sets the period and the duty cycle of a PWM channel |
| <b>Available via</b>    | Pwm.h   |

]()

**[SWS\_Pwm\_00019]** [The function Pwm\_SetPeriodAndDuty shall set the period and the duty cycle of a PWM channel. ] (SRS\_Pwm\_12297)

**[SWS\_Pwm\_00076]** [The function Pwm\_SetPeriodAndDuty shall update the period always at the end of the current period if supported by the implementation and configured with PwmPeriodUpdatedEndperiod. ] ()

**[SWS\_Pwm\_00020]** [When updating the PWM period and duty, the driver shall repress any spikes on the PWM output signal. ] ()

The PWM duty cycle parameter is necessary to maintain the consistency between frequency and duty cycle. Refer to [SWS\\_Pwm\\_00058](#) and [SWS\\_Pwm\\_00059](#) to know the scaling and format definition of duty cycle parameter

Regarding error detection, the requirements [SWS\\_Pwm\\_00117](#), [SWS\\_Pwm\\_00045](#), [SWS\\_Pwm\\_00047](#), SWS\_Pwm\_10051 and SWS\_Pwm\_20051 are applicable to the function Pwm\_SetPeriodAndDuty.

**[SWS\_Pwm\_00041]** [The function Pwm\_SetPeriodAndDuty shall allow changing the period only for the PWM channel declared as variable period type. ]

(SRS\_Pwm\_12389)

**[SWS\_Pwm\_10083]** [The function Pwm\_SetPeriodAndDuty shall be pre compile time configurable On/Off by the configuration parameter: PwmSetPeriodAndDuty. ]

(SRS\_BSW\_00171)

**[SWS\_Pwm\_20083]** [The function Pwm\_SetPeriodAndDuty shall be configurable On/Off by the configuration parameter: PwmSetPeriodAndDuty

{PWM\_SET\_PERIOD\_AND\_DUTY\_API}.] (SRS\_BSW\_00171)

**[SWS\_Pwm\_00150]** [If the period is set to zero the setting of the duty-cycle is not relevant. In this case the output shall be zero (zero percent duty-cycle). ] ()

### 8.3.5 Pwm\_SetOutputToldle

**[SWS\_Pwm\_91002]**[

|                     |                     |
|---------------------|---------------------|
| <b>Service Name</b> | Pwm_SetOutputToldle |
|---------------------|---------------------|

|                           |  |                               |
|---------------------------|--|-------------------------------|
| <b>Syntax</b>             | void Pwm_SetOutputToIdle (<br>Pwm_ChannelType ChannelNumber<br>) |                               |
| <b>Service ID [hex]</b>   | 0x04   |                               |
| <b>Sync/Async</b>         | Asynchronous   |                               |
| <b>Reentrancy</b>         | Reentrant for different channel numbers                          |                               |
| <b>Parameters (in)</b>    | ChannelNumber  | Numeric identifier of the PWM |
| <b>Parameters (inout)</b> | None   |                               |
| <b>Parameters (out)</b>   | None   |                               |
| <b>Return value</b>       | None   |                               |
| <b>Description</b>        | Service sets the PWM output to the configured Idle state.        |                               |
| <b>Available via</b>      | Pwm.h  |                               |

]()

**[SWS\_Pwm\_00021]** [The function Pwm\_SetOutputToIdle shall set immediately the PWM output to the configured Idle state. ] (SRS\_Pwm\_12358)

Regarding error detection, the requirements [SWS\\_Pwm\\_00117](#), [SWS\\_Pwm\\_00047](#), SWS\_Pwm\_10051 and SWS\_Pwm\_20051 are applicable to the function Pwm\_SetOutputToIdle.

**[SWS\_Pwm\_10084]** [The function Pwm\_SetOutputToIdle shall be pre compile time configurable On/Off by the configuration parameter: PwmSetOutputToIdle. ] (SRS\_BSW\_00171)

**[SWS\_Pwm\_20084]** [The function Pwm\_SetOutputToIdle shall be configurable On/Off by the configuration parameter: PwmSetOutputToIdle {PWM\_SET\_OUTPUT\_TO\_IDLE\_API}.] (SRS\_BSW\_00171)

**[SWS\_Pwm\_10086]** [After the call of the function Pwm\_SetOutputToIdle, variable period type channels shall be reactivated using the Api Pwm\_SetPeriodAndDuty( ) to activate the PWM channel with the new passed period. ] ()

**[SWS\_Pwm\_20086]** [After the call of the function Pwm\_SetOutputToIdle, channels shall be reactivated using the Api Pwm\_SetDutyCycle( ) to activate the PWM channel with the old period.]()

**[SWS\_Pwm\_00119]** [After the call of the function Pwm\_SetOutputToIdle, fixed period type channels shall be reactivated using only the API Pwm\_SetDutyCycle() to activate the PWM channel with the old period. ]()

### 8.3.6 Pwm\_GetOutputState

[SWS\_Pwm\_00100]

|                           |  |  |
|---------------------------|--|--|
| <b>Service Name</b>       | Pwm_GetOutputState   |  |
| <b>Syntax</b>             | Pwm_OutputStateType Pwm_GetOutputState (<br>Pwm_ChannelType ChannelNumber<br>) |  |
| <b>Service ID [hex]</b>   | 0x05   |  |
| <b>Sync/Async</b>         | Synchronous  |  |
| <b>Reentrancy</b>         | Reentrant for different channel numbers  |  |
| <b>Parameters (in)</b>    | ChannelNumber  | Numeric identifier of the PWM  |
| <b>Parameters (inout)</b> | None   |  |
| <b>Parameters (out)</b>   | None   |  |
| <b>Return value</b>       | Pwm_OutputStateType  | PWM_HIGH The PWM output state is high<br>PWM_LOW The PWM output state is low |
| <b>Description</b>        | Service to read the internal state of the PWM output signal.                   |  |
| <b>Available via</b>      | Pwm.h  |  |

]()

[SWS\_Pwm\_00022] [The function Pwm\_GetOutputState shall read the internal state of the PWM output signal and return it as defined in the diagram below

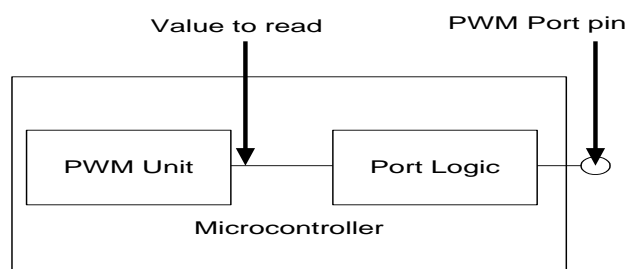

Regarding error detection, the requirements [SWS\\_Pwm\\_00117](#), [SWS\\_Pwm\\_00047](#), [SWS\\_Pwm\\_10051](#) and [SWS\\_Pwm\\_20051](#) are applicable to the function

Pwm\_GetOutputState. ] (SRS\_Pwm\_12385)

[SWS\_Pwm\_10085] [The function Pwm\_GetOutputState shall be pre compile time configurable On/Off using the configuration parameter: PwmGetOutputState. ]

(SRS\_BSW\_00171)

**[SWS\_Pwm\_20085]** [The function Pwm\_GetOutputState shall be configurable On/Off by the configuration parameter: PwmGetOutputState {PWM\_GET\_OUTPUT\_STATE\_API}.

Due to real time constraint and setting of the PWM channel (project dependant), the output state can be modified just after the call of the service Pwm\_GetOutputState. ] (SRS\_BSW\_00171)

**[SWS\_Pwm\_30051]** [If Pwm\_GetOutputState is called before module initialization, or with an invalid channel, it shall return PWM\_LOW.] (SRS\_BSW\_00323, SRS\_BSW\_00386)

### 8.3.7 Pwm\_DisableNotification

**[SWS\_Pwm\_91003]**[

|                           |   |                               |
|---------------------------|---|-------------------------------|
| <b>Service Name</b>       | Pwm_DisableNotification   |                               |
| <b>Syntax</b>             | <pre>void Pwm_DisableNotification (     Pwm_ChannelType ChannelNumber )</pre> |                               |
| <b>Service ID [hex]</b>   | 0x06  |                               |
| <b>Sync/Async</b>         | Asynchronous  |                               |
| <b>Reentrancy</b>         | Reentrant for different channel numbers                                       |                               |
| <b>Parameters (in)</b>    | ChannelNumber   | Numeric identifier of the PWM |
| <b>Parameters (inout)</b> | None  |                               |
| <b>Parameters (out)</b>   | None  |                               |
| <b>Return value</b>       | None  |                               |
| <b>Description</b>        | Service to disable the PWM signal edge notification.                          |                               |
| <b>Available via</b>      | Pwm.h   |                               |

]()

**[SWS\_Pwm\_00023]** [The function Pwm\_DisableNotification shall disable the PWM signal edge notification. ] (SRS\_Pwm\_12378, SRS\_Pwm\_12299)

**[SWS\_Pwm\_10112]** [The function Pwm\_DisableNotification shall be pre compile time configurable On/Off using the configuration parameter: PwmNotificationSupported. ] ()

**[SWS\_Pwm\_20112]** [The function Pwm\_DisableNotification shall be configurable On/Off by the configuration parameter: PwmNotificationSupported {PWM\_NOTIFICATION\_SUPPORTED}.



Regarding error detection, the requirements [SWS\\_Pwm\\_00117](#), [SWS\\_Pwm\\_00047](#), SWS\_Pwm\_10051 and SWS\_Pwm\_20051 are applicable to the function

Pwm\_DisableNotification. ] ()

### 8.3.8 Pwm\_EnableNotification

#### [SWS\_Pwm\_91004]

|                           |   |  |
|---------------------------|---|--|
| <b>Service Name</b>       | Pwm_EnableNotification  |  |
| <b>Syntax</b>             | <pre>void Pwm_EnableNotification (     Pwm_ChannelType ChannelNumber,     Pwm_EdgeNotificationType Notification )</pre> |  |
| <b>Service ID [hex]</b>   | 0x07  |  |
| <b>Sync/Async</b>         | Asynchronous  |  |
| <b>Reentrancy</b>         | Reentrant for different channel numbers   |  |
| <b>Parameters (in)</b>    | Channel Number  | Numeric identifier of the PWM  |
|                           | Notification  | Type of notification PWM_RISING_EDGE or PWM_FALLING_EDGE or PWM_BOTH_EDGES |
| <b>Parameters (inout)</b> | None  |  |
| <b>Parameters (out)</b>   | None  |  |
| <b>Return value</b>       | None  |  |
| <b>Description</b>        | Service to enable the PWM signal edge notification according to notification parameter.                                 |  |
| <b>Available via</b>      | Pwm.h   |  |

]()

**[SWS\_Pwm\_00024]** [The function Pwm\_EnableNotification shall enable the PWM signal edge notification according to notification parameter. ] (SRS\_Pwm\_12378, SRS\_Pwm\_12299)

**[SWS\_Pwm\_00081]** [The function Pwm\_EnableNotification shall cancel pending interrupts. ] ()

**[SWS\_Pwm\_10113]** [The function Pwm\_EnableNotification shall be pre compile time configurable On/Off using the configuration parameter: PwmNotificationSupported. ] ()

**[SWS\_Pwm\_20113]** [The function Pwm\_EnableNotification shall be configurable On/Off by the configuration parameter: PwmNotificationSupported {PWM\_NOTIFICATION\_SUPPORTED}].

Regarding error detection, the requirements [SWS\\_Pwm\\_00117](#), [SWS\\_Pwm\\_00047](#), SWS\_Pwm\_10051 and SWS\_Pwm\_20051 are applicable to the function Pwm\_EnableNotification. ] ()

### 8.3.9 Pwm\_SetPowerState

**[SWS\_Pwm\_00166]**[

|                           |  |   |
|---------------------------|--|---|
| <b>Service Name</b>       | Pwm_SetPowerState  |   |
| <b>Syntax</b>             | Std_ReturnType Pwm_SetPowerState (<br>Pwm_PowerStateRequestResultType* Result<br>)   |   |
| <b>Service ID [hex]</b>   | 0x09   |   |
| <b>Sync/Async</b>         | Synchronous  |   |
| <b>Reentrancy</b>         | Non Reentrant  |   |
| <b>Parameters (in)</b>    | None   |   |
| <b>Parameters (inout)</b> | None   |   |
| <b>Parameters (out)</b>   | Result   | If the API returns E_OK: PWM_SERVICE_ACCEPTED:Power state change executed.<br>If the API returns E_NOT_OK: PWM_NOT_INIT: PWM Module not initialized. PWM_SEQUENCE_ERROR: wrong API call sequence.<br>PWM_HW_FAILURE: the HW module has a failure which prevents it to enter the required power state. |
| <b>Return value</b>       | Std - Return-Type  | E_OK: Power Mode changed<br>E_NOT_OK: request rejected  |
| <b>Description</b>        | This API configures the Pwm module so that it enters the already prepared power state, chosen between a predefined set of configured ones. |   |
| <b>Available via</b>      | Pwm.h  |   |

]()

**[SWS\_Pwm\_00167]**

[The API configures the HW in order to enter the given Power State. All preliminary actions to enable this transition (e.g. setting all channels in IDLE status, de-registering of all notifications and so on) must already have been taken by the responsible SWCs (e.g. IoHwAbs).

The API shall not execute preliminary, implicit power state changes (i.e. if a requested power state is not reachable starting from the current one, no intermediate power state change shall be executed and the request shall be rejected)。」()

**[SWS\_Pwm\_00168]**

「In case the target power state is the same as the current one, no action is executed and the API returns immediately with an E\_OK result.」()

**[SWS\_Pwm\_00169]**

「In case the normal Power State is requested, the API shall refer to the necessary parameters contained in the same containers used by Pwm\_Init.

No separate container or hard coded data shall be used for the normal (i.e. full) power mode, in order to avoid misalignments between initialization parameters used during the init phase and during a power state change.」()

**[SWS\_Pwm\_00170]**

「For the other power states, only power state transition specific reconfigurations shall be executed in the context of this API (i.e. the API cannot be used to apply a completely new configuration to the Pwm module). Any other re-configuration not strictly related to the power state transition shall not take place.」()

**[SWS\_Pwm\_00171]**

「The API shall refer to the configuration container related to the required Power State in order to derive some specific features of the state (e.g support of Power States).」()

In case development error reporting is activated:

**[SWS\_Pwm\_00172]**

「The API shall report the development error **PWM\_E\_UNINIT** in case this API is called before having initialized the HW unit.」()

**[SWS\_Pwm\_00173]**

「The API shall report the runtime error **PWM\_E\_NOT\_DISENGAGED** in case this API is called when one or more HW channels (where applicable) are in a state different than IDLE (or similar non-operational states) and/or there are still notification registered for the HW module channels.」()

**[SWS\_Pwm\_00194]**

「The API shall report the development error **PWM\_E\_POWER\_STATE\_NOT\_SUPPORTED** in case this API is called with an unsupported power state or the peripheral does not support low power states at all.

」()

**[SWS\_Pwm\_00195]**

┌The API shall report the development error

**PWM\_E\_TRANSITION\_NOT\_POSSIBLE** in case the requested power state cannot be directly reached from the current power state.┐()

**[SWS\_Pwm\_00196]**

┌The API shall report the development error

**PWM\_E\_PERIPHERAL\_NOT\_PREPARED** in case the HW unit has not been previously prepared for the target power state by use of the API

Pwm\_PreparePowerState(). ┐()

**8.3.10 Pwm\_GetCurrentPowerState**

**[SWS\_Pwm\_00177]**

|                           |   |   |
|---------------------------|---|---|
| <b>Service Name</b>       | Pwm_GetCurrentPowerState  |   |
| <b>Syntax</b>             | <pre>Std_ReturnType Pwm_GetCurrentPowerState (     Pwm_PowerStateType* CurrentPowerState,     Pwm_PowerStateRequestResultType* Result )</pre> |   |
| <b>Service ID [hex]</b>   | 0x0a  |   |
| <b>Sync/Async</b>         | Synchronous   |   |
| <b>Reentrancy</b>         | Non Reentrant   |   |
| <b>Parameters (in)</b>    | None  |   |
| <b>Parameters (inout)</b> | None  |   |
| <b>Parameters (out)</b>   | CurrentPower State  | The current power mode of the PWM HW Unit is returned in this parameter   |
|                           | Result  | If the API returns E_OK: PWM_SERVICE_ACCEPTED: Current power mode was returned.<br>If the API returns E_NOT_OK: PWM_NOT_INIT: PWM Module not initialized. |
| <b>Return value</b>       | Std_Return-Type   | E_OK: Mode could be read<br>E_NOT_OK: Service is rejected   |
| <b>Description</b>        | This API returns the current power state of the PWM HW unit.  |   |
| <b>Available via</b>      | Pwm.h   |   |

┐()

**[SWS\_Pwm\_00178]**

┌The API returns the power state of the HW unit.

In case development error reporting is activated: ]()

**[SWS\_Pwm\_00179]**

⌈The API shall report the development error **PWM\_E\_UNINIT** in case this API is called before having initialized the HW unit. ]()

**8.3.11 Pwm\_GetTargetPowerState**

**[SWS\_Pwm\_00180]**

|                           |   |   |
|---------------------------|---|---|
| <b>Service Name</b>       | Pwm_GetTargetPowerState   |   |
| <b>Syntax</b>             | <pre>Std_ReturnType Pwm_GetTargetPowerState (     Pwm_PowerStateType* TargetPowerState,     Pwm_PowerStateRequestResultType* Result )</pre> |   |
| <b>Service ID [hex]</b>   | 0x0b  |   |
| <b>Sync/Async</b>         | Synchronous   |   |
| <b>Reentrancy</b>         | Non Reentrant   |   |
| <b>Parameters (in)</b>    | None  |   |
| <b>Parameters (inout)</b> | None  |   |
| <b>Parameters (out)</b>   | TargetPower State   | The Target power mode of the PWM HW Unit is returned in this parameter  |
|                           | Result  | If the API returns E_OK: PWM_SERVICE_ACCEPTED:Target power mode was returned.<br>If the API returns E_NOT_OK: PWM_NOT_INIT: PWM Module not initialized. |
| <b>Return value</b>       | Std_Return-Type   | E_OK: Mode could be read<br>E_NOT_OK: Service is rejected   |
| <b>Description</b>        | This API returns the Target power state of the PWM HW unit.   |   |
| <b>Available via</b>      | Pwm.h   |   |

]()

**[SWS\_Pwm\_00181]**

⌈The API returns the requested power state of the HW unit. This shall coincide with the current power state if no transition is ongoing.

The API is considered to always succeed except in case of HW failures.

In case development error reporting is activated: ]()

**[SWS\_Pwm\_00182]**

┌The API shall report the development error **PWM\_E\_UNINIT** in case this API is called before having initialized the HW unit. ]()

**8.3.12 Pwm\_PreparePowerState**

[  
**[SWS\_Pwm\_00183]**[

|                           |  |   |
|---------------------------|--|---|
| <b>Service Name</b>       | Pwm_PreparePowerState  |   |
| <b>Syntax</b>             | Std_ReturnType Pwm_PreparePowerState (<br>Pwm_PowerStateType PowerState,<br>Pwm_PowerStateRequestResultType* Result<br>) |   |
| <b>Service ID [hex]</b>   | 0x0c   |   |
| <b>Sync/Async</b>         | Synchronous  |   |
| <b>Reentrancy</b>         | Non Reentrant  |   |
| <b>Parameters (in)</b>    | Power State  | The target power state intended to be attained  |
| <b>Parameters (inout)</b> | None   |   |
| <b>Parameters (out)</b>   | Result   | If the API returns E_OK: PWM_SERVICE_ACCEPTED: PWM Module power state preparation was started.<br>If the API returns E_NOT_OK: PWM_NOT_INIT: PWM Module not initialized. PWM_SEQUENCE_ERROR: wrong API call sequence (Current Power State = Target Power State). PWM_POWER_STATE_NOT_SUPP: PWM Module does not support the requested power state. PWM_TRANS_NOT_POSSIBLE: PWM Module cannot transition directly from the current power state to the requested power state or the HW peripheral is still busy. |
| <b>Return value</b>       | Std_Return-Type  | E_OK: Preparation process started<br>E_NOT_OK: Service is rejected  |
| <b>Description</b>        | This API starts the needed process to allow the PWM HW module to enter the requested power state.                        |   |
| <b>Available via</b>      | Pwm.h  |   |

]()

**[SWS\_Pwm\_00184]**

┌This API initiates all actions needed to enable a HW module to enter the target power state.

The possibility to operate the periphery depends on the power state and the HW features. These properties should be known to the integrator and the decision whether to use the periphery or not is in his responsibility. ]()

**[SWS\_Pwm\_00185]**

「In case the target power state is the same as the current one, no action is executed and the API returns immediately with an E\_OK result.

The responsibility of the preconditions is left to the environment.

In case development error reporting is activated. ]()

**[SWS\_Pwm\_00186]**

「The API shall report the development error **PWM\_E\_UNINIT** in case this API is called before having initialized the HW unit. ]()

**[SWS\_Pwm\_00187]**

「The API shall report the development error **PWM\_E\_POWER\_STATE\_NOT\_SUPPORTED** in case this API is called with an unsupported power state is requested or the peripheral does not support low power states at all. ]()

**[SWS\_Pwm\_00188]**

「The API shall report the development error **PWM\_E\_TRANSITION\_NOT\_POSSIBLE** in case the requested power state cannot be directly reached from the current power state.

All asynchronous operation needed to reach the target power state can be executed in background in the context of Pwm\_Main\_PowerTransitionManager. ]()

**8.3.13 Pwm\_GetVersionInfo**

**[SWS\_Pwm\_00103]**

|                         |  |
|-------------------------|--|
| <b>Service Name</b>     | Pwm_GetVersionInfo   |
| <b>Syntax</b>           | void Pwm_GetVersionInfo (<br>Std_VersionInfoType* versioninfo<br>) |
| <b>Service ID [hex]</b> | 0x08   |
| <b>Sync/Async</b>       | Synchronous  |
| <b>Reentrancy</b>       | Reentrant  |

|                           |   |   |
|---------------------------|---|---|
| <b>Parameters (in)</b>    | None  |   |
| <b>Parameters (inout)</b> | None  |   |
| <b>Parameters (out)</b>   | versioninfo   | Pointer to where to store the version information of this module. |
| <b>Return value</b>       | None  |   |
| <b>Description</b>        | Service returns the version information of this module. |   |
| <b>Available via</b>      | Pwm.h   |   |

()

## 8.4 Callback notifications

Since the PWM Driver is a module on the lowest architectural layer it doesn't provide any call-back functions for lower layer modules.

## 8.5 Scheduled functions

All services offered by the PWM Driver are of synchronous nature, with the exception of the asynchronous power transition management, if so configured. In case the synchronous power transition management is configured, no scheduled API is generated.

### 8.5.1 Pwm\_Main\_PowerTransitionManager

#### [SWS\_Pwm\_00189]

|                         |   |
|-------------------------|---|
| <b>Service Name</b>     | Pwm_Main_PowerTransitionManager   |
| <b>Syntax</b>           | <pre>void Pwm_Main_PowerTransitionManager (     void )</pre>  |
| <b>Service ID [hex]</b> | 0x0d  |
| <b>Description</b>      | This API is cyclically called and supervises the power state transitions, checking for the readiness of the module and issuing the callbacks IoHwAb_Pwm_NotifyReady ForPowerState<Mode> (see PwmPowerStateReadyCbkJef configuration parameter). |
| <b>Available via</b>    | SchM_Pwm.h  |

()

#### [SWS\_Pwm\_00190]



┌ This API executes any non-immediate action needed to finalize a power state transition requested by `Pwm_PreparePowerState().`┐()

**[SWS\_Pwm\_00191]**

┌ The rate of scheduling shall be defined by `Pwm MainSchedulePeriod` and shall be variable, as the function only needs to be called if a transition has been requested.┐()

**[SWS\_Pwm\_00192]**

┌ This API shall also issue callback notifications to the eventually registered users (`IoHwAbs`) as configured, only in case the `asynch` mode is chosen.┐()

**[SWS\_Pwm\_00193]**

┌ In case the PWM module is not initialized, this function shall simply return without any further elaboration. This is needed to avoid to elaborate uninitialized variables. No development error shall be entered, because this condition can easily be verified during the startup phase (tasks started before the initialization is complete).

Rationale: during the startup phase it can happen that the OS already schedules tasks, which call main functions, while some modules are not initialised yet. This is no real error condition, although need handling, i.e. returning without execution.

Although the transition state monitoring functionality is mandatory, the implementation of this API is optional, meaning that if the HW allows for other ways to deliver notification and watch the transition state the implementation of this function can be skipped.┐()

## 8.6 Expected Interfaces

In this chapter all interfaces required from other modules are listed.

### 8.6.1 Mandatory Interfaces

This chapter defines all interfaces which are required to fulfill the core functionality of the module.

As this module is part of the MCAL layer, it access directly to the microcontroller registers and therefore doesn't need any lower interfaces.

### 8.6.2 Optional Interfaces

This chapter defines all interfaces which are required to fulfill an optional functionality of the module.

**[SWS\_Pwm\_00104]**

| <i>API Function</i> | <i>Header File</i> | <i>Description</i>                    |
|---------------------|--------------------|---------------------------------------|
| Det_ReportError     | Det.h              | Service to report development errors. |

]()

### 8.6.3 Configurable interfaces

In this chapter all interfaces are listed where the target function could be configured. The target function is usually a call-back function. The names of these kinds of interfaces are not fixed because they are configurable.

#### [SWS\_Pwm\_00105]

|                           |   |
|---------------------------|---|
| <b>Service Name</b>       | Pwm_Notification_<#Channel>   |
| <b>Syntax</b>             | void Pwm_Notification_<#Channel> (<br>void<br>)   |
| <b>Sync/Async</b>         | Synchronous   |
| <b>Reentrancy</b>         | PWM user implementation dependant   |
| <b>Parameters (in)</b>    | None  |
| <b>Parameters (inout)</b> | None  |
| <b>Parameters (out)</b>   | None  |
| <b>Return value</b>       | None  |
| <b>Description</b>        | The Pwm module shall call the function Pwm_Notification_<#Channel> accordingly to the last call of Pwm_EnableNotification for channel <#Channel>. |
| <b>Available via</b>      | Pwm_Externals.h   |

]()

**[SWS\_Pwm\_00025]** [The Pwm module shall call the function Pwm\_Notification\_<#Channel> accordingly to the last call of Pwm\_EnableNotification and Pwm\_DisableNotification for channel <#Channel>.] (SRS\_SPAL\_00157)

**[SWS\_Pwm\_00026]** [The Pwm module shall reset the interrupt flag associated to the notification Pwm\_Notification\_<#Channel>] (SRS\_SPAL\_12129)

**[SWS\_Pwm\_10115]** [The Pwm module shall provide the functionality of Pwm\_EnableNotification only when the configuration parameter PwmNotificationSupported is ON. ] ()

**[SWS\_Pwm\_20115]** [The Pwm module shall provide the functionality of Pwm\_DisableNotification only when the configuration parameter PwmNotificationSupported is ON. ] ()

**[SWS\_Pwm\_30115]** [The Pwm module shall reset the interrupt flag associated to the notification only when the configuration parameter PwmNotificationSupported is ON. ] ()

**[SWS\_Pwm\_91005]**

|                           |  |
|---------------------------|--|
| <b>Service Name</b>       | IoHwAb_Pwm_NotifyReadyForPowerState<#Mode>   |
| <b>Syntax</b>             | void IoHwAb_Pwm_NotifyReadyForPowerState<#Mode> (<br>void<br>)   |
| <b>Sync/Async</b>         | Synchronous  |
| <b>Reentrancy</b>         | Non Reentrant  |
| <b>Parameters (in)</b>    | None   |
| <b>Parameters (inout)</b> | None   |
| <b>Parameters (out)</b>   | None   |
| <b>Return value</b>       | None   |
| <b>Description</b>        | The API shall be invoked by the PWM Driver when the requested power state preparation for mode <#Mode> is completed. |
| <b>Available via</b>      | IoHwAb_Pwm.h   |

]()

**[SWS\_Pwm\_00199]**

[In case the PWM Driver is configured to support power state management with asynchronous transitions, this API shall be called to signal completion of the power transition preparation phase to the IoHwAbs module.

This is a callback, this API is to be implemented in the IoHwAbs component.]()

## 8.7 API parameter checking

**[SWS\_Pwm\_10051]** [If development error detection for the Pwm module is enabled, and a development error occurs, then the corresponding PWM function shall report the error to the Default Error Tracer. ] (SRS\_BSW\_00323, SRS\_BSW\_00386)

**[SWS\_Pwm\_20051]** [If development error detection for the Pwm module is enabled, and a development error occurs, then the corresponding PWM function shall skip the

desired functionality in order to avoid any corruptions of data or hardware registers leaving the function without any actions. ] (SRS\_BSW\_00323, SRS\_BSW\_00386)

**[SWS\_Pwm\_00117]** [If development error detection for the Pwm module is enabled: if any function (except Pwm\_Init) is called before Pwm\_Init has been called, the called function shall raise development error `PWM_E_UNINIT`. ] (SRS\_BSW\_00406, SRS\_BSW\_00323, SRS\_BSW\_00386)

**[SWS\_Pwm\_00045]** [If development error detection for the Pwm module is enabled: The API `Pwm_SetPeriodAndDuty()` shall check if the given PWM channel is of the channel class type `PWM_VARIABLE_PERIOD`. If this is not the case the development error `PWM_E_PERIOD_UNCHANGEABLE` shall be called. ] (SRS\_BSW\_00323, SRS\_BSW\_00386)

**[SWS\_Pwm\_00047]** [If development error detection for the Pwm module is enabled: the PWM functions shall check the parameter `ChannelNumber` and raise development error `PWM_E_PARAM_CHANNEL` if the parameter `ChannelNumber` is invalid. ] (SRS\_BSW\_00323, SRS\_BSW\_00386)

## 9 Sequence diagrams

### 9.1 Initialization

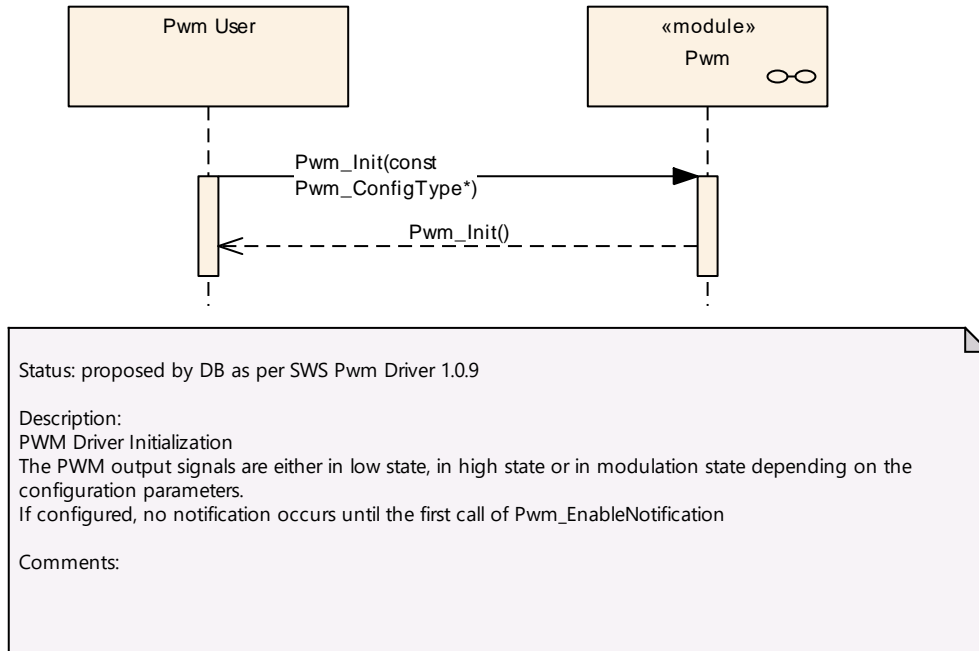

**Figure 2: Pwm initialization**

### 9.2 De-initialization

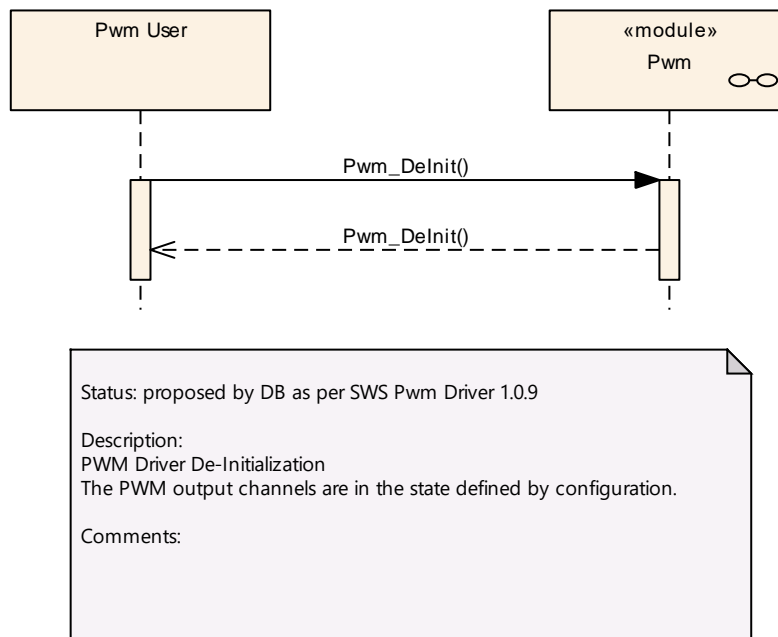

**Figure 3: Pwm de-initialization**

### 9.3 Setting the duty cycle

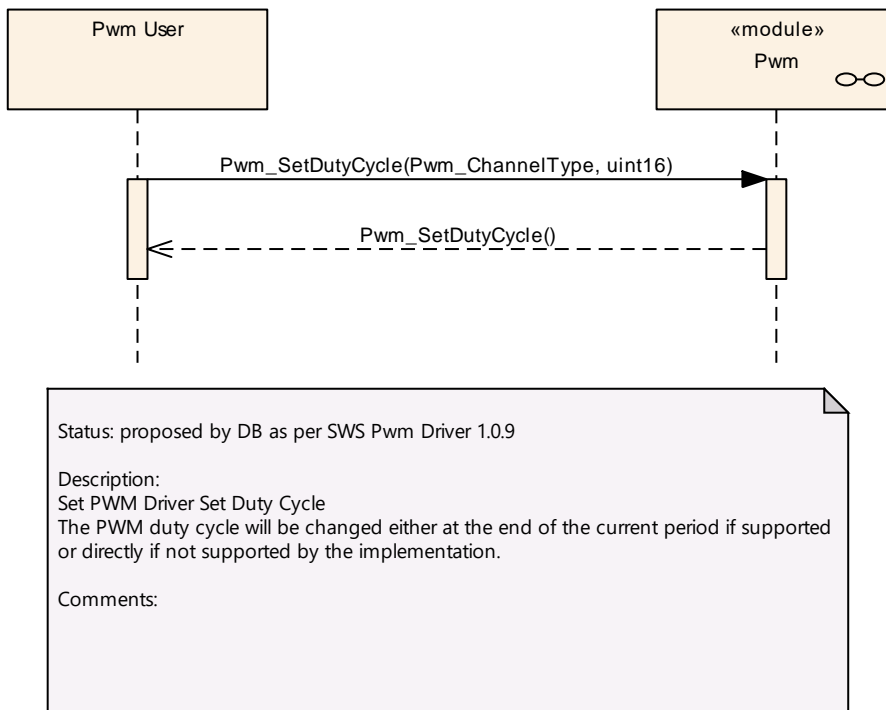

**Figure 4: Setting the duty cycle**

### 9.4 Setting the period and the duty

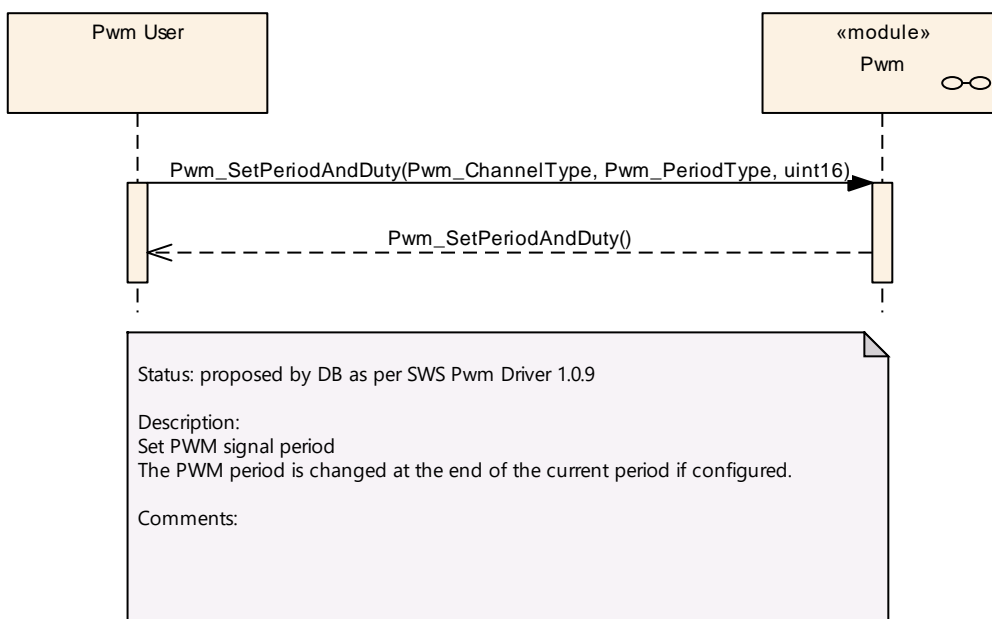

**Figure 5: Setting period and duty cycle**

### 9.5 Setting the PWM output to idle

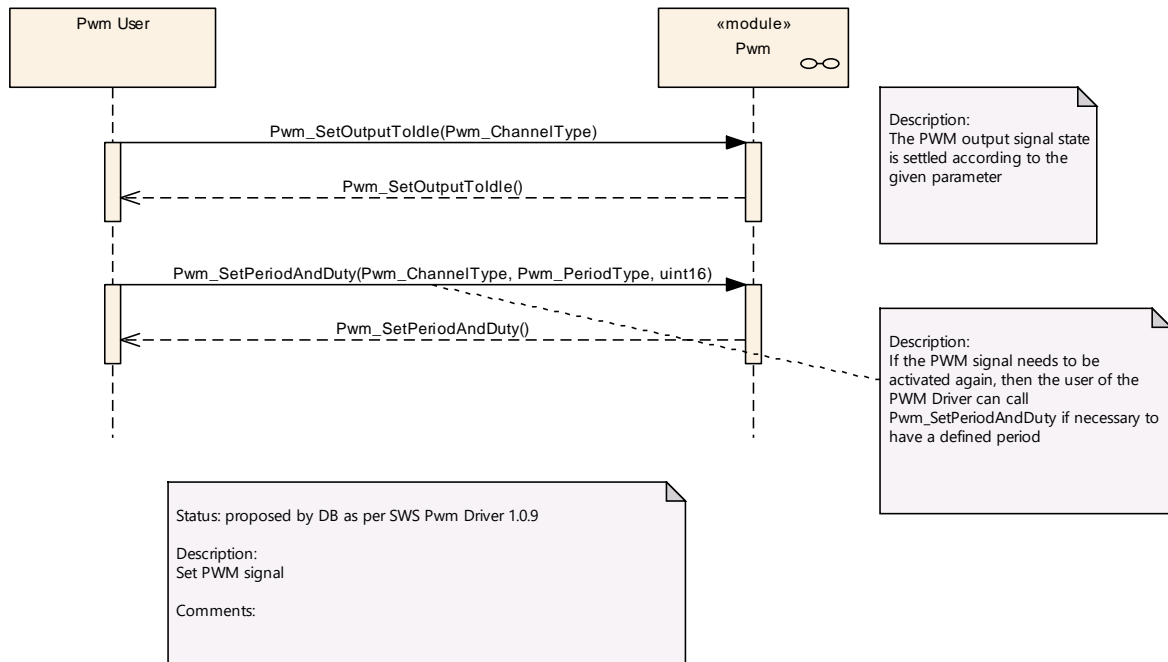

Figure 6: Setting Pwm output to idle

### 9.6 Getting the PWM Output state

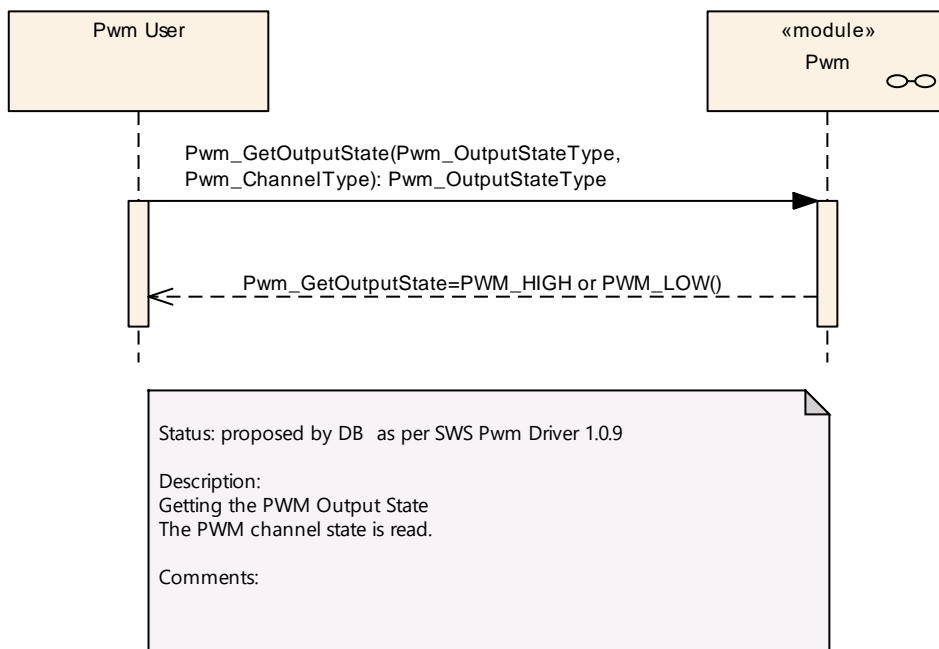
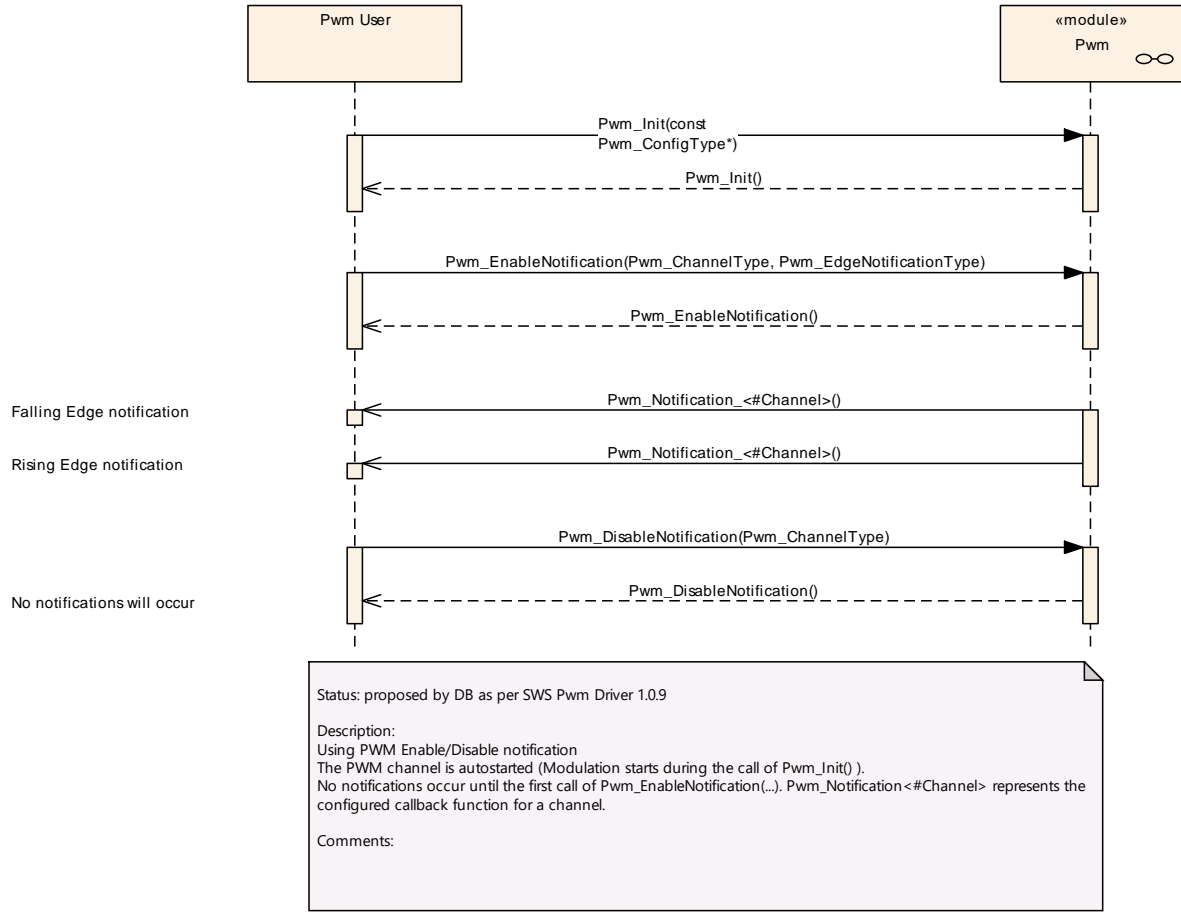

Figure 7: Getting Pwm output state

### 9.7 Using the PWM notifications



**Figure 8: Using Pwm notifications**



## 10 Configuration specification

In general, this chapter defines configuration parameters and their clustering into containers. In order to support the specification Chapter 10.1 describes fundamentals. It also specifies a template (table) you shall use for the parameter specification. We intend to leave Chapter 10.1 in the specification to guarantee comprehension.

Chapter 10.2 specifies the structure (containers) and the parameters of the module PWM Driver.

Chapter 10.3 specifies published information of the module PWM Driver.

### 10.1 How to read this chapter

For details refer to the chapter 10.1 “Introduction to configuration specification” in *SWS\_BSWGeneral*.

### 10.2 Containers and configuration parameters

The following chapters summarize all configuration parameters. The detailed meanings of the parameters describe Chapters [Functional specification](#) and Chapter [API specification](#).

**[SWS\_Pwm\_00203]** [The PWM module shall reject configurations with partition mappings which are not supported by the implementation.]()

#### 10.2.1 Pwm

|                                   |   |
|-----------------------------------|---|
| <b>SWS Item</b>                   | [ECUC_Pwm_00148]                                      |
| <b>Module Name</b>                | Pwm   |
| <b>Description</b>                | Configuration of Pwm (Pulse Width Modulation) module. |
| <b>Post-Build Variant Support</b> | true  |
| <b>Supported Config Variants</b>  | VARIANT-POST-BUILD, VARIANT-PRE-COMPILE               |

| Included Containers               |              |  |
|-----------------------------------|--------------|--|
| Container Name                    | Multiplicity | Scope / Dependency   |
| PwmChannelConfigSet               | 1            | This container contains the configuration parameters and sub containers of the AUTOSAR Pwm module. |
| PwmConfigurationOfOpt-ApiServices | 1            | --   |

|            |   |    |
|------------|---|----|
| PwmGeneral | 1 | -- |
|------------|---|----|

### 10.2.2 PwmGeneral

|                                 |                  |
|---------------------------------|------------------|
| <b>SWS Item</b>                 | [ECUC_Pwm_00004] |
| <b>Container Name</b>           | PwmGeneral       |
| <b>Parent Container</b>         | Pwm              |
| <b>Description</b>              | --               |
| <b>Configuration Parameters</b> |                  |

|                                  |  |    |              |
|----------------------------------|--|----|--------------|
| <b>SWS Item</b>                  | [ECUC_Pwm_00131]   |    |              |
| <b>Parameter Name</b>            | PwmDevErrorDetect  |    |              |
| <b>Parent Container</b>          | PwmGeneral   |    |              |
| <b>Description</b>               | <p>Switches the development error detection and notification on or off.</p> <ul style="list-style-type: none"> <li>true: detection and notification is enabled.</li> <li>false: detection and notification is disabled.</li> </ul> |    |              |
| <b>Multiplicity</b>              | 1  |    |              |
| <b>Type</b>                      | EcucBooleanParamDef  |    |              |
| <b>Default value</b>             | false  |    |              |
| <b>Post-Build Variant Value</b>  | false  |    |              |
| <b>Value Configuration Class</b> | <b>Pre-compile time</b>  | X  | All Variants |
|                                  | <b>Link time</b>   | -- |              |
|                                  | <b>Post-build time</b>   | -- |              |
| <b>Scope / Dependency</b>        | scope: local   |    |              |

|                         |  |
|-------------------------|--|
| <b>SWS Item</b>         | [ECUC_Pwm_00132]   |
| <b>Parameter Name</b>   | PwmDutycycleUpdatedEndperiod   |
| <b>Parent Container</b> | PwmGeneral   |
| <b>Description</b>      | Switch for enabling the update of the duty cycle parameter at the end of the current period. TRUE: update of duty cycle is done at the end of period of currently generated waveform (current waveform is finished). FALSE: update of duty cycle is done immediately (just after service call, current waveform is cut). |
| <b>Multiplicity</b>     | 1  |
| <b>Type</b>             | EcucBooleanParamDef  |

|                                  |                         |    |              |
|----------------------------------|-------------------------|----|--------------|
| <b>Default value</b>             | --                      |    |              |
| <b>Post-Build Variant Value</b>  | false                   |    |              |
| <b>Value Configuration Class</b> | <b>Pre-compile time</b> | X  | All Variants |
|                                  | <b>Link time</b>        | -- |              |
|                                  | <b>Post-build time</b>  | -- |              |
| <b>Scope / Dependency</b>        | scope: local            |    |              |

|                                  |   |    |              |
|----------------------------------|---|----|--------------|
| <b>SWS Item</b>                  | [ECUC_Pwm_00139]  |    |              |
| <b>Parameter Name</b>            | PwmIndex  |    |              |
| <b>Parent Container</b>          | PwmGeneral  |    |              |
| <b>Description</b>               | Specifies the InstanceId of this module instance. If only one instance is present it shall have the Id 0. |    |              |
| <b>Multiplicity</b>              | 1   |    |              |
| <b>Type</b>                      | EcucIntegerParamDef   |    |              |
| <b>Range</b>                     | 0 .. 4294967295   |    |              |
| <b>Default value</b>             | --  |    |              |
| <b>Post-Build Variant Value</b>  | false   |    |              |
| <b>Value Configuration Class</b> | <b>Pre-compile time</b>   | X  | All Variants |
|                                  | <b>Link time</b>  | -- |              |
|                                  | <b>Post-build time</b>  | -- |              |
| <b>Scope / Dependency</b>        | scope: local  |    |              |

|                         |  |  |  |
|-------------------------|--|--|--|
| <b>SWS Item</b>         | [ECUC_Pwm_00142]   |  |  |
| <b>Parameter Name</b>   | PwmLowPowerStatesSupport   |  |  |
| <b>Parent Container</b> | PwmGeneral   |  |  |
| <b>Description</b>      | Adds / removes all power state management related APIs (PWM_SetPowerState, PWM_GetCurrentPowerState, PWM_GetTargetPowerState, PWM_PreparePowerState, PWM_Main_PowerTransitionManager), indicating if the HW offers low power state management. |  |  |
| <b>Multiplicity</b>     | 0..1   |  |  |
| <b>Type</b>             | EcucBooleanParamDef  |  |  |
| <b>Default value</b>    | false  |  |  |

|   |                         |    |              |
|---|-------------------------|----|--------------|
| <b>Post-Build Variant Multiplicity</b>  | false                   |    |              |
| <b>Post-Build Variant Value</b>         | false                   |    |              |
| <b>Multiplicity Configuration Class</b> | <b>Pre-compile time</b> | X  | All Variants |
|   | <b>Link time</b>        | -- |              |
|   | <b>Post-build time</b>  | -- |              |
| <b>Value Configuration Class</b>        | <b>Pre-compile time</b> | X  | All Variants |
|   | <b>Link time</b>        | -- |              |
|   | <b>Post-build time</b>  | -- |              |
| <b>Scope / Dependency</b>               | scope: local            |    |              |

|                                  |   |    |              |
|----------------------------------|---|----|--------------|
| <b>SWS Item</b>                  | [ECUC_Pwm_00133]  |    |              |
| <b>Parameter Name</b>            | PwmNotificationSupported                                |    |              |
| <b>Parent Container</b>          | PwmGeneral  |    |              |
| <b>Description</b>               | Switch to indicate that the notifications are supported |    |              |
| <b>Multiplicity</b>              | 1   |    |              |
| <b>Type</b>                      | EcucBooleanParamDef                                     |    |              |
| <b>Default value</b>             | --  |    |              |
| <b>Post-Build Variant Value</b>  | false   |    |              |
| <b>Value Configuration Class</b> | <b>Pre-compile time</b>                                 | X  | All Variants |
|                                  | <b>Link time</b>  | -- |              |
|                                  | <b>Post-build time</b>                                  | -- |              |
| <b>Scope / Dependency</b>        | scope: local  |    |              |

|                         |  |  |  |
|-------------------------|--|--|--|
| <b>SWS Item</b>         | [ECUC_Pwm_00134]   |  |  |
| <b>Parameter Name</b>   | PwmPeriodUpdatedEndperiod  |  |  |
| <b>Parent Container</b> | PwmGeneral   |  |  |
| <b>Description</b>      | Switch for enabling the update of the period parameter at the end of the current period. TRUE: update of period/duty cycle is done at the end of period of currently generated waveform (current waveform is finished). FALSE: update of |  |  |

|                                  |   |    |              |
|----------------------------------|---|----|--------------|
|                                  | period/duty cycle is done immediately (just after service call, current waveform is cut). |    |              |
| <b>Multiplicity</b>              | 1   |    |              |
| <b>Type</b>                      | EcucBooleanParamDef   |    |              |
| <b>Default value</b>             | --  |    |              |
| <b>Post-Build Variant Value</b>  | false   |    |              |
| <b>Value Configuration Class</b> | <b>Pre-compile time</b>   | X  | All Variants |
|                                  | <b>Link time</b>  | -- |              |
|                                  | <b>Post-build time</b>  | -- |              |
| <b>Scope / Dependency</b>        | scope: local  |    |              |

|   |   |    |              |
|---|---|----|--------------|
| <b>SWS Item</b>                         | [ECUC_Pwm_00143]  |    |              |
| <b>Parameter Name</b>                   | PwmPowerStateAsynchTransitionMode   |    |              |
| <b>Parent Container</b>                 | PwmGeneral  |    |              |
| <b>Description</b>                      | Enables / disables support of the PWM Driver to the asynchronous power state transition.                                      |    |              |
| <b>Multiplicity</b>                     | 0..1  |    |              |
| <b>Type</b>                             | EcucBooleanParamDef   |    |              |
| <b>Default value</b>                    | false   |    |              |
| <b>Post-Build Variant Multiplicity</b>  | false   |    |              |
| <b>Post-Build Variant Value</b>         | false   |    |              |
| <b>Multiplicity Configuration Class</b> | <b>Pre-compile time</b>   | X  | All Variants |
|   | <b>Link time</b>  | -- |              |
|   | <b>Post-build time</b>  | -- |              |
| <b>Value Configuration Class</b>        | <b>Pre-compile time</b>   | X  | All Variants |
|   | <b>Link time</b>  | -- |              |
|   | <b>Post-build time</b>  | -- |              |
| <b>Scope / Dependency</b>               | scope: local<br>dependency: This parameter shall only be configured if the parameter PwmLowPowerStatesSupport is set to true. |    |              |

|   |  |    |              |
|---|--|----|--------------|
| <b>SWS Item</b>                         | [ECUC_Pwm_00149]   |    |              |
| <b>Parameter Name</b>                   | PwmEcucPartitionRef  |    |              |
| <b>Parent Container</b>                 | PwmGeneral   |    |              |
| <b>Description</b>                      | Maps the PWM driver to zero or multiple ECUC partitions to make the driver API available in the according partition. |    |              |
| <b>Multiplicity</b>                     | 0..*   |    |              |
| <b>Type</b>                             | Reference to EcucPartition   |    |              |
| <b>Post-Build Variant Multiplicity</b>  | true   |    |              |
| <b>Post-Build Variant Value</b>         | true   |    |              |
| <b>Multiplicity Configuration Class</b> | <b>Pre-compile time</b>  | X  | All Variants |
|   | <b>Link time</b>   | -- |              |
|   | <b>Post-build time</b>   | -- |              |
| <b>Value Configuration Class</b>        | <b>Pre-compile time</b>  | X  | All Variants |
|   | <b>Link time</b>   | -- |              |
|   | <b>Post-build time</b>   | -- |              |
| <b>Scope / Dependency</b>               | scope: ECU   |    |              |

|   |   |    |              |
|---|---|----|--------------|
| <b>SWS Item</b>                         | [ECUC_Pwm_00150]  |    |              |
| <b>Parameter Name</b>                   | PwmKernelEcucPartitionRef   |    |              |
| <b>Parent Container</b>                 | PwmGeneral  |    |              |
| <b>Description</b>                      | Maps the PWM kernel to zero or one ECUC partitions to assign the driver kernel to a certain core. The ECUC partition referenced is a subset of the ECUC partitions where the PWM driver is mapped to. |    |              |
| <b>Multiplicity</b>                     | 0..1  |    |              |
| <b>Type</b>                             | Reference to EcucPartition  |    |              |
| <b>Post-Build Variant Multiplicity</b>  | true  |    |              |
| <b>Post-Build Variant Value</b>         | true  |    |              |
| <b>Multiplicity Configuration Class</b> | <b>Pre-compile time</b>   | X  | All Variants |
|   | <b>Link time</b>  | -- |              |
|   | <b>Post-build time</b>  | -- |              |
|   | <b>Pre-compile time</b>   | X  | All Variants |

|                                  |                        |    |  |
|----------------------------------|------------------------|----|--|
| <b>Value Configuration Class</b> | <b>Link time</b>       | -- |  |
|                                  | <b>Post-build time</b> | -- |  |
| <b>Scope / Dependency</b>        | scope: ECU             |    |  |

| <b>Included Containers</b> |                     |   |
|----------------------------|---------------------|---|
| <b>Container Name</b>      | <b>Multiplicity</b> | <b>Scope / Dependency</b>   |
| PwmPower-StateConfig       | 0..*                | Each instance of this parameter defines a power state and the callback to be called when this power state is reached. |

**[SWS\_Pwm\_CONSTR\_00001]** 「 The ECUC partitions referenced by PwmKernelEcucPartitionRef shall be a subset of the ECUC partitions referenced by PwmEcucPartitionRef. 」()

**[SWS\_Pwm\_CONSTR\_00002]** 「 If PwmEcucPartitionRef references one or more ECUC partitions, PwmKernelEcucPartitionRef shall have a multiplicity of one and reference one of these ECUC partitions as well. 」()

### 10.2.3 PwmPowerStateConfig

|                                 |   |
|---------------------------------|---|
| <b>SWS Item</b>                 | [ECUC_Pwm_00144]  |
| <b>Container Name</b>           | PwmPowerStateConfig   |
| <b>Parent Container</b>         | PwmGeneral  |
| <b>Description</b>              | Each instance of this parameter defines a power state and the callback to be called when this power state is reached. |
| <b>Configuration Parameters</b> |   |

|                         |  |
|-------------------------|--|
| <b>SWS Item</b>         | [ECUC_Pwm_00146]   |
| <b>Parameter Name</b>   | PwmPowerState  |
| <b>Parent Container</b> | PwmPowerStateConfig  |
| <b>Description</b>      | Each instance of this parameter describes a different power state supported by the PWM HW. It should be defined by the HW supplier and used by the PWMDriver to reference specific HW configurations which set the PWM HW module in the referenced power state.<br>At least the power mode corresponding to full power state shall be always configured. |

|                                  |   |    |              |
|----------------------------------|---|----|--------------|
| <b>Multiplicity</b>              | 1   |    |              |
| <b>Type</b>                      | EcucIntegerParamDef (Symbolic Name generated for this parameter)  |    |              |
| <b>Range</b>                     | 0 .. 18446744073709551615   |    |              |
| <b>Default value</b>             | --  |    |              |
| <b>Post-Build Variant Value</b>  | false   |    |              |
| <b>Value Configuration Class</b> | <b>Pre-compile time</b>   | X  | All Variants |
|                                  | <b>Link time</b>  | -- |              |
|                                  | <b>Post-build time</b>  | -- |              |
| <b>Scope / Dependency</b>        | scope: local<br>dependency: This parameter shall only be configured if the parameter PwmLowPowerStatesSupport is set to true. |    |              |

|                                  |   |    |              |
|----------------------------------|---|----|--------------|
| <b>SWS Item</b>                  | [ECUC_Pwm_00145]  |    |              |
| <b>Parameter Name</b>            | PwmPowerStateReadyCbkJef  |    |              |
| <b>Parent Container</b>          | PwmPowerStateConfig   |    |              |
| <b>Description</b>               | Each instance of this parameter contains a reference to a power mode callback defined in a CDD or IoHwAbs component.          |    |              |
| <b>Multiplicity</b>              | 1   |    |              |
| <b>Type</b>                      | EcucFunctionNameDef   |    |              |
| <b>Default value</b>             | --  |    |              |
| <b>Regular Expression</b>        | --  |    |              |
| <b>Post-Build Variant Value</b>  | false   |    |              |
| <b>Value Configuration Class</b> | <b>Pre-compile time</b>   | X  | All Variants |
|                                  | <b>Link time</b>  | -- |              |
|                                  | <b>Post-build time</b>  | -- |              |
| <b>Scope / Dependency</b>        | scope: local<br>dependency: This parameter shall only be configured if the parameter PwmLowPowerStatesSupport is set to true. |    |              |

|                               |
|-------------------------------|
| <b>No Included Containers</b> |
|-------------------------------|



### 10.2.4 PwmChannel

|                                 |   |
|---------------------------------|---|
| <b>SWS Item</b>                 | [ECUC_Pwm_00027]                            |
| <b>Container Name</b>           | PwmChannel                                  |
| <b>Parent Container</b>         | PwmChannelConfigSet                         |
| <b>Description</b>              | Configuration of an individual PWM channel. |
| <b>Configuration Parameters</b> |   |

|   |   |   |                     |
|---|---|---|---------------------|
| <b>SWS Item</b>                         | [ECUC_Pwm_00136]  |   |                     |
| <b>Parameter Name</b>                   | PwmChannelClass   |   |                     |
| <b>Parent Container</b>                 | PwmChannel  |   |                     |
| <b>Description</b>                      | Class of PWM Channel.<br>ImplementationType: Pwm_ChannelClassType |   |                     |
| <b>Multiplicity</b>                     | 0..1  |   |                     |
| <b>Type</b>                             | EcucEnumerationParamDef   |   |                     |
| <b>Range</b>                            | PWM_FIXED_PERIOD  | Only the duty cycle can be changed.   |                     |
|   | PWM_FIXED_PERIOD_SHIFTED  | Only the duty cycle can be changed. The period is shifted (only if supported by hardware) |                     |
|   | PWM_VARIABLE_PERIOD   | Duty Cycle and period can be changed.   |                     |
| <b>Post-Build Variant Multiplicity</b>  | true  |   |                     |
| <b>Post-Build Variant Value</b>         | true  |   |                     |
| <b>Multiplicity Configuration Class</b> | <b>Pre-compile time</b>   | X   | VARIANT-PRE-COMPILE |
|   | <b>Link time</b>  | --  |                     |
|   | <b>Post-build time</b>  | X   | VARIANT-POST-BUILD  |
| <b>Value Configuration Class</b>        | <b>Pre-compile time</b>   | X   | VARIANT-PRE-COMPILE |
|   | <b>Link time</b>  | --  |                     |
|   | <b>Post-build time</b>  | X   | VARIANT-POST-BUILD  |
| <b>Scope / Dependency</b>               | scope: local  |   |                     |

|                         |                  |
|-------------------------|------------------|
| <b>SWS Item</b>         | [ECUC_Pwm_00137] |
| <b>Parameter Name</b>   | PwmChannelId     |
| <b>Parent Container</b> | PwmChannel       |

|                                  |   |    |              |
|----------------------------------|---|----|--------------|
| <b>Description</b>               | Channel Id of the PWM channel. This value will be assigned to the symbolic name derived of the PwmChannel container short name. |    |              |
| <b>Multiplicity</b>              | 1   |    |              |
| <b>Type</b>                      | EcucIntegerParamDef (Symbolic Name generated for this parameter)  |    |              |
| <b>Range</b>                     | 0 .. 4294967295   |    |              |
| <b>Default value</b>             | --  |    |              |
| <b>Post-Build Variant Value</b>  | false   |    |              |
| <b>Value Configuration Class</b> | <b>Pre-compile time</b>   | X  | All Variants |
|                                  | <b>Link time</b>  | -- |              |
|                                  | <b>Post-build time</b>  | -- |              |
| <b>Scope / Dependency</b>        | scope: local  |    |              |

|                                  |   |    |                     |
|----------------------------------|---|----|---------------------|
| <b>SWS Item</b>                  | [ECUC_Pwm_00138]  |    |                     |
| <b>Parameter Name</b>            | PwmDutycycleDefault   |    |                     |
| <b>Parent Container</b>          | PwmChannel  |    |                     |
| <b>Description</b>               | Value of duty cycle used for Initialization 0, represents 0% 0x8000 represents 100% |    |                     |
| <b>Multiplicity</b>              | 1   |    |                     |
| <b>Type</b>                      | EcucIntegerParamDef   |    |                     |
| <b>Range</b>                     | 0 .. 32768  |    |                     |
| <b>Default value</b>             | --  |    |                     |
| <b>Post-Build Variant Value</b>  | true  |    |                     |
| <b>Value Configuration Class</b> | <b>Pre-compile time</b>   | X  | VARIANT-PRE-COMPILE |
|                                  | <b>Link time</b>  | -- |                     |
|                                  | <b>Post-build time</b>  | X  | VARIANT-POST-BUILD  |
| <b>Scope / Dependency</b>        | scope: local  |    |                     |

|                         |   |  |  |
|-------------------------|---|--|--|
| <b>SWS Item</b>         | [ECUC_Pwm_00122]  |  |  |
| <b>Parameter Name</b>   | PwmIdleState  |  |  |
| <b>Parent Container</b> | PwmChannel  |  |  |
| <b>Description</b>      | The parameter PWM_IDLE_STATE represents the output state of the PWM after the signal is stopped (e.g. call of Pwm_SetOutputToldle). |  |  |

|                                  |                         |  |                     |
|----------------------------------|-------------------------|--|---------------------|
| <b>Multiplicity</b>              | 1                       |  |                     |
| <b>Type</b>                      | EcucEnumerationParamDef |  |                     |
| <b>Range</b>                     | PWM_HIGH                | The PWM channel output will be set to high ( 3 or 5 V ) in idle state. |                     |
|                                  | PWM_LOW                 | The PWM channel output will be set to low ( 0 V ) in idle state.       |                     |
| <b>Post-Build Variant Value</b>  | true                    |  |                     |
| <b>Value Configuration Class</b> | <b>Pre-compile time</b> | X  | VARIANT-PRE-COMPILE |
|                                  | <b>Link time</b>        | --   |                     |
|                                  | <b>Post-build time</b>  | X  | VARIANT-POST-BUILD  |
| <b>Scope / Dependency</b>        | scope: local            |  |                     |

|   |                                      |    |                     |
|---|--------------------------------------|----|---------------------|
| <b>SWS Item</b>                         | [ECUC_Pwm_00123]                     |    |                     |
| <b>Parameter Name</b>                   | PwmNotification                      |    |                     |
| <b>Parent Container</b>                 | PwmChannel                           |    |                     |
| <b>Description</b>                      | Definition of the Callback function. |    |                     |
| <b>Multiplicity</b>                     | 0..1                                 |    |                     |
| <b>Type</b>                             | EcucFunctionNameDef                  |    |                     |
| <b>Default value</b>                    | "NULL"                               |    |                     |
| <b>Regular Expression</b>               | --                                   |    |                     |
| <b>Post-Build Variant Multiplicity</b>  | true                                 |    |                     |
| <b>Post-Build Variant Value</b>         | true                                 |    |                     |
| <b>Multiplicity Configuration Class</b> | <b>Pre-compile time</b>              | X  | VARIANT-PRE-COMPILE |
|   | <b>Link time</b>                     | -- |                     |
|   | <b>Post-build time</b>               | X  | VARIANT-POST-BUILD  |
| <b>Value Configuration Class</b>        | <b>Pre-compile time</b>              | X  | VARIANT-PRE-COMPILE |
|   | <b>Link time</b>                     | -- |                     |
|   | <b>Post-build time</b>               | X  | VARIANT-POST-BUILD  |
| <b>Scope / Dependency</b>               | scope: local                         |    |                     |

|                       |                  |
|-----------------------|------------------|
| <b>SWS Item</b>       | [ECUC_Pwm_00124] |
| <b>Parameter Name</b> | PwmPeriodDefault |

|                                  |   |    |                     |
|----------------------------------|---|----|---------------------|
| <b>Parent Container</b>          | PwmChannel  |    |                     |
| <b>Description</b>               | Value of period used for Initialization.(in seconds). |    |                     |
| <b>Multiplicity</b>              | 1   |    |                     |
| <b>Type</b>                      | EcucFloatParamDef                                     |    |                     |
| <b>Range</b>                     | [0 .. INF]  |    |                     |
| <b>Default value</b>             | --  |    |                     |
| <b>Post-Build Variant Value</b>  | true  |    |                     |
| <b>Value Configuration Class</b> | <b>Pre-compile time</b>                               | X  | VARIANT-PRE-COMPILE |
|                                  | <b>Link time</b>                                      | -- |                     |
|                                  | <b>Post-build time</b>                                | X  | VARIANT-POST-BUILD  |
| <b>Scope / Dependency</b>        | scope: local  |    |                     |

|                                  |  |  |                     |
|----------------------------------|--|--|---------------------|
| <b>SWS Item</b>                  | [ECUC_Pwm_00125]                                   |  |                     |
| <b>Parameter Name</b>            | PwmPolarity  |  |                     |
| <b>Parent Container</b>          | PwmChannel   |  |                     |
| <b>Description</b>               | Defines the starting polarity of each PWM channel. |  |                     |
| <b>Multiplicity</b>              | 1  |  |                     |
| <b>Type</b>                      | EcucEnumerationParamDef                            |  |                     |
| <b>Range</b>                     | PWM_HIGH   | The PWM channel output is high at the beginning of the cycle and then goes low when the duty count is reached. |                     |
|                                  | PWM_LOW  | The PWM channel output is low at the beginning of the cycle and then goes high when the duty count is reached. |                     |
| <b>Post-Build Variant Value</b>  | true   |  |                     |
| <b>Value Configuration Class</b> | <b>Pre-compile time</b>                            | X  | VARIANT-PRE-COMPILE |
|                                  | <b>Link time</b>                                   | --   |                     |
|                                  | <b>Post-build time</b>                             | X  | VARIANT-POST-BUILD  |
| <b>Scope / Dependency</b>        | scope: local                                       |  |                     |

|                         |                            |  |  |
|-------------------------|----------------------------|--|--|
| <b>SWS Item</b>         | [ECUC_Pwm_00151]           |  |  |
| <b>Parameter Name</b>   | PwmChannelEcucPartitionRef |  |  |
| <b>Parent Container</b> | PwmChannel                 |  |  |

|   |   |    |              |
|---|---|----|--------------|
| <b>Description</b>                      | Maps a PWM channel to zero or multiple ECUC partitions to limit the access to this channel. The ECUC partitions referenced are a subset of the ECUC partitions where the PWM driver is mapped to. |    |              |
| <b>Multiplicity</b>                     | 0..*  |    |              |
| <b>Type</b>                             | Reference to EcucPartition  |    |              |
| <b>Post-Build Variant Multiplicity</b>  | true  |    |              |
| <b>Post-Build Variant Value</b>         | true  |    |              |
| <b>Multiplicity Configuration Class</b> | <b>Pre-compile time</b>   | X  | All Variants |
|   | <b>Link time</b>  | -- |              |
|   | <b>Post-build time</b>  | -- |              |
| <b>Value Configuration Class</b>        | <b>Pre-compile time</b>   | X  | All Variants |
|   | <b>Link time</b>  | -- |              |
|   | <b>Post-build time</b>  | -- |              |
| <b>Scope / Dependency</b>               | scope: ECU  |    |              |

|                                  |   |    |                     |
|----------------------------------|---|----|---------------------|
| <b>SWS Item</b>                  | [ECUC_Pwm_00147]  |    |                     |
| <b>Parameter Name</b>            | PwmMcuClockReferencePoint                                       |    |                     |
| <b>Parent Container</b>          | PwmChannel  |    |                     |
| <b>Description</b>               | This parameter contains reference to the McuClockReferencePoint |    |                     |
| <b>Multiplicity</b>              | 1   |    |                     |
| <b>Type</b>                      | Reference to McuClockReferencePoint                             |    |                     |
| <b>Post-Build Variant Value</b>  | true  |    |                     |
| <b>Value Configuration Class</b> | <b>Pre-compile time</b>   | X  | VARIANT-PRE-COMPILE |
|                                  | <b>Link time</b>  | -- |                     |
|                                  | <b>Post-build time</b>  | X  | VARIANT-POST-BUILD  |
| <b>Scope / Dependency</b>        | scope: ECU  |    |                     |

**No Included Containers**

**[SWS\_Pwm\_CONSTR\_00003]** 「If PwmEcucPartitionRef references one or more ECUC partitions, PwmChannelEcucPartitionRef shall have a multiplicity of greater than zero and reference one or several of these ECUC partitions as well.」()

### 10.2.5 PwmChannelConfigSet

|                                 |  |
|---------------------------------|--|
| <b>SWS Item</b>                 | [ECUC_Pwm_00140]   |
| <b>Container Name</b>           | PwmChannelConfigSet  |
| <b>Parent Container</b>         | Pwm  |
| <b>Description</b>              | This container contains the configuration parameters and sub containers of the AUTOSAR Pwm module. |
| <b>Configuration Parameters</b> |  |

|                            |                     |   |
|----------------------------|---------------------|---|
| <b>Included Containers</b> |                     |   |
| <b>Container Name</b>      | <b>Multiplicity</b> | <b>Scope / Dependency</b>                   |
| PwmChannel                 | 1..*                | Configuration of an individual PWM channel. |

### 10.2.6 PwmConfigurationOfOptApiServices

|                                 |                                  |
|---------------------------------|----------------------------------|
| <b>SWS Item</b>                 | [ECUC_Pwm_00126]                 |
| <b>Container Name</b>           | PwmConfigurationOfOptApiServices |
| <b>Parent Container</b>         | Pwm                              |
| <b>Description</b>              | --                               |
| <b>Configuration Parameters</b> |                                  |

|                                  |  |    |              |
|----------------------------------|--|----|--------------|
| <b>SWS Item</b>                  | [ECUC_Pwm_00141]                                       |    |              |
| <b>Parameter Name</b>            | PwmDelnitApi   |    |              |
| <b>Parent Container</b>          | PwmConfigurationOfOptApiServices                       |    |              |
| <b>Description</b>               | Adds / removes the service Pwm_Delnit() from the code. |    |              |
| <b>Multiplicity</b>              | 1  |    |              |
| <b>Type</b>                      | EcucBooleanParamDef                                    |    |              |
| <b>Default value</b>             | --   |    |              |
| <b>Post-Build Variant Value</b>  | false  |    |              |
| <b>Value Configuration Class</b> | <b>Pre-compile time</b>                                | X  | All Variants |
|                                  | <b>Link time</b>                                       | -- |              |
|                                  | <b>Post-build time</b>                                 | -- |              |
| <b>Scope / Dependency</b>        | scope: local   |    |              |

|                                  |                                  |    |              |
|----------------------------------|----------------------------------|----|--------------|
| <b>SWS Item</b>                  | [ECUC_Pwm_00127]                 |    |              |
| <b>Parameter Name</b>            | PwmGetOutputState                |    |              |
| <b>Parent Container</b>          | PwmConfigurationOfOptApiServices |    |              |
| <b>Description</b>               | --                               |    |              |
| <b>Multiplicity</b>              | 1                                |    |              |
| <b>Type</b>                      | EcucBooleanParamDef              |    |              |
| <b>Default value</b>             | --                               |    |              |
| <b>Post-Build Variant Value</b>  | false                            |    |              |
| <b>Value Configuration Class</b> | <b>Pre-compile time</b>          | X  | All Variants |
|                                  | <b>Link time</b>                 | -- |              |
|                                  | <b>Post-build time</b>           | -- |              |
| <b>Scope / Dependency</b>        | scope: local                     |    |              |

|                                  |                                  |    |              |
|----------------------------------|----------------------------------|----|--------------|
| <b>SWS Item</b>                  | [ECUC_Pwm_00128]                 |    |              |
| <b>Parameter Name</b>            | PwmSetDutyCycle                  |    |              |
| <b>Parent Container</b>          | PwmConfigurationOfOptApiServices |    |              |
| <b>Description</b>               | --                               |    |              |
| <b>Multiplicity</b>              | 1                                |    |              |
| <b>Type</b>                      | EcucBooleanParamDef              |    |              |
| <b>Default value</b>             | --                               |    |              |
| <b>Post-Build Variant Value</b>  | false                            |    |              |
| <b>Value Configuration Class</b> | <b>Pre-compile time</b>          | X  | All Variants |
|                                  | <b>Link time</b>                 | -- |              |
|                                  | <b>Post-build time</b>           | -- |              |
| <b>Scope / Dependency</b>        | scope: local                     |    |              |

|                         |                                  |  |  |
|-------------------------|----------------------------------|--|--|
| <b>SWS Item</b>         | [ECUC_Pwm_00129]                 |  |  |
| <b>Parameter Name</b>   | PwmSetOutputToldle               |  |  |
| <b>Parent Container</b> | PwmConfigurationOfOptApiServices |  |  |
| <b>Description</b>      | --                               |  |  |
| <b>Multiplicity</b>     | 1                                |  |  |
| <b>Type</b>             | EcucBooleanParamDef              |  |  |

|                                  |                         |    |              |
|----------------------------------|-------------------------|----|--------------|
| <b>Default value</b>             | --                      |    |              |
| <b>Post-Build Variant Value</b>  | false                   |    |              |
| <b>Value Configuration Class</b> | <b>Pre-compile time</b> | X  | All Variants |
|                                  | <b>Link time</b>        | -- |              |
|                                  | <b>Post-build time</b>  | -- |              |
| <b>Scope / Dependency</b>        | scope: local            |    |              |

|                                  |                                  |    |              |
|----------------------------------|----------------------------------|----|--------------|
| <b>SWS Item</b>                  | [ECUC_Pwm_00130]                 |    |              |
| <b>Parameter Name</b>            | PwmSetPeriodAndDuty              |    |              |
| <b>Parent Container</b>          | PwmConfigurationOfOptApiServices |    |              |
| <b>Description</b>               | --                               |    |              |
| <b>Multiplicity</b>              | 1                                |    |              |
| <b>Type</b>                      | EcucBooleanParamDef              |    |              |
| <b>Default value</b>             | --                               |    |              |
| <b>Post-Build Variant Value</b>  | false                            |    |              |
| <b>Value Configuration Class</b> | <b>Pre-compile time</b>          | X  | All Variants |
|                                  | <b>Link time</b>                 | -- |              |
|                                  | <b>Post-build time</b>           | -- |              |
| <b>Scope / Dependency</b>        | scope: local                     |    |              |

|                                  |  |    |              |
|----------------------------------|--|----|--------------|
| <b>SWS Item</b>                  | [ECUC_Pwm_00135]   |    |              |
| <b>Parameter Name</b>            | PwmVersionInfoApi  |    |              |
| <b>Parent Container</b>          | PwmConfigurationOfOptApiServices                             |    |              |
| <b>Description</b>               | Switch to indicate that the Pwm_ GetVersionInfo is supported |    |              |
| <b>Multiplicity</b>              | 1  |    |              |
| <b>Type</b>                      | EcucBooleanParamDef  |    |              |
| <b>Default value</b>             | false  |    |              |
| <b>Post-Build Variant Value</b>  | false  |    |              |
| <b>Value Configuration Class</b> | <b>Pre-compile time</b>                                      | X  | All Variants |
|                                  | <b>Link time</b>   | -- |              |
|                                  | <b>Post-build time</b>                                       | -- |              |
| <b>Scope / Dependency</b>        | scope: local   |    |              |



No Included Containers

### 10.3 Published Information

For details refer to the chapter 10.3 “Published Information” in *SWS\_BSWGeneral*.

## 11 Not applicable requirements

**[SWS\_Pwm\_NA\_00153]** [These requirements are not applicable to this

specification.] (SRS\_BSW\_00159, SRS\_BSW\_00167, SRS\_BSW\_00170, SRS\_BSW\_00419, SRS\_BSW\_00383, SRS\_BSW\_00375, SRS\_BSW\_00416, SRS\_BSW\_00168, SRS\_BSW\_00423, SRS\_BSW\_00424, SRS\_BSW\_00425, SRS\_BSW\_00426, SRS\_BSW\_00427, SRS\_BSW\_00428, SRS\_BSW\_00429, SRS\_BSW\_00432, SRS\_BSW\_00433, SRS\_BSW\_00417, SRS\_BSW\_00161, SRS\_BSW\_00162, SRS\_BSW\_00005, SRS\_BSW\_00415, SRS\_BSW\_00164, SRS\_BSW\_00325, SRS\_BSW\_00342, SRS\_BSW\_00160, SRS\_BSW\_00007, SRS\_BSW\_00300, SRS\_BSW\_00413, SRS\_BSW\_00347, SRS\_BSW\_00305, SRS\_BSW\_00307, SRS\_BSW\_00310, SRS\_BSW\_00373, SRS\_BSW\_00327, SRS\_BSW\_00335, SRS\_BSW\_00350, SRS\_BSW\_00408, SRS\_BSW\_00410, SRS\_BSW\_00348, SRS\_BSW\_00353, SRS\_BSW\_00301, SRS\_BSW\_00302, SRS\_BSW\_00328, SRS\_BSW\_00312, SRS\_BSW\_00006, SRS\_BSW\_00357, SRS\_BSW\_00377, SRS\_BSW\_00304, SRS\_BSW\_00378, SRS\_BSW\_00306, SRS\_BSW\_00308, SRS\_BSW\_00309, SRS\_BSW\_00358, SRS\_BSW\_00414, SRS\_BSW\_00359, SRS\_BSW\_00360, SRS\_BSW\_00330, SRS\_BSW\_00331, SRS\_BSW\_00009, SRS\_BSW\_00401, SRS\_BSW\_00172, SRS\_BSW\_00010, SRS\_BSW\_00333, SRS\_BSW\_00003, SRS\_BSW\_00341, SRS\_BSW\_00334, SRS\_SPAL\_12267, SRS\_SPAL\_12461, SRS\_SPAL\_12462, SRS\_SPAL\_12463, SRS\_SPAL\_12068, SRS\_SPAL\_12069, SRS\_SPAL\_12169, SRS\_SPAL\_12075, SRS\_SPAL\_12064, SRS\_SPAL\_12067, SRS\_SPAL\_12077, SRS\_SPAL\_12078, SRS\_SPAL\_12092, SRS\_SPAL\_12265, SRS\_Pwm\_12379)