

<b>Document Title</b>	Overview of Functional Safety Measures in AUTOSAR
<b>Document Owner</b>	AUTOSAR
<b>Document Responsibility</b>	AUTOSAR
<b>Document Identification No</b>	664

<b>Document Status</b>	published
<b>Part of AUTOSAR Standard</b>	Classic Platform
<b>Part of Standard Release</b>	R23-11

<b>Document Change History</b>			
<b>Date</b>	<b>Release</b>	<b>Changed by</b>	<b>Description</b>
2023-11-23	R23-11	AUTOSAR Release Management	<ul style="list-style-type: none"> <li>• Fixed AUTOSAR specification references</li> <li>• Changes in image and tables layout</li> </ul>
2022-11-24	R22-11	AUTOSAR Release Management	<ul style="list-style-type: none"> <li>• No content changes</li> </ul>
2021-11-25	R21-11	AUTOSAR Release Management	<ul style="list-style-type: none"> <li>• No content changes</li> </ul>
2020-11-30	R20-11	AUTOSAR Release Management	<ul style="list-style-type: none"> <li>• No content changes</li> </ul>
2019-11-28	R19-11	AUTOSAR Release Management	<ul style="list-style-type: none"> <li>• Removed Duplicated IDs</li> <li>• Changed Document Status from Final to published</li> </ul>
2018-10-31	4.4.0	AUTOSAR Release Management	<ul style="list-style-type: none"> <li>• Editorial changes</li> </ul>
2016-11-30	4.3.0	AUTOSAR Release Management	<ul style="list-style-type: none"> <li>• New Chapter: Use of AUTOSAR features for functional safety is based on Chapters 4.2 and 4.3 from document TR_SafetyConceptStatusReport_233</li> <li>• Minor corrections / clarifications / editorial changes</li> </ul>



△

2015-07-31	4.2.2	AUTOSAR Release Management	<ul style="list-style-type: none"><li>• New Chapter: Hardware Diagnostics covers Core Test and RAM Test.</li><li>• Minor corrections / clarifications / editorial changes.</li></ul>
2014-10-31	4.2.1	AUTOSAR Release Management	<ul style="list-style-type: none"><li>• Initial Release</li></ul>

## Disclaimer

This work (specification and/or software implementation) and the material contained in it, as released by AUTOSAR, is for the purpose of information only. AUTOSAR and the companies that have contributed to it shall not be liable for any use of the work.

The material contained in this work is protected by copyright and other types of intellectual property rights. The commercial exploitation of the material contained in this work requires a license to such intellectual property rights.

This work may be utilized or reproduced without any modification, in any form or by any means, for informational purposes only. For any other purpose, no part of the work may be utilized or reproduced, in any form or by any means, without permission in writing from the publisher.

The work has been developed for automotive applications only. It has neither been developed, nor tested for non-automotive applications.

The word AUTOSAR and the AUTOSAR logo are registered trademarks.

## Contents

1	Introduction	7
1.1	Disclaimer	7
1.2	Scope	7
1.3	Purpose	8
1.4	Intended Audience	8
2	Functional Safety Mechanisms	9
2.1	Memory Partitioning	9
2.1.1	Fault Models	10
2.1.2	Description	10
2.1.2.1	Application Software	11
2.1.2.2	OS Applications	12
2.1.2.3	Communication and Code Sharing	13
2.1.2.4	Memory Partitioning within Application Software	14
2.1.2.5	Memory Partitioning within Software Components	15
2.1.2.6	Implementation of Memory Partitioning	17
2.1.3	Detection and Reaction	20
2.1.4	Limitations	20
2.1.5	References to AUTOSAR Documents	21
2.1.6	References to ISO26262	21
2.2	Timing Monitoring	22
2.2.1	Fault Models	22
2.2.2	Description	23
2.2.2.1	Supervised Entities	23
2.2.2.2	Watchdog Manager	23
2.2.2.3	Timing Protection of the Operating System	25
2.2.3	Detection and Reaction	26
2.2.4	Limitations	27
2.2.5	References to AUTOSAR Documents	28
2.2.6	References to ISO26262	28
2.3	Logical Supervision	29
2.3.1	Fault Models	29
2.3.2	Description	29
2.3.3	Detection and Reaction	31
2.3.4	Limitations	33
2.3.5	References to AUTOSAR Documents	33
2.3.6	References to ISO26262	33
2.4	End-2-End Protection	33
2.4.1	Fault Models	34
2.4.2	Description	35
2.4.2.1	End-2-End Profiles	36
2.4.2.2	End-2-End State Machine	40
2.4.2.3	Integration of the End-2-End Protection Library	41
2.4.2.4	End-2-End Protection Wrapper	42



2.4.2.5	Transmission Manager	43
2.4.2.6	COM End-2-End Callout	44
2.4.2.7	RTE Data Transformer	45
2.4.3	Detection and Reaction	47
2.4.4	Limitations	47
2.4.5	References to AUTOSAR Documents	48
2.4.6	References to ISO26262	48
3	Functional Safety Measures	49
3.1	Functional Safety Measures of AUTOSAR	49
3.2	Traceability	50
3.3	Development Measures and the Evolution of the Standard	50
3.4	Functional Safety Measures not delivered by AUTOSAR	51
3.5	Safety related Extensions of Methodology and Templates	52
3.6	Safety Use Case	52
3.7	Use of AUTOSAR features for functional safety	53
3.7.1	Timing Related Features	53
3.7.1.1	Features related to the provision of synchronized time bases	53
3.7.1.2	Features related to synchronization of processing of asynchronous processing units	58
3.7.1.3	Features to allow time deterministic implementation of applications	60
3.7.1.4	Features related to protection against timing violation	64
3.7.2	E-Gas Monitoring Related Features	66
3.7.2.1	Communication protections against corruption and loss of data	66
3.7.2.2	Priority access to SPI bus	68
3.7.2.3	Testing and monitoring of I/O data and I/O HW	68
3.7.2.4	Ability to make an AUTOSAR application compatible to the e-Gas monitoring Concept	69
4	Hardware Diagnostics	71
4.1	Core Test	71
4.1.1	Fault Models	71
4.1.2	Description	72
4.1.3	Detection and Reaction	72
4.1.4	Limitations	72
4.1.5	References to AUTOSAR Documents	73
4.1.6	References to ISO26262	73
4.2	RAM Test	73
4.2.1	Fault Models	74
4.2.2	Description	74
4.2.3	Detection and Reaction	75
4.2.4	Limitations	75
4.2.5	References to AUTOSAR Documents	75
4.2.6	References to ISO26262	76

- A Appendix 77
  - A.1 Acronyms and abbreviations . . . . . 77
- B Related Documentation 78

# 1 Introduction

Functional safety is a system characteristic which is taken into account from the beginning, as it may influence system design decisions. Therefore AUTOSAR specifications include requirements related to functional safety.

Aspects such as complexity of the system design can be relevant for the achievement of functional safety in the automotive field.

Software is one parameter that can influence complexity on system level. New techniques and concepts for software development can be used in order to minimize complexity and therefore can ease the achievement of functional safety.

AUTOSAR supports the development of safety-related systems by offering safety measures and mechanisms. However AUTOSAR is not a complete safe solution.

The use of AUTOSAR does not imply [1, ISO 26262] compliance. It is still possible to build unsafe systems using the AUTOSAR safety measures and mechanisms.

## 1.1 Disclaimer

This explanatory document represents the functional safety measures and mechanisms of the latest release of AUTOSAR. Some of the described mechanisms and measures may be implemented differently or may not be available in previous releases. The user of this document shall always consult the applicable referenced documents.

## 1.2 Scope

The content of this document is structured into separate chapters as follows:

**Functional Safety Mechanisms:** This chapter contains AUTOSAR functional safety mechanisms related to freedom from interference between AUTOSAR SW-Cs.

- **Memory:** Partitioning mechanisms of AUTOSAR with the context of Application Software development and deployment.
- **Timing:** Temporal Program Flow Monitoring mechanisms using the Watchdog Manager and Timing Protection mechanisms using the Operating System.
- **Execution:** Logical Supervision mechanisms using the Watchdog Manager.
- **Exchange of Information:** Communication fault detection mechanisms using the End-2-End Library and Extensions.

**Functional Safety Measures:** This chapter contains topics related to the development of safety-relevant systems. The following items are covered:

- Functional Safety Measures of AUTOSAR, such as Traceability, Development Measures and the Evolution of the Standard.
- Functional Safety Measures not delivered by AUTOSAR.
- Safety Use Case: An exemplary safety related system using AUTOSAR based on the guided tour example Front Light Management.
- Safety Extensions: How safety requirements can be expressed within the AUTOSAR models and documents by means of the AUTOSAR meta-model.

Hardware Diagnostics: This chapter contains topics related to the premise, that the provided functionality of the microcontroller can be trusted. The following items are covered:

- Core Test.
- RAM Test.

### 1.3 Purpose

Information about AUTOSAR functional safety mechanisms and measures is currently distributed throughout the referenced documentation. Unless one knows how functional safety mechanisms are supported and where the necessary information is specifically located, it is difficult to evaluate how a safety-relevant system can be implemented using AUTOSAR efficiently.

This explanatory document summarizes the key points related to functional safety in AUTOSAR and explains how the functional safety mechanisms and measures can be used.

Note: This document supersedes the AUTOSAR document "Technical Safety Concept Status Report", ID: 233.

### 1.4 Intended Audience

This document gives an overview of the functional safety measures and mechanisms of AUTOSAR and their implementation to those involved in the development of safety-relevant (ECU) systems. Therefore this document is intended for the users of AUTOSAR, including people involved in safety analysis.

## 2 Functional Safety Mechanisms

Modern ECUs contain highly modular embedded software, which can consist of both non-safety-related and safety-related software components, which perform functions with different ASIL ratings.

According to ISO 26262<sup>1</sup>, if the embedded software consists of software components with different ASIL ratings, then either the entire software must be developed according to the highest ASIL, or freedom from interference shall be ensured for software components with a higher ASIL rating from elements with a lower ASIL rating.

Furthermore, the ISO 26262<sup>2</sup> standard provides examples for faults, which cause interference between software components. The faults are grouped as follows:

- Memory
- Timing
- Execution
- Exchange of Information

During the course of the following chapter, an overview of AUTOSAR functional safety mechanisms<sup>3</sup> is given. Those mechanisms assist with the prevention, detection and mitigation of hardware and software faults to ensure freedom from interference between software components.

Note: AUTOSAR functional safety mechanisms are used to support the development of safety-related systems. Therefore, functional safety mechanisms (software and hardware) are safety-related and must be developed and integrated accordingly.

### 2.1 Memory Partitioning

A modular implementation of embedded systems that consists of both safety-related software components of different ASILs or of safety-related and non-safety-related software components is facilitated by AUTOSAR features that support freedom from interference between such software components.

Software Components which are developed according to a low ASIL rating may interfere by wrongfully accessing memory regions of software components with a higher ASIL rating. An execution of software components in separate memory regions or memory partitions supports the prevention of such memory access violations. Please see section [2.1.2.6](#) for further details.

---

<sup>1</sup> [ISO 26262-6 7.4.8] Coexistence

<sup>2</sup>[ISO 26262-6, Annex D] Freedom from interference between software elements.

<sup>3</sup>In the context of this document, functional safety mechanisms are a concrete product part, such as memory protection. They are considered as specialization of functional safety measures, which also include process steps, like a review. This definition is in line with the definition given in ISO 26262 for these terms.

The features described in this chapter are part of the OS and the RTE functionality, which are required to enable groups of SW-Cs to run in separate memory partitions, in order to provide freedom from interference between software components.

### 2.1.1 Fault Models

According to ISO 26262<sup>4</sup>, the following memory-related effects of faults can be considered as a cause for interference between software components:

- Corruption of content.
- Read or write access to memory allocated to another software element.
- Inconsistent data (e.g. due to update during data fetch).
- Stack overflow or underflow.

The functional safety mechanism Memory Partitioning provides protection by means of restricting access to memory and memory-mapped hardware. Memory partitioning means that OS-Applications reside in different memory areas (partitions) that are protected from each other. In particular, code executing in one partition cannot modify memory of a different partition. Moreover, memory partitioning enables to protect read-only memory segments (e.g. code execution), as well as to protect memory-mapped hardware.

The memory partitioning and user/supervisor-modes related features address the following goal: Supporting freedom from interference between software components by means of memory partitioning (e.g. memory-related faults in SW-Cs do not propagate to other software modules and SW-Cs executed in user-mode have restricted access to CPU instructions like e.g. reconfiguration).

### 2.1.2 Description

Memory Partitioning is an extension of the RTE and the OS, which is described in the AUTOSAR Specification as "One Partition will be implemented using one OS-Application"<sup>5</sup> and "SW-Cs grouped in separate user-mode memory partitions"<sup>6</sup>.

During the course of this chapter, this extension will be described as the relationship of Runnables, Tasks, Software Components and OS-Applications in the context of the AUTOSAR Methodology.

---

<sup>4</sup> [ISO 26262-6, Annex D] D.2.3 Memory

<sup>5</sup>CP\_TPS\_ECUConfiguration[2], V3.5.0, R4.1 Rev 3, Page 154, ECUC\_EcuC\_00005

<sup>6</sup> Requirements on AUTOSAR Features, V1.2.1, R4.1 Rev 2, Chapter 4.11 Safety

**2.1.2.1 Application Software**

In the AUTOSAR Architecture, Application Software is located above the RTE and consists of interconnected AUTOSAR Software Components, which atomically encapsulate parts of the Application Software functionality.

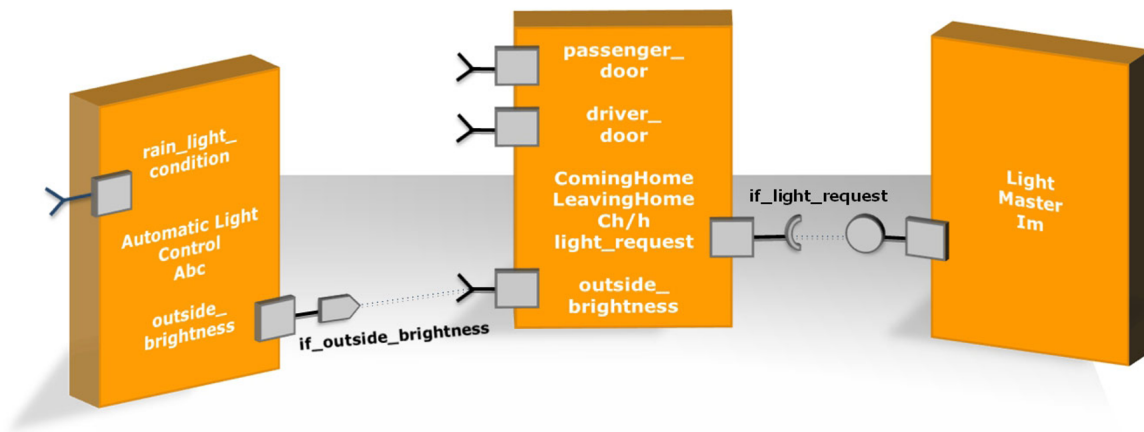

**Figure 2.1: Application Software**

AUTOSAR Software Components are hardware-independent, so they can be integrated onto any available ECU Hardware. To facilitate the inter- and intra-ECU information exchange, AUTOSAR Software Components communicate exclusively over the RTE.

AUTOSAR Software Components contain a number of Functions and Variables, which provide the internal functionality. The internal structure of an AUTOSAR Software Component, its Variables and Function Calls, is hidden from the public view via the header files. Only the external RTE calls are presented at the public interface.

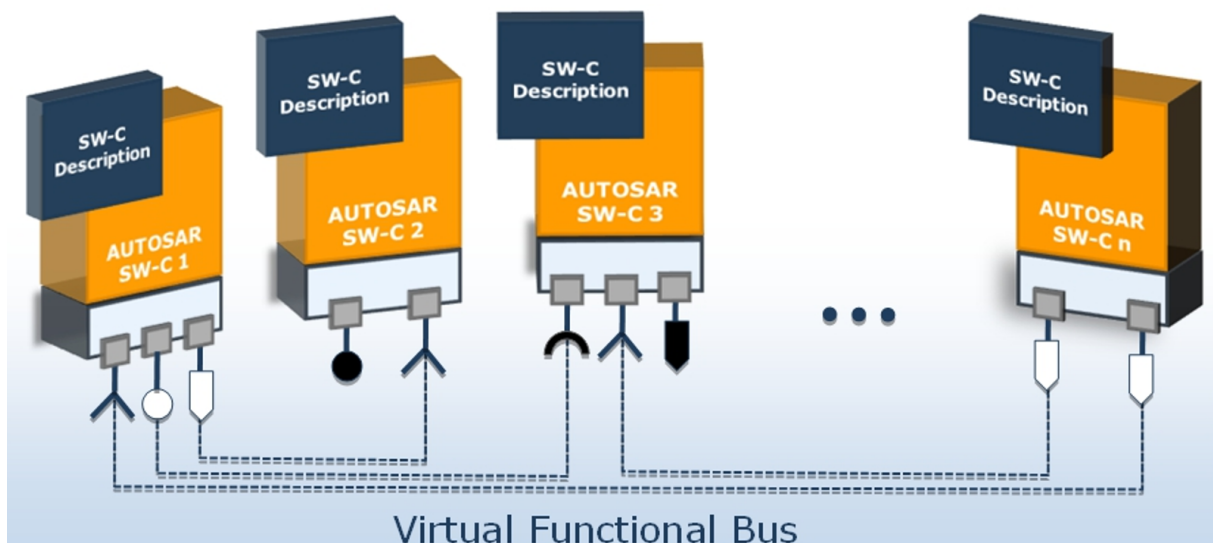
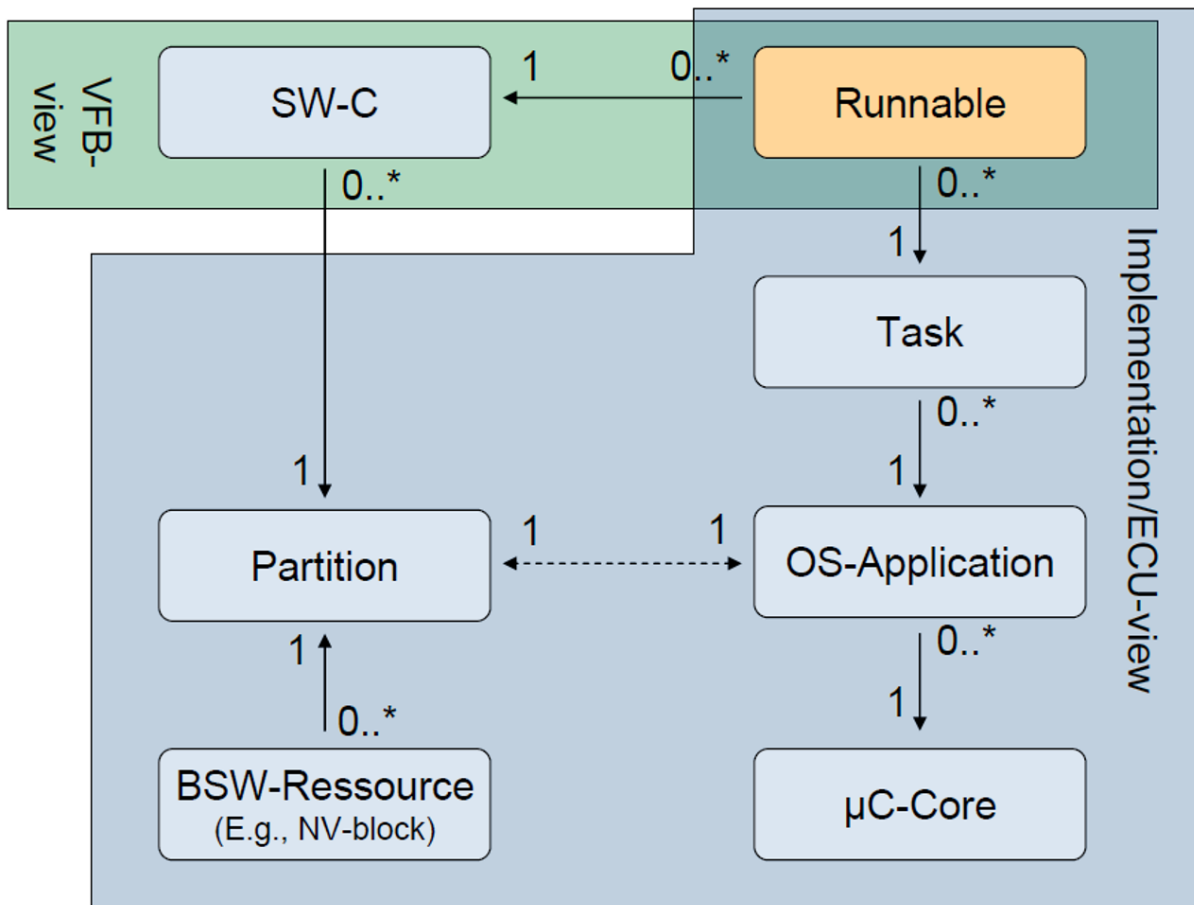

**Figure 2.2: Software Components**

AUTOSAR Software Components also contain functions, which must be invoked at runtime. Those C-functions are referred to as Runnables in AUTOSAR.

Runnables cannot be executed by themselves; they must be assigned to executable entities of the operating system. Such an assignment can be performed by inserting function calls of Runnables into OS-Task bodies.

Runnables are then executed cyclically and/or event-driven in the context of their caller OS-Task. The assignment of Runnables to Tasks is performed according to [Figure 2.3](#) and [Figure 2.4](#).

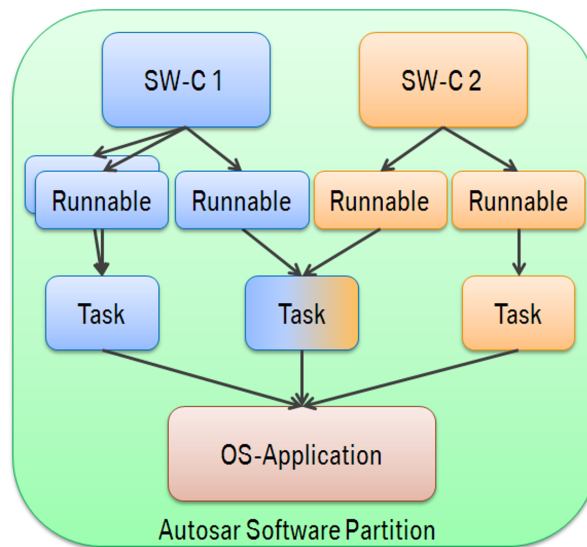

**Figure 2.3: AUTOSAR Layered Software Architecture - Mapping of Runnables**

**2.1.2.2 OS Applications**

[Figure 2.4](#) presents an interpretation of the relations from [Figure 2.3](#). Runnables from AUTOSAR Software Components are assigned to OS-Tasks according to this diagram.





**Figure 2.4: Mapping of Software Components to OS-Applications**

CP\_EXP\_LayeredSoftwareArchitecture[3], V3.4.0, R4.1 Rev 3, Page 105

AUTOSAR OS-Applications are collections of Operating System objects such as Tasks, ISRs, Schedule Tables, Counters and Alarms that form a cohesive functional unit. All objects which belong to the same OS-Application have access to each other.

The Operating System objects within an OS-Application may belong to different AUTOSAR Software Components. The RTE implements a memory area which is accessible by all members of the OS-Application without restrictions to facilitate communication between the SW-Cs efficiently.

There are two classes of OS-Applications:

1. "Trusted OS-Applications are allowed to run with monitoring or protection features disabled at runtime. They may have unrestricted access to memory and the Operating System module's API. Trusted OS-Applications need not have their timing behavior enforced at runtime. They are allowed to run in privileged mode when supported by the processor."
2. "Non-Trusted OS-Applications are not allowed to run with monitoring or protection features disabled at runtime. They have restricted access to memory, restricted access to the Operating System module's API and have their timing behaviour enforced at runtime. They are not allowed to run in privileged mode when supported by the processor."<sup>7</sup>

### 2.1.2.3 Communication and Code Sharing

According to [Figure 2.4](#) and [Figure 2.3](#), an OS-Application can contain multiple AUTOSAR Software Components and associated Runtables. Runtables are only al-

<sup>7</sup>CP\_SWS\_OS[4], V5.3.0 R4.1 Rev 3, Chapter 7.6.1

lowed to directly access variables and to perform function calls within their respective Software Component.

Internal Function Calls and Variables of a Software Component are not publically known by other Software Components, as their definitions are not presented by the header files of the external interface.

Therefore, a direct communication via variables and the execution of Code of other Software Components is not intended.

In [Figure 2.5](#), this is illustrated by the example of code-sharing, which is only allowed within the Software Component and not between Software Components of one OS-Application. Communication with other Software Components shall be performed via the RTE. Runnable 4 may not execute functions belonging to SW-C 2.2.

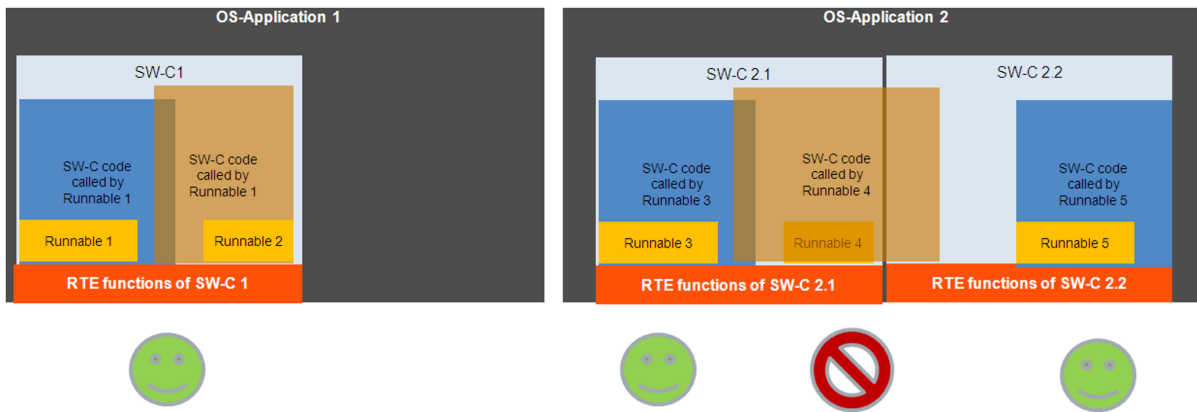

**Figure 2.5: Code-Sharing within an OS-Application**

### 2.1.2.4 Memory Partitioning within Application Software

Application Software in an AUTOSAR ECU can consist of safety-related and non-safety-related Software Components. Freedom from interference between Software Components with different ASIL ratings shall be ensured according to the requirements of ISO 26262<sup>8</sup>.

The AUTOSAR Operating System provides freedom from interference for memory-related faults by placing OS-Applications into separate memory regions. This mechanism is called Memory Partitioning. OS-Applications are protected from each other, as code executing in the Memory Partition of one OS-Application cannot modify other memory regions. The corresponding requirements from the AUTOSAR OS specification are presented in [Table 2.1](#).

<sup>8</sup> [ISO 26262-6 7.4.8] Coexistence

Req. ID	Requirement Text
[SWS_Os_00207]	The Operating System module shall prevent write access to the OS-Application's private data sections from other non-trusted OS-Applications.
[SWS_Os_00355]	The Operating System module shall prevent write access to all private stacks of Tasks/Category 2 ISRs of an OS-Application from other non-trusted OS-Applications.
[SWS_Os_00356]	The Operating System module shall prevent write access to all private data sections of a Task/Category 2 ISR of an OS-Application from other non-trusted OS-Applications.

**Table 2.1: AUTOSAR OS - Memory Partitioning for OS-Applications**  
 Specification of Operating System, V5.3.0 R4.1 Rev 3

Application Software can consist of Software Components with different ASIL ratings. However, Software Components with different ASIL ratings should not be assigned to the same OS-Application. Memory Partitioning does not provide freedom from interference between Software Components which are assigned to the same OS-Application. The Operating System only prevents other OS-Applications from performing improper accesses. A faulty Software Component would not be prevented from modifying memory areas of other Software Components within the same OS-Application.

Note: Please consult the subsequent section for details on Task-level partitioning.

### 2.1.2.5 Memory Partitioning within Software Components

A Mixed-ASIL Software Component could consist of Runnables with different ASIL ratings and therefore requires an execution environment which supports freedom from interference between those Runnables. An execution of different Runnables of one Software Component in different Memory Partitions is not possible due to the following:

Memory Partitioning is performed at the level of OS-Applications. According to [Figure 2.3](#) and [Figure 2.4](#) however, a Software Component can only be assigned to one OS-Application and therefore has only one Memory Partition. Also, Runnables of a Software Component can only be called by the Tasks of one OS-Application.

As shown in [Figure 2.6](#), Runnables of a Software Component cannot be distributed to Tasks of multiple OS-Applications.

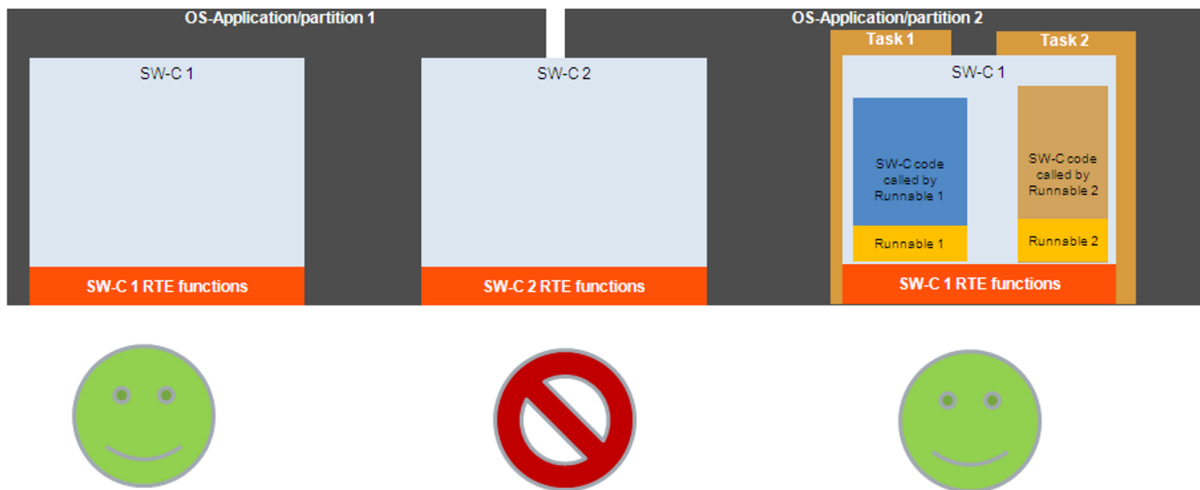

**Figure 2.6: SWCs vs. Partitions**

Memory Partitioning cannot be used to separate Runnables within the same SW-C. If it is necessary to have a Software Component comprise Runnables with different ASIL-ratings and an independent execution with freedom from interference is required for those Runnables, then memory partitioning at OS-Application level is not sufficient, memory partitioning has to be performed at Task-level. This approach is shown in [Figure 2.7](#).

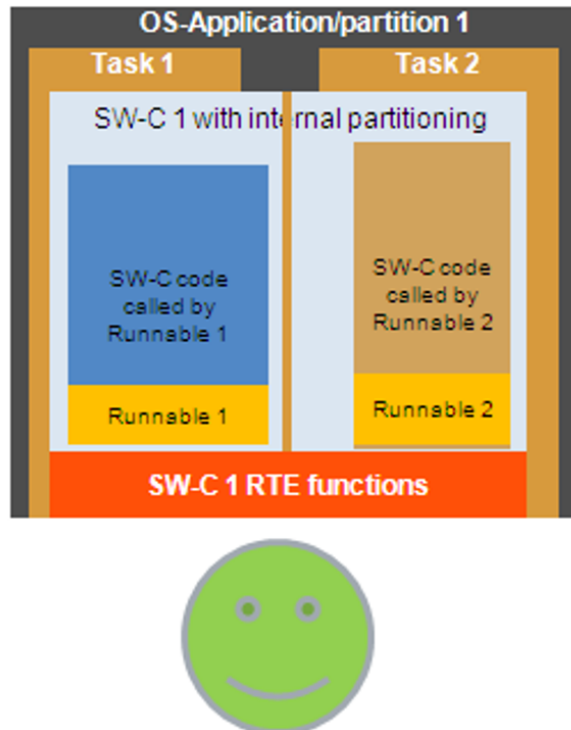

**Figure 2.7: Task Partitioning**

Requirements related to Memory Partitioning at Task-level are listed in the AUTOSAR OS specification in [Table 2.2](#). The use of the weak word "may" shows that an implementation of Task-level partitioning is optional for the AUTOSAR OS. Therefore, not every AUTOSAR OS implementation may support Task-level Memory Partitioning.

Req. ID	Requirement Text
[SWS_Os_00208]	The Operating System module may prevent write access to the private stack of Tasks/Category 2 ISRs of a non-trusted application from all other Tasks/ISRs in the same OS-Application.
[SWS_Os_00195]	The Operating System module may prevent write access to the private data sections of a Task/Category 2 ISR of a non-trusted application from all other Tasks/ISRs in the same OS-Application.

**Table 2.2: AUTOSAR OS Requirements - Memory Partitioning for Tasks**  
 Specification of Operating System, V5.3.0 R4.1 Rev 3

### 2.1.2.6 Implementation of Memory Partitioning

A broad variety of technical safety concepts on the system- and software level can be implemented using the mechanism Memory Partitioning.

Figure 2.8 shows a possible implementation whereas all Basic Software Modules are executed in one trusted/supervisor-mode<sup>9</sup> memory partition (highlighted in red in Figure 2.8). Some SW-Cs are logically grouped and put in separate non-trusted/user-mode memory partitions (highlighted in green). Selected SW-Cs belong to the same trusted/supervisor-mode memory partition as the Basic Software Modules (see fourth SW-C in Figure 2.8 highlighted in red). There may be several non-trusted/user-mode<sup>10</sup> partitions, each containing one or more SW-Cs.

<sup>9</sup>Supervisor Mode, Privileged Mode and Elevated Mode are synonyms for the elevated CPU mode. Trusted Mode is a mode of the Software, which is executed under the elevated CPU Mode.

<sup>10</sup>User Mode and Non-Privileged Mode are synonyms for a non-elevated CPU mode. Non-Trusted Mode is a mode of the Software, which is executed under the non-elevated CPU Mode.

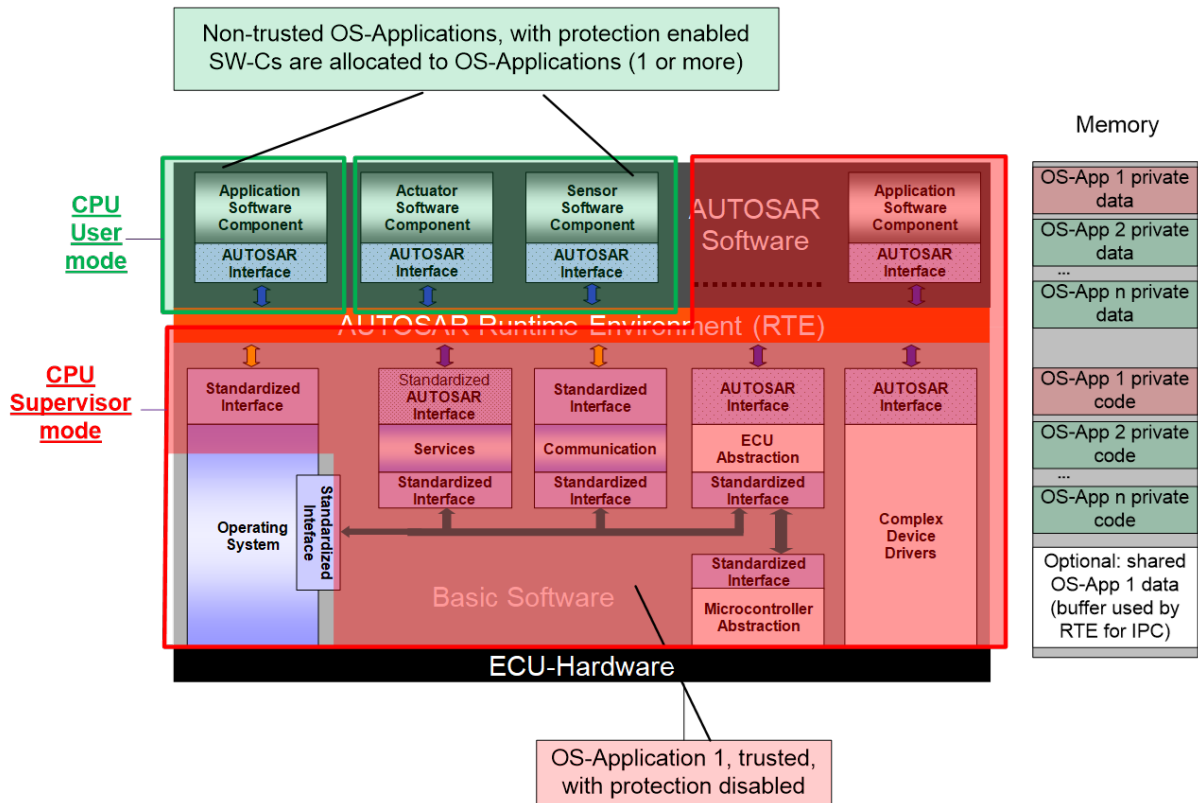

**Figure 2.8: Memory partitioning and modes**

Technical Safety Concept Status Report, V1.2.0, R4.1 Rev 1, Chapter 1.1.6 Memory Partitioning and User/Supervisor-Modes Related Features

The execution of SW-Cs in non-trusted/user-mode memory partitions is restricted from modifying other memory regions, whereas the execution of SW-Cs of trusted/supervisor-mode memory partitions is not restricted.

Modern microcontrollers for safety relevant applications support memory partitioning via dedicated hardware, a Memory Protection Unit (MPU).

Note: It is assumed that memory partitioning will be implemented on a microcontroller which has an MPU or similar hardware features<sup>11</sup>.

With a typical MPU implementation, access to multiple sections of the microcontroller address space can be allowed for non-trusted applications. Access control is defined as a combination of Read, Write and Execute accesses. The configuration of the MPU is only permissible in supervisor mode.

Note: In some microcontroller implementations the MPU is integrated within the Processor Core. Therefore that MPU only controls accesses of the associated Core. Other Bus Masters, such as DMA controllers and additional Cores, are not controlled by this particular MPU instance.

The following table and use cases illustrate a set of possible scenarios when the configuration of the memory protection unit is derived from system requirements.

<sup>11</sup>[ISO26262-6 7.4.9 b)] Partitioning

Note: This table may be incomplete with respect to the features of the specific hardware devices in use.

Address Space	Rationale	Read	Write	Execute
Flash Memory	Read, Execute and Write accesses do not modify flash memory contents. Flash memory must be erased and enabled for writing by a different mechanism first.  Note: The following implications arise from the Security point of view: Reading and execution of foreign code may be used to obtain information which is otherwise not intended for the software.	O	O	O
RAM	Write access to RAM may produce memory corruptions, thereby affecting the behavior of the software.	O	X	O
Peripheral	Side effects are possible even when reading from peripheral address space. E.g.: Acknowledgement of an Interrupt is performed via a read access to the Interrupt Controller, Read access to peripherals may cause I/O errors.	X	X	X

**Table 2.3: Configuration scenarios for Memory Protection**

Legend:

X - Protection is needed

O - Protection is optional

Note: Side effects from performance point of view may arise due to Bus Contention, arbitration at interfaces, etc.

Use Case 1: Software Components in the same Partition.

- Software Components in the same partition have access to each other's RAM regions, and therefore can corrupt each other's memory contents.
- Software components do not have access to peripheral devices by definition, as they shall be not aware of the underlying microcontroller architecture. An unsafe system can be created when a software component is given direct access to peripheral devices.

Use Case 2: Software Components in different Partitions.

- Software Components in different partitions do not have access to each other's RAM regions, and therefore cannot corrupt each other's memory contents.
- Software components do not have access to peripheral devices by definition, as they shall be not aware of the underlying microcontroller architecture. A potentially unsafe system can be created when a software component is given direct access to peripheral devices.

Use Case 3: MCAL Drivers

- MCAL Drivers are a collection of functions, such as Read/Write/Initialize. They must be executed by another entity, such as the BSW or a CDD. Please see [Figure 2.8](#) for details.



- MCAL Drivers need a Read/Write access to the peripheral space of the respective peripheral hardware module. Depending on the hardware architecture, supervisor mode of the processor may be additionally required.

### 2.1.3 Detection and Reaction

The functional safety mechanism Memory Partitioning provides protection by means of restricting access to memory and memory-mapped hardware. Code executing in one partition cannot modify memory of a different partition. Memory partitioning enables to protect read-only memory segments, as well as to protect memory-mapped hardware. Moreover, Software Components which are executed in user-mode have restricted access to CPU instructions like e.g. reconfiguration.

The mechanism Memory Partitioning can be implemented with the support of microcontroller hardware such as Memory Protection Unit or Memory Management Unit. The microcontroller hardware must be configured appropriately by the Operating System to facilitate detection and prevention of incorrect memory accesses. The execution of Software Components which are executed in non-trusted/user-mode memory partitions is then monitored.

In case of a memory access violation or a CPU instruction violation in a non-trusted/user-mode partition, the faulty access is blocked and an exception is raised by the microcontroller hardware. The OS and the RTE handle the erroneous software partition by performing either a partition shut down or restart of all SW-Cs of this partition.

Note: The actual reaction of the Operating System can be configured through the Protection Hook implementation. Please consult the OS SWS<sup>12</sup> document for further details.

Note: The AUTOSAR Document "Explanation of Error Handling on Application Level"<sup>13</sup> provides additional information on error handling. Within the document it is explained how error handling can be performed and where the required data (e.g. substitute values) can be obtained from. Furthermore the document provides a detailed explanation (user's manual) on how OS-Application/Partition termination and restart in AUTOSAR is performed.

### 2.1.4 Limitations

1. Memory Partitioning of SW-Cs with the same ASIL rating.

The ISO26262<sup>14</sup> standard requires freedom from interference between Software Components of different ASIL ratings. However, freedom from interference be-

---

<sup>12</sup>Specification of Operating System, V5.3.0 R4.1 Rev 3

<sup>13</sup>CP\_EXP\_ApplicationLevelErrorHandling[5], R4.2 Rev 1, Chapter 8, Chapter 10

<sup>14</sup>[ISO 26262-9 Clause 6]



tween Software Components of the same ASIL rating is not required by the standard.

OS-Applications which consist of a large number of Software Components are allowed. In case a single Software Component causes a violation which results in shutdown or restart of the entire memory partition, all other correctly working SW-Cs of this memory partition are affected as well.

2. Memory Partitioning is not applicable for trusted OS-Applications.

The execution of trusted/supervisor-mode memory partitions is not controlled by means of the Operating System and some MMU/MPU hardware implementations.

3. Memory Partitioning not supported on task-level.

The implementation of task-level partitioning is not mandatory for AUTOSAR OS implementations. Freedom from Interference within the OS-Application may be therefore not supported.

4. Performance penalty due to Memory Partitioning.

Depending on the architecture of the Application Software and the implementation of microcontroller hardware and the OS, there is a performance penalty associated with the use of Memory Partitioning. This penalty increases with the number of context switches which are performed per time unit.

5. No Basic Software Partitioning.

The current specification of the Basic Software does not specify memory partitioning for Basic Software Components with different ASIL ratings from different suppliers.

### 2.1.5 References to AUTOSAR Documents

Source: Requirements on AUTOSAR Features, V1.2.1, R4.1 Rev 2

AUTOSAR OS shall support isolation and protection of application software

AUTOSAR shall support usage of hardware memory protection features to enhance safety

AUTOSAR OS shall support to terminate and restart OSApplications

### 2.1.6 References to ISO26262

The following references to the ISO26262 standard are related to the aspects of freedom from interference for software components with different ASIL ratings.

Additionally, concepts related to software partitioning and memory-related faults are covered.

<i>ID</i>	<i>ISO26262 Reference</i>
01	Part 6: [7.4.9] Partitioning
02	Part 6: [7.4.11] Dependent failure analysis
03	Part 6: [D.2.1]
04	Part 6: [D.2.3]
05	Part 9: [6.2]
06	Part 9: [6.4.3]
07	Part 9: [6.4.4]

**Table 2.4: ISO26262 Memory Partitioning References**

## 2.2 Timing Monitoring

Timing is an important property of embedded systems. Safe behavior requires that the systems actions and reactions are performed within the right time.

The right time can be described in terms of a set of timing constraints that have to be satisfied. However, an AUTOSAR software component cannot ensure proper timing by itself. It depends on proper support by the AUTOSAR runtime environment and the basic software. During integration the timing constraints of the AUTOSAR software components need to be ensured.

### 2.2.1 Fault Models

According to ISO 26262<sup>15</sup>, the following Timing- and Execution-related faults can be considered as a cause for interference between software components:

- Blocking of execution
- Deadlocks
- Livelocks
- Incorrect allocation of execution time
- Incorrect synchronization between software elements

Timing protection and monitoring can be described as monitoring of the following properties: Monitoring that tasks are dispatched at the specified time, meet their execution time budgets, and do not monopolize OS resources.

To guarantee that safety-related functions will respect their timing constraints, tasks monopolizing the CPU (such as heavy CPU load, many interrupt requests) shall be detected and handled.

<sup>15</sup>[ISO 26262-6, Annex D] D.2.2 Timing and execution

## 2.2.2 Description

The following timing monitoring mechanisms are provided by AUTOSAR:

1. Timing Protection mechanisms using the Operating System.
2. Temporal Program Flow Monitoring using the Watchdog Manager.

This chapter will explain the applicability of the Watchdog Manager for implementing timing monitoring of Application Software. Temporal Program Flow Monitoring consists of the mechanisms Deadline Supervision and Alive Supervision, which will be discussed thereafter.

The Watchdog Manager also provides a mechanism called Logical Supervision, which can be combined with Deadline Supervision to provide a high diagnostic coverage. This topic is discussed in Chapter [2.3](#).

Also, an overview of the Timing Protection mechanisms of AUTOSAR OS will be given.

### 2.2.2.1 Supervised Entities

The Watchdog Manager supervises the execution of Application Software in an AUTOSAR ECU. The logical units of supervision are called Supervised Entities. There is no fixed relationship between Supervised Entities and the architectural building blocks in AUTOSAR. Typically a Supervised Entity may represent one SW-Cs or a Runnable within an SW-C, a BSW module or CDD depending on the choice of the developer.

Important places in a Supervised Entity are defined as Checkpoints. The code of Supervised Entities is interlaced with function calls of the Watchdog Manager. Those calls are used to report to the Watchdog Manager that a Checkpoint is reached.

### 2.2.2.2 Watchdog Manager

The Watchdog Manager is a basic software module of the AUTOSAR Architecture.

The Watchdog Manager links the triggering of the Watchdog Hardware<sup>16</sup> to the supervision of software execution. When a violation of the configured temporal and/or logical constraints on program execution is detected, a number of configurable actions to recover from this failure will be taken.

The Watchdog Manager provides the following mechanisms for Temporal Program Flow Monitoring:

**Alive Supervision:** Periodic Supervised Entities have constraints on the frequency with which they are executed. By means of Alive Supervision, Watchdog Manager checks periodically if the Checkpoints of a Supervised Entity have been reached within the

---

<sup>16</sup>See CP\_EXP\_LayeredSoftwareArchitecture[3], V3.4.0, R4.1 Rev 3, Page 42, Page 82.

given limits. This means that Watchdog Manager checks if a Supervised Entity is run not too frequently or not too rarely.

Alive Supervision is performed using a single Checkpoint without transitions. The supervised Entity must cyclically call the Checkpoint to signal its timely operation. The Watchdog Manager is executed periodically by the Operating System to verify the Checkpoint parameters.

A Supervised Entity can also be monitored by multiple instances of Alive Supervision, therefore containing an independent checkpoint per Alive Supervision. Please see [Figure 2.9](#).

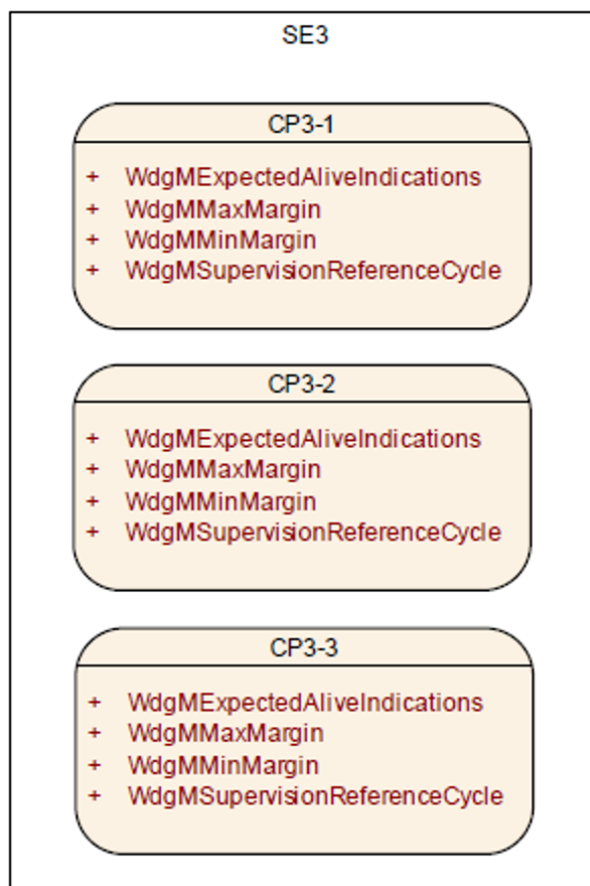
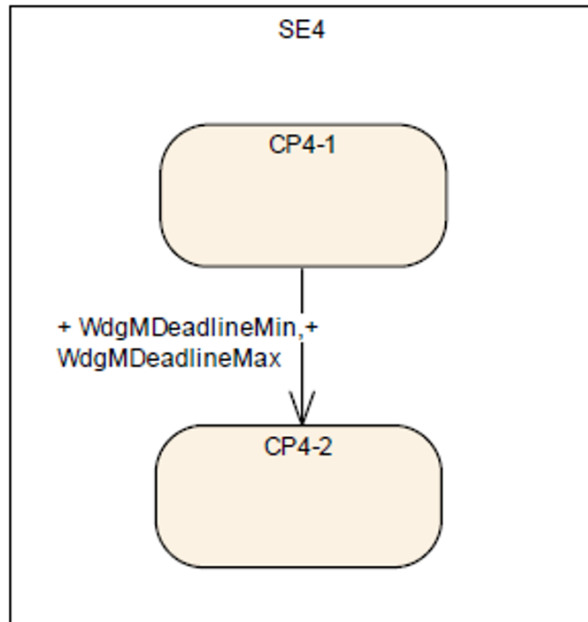

**Figure 2.9: Alive Supervision with independent Checkpoints**

CP\_SWS\_WatchdogManager[6], V2.5.0, R4.1 Rev 3, Page 43, Chapter 7.1.5 Alive Supervision Functions

Deadline Supervision: Aperiodic or episodic Supervised Entities have individual constraints on the timing between two Checkpoints. By means of Deadline Supervision, the Watchdog Manager checks the timing of transitions between two Checkpoints of a Supervised Entity. This means that the Watchdog Manager checks if some steps in a Supervised Entity take a time that is within the configured minimum and maximum. Please see [Figure 2.10](#).

If the second Checkpoint is never reached, then Deadline Supervision will fail to detect this issue. This issue appears because the timing checks are performed by the Watchdog Manager after the second Checkpoint is called.



**Figure 2.10: Deadline Supervision**

CP\_SWS\_WatchdogManager[6], V2.5.0, R4.1 Rev 3, Page 61, Chapter 7.3 Watchdog Handling

### 2.2.2.3 Timing Protection of the Operating System

According to the AUTOSAR OS Specification, a timing fault in a real-time system occurs when a task or interrupt misses its deadline at runtime.

The AUTOSAR OS does not offer deadline supervision for timing protection. Deadline supervision is insufficient to correctly identify the Task or Interrupt causing a timing fault in an AUTOSAR system. A deadline violation may be caused by unrelated Tasks or Interrupts interfering with the execution. Please consult the AUTOSAR OS Specification<sup>17</sup> for further details.

Whether a task or interrupt meets its deadline in a fixed priority preemptive operating system like AUTOSAR OS is determined by the following factors:

- The execution time of Task/Interrupt in the system.
- The blocking time that Task/Interrupt suffers from lower priority Tasks/Interrupts locking shared resources or disabling interrupts.
- The inter-arrival rate of Task/Interrupt in the system.

<sup>17</sup>Specification of Operating System, V5.3.0 R4.1 Rev 3, Chapter 7.7.2

For safe and accurate timing protection it is necessary for the operating system to control these factors at runtime to ensure that Tasks/Interrupts can meet their respective deadlines. The AUTOSAR OS provides the following timing protection mechanisms:

1. Execution Time Protection. An upper bound for execution time of Tasks or Cat2<sup>18</sup> Interrupts, the so called Execution Budget, is monitored via the OS to prevent timing errors.
2. Locking Time Protection. An upper bound for blocking of resources, locking and suspending of interrupts, the so called Lock Budget, is monitored by the OS.
3. Inter-Arrival Time Protection. A lower bound between tasks being activated or Cat 2 Interrupts arriving, a so called Time Frame, is monitored via the OS to prevent timing errors.

Note: Execution time enforcement requires hardware support, e.g. a timing enforcement interrupt. If an interrupt is used to implement the time enforcement, the priority of this interrupt shall be high enough to "interrupt" the supervised tasks or interrupts.

### 2.2.3 Detection and Reaction

The Watchdog Manager provides three mechanisms for Temporal and Logical Program Flow Monitoring: Deadline Supervision, Alive Supervision and Logical Supervision.

The supervision mechanisms are configured statically. For the monitoring of a Supervised Entity, more than one supervision mechanism can be employed.

Based on the results from each of enabled mechanisms, the status of the Supervised Entity (called Local Status) is computed. When the status of each Supervised Entity is determined, then based on each Local Supervision Status, the status of the whole MCU is determined (called Global Supervision Status).

Depending on the Local Supervision Status of each Supervised Entity and on the Global Supervision Status, the Watchdog Manager initiates a number of mechanisms to recover from supervision failures. These range from local error recovery within the Supervised Entity to a global reset of the ECU.

The following error recovery mechanisms can be employed by the Watchdog Manager:

1. Error Handling in the Supervised Entity

In case the Supervised Entity is an SW-C or a CDD, then the Watchdog Manager may inform the Supervised Entity about supervision failures via the RTE Mode mechanism. The Supervised Entity may then take its actions to recover from that failure.

---

<sup>18</sup>Category 2 Interrupts are managed by the Operating System. Category 1 Interrupts are executed outside of the Operating System and therefore cannot be monitored.

The Watchdog Manager may register an entry with the Diagnostic Event Manager (DEM) when it detects a supervision failure. A Supervised Entity may take recovery actions based on that error entry.

## 2. Partition Shutdown

If the Watchdog Manager module detects a supervision failure in a Supervised Entity which is located in a non-trusted partition, the Watchdog Manager module may request a partition shutdown by calling the BswM.

## 3. Reset by Hardware Watchdog

The Watchdog Manager indicates to the Watchdog Interface when Watchdog Interface shall no longer trigger the hardware watchdog. After the timeout of the hardware watchdog, the hardware watchdog resets the ECU or the MCU. This leads to a re-initialization of the ECU and/or MCU hardware and the complete re-initialization of software.

## 4. Immediate MCU Reset

In case an immediate, global reaction to the supervision failure is necessary, the Watchdog Manager may directly cause an MCU reset. This will lead to a re-initialization of the MCU hardware and the complete software. Usually, a MCU reset will not re-initialize the rest of the ECU hardware.

Note: The AUTOSAR Document "Explanation of Error Handling on Application Level"<sup>19</sup> provides additional information on error handling. Within the document it is explained how error handling can be performed and where the required data (e.g. substitute values) can be obtained from. Furthermore the document provides a detailed explanation (user's manual) on how OS-Application/Partition termination and restart in AUTOSAR is performed.

### 2.2.4 Limitations

1. The granularity of Checkpoints is not fixed by the Watchdog Manager. Few coarse-grained Checkpoints limit the detection abilities of the Watchdog Manager. For example, if an application SW-C only has one Checkpoint that indicates that a cyclic Runnable has been started, then the Watchdog Manager is only capable of detecting that this Runnable is re-started and check the timing constraints. In contrast, if that SW-C has Checkpoints at each block and branch in the Runnable the Watchdog Manager may also detect failures in the control flow of that SW-C. High granularity of Checkpoints causes a complex and large configuration of the Watchdog Manager.
2. The Deadline Supervision has a weakness: it only detects the delays (when the End Checkpoint is reported), but it does not detect the timeouts (when the End Checkpoint is not reported at all).

---

<sup>19</sup>CP\_EXP\_ApplicationLevelErrorHandling[5], R4.2 Rev 1, Chapter 8, Chapter 10



3. The nesting of Deadline Supervision (i.e. start 1, start 2, end 2, end 1) is not supported.
4. The Alive Supervision function with more than one checkpoint per Supervised Entity is not consistently specified within the Specification of Watchdog Manager document. For now it is recommended to support only one alive supervision checkpoint per Supervision Entity.
5. In order to shutdown or restart (as error reaction) a partition containing Supervised Entities, the integrator code (OS Application's restart task) must deactivate (or deactivate + activate) all Supervised Entities of the involved partition, by calling available functions of Watchdog Manager. This is a bit complex, in future releases of the Specification of Watchdog Manager document it is considered to add a new function of Watchdog Manager for this.
6. Libraries cannot call BSWs, so libraries cannot be supervised by Watchdog Manager. Deadline Supervision could be used however by placing checkpoints before and after a library call in the module's code to supervise libraries.
7. It is not standardized how BSW modules are identified with Supervised Entity IDs.

### 2.2.5 References to AUTOSAR Documents

Source: Requirements on AUTOSAR Features, V1.2.1, R4.1 Rev 2

AUTOSAR shall support program flow monitoring

AUTOSAR OS shall support timing protection

AUTOSAR OS shall support timing protection

### 2.2.6 References to ISO26262

The following references to the ISO26262 standard are related to the aspects of freedom from interference for software components with different ASIL ratings. Concepts related to timing supervision are covered.

<i>ID</i>	<i>ISO26262 Reference</i>
03	Part 6: [D.2.1]
08	Part 6: [D.2.2]
09	Part 6: [7.4.12] NOTE 2, Monitoring of program execution by an external element

**Table 2.5: ISO26262 Timing Monitoring References**



## 2.3 Logical Supervision

Logical Supervision is a technique for checking the correct execution of software and focuses on control flow errors.

Control flow errors cause a divergence from the valid (i.e. coded/compiled) program sequence during the error-free execution of the application. An incorrect control flow occurs if one or more program instructions are processed either in the incorrect sequence or are not even processed at all. Control flow errors can for example lead to data inconsistencies, data corruption, or other software failures.

### 2.3.1 Fault Models

According to ISO 26262<sup>20</sup>, the following Timing- and Execution-related faults can be considered as a cause for interference between software components:

- Blocking of execution
- Deadlocks
- Livelocks
- Incorrect allocation of execution time
- Incorrect synchronization between software elements

Logical and temporal monitoring of program sequences is used in the automotive industry and mentioned e.g. in ISO 26262 as a measure to detect failures of the processing units (i.e. CPU, microcontroller) and as measure for the detection of failures of the HW clock.

Faults in execution of program sequences (i.e. invalid execution of program sequences) can lead to data corruption, process crashes, or fail-silence violations.

Logical monitoring of program sequences is required/recommended/proposed by ISO 26262, IEC 61508, MISRA.

### 2.3.2 Description

Logical Supervision of the execution sequence of a program enables the detection of errors that cause a divergence from the valid program sequence during the error-free execution of the application. An incorrect program flow occurs if one or more program instructions are processed either in an incorrect sequence or not even processed at all.

The Watchdog Manager supervises the execution of Application Software in an AUTOSAR ECU. The logical units of supervision are called Supervised Entities. There is

---

<sup>20</sup>[ISO 26262-6, Annex D] D.2.2 Timing and execution

no fixed relationship between Supervised Entities and the architectural building blocks in AUTOSAR. Typically a Supervised Entity may represent one SW-Cs or a Runnable within an SW-C, a BSW module or CDD depending on the choice of the developer.

Places relevant for logical supervision in a Supervised Entity are defined as Checkpoints. The code of Supervised Entities is interlaced with function calls of the Watchdog Manager. Those calls are used to report to the Watchdog Manager that a Checkpoint is reached.

Each Supervised Entity has one or more Checkpoints. The Checkpoints and Transitions between the Checkpoints of a Supervised Entity form a Graph.

A Graph may have one or more<sup>21</sup> initial Checkpoints and one or more final Checkpoints. Any sequence of starting with any initial checkpoint and finishing with any final checkpoint is correct, assuming that the checkpoints belong to the same Graph.

A graph within a Supervised Entity is called an Internal Graph. Checkpoints from different Supervised Entities can be connected by External Transitions, forming an External Graph.

Figure 2.11 shows a Graph representation of a While-Loop, which consists of Checkpoints and Transitions.

---

<sup>21</sup>Internal graphs can have only one initial Checkpoint. External graphs can have multiple initial Checkpoints.

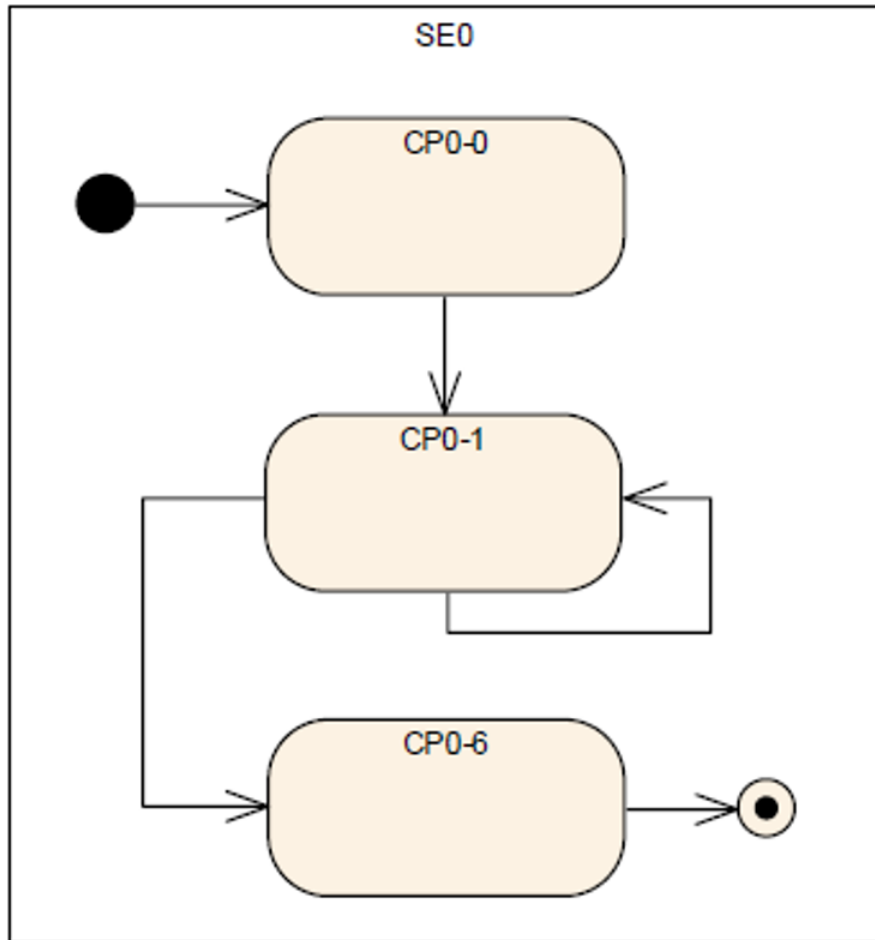

**Figure 2.11: Abstract Control Flow Graph of a While-Loop**

CP\_SWS\_WatchdogManager[6], V2.5.0, R4.1 Rev 3, Chapter 7.1.7 Logical Supervision

At runtime, the Watchdog Manager verifies if the supervised Entities are executed according to the configured Graphs. This is called Logical Supervision.

Also, the Watchdog Manager can verify the timing of Checkpoints and Transitions within a Graph.

The timing of Transitions between Checkpoints can be verified via Deadline Supervision, whereas Logical Monitoring verifies the correct order of the Checkpoints. The details of Timing Monitoring mechanisms are described in Chapter 2.2.

**2.3.3 Detection and Reaction**

During design phase the valid program sequences are identified and modeled. During runtime the Watchdog Manager uses this model to supervise or monitor the proper execution of program sequences.

The Watchdog Manager provides three mechanisms for Temporal and Logical Program Flow Monitoring: Deadline Supervision, Alive Supervision and Logical Supervision.

The supervision mechanisms are configured statically. For the monitoring of a Supervised Entity, more than one supervision mechanism can be employed.

Based on the results from each of enabled mechanisms, the status of the Supervised Entity (called Local Status) is computed. When the status of each Supervised Entity is determined, then based on each Local Supervision Status, the status of the whole MCU is determined (called Global Supervision Status).

Depending on the Local Supervision Status of each Supervised Entity and on the Global Supervision Status, the Watchdog Manager initiates a number of mechanisms to recover from supervision failures. These range from local error recovery within the Supervised Entity to a global reset of the ECU.

The following error recovery mechanisms can be employed:

1. Error Handling in the Supervised Entity:

In case the Supervised Entity is an SW-C or a CDD, then the Watchdog Manager may inform the Supervised Entity about supervision failures via the RTE Mode mechanism. The Supervised Entity may then take its actions to recover from that failure.

The Watchdog Manager may register an entry with the Diagnostic Event Manager (DEM) when it detects a supervision failure. A Supervised Entity may take recovery actions based on that error entry.

2. Partition Shutdown

If the Watchdog Manager module detects a supervision failure in a Supervised Entity which is located in a non-trusted partition, the Watchdog Manager module may request a partition shutdown by calling the BswM.

3. Reset by Hardware Watchdog

The Watchdog Manager indicates to the Watchdog Interface when Watchdog Interface shall no longer trigger the hardware watchdog. After the timeout of the hardware watchdog, the hardware watchdog resets the ECU or the MCU. This leads to a re-initialization of the ECU and/or MCU hardware and the complete re-initialization of software.

4. Immediate MCU Reset

In case an immediate, global reaction to the supervision failure is necessary, the Watchdog Manager may directly cause an MCU reset. This will lead to a re-initialization of the MCU hardware and the complete software.

Note: The AUTOSAR Document "Explanation of Error Handling on Application Level"<sup>22</sup> provides additional information on error handling. Within the document it is explained how error handling can be performed and where the required data (e.g. substitute values) can be obtained from. Furthermore the document provides a detailed explanation

---

<sup>22</sup>CP\_EXP\_ApplicationLevelErrorHandling[5], R4.2 Rev 1, Chapter 8, Chapter 10

(user's manual) on how OS-Application/Partition termination and restart in AUTOSAR is performed.

### 2.3.4 Limitations

1. For Logical Supervision, Watchdog manager does not support any overlapping graphs - a checkpoint shall belong to maximum one Graph. This is required to be able to allocate a received Checkpoint notification to a Graph.
2. Watchdog Manager does not support Logical Supervision of concurrently executed Supervised Entities, because it follows only one instance of a Graph at a time.
3. In order to shutdown or restart (as error reaction) a partition containing Supervised Entities, the integrator code (OS Application's restart task) must deactivate (or deactivate + activate) all Supervised Entities of the involved partition, by calling available functions of Watchdog Manager.

### 2.3.5 References to AUTOSAR Documents

Source: Requirements on AUTOSAR Features, V1.2.1, R4.1 Rev 2

AUTOSAR shall support program flow monitoring

### 2.3.6 References to ISO26262

The following references to the ISO26262 standard are related to the aspects of freedom from interference for software components with different ASIL ratings. Concepts related to logical supervision are covered.

<i>ID</i>	<i>ISO26262 Reference</i>
03	Part 6: [D.2.1]
08	Part 6: [D.2.2]
09	Part 6: [7.4.12] NOTE 2, Monitoring of program execution by an external element and Temporal monitoring of program execution

**Table 2.6: ISO26262 Logical Supervision References**

## 2.4 End-2-End Protection

In a distributed system, the exchange of data between a sender and the receiver(s) can affect functional safety, if its safe behavior safety depends on the integrity of such data (see "Exchange of Information" fault example in the beginning of this chapter).

Therefore, such data shall be transmitted using mechanisms to protect it against the effects of faults within the communication link.

### 2.4.1 Fault Models

According to ISO 26262<sup>23</sup>, the following Exchange of Information-related faults can be considered for each sender or each receiver software component executed in different software partitions or ECUs:

- Repetition of information;
- Loss of information;
- Delay of information;
- Insertion of information;
- Masquerade or incorrect addressing of information;
- Incorrect sequence of information;
- Corruption of information;
- Asymmetric information sent from a sender to multiple receivers;
- Information from a sender received by only a subset of the receivers;
- Blocking access to a communication channel.

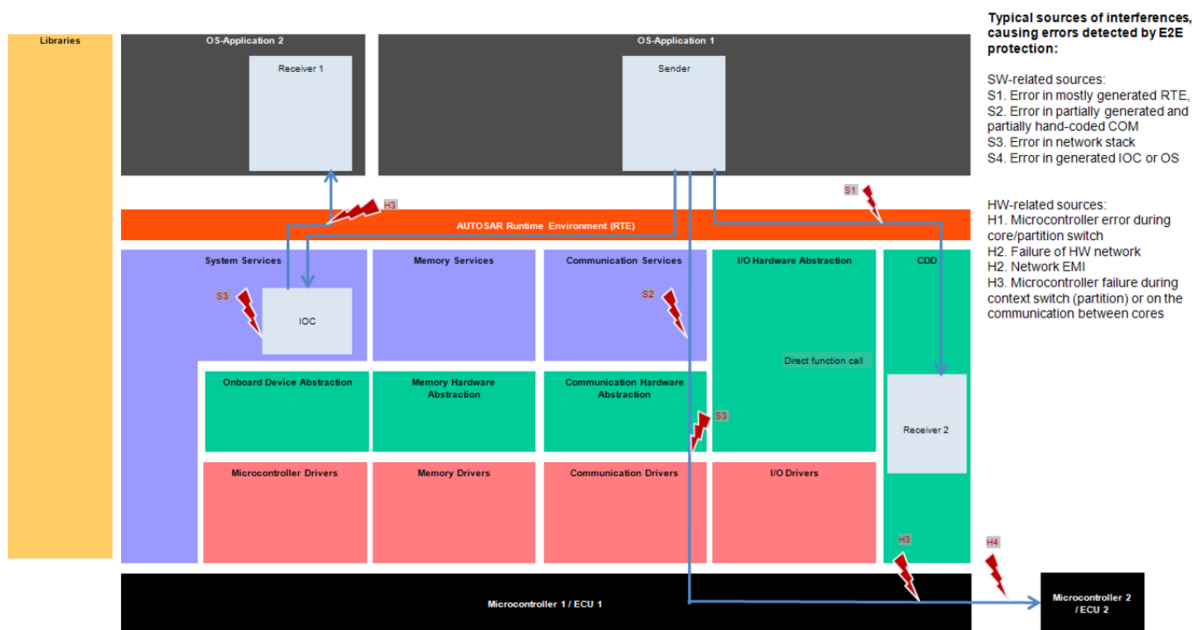

**Figure 2.12: End-2-End Protection**  
 CP\_SWS\_E2ELibrary[7], V3.2.1, R4.1 Rev 3

<sup>23</sup> [ISO 26262-6, Annex D] D.2.4 Exchange of Information

The concept of End-2-End protection assumes that safety-related data exchange shall be protected at runtime against the effects of faults within the communication link (see [Figure 2.12](#)). Examples for such faults are random HW faults (e.g. corrupt registers of a CAN transceiver), interference (e.g. due to EMC), systematic faults within the software implementing the VFB communication (e.g. RTE, IOC, COM and network stacks) inside the ECU and outside, such as on Gateways.

The following faults related to message exchange via communication network have been considered in the End-2-End Library.

Fault Model	Description
Repetition of information	A type of communication fault, where information is received more than once.
Loss of information	A type of communication fault, where information or parts of information are removed from a stream of transmitted information.
Delay of information	A type of communication fault, where information is received later than expected.
Insertion of information	A type of communication fault, where additional information is inserted into a stream of transmitted information.
Masquerading	A type of communication fault, where non-authentic information is accepted as authentic information by a receiver.
Incorrect addressing	A type of communication fault, where information is accepted from an incorrect sender or by an incorrect receiver.
Incorrect sequence of information	A type of communication fault, which modifies the sequence of the information in a stream of transmitted information.
Corruption of information	A type of communication fault, which changes information.
Asymmetric information sent from a sender to multiple receivers	A type of communication fault, where receivers do receive different information from the same sender.
Information from a sender received by only a subset of the receivers	A type of communication fault, where some receivers do not receive the information
Blocking access to a communication channel	A type of communication fault, where the access to a communication channel is blocked.

**Table 2.7: Fault Models of a Communication Network**  
 CP\_SWS\_E2ELibrary[7], V3.2.1, R4.1 Rev 3, Chapter 4.3.3

## 2.4.2 Description

From the perspective of Software Components, data transmission via the RTE behaves like a simple point-to-point connection. However, the implementation of this abstraction requires a highly complex infrastructure made up of software layers, communication stacks, drivers and the underlying hardware. Along with the complexity, the number of potential sources for failures also increases.

The use of the End-2-End protection mechanism assumes that the integrity of safety-relevant data has to be maintained during communication, protecting the data against the effects of faults within the communication link.

The most important aspects of the End-2-End protection are the standardization of the protection capabilities and the flexible applicability of the mechanism. Mechanisms for safe data communication within and between ECUs through the concept of End-2-End protection will be described in this chapter.

The architecture of the End-2-End protection is implemented as follows: Data Elements consisting of Application Data are extended on the sender side with additional control information, the End-2-End header. The control information usually contains a Checksum, a Counter and other options. The extended data element is provided to the RTE for transmission, as shown in [Figure 2.13](#). It shows the principle of E2E, but not all details required for implementation. Especially the usage of the RTE Data Transformer to encode/decode complex data elements is omitted for simplicity.

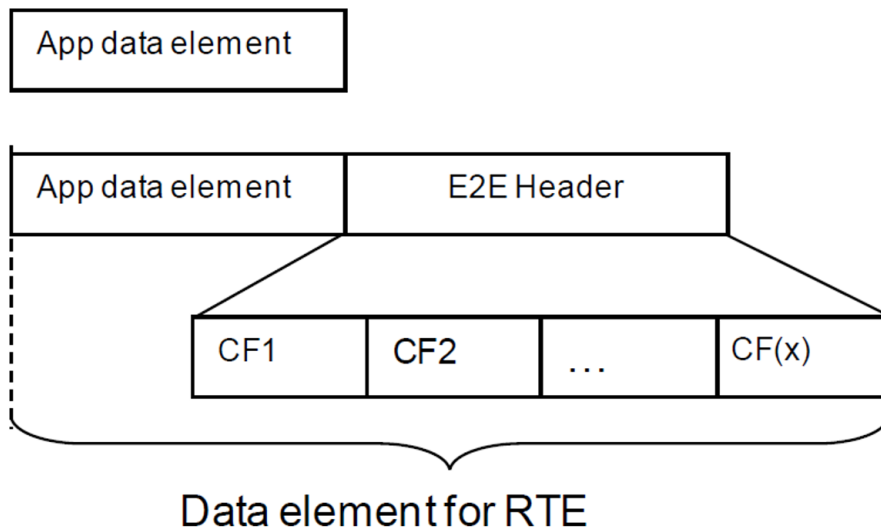

**Figure 2.13: Data Element for RTE**

CP\_SWS\_E2ELibrary[7], V3.2.1, R4.1 Rev 3, Chapter 8.1

Data Elements are verified at the receiver side by processing the contents of the End-2-End header against the Application Data. After the received data element is processed and accepted as correct, the control information is removed and Application Data is provided to the target Software Component.

The error handling is performed at the receiver.

### 2.4.2.1 End-2-End Profiles

AUTOSAR specifies a set of standardized and configurable End-2-End profiles, which implement a set of protection mechanisms and specify the data format for the attached End-2-End header.

An End-2-End Profile uses a subset of the following data protection mechanisms:<sup>24</sup>

<sup>24</sup>CP\_SWS\_E2ELibrary[7], V3.2.1, R4.1 Rev 3, SWS\_E2E\_00221



1. CRC Checksum, provided by the CRC library;
2. Sequence Counter incremented at every transmission request, the value is checked at receiver side for correct incrementation;
3. Alive Counter incremented at every transmission request, the value checked at the receiver side if it changes at all, but correct incrementation is not checked
4. A specific ID for every port data element sent over a port (global to system, where the system may contain potentially several ECUs).
5. Timeout detection: Receiver communication timeout and Sender acknowledgement timeout

Three End-2-End Profiles are specified in the AUTOSAR Standard, Profile 1 with two variants, End-2-End Profile 2 and End-2-End Profile 4. Upcoming releases will also specify Profiles 5 and 6.

Only the standardized End-2-End profiles shall be used, non-standard End-2-End Profile configurations may only be used in special cases, such as for legacy software.

The protection mechanisms of the End-2-End Profile 1 are described in Table 8 as follows:

Mechanism	Description	Fault Model
Counter	A 4Bit Counter is incremented with every Send-Request. This Value is explicitly sent.	Repetition, deletion, insertion, incorrect sequence
Timeout	Using a non-blocking read, the receiver can determine if the value of the counter has been increased.	Deletion, delay
Data ID	Each sender-receiver port has a unique 16-Bit ID, which is used in the CRC calculation. The CRC calculation is illustrated in <a href="#">Figure 2.14</a> .  The Data ID value is not explicitly sent. As the ID is only known at the sender and the receiver, the CRC calculation can only be correctly performed by the corresponding partners.	Insertion, addressing faults
CRC	A CRC Checksum (8-Bit) calculation is performed over all data elements, the Counter and the Data ID. This value is explicitly sent.	Corruption

**Table 2.8: Mechanisms in End-2-End Profile 1**

[Figure 2.14](#) illustrates how the CRC calculation is performed in the End-2-End Profile 1. The value of Data ID is calculated into the CRC value, so both communication partners must use the same Data ID to correctly verify the CRC Checksum of a message.

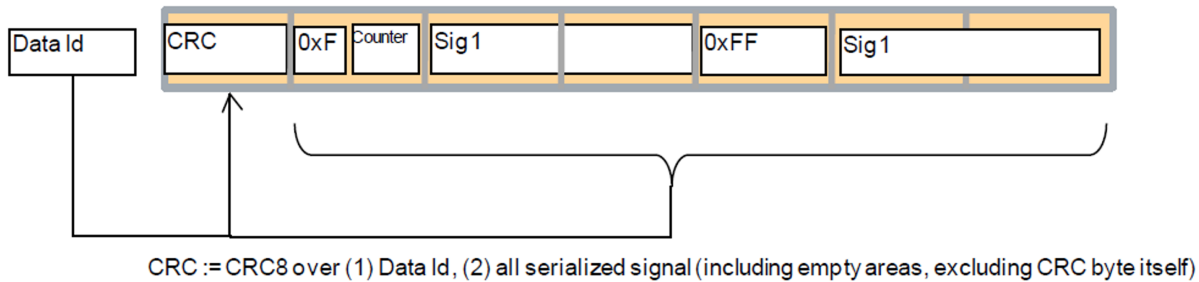

**Figure 2.14: CRC Calculation in End-2-End Profile 1**

CP\_SWS\_E2ELibrary[7], V3.2.1, R4.1 Rev 3, Chapter 8.3.4

Although the length of the Data ID is 16 bits, leading to a large number of individual Data IDs, the length of the CRC checksum is only 8 bits. This means that different Data IDs will produce the same CRC checksum, thus limiting the number of independent Data IDs.

If a message is routed to the wrong destination, e.g. due to Bit-flips in a gateway, and the Data IDs produce the same CRC checksum, then the receiver would accept the misdirected message, assuming that the current counter value and the length of the message are both correct. The extent of the underlying protection against Addressing Faults is diminished. This fault model is called Masquerading.

It is possible to restrict the Data ID values so there is no overlap in the CRC Checksums. This however limits the number of independent Data IDs to 255.

The End-2-End Profile 2 takes a different approach in the use of the Data ID protection mechanisms. Each sender-receiver port pair has a list of Data IDs. The current value of the sequence counter determines which Data ID is used.

An appropriate selection of Data IDs is required to increase the number of messages for which detection of masquerading is possible. However, there will be overlaps of the 8-Bit Data ID and Counter values, limiting the number of independent Data IDs and Counter values to 256.

If a single erroneously received message does not violate the safety goal of the system, then the End-2-End Profile 2 allows for protection against masquerading for a greater number of messages.

Mechanism	Description	Fault Model
Sequence Number (Counter)	A 4Bit Counter is incremented with every Send-Request. This Value is explicitly sent.	Unintended message repetition, message loss, insertion of messages, re-sequencing





Message Key used for CRC calculation (Data ID)	8 bit (not explicitly sent) The Data ID used for CRC calculation is an element of a pre-defined list and depends on the current value of the Counter. The list of Data IDs is unique for each Data Element and only known to the sender and the receiver.	Insertion of messages, masquerading
Safety Code (CRC)	A CRC Checksum (8-Bit) calculation is performed over all data elements, the Counter and the Data ID. This value is explicitly sent.	Message corruption, insertion of messages (masquerading)
Timeout (detection and handling implemented by SW-C)	Timeout detection must be implemented by the SW-C.	Message loss, message delay

**Table 2.9: Mechanisms in End-2-End Profile 2**

AUTOSAR supports PDUs up to 4kB in size, either through the TCP/IP stack or through TP services of FlexRay TP, CAN TP, etc. The End-2-End Profiles 1 and 2 support an ASIL-D compliant transmission of up to 30 or 42 byte PDUs, due to the short 8-Bit CRC checksum.

The AUTOSAR Release 4.2.1 introduces a new End-2-End Profile. The End-2-End Profile 4 is specifically designed for ASIL-D compliant transmission of long data. This is supported by the use of a special 32-Bit CRC polynomial. This polynomial is superior to the widely used IEEE 802.3 CRC, as it provides a higher Hamming Distance for long data.

Mechanism	Description	Fault Model
Counter	A 16 Bit Counter is incremented with every Send-Request. This Value is explicitly sent.	Unintended message repetition, message loss, insertion of messages, re-sequencing
CRC	The 32 Bit CRC is calculated over the entire E2E header (excluding the CRC bytes) and over the user data. This Value is explicitly sent. Note: This CRC polynomial is different from the CRC-polynomials used by FlexRay, CAN, LIN and TCP/IP.	Message corruption, insertion of messages (masquerading)
Data ID	The 32 Bit Data ID shall be unique for a specific data element within the network of ECUs. This Value is explicitly sent.	Insertion of messages, masquerading
Timeout (detection and handling implemented by SW-C)	The receiver reads the currently available data, i.e. checks if new data is available. Then, by means of the counter, the receiver can detect loss of communication and timeouts.	Message loss, message delay

**Table 2.10: Mechanisms in End-2-End Profile 4**

The End-2-End Profile 4 header provides the following control fields, which are transmitted together with the protected data.

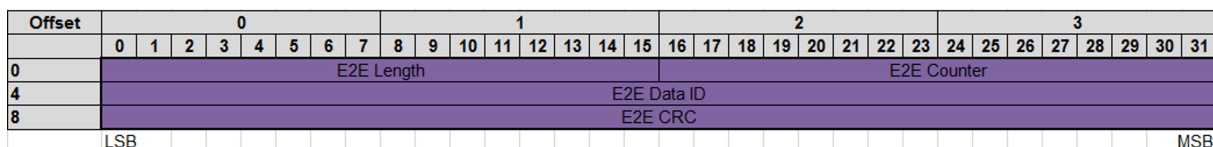

**Figure 2.15: End-2-End Profile 4 header**

Contrary to E2E Profiles 1 and 2, there is an explicit transmission of the data length, as data packets do not have a standard size. The 16 bits Length field is introduced to support variable-size data, which can have a different length in each transmission cycle. Also there is an explicit transmission of the Data ID.

#### **2.4.2.2 End-2-End State Machine**

Data Elements are verified at the receiver side by processing the contents of the End-2-End header against the Application Data using the End-2-End Profile's check-function. It determines whether the received data of this cycle is correct and provides additional information in case of detected faults.

The AUTOSAR Release 4.2.1 introduces a State Machine, which helps to determine whether the received Application Data is acceptable with a greater level of detail. A new level of abstraction is introduced, so applications receive an overall status of the communication, instead of dealing with the status of every single message.

The new state machine supports configurable settings for the number of lost or repeated packets, recoverable and non-recoverable communication faults, as well as initialization of communication. [Figure 2.15](#) illustrates the design and features of the state machine.

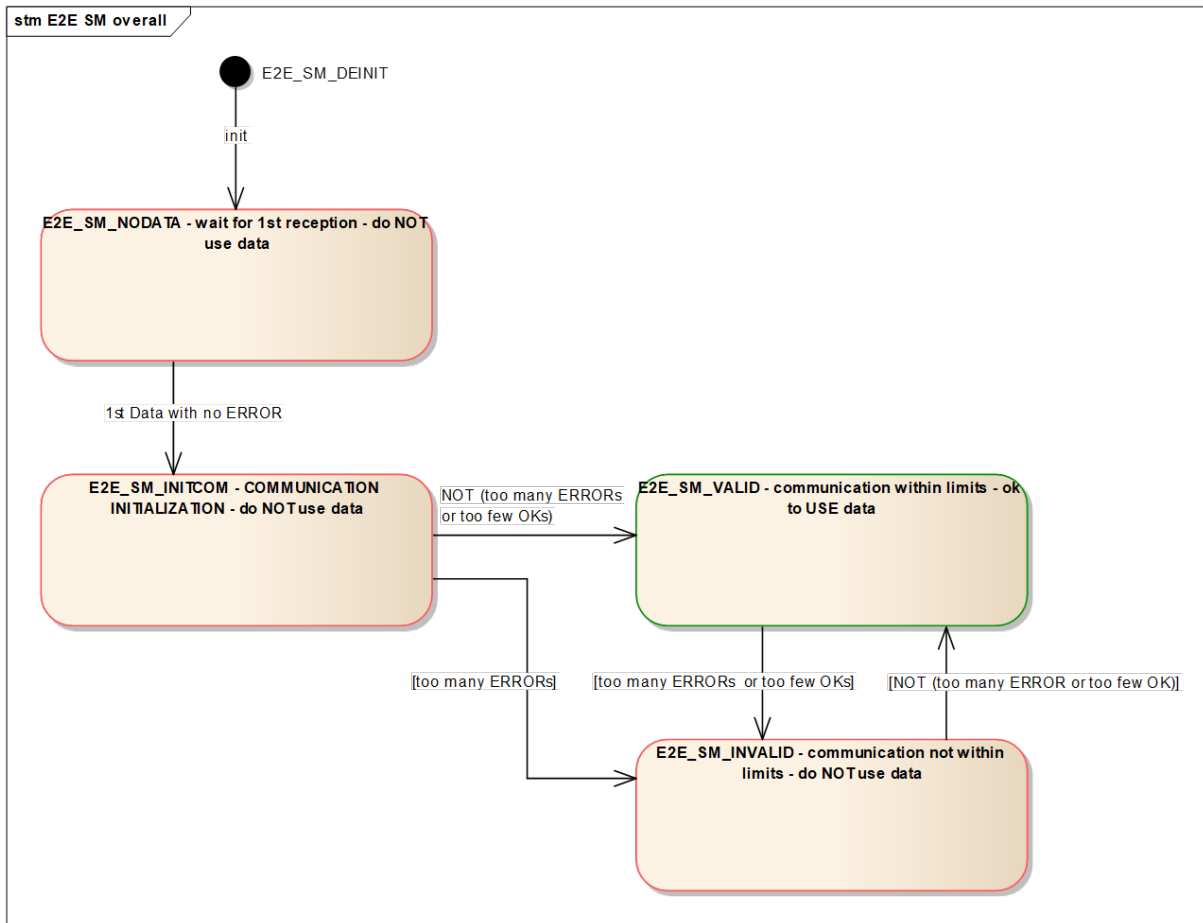

**Figure 2.16: End-2-End State Machine**

CP\_SWS\_E2ELibrary[7], V3.0.0-0.10.4, R4.1 Rev 3, Chapter 7.8.1

### 2.4.2.3 Integration of the End-2-End Protection Library

To enable the proper usage of the End-2-End Library, different solutions are possible. They may depend on the integrity of RTE, COM or other basic software modules as well as the usage of other SW/HW mechanisms (e.g. memory partitioning).

The End-2-End Library can be used to protect safety-related data elements exchanged between SW-Cs by means of End-2-End Protection Wrapper.

Furthermore, the End-2-End Library can be used to protect safety-related I-PDUs by means of COM Callouts.

It is also possible to have mixed scenarios, where some data elements are protected at the SW-C level (e.g. with End-2-End protection Wrapper) and some with COM End-2-End callouts.

Introduced in AUTOSAR Release 4.2.1, the RTE Data Transformer can also be used to protect data exchange of complex data elements between ECUs at the RTE level.

#### 2.4.2.4 End-2-End Protection Wrapper

The End-2-End Protection Library can be used to protect the data communication between SW-Cs at the RTE level. To accomplish this, the End-2-End Protection Wrapper functions as a wrapper over the `Rte_Write` and `Rte_Read` functions, which are offered to SW-Cs. The End-2-End Protection Wrapper encapsulates the `Rte_Read/Write` invocations of the Software Component and protects the data exchange using the End-2-End Library.

In this approach, every safety-related SW-C has its own additional sub-layer (a .h/.c file pair) called the End-2-End Protection Wrapper, which is responsible for marshalling of complex data elements into the layout identical to the corresponding I-PDUs (for inter-ECU communication), and for correct invocation of End-2-End Library and of RTE. Please see [Figure 2.17](#).

The usage of the End-2-End Protection Wrapper allows a use of VFB communication between SW-Cs, without the need of further measures to ensure VFB's integrity.

The communication between such SW-Cs can be within an ECU (which means on the same or different cores or within the same or different memory partitions of a microcontroller) or across ECUs (SW-Cs connected by a VFB also using a network).

The end-to-end protection is a systematic solution for protecting SW-C communication, regardless of the communication resources used (e.g. COM and network, OS/IOC or internal communication within the RTE). Relocation of SW-Cs may only require selection of other protection parameters, but no changes on SW-C application code.

Also, the use of the End-2-End protection wrapper supports safe communication between software components despite a potentially unsafe communication software stack.

Note: The End-2-End Protection Wrapper does not support multiple instantiation of the SW-Cs. This means, if an SW-C is supposed to use End-2-End Protection Wrapper, then this SW-C must be single-instantiated. This limitation is based on the fact that multiple instances of a Software Component would have the same `DataID`, thus limiting the capabilities of the underlying protection mechanisms.

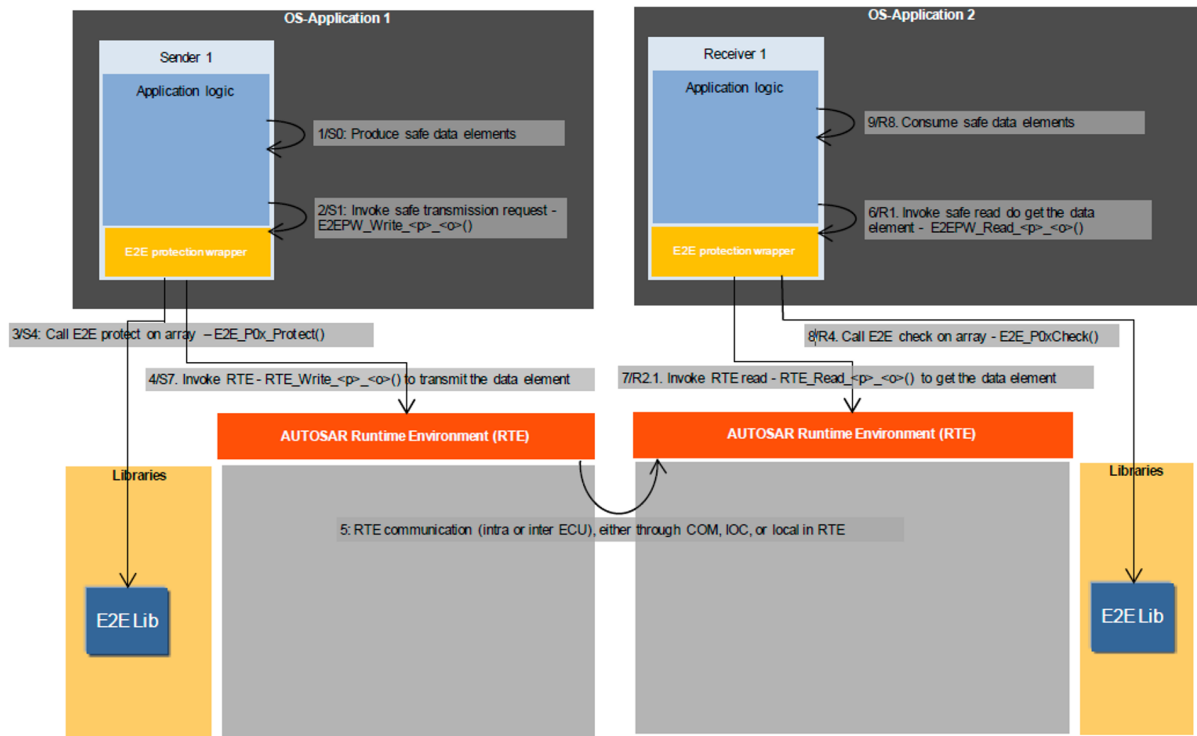

**Figure 2.17: End-2-End Protection Wrapper - Communication Overview**

CP\_SWS\_E2ELibrary[7], V3.2.1, R4.1 Rev 3, Chapter 13.1.1

### 2.4.2.5 Transmission Manager

In an ECU system where integrity of operation is not provided for COM and RTE, it is possible to transmit safety-related data through the network.

On the sender ECU, there is a dedicated SW-C called the Transmission Manager, containing End-2-End Protection Wrapper. The Transmission Manager collects safety-related data from related SW-Cs, combines them and protects them using the End-2-End Protection Wrapper. Finally, it provides the combined and protected Data as a Data Element to the RTE. Please see [Figure 2.18](#).

On the receiver ECU a Transmission Manager does the reverse steps for the reception of such data.

The Transmission Manager replaces the duties of the RTE and COM, such as merging of Data Elements into PDUs and ensuring the integrity of data.

Note: The Transmission Manager SW-C module is neither part of End-2-End Library nor part of AUTOSAR. Also, the integrity of RTE communication between the SW-Cs and the Transmission Manager shall be protected by other measures.

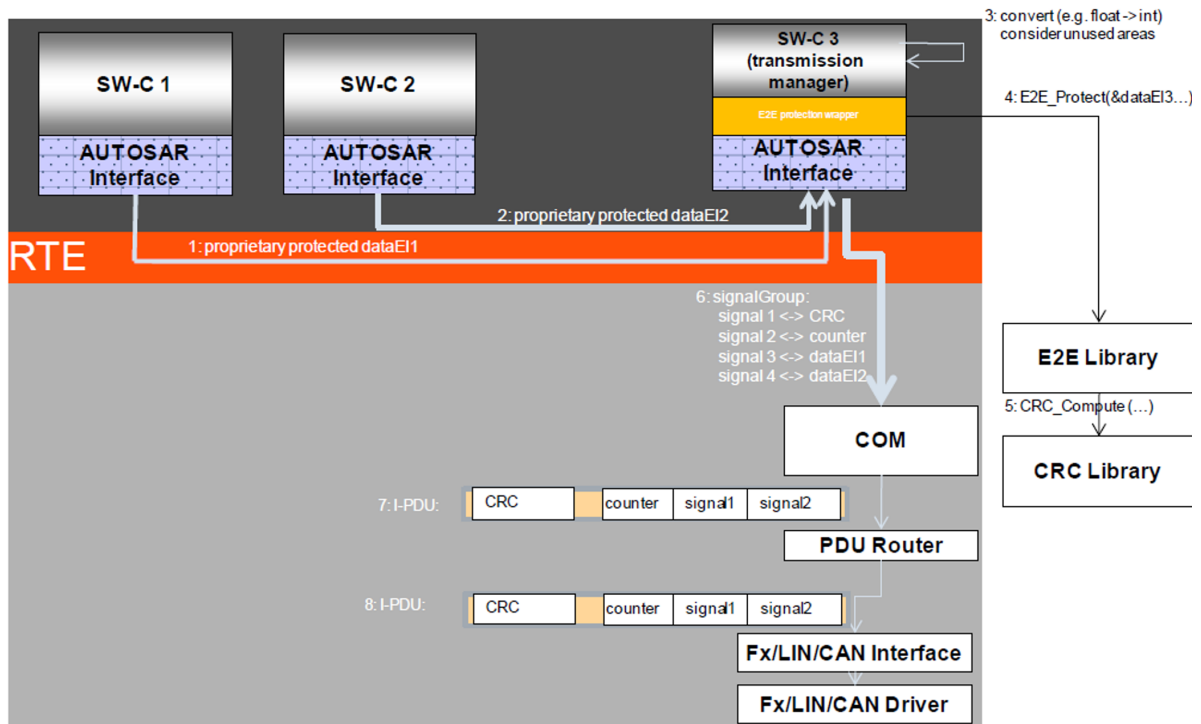

**Figure 2.18: Transmission Manager - Sender ECU**

CP\_SWS\_E2ELibrary[7], V3.2.1, R4.1 Rev 3, Chapter 13.1.2

### 2.4.2.6 COM End-2-End Callout

In this approach, the End-2-End Library is used to protect the data exchange between COM modules. The End-2-End Library is invoked by COM, through COM End-2-End callouts, to protect and check the I-PDUs. The callout invokes the End-2-End Library with parameters appropriate for a given I-PDU. Please see [Figure 2.19](#).

For each I-PDU to be protected and checked there is a separate callout function. Each callout function "knows" how each I-PDU needs to be protected and checked. This means that the callout invokes the End-2-End Library functions with settings and state parameters that are appropriate for the given I-PDU.

This solution works with all communication models, multiplicities offered by RTE for inter-ECU communication. In contrast to the Transmission Manager, this solution can only be used in systems where the integrity of operation of COM and RTE is provided.



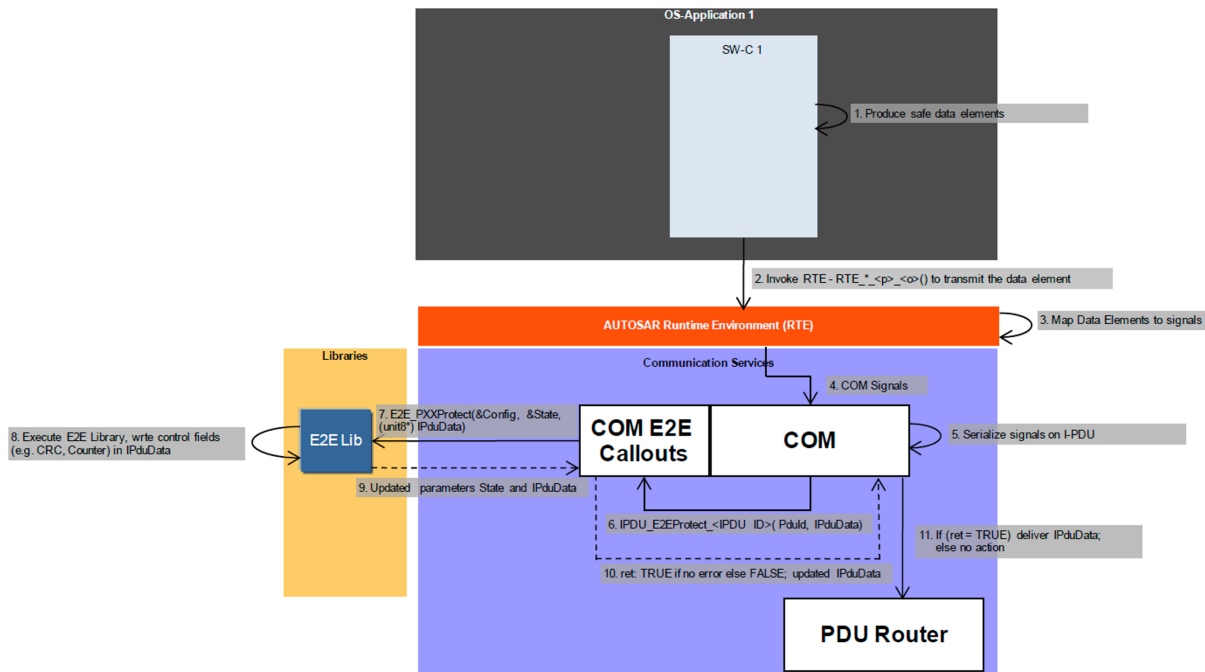

**Figure 2.19: COM Callout - Overview**

CP\_SWS\_E2ELibrary[7], V3.2.1, R4.1 Rev 3, Chapter 13.2.1

### 2.4.2.7 RTE Data Transformer

Introduced in AUTOSAR Release 4.2.1, the RTE Data Transformer can be used to protect the exchange of complex data elements between ECUs.

The main difference between the previously described mechanisms for End-2-End Library invocation can be illustrated as follows:

The End-2-End protection wrapper extends the complex data element<sup>25</sup> under protection by adding data elements of the End-2-End header. The additional data elements can be seen by the SW-C but are ignored. The RTE Protection Wrapper, therefore, does not support the protection of individual signals, unless they are embedded within a complex data element.

COM maps the individual signals of a complex data element into PDUs. Using COM Callouts, the contents of the entire PDU are protected. The maximum PDU size is however limited by the physical properties of the interconnection bus.

Complex data elements can be prepared for transmission by being specifically arranged in a Byte-Array by a process called serialization. The serialized data array can be then protected using the End-2-End Library as a single piece. Furthermore, the serialized data array size can be dynamic on a transmission cycle basis.

<sup>25</sup>A complex data element is an instance of a complex data type. Inside a complex data type, there are one or more data types (primitive data types), like in a C struct.

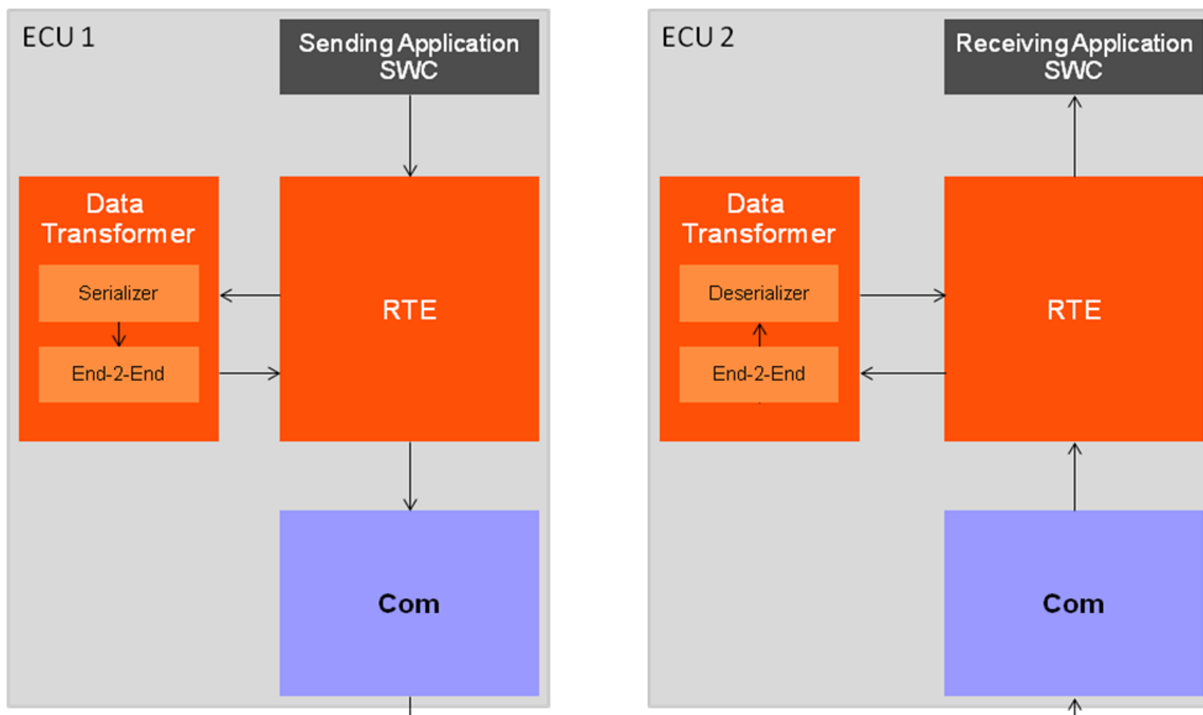

**Figure 2.20: RTE Data Transformer - Overview**

Based on Concept "Sender/Receiver Serialization", V0.51, R4.2 Rev 1, Page 31, Figure 8 "Use Case 1: Transmission of large composite data types over networks with large PDUs (e.g Ethernet)"

As illustrated in [Figure 2.20](#), the RTE Data Transformer accepts complex data (either a Sender/Receiver data element or a Client/Server operation with its arguments) from the RTE, performs a configurable chain of data transformations (such as Serialization, End-2-End Protection, Cryptographic functions, Compression) and provides the resulting byte array, which is finally transmitted to the receiver by COM (or RTE during intra-ECU communication). Data transformation for End-2-End Protection is implemented by the End-2-End Transformer<sup>26</sup>, which internally uses the End-2-End Library.

The complete configuration of the RTE Data Transformer is performed via AUTOSAR System Template for Inter-ECU communication and Software-Component Template for Intra-ECU communication. The resulting code is fully generated and executed via the RTE. The Software Components do not have to be aware of the specific protection mechanism used, unless detailed knowledge of the detected faults is required. The RTE Data Transformer can only be used in systems, where the integrity of operation of RTE is provided.

Note: The serialized data array size is not restricted by the PDU size of the inter-connection network, as large data arrays can be transmitted using existing transport protocols.

<sup>26</sup>CP\_SWS\_E2ETransformer[8], V0.9.1, R4.2 Rev 1

Note: The individual data transformations are performed on data arrays and not complex data elements, therefore serialization is the first and respectively last data transformation performed by the RTE Data Transformer.

### 2.4.3 Detection and Reaction

The End-to-End Communication Protection related features are implemented in AUTOSAR 4.0 as a standard library. This library provides End-2-End communication protection mechanisms that enable the sender to protect data prior to transmission and the receiver to detect and handle errors in the communication link at runtime.

When the End-2-End Library is used, the detection of communication faults is signaled to the receiver.

Note: The AUTOSAR Document "Explanation of Error Handling on Application Level"<sup>27</sup> provides additional information on error handling. Within the document it is explained how error handling can be performed and where the required data (e.g. substitute values) can be obtained from. Furthermore the document provides a detailed explanation (user's manual) on how OS-Application/Partition termination and restart in AUTOSAR is performed.

### 2.4.4 Limitations

1. The appropriate usage of the End-2-End Library alone is not sufficient to achieve a safe End-2-End communication. Solely the user is responsible to demonstrate that the selected profile provides sufficient error detection capabilities for the considered network (e.g. by evaluation hardware failure rates, bit error rates, number of nodes in the network, repetition rate of messages and the usage of a gateway).
2. A communication between Software Components over the RTE is more than a simple Point-to-Point connection. Further fault models have to be considered, such as RTE errors in Data Conversion, Filtering, missing notifications, wrong order of parameters in client-server communication and delays in transmission. Those failure modes also have to be considered during the development of a safety-relevant system.

Local RTE communication can be protected against some of the faults mentioned above by other mechanisms, such as an RTE which employs internal partitioning and other safety mechanisms and measures.

3. The use of the End-2-End protection for all Software Component communications of an ECU may be prohibitive due to runtime-overheads. Also, the limitations associated with the uniqueness of DataIDs may prevent this approach on Profile 1 and 2 due to masquerading.

---

<sup>27</sup>CP\_EXP\_ApplicationLevelErrorHandling[5], R4.2 Rev 1, Chapter 8, Chapter 10

4. The End-2-End Protection does not guarantee data actuality, because the End-2-End Profiles do not incorporate time stamps in the control data.

### 2.4.5 References to AUTOSAR Documents

Source: Requirements on AUTOSAR Features, V1.2.1, R4.1 Rev 2

AUTOSAR shall offer methods to protect safety related data communication against corruption

AUTOSAR shall provide end-to-end protection support as a library

AUTOSAR shall use hardware communication data integrity mechanisms

### 2.4.6 References to ISO26262

The following references to the ISO26262 standard are related to the aspects of freedom from interference for software components with different ASIL ratings. Concepts related to exchange of information are covered.

<i>ID</i>	<i>ISO26262 Reference</i>
03	Part 6: [D.2.1]
09	Part 6: [D.2.4]
10	Part 6: [7.4.12] NOTE 2, Detection of data errors

**Table 2.11: ISO26262 Exchange of Information References**

### 3 Functional Safety Measures

In addition to Functional Safety mechanisms provided by AUTOSAR, the development of safety-relevant software is supported by Functional Safety measures which originate from AUTOSAR.

#### 3.1 Functional Safety Measures of AUTOSAR

The following table provides a list of examples of ISO26262 Requirements mapped to the definition of AUTOSAR Basic Software.

ID	Functional Safety Measures	ISO Reference	AUTOSAR Requirement/Feature
001	Enforcement of strong typing	ISO26262-6 Table 1, 1c	FO_MMOD_MetaModel_059
002	Use of well-trusted design principles	ISO26262-6 Table 1, 1e	CP_EXP_LayeredSoftwareArchitecture_053
003	Use of unambiguous graphical representation	ISO26262-6 Table 1, 1f	Standard representation of the FO_MMOD_MetaModel_059
004	Use of naming conventions	ISO26262-6 Table 1,1h	AUTOSAR Application Interfaces definition: AUTOSAR_MOD_AItable.xls CP_EXP_AIUserGuide_442
005	Semi-formal Notations	ISO 26262-6 Table 2, 1c Semi-formal notations	FO_MMOD_MetaModel_059
006	Restricted size of interfaces	ISO26262-6 Table 3, 1c	Per domain, application interfaces were proposed: CP_EXP_AIbodyAndComfort_268 CP_EXP_AIChassis_270 CP_EXP_AIOccupantAndPedestrianSafety_271 CP_EXP_AIHMIMultimediaAndTelematics_272 CP_EXP_AIPowertrain_269
007	Loose coupling between software components	ISO26262-6 Table 3, 1e	CP_EXP_LayeredSoftwareArchitecture_053 Please see: Interfaces: General Rules Layer Interaction Matrix.
008	Restricted use of interrupts	ISO26262-6 Table 3, 1g	CP_EXP_InterruptHandlingExplanation_307
009	Detection of data errors	ISO 26262-6 [7.4.12] NOTE 2, Detection of data errors	CP_SWS_E2ELibrary_428 CP_SWS_CRCLibrary_016
010	Control flow monitoring	ISO 26262-6 [7.4.12] NOTE 2, Temporal monitoring of program execution	CP_SWS_WatchdogManager_080
011	Graceful degradation	ISO 26262-6 [7.4.12] NOTE 3	CP_EXP_LayeredSoftwareArchitecture_053 Please see: Integration and Runtime Aspects - Partitioning Example of restarting partition. CP_SWS_FunctionInhibitionManager_082





012	Interface test	ISO 26262-6 Table 7, 1k Table 10, 1b	Acceptance Test for the AUTOSAR Stack
013	Document Management	ISO26262-8 10.4.3-10.4.6	Fulfilled by AUTOSAR Quality Management

**Table 3.1: Mapping of ISO26262 Requirements to AUTOSAR Basic Software**

### 3.2 Traceability

Traceability is a prerequisite for the implementation of safety-relevant systems. AUTOSAR provides traceability from the AUTOSAR project objectives to the software specifications of the AUTOSAR architecture.

### 3.3 Development Measures and the Evolution of the Standard

The AUTOSAR standard follows a defined life cycle, which is enforced by a dedicated Change Management. Therefore, the AUTOSAR version which is used during the product development can be easily referenced.

Systematic Faults during product development can be reduced when a defined version of AUTOSAR is used, as the specifications, the interfaces and the behavior can be clearly established.

During the development of AUTOSAR specifications, a tracking of findings and bug fixes is performed with well-established tools ("Bugzilla"). Therefore it is possible to follow the incorporation of findings and bug fixes for the users of an AUTOSAR version well ahead series production.

In model-based development, a hierarchically structured model of function blocks with well-defined inputs and outputs is used to control complexity, to model the functionality and to support code generation. Please see ISO26262 Part 6, Annex B for details. Model-based development is supported due to the use of standardized interfaces and exchange formats, as well as due to the flexibility of the AUTOSAR methodology to support extensions.

The development process of AUTOSAR Specifications involves a comprehensive review process by multiple parties and work packages. The development milestones and the associated review process conditions are defined by AUTOSAR Quality Management.

AUTOSAR supports the argumentation of Freedom from Interference by providing functional safety mechanisms. Please see [chapter 2](#) for details on AUTOSAR Functional Safety Mechanisms.

AUTOSAR provides a clear definition of people assignment to work packages, based on the high expertise in the respective fields.

AUTOSAR provides a definition of the generic Software Architecture, based on modularity, formality and model-based development.

### **3.4 Functional Safety Measures not delivered by AUTOSAR**

Not all functional safety measures, which may be required for the development of safety-relevant applications, are delivered by AUTOSAR. Therefore the implementers of safety-relevant applications must ensure that the safety development life cycle is adequate.

As an example, the following functional safety measures are neither enforced nor delivered by AUTOSAR. This list does not imply completeness.

- The AUTOSAR specification does not define Safety Elements out of Context (SEooC) as described in ISO26262 Part 10, Chapter 9.
- The AUTOSAR Specification does not define the use of systematic and structured techniques for system examination, risk analysis and management, such as Hazard Analysis (HARA) and Hazard & Operability Analysis (HAZOP).
- No overall safety concept.
- No ASIL identification
- No dependent failure analysis is performed.
- No AUTOSAR safety case
- No confirmation measures
- No functional safety audits
- No conformance test
- Implementation techniques of Software Components such as low complexity, robustness, defensive programming, conventions, coding rules.
- Tracing of AUTOSAR features to Software Component implementation.
- Software integration testing
- Validation and Verification against the AUTOSAR specification.
- Defect reporting, tracking, resolution with regard to implementation.

### 3.5 Safety related Extensions of Methodology and Templates

The document "Safety Extensions" provides requirements upon extensions in AUTOSAR Methodology and Templates to realize and document functional safety of AUTOSAR systems. It specifies, how the AUTOSAR meta-model is to be used to enhance AUTOSAR models by information for functional safety. With the safety extensions, it is possible to:

- Describe and exchange the part of a (technical) safety concept of a system which is relevant for the realization of that system using the AUTOSAR architecture in a standardized form by means of the AUTOSAR templates.
- Provide traceability between safety-related elements of the AUTOSAR model and the safety requirements as part of the AUTOSAR templates.
- Declare the safety mechanisms/safety measures<sup>1</sup> that are applied for an AUTOSAR system as part of the AUTOSAR templates.
- Demonstrate the traceability between safety mechanisms/safety measures and safety requirements as part of the AUTOSAR templates.

All the safety measures and mechanisms described in "Overview of Functional Safety Measures in AUTOSAR" can be modeled and traced using the Safety Extensions as explained above.

### 3.6 Safety Use Case

The "Safety Use Case" is delivered as auxiliary document. It describes an exemplary safety related system using AUTOSAR based on the AUTOSAR guided tour example "Front Light Management".

The document provides an overview of a Functional safety concept as well as the derived Technical safety concept on ECU level and is focused on AUTOSAR relevant parts. The example follows the ISO 26262 standard, but does not cover all aspects and include all details.

The safety use case shall:

- Provide an example to discuss and verify safety related concepts within AUTOSAR,
- Identify improvement potential with respect to functional safety aspects in the current AUTOSAR specifications and methodology,
- Provide a guideline for safety analyses on top of AUTOSAR methodology

---

<sup>1</sup>In the context of this document, functional safety mechanisms are a concrete product part, such as memory protection. They are considered as specialization of functional safety measures, which also include process steps, like a review. This definition is in line with the definition given in ISO 26262 for these terms.



Therefore the example can be adapted or changed in future to include new AUTOSAR concepts or extend the complexity of the analyzed system.

## **3.7 Use of AUTOSAR features for functional safety**

AUTOSAR provides a broad variety of features, mechanisms and measures for functional safety. The following chapter will give hints to the use of AUTOSAR features, which were not primarily dedicated for functional safety, but can support the implementation of safety-relevant applications.

### **3.7.1 Timing Related Features**

Timing is an important property of embedded systems. Safe behavior requires that the systems actions and reactions are performed within the right time.

The right time can be described in terms of a set of timing constraints that have to be satisfied. However, an AUTOSAR software component cannot ensure proper timing by itself. It depends on proper support by the AUTOSAR runtime environment and the basic software. During integration the timing constraints of the software components need to be ensured.

The timing-related features address the following aspects to enable proper software component timing within the AUTOSAR framework:

- Provision of synchronized time-bases to provide a common notion of time across a network of ECUs;
- Provision of means for synchronized execution of runnables within an AUTOSAR ECU and across a network of AUTOSAR ECUs;
- Support by the AUTOSAR RTE, BSW and Methodology for deterministic timing of software components;
- Support by the AUTOSAR RTE and BSW to detect and control timing violations and prevent their propagation.

#### **3.7.1.1 Features related to the provision of synchronized time bases**

A synchronized time-base is a software time-base existing at a processing entity (e.g. a node of a distributed system) that is synchronized with software time-bases at different processing entities. A synchronized time-base can be achieved by time protocols or time agreement protocols that derive the synchronized time-base in a defined way from one or more physical time-bases. Examples are the network time protocol (NTP) and FlexRay time agreement protocol.

The synchronization will apply to the clock rate and optionally apply also to the clock absolute value.

A synchronized time-base allows synchronized action of the processing entities. Synchronized time-bases are often called "global time", as e.g. the so called "FlexRay global time". We do not use the term "global time" here because a single ECU sometimes has to cope with several synchronized time-bases which may vary in terms of rate and absolute value.

The synchronized time bases are established by the synchronized time-base manager BSW module.

In the AUTOSAR ECU Architecture the "Synchronized Time-base Manager" BSW module implements an AUTOSAR Service as indicated in Figure 3.1.

The application can access the AUTOSAR Service "Synchronized Time-Base Manager" via service ports with standardized AUTOSAR Interfaces.

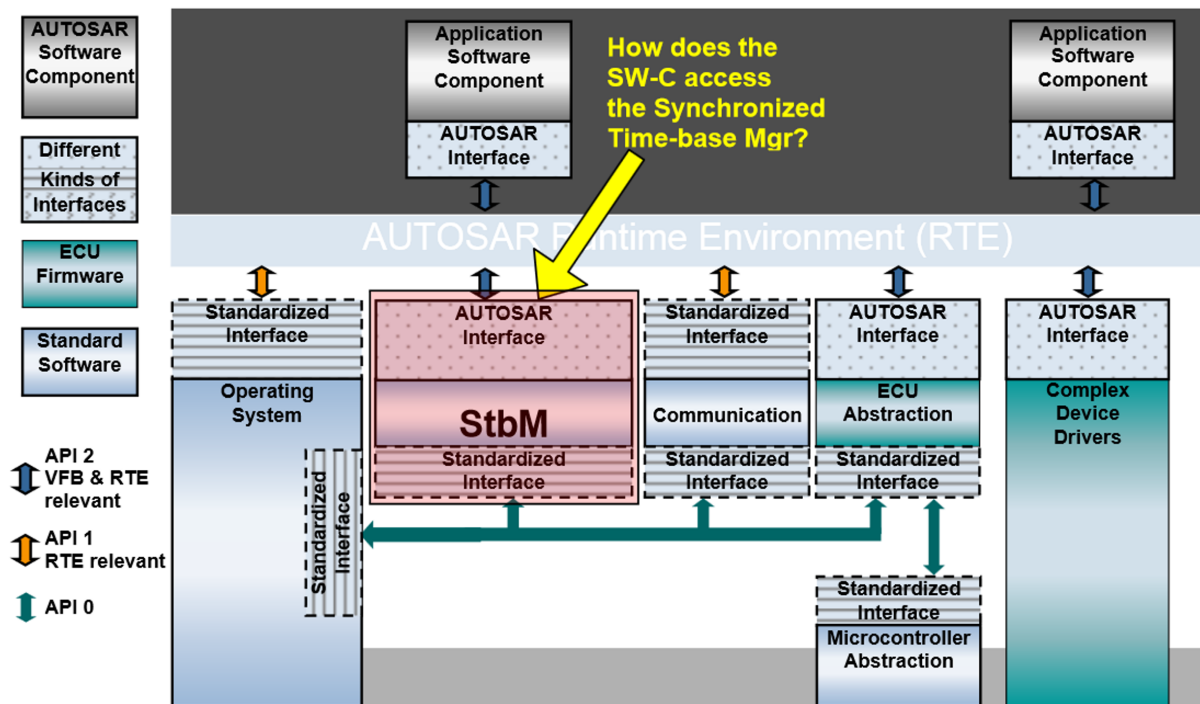

**Figure 3.1: The Synchronized Time - Base Manager in the ECU architecture**

CP\_SWS\_SynchronizedTimeBaseManager[9], V1.2.1, R4.2 Rev 2, Chapter 7.6.1 Architecture

Different types of customers will use the synchronized time-bases: triggered customers, active customers and notification customers. Triggering customers (runnables) is done via the OS.

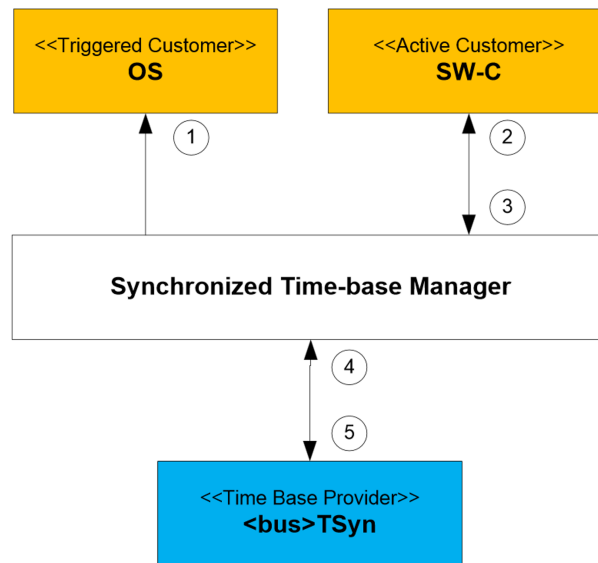

**Figure 3.2: Synchronized Time-base Manager as broker**

CP\_SWS\_SynchronizedTimeBaseManager[9], V1.2.1, R4.2 Rev 2, Chapter 1.2 Functional Overview

The Synchronized Time-base Manager itself does not provide means like network time protocols or time agreement protocols to synchronize its (local) time bases to time bases on other nodes. It interacts with the <bus>TSyn modules of the BSW to achieve such synchronization.

### 3.7.1.1.1 Provision of a synchronized time-base within a cluster

#### 3.7.1.1.1.1 Coverage Criteria of the Feature

Constraint: Provision of synchronized time bases is restricted to FlexRay, CAN, Ethernet and TTCAN clusters in AUTOSAR Release 4.2.2

The feature "Provision of a synchronized time-base within a cluster" is considered fulfilled if

ID	Description
RS_BRF_00120_CC01	There are means to provide the synchronized time base for FlexRay, CAN, Ethernet and TTCAN clusters.
RS_BRF_00120_CC02	The time base is provided in a dependable way and faults are detected and handled.

**Table 3.2: Coverage Criteria - Provision of a synchronized time-base within a cluster**

#### 3.7.1.1.1.2 Coverage justification

These 2 items are covered as follows

Coverage Criteria	Coverage Justification		
	BSW module	Requirements	Justification
RS_BRF_00120_CC01	CP_SWS_Synchronized-TimeBaseManager_421	SRS_StbM_20005, SWS_StbM_00050, SWS_StbM_00080, SWS_StbM_00081, SWS_StbM_00015	Means to provide a synchronized time base for FlexRay and TTCAN clusters: A module "synchronized time-base manager" is introduced in the AUTOSAR basic software. This Module acquires the time base from the FlexRay or TTCAN interface.
RS_BRF_00120_CC02	AUTOSAR_SRS_SynchronizedTimeBaseManager CP_SWS_Synchronized-TimeBaseManager_421 AUTOSAR_SRS_SynchronizedTimeBaseManager CP_SWS_Synchronized-TimeBaseManager_421	(SRS_StbM_20007, SWS_StbM_00030, SWS_StbM_00031, SWS_StbM_00032, SWS_StbM_00033, SWS_StbM_00034, SWS_StbM_00035, SWS_StbM_00036) SRS_StbM_20007, SWS_StbM_00030, SWS_StbM_00031, SWS_StbM_00032, SWS_StbM_00033, SWS_StbM_00034, SWS_StbM_00035, SWS_StbM_00036	Provision of dependable time base and fault detection and handling: <ul style="list-style-type: none"> <li>• The Synchronized Time-base Manager continuously provides the definition of time. If synchronization is not specified or temporarily not available, the local time is provided instead.</li> <li>• The Synchronized Time-base Manager detects loss and re-establishment of synchronized time-bases and erroneous customer calls and reports such faults to the DEM and the notification customers.</li> </ul>

**Table 3.3: Coverage Justification - Provision of a synchronized time-base within a cluster**

### 3.7.1.1.2 Services for accessing to synchronized time-bases

#### 3.7.1.1.2.1 Coverage Criteria of the Feature

ID	Description
RS_BRF_00127_CC01	There are means that customers can use the synchronized time base. The following types of customers are to be considered: triggered customers, active customers and notification customers.

**Table 3.4: Coverage Criteria - Services for accessing to synchronized time-bases**

#### 3.7.1.1.2.2 Coverage justification

This item is covered as follows

Coverage Criteria	Coverage Justification		
	BSW module	Requirements	Justification
RS_BRF_00127_CC01	SynchronizedTimeBase Manager CP_SRS_OS_008 CP_SWS_Synchronized- TimeBaseManager_421 CP_SRS_OS_008 AUTOSAR_SRS_ SynchronizedTimeBase Manager CP_SWS_Synchronized- TimeBaseManager_421	SRS_StbM_20001, SRS_ StbM_20002, SRS_Stb M_20009, SRS_Os_11002, SWS_StbM_00020, SWS_ StbM_00022, SWS_Stb M_00025, SWS_Stb M_00026, SWS_Stb M_00028, SWS_Stb M_00029, SWS_Stb M_00037, SWS_Stb M_00038, SWS_Stb M_00077, SWS_Stb M_00082, SWS_Stb M_00083, SWS_Stb M_00084, SWS_Stb M_00085, SWS_Os_00206, SWS_Os_00201, SWS_ Os_00013, SWS_ Os_00199, SWS_ Os_00227, SWS_ Os_00429, SWS_ Os_00430, SWS_ Os_00431, SWS_ Os_00462, SWS_ Os_00463, SWS_ Os_00435, SWS_ Os_00415, SWS_ Os_00416, SWS_ Os_00436, SWS_ Os_00437, SWS_ Os_00438, SWS_ Os_00417, SWS_ Os_00418, SWS_ Os_00419, SWS_ Os_00420, SWS_ Os_00421, SWS_Os_00422 SRS_StbM_20001, SRS_ StbM_20003, SRS_Stb M_20008, SRS_Stb M_20010, SWS_Stb M_00020, SWS_Stb M_00025, SWS_Stb M_00026, SWS_Stb M_00028, SWS_Stb M_00029, SWS_Stb M_00037, SWS_Stb M_00038, SWS_Stb M_00082, Chapter 11 in SWS StbM.	Means that customers can use the synchronized time base: <ul style="list-style-type: none"> <li>• For the triggered              customer the BSW              module "Synchronized              Time-base Manager"              provides a              synchronization between              the synchronized              time-base and the time              base used by the OS for              scheduling, i.e. the OS              counter</li> <li>• For the active customer              and the notification              customer it means to              provide a service              interface via the RTE for              SW-C or an API for BSW</li> </ul>

**Table 3.5: Coverage Justification - Services for accessing to synchronized time-bases**

### 3.7.1.1.3 Sync AUTOSAR OS with Global Time from providing bus system in a well-defined way

#### 3.7.1.1.3.1 Coverage Criteria of the Feature

The feature "Sync AUTOSAR OS with Global Time from existent bus system in a well-defined way" is considered to be covered if

ID	Description
RS_BRF_00278_CC01	There are means to provide the synchronized time base for FlexRay, CAN, Ethernet and TTCAN clusters
RS_BRF_00278_CC02	Synchronization between the synchronized time-base and the time base used by the OS for scheduling is provided.

**Table 3.6: Coverage Criteria - Sync AUTOSAR OS with Global Time from providing bus system in a well-defined way**

### 3.7.1.1.3.2 Coverage justification

These 2 items are covered as follows

.

Coverage Criteria	Coverage Justification		
	BSW module	Requirements	Justification
RS_BRF_00278_CC01			is covered by RS_BRF_00120_CC01 (for further traceability see there)
RS_BRF_00278_CC02			is covered by RS_BRF_00127_CC01 (a) (for further traceability see there)

**Table 3.7: Coverage Justification - Sync AUTOSAR OS with Global Time from providing bus system in a well-defined way**

### 3.7.1.2 Features related to synchronization of processing of asynchronous processing units

To synchronize runnables within a set of SW-Cs, they have to be attached to a synchronized RTE timing. For this it must be possible to specify that a set of RTE timing events (with the same period) within a SW-C composition are synchronized.

Synchronization is possible within a single micro controller as well as across networks.

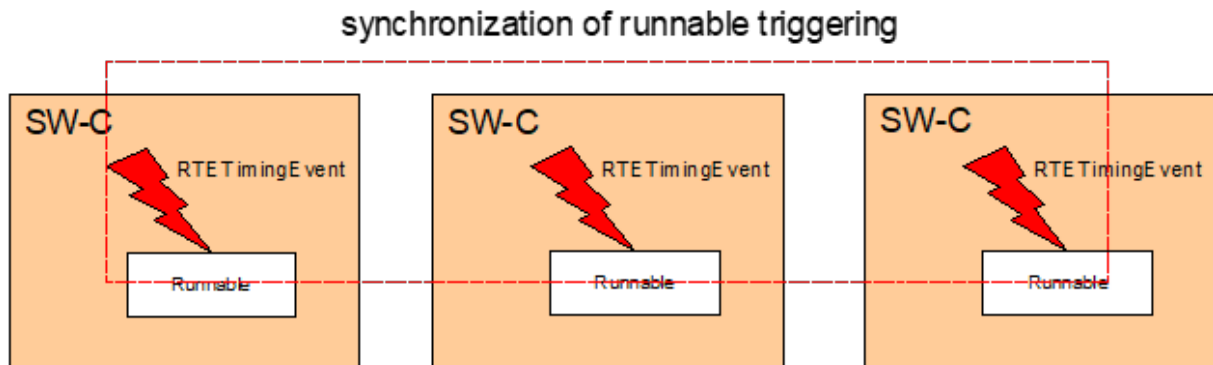

**Figure 3.3: Synchronization of processing of asynchronous processing units - Overview**

**3.7.1.2.1 Services for synchronization of SW-Cs**

**3.7.1.2.1.1 Coverage Criteria of the Feature**

Constraints:

- The feature is restricted to RTE timing events only. The events are used to trigger runnables.
- The synchronization of runnables that are controlled by different AUTOSAR OS instances (e.g. if they are running on different ECUs or different  $\mu$ Cs within one ECU) is only possible if they are located on ECUs within the same FlexRay, CAN, Ethernet or TTCAN network cluster.

The feature "Services for synchronization of SW-Cs" is considered to be covered if

ID	Description
RS_BRF_00126_CC01	<ul style="list-style-type: none"> <li>• There are technical means to trigger runnables in a synchronized way, i.e. with minimum jitter and (in case of serialized processing) fixed execution order. The following cases have to be distinguished here:                             <ul style="list-style-type: none"> <li>– The runnables which are triggered by the synchronized timing events are mapped to the same operating system task.</li> <li>– The runnables which are triggered by the synchronized timing events are mapped to different operating system tasks within one OS application.</li> <li>– The runnables which are triggered by the synchronized timing events are mapped to different operating system tasks in different OS applications on the same microcontroller core.</li> <li>– The runnables which are triggered by the synchronized timing events are mapped to different operating system tasks in different OS applications on different cores of the same microcontroller.</li> <li>– The runnables which are triggered by the synchronized timing events are mapped to different operating system tasks in different OS applications on different microcontrollers within one ECU.</li> </ul> </li> </ul> <p>The runnables which are triggered by the synchronized timing events are mapped to different operating system tasks in different OS applications on different microcontrollers within different ECUs.</p>



RS_BRF_00126_CC02	The AUTOSAR methodology supports the specification of synchronization constraints for RTE timing events.
-------------------	--

**Table 3.8: Coverage Criteria - Services for synchronization of SW-Cs**

### 3.7.1.2.1.2 Coverage justification

These 2 items are covered as follows:

Coverage Criteria	Coverage Justification		
	BSW module	Requirements	Justification
RS_BRF_00126_CC01	CP_SRS_RTE_083 CP_SWS_RTE_084 CP_SRS_RTE_083 CP_SWS_RTE_084	SRS_Rte_00232, rte_sws_7804, rte_sws_7805  SRS_Rte_00232, rte_sws_7804  covered by RS_BRF_00120 and RS_BRF_00127	a-c. In these cases the RTE configuration and RTE generation will take care of the synchronization of the runnables by either locating the runnables to the same task, using the same Os Alarm or OsScheduleTable ExpiryPoint to implement all TimingEvents, or using different OsAlarms or OsScheduleTableExpiryPoints in different OsSchedule Tables based on different OS counters but with same period and max value.  d-f. In these cases, the RTE configuration and RTE generation will take care of the synchronization of the runnables by using OsScheduleTable ExpiryPoints in different explicitly synchronized OsSchedule Tables (). Furthermore the synchronized time-base manager will take care of the explicit synchronization of the schedule tables and of the establishment of the common synchronized time base.
RS_BRF_00126_CC02	FO_RS_TimingExtensions_410	RSTM002 chapter 3.7 in	The specification of synchronization constraints is supported by the timing extensions.

**Table 3.9: Coverage Justification - Services for synchronization of SW-Cs**

### 3.7.1.3 Features to allow time deterministic implementation of applications

Time deterministic implementation of applications requires to be able to specify timing constraints and analyze timing properties at different stages of development, i.e. during



virtual integration on VFB level, development of SW-Cs, and finally the integration of SW-Cs into ECUs and of ECUs into a system of ECUs.

Furthermore, the runtime environment must provide suitable mechanisms to enforce deterministic timing.

The following Figure illustrates a specification of VFB timing.

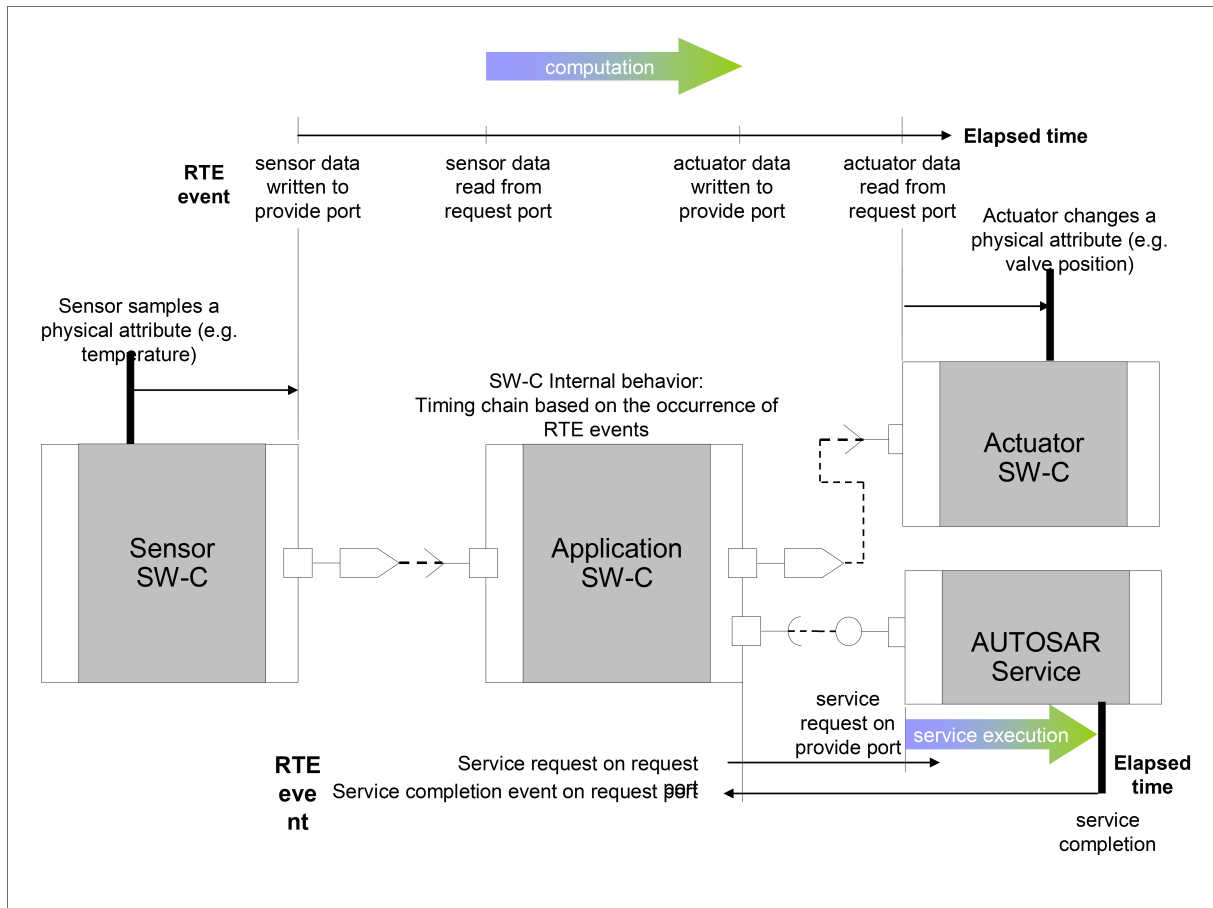

**Figure 3.4: VFB timing - Overview**

### 3.7.1.3.1 Support for timing constraints

#### Coverage Criteria of the Feature

The feature "Support for timing constraints" is considered to be covered if

ID	Description
RS_BRF_00122_CC01	<ul style="list-style-type: none"> <li>• It is possible to specify the following timing constraints:               <ul style="list-style-type: none"> <li>– a timing relation (min, max, nominal) between RTE events with a lower and upper bounds</li> <li>– the time relation between a physical sensor acquisition (or a physical actuator change) and the availability of the corresponding data element on the port of a sensor SW-C (or actuator SW-C)</li> <li>– constraints on the execution time (min,max) of a runnable</li> <li>– constraints on the triggering rate for a runnable</li> <li>– the end-to-end timing related to external communication</li> <li>– the end-to-end timing related to IO accesses</li> </ul> </li> </ul>
RS_BRF_00122_CC02	<ul style="list-style-type: none"> <li>• The scheduling strategies allow to enforce these timing constraints by providing the following mechanisms:               <ul style="list-style-type: none"> <li>– specification of non-preemptive execution of a code segment</li> <li>– static time-based scheduling for all tasks or for a subset of the tasks</li> <li>– the possibility to replace ISRs with time-based polling routines</li> <li>– fixed-priority based scheduling</li> <li>– the possibility of preemption of lower-priority tasks by higher-priority tasks</li> </ul> </li> </ul>

**Table 3.10: Coverage Criteria - Support for timing constraints**

These 2 items are covered as follows:

Coverage Criteria	Coverage Justification		
	BSW module	Requirements	Justification
RS_BRF_00122_CC01	FO_RS_TimingExtensions_410 CP_TPS_TimingExtensions_411 FO_RS_TimingExtensions_410 CP_TPS_TimingExtensions_411 FO_RS_TimingExtensions_410 CP_TPS_TimingExtensions_411 FO_RS_TimingExtensions_410 CP_TPS_TimingExtensions_411 FO_RS_TimingExtensions_410 CP_TPS_TimingExtensions_411 FO_RS_TimingExtensions_410 CP_TPS_TimingExtensions_411 FO_RS_TimingExtensions_410 CP_TPS_TimingExtensions_411	RSTM002, RSTM003, RSTM004, sections 3.3, 3.6 in CP_TPS_TimingExtensions_411 RSTM012 section 3.6 in CP_TPS_TimingExtensions_411 RSTM001, RSTM002 sections 3.2, 3.6 CP_TPS_TimingExtensions_411 RSTM001, RSTM002 sections 3.2, 3.5 in CP_TPS_TimingExtensions_411 RSTM001, RSTM002 sections 3.2, 3.6 in CP_TPS_TimingExtensions_411 RSTM001, RSTM002 RSTM001, RSTM004 sections 3.2, 3.6 in CP_TPS_TimingExtensions_411	<ul style="list-style-type: none"> <li>• The specification of timing constraints and properties is possible using the AUTOSAR timing extensions as follows:               <ul style="list-style-type: none"> <li>– The AUTOSAR timing extensions allow the specification of event chains and of the triggering behavior of event chains.</li> <li>– The AUTOSAR timing extensions allow the specification of sensor/ actuator delays.</li> <li>– The AUTOSAR timing extensions allow the specification of timing events of SW-C internal behavior like start and termination of runnables and the specification of timing constraints related to these.</li> <li>– The AUTOSAR timing extensions allow to specify event triggering constraints.</li> </ul> </li> </ul>



△

			<p>△</p> <ul style="list-style-type: none"> <li>– The AUTOSAR timing extensions allow to specify timing events related to bus communication and timing constraints for these.</li> <li>– The AUTOSAR timing extensions allow to specify input/output latency constraints.</li> </ul>
RS_BRF_00122_CC02	CP_SRS_OS_008 CP_SWS_OS_034 CP_SRS_OS_008 CP_SWS_OS_034 CP_SRS_OS_008 CP_SWS_OS_034	SRS_Os_00097 SWS_Os_00001 SRS_Os_00098 SWS_Os_00002, SWS_Os_00007 SRS_Os_00097 SWS_Os_00001	<ul style="list-style-type: none"> <li>• The OS and the RTE provide the necessary scheduling mechanisms to enforce timing as follows:               <ul style="list-style-type: none"> <li>– Non-preemptive scheduling is supported by OSEK OS.</li> <li>– The Operating System provides statically configurable schedule tables based on time tables.</li> </ul> </li> </ul> <p>c.-e. These features are available with OSEK OS.</p>

**Table 3.11: Coverage Justification - Support for timing constraints**

### 3.7.1.3.2 Responsiveness to external events

Coverage Criteria of the Feature

The feature "Responsiveness to external events" is considered to be covered if

ID	Description
RS_BRF_00123_CC01	External events can be used as an initiator for scheduling.

**Table 3.12: Coverage Criteria - Responsiveness to external events**

This item is covered as follows:

Coverage Criteria	Coverage Justification		
	BSW module	Requirements	Justification
RS_BRF_00123_CC01	CP_SRS_RTE_083 CP_SWS_RTE_084	SRS_Rte_00162, SRS_Rte_00216, rte_sws_7229, rte_sws_7212, rte_sws_7213, rte_sws_7214, rte_sws_7543, rte_sws_7215, rte_sws_7216, rte_sws_7218, rte_sws_7200, rte_sws_7201, rte_sws_7207, rte_sws_7514, rte_sws_7542, rte_sws_7544, rte_sws_7545, rte_sws_7548, rte_sws_7546, rte_sws_7549, rte_sws_7282, rte_sws_7283	<ul style="list-style-type: none"> <li>The RTE supports the use of external events as trigger execution of runnables and BSW schedulable entities.</li> </ul>

**Table 3.13: Coverage Justification - Responsiveness to external events**

### 3.7.1.4 Features related to protection against timing violation

Depending on the scalability class, the AUTOSAR OS can provide protection mechanisms against timing violation. As the OS is only aware of tasks and not of runnables, the OS provides protection mechanisms on task level with the fault containment region being the OS application.

Timing protection of SW-Cs at runtime requires monitoring of runnables and preventing the propagation of timing faults from one SW-C to another. If SW-Cs require protection from each other, then their runnables have to be placed into different OS applications which implies that they are placed into different task bodies.

RE2 is mapped alone in a task for monitoring purpose but the order of execution and the non-preemption with RE1 and RE3 are still under control

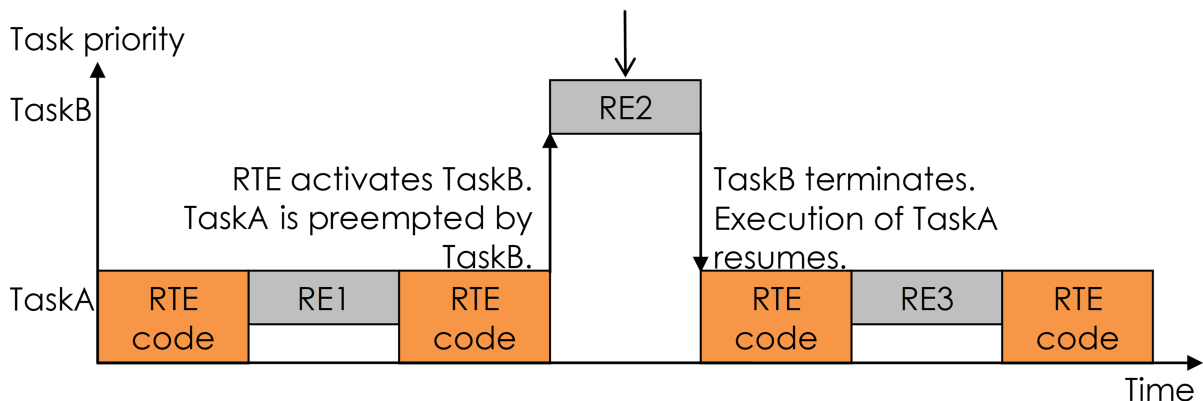

**Figure 3.5: Task Execution - Example**

Note: Please see the [subsubsection 2.2.2.3](#) "Timing Protection of the Operating System".

### 3.7.1.4.1 Runtime timing protection and monitoring

#### Coverage Criteria of the Feature

The feature "Runtime timing protection and monitoring" is considered to be covered if:

ID	Description
RS_BRF_00121_CC01	The operating system provides mechanisms to detect timing faults on task level and to prevent timing faults from propagating from one OS application to another
RS_BRF_00121_CC02	The RTE provides means to make use of the task level OS timing protection mechanisms for runnables.

**Table 3.14: Coverage Criteria - Runtime timing protection and monitoring**

These 2 items are covered as follows:

Coverage Criteria	Coverage Justification		
	BSW module	Requirements	Justification
RS_BRF_00121_CC01	CP_SRS_OS_008 CP_SWS_OS_034	SRS_Os_11008, SWS_Os_00028, SWS_Os_00089, SWS_Os_00033, SWS_Os_00037, SWS_Os_00048, SWS_Os_00064, SWS_Os_00465, SWS_Os_00469, SWS_Os_00470, SWS_Os_00471, SWS_Os_00472, SWS_Os_00473, SWS_Os_00474	The OS provides means to monitor execution time budgets, task activation frequencies, and resource locking times, and allows preventing fault propagation by stopping OS applications and freeing locked resources
RS_BRF_00121_CC02	CP_SRS_RTE_083 CP_SWS_RTE_084	SRS_Rte_00160, SRS_Rte_00193, rte_sws_2697, sws_rte_7800, sws_rte_7802 in 084	The RTE provides debounced start of runnable entities and supports runnable execution chaining in order to allow a separation of runnables (which usually are chained within one task body) into chained tasks which then can be monitored by the task level OS mechanisms

**Table 3.15: Coverage Justification - Runtime timing protection and monitoring**

### 3.7.1.4.2 Monitoring of local time

This feature is considered fulfilled as the functionality can be realized within the software component. There is no need for specific mechanisms in AUTOSAR.

**3.7.2 E-Gas Monitoring Related Features**

The E-Gas Monitoring Concept is a safety concept applicable e.g. for diesel and gasoline engine management. It is standardized by the AKEGAS working group and not part of the AUTOSAR standard.

The possible realizations of the e-Gas monitoring concept in the context of AUTOSAR software architecture have been investigated. The features of this section ensure that a design approach as shown in the following figure can be used with AUTOSAR Release 4.0.

In the design approach shown below, the monitoring related software is located in a Complex Driver (CDD). A CDD allows a direct access to the related inputs and outputs.

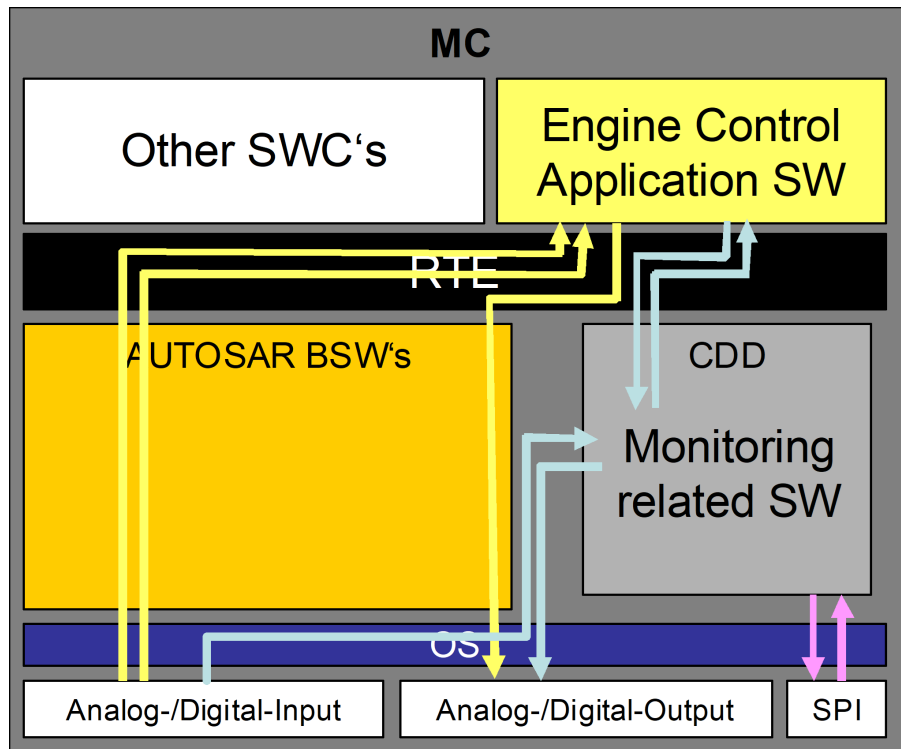

**Figure 3.6: E-Gas Monitoring Concept - Overview**

**3.7.2.1 Communication protections against corruption and loss of data**

Coverage Criteria of the Feature

Constraint: It is assumed that end-to-end protection is used to protect the transmission of the necessary signals from the sender to the receiver (e.g. monitoring software).

The feature "Communication protection against corruption and loss of data" is considered fulfilled if the complete path of the data read by the Complex Drivers is protected against loss and corruption, which means:

ID	Description
RS_BRF_00243_CC01	the loss and corruption of data is detected if it happens on the way from the emitter node to the BSW driver of the receiver node
RS_BRF_00243_CC02	the loss and corruption of data is detected if it happens on the way from the Bus Specific interface to the Complex Driver

**Table 3.16: Coverage Criteria - Communication protections against corruption and loss of data**

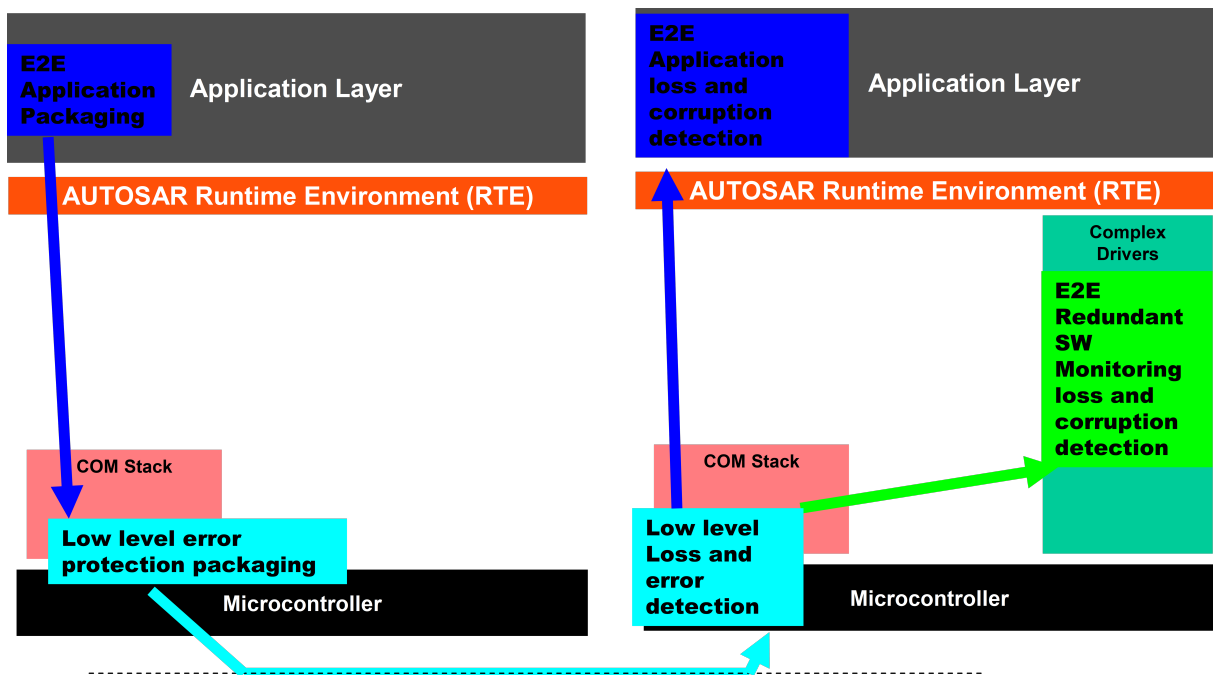

**Figure 3.7: E-Gas Monitoring Concept - Communication protections against corruption and loss of data**

These 2 items are covered as follows

Coverage Criteria	Coverage Justification		
	BSW module	Requirements	Justification
RS_BRF_00243_CC01	CP_SRS_Libraries_314 CP_SWS_E2ELibrary_428	SRS_LIBS_08527, SRS_LIBS_08536, SWS_E2E_00020, E2E0023, E2E0026, E2E0030, E2E0043	the detection of loss and corruption of data between the emitter node and the BSW of the receiver node is ensured by the protection mechanisms available with CAN or FlexRay communication networks (CRC, checksum, process counters)





RS_BRF_00243_CC02	CP_SRS_Libraries_314 CP_SWS_E2ELibrary_428	SRS_LIBS_08535, E2E0026, E2E0030	the detection of loss and corruption of data between the Bus Specific Interface and the Complex Driver is ensured by the access of the Complex Driver to the frame payload dedicated to Safety and the application dependent end-to-end protection.
-------------------	---	-------------------------------------	---

**Table 3.17: Coverage Justification - Communication protections against corruption and loss of data**

### 3.7.2.2 Priority access to SPI bus

Coverage Criteria of the Feature

The feature "Priority access to SPI bus is considered fulfilled if:

ID	Description
RS_BRF_00251_CC01	The Monitoring SW placed in the Complex Drivers SW can have access the SPI bus with a bounded delay, this means that the priority access is scheduled so that the delay of the access to the SPI from CDD is bounded.

**Table 3.18: Coverage Criteria - Priority access to SPI bus**

This item is covered as follows:

Coverage Criteria	Coverage Justification		
	BSW module	Requirements	Justification
RS_BRF_00251_CC01	CP_SRS_SPIHandlerDriver_077 CP_SWS_SPIHandlerDriver_038	SRS_Spi_12037, SWS_Spi_00002 SWS_Spi_00014, SWS_Spi_00093, SWS_Spi_00059	Priority access is defined in and provided by the SPI Handler Driver

**Table 3.19: Coverage Justification - Priority access to SPI bus**

### 3.7.2.3 Testing and monitoring of I/O data and I/O HW

Coverage Criteria of the Feature

The feature "Testing and monitoring of I/O data and I/O HW" is considered fulfilled if:



ID	Description
RS_BRF_00248_CC01	The Monitoring SW placed in the Complex Drivers SW can perform test of the related A/D-Converter without disturbing a data acquisition related to normal operation.
RS_BRF_00248_CC02	The Monitoring SW placed in the Complex Drivers can directly perform tests of the safety-related actuators (throttle, injectors) of the shut-off path.

**Table 3.20: Coverage Criteria - Testing and monitoring of I/O data and I/O HW**

These 2 items are covered as follows:

Coverage Criteria	Coverage Justification		
	BSW module	Requirements	Justification
RS_BRF_00248_CC01			Support for ADC tests is ensured because it doesn't have any impact on ADC drivers.
RS_BRF_00248_CC02			The drivers dedicated to the injectors and the throttle actuator are Complex Drivers and therefore can implement the necessary test procedures.

**Table 3.21: Coverage Justification - Testing and monitoring of I/O data and I/O HW**

### 3.7.2.4 Ability to make an AUTOSAR application compatible to the e-Gas monitoring Concept

Coverage Criteria of the Feature

The feature [RS\_BRF\_00301] Ability to make an AUTOSAR application compatible to the e-Gas monitoring Concept is covered if:

ID	Description
RS_BRF_00301_CC01	The arguments of the [RS_BRF_00243], [RS_BRF_00251], [RS_BRF_00248], [BRF00244], [BRF00245], [BRF00246], [BRF00247], [BRF00249], [BRF00250] are fulfilled.
RS_BRF_00301_CC02	The e-Gas Monitoring SW placed in the Complex Drivers can access to the raw values of the ADC inputs.
RS_BRF_00301_CC03	The e-Gas Monitoring SW placed in the Complex Drivers can access to the raw values of the DIO inputs.
RS_BRF_00301_CC04	The e-Gas Monitoring SW placed in the Complex Drivers can access to the raw values of the PWM inputs.

**Table 3.22: Coverage Criteria - Ability to make an AUTOSAR application compatible to the e-Gas monitoring Concept**

These 4 items are covered as follows

Coverage Criteria	Coverage Justification		
	BSW module	Requirements	Justification
RS_BRF_00301_CC01			The features [RS_BRF_00243], [RS_BRF_00251], [RS_BRF_00248], [BRF00244], [BRF00245], [BRF00246], [BRF00247], [BRF00249], [BRF00250] are fully covered.
RS_BRF_00301_CC02	CP_SRS_ADCDriver_111 CP_SWS_ADCDriver_010	SRS_SPAL_12063, SWS_Adc_00113	ADC Drivers can provide raw data directly to the Complex Drivers
RS_BRF_00301_CC03	CP_SRS_DIODriver_191 CP_SWS_DIODriver_020	SRS_Dio_12352, SWS_Dio_00083	DIO Drivers can provide raw data directly to the Complex Drivers
RS_BRF_00301_CC04	CP_SRS_ICUDriver_112 CP_SWS_ICUDriver_023	SRS_Icu_12436 SWS_Ico_00211, SWS_Ico_00342, SWS_Ico_00084, SWS_Ico_00344, SWS_Ico_00106, SWS_Ico_00345, SWS_Ico_00180, SWS_Ico_00181, SWS_Ico_00022, SWS_Ico_00048, ICU272, ICU265 SRS_Icu_12369 SWS_Ico_00021	ICU Drivers can provide raw data directly to the Complex Drivers

**Table 3.23: Coverage Justification - Ability to make an AUTOSAR application compatible to the e-Gas monitoring Concept**

## 4 Hardware Diagnostics

Modern microcontrollers for safety-relevant applications are highly complex devices. To ensure that the desired level of integrity is achieved by the microcontroller as part of a safety-relevant system, integration and use of functional safety mechanisms and measures in hardware and software is required.

Microcontrollers must support the premise of the safety-relevant system, that the provided functionality can be trusted. Execution of Hardware Diagnostic mechanisms can support this premise. This chapter provides an overview of how hardware diagnostics are supported using AUTOSAR.

### 4.1 Core Test

The general objective of test by software is to detect failures in processing units which lead to incorrect results. Core Test performs test by software of processing units during microcontroller start-up and runtime.

#### 4.1.1 Fault Models

According to ISO 26262<sup>1</sup>, detection of failures in the following parts of the processing units are typically considered for the derivation of diagnostic coverage. The following table provides a preliminary mapping between ISO26262 and Core Test requirements [10] [11].

ID	Processing unit parts	Core Test SRS Requirements
001	ALU Data Path	Core ALU Test
002	Registers (general purpose registers bank, DMA transfer registers etc.), internal RAM	Core Register Test
003	Address calculation (Load/Store Unit, DMA addressing logic, memory and bus interfaces)	Core Address Generator Core Memory Interfaces Memory Management/Protection Unit (MMU/MPU) Cache Controller
004	Interrupt Handling	Core Interrupt and Exception Detection
005	Control Logic (Sequencer, coding and execution logic including flag registers and stack control)	-
006	Configuration Registers	-
007	Other sub-elements not belonging to previous classes	-

**Table 4.1: Mapping between Processing Unit parts and Core Test requirements**

<sup>1</sup>[ISO 26262-5, Annex D] Table D.1 Volatile Memory

### 4.1.2 Description

The Core Test Driver is an AUTOSAR Basic Software Module which accesses the microcontroller core directly without intermediate software layers. It is located in the Abstraction Layer (MCAL).

The Core Test Driver provides several tests to verify dedicated core functionality like e.g. general purpose registers or Arithmetical and Logical Unit (ALU). Furthermore, the Core Test Driver provides services for configuring, starting, polling, terminating and notifying applications about Core Test results. It also provides services for returning test results in a predefined way.

The Core Test Driver can be used during ECU power-up and during application runtime. However it is assumed that each hardware functional block of the core under test can be accessed by the Core Test Driver exclusively.

### 4.1.3 Detection and Reaction

If the execution of the Core Test Driver is to be embedded into a system safety architecture concept, then it is up to the user of the Core Test Driver to choose a suitable test combination and scheduled execution order to fulfill the safety requirements of the system.

Core Test reports errors in dedicated memory and bus interfaces (e.g. Tightly Coupled Memories, caches, systems bus) and dedicated supporting functionality (e.g. interrupt controller) to the diagnostic event manager (DEM) as production errors.

Errors inside the CPU (e.g. ALU, Prefetch queue, registers) cannot be reliably reported to DEM, as these faults affect the correct operation of the Core itself.

### 4.1.4 Limitations

1. Transient faults are not covered by Core Test.

The Core test can be used to detect static hardware errors during power-up and at runtime. Transient faults and intermittent faults are not covered and cannot be reliably detected by Core Test.

2. Core Test implementations may be limited to execution during start-up/power-up.

Core Test requires exclusive access to local core resources to avoid unwanted behavior and interference between test and application during runtime.

Currently, there is no resource managing entity in AUTOSAR upper layers to support exclusive access to shared resources.

3. Test results are only available to the core which executes Core Test.

MCAL drivers intentionally miss the ability of accessing test results being executed on other cores. Currently, there is no test managing entity in AUTOSAR upper layers to handle test result processing.

4. Core Test cannot report detected faults reliably.

Faults within the CPU itself (e.g. ALU, MAC, Registers) cannot be reliably reported to DEM, as they are being processed by the same faulty CPU.

**4.1.5 References to AUTOSAR Documents**

Source: Requirements on Core Test, V1.4.0, R4.2 Rev 1

Core Register Test Shall Be Available

Core Interrupt and Exception Detection Tests Shall Be Available

Core ALU Test Shall Be Available

Core Address Generator Test Shall Be Available

Core Memory Interfaces Test Shall Be Available

Memory Management/Protection Unit (MMU/MPU) Test Shall Be Available

Cache Controller Test Shall Be Available

Shared Resources to Be Tested Shall Be Made Exclusively Available to Test

Faults Shall Be Treated as Production Errors

**4.1.6 References to ISO26262**

The following references to the ISO26262 standard are related to the aspects of test by software for Processing Units.

<i>ID</i>	<i>ISO26262 Reference</i>
010	Part 5: [D.2.3.1] Self Test by software
011	Part 11: [Table 34] Combinatorial and sequential logic
012	Part 5: [Table D.4] Processing Units
013	Part 5: [Table D.1] Analysed failure modes

**Table 4.2: ISO26262 Core Test References**

**4.2 RAM Test**

The general objective of RAM Test is to detect permanent failures which can cause corruption in the volatile memory.

### 4.2.1 Fault Models

According to ISO 26262<sup>2</sup>, detection of the following failures in the volatile memory is typically considered for the derivation of diagnostic coverage. The following table provides a preliminary mapping between ISO26262 and RAM Test requirements [12] [13].

ID	Failure Modes of Volatile Memory	RAM Test SRS Requirements
001	Low Coverage (60%): Stuck-at for data, addresses and control interface, lines and logic.	A Test algorithm with low coverage shall be available
002	Medium Coverage (90%): d.c. fault model for data, addresses (includes address lines within same block and inability to write to cell) and control interface, lines and logic	A Test algorithm with medium coverage shall be available
003	Medium Coverage (90%): Soft error model for bit cells	-
004	High Coverage (99%): d.c. fault model for data, addresses (includes address lines within same block and inability to write to cell) and control interface, lines and logic	A Test algorithm with high coverage shall be available
005	High Coverage (99%): Soft error model for bit cells	

**Table 4.3: Mapping between Volatile Memory Failure Modes and RAM Test requirements**

### 4.2.2 Description

The RAM Test Driver is an AUTOSAR Basic Software Module which accesses the microcontroller RAM directly without intermediate software layers. It is located in the Abstraction Layer (MCAL).

The RAM Test driver performs a test of the physical health of the RAM cells, it is not intended to test the contents of the RAM. Furthermore, RAM used for registers is also tested.

Different algorithms exist to test RAM. They target different sets of fault models, achieve different coverages, result in different runtimes and are either destructive or non-destructive. Coverage also depends on the underlying physical RAM architecture.

An ECU safety analysis must be performed to determine which RAM Test diagnostic coverage rate (Low, Medium or High) is required. Appropriate RAM Test algorithms and further configuration parameters are then selected at compile time. At run time, the application software may choose between the compiled algorithms (and between further parameters).

<sup>2</sup>[ISO 26262-5, Annex D] Table D.1 Volatile Memory

The RAM Test driver supports synchronous test methods called "foreground test" and asynchronous tests called "background test". During the execution of a RAM test algorithm, no other software shall be allowed to modify the RAM area under test.

#### **4.2.3 Detection and Reaction**

During the execution of non-destructive tests, the RAM Test module saves the contents of the RAM area under test and restores the original contents thereafter.

RAM Test reports errors to the diagnostic event manager (DEM) as production errors.

#### **4.2.4 Limitations**

1. Transient faults are not covered by RAM Test.

RAM Test can be used to detect static hardware errors during power-up and at runtime. Transient faults and intermittent faults are not covered and cannot be reliably detected by RAM Test.

2. During the execution of a RAM test algorithm, no other software and hardware shall be allowed to modify the RAM area under test. The RAM Test module cannot ensure data consistency (e.g. during NMI, DMA transfers, multiple active cores in a Multicore system). Therefore the execution of RAM Test may be limited to the power-up/sleep/shutdown phase of a microcontroller.
3. Destructive tests cause corruption of contents in memory under test.

During the execution of destructive tests, the contents of RAM area under test are not saved by the RAM Test module.

#### **4.2.5 References to AUTOSAR Documents**

Source: Requirements on RAM Test, V2.0.1, R4.2 Rev 1

A Test algorithm with low coverage shall be available

A Test algorithm with medium coverage shall be available

A Test algorithm with high coverage shall be available

The RAM Test Module shall be usable to comply with requirements of the different ASIL levels of ISO 26262.

#### 4.2.6 References to ISO26262

The following references to the ISO26262 standard are related to the aspects of RAM Test.

<i>ID</i>	<i>ISO26262 Reference</i>
015	Part 11: [5.1.13.5] RAM Pattern test
016	Part 11: [5.1.13.7] RAM March test
012	Part 11: [Table 33] Volatile Memory
013	Part 5: [Table D.1] General semiconductor elements - Volatile Memory

**Table 4.4: ISO26262 RAM Test References**



## A Appendix

### A.1 Acronyms and abbreviations

Used acronyms and abbreviations not contained in the AUTOSAR glossary

Abbreviation / Acronym:	Description:
HARA	Hazard Analysis
HAZOP	Hazard & Operability Analysis
SEooC	Safety Element out of Context
HTM	Hardware Test Manager
HTMSS	Hardware Test Manager on Startup and Shutdown
ASIL	Automotive Safety Integrity Level
DMA	Direct Memory Access
EMC	Electromagnetic Compatibility
IOC	Inter-OS-Application Communicator
CRC	Cyclic Redundancy Check
TP	Transport Protocol
BIST	Built In Self Test
FTTI	Fault Tolerant Time Interval
MSTP	Microcontroller Specific Test Package

**Table A.1: Acronyms and abbreviations used in the scope of this Document**

## B Related Documentation

- [1] ISO 26262 (all parts) – Road vehicles – Functional Safety  
<https://www.iso.org>
- [2] Specification of ECU Configuration  
AUTOSAR\_CP\_TPS\_ECUConfiguration
- [3] Layered Software Architecture  
AUTOSAR\_CP\_EXP\_LayeredSoftwareArchitecture
- [4] Specification of Operating System  
AUTOSAR\_CP\_SWS\_OS
- [5] Explanation of Error Handling on Application Level  
AUTOSAR\_CP\_EXP\_ApplicationLevelErrorHandling
- [6] Specification of Watchdog Manager  
AUTOSAR\_CP\_SWS\_WatchdogManager
- [7] Specification of SW-C End-to-End Communication Protection Library  
AUTOSAR\_CP\_SWS\_E2ELibrary
- [8] Specification of Module E2E Transformer  
AUTOSAR\_CP\_SWS\_E2ETransformer
- [9] Specification of Synchronized Time-Base Manager  
AUTOSAR\_CP\_SWS\_SynchronizedTimeBaseManager
- [10] Requirements on Core Test  
AUTOSAR\_CP\_SRS\_CoreTest
- [11] Specification of Core Test  
AUTOSAR\_CP\_SWS\_CoreTest
- [12] Requirements on RAM Test  
AUTOSAR\_CP\_SRS\_RAMTest
- [13] Specification of RAM Test  
AUTOSAR\_CP\_SWS\_RAMTest