

Document Title	Specification of Software Cluster Connection module
Document Owner	AUTOSAR
Document Responsibility	AUTOSAR
Document Identification No	974

Document Status	published
Part of AUTOSAR Standard	Classic Platform
Part of Standard Release	R22-11

Document Change History			
Date	Release	Changed by	Description
2022-11-24	R22-11	AUTOSAR Release Management	Corrections and editorial changes of existing features
2021-11-25	R21-11	AUTOSAR Release Management	added support for <ul style="list-style-type: none"> • signal and SOME/IP based communication from Software Components located in an Application Software Cluster • connection to diagnostic services as Dem, FiM, Dcm. • Software Cluster Service Resources for connection of WdgM instances in different Software Clusters
2020-11-30	R20-11	AUTOSAR Release Management	Initial release

Disclaimer

This work (specification and/or software implementation) and the material contained in it, as released by AUTOSAR, is for the purpose of information only. AUTOSAR and the companies that have contributed to it shall not be liable for any use of the work.

The material contained in this work is protected by copyright and other types of intellectual property rights. The commercial exploitation of the material contained in this work requires a license to such intellectual property rights.

This work may be utilized or reproduced without any modification, in any form or by any means, for informational purposes only. For any other purpose, no part of the work may be utilized or reproduced, in any form or by any means, without permission in writing from the publisher.

The work has been developed for automotive applications only. It has neither been developed, nor tested for non-automotive applications.

The word AUTOSAR and the AUTOSAR logo are registered trademarks.

Contents

1	Introduction and functional overview	16
2	Acronyms and abbreviations	17
3	Related documentation	22
3.1	Input documents & related standards and norms	22
3.2	Related specification	23
4	Constraints and assumptions	24
4.1	Limitations	24
4.2	Applicability to car domains	24
5	Dependencies to other modules	25
5.1	Binary Manifest	25
5.1.1	Header File structure	25
5.2	Cross Cluster Communication	25
5.3	Proxy Modules	25
6	Requirements Tracing	26
7	Functional specification	44
7.1	Binary Manifest	44
7.1.1	Overview	44
7.1.2	Logical structure of a Binary Manifest	45
7.1.3	Mapping between Logical structure and Configuration structure	47
7.1.4	Implementation structure of a Binary Manifest	49
7.1.4.1	Implementation Overview	51
7.1.4.2	Multiple Notifier Sets Introduction	52
7.1.4.3	Binary Manifest Header	53
7.1.4.4	Interface Descriptor Table	55
7.1.4.5	Offered Interface Table	60
7.1.4.6	Subscribed Interface Table	60
7.1.4.7	Administrative Data	61
7.1.4.8	Memory Mapping	62
7.1.5	Connecting Software Clusters	65
7.1.5.1	Overview	65
7.1.5.2	Connecting Resources	65
7.1.5.3	Handling of the Substitution Software Cluster	66
7.1.5.4	Multiple Notifier Sets	67
7.1.5.5	Unconnected Resources	68
7.1.5.6	Disabling of the On-board Software Cluster Connection	69
7.1.5.7	Errors during software cluster connection	69
7.1.6	Software Cluster Binary Manifest Descriptor	70
7.1.7	Error Classification	71

7.1.7.1	Development Errors	71
7.1.7.2	Runtime Errors	71
7.1.7.3	Transient Faults	71
7.1.7.4	Production Errors	72
7.1.7.5	Extended Production Errors	72
7.2	Software Cluster Base Configuration Check	72
7.3	Cross Cluster Communication	73
7.3.1	Overview	73
7.3.2	General Requirements	74
7.3.2.1	Cross Software Cluster Communication Plug-In	74
7.3.2.2	Cross Cluster Communication and Binary Manifest	75
7.3.2.3	Cross Cluster Communication Base Socket	88
7.3.2.4	Cross Cluster Communication and McSupport Data	88
7.3.3	Sender Receiver Communication	90
7.3.3.1	Restrictions on VFB communication features	90
7.3.3.2	Data Concistency	91
7.3.3.3	Transmission	91
7.3.3.4	Reception	93
7.3.4	NvData communication	96
7.3.4.1	Restrictions on VFB communication features	96
7.3.5	Client Server Communication	97
7.3.5.1	General	97
7.3.5.2	Timeout	97
7.3.5.3	Scheduling of main functions	98
7.3.5.4	Buffering	100
7.3.5.5	Response to Request Mapping	101
7.3.5.6	Client Side	102
7.3.5.7	Server Side	103
7.3.6	Modes Communication	104
7.3.6.1	General principles	104
7.3.6.2	Software Cluster providing a mode	105
7.3.6.3	Host Software Cluster requiring a mode	110
7.3.6.4	Application Software Cluster requiring a mode	110
7.3.6.5	Initialization	112
7.3.7	Trigger Communication	113
7.3.7.1	General principles	113
7.3.7.2	Software Cluster providing a trigger	113
7.3.7.3	Host Software Cluster requiring a trigger	117
7.3.7.4	Application Software Cluster requiring a trigger	117
7.3.8	Parameter Communication	119
7.3.9	Error Classification	120
7.3.9.1	Development Errors	120
7.3.9.2	Runtime Errors	120
7.3.9.3	Transient Faults	120
7.3.9.4	Production Errors	120
7.3.9.5	Extended Production Errors	120

7.4	Proxy Modules	121
7.4.1	Overview	121
7.4.2	Abstract Proxy Module Pattern	123
7.4.2.1	General Proxy functionality	123
7.4.2.2	Partitions	124
7.4.2.3	Unconnected Service Resources	126
7.4.2.4	Ecu Configuration Principles	126
7.4.2.5	Proxy Modules and Binary Manifest	127
7.4.3	Specific Proxy Module Requirements	128
7.4.3.1	OS Proxy	128
7.4.3.2	NvM Proxy	140
7.4.3.3	Com Proxy	149
7.4.3.4	LdCom Proxy	164
7.4.3.5	Dcm Proxy	177
7.4.3.6	Dem Proxy	197
7.4.3.7	FiM Proxy	205
7.4.4	Error Classification	209
7.4.4.1	Development Errors	209
7.4.4.2	Runtime Errors	211
7.4.4.3	Transient Faults	211
7.4.4.4	Production Errors	212
7.4.4.5	Extended Production Errors	212
7.5	Standardized Service Resources	212
7.5.1	Software Cluster Base Configuration Check	213
7.5.2	Cross Cluster Communication	213
7.5.3	OS Proxy	214
7.5.4	NvM Proxy	216
7.5.5	Com Proxy	217
7.5.6	LdCom Proxy	217
7.5.7	Dcm Proxy	218
7.5.8	Dem Proxy	219
7.5.9	FiM Proxy	220
7.5.10	WdgM	221
7.6	Common Functions	221
7.6.1	Version Info	221
7.6.2	Error Classification	222
7.6.2.1	Development Errors	222
8	API specification	223
8.1	Imported types	223
8.2	Type definitions	223
8.2.1	Binary Manifest	223
8.2.1.1	SwCluC_BManif_SwClusterIdType	223
8.2.1.2	SwCluC_BManif_MachineIdType	224
8.2.1.3	SwCluC_BManif_ConCtrlType	224
8.2.1.4	SwCluC_BManif_ResourcePropertiesType	224

8.2.1.5	SwCluC_BManif_ResourceTypeIdType	225
8.2.1.6	SwCluC_BManif_GlobalResourceIdType	225
8.2.1.7	SwCluC_BManif_ResourceGuardValueType	225
8.2.1.8	SwCluC_BManif_TableIndexType	226
8.2.1.9	SwCluC_BManif_HandleIndexType	226
8.2.1.10	SwCluC_BManif_VoidFncPtrType	226
8.2.1.11	SwCluC_BManif_HandleType	227
8.2.1.12	SwCluC_BManif_HeaderType	227
8.2.2	Cross Cluster Communication	229
8.2.3	ProxyModules	229
8.3	Function definitions	230
8.3.1	BinaryManifest	230
8.3.1.1	API Principles	230
8.3.1.2	SwCluC_BManif_GetHandle	232
8.3.1.3	SwCluC_BManif_GetHandle	233
8.3.1.4	SwCluC_BManif_GetConSwClusterId	233
8.3.1.5	SwCluC_BManif_GetConSwClusterId	234
8.3.1.6	SwCluC_BManif_GetNoOfHandleSets	235
8.3.1.7	SwCluC_BManif_GetNoOfHandleSets	236
8.3.1.8	SwCluC_BManif_GetValidityMarker	236
8.3.1.9	SWCLUC_BMANIF_NO_OF_ENTRIES	237
8.3.1.10	SWCLUC_BMANIF_NO_OF_NOTIFIER_SETS	237
8.3.2	Cross Cluster Communication	237
8.3.2.1	SwCluC_Xcc_Init1	238
8.3.2.2	SwCluC_Xcc_Init2	238
8.3.3	Proxy Modules	239
8.3.3.1	SwCluC_OsProxy_Init	239
8.3.3.2	SwCluC_NvMProxy_Init	239
8.3.3.3	SwCluC_LdComProxy_Init	240
8.3.3.4	SwCluC_ComProxy_Init	240
8.3.3.5	SwCluC_DcmProxy_Init	241
8.3.3.6	SwCluC_DemProxy_Init	242
8.3.3.7	SwCluC_FiMProxy_Init	242
8.3.4	Common Functions	243
8.3.4.1	SwCluC_GetVersionInfo	243
8.4	Callback notifications	243
8.4.1	Binary Manifest	243
8.4.2	Cross Cluster Communication	243
8.4.3	Proxy Modules	243
8.5	Scheduled functions	252
8.5.1	Binary Manifest	252
8.5.2	Cross Cluster Communication Scheduled functions	252
8.5.2.1	SwCluC_Xcc_MainFunction	252
8.5.3	Proxy Modules Scheduled functions	253
8.6	Expected interfaces	253
8.6.1	Mandatory interfaces	253

8.6.1.1	Binary Manifest	253
8.6.1.2	Cross Cluster Communication	253
8.6.1.3	Proxy Modules	253
8.6.2	Optional interfaces	253
8.6.2.1	Binary Manifest	254
8.6.2.2	Cross Cluster Communication	254
8.6.2.3	Proxy Modules	254
8.6.3	Configurable interfaces	254
8.6.3.1	Binary Manifest	254
8.6.3.2	Cross Cluster Communication	254
8.6.3.3	Proxy Modules	254
8.7	Service Interfaces	254
8.7.1	Binary Manifest	254
8.7.2	Cross Cluster Communication	255
8.7.3	Proxy Modules	255
9	Sequence diagrams	256
10	Configuration specification	257
10.1	How to read this chapter	257
10.2	Containers and configuration parameters	257
10.2.1	Module Configuration	258
10.2.2	General configuration parameters	259
10.2.3	Software Cluster Definition	261
10.2.4	Software Cluster Base Configuration Check	265
10.2.5	Binary Manifest	267
10.2.5.1	Provide Resource Entry Group	270
10.2.5.2	Provided Resource Entry	272
10.2.5.3	Require Resource Entry Group	275
10.2.5.4	Require Resource Entry	277
10.2.5.5	Resource Type	279
10.2.6	Cross Cluster Communication	284
10.2.6.1	Cross Cluster Communication Base Socket	286
10.2.6.2	Cross Cluster Communication Rte Plug-in Props	288
10.2.6.3	Cross Cluster Communication Main Function	290
10.2.7	Proxy Modules	292
10.2.7.1	NvM Proxy	297
10.2.7.2	Os Proxy	305
10.2.7.3	Com Proxy	327
10.2.7.4	LdCom Proxy	340
10.2.7.5	Dcm Proxy	352
10.2.7.6	Dem Proxy	363
10.2.7.7	FiM Proxy	370
10.3	Published Information	376
A	Not applicable requirements	377

B	Referenced Meta Classes	378
C	Referenced ECUC Configuration Parameters	457
C.1	EcuC	457
C.1.1	EcucPartition	457
C.1.2	Pdu	459
C.1.3	EcucPduDedicatedPartition	462
C.2	RTE	463
C.2.1	RteEventToTaskMapping	463
C.2.2	RteInitializationRunnableBatch	470
C.3	Os	471
C.3.1	OsAlarm	471
C.3.2	OsApplication	472
C.3.3	OsCounter	476
C.3.4	OsEvent	479
C.3.5	OsResource	479
C.3.6	OsScheduleTable	481
C.3.7	OsScheduleTableExpiryPoint	482
C.3.8	OsSpinlock	483
C.3.9	OsTask	485
C.4	NvM	488
C.4.1	NvMBlockDescriptor	488
C.4.2	NvMInitBlockCallback	503
C.4.3	NvMSingleBlockCallback	503
C.5	Dcm	504
C.5.1	DcmDspDid	504
C.5.2	DcmDspDidInfo	507
C.5.3	DcmDspData	509
C.5.4	DcmDspDataInfo	518
C.5.5	DcmDspPidService01	519
C.5.6	DcmDspDidRead	521
C.5.7	DcmDspDidWrite	523
C.5.8	DcmDspDidControl	525
C.5.9	DcmDspRoutine	528
C.6	Dem	531
C.6.1	DemEventParameter	531
C.6.2	DemDataElementClass	539
C.7	FiM	540
C.7.1	FiMFID	540
C.8	Com	540
C.8.1	ComMainFunctionTx	540
C.8.2	ComMainFunctionRx	542
C.8.3	ComGroupSignal	543
C.8.4	ComIPdu	549
C.8.5	ComSignal	554
C.8.6	ComUserModule	563

C.8.7	ComUserUriDefSet	564
C.8.8	ComSignalGroup	564
C.9	LdCom	569
C.9.1	LdComConfig	570
C.9.2	LdComIPdu	570
C.9.3	LdComUserModule	572
C.9.4	LdComUserUriDefSet	573
C.10	WdgM	573
C.10.1	WdgMTransitionProxy	573
C.10.2	WdgMBaseSocket	574
D	Referenced C-API	576
D.1	RTE	576
D.1.1	Rte_Rips_DatalsUpdated	576
D.1.2	Rte_Rips_DRead	576
D.1.3	Rte_Rips_DatalsUpdated_EventActivation	577
D.1.4	Rte_Rips_Feedback	577
D.1.5	Rte_Rips_Invoke	578
D.1.6	Rte_Rips_InvocationHandler	578
D.1.7	Rte_Rips_Prm	579
D.1.8	Rte_Rips_Read	579
D.1.9	Rte_Rips_ReturnResult	579
D.1.10	Rte_Rips_Start	580
D.1.11	Rte_Rips_Stop	581
D.1.12	Rte_Rips_SchM_Deinit	581
D.1.13	Rte_Rips_SchM_Init	581
D.1.14	Rte_Rips_SwitchNotificationStatusType	582
D.1.15	Rte_Rips_Switch	582
D.1.16	Rte_Rips_DequeueModeSwitch	583
D.1.17	Rte_Rips_Trigger	583
D.1.18	Rte_Rips_Write	584
D.2	OS	584
D.3	NvM	585
D.3.1	NvM_CancelJobs	585
D.3.2	NvM_EraseNvBlock	586
D.3.3	NvM_GetDataIndex	586
D.3.4	NvM_GetErrorStatus	587
D.3.5	NvM_InvalidateNvBlock	587
D.3.6	NvM_ReadBlock	588
D.3.7	NvM_ReadPRAMBlock	588
D.3.8	NvM_RestoreBlockDefaults	589
D.3.9	NvM_RestorePRAMBlockDefaults	589
D.3.10	NvM_SetBlockLockStatus	590
D.3.11	NvM_SetBlockProtection	590
D.3.12	NvM_SetDataIndex	591
D.3.13	NvM_SetRamBlockStatus	591

D.3.14	NvM_WriteBlock	592
D.3.15	NvM_WritePRAMBlock	592
D.3.16	NvM_SingleBlockCallbackFunction	593
D.3.17	NvM_InitBlockCallbackFunction	593
D.3.18	NvM_ReadRamBlockFromNvm	593
D.3.19	NvM_WriteRamBlockToNvm	594
D.4	Com	594
D.4.1	Com_SendSignal	594
D.4.2	Com_SendDynSignal	595
D.4.3	Com_SendSignalGroup	595
D.4.4	Com_SendSignalGroupArray	596
D.4.5	Com_SendSignalWithMetaData	596
D.4.6	Com_SendDynSignalWithMetaData	597
D.4.7	Com_SendSignalGroupWithMetaData	598
D.4.8	Com_SendSignalGroupArrayWithMetaData	598
D.4.9	Com_ReceiveSignal	599
D.4.10	Com_ReceiveDynSignal	599
D.4.11	Com_ReceiveSignalGroup	600
D.4.12	Com_ReceiveSignalGroupArray	600
D.4.13	Com_ReceiveSignalWithMetaData	601
D.4.14	Com_ReceiveDynSignalWithMetaData	601
D.4.15	Com_ReceiveSignalGroupWithMetaData	602
D.4.16	Com_ReceiveSignalGroupArrayWithMetaData	602
D.4.17	Com_InvalidateSignal	603
D.4.18	Com_InvalidateSignalGroup	603
D.5	LdCom	604
D.5.1	LdCom_Transmit	604
D.6	Dcm	604
D.6.1	DataServices	604
D.6.1.1	ReadData	604
D.6.1.2	WriteData	605
D.6.1.3	ConditionCheckRead	606
D.6.1.4	ReadDataLength	607
D.6.1.5	GetScalingInformation	608
D.6.1.6	ReturnControlToECU	609
D.6.1.7	ResetToDefault	610
D.6.1.8	FreezeCurrentState	611
D.6.1.9	ShortTermAdjustment	613
D.6.2	RoutineServices	614
D.6.2.1	Xxx_Start Operation	614
D.6.2.2	Xxx_StartConfirmation Operation	615
D.6.2.3	Xxx_Stop Operation	615
D.6.2.4	Xxx_StopConfirmation Operation	616
D.6.2.5	Xxx_RequestResults Operation	617
D.6.2.6	Xxx_RequestResultsConfirmation Operation	617
D.6.3	ServiceRequestNotification	618

	D.6.3.1	Indication	618
	D.6.3.2	Confirmation	619
D.7	Dem		619
	D.7.1	Dem_ClearPrestoredFreezeFrame	619
	D.7.2	Dem_PrestoreFreezeFrame	620
	D.7.3	Dem_ResetEventDebounceStatus	620
	D.7.4	Dem_ResetEventStatus	621
	D.7.5	Dem_SetEventDisabled	621
	D.7.6	Dem_SetEventStatus	622
	D.7.7	Dem_GetDTCOfEvent	622
	D.7.8	Dem_GetDebouncingOfEvent	623
	D.7.9	Dem_GetEventAvailable	623
	D.7.10	Dem_GetEventExtendedDataRecordEx	624
	D.7.11	Dem_GetEventFreezeFrameDataEx	625
	D.7.12	Dem_GetEventUdsStatus	625
	D.7.13	Dem_GetFaultDetectionCounter	626
	D.7.14	Dem_GetMonitorStatus	626
	D.7.15	Dem_SetEventStatusWithMonitorData	627
	D.7.16	Dem_SetWIRStatus	627
	D.7.17	<Module>_DemGetFaultDetectionCounter<ForEvent>	628
	D.7.18	<Module>_DemInitMonitorFor<EventName>	628
	D.7.19	<Module>_DemTriggerOnMonitorStatus	629
	D.7.20	<Module>_DemClearEventAllowed<ForCondition>	629
	D.7.21	<Module>_DemTriggerOnEventData	630
	D.7.22	<Module>_DemTriggerOnEventUdsStatus	630
D.8	FiM		631
	D.8.1	FiM_GetFunctionPermission	631
	D.8.2	FiM_SetFunctionAvailable	631
E	Referenced Service Interfaces		632
E.1	Os		632
E.2	NvM		632
	E.2.1	NvM_BlockIdType	632
	E.2.2	NvM_BlockRequestType	632
	E.2.3	NvM_InitBlockRequestType	633
	E.2.4	NvM_RequestResultType	633
	E.2.5	NvMService	634
	E.2.6	NvMAdmin	638
	E.2.7	NvMNotifyJobFinished	639
	E.2.8	NvMNotifyInitBlock	639
	E.2.9	NvMMirror	640
	E.2.10	PS_{Block}	640
	E.2.11	PAdmin_{Block}	641
	E.2.12	PNJF_{Block}	641
	E.2.13	PNIB_{Block}	642
	E.2.14	PM_{Block}	642

E.3	Dcm	643
E.3.1	Implementation Data Types	643
E.3.1.1	Dcm_OpStatusType	643
E.3.1.2	Dcm_ConfirmationStatusType	643
E.3.1.3	Dcm_NegativeResponseCodeType	645
E.3.1.4	Dcm_DataElementType_{Data}Type	647
E.3.1.5	Dcm_DataElementType_{Data}ArrayType	648
E.3.1.6	Dcm_DataElementType_{Data}PrimitiveType	649
E.3.1.7	Dcm_DataArrayTypeUint8_{Data}Type	650
E.3.1.8	{DID}_Struct_DataType	651
E.3.1.9	Dcm_RangeArray_{Range}Type	651
E.3.1.10	Dcm_ScalingInfoArray_{Data}Type	651
E.3.1.11	Dcm_RequestDataOut_{Routine}_{Signal}PrimitiveType	652
E.3.1.12	Dcm_RequestDataIn_{Routine}_{Signal}PrimitiveType	652
E.3.1.13	Dcm_RequestDataOut_{Routine}_{Signal}Type	653
E.3.1.14	Dcm_RequestDataIn_{Routine}_{Signal}Type	654
E.3.1.15	Dcm_RequestDataOut_{Routine}_{Signal}ArrayType	654
E.3.1.16	Dcm_RequestDataIn_{Routine}_{Signal}ArrayType	655
E.3.1.17	Dcm_RequestFlexibleOutArrayData_{Routine}_{Signal}Type	656
E.3.1.18	Dcm_RequestFlexibleInArrayData_{Routine}_{Signal}Type	656
E.3.1.19	Dcm_StartDataIn_{Routine}_{Signal}PrimitiveType	657
E.3.1.20	Dcm_StartDataIn_{Routine}_{Signal}Type	658
E.3.1.21	Dcm_StartDataIn_{Routine}_{Signal}ArrayType	658
E.3.1.22	Dcm_StartDataOut_{Routine}_{Signal}PrimitiveType	659
E.3.1.23	Dcm_StartDataOut_{Routine}_{Signal}Type	660
E.3.1.24	Dcm_StartDataOut_{Routine}_{Signal}ArrayType	660
E.3.1.25	Dcm_StartFlexibleInArrayData_{Routine}_{Signal}Type	661
E.3.1.26	Dcm_StartFlexibleOutArrayData_{Routine}_{Signal}Type	661
E.3.1.27	Dcm_StopDataIn_{Routine}_{Signal}PrimitiveType	662
E.3.1.28	Dcm_StopDataIn_{Routine}_{Signal}Type	662
E.3.1.29	Dcm_StopDataIn_{Routine}_{Signal}ArrayType	663
E.3.1.30	Dcm_StopDataOut_{Routine}_{Signal}PrimitiveType	664
E.3.1.31	Dcm_StopDataOut_{Routine}_{Signal}Type	664
E.3.1.32	Dcm_StopDataOut_{Routine}_{Signal}ArrayType	665
E.3.1.33	Dcm_StopFlexibleInArrayData_{Routine}_{Signal}Type	666
E.3.1.34	Dcm_StopFlexibleOutArrayData_{Routine}_{Signal}Type	666
E.3.1.35	Dcm_KeyArray_{SecurityLevel}Type	666
E.3.1.36	Dcm_SeedArray_{SecurityLevel}Type	667
E.3.1.37	Dcm_SecurityAccessDataRecordArray_{SecurityLevel}Type	667

E.3.1.38	Dcm_RequestDataArrayType	667
E.3.1.39	Dcm_ControlMask_{DID}Type	668
E.3.1.40	Dcm_inputOutputControlParameterType	668
E.3.1.41	Dcm_IOOperationRequest_{DID}Type	669
E.3.1.42	Dcm_IOOperationResponseType	669
E.3.1.43	Dcm_ResponseDataArrayType	670
E.3.1.44	Dcm_ControlMask_{Data}ArrayType	670
E.3.1.45	Dcm_Cemr_{DID}Type	670
E.3.2	Sender-Receiver-Interfaces	671
E.3.2.1	DataServices_{DID}	671
E.3.2.2	DataServices_{Data}	671
E.3.2.3	IOControlRequest_{DID}	672
E.3.2.4	IOControlResponse_{DID}	672
E.3.3	NvDataInterface	673
E.3.3.1	DataServices_{DID}	673
E.3.4	Client-Server-Interfaces	673
E.3.4.1	DataServices_{Data}	673
E.3.4.2	RoutineServices_{RoutineName}	673
E.3.4.3	ServiceRequestNotification	687
E.3.5	Ports	689
E.3.5.1	DataServices_{DID} RPortProtoype	689
E.3.5.2	DataServices_{DID} PPortProtoype	690
E.3.5.3	DataServices_{DID} PRPortProtoype	690
E.3.5.4	DataServices_{Data} RPortProtoype	691
E.3.5.5	DataServices_{Data} RPortProtoype	691
E.3.5.6	DataServices_{Data} PPortProtoype	691
E.3.5.7	DataServices_{Data} PRPortProtoype	691
E.3.5.8	IOControlRequest_{DID}	692
E.3.5.9	IOControlResponse_{DID}	692
E.3.5.10	ServiceRequestManufacturerNotification_{Name}	692
E.3.5.11	ServiceRequestSupplierNotification_{Name}	693
E.3.5.12	RoutineServices_{RoutineName}	693
E.4	Dem	693
E.4.1	Implementation Data Types	693
E.4.1.1	Dem_DebouncingStateType	693
E.4.1.2	Dem_DTCTOriginType	694
E.4.1.3	Dem_EventIdType	694
E.4.1.4	Dem_EventStatusType	694
E.4.1.5	Dem_DebounceResetStatusType	695
E.4.1.6	Dem_DTCTFormatType	695
E.4.1.7	Dem_InitMonitorReasonType	696
E.4.1.8	Dem_MaxDataValueType	696
E.4.1.9	Dem_MonitorDataType	696
E.4.1.10	Dem_MonitorStatusType	697
E.4.1.11	Dem_UdsStatusByteType	697
E.4.2	Client-Server-Interfaces	698

E.4.2.1	CallbackClearEventAllowed	698
E.4.2.2	CallbackEventDataChanged	698
E.4.2.3	CallbackEventUdsStatusChanged	699
E.4.2.4	CallbackGetFaultDetectCounter	699
E.4.2.5	CallbackInitMonitorForEvent	700
E.4.2.6	CallbackMonitorStatusChange	700
E.4.2.7	DiagnosticInfo	700
E.4.2.8	DiagnosticMonitor	704
E.4.2.9	DiagnosticMonitor_MonitorData	705
E.4.2.10	EventStatus	706
E.4.3	Ports	707
E.4.3.1	Event	707
E.4.3.2	DiagnosticMonitor_MonitorData	707
E.4.3.3	EventStatus	707
E.4.3.4	EventInfo	707
E.4.3.5	CBClrEvt	708
E.4.3.6	CBDataEvt	708
E.4.3.7	CBFaultDetectCtr	708
E.4.3.8	CBInitEvt	708
E.4.3.9	CBEventUdsStatusChanged	709
E.4.3.10	CBMonitorStatusChanged	709
E.5	FiM	709
E.5.1	Implementation Data Types	709
E.5.1.1	FiM_FunctionIdType	709
E.5.2	Client-Server-Interfaces	710
E.5.2.1	FiM_FunctionInhibition	710
E.5.2.2	FiM_ControlFunctionAvailable	710
E.5.3	Ports	711
E.5.3.1	FiM_FunctionInhibition	711
E.5.3.2	FiM_ControlFunctionAvailable	711
F	Changes History	712
F.1	Changes in R20-11 compared to R19-11	712
F.1.1	Added Traceables in R20-11	712
F.1.2	Changed Traceables in R20-11	714
F.1.3	Deleted Traceables in R20-11	714
F.2	Changes in R21-11 compared to R20-11	715
F.2.1	Added Traceables in R21-11	715
F.2.2	Changed Traceables in R21-11	717
F.2.3	Deleted Traceables in R21-11	717
F.3	Changes in R22-11 compared to R21-11	718
F.3.1	Added Traceables in R22-11	718
F.3.2	Changed Traceables in R22-11	718
F.3.3	Deleted Traceables in R22-11	720

Known Limitations

- Not all VFB communication features are supported
- The Proxy Modules are not specified for all BSW Services
- No run-time separation is defined

Additional limitations are described in document [\[1\]](#)

1 Introduction and functional overview

This specification describes the functionality, API and the configuration for the AUTOSAR Basic Software module [Software Cluster Connection](#).

2 Acronyms and abbreviations

The glossary below includes acronyms and abbreviations relevant to Requirements on Software Cluster Connection that are not included in the AUTOSAR Glossary [2].

Abbreviation / Acronym:	Description:
SwCluC	Software Cluster Connection

Table 2.1: Acronyms and Abbreviations

Terms:	Description:
Software Cluster	A Software Cluster groups all AUTOSAR artifacts that are relevant to deploy software on a machine. The full definition is given in document [2]
Software Cluster Connection	The Software Cluster Connection is the BSW module that provides the features to <ul style="list-style-type: none"> connect the Binary Objects deployed on the same machine substitute not locally-available BSW modules in an Application Software Cluster, whose interfaces are required for the integrated SW, by so called Proxy Modules. implement the VFB communication features between Software Clusters together with RTE by means of an RTE Implementation Plug-In
machine	A machine consists of a set of computing resources - such as microcontroller cores, memory or peripheral (e.g. communication) devices - and has the ability to execute software applications. The representation of a machine in the AUTOSAR Classic Platform could be done with an EcuInstance , but note that this semantic is currently in clarification. Further information is given in document [2].
binary-identical	Bit for Bit identical
Binary Object	A set of files, which contains the binary executable code and data. This binary executable code and data will not be modified again, before programming it on the target ECU.
Binary Manifest	The Binary Manifest is the well-defined interface of the Software Cluster's Binary Object , providing the meta information of a resources and information - so called handles - to access such a resource.
Application Software Cluster	A Software Cluster that mainly contains software components, and only selected BSW modules (e.g. a Service module, transformers, e.t.c.)
Host Software Cluster	The single Software Cluster that contains the major part of the BSW, and especially the micro controller dependent lower layer BSW Modules, e.g. OS and MCAL.
Substitution Software Cluster	The single Software Cluster that can override the provided resources of other Software Clusters for bug fixing purpose.

Terms:	Description:
Proxy Module	A Proxy Module substitutes a BSW module in an Application Software Cluster . A Proxy module itself is split into High Proxy Module and Low Proxy Module . The High Proxy Module provides dedicated interfaces for modules in higher layers or same layer, and the functionality to connect them via the Binary Manifest to the Low Proxy Module in the Host Software Cluster .
High Proxy Module	The part of the Proxy Module residing in an Application Software Cluster .
Low Proxy Module	The part of the Proxy Module residing in the Host Software Cluster .
Os High Proxy	A type of Proxy Module implementing Os APIs in the Application Software Cluster .
Os Low Proxy	A type of proxy Module implementing an Os abstraction in the Host Software Cluster .
NvM High Proxy	A type of Proxy Module substituting the NVRAM Manager in the Application Software Cluster .
NvM Low Proxy	A type of Proxy Module connecting the NvM High Proxys module to the NVRAM Manager in the Host Software Cluster .
LdCom High Proxy	A type of Proxy Module implementing default LdCom (Callback) APIs in the Application Software Cluster .
LdCom Low Proxy	A type of proxy Module connecting LdCom High Proxys module to the LdCom in the Host Software Cluster .
Com High Proxy	A type of Proxy Module implementing default Com (Callback) APIs in the Application Software Cluster .
Com Low Proxy	A type of proxy Module connecting Com High Proxys module to the Com in the Host Software Cluster .
Dcm High Proxy	A type of Proxy Module substituting the Dcm in the Application Software Cluster .
Dcm Low Proxy	A type of proxy Module connecting Dcm High Proxys module to the Dcm in the Host Software Cluster .
Dem High Proxy	A type of Proxy Module substituting the Dem in the Application Software Cluster .
Dem Low Proxy	A type of proxy Module connecting Dem High Proxys module to the Dem in the Host Software Cluster .
FiM High Proxy	A type of Proxy Module substituting the FiM in the Application Software Cluster .
FiM Low Proxy	A type of proxy Module connecting FiM High Proxys module to the FiM in the Host Software Cluster .
Cross Cluster Communication	The Cross Cluster Communication implements the VFB communication between Software Clusters .
RTE Implementation Plug-In	A RTE Implementation Plug-In is a part of the overall RTE implementation, which is not provided by the RTE Generator, but from an additional source (e.g. a Plug-In Generator or a manually implemented source code).
RTE Implementation Plug-In Service	A RTE Implementation Plug-In Service is a single entry point into the RTE Implementation Plug-In implementing a low level service for the RTE. For instance access to a specific buffer.
Local Software Cluster Communication Plug-In	A Local Software Cluster Communication Plug-In is an RTE Implementation Plug-In , which handles the communication locally inside a Software Cluster . This includes the Transformer handling, if a DataMapping exist for the according Communication Graph

Terms:	Description:
Cross Software Cluster Communication Plug-In	A Cross Software Cluster Communication Plug-In is an RTE Implementation Plug-In that handles the communication towards other Software Clusters . This includes the Transformer handling, if intra ECU transformation is configured.
Communication Graph	The sum of all AbstractAccessPoints to elements of PortInterfaces , instantiated in PortPrototypes which are connected to each other; or the sum of all accesses from BswModuleEntitys to interface elements in a BswModuleDescriptions connected to each other.
Data Communication Graph	The sum of all VariableAccesses to VariableDataPrototypes instantiated in PortPrototypes , which are connected to each other; or the sum of all VariableAccesses to VariableDataPrototypes in the InternalBehavior ; or the sum of all BswVariableAccesses to VariableDataPrototypes in BswModuleDescriptions connected to each other.
Parameter Communication Graph	The sum of all ParameterAccesses to ParameterDataPrototypes instantiated in PortPrototypes , which are connected to each other; or the sum of all ParameterAccesses to ParameterDataPrototypes in the InternalBehavior .
Client Server Communication Graph	The sum of all ServerCallPoints to operations instantiated in PortPrototypes , which are connected to each other, including the associated server runnable .
client	A client is defined as one ClientServerOperation in one RPortPrototype of one Software Component instance. For the definition of the client neither the number of ServerCallPoints nor RunnableEntity accesses to the ServerCallPoint are relevant. A Software Component instance can appear as several clients to the same server if it defines ServerCallPoints for several PortPrototypes of the same PortInterface 's ClientServerOperation .
server	A server is defined as one RunnableEntity which is the target of an OperationInvokedEvent . Call serialization is on activation of RunnableEntity .
server runnable	A server that is triggered by an OperationInvokedEvent . It has a mixed behavior between a runnable and a function call. In certain situations, RTE can implement the client server communication as a simple function call.
Trigger Communication Graph	The sum of all ExternalTriggeringPoints for triggers instantiated in PortPrototypes , which are connected to each other, including the associated triggered runnable .
Mode Communication Graph	The sum of all ModeAccessPoints and ModeSwitchPoints to ModeDeclarationGroupPrototypes instantiated in PortPrototypes , which are connected to each other; or the sum of all managedModeGroups and accessedModeGroups to ModeDeclarationGroupPrototypes in BswModuleDescriptions connected to each other.
mode manager	Entering and leaving modes is initiated by a <i>mode manager</i> . A <i>mode manager</i> is either a software component that provides a p-port typed by a ModeSwitchInterface , or a BSW module that defines in its BswModuleDescription a ModeDeclarationGroupPrototype in the role providedModeGroup .

Terms:	Description:
mode switch notification	The communication of a mode switch from the <code>mode manager</code> to the <code>mode user</code> , using either the <code>ModeSwitchInterface</code> or <code>providedModeGroup</code> and <code>requiredModeGroup ModeDeclarationGroupPrototypes</code> .
mode switch port	The port for receiving (or sending) a mode switch notification. For this purpose, a <code>mode switch port</code> is typed by a <code>ModeSwitchInterface</code> .
mode user	An <i>AUTOSAR SW-C</i> or <i>AUTOSAR Basic Software Module</i> that depends on modes, is called a mode user. The dependency can occur through a <code>SwcModeSwitchEvent/BswModeSwitchEvent</code> , a <code>ModeAccessPoint</code> for a provided/required <code>mode switch port</code> , or a <code>accessedModeGroup</code> for a <code>providedModeGroup/requiredModeGroup ModeDeclarationGroupPrototype</code> .
on-entry ExecutableEntity	A <code>RunnableEntity</code> that is triggered by a <code>SwcModeSwitchEvent</code> with <code>ModeActivationKind</code> 'entry'; or a <code>BswSchedulableEntity</code> that is triggered by a <code>BswModeSwitchEvent</code> with <code>ModeActivationKind</code> 'entry'.
on-exit ExecutableEntity	A <code>RunnableEntity</code> that is triggered by a <code>SwcModeSwitchEvent</code> with <code>ModeActivationKind</code> 'exit'; or a <code>BswSchedulableEntity</code> that is triggered by a <code>BswModeSwitchEvent</code> with <code>ModeActivationKind</code> 'exit'.
on-transition ExecutableEntity	A <code>RunnableEntity</code> that is triggered by a <code>SwcModeSwitchEvent</code> with <code>ModeActivationKind</code> 'transition'; or a <code>BswSchedulableEntity</code> that is triggered by a <code>BswModeSwitchEvent</code> with <code>ModeActivationKind</code> 'transition'.
trigger port	A <code>PortPrototype</code> , which is typed by an <code>TriggerInterface</code>
trigger sink	A <i>trigger sink</i> relies on the activation of <code>RunnableEntity</code> or a <code>BswSchedulableEntity</code> , if a particular <code>Trigger</code> is raised. A <i>trigger sink</i> has a dedicated <code>require trigger port(s)</code> and / or <code>requiredTrigger Trigger(s)</code> to communicate to the <code>trigger source(s)</code> .
trigger source	A <i>trigger source</i> administrates the particular <code>Trigger</code> , and informs the RTE or <i>Basic Software Scheduler</i> if the <code>Trigger</code> is raised. A <i>trigger source</i> has dedicated <code>provide trigger port(s)</code> and / or <code>releasedTrigger Trigger(s)</code> to communicate to the <code>trigger sink(s)</code> .
triggered BswSchedulableEntity	A <code>BswSchedulableEntity</code> that is triggered at least by one <code>BswExternalTriggerOccurredEvent</code> or <code>BswInternalTriggerOccurredEvent</code> . In particular cases, the <i>Trigger Event Communication</i> or the <i>Inter Basic Software Schedulable Entity Triggering</i> is implemented by the <i>Basic Software Scheduler</i> as a direct or trusted function call of the <code>triggered ExecutableEntity</code> , by the triggering <code>ExecutableEntity</code> .
triggered ExecutableEntity	A <code>RunnableEntity</code> that is triggered by at least one <code>ExternalTriggerOccurredEvent / InternalTriggerOccurredEvent</code> ; or a <code>BswSchedulableEntity</code> that is triggered by at least one <code>BswExternalTriggerOccurredEvent / BswInternalTriggerOccurredEvent</code> . In particular cases, the <i>Trigger Event Communication</i> or the <i>Inter Runnable Triggering</i> is implemented by RTE or <i>Basic Software Scheduler</i> as a direct or trusted function call of the <code>triggered ExecutableEntity</code> , by the triggering <code>ExecutableEntity</code> .

Terms:	Description:
triggered runnable	A RunnableEntity that is triggered at least by one ExternalTriggerOccurredEvent or InternalTriggerOccurredEvent . In particular cases, the Trigger Event Communication or the <i>Inter Runnable Triggering</i> is implemented by RTE as a direct or trusted function call of the <i>triggered runnable</i> , by the triggering runnable.

Table 2.2: Terms

3 Related documentation

3.1 Input documents & related standards and norms

- [1] Explanation of CP Software Cluster Design And Integration Guideline
AUTOSAR_EXP_CPSwClusterDesignAndIntegrationGuideline
- [2] Glossary
AUTOSAR_TR_Glossary
- [3] General Specification of Basic Software Modules
AUTOSAR_SWS_BSWGeneral
- [4] Specification of RTE Software
AUTOSAR_SWS_RTE
- [5] Specification of Operating System
AUTOSAR_SWS_OS
- [6] Specification of NVRAM Manager
AUTOSAR_SWS_NVRAMManager
- [7] Specification of Communication Stack Types
AUTOSAR_SWS_CommunicationStackTypes
- [8] Specification of Large Data COM
AUTOSAR_SWS_LargeDataCOM
- [9] Specification of Communication
AUTOSAR_SWS_COM
- [10] Specification of Diagnostic Communication Manager
AUTOSAR_SWS_DiagnosticCommunicationManager
- [11] Specification of Diagnostic Event Manager
AUTOSAR_SWS_DiagnosticEventManager
- [12] Specification of Function Inhibition Manager
AUTOSAR_SWS_FunctionInhibitionManager
- [13] Requirements on Software Cluster Connection module
AUTOSAR_SRS_SoftwareClusterConnection
- [14] General Requirements on Basic Software Modules
AUTOSAR_SRS_BSWGeneral
- [15] System Template
AUTOSAR_TPS_SystemTemplate
- [16] Specification of CRC Routines
AUTOSAR_SWS_CRCLibrary
- [17] Specification of Memory Mapping

AUTOSAR_SWS_MemoryMapping

[18] Specification of ECU Configuration
AUTOSAR_TPS_ECUConfiguration

[19] Software Component Template
AUTOSAR_TPS_SoftwareComponentTemplate

[20] Specification of Watchdog Manager
AUTOSAR_SWS_WatchdogManager

[21] Specification of Platform Types
AUTOSAR_SWS_PlatformTypes

[22] Specification of Standard Types
AUTOSAR_SWS_StandardTypes

[23] ISO 17356-3: Road vehicles – Open interface for embedded automotive applications – Part 3: OSEK/VDX Operating System (OS)

3.2 Related specification

AUTOSAR provides a General Specification on Basic Software modules [3, SWS BSW General], which is also valid for [Software Cluster Connection](#).

Thus, the specification SWS BSW General shall be considered as additional and required specification for [Software Cluster Connection](#).

4 Constraints and assumptions

4.1 Limitations

The specification currently supports a limited number of BSW modules. Furthermore, for the supported BSW modules, the functionality and APIs available for [Application Software Clusters](#) is only subset of the overall functionality. In addition, the available VFB communication features are restricted.

4.2 Applicability to car domains

The specification focus on larger ECUs centralizing software functionality - so called domain or zone controllers. It assumes that the software components which are mapped to different [Software Clusters](#) are rather loosely coupled w.r.t. to interfaces and time domain. The software components supposed to implement mainly control loop software - usually time driven but may also react on limited numbers of sporadic events. Further information can be found in document [1].

5 Dependencies to other modules

5.1 Binary Manifest

5.1.1 Header File structure

[SWS_SwCluC_00013]{DRAFT} [The [Binary Manifest](#) of the [Software Cluster Connection](#) shall provide the header file `SwCluC_BManif.h`.

]()

[SWS_SwCluC_00014]{DRAFT} [The header file `SwCluC_BManif.h` shall include all header files configured in [SwCluCBManifHeaderIncludes](#) in the containers [SwCluCBManifProvideResourceEntryGroup](#) and [SwCluCBManifRequireResourceEntryGroup](#).]()

5.2 Cross Cluster Communication

The [Cross Cluster Communication](#) of the [Software Cluster Connection](#) depends on the RTE [4].

5.3 Proxy Modules

The `SwCluC` module has following dependencies for its sub-functionalities in the [Proxy Modules](#):

Each [Low Proxy Module](#) depends on its specific BSW module

- [Os Low Proxy](#) depends on OS [5]
- [NvM Low Proxy](#) depends on NvM [6]
- [LdCom High Proxy](#) depends on [Communication Stack Types](#) [7]
- [LdCom Low Proxy](#) depends on [LdCom](#) [8] and [Communication Stack Types](#) [7]
- [Com Low Proxy](#) depends on [Com](#) [9]
- [Dcm Low Proxy](#) depends on [Dcm](#) [10]
- [Dem Low Proxy](#) depends on [Dem](#) [11]
- [FiM Low Proxy](#) depends on [FiM](#) [12]

6 Requirements Tracing

The following tables reference the requirements specified in [13], SRS_SoftwareClusterConnection and [14], SRS_BSWGeneral and links to the fulfillment of these. Please note that if column “Satisfied by” is empty for a specific requirement this means that this requirement is not fulfilled by this document.

Requirement	Description	Satisfied by
[SRS_BSW_00003]	All software modules shall provide version and identification information	[SWS_SwCluC_NA_00999]
[SRS_BSW_00004]	All Basic SW Modules shall perform a pre-processor check of the versions of all imported include files	[SWS_SwCluC_NA_00999]
[SRS_BSW_00005]	Modules of the μ C Abstraction Layer (MCAL) may not have hard coded horizontal interfaces	[SWS_SwCluC_NA_00999]
[SRS_BSW_00006]	The source code of software modules above the μ C Abstraction Layer (MCAL) shall not be processor and compiler dependent.	[SWS_SwCluC_NA_00999]
[SRS_BSW_00007]	All Basic SW Modules written in C language shall conform to the MISRA C 2012 Standard.	[SWS_SwCluC_NA_00999]
[SRS_BSW_00009]	All Basic SW Modules shall be documented according to a common standard.	[SWS_SwCluC_NA_00999]
[SRS_BSW_00010]	The memory consumption of all Basic SW Modules shall be documented for a defined configuration for all supported platforms.	[SWS_SwCluC_NA_00999]
[SRS_BSW_00101]	The Basic Software Module shall be able to initialize variables and hardware in a separate initialization function	[SWS_SwCluC_11000] [SWS_SwCluC_11001] [SWS_SwCluC_12000] [SWS_SwCluC_12100] [SWS_SwCluC_12200] [SWS_SwCluC_12300] [SWS_SwCluC_12400] [SWS_SwCluC_13000] [SWS_SwCluC_13001]
[SRS_BSW_00159]	All modules of the AUTOSAR Basic Software shall support a tool based configuration	[SWS_SwCluC_NA_00999]





Requirement	Description	Satisfied by
[SRS_BSW_00160]	Configuration files of AUTOSAR Basic SW module shall be readable for human beings	[SWS_SwCluC_NA_00999]
[SRS_BSW_00161]	The AUTOSAR Basic Software shall provide a microcontroller abstraction layer which provides a standardized interface to higher software layers	[SWS_SwCluC_NA_00999]
[SRS_BSW_00162]	The AUTOSAR Basic Software shall provide a hardware abstraction layer	[SWS_SwCluC_NA_00999]
[SRS_BSW_00164]	The Implementation of interrupt service routines shall be done by the Operating System, complex drivers or modules	[SWS_SwCluC_NA_00999]
[SRS_BSW_00168]	SW components shall be tested by a function defined in a common API in the Basis-SW	[SWS_SwCluC_NA_00999]
[SRS_BSW_00170]	The AUTOSAR SW Components shall provide information about their dependency from faults, signal qualities, driver demands	[SWS_SwCluC_NA_00999]
[SRS_BSW_00171]	Optional functionality of a Basic-SW component that is not required in the ECU shall be configurable at pre-compile-time	[SWS_SwCluC_NA_00999]
[SRS_BSW_00172]	The scheduling strategy that is built inside the Basic Software Modules shall be compatible with the strategy used in the system	[SWS_SwCluC_03170] [SWS_SwCluC_03173] [SWS_SwCluC_91002]
[SRS_BSW_00300]	All AUTOSAR Basic Software Modules shall be identified by an unambiguous name	[SWS_SwCluC_NA_00999]
[SRS_BSW_00301]	All AUTOSAR Basic Software Modules shall only import the necessary information	[SWS_SwCluC_NA_00999]
[SRS_BSW_00302]	All AUTOSAR Basic Software Modules shall only export information needed by other modules	[SWS_SwCluC_NA_00999]





Requirement	Description	Satisfied by
[SRS_BSW_00304]	All AUTOSAR Basic Software Modules shall use only AUTOSAR data types instead of native C data types	[SWS_SwCluC_NA_00999]
[SRS_BSW_00306]	AUTOSAR Basic Software Modules shall be compiler and platform independent	[SWS_SwCluC_NA_00999]
[SRS_BSW_00307]	Global variables naming convention	[SWS_SwCluC_NA_00999]
[SRS_BSW_00308]	AUTOSAR Basic Software Modules shall not define global data in their header files, but in the C file	[SWS_SwCluC_NA_00999]
[SRS_BSW_00309]	All AUTOSAR Basic Software Modules shall indicate all global data with read-only purposes by explicitly assigning the const keyword	[SWS_SwCluC_NA_00999]
[SRS_BSW_00310]	API naming convention	[SWS_SwCluC_10000] [SWS_SwCluC_10001] [SWS_SwCluC_10002] [SWS_SwCluC_10003] [SWS_SwCluC_10004] [SWS_SwCluC_10005] [SWS_SwCluC_10006] [SWS_SwCluC_10007] [SWS_SwCluC_10008] [SWS_SwCluC_10011] [SWS_SwCluC_10020] [SWS_SwCluC_10021] [SWS_SwCluC_10022] [SWS_SwCluC_10023] [SWS_SwCluC_10032] [SWS_SwCluC_10033] [SWS_SwCluC_10034] [SWS_SwCluC_11000] [SWS_SwCluC_11001] [SWS_SwCluC_12000] [SWS_SwCluC_12100] [SWS_SwCluC_12200] [SWS_SwCluC_12300] [SWS_SwCluC_12400] [SWS_SwCluC_13000] [SWS_SwCluC_13001]
[SRS_BSW_00312]	Shared code shall be reentrant	[SWS_SwCluC_NA_00999]
[SRS_BSW_00314]	All internal driver modules shall separate the interrupt frame definition from the service routine	[SWS_SwCluC_NA_00999]
[SRS_BSW_00318]	Each AUTOSAR Basic Software Module file shall provide version numbers in the header file	[SWS_SwCluC_NA_00999]
[SRS_BSW_00321]	The version numbers of AUTOSAR Basic Software Modules shall be enumerated according specific rules	[SWS_SwCluC_NA_00999]
[SRS_BSW_00323]	All AUTOSAR Basic Software Modules shall check passed API parameters for validity	[SWS_SwCluC_02137] [SWS_SwCluC_02138] [SWS_SwCluC_02139] [SWS_SwCluC_02533] [SWS_SwCluC_02534] [SWS_SwCluC_02636] [SWS_SwCluC_02637] [SWS_SwCluC_02638] [SWS_SwCluC_02751] [SWS_SwCluC_03217] [SWS_SwCluC_03218] [SWS_SwCluC_09000]
[SRS_BSW_00325]	The runtime of interrupt service routines and functions that are running in interrupt context shall be kept short	[SWS_SwCluC_NA_00999]





Requirement	Description	Satisfied by
[SRS_BSW_00327]	Error values naming convention	[SWS_SwCluC_02140] [SWS_SwCluC_02426] [SWS_SwCluC_02545] [SWS_SwCluC_02650] [SWS_SwCluC_02750] [SWS_SwCluC_03216] [SWS_SwCluC_09001]
[SRS_BSW_00328]	All AUTOSAR Basic Software Modules shall avoid the duplication of code	[SWS_SwCluC_NA_00999]
[SRS_BSW_00330]	It shall be allowed to use macros instead of functions where source code is used and runtime is critical	[SWS_SwCluC_NA_00999]
[SRS_BSW_00331]	All Basic Software Modules shall strictly separate error and status information	[SWS_SwCluC_NA_00999]
[SRS_BSW_00335]	Status values naming convention	[SWS_SwCluC_NA_00999]
[SRS_BSW_00336]	Basic SW module shall be able to shutdown	[SWS_SwCluC_NA_00999]
[SRS_BSW_00337]	Classification of development errors	[SWS_SwCluC_02140] [SWS_SwCluC_02426] [SWS_SwCluC_02545] [SWS_SwCluC_02650] [SWS_SwCluC_02750] [SWS_SwCluC_03216] [SWS_SwCluC_09001]
[SRS_BSW_00339]	Reporting of production relevant error status	[SWS_SwCluC_NA_00999]
[SRS_BSW_00341]	Module documentation shall contains all needed informations	[SWS_SwCluC_NA_00999]
[SRS_BSW_00342]	It shall be possible to create an AUTOSAR ECU out of modules provided as source code and modules provided as object code, even mixed	[SWS_SwCluC_NA_00999]
[SRS_BSW_00343]	The unit of time for specification and configuration of Basic SW modules shall be preferably in physical time unit	[SWS_SwCluC_NA_00999]
[SRS_BSW_00344]	BSW Modules shall support link-time configuration	[SWS_SwCluC_NA_00999]
[SRS_BSW_00345]	BSW Modules shall support pre-compile configuration	[SWS_SwCluC_NA_00999]
[SRS_BSW_00346]	All AUTOSAR Basic Software Modules shall provide at least a basic set of module files	[SWS_SwCluC_NA_00999]
[SRS_BSW_00347]	A Naming separation of different instances of BSW drivers shall be in place	[SWS_SwCluC_NA_00999]





Requirement	Description	Satisfied by
[SRS_BSW_00348]	All AUTOSAR standard types and constants shall be placed and organized in a standard type header file	[SWS_SwCluC_NA_00999]
[SRS_BSW_00350]	All AUTOSAR Basic Software Modules shall allow the enabling/disabling of detection and reporting of development errors.	[SWS_SwCluC_02137] [SWS_SwCluC_02138] [SWS_SwCluC_02139] [SWS_SwCluC_02533] [SWS_SwCluC_02534] [SWS_SwCluC_02636] [SWS_SwCluC_02637] [SWS_SwCluC_02638] [SWS_SwCluC_02751] [SWS_SwCluC_03217] [SWS_SwCluC_03218]
[SRS_BSW_00351]	Encapsulation of compiler specific methods to map objects	[SWS_SwCluC_NA_00999]
[SRS_BSW_00353]	All integer type definitions of target and compiler specific scope shall be placed and organized in a single type header	[SWS_SwCluC_NA_00999]
[SRS_BSW_00357]	For success/failure of an API call a standard return type shall be defined	[SWS_SwCluC_NA_00999]
[SRS_BSW_00358]	The return type of init() functions implemented by AUTOSAR Basic Software Modules shall be void	[SWS_SwCluC_11000] [SWS_SwCluC_11001] [SWS_SwCluC_12000] [SWS_SwCluC_12100] [SWS_SwCluC_12200] [SWS_SwCluC_12300] [SWS_SwCluC_12400] [SWS_SwCluC_13000] [SWS_SwCluC_13001]
[SRS_BSW_00359]	All AUTOSAR Basic Software Modules callback functions shall avoid return types other than void if possible	[SWS_SwCluC_NA_00999]
[SRS_BSW_00360]	AUTOSAR Basic Software Modules callback functions are allowed to have parameters	[SWS_SwCluC_NA_00999]
[SRS_BSW_00369]	All AUTOSAR Basic Software Modules shall not return specific development error codes via the API	[SWS_SwCluC_02137] [SWS_SwCluC_02138] [SWS_SwCluC_02139] [SWS_SwCluC_02533] [SWS_SwCluC_02534] [SWS_SwCluC_02636] [SWS_SwCluC_02637] [SWS_SwCluC_02638] [SWS_SwCluC_02751] [SWS_SwCluC_03217] [SWS_SwCluC_03218] [SWS_SwCluC_09000]
[SRS_BSW_00373]	The main processing function of each AUTOSAR Basic Software Module shall be named according the defined convention	[SWS_SwCluC_09000] [SWS_SwCluC_91001] [SWS_SwCluC_91002] [SWS_SwCluC_NA_00999]
[SRS_BSW_00374]	All Basic Software Modules shall provide a readable module vendor identification	[SWS_SwCluC_NA_00999]
[SRS_BSW_00375]	Basic Software Modules shall report wake-up reasons	[SWS_SwCluC_NA_00999]





Requirement	Description	Satisfied by
[SRS_BSW_00377]	A Basic Software Module can return a module specific types	[SWS_SwCluC_NA_00999]
[SRS_BSW_00378]	AUTOSAR shall provide a boolean type	[SWS_SwCluC_NA_00999]
[SRS_BSW_00379]	All software modules shall provide a module identifier in the header file and in the module XML description file.	[SWS_SwCluC_NA_00999]
[SRS_BSW_00380]	Configuration parameters being stored in memory shall be placed into separate c-files	[SWS_SwCluC_NA_00999]
[SRS_BSW_00383]	The Basic Software Module specifications shall specify which other configuration files from other modules they use at least in the description	[SWS_SwCluC_NA_00999]
[SRS_BSW_00384]	The Basic Software Module specifications shall specify at least in the description which other modules they require	[SWS_SwCluC_NA_00999]
[SRS_BSW_00385]	List possible error notifications	[SWS_SwCluC_02140] [SWS_SwCluC_02426] [SWS_SwCluC_02545] [SWS_SwCluC_02650] [SWS_SwCluC_02750] [SWS_SwCluC_03216] [SWS_SwCluC_09001]
[SRS_BSW_00386]	The BSW shall specify the configuration and conditions for detecting an error	[SWS_SwCluC_NA_00999]
[SRS_BSW_00388]	Containers shall be used to group configuration parameters that are defined for the same object	[SWS_SwCluC_NA_00999]
[SRS_BSW_00389]	Containers shall have names	[SWS_SwCluC_NA_00999]
[SRS_BSW_00390]	Parameter content shall be unique within the module	[SWS_SwCluC_NA_00999]
[SRS_BSW_00392]	Parameters shall have a type	[SWS_SwCluC_NA_00999]
[SRS_BSW_00393]	Parameters shall have a range	[SWS_SwCluC_NA_00999]
[SRS_BSW_00394]	The Basic Software Module specifications shall specify the scope of the configuration parameters	[SWS_SwCluC_NA_00999]





Requirement	Description	Satisfied by
[SRS_BSW_00395]	The Basic Software Module specifications shall list all configuration parameter dependencies	[SWS_SwCluC_NA_00999]
[SRS_BSW_00396]	The Basic Software Module specifications shall specify the supported configuration classes for changing values and multiplicities for each parameter/ container	[SWS_SwCluC_NA_00999]
[SRS_BSW_00397]	The configuration parameters in pre-compile time are fixed before compilation starts	[SWS_SwCluC_NA_00999]
[SRS_BSW_00398]	The link-time configuration is achieved on object code basis in the stage after compiling and before linking	[SWS_SwCluC_NA_00999]
[SRS_BSW_00399]	Parameter-sets shall be located in a separate segment and shall be loaded after the code	[SWS_SwCluC_NA_00999]
[SRS_BSW_00400]	Parameter shall be selected from multiple sets of parameters after code has been loaded and started	[SWS_SwCluC_NA_00999]
[SRS_BSW_00401]	Documentation of multiple instances of configuration parameters shall be available	[SWS_SwCluC_NA_00999]
[SRS_BSW_00402]	Each module shall provide version information	[SWS_SwCluC_NA_00999]
[SRS_BSW_00403]	The Basic Software Module specifications shall specify for each parameter/container whether it supports different values or multiplicity in different configuration sets	[SWS_SwCluC_NA_00999]
[SRS_BSW_00404]	BSW Modules shall support post-build configuration	[SWS_SwCluC_NA_00999]
[SRS_BSW_00405]	BSW Modules shall support multiple configuration sets	[SWS_SwCluC_NA_00999]





Requirement	Description	Satisfied by
[SRS_BSW_00406]	A static status variable denoting if a BSW module is initialized shall be initialized with value 0 before any APIs of the BSW module is called	[SWS_SwCluC_NA_00999]
[SRS_BSW_00408]	All AUTOSAR Basic Software Modules configuration parameters shall be named according to a specific naming rule	[SWS_SwCluC_NA_00999]
[SRS_BSW_00409]	All production code error ID symbols are defined by the Dem module and shall be retrieved by the other BSW modules from Dem configuration	[SWS_SwCluC_NA_00999]
[SRS_BSW_00410]	Compiler switches shall have defined values	[SWS_SwCluC_NA_00999]
[SRS_BSW_00411]	All AUTOSAR Basic Software Modules shall apply a naming rule for enabling/disabling the existence of the API	[SWS_SwCluC_NA_00999]
[SRS_BSW_00413]	An index-based accessing of the instances of BSW modules shall be done	[SWS_SwCluC_NA_00999]
[SRS_BSW_00414]	Init functions shall have a pointer to a configuration structure as single parameter	[SWS_SwCluC_NA_00999]
[SRS_BSW_00415]	Interfaces which are provided exclusively for one module shall be separated into a dedicated header file	[SWS_SwCluC_NA_00999]
[SRS_BSW_00416]	The sequence of modules to be initialized shall be configurable	[SWS_SwCluC_NA_00999]
[SRS_BSW_00417]	Software which is not part of the SW-C shall report error events only after the Dem is fully operational.	[SWS_SwCluC_NA_00999]
[SRS_BSW_00419]	If a pre-compile time configuration parameter is implemented as <code>const</code> it should be placed into a separate c-file	[SWS_SwCluC_NA_00999]
[SRS_BSW_00422]	Pre-de-bouncing of error status information is done within the Dem	[SWS_SwCluC_NA_00999]





Requirement	Description	Satisfied by
[SRS_BSW_00423]	BSW modules with AUTOSAR interfaces shall be describable with the means of the SW-C Template	[SWS_SwCluC_NA_00999]
[SRS_BSW_00424]	BSW module main processing functions shall not be allowed to enter a wait state	[SWS_SwCluC_NA_00999]
[SRS_BSW_00425]	The BSW module description template shall provide means to model the defined trigger conditions of schedulable objects	[SWS_SwCluC_NA_00999]
[SRS_BSW_00426]	BSW Modules shall ensure data consistency of data which is shared between BSW modules	[SWS_SwCluC_NA_00999]
[SRS_BSW_00427]	ISR functions shall be defined and documented in the BSW module description template	[SWS_SwCluC_NA_00999]
[SRS_BSW_00429]	Access to OS is restricted	[SWS_SwCluC_NA_00999]
[SRS_BSW_00432]	Modules should have separate main processing functions for read/receive and write/transmit data path	[SWS_SwCluC_NA_00999]
[SRS_BSW_00433]	Main processing functions are only allowed to be called from task bodies provided by the BSW Scheduler	[SWS_SwCluC_NA_00999]
[SRS_BSW_00437]	Memory mapping shall provide the possibility to define RAM segments which are not to be initialized during startup	[SWS_SwCluC_NA_00999]
[SRS_BSW_00438]	Configuration data shall be defined in a structure	[SWS_SwCluC_NA_00999]
[SRS_BSW_00439]	Enable BSW modules to handle interrupts	[SWS_SwCluC_NA_00999]
[SRS_BSW_00440]	The callback function invocation by the BSW module shall follow the signature provided by RTE to invoke servers via <code>Rte_Call</code> API	[SWS_SwCluC_NA_00999]
[SRS_BSW_00441]	Naming convention for type, macro and function	[SWS_SwCluC_01000] [SWS_SwCluC_01002]





Requirement	Description	Satisfied by
[SRS_BSW_00447]	Standardizing Include file structure of BSW Modules Implementing Autosar Service	[SWS_SwCluC_NA_00999]
[SRS_BSW_00448]	Module SWS shall not contain requirements from other modules	[SWS_SwCluC_NA_00999]
[SRS_BSW_00449]	BSW Service APIs used by Autosar Application Software shall return a Std_ReturnType	[SWS_SwCluC_NA_00999]
[SRS_BSW_00450]	A Main function of a un-initialized module shall return immediately	[SWS_SwCluC_NA_00999]
[SRS_BSW_00451]	Hardware registers shall be protected if concurrent access to these registers occur	[SWS_SwCluC_NA_00999]
[SRS_BSW_00452]	Classification of runtime errors	[SWS_SwCluC_NA_00999]
[SRS_BSW_00453]	BSW Modules shall be harmonized	[SWS_SwCluC_NA_00999]
[SRS_BSW_00454]	An alternative interface without a parameter of category DATA_REFERENCE shall be available.	[SWS_SwCluC_NA_00999]
[SRS_BSW_00456]	A Header file shall be defined in order to harmonize BSW Modules	[SWS_SwCluC_NA_00999]
[SRS_BSW_00457]	Callback functions of Application software components shall be invoked by the Basis SW	[SWS_SwCluC_NA_00999]
[SRS_BSW_00458]	Classification of production errors	[SWS_SwCluC_NA_00999]
[SRS_BSW_00459]	It shall be possible to concurrently execute a service offered by a BSW module in different partitions	[SWS_SwCluC_NA_00999]
[SRS_BSW_00460]	Reentrancy Levels	[SWS_SwCluC_NA_00999]
[SRS_BSW_00461]	Modules called by generic modules shall satisfy all interfaces requested by the generic module	[SWS_SwCluC_NA_00999]
[SRS_BSW_00462]	All Standardized Autosar Interfaces shall have unique requirement Id / number	[SWS_SwCluC_NA_00999]
[SRS_BSW_00463]	Naming convention of callout prototypes	[SWS_SwCluC_NA_00999]





Requirement	Description	Satisfied by
[SRS_BSW_00464]	File names shall be considered case sensitive regardless of the filesystem in which they are used	[SWS_SwCluC_NA_00999]
[SRS_BSW_00465]	It shall not be allowed to name any two files so that they only differ by the cases of their letters	[SWS_SwCluC_NA_00999]
[SRS_BSW_00466]	Classification of extended production errors	[SWS_SwCluC_NA_00999]
[SRS_BSW_00467]	The init / deinit services shall only be called by BswM or EcuM	[SWS_SwCluC_NA_00999]
[SRS_BSW_00469]	Fault detection and healing of production errors and extended production errors	[SWS_SwCluC_NA_00999]
[SRS_BSW_00470]	Execution frequency of production error detection	[SWS_SwCluC_NA_00999]
[SRS_BSW_00471]	Do not cause dead-locks on detection of production errors - the ability to heal from previously detected production errors	[SWS_SwCluC_NA_00999]
[SRS_BSW_00472]	Avoid detection of two production errors with the same root cause.	[SWS_SwCluC_NA_00999]
[SRS_BSW_00473]	Classification of transient faults	[SWS_SwCluC_NA_00999]
[SRS_BSW_00477]	The functional interfaces of AUTOSAR BSW modules shall be specified in C99	[SWS_SwCluC_NA_00999]
[SRS_BSW_00478]	Timing limits of main functions	[SWS_SwCluC_NA_00999]
[SRS_BSW_00479]	Interfaces for handling request from external devices	[SWS_SwCluC_NA_00999]
[SRS_BSW_00480]	Null pointer errors shall follow a naming rule	[SWS_SwCluC_02140] [SWS_SwCluC_02426] [SWS_SwCluC_02545] [SWS_SwCluC_02650] [SWS_SwCluC_02750] [SWS_SwCluC_03216] [SWS_SwCluC_09001]
[SRS_BSW_00481]	Invalid configuration set selection errors shall follow a naming rule	[SWS_SwCluC_NA_00999]
[SRS_BSW_00482]	Get version information function shall follow a naming rule	[SWS_SwCluC_09000] [SWS_SwCluC_91001]
[SRS_BSW_00483]	BSW Modules shall handle buffer alignments internally	[SWS_SwCluC_NA_00999]





Requirement	Description	Satisfied by
[SRS_BSW_00484]	Input parameters of scalar and enum types shall be passed as a value.	[SWS_SwCluC_NA_00999]
[SRS_BSW_00485]	Input parameters of structure type shall be passed as a reference to a constant structure	[SWS_SwCluC_NA_00999]
[SRS_BSW_00486]	Input parameters of array type shall be passed as a reference to the constant array base type	[SWS_SwCluC_NA_00999]
[SRS_BSW_00487]	Errors for module initialization shall follow a naming rule	[SWS_SwCluC_02140] [SWS_SwCluC_02426] [SWS_SwCluC_02545] [SWS_SwCluC_02650] [SWS_SwCluC_02750] [SWS_SwCluC_03216] [SWS_SwCluC_09001]
[SRS_BSW_00488]	Classification of security events	[SWS_SwCluC_NA_00999]
[SRS_BSW_00489]	Reporting of security events	[SWS_SwCluC_NA_00999]
[SRS_BSW_00490]	List possible security events	[SWS_SwCluC_NA_00999]
[SRS_BSW_00491]	Specification of trigger conditions and context data	[SWS_SwCluC_NA_00999]
[SRS_BSW_00492]	Reporting of security events during startup	[SWS_SwCluC_NA_00999]
[SRS_BSW_00493]	Definition of security event ID symbols	[SWS_SwCluC_NA_00999]
[SRS_BSW_00494]	ServiceInterface argument with a pointer datatype	[SWS_SwCluC_NA_00999]
[SRS_SwCluC_00001]	Easy target machine interpretation	[SWS_SwCluC_00001] [SWS_SwCluC_00003] [SWS_SwCluC_00004] [SWS_SwCluC_00005] [SWS_SwCluC_00006] [SWS_SwCluC_00007] [SWS_SwCluC_00008] [SWS_SwCluC_00009] [SWS_SwCluC_00010] [SWS_SwCluC_00011] [SWS_SwCluC_00012] [SWS_SwCluC_00015] [SWS_SwCluC_00016] [SWS_SwCluC_00017] [SWS_SwCluC_00018] [SWS_SwCluC_00019] [SWS_SwCluC_00020] [SWS_SwCluC_00021] [SWS_SwCluC_00022] [SWS_SwCluC_00023] [SWS_SwCluC_00024] [SWS_SwCluC_00025] [SWS_SwCluC_00026] [SWS_SwCluC_00027] [SWS_SwCluC_00028] [SWS_SwCluC_00029] [SWS_SwCluC_00030] [SWS_SwCluC_00031] [SWS_SwCluC_00032] [SWS_SwCluC_00033] [SWS_SwCluC_00034] [SWS_SwCluC_00035] [SWS_SwCluC_00036] [SWS_SwCluC_00037] [SWS_SwCluC_00040] [SWS_SwCluC_00041] [SWS_SwCluC_00042] [SWS_SwCluC_00070] [SWS_SwCluC_00072] [SWS_SwCluC_00079] [SWS_SwCluC_00080] [SWS_SwCluC_00081] [SWS_SwCluC_00082] [SWS_SwCluC_00083] [SWS_SwCluC_00085] [SWS_SwCluC_00090] [SWS_SwCluC_00095] [SWS_SwCluC_CONSTR_00073]
[SRS_SwCluC_00002]	Identification of intended connections by unique IDs	[SWS_SwCluC_00015] [SWS_SwCluC_00021] [SWS_SwCluC_00034] [SWS_SwCluC_00035] [SWS_SwCluC_00043]
[SRS_SwCluC_00003]	Bidirectional connections	[SWS_SwCluC_00024] [SWS_SwCluC_00026]
[SRS_SwCluC_00004]	Connection multiplicity	[SWS_SwCluC_00027] [SWS_SwCluC_00045] [SWS_SwCluC_00046] [SWS_SwCluC_00047] [SWS_SwCluC_00089]





Requirement	Description	Satisfied by
[SRS_SwCluC_00005]	Substitute Resource Providers	[SWS_SwCluC_00008] [SWS_SwCluC_00054] [SWS_SwCluC_00055] [SWS_SwCluC_CONSTR_00087]
[SRS_SwCluC_00006]	C API	[SWS_SwCluC_00002] [SWS_SwCluC_00062] [SWS_SwCluC_00063] [SWS_SwCluC_00064] [SWS_SwCluC_00065] [SWS_SwCluC_00066] [SWS_SwCluC_00067] [SWS_SwCluC_00068] [SWS_SwCluC_00069] [SWS_SwCluC_01000] [SWS_SwCluC_01002] [SWS_SwCluC_10000] [SWS_SwCluC_10001] [SWS_SwCluC_10002] [SWS_SwCluC_10003] [SWS_SwCluC_10004] [SWS_SwCluC_10005] [SWS_SwCluC_10006] [SWS_SwCluC_10007] [SWS_SwCluC_10008] [SWS_SwCluC_10009] [SWS_SwCluC_10010] [SWS_SwCluC_10011] [SWS_SwCluC_10020] [SWS_SwCluC_10021] [SWS_SwCluC_10022] [SWS_SwCluC_10023] [SWS_SwCluC_10032] [SWS_SwCluC_10033] [SWS_SwCluC_10034]
[SRS_SwCluC_00008]	Retrieve connection status and connected Software Cluster	[SWS_SwCluC_10021] [SWS_SwCluC_10023]
[SRS_SwCluC_00009]	Support missing interface partners	[SWS_SwCluC_00015] [SWS_SwCluC_00019] [SWS_SwCluC_00030] [SWS_SwCluC_00034] [SWS_SwCluC_00035] [SWS_SwCluC_00044]
[SRS_SwCluC_00010]	Static safeguard of Software Cluster connections	[SWS_SwCluC_00015] [SWS_SwCluC_00022] [SWS_SwCluC_03005] [SWS_SwCluC_03033] [SWS_SwCluC_03034] [SWS_SwCluC_03035] [SWS_SwCluC_03036] [SWS_SwCluC_03037] [SWS_SwCluC_03038] [SWS_SwCluC_03039] [SWS_SwCluC_03040] [SWS_SwCluC_03041] [SWS_SwCluC_03042] [SWS_SwCluC_03043] [SWS_SwCluC_03044] [SWS_SwCluC_03045] [SWS_SwCluC_03046] [SWS_SwCluC_03047]
[SRS_SwCluC_00011]	Separation of immutable memory and memory modifiable at the connection phase	[SWS_SwCluC_00001] [SWS_SwCluC_00003] [SWS_SwCluC_00004] [SWS_SwCluC_00005] [SWS_SwCluC_00006] [SWS_SwCluC_00007] [SWS_SwCluC_00008] [SWS_SwCluC_00009] [SWS_SwCluC_00010] [SWS_SwCluC_00011] [SWS_SwCluC_00012] [SWS_SwCluC_00015] [SWS_SwCluC_00028] [SWS_SwCluC_00029] [SWS_SwCluC_00030] [SWS_SwCluC_00031] [SWS_SwCluC_00032] [SWS_SwCluC_00033] [SWS_SwCluC_00034] [SWS_SwCluC_00035] [SWS_SwCluC_00042] [SWS_SwCluC_00070] [SWS_SwCluC_00072] [SWS_SwCluC_00079] [SWS_SwCluC_00080] [SWS_SwCluC_00081] [SWS_SwCluC_00082] [SWS_SwCluC_00083] [SWS_SwCluC_00085]
[SRS_SwCluC_00012]	direct linkage	[SWS_SwCluC_00057] [SWS_SwCluC_00058] [SWS_SwCluC_00059] [SWS_SwCluC_00060] [SWS_SwCluC_00061]
[SRS_SwCluC_00013]	Initialization with C-compiler and linker means	[SWS_SwCluC_00001] [SWS_SwCluC_00003] [SWS_SwCluC_00004] [SWS_SwCluC_00005] [SWS_SwCluC_00006] [SWS_SwCluC_00007] [SWS_SwCluC_00008] [SWS_SwCluC_00009] [SWS_SwCluC_00010] [SWS_SwCluC_00011] [SWS_SwCluC_00012] [SWS_SwCluC_00029] [SWS_SwCluC_00030] [SWS_SwCluC_00031] [SWS_SwCluC_00032] [SWS_SwCluC_00033] [SWS_SwCluC_00034] [SWS_SwCluC_00035] [SWS_SwCluC_00042] [SWS_SwCluC_00070] [SWS_SwCluC_00072]





Requirement	Description	Satisfied by
[SRS_SwCluC_00014]	Standardized persistence in memory	[SWS_SwCluC_00001] [SWS_SwCluC_00003] [SWS_SwCluC_00004] [SWS_SwCluC_00005] [SWS_SwCluC_00006] [SWS_SwCluC_00007] [SWS_SwCluC_00008] [SWS_SwCluC_00009] [SWS_SwCluC_00010] [SWS_SwCluC_00011] [SWS_SwCluC_00012] [SWS_SwCluC_00015] [SWS_SwCluC_00016] [SWS_SwCluC_00017] [SWS_SwCluC_00018] [SWS_SwCluC_00019] [SWS_SwCluC_00020] [SWS_SwCluC_00021] [SWS_SwCluC_00022] [SWS_SwCluC_00023] [SWS_SwCluC_00024] [SWS_SwCluC_00025] [SWS_SwCluC_00026] [SWS_SwCluC_00027] [SWS_SwCluC_00028] [SWS_SwCluC_00029] [SWS_SwCluC_00030] [SWS_SwCluC_00031] [SWS_SwCluC_00032] [SWS_SwCluC_00033] [SWS_SwCluC_00034] [SWS_SwCluC_00035] [SWS_SwCluC_00036] [SWS_SwCluC_00037] [SWS_SwCluC_00040] [SWS_SwCluC_00041] [SWS_SwCluC_00042] [SWS_SwCluC_00070] [SWS_SwCluC_00072] [SWS_SwCluC_00079] [SWS_SwCluC_00080] [SWS_SwCluC_00081] [SWS_SwCluC_00082] [SWS_SwCluC_00083] [SWS_SwCluC_00085] [SWS_SwCluC_00090] [SWS_SwCluC_00095] [SWS_SwCluC_CONSTR_00073] [SWS_SwCluC_CONSTR_00091] [SWS_SwCluC_CONSTR_00092] [SWS_SwCluC_CONSTR_00093] [SWS_SwCluC_CONSTR_00094]
[SRS_SwCluC_00100]	Cross Software Cluster Communication Plug-Ins	[SWS_SwCluC_03000] [SWS_SwCluC_03001] [SWS_SwCluC_03002] [SWS_SwCluC_03003] [SWS_SwCluC_03004] [SWS_SwCluC_03006] [SWS_SwCluC_03007] [SWS_SwCluC_03008] [SWS_SwCluC_03009] [SWS_SwCluC_03010] [SWS_SwCluC_03011] [SWS_SwCluC_03064] [SWS_SwCluC_03065] [SWS_SwCluC_03068] [SWS_SwCluC_03080] [SWS_SwCluC_03081] [SWS_SwCluC_03082] [SWS_SwCluC_03083] [SWS_SwCluC_03084] [SWS_SwCluC_03085] [SWS_SwCluC_03086] [SWS_SwCluC_03087] [SWS_SwCluC_03088] [SWS_SwCluC_03089] [SWS_SwCluC_03090] [SWS_SwCluC_03091] [SWS_SwCluC_03092] [SWS_SwCluC_03094] [SWS_SwCluC_03095] [SWS_SwCluC_03096] [SWS_SwCluC_03097] [SWS_SwCluC_03098] [SWS_SwCluC_03099] [SWS_SwCluC_03101] [SWS_SwCluC_03102] [SWS_SwCluC_03103] [SWS_SwCluC_03106] [SWS_SwCluC_03107] [SWS_SwCluC_03108] [SWS_SwCluC_03109] [SWS_SwCluC_03110] [SWS_SwCluC_03111] [SWS_SwCluC_03112] [SWS_SwCluC_03113] [SWS_SwCluC_03120] [SWS_SwCluC_03121] [SWS_SwCluC_03122] [SWS_SwCluC_03123] [SWS_SwCluC_03124] [SWS_SwCluC_03126] [SWS_SwCluC_03130] [SWS_SwCluC_03131] [SWS_SwCluC_03132] [SWS_SwCluC_03133] [SWS_SwCluC_03134] [SWS_SwCluC_03135] [SWS_SwCluC_03136] [SWS_SwCluC_03137] [SWS_SwCluC_03138] [SWS_SwCluC_03139] [SWS_SwCluC_03140] [SWS_SwCluC_03142] [SWS_SwCluC_03143] [SWS_SwCluC_03144] [SWS_SwCluC_03145] [SWS_SwCluC_03146] [SWS_SwCluC_03147] [SWS_SwCluC_03150] [SWS_SwCluC_03152] [SWS_SwCluC_03153] [SWS_SwCluC_03154] [SWS_SwCluC_03155] [SWS_SwCluC_03156] [SWS_SwCluC_03158] [SWS_SwCluC_03159] [SWS_SwCluC_03160] [SWS_SwCluC_03161] [SWS_SwCluC_03162] [SWS_SwCluC_03163] [SWS_SwCluC_03164] [SWS_SwCluC_03165] [SWS_SwCluC_03166] [SWS_SwCluC_03167] [SWS_SwCluC_03168] [SWS_SwCluC_03169] [SWS_SwCluC_03170] [SWS_SwCluC_03171] [SWS_SwCluC_03173] [SWS_SwCluC_03176] [SWS_SwCluC_03177] [SWS_SwCluC_03178] [SWS_SwCluC_03401] [SWS_SwCluC_03402] [SWS_SwCluC_11000] [SWS_SwCluC_11001] [SWS_SwCluC_CONSTR_03066] [SWS_SwCluC_CONSTR_03067] [SWS_SwCluC_CONSTR_03069] [SWS_SwCluC_CONSTR_03093] [SWS_SwCluC_CONSTR_03400] [SWS_SwCluC_CONSTR_03403]





Requirement	Description	Satisfied by
[SRS_SwCluC_00101]	'1:n' Sender-receiver communication	[SWS_SwCluC_03034] [SWS_SwCluC_03035] [SWS_SwCluC_03036] [SWS_SwCluC_03037] [SWS_SwCluC_03038] [SWS_SwCluC_03039] [SWS_SwCluC_03040] [SWS_SwCluC_03041] [SWS_SwCluC_03042] [SWS_SwCluC_03043] [SWS_SwCluC_03044] [SWS_SwCluC_03064] [SWS_SwCluC_03065] [SWS_SwCluC_03068] [SWS_SwCluC_03080] [SWS_SwCluC_03081] [SWS_SwCluC_03082] [SWS_SwCluC_03084] [SWS_SwCluC_03085] [SWS_SwCluC_03101] [SWS_SwCluC_03102] [SWS_SwCluC_03103] [SWS_SwCluC_03106] [SWS_SwCluC_03107] [SWS_SwCluC_03108] [SWS_SwCluC_03109] [SWS_SwCluC_03110] [SWS_SwCluC_03111] [SWS_SwCluC_03112] [SWS_SwCluC_03113] [SWS_SwCluC_03120] [SWS_SwCluC_03121] [SWS_SwCluC_03122] [SWS_SwCluC_03123] [SWS_SwCluC_03124] [SWS_SwCluC_03126] [SWS_SwCluC_03130] [SWS_SwCluC_03131] [SWS_SwCluC_03132] [SWS_SwCluC_03133] [SWS_SwCluC_03135] [SWS_SwCluC_03136] [SWS_SwCluC_03137] [SWS_SwCluC_03138] [SWS_SwCluC_03139] [SWS_SwCluC_03140] [SWS_SwCluC_03142] [SWS_SwCluC_03143] [SWS_SwCluC_03144] [SWS_SwCluC_03156] [SWS_SwCluC_03158] [SWS_SwCluC_03159]
[SRS_SwCluC_00102]	'n:1' Sender-receiver communication	[SWS_SwCluC_03034] [SWS_SwCluC_03035] [SWS_SwCluC_03036] [SWS_SwCluC_03037] [SWS_SwCluC_03038] [SWS_SwCluC_03039] [SWS_SwCluC_03040] [SWS_SwCluC_03041] [SWS_SwCluC_03042] [SWS_SwCluC_03043] [SWS_SwCluC_03044]
[SRS_SwCluC_00103]	'n:1' Client-server communication	[SWS_SwCluC_03035] [SWS_SwCluC_03036] [SWS_SwCluC_03037] [SWS_SwCluC_03038] [SWS_SwCluC_03039] [SWS_SwCluC_03040] [SWS_SwCluC_03041] [SWS_SwCluC_03042] [SWS_SwCluC_03043] [SWS_SwCluC_03044] [SWS_SwCluC_03047] [SWS_SwCluC_03083] [SWS_SwCluC_03086] [SWS_SwCluC_03087] [SWS_SwCluC_03088] [SWS_SwCluC_03089] [SWS_SwCluC_03090] [SWS_SwCluC_03091] [SWS_SwCluC_03092] [SWS_SwCluC_03094] [SWS_SwCluC_03095] [SWS_SwCluC_03096] [SWS_SwCluC_03097] [SWS_SwCluC_03098] [SWS_SwCluC_03099] [SWS_SwCluC_03134] [SWS_SwCluC_03145] [SWS_SwCluC_03146] [SWS_SwCluC_03147] [SWS_SwCluC_03150] [SWS_SwCluC_03152] [SWS_SwCluC_03153] [SWS_SwCluC_03154] [SWS_SwCluC_03155] [SWS_SwCluC_03160] [SWS_SwCluC_03161] [SWS_SwCluC_03162] [SWS_SwCluC_03163] [SWS_SwCluC_03164] [SWS_SwCluC_03165] [SWS_SwCluC_03166] [SWS_SwCluC_03167] [SWS_SwCluC_03168] [SWS_SwCluC_03169] [SWS_SwCluC_03170] [SWS_SwCluC_03171] [SWS_SwCluC_03173] [SWS_SwCluC_03176] [SWS_SwCluC_03177] [SWS_SwCluC_03178] [SWS_SwCluC_03401] [SWS_SwCluC_03402] [SWS_SwCluC_CONSTR_03093] [SWS_SwCluC_CONSTR_03403]
[SRS_SwCluC_00104]	'1:n' Mode Switch Communication	[SWS_SwCluC_03015] [SWS_SwCluC_03016] [SWS_SwCluC_03017] [SWS_SwCluC_03018] [SWS_SwCluC_03019] [SWS_SwCluC_03022] [SWS_SwCluC_03023] [SWS_SwCluC_03024] [SWS_SwCluC_03025] [SWS_SwCluC_03026] [SWS_SwCluC_03027] [SWS_SwCluC_03028] [SWS_SwCluC_03029] [SWS_SwCluC_03030] [SWS_SwCluC_03031] [SWS_SwCluC_03045] [SWS_SwCluC_03057] [SWS_SwCluC_03061] [SWS_SwCluC_03062] [SWS_SwCluC_03063] [SWS_SwCluC_CONSTR_03020] [SWS_SwCluC_CONSTR_03021] [SWS_SwCluC_CONSTR_03032]
[SRS_SwCluC_00105]	'1:n' External Trigger communication	[SWS_SwCluC_03046] [SWS_SwCluC_03048] [SWS_SwCluC_03049] [SWS_SwCluC_03050] [SWS_SwCluC_03051] [SWS_SwCluC_03052] [SWS_SwCluC_03055] [SWS_SwCluC_03056] [SWS_SwCluC_03058] [SWS_SwCluC_03060] [SWS_SwCluC_CONSTR_03053] [SWS_SwCluC_CONSTR_03054] [SWS_SwCluC_CONSTR_03059]
[SRS_SwCluC_00106]	'1:n' Parameter Communication	[SWS_SwCluC_03006] [SWS_SwCluC_03007] [SWS_SwCluC_03008] [SWS_SwCluC_03009] [SWS_SwCluC_03010] [SWS_SwCluC_03011] [SWS_SwCluC_03034] [SWS_SwCluC_03035] [SWS_SwCluC_03036] [SWS_SwCluC_03037] [SWS_SwCluC_03038] [SWS_SwCluC_03039] [SWS_SwCluC_03040] [SWS_SwCluC_03041] [SWS_SwCluC_03042] [SWS_SwCluC_03043] [SWS_SwCluC_03044]





Requirement	Description	Satisfied by
[SRS_SwCluC_00107]	Support unspecific preemption scenarios	[SWS_SwCluC_03084] [SWS_SwCluC_03085]
[SRS_SwCluC_00108]	Prevent from writing directly to memory of other Software Clusters	[SWS_SwCluC_11000] [SWS_SwCluC_11001]
[SRS_SwCluC_00201]	Standardized AUTOSAR Interfaces for software components	[SWS_SwCluC_02121] [SWS_SwCluC_02301] [SWS_SwCluC_02302] [SWS_SwCluC_02303] [SWS_SwCluC_02309] [SWS_SwCluC_02310] [SWS_SwCluC_02311] [SWS_SwCluC_02316] [SWS_SwCluC_02317] [SWS_SwCluC_02318] [SWS_SwCluC_02323] [SWS_SwCluC_02324] [SWS_SwCluC_02330] [SWS_SwCluC_02334] [SWS_SwCluC_02703] [SWS_SwCluC_02723] [SWS_SwCluC_02724] [SWS_SwCluC_02725] [SWS_SwCluC_02726] [SWS_SwCluC_02727] [SWS_SwCluC_02740] [SWS_SwCluC_02741] [SWS_SwCluC_02742] [SWS_SwCluC_02743] [SWS_SwCluC_03204]
[SRS_SwCluC_00202]	Standardized Interfaces for local BSW modules	[SWS_SwCluC_02125] [SWS_SwCluC_02212] [SWS_SwCluC_02225] [SWS_SwCluC_02507] [SWS_SwCluC_02510] [SWS_SwCluC_02511] [SWS_SwCluC_02512] [SWS_SwCluC_02513] [SWS_SwCluC_02514] [SWS_SwCluC_02515] [SWS_SwCluC_02516] [SWS_SwCluC_02517] [SWS_SwCluC_02609] [SWS_SwCluC_02610] [SWS_SwCluC_02611] [SWS_SwCluC_02612] [SWS_SwCluC_02618] [SWS_SwCluC_02619] [SWS_SwCluC_02620] [SWS_SwCluC_02621] [SWS_SwCluC_02622] [SWS_SwCluC_02623] [SWS_SwCluC_02702] [SWS_SwCluC_02703] [SWS_SwCluC_02704] [SWS_SwCluC_02705] [SWS_SwCluC_02706] [SWS_SwCluC_02707] [SWS_SwCluC_02736] [SWS_SwCluC_02737] [SWS_SwCluC_02738] [SWS_SwCluC_02739] [SWS_SwCluC_03202]
[SRS_SwCluC_00203]	Id abstraction	[SWS_SwCluC_02000]
[SRS_SwCluC_00204]	Modular Software Cluster Connection	[SWS_SwCluC_02007] [SWS_SwCluC_02101] [SWS_SwCluC_02144] [SWS_SwCluC_02200] [SWS_SwCluC_02201] [SWS_SwCluC_02338] [SWS_SwCluC_02339] [SWS_SwCluC_02500] [SWS_SwCluC_02501] [SWS_SwCluC_02600] [SWS_SwCluC_02601] [SWS_SwCluC_02748] [SWS_SwCluC_02749] [SWS_SwCluC_03214] [SWS_SwCluC_03215]
[SRS_SwCluC_00205]	Safeguarding connections between Software Clusters	[SWS_SwCluC_00015] [SWS_SwCluC_00022] [SWS_SwCluC_00042] [SWS_SwCluC_00043] [SWS_SwCluC_00077] [SWS_SwCluC_03005] [SWS_SwCluC_03033] [SWS_SwCluC_03034] [SWS_SwCluC_03035] [SWS_SwCluC_03036] [SWS_SwCluC_03037] [SWS_SwCluC_03038] [SWS_SwCluC_03039] [SWS_SwCluC_03040] [SWS_SwCluC_03041] [SWS_SwCluC_03042] [SWS_SwCluC_03043] [SWS_SwCluC_03044] [SWS_SwCluC_03045] [SWS_SwCluC_03046] [SWS_SwCluC_03047]
[SRS_SwCluC_00206]	NV blocks in Application Software Cluster	[SWS_SwCluC_02101] [SWS_SwCluC_02102] [SWS_SwCluC_02103] [SWS_SwCluC_02104] [SWS_SwCluC_02105] [SWS_SwCluC_02106] [SWS_SwCluC_02107] [SWS_SwCluC_02108] [SWS_SwCluC_02109] [SWS_SwCluC_02110] [SWS_SwCluC_02111] [SWS_SwCluC_02112] [SWS_SwCluC_02113] [SWS_SwCluC_02114] [SWS_SwCluC_02115] [SWS_SwCluC_02116] [SWS_SwCluC_02117] [SWS_SwCluC_02118] [SWS_SwCluC_02119] [SWS_SwCluC_02120] [SWS_SwCluC_02121] [SWS_SwCluC_02122] [SWS_SwCluC_02123] [SWS_SwCluC_02124] [SWS_SwCluC_02125] [SWS_SwCluC_02126] [SWS_SwCluC_02127] [SWS_SwCluC_02128] [SWS_SwCluC_02129] [SWS_SwCluC_02132] [SWS_SwCluC_02133] [SWS_SwCluC_02136] [SWS_SwCluC_02137] [SWS_SwCluC_02138] [SWS_SwCluC_02139] [SWS_SwCluC_02142] [SWS_SwCluC_02144] [SWS_SwCluC_CONSTR_02134] [SWS_SwCluC_CONSTR_02135] [SWS_SwCluC_CONSTR_02141]





Requirement	Description	Satisfied by
[SRS_SwCluC_00207]	LdCom Invocation from Application Software Cluster	[SWS_SwCluC_02500] [SWS_SwCluC_02501] [SWS_SwCluC_02502] [SWS_SwCluC_02503] [SWS_SwCluC_02504] [SWS_SwCluC_02505] [SWS_SwCluC_02506] [SWS_SwCluC_02507] [SWS_SwCluC_02508] [SWS_SwCluC_02509] [SWS_SwCluC_02510] [SWS_SwCluC_02511] [SWS_SwCluC_02512] [SWS_SwCluC_02513] [SWS_SwCluC_02514] [SWS_SwCluC_02515] [SWS_SwCluC_02516] [SWS_SwCluC_02517] [SWS_SwCluC_02518] [SWS_SwCluC_02519] [SWS_SwCluC_02520] [SWS_SwCluC_02521] [SWS_SwCluC_02522] [SWS_SwCluC_02523] [SWS_SwCluC_02524] [SWS_SwCluC_02525] [SWS_SwCluC_02526] [SWS_SwCluC_02527] [SWS_SwCluC_02528] [SWS_SwCluC_02529] [SWS_SwCluC_02530] [SWS_SwCluC_02531] [SWS_SwCluC_02532] [SWS_SwCluC_02533] [SWS_SwCluC_02534] [SWS_SwCluC_02535] [SWS_SwCluC_02536] [SWS_SwCluC_02537] [SWS_SwCluC_02538] [SWS_SwCluC_02539] [SWS_SwCluC_02540] [SWS_SwCluC_02541] [SWS_SwCluC_02542] [SWS_SwCluC_02543] [SWS_SwCluC_02544] [SWS_SwCluC_02550] [SWS_SwCluC_02551] [SWS_SwCluC_02552] [SWS_SwCluC_CONSTR_02546] [SWS_SwCluC_CONSTR_02547] [SWS_SwCluC_CONSTR_02555] [SWS_SwCluC_CONSTR_02556] [SWS_SwCluC_CONSTR_02557] [SWS_SwCluC_CONSTR_02558] [SWS_SwCluC_CONSTR_02559] [SWS_SwCluC_CONSTR_02560] [SWS_SwCluC_CONSTR_02561] [SWS_SwCluC_CONSTR_02562]
[SRS_SwCluC_00208]	Dcm contribution by Application Software Cluster	[SWS_SwCluC_02300] [SWS_SwCluC_02301] [SWS_SwCluC_02302] [SWS_SwCluC_02303] [SWS_SwCluC_02304] [SWS_SwCluC_02305] [SWS_SwCluC_02306] [SWS_SwCluC_02307] [SWS_SwCluC_02308] [SWS_SwCluC_02309] [SWS_SwCluC_02310] [SWS_SwCluC_02311] [SWS_SwCluC_02312] [SWS_SwCluC_02313] [SWS_SwCluC_02314] [SWS_SwCluC_02315] [SWS_SwCluC_02316] [SWS_SwCluC_02317] [SWS_SwCluC_02318] [SWS_SwCluC_02319] [SWS_SwCluC_02320] [SWS_SwCluC_02321] [SWS_SwCluC_02322] [SWS_SwCluC_02323] [SWS_SwCluC_02324] [SWS_SwCluC_02325] [SWS_SwCluC_02330] [SWS_SwCluC_02331] [SWS_SwCluC_02332] [SWS_SwCluC_02333] [SWS_SwCluC_02334] [SWS_SwCluC_02335] [SWS_SwCluC_02336] [SWS_SwCluC_02337] [SWS_SwCluC_02338] [SWS_SwCluC_02339] [SWS_SwCluC_02341] [SWS_SwCluC_02342] [SWS_SwCluC_02350] [SWS_SwCluC_02351] [SWS_SwCluC_02352] [SWS_SwCluC_02353] [SWS_SwCluC_02354] [SWS_SwCluC_02355] [SWS_SwCluC_02356] [SWS_SwCluC_02357] [SWS_SwCluC_02358] [SWS_SwCluC_02359] [SWS_SwCluC_02360] [SWS_SwCluC_02361] [SWS_SwCluC_02362] [SWS_SwCluC_02363] [SWS_SwCluC_02364] [SWS_SwCluC_02365] [SWS_SwCluC_02366] [SWS_SwCluC_02367] [SWS_SwCluC_02368] [SWS_SwCluC_02369] [SWS_SwCluC_02370] [SWS_SwCluC_02371] [SWS_SwCluC_02372] [SWS_SwCluC_02373] [SWS_SwCluC_02374] [SWS_SwCluC_02375] [SWS_SwCluC_02376] [SWS_SwCluC_02380] [SWS_SwCluC_02381] [SWS_SwCluC_02382] [SWS_SwCluC_02383] [SWS_SwCluC_02384] [SWS_SwCluC_02385] [SWS_SwCluC_02386] [SWS_SwCluC_02387] [SWS_SwCluC_02388] [SWS_SwCluC_02400] [SWS_SwCluC_02401] [SWS_SwCluC_02402] [SWS_SwCluC_02403] [SWS_SwCluC_02404] [SWS_SwCluC_02405] [SWS_SwCluC_02406] [SWS_SwCluC_02407] [SWS_SwCluC_02408] [SWS_SwCluC_02409] [SWS_SwCluC_02410] [SWS_SwCluC_02411] [SWS_SwCluC_02412] [SWS_SwCluC_02413] [SWS_SwCluC_02414] [SWS_SwCluC_02415] [SWS_SwCluC_02416] [SWS_SwCluC_02417] [SWS_SwCluC_02418] [SWS_SwCluC_02419] [SWS_SwCluC_02420] [SWS_SwCluC_02421] [SWS_SwCluC_02422] [SWS_SwCluC_02423] [SWS_SwCluC_02424] [SWS_SwCluC_02425]





Requirement	Description	Satisfied by
[SRS_SwCluC_00209]	Diagnostic Monitors in Application Software Cluster	[SWS_SwCluC_02700] [SWS_SwCluC_02701] [SWS_SwCluC_02702] [SWS_SwCluC_02703] [SWS_SwCluC_02704] [SWS_SwCluC_02705] [SWS_SwCluC_02706] [SWS_SwCluC_02707] [SWS_SwCluC_02708] [SWS_SwCluC_02709] [SWS_SwCluC_02710] [SWS_SwCluC_02711] [SWS_SwCluC_02712] [SWS_SwCluC_02713] [SWS_SwCluC_02714] [SWS_SwCluC_02715] [SWS_SwCluC_02716] [SWS_SwCluC_02717] [SWS_SwCluC_02718] [SWS_SwCluC_02719] [SWS_SwCluC_02723] [SWS_SwCluC_02724] [SWS_SwCluC_02725] [SWS_SwCluC_02726] [SWS_SwCluC_02727] [SWS_SwCluC_02728] [SWS_SwCluC_02729] [SWS_SwCluC_02730] [SWS_SwCluC_02731] [SWS_SwCluC_02732] [SWS_SwCluC_02733] [SWS_SwCluC_02734] [SWS_SwCluC_02735] [SWS_SwCluC_02736] [SWS_SwCluC_02737] [SWS_SwCluC_02738] [SWS_SwCluC_02739] [SWS_SwCluC_02740] [SWS_SwCluC_02741] [SWS_SwCluC_02742] [SWS_SwCluC_02743] [SWS_SwCluC_02744] [SWS_SwCluC_02745] [SWS_SwCluC_02746] [SWS_SwCluC_02747] [SWS_SwCluC_02748] [SWS_SwCluC_02749] [SWS_SwCluC_02751]
[SRS_SwCluC_00210]	Usage of Function Inhibitions in Application Software Cluster	[SWS_SwCluC_03200] [SWS_SwCluC_03201] [SWS_SwCluC_03202] [SWS_SwCluC_03203] [SWS_SwCluC_03204] [SWS_SwCluC_03205] [SWS_SwCluC_03206] [SWS_SwCluC_03207] [SWS_SwCluC_03208] [SWS_SwCluC_03209] [SWS_SwCluC_03210] [SWS_SwCluC_03211] [SWS_SwCluC_03212] [SWS_SwCluC_03213] [SWS_SwCluC_03214] [SWS_SwCluC_03215] [SWS_SwCluC_03217] [SWS_SwCluC_03218]
[SRS_SwCluC_00211]	Com Invocation from Application Software Cluster	[SWS_SwCluC_02548] [SWS_SwCluC_02549] [SWS_SwCluC_02600] [SWS_SwCluC_02601] [SWS_SwCluC_02602] [SWS_SwCluC_02603] [SWS_SwCluC_02604] [SWS_SwCluC_02605] [SWS_SwCluC_02606] [SWS_SwCluC_02607] [SWS_SwCluC_02608] [SWS_SwCluC_02609] [SWS_SwCluC_02610] [SWS_SwCluC_02611] [SWS_SwCluC_02612] [SWS_SwCluC_02613] [SWS_SwCluC_02614] [SWS_SwCluC_02615] [SWS_SwCluC_02616] [SWS_SwCluC_02617] [SWS_SwCluC_02618] [SWS_SwCluC_02619] [SWS_SwCluC_02620] [SWS_SwCluC_02621] [SWS_SwCluC_02622] [SWS_SwCluC_02623] [SWS_SwCluC_02624] [SWS_SwCluC_02625] [SWS_SwCluC_02626] [SWS_SwCluC_02627] [SWS_SwCluC_02628] [SWS_SwCluC_02629] [SWS_SwCluC_02630] [SWS_SwCluC_02631] [SWS_SwCluC_02632] [SWS_SwCluC_02633] [SWS_SwCluC_02634] [SWS_SwCluC_02636] [SWS_SwCluC_02637] [SWS_SwCluC_02638] [SWS_SwCluC_02639] [SWS_SwCluC_02640] [SWS_SwCluC_02642] [SWS_SwCluC_02643] [SWS_SwCluC_02644] [SWS_SwCluC_02645] [SWS_SwCluC_02646] [SWS_SwCluC_02647] [SWS_SwCluC_02648] [SWS_SwCluC_02649] [SWS_SwCluC_02651] [SWS_SwCluC_02652] [SWS_SwCluC_02661] [SWS_SwCluC_02662] [SWS_SwCluC_02663] [SWS_SwCluC_CONSTR_02554] [SWS_SwCluC_CONSTR_02653] [SWS_SwCluC_CONSTR_02654] [SWS_SwCluC_CONSTR_02655] [SWS_SwCluC_CONSTR_02656] [SWS_SwCluC_CONSTR_02657] [SWS_SwCluC_CONSTR_02658] [SWS_SwCluC_CONSTR_02659] [SWS_SwCluC_CONSTR_02660]
[SRS_SwCluC_00300]	A2L Generation Support	[SWS_SwCluC_03071] [SWS_SwCluC_03072] [SWS_SwCluC_03073] [SWS_SwCluC_03074] [SWS_SwCluC_03075] [SWS_SwCluC_03076] [SWS_SwCluC_03077]

Table 6.1: RequirementsTracing

7 Functional specification

7.1 Binary Manifest

7.1.1 Overview

With the concept of [Software Clusters](#), the overall software of an AUTOSAR Classic Platform Architecture can be split into smaller units. In such a clustered AUTOSAR Classic Platform Architecture a resource is used to describes any capability which

- is needed to operate the software in [Software Clusters](#)

AND

- which is provided by one [Software Cluster](#) for another [Software Clusters](#)

Please note as well document [15] with its description about [CpSoftwareClusterResources](#).

Each [Software Cluster](#) is an independent build unit, and the result of the cluster-specific build processes are the [Binary Objects](#). The [Binary Manifests](#) provide the means to connect the [Binary Objects](#) that are deployed on the same [machine](#). Hence, the [Binary Manifest](#) is the well-defined interface of the [Software Cluster's Binary Object](#).

The [Binary Manifest](#) provides any information, which is required to access a resource inside a [Software Cluster](#), and to connect provided and required resources of [Software Clusters](#). A resource, in this context, can be anything that is required to operate the software. For example, a sender receiver interface of the [Software Cluster](#) or a NV block. An obvious property of such a resource is, whether it is provided or required by a [Software Cluster](#).

The [Binary Manifest](#) has the following core characteristics:

- The [Binary Manifest](#) gets created during the build of the [Software Cluster](#), since it has to store information which might be build dependent (e.g. data and function addresses, ID values to use BSW APIs, attribute values, hashes)
- The [Binary Manifest](#) provides a C interface towards [Software Cluster's](#) implementation. This supports an abstraction in the other functional blocks of the [Software Cluster Connection](#) from the [Binary Manifest's](#) table implementation. The C interface is also accessible by implementations of CDDs requiring the usage of the [Binary Manifest](#).
- The [Binary Manifest](#) defines an ECU-C interface to [Software Cluster's](#) build tools. This supports an abstract usage of the [Binary Manifest](#) by other functional blocks of the [Software Cluster Connection](#), as well as the usage of the [Binary Manifest](#) by CDDs.

- The **Binary Manifest** format can be easily interpreted by the target **machine**. Note: In contrast to concepts for other domains (e.g. Java, Android), in this specification it is not the goal to provide a textual manifest (XML, JSON).
- An unique identifier per resource is used for the connection process. These are explicitly assigned since hash numbers are not suitable.
- The **Binary Manifest** shall have guarding information, to ensure that only compatible interfaces are getting connected. These guarding values consist of a hash over certain interface properties (see 7.3.2.2 and 7.5).

7.1.2 Logical structure of a Binary Manifest

The Figure 7.1 provides an overview of the conceptual elements of the **Binary Manifest** necessary for a fictional example resource.

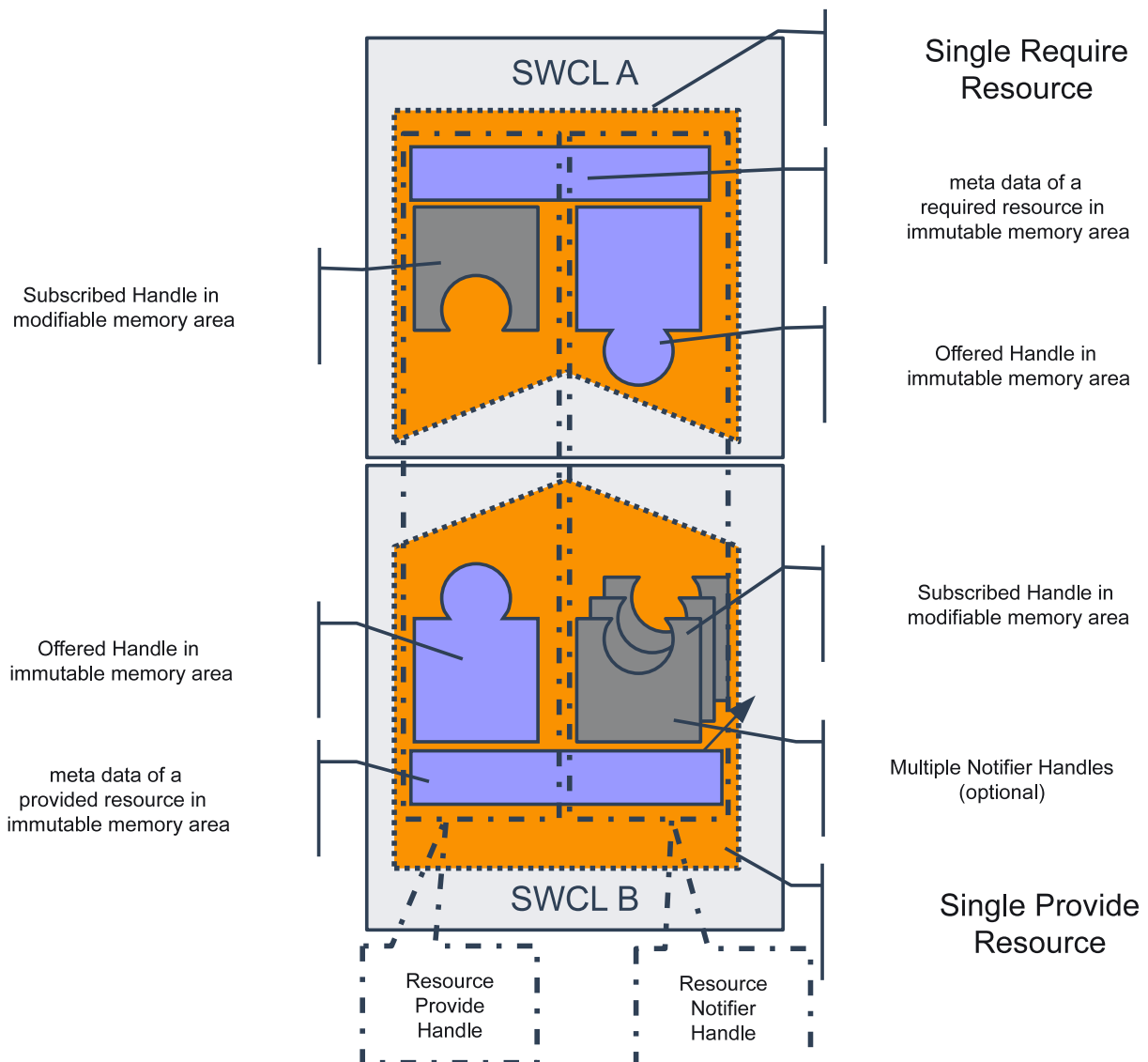

Figure 7.1: Logical structure of a Binary Manifest

The [Binary Manifest](#) provides the ability to connect required and provided resources of Software Clusters. Each resource is qualified by a set of meta data, e.g.

- the unique identifier of the resource
- the type of the resource (e.g. a sender receiver communication or connection of NV blocks)
- the nature, whether a resource is required or provided by this [Software Cluster](#)
- in case of required resources, whether it is mandatory for the operation of the [Software Cluster](#)
- guarding information (e.g. hash values) to ensure that only compatible resources are getting connected
- the number of stored handles, and where those handles can be found in the the according tables

Each type of resource is qualified by the number of handles, their purpose for the connection, and the order in which they are placed in the [Binary Manifest](#). The handles hold the information, which the [Software Cluster](#) requesting a resource needs to access it in the providing [Software Cluster](#).

A single handle can be

- a data pointer
- a function pointer
- a value

In some cases, a connection of a resource may require the exchange of handles in both directions. Consistently the [Binary Manifest](#) distinguishes between two types of handles on the logical level:

- [Provide Handle](#) to publish a handle from resource provider to resource requester
- [Notifier Handle](#) to publish a handle from resource requester to resource provider

An example for a [Provide Handle](#) would be a propagated API function to call an AUTOSAR Service from a [Application Software Cluster](#).

An example for a [Notifier Handle](#) would be a callback notification from a connected AUTOSAR Service.

In addition, it is supported that a resource provider gets connected to multiple resource requester even if it utilizes [Notifier Handles](#). But in this case for each potential resource requester a own set of [Notifier Handles](#) needs to be reserved for each resource requester. Hence a [Notifier Handle Set](#) holds all the [Notifier Handles](#) for one resource requester.

The [Binary Manifest](#) is composed of the following parts:

- the [Binary Manifest Header](#). It is the central entry point, provides administrative data and references to the other parts of the manifest.
- the [Interface Descriptor Table](#). It contains one row of meta information per [Resource Entry](#) (required or provided interface) - unique ID, properties to operate the resource at run-time, hash values about interface characteristics and semantics.
- the [Offered Interface](#). It contains all handles that are offered to other clusters - as explained above, either because a resource is provided, or because a required resource also needs a handle in the other direction.
- the [Subscribed Interface](#). Vice versa, it contains all handles that this [Software Cluster](#) holds that were offered by other [Software Clusters](#)
- checksums and markers ([Immutable Tables Checksum](#), [Subscribed Interface Validity Marker](#))

Some parts of the [Binary Manifest](#) are fixed when building a [Software Cluster](#), called immutable, while others have to be changed in the connection process, called modifiable:

- immutable
 - the [Binary Manifest Header](#)
 - the [Interface Descriptor Table](#)
 - offered handles
 - the default value for subscribed handles, to support operation in the unconnected state
- modifiable To establish a connection, this memory area has to store the handles from other SWCLs. Additionally, information might be stored to identify whether the resource is connected at all (only defaults are visible) and to which SWCL.

7.1.3 Mapping between Logical structure and Configuration structure

The logical structure shown in [Figure 7.1](#) is also reflected in the configuration structure of the [Binary Manifest](#).

The set of handles, relevant to connect one type of resource, is defined in the [SwCluCBManifResourceType](#). A [Resource Type](#) is characterized by a defined set of [Provide Handles](#) and [Notifier Handles](#), with specific types in a well defined order.

Handles can optionally exist. This is useful for resources which do not always need the full set of handles in all feature configurations. For instance, sender receiver commu-

nication works with or without `sendIndication`. Spending always a new resource type id (`SwCluCBManifResourceId`) is not appropriate due to the limited numberspace! But the Resource Provider and Resource Requester have to have the same mutual understanding of the optionality conditions and both have to see a matching configuration to determine the identical handle configuration for a particular `CpSoftwareClusterResource`.

This is the prerequisite to enable the connection between Software Clusters.

Optional handles are always added after the non-optional ones!

In addition it is highly recommended that the configuration values resulting in different handle configurations are also considered for the guard value calculation.

Each required or provided resource of this `Software Cluster` corresponds to one `Resource Entry` in the `Binary Manifest`.

One `Resource Entry` corresponds to exactly one row in the `Interface Descriptor Table`, plus one or several handles in the `Offered Interface` and / or `Subscribed Interface`. Depending whether the resource is required or provided, `Provide Handles` and `Notifier Handles` are implemented in the `Software Cluster` or expected to be set by the other `Software Cluster`. Please note as well Table 7.1.

Therefore, the configuration provides two distinct definitions for `Provide Resource Entrys` as `SwCluCBManifProvideResourceEntry` and `Require Resource Entrys` as `SwCluCBManifRequireResourceEntry`.

From a `Binary Manifest` user perspective, it is an important use case to iterate over uniform `Resource Entrys` by an index. For this purpose, the configuration provides the ability to group `Resource Entrys` of the same `Resource Type` in `Resource Entry Groups`. A `Provide Resource Entry Group`, being a group of `Provide Resource Entrys`, is represented as `SwCluCBManifProvideResourceEntryGroup`. Correspondingly, a `Require Resource Entry Group`, being a group of `Require Resource Entrys`, is represented as `SwCluCBManifRequireResourceEntryGroup`.

In this and the previous section, three pairs of terms have been introduced, for three different logical layers within the `Binary Manifest`:

1. provide and require resources
2. `Provide Handles` and `Notifier Handles`
3. offered and subscribed handles

A single connection (between provide and require resource, 1), consists of one or more logical channels (provide and notifier handles, 2), which are implemented in the binary manifest (offered and subscribed handles, 3).

An analogy might help to clarify these terms.

Consider a satellite receiver connected to a TV via a cable, which internally contains many wires. The satellite receiver provides 'video', the TV requests it (provide and require resource). To make a single connection between provide and require side, multiple separate data flows (provide and notifier handles) are required. Some transmit the video and audio signal from the provider to the requestor, while others transmit remote control signals in the opposite direction. Both the TV and the satellite receiver have a connector with many pins (provide and notifier handles).

For the 'left audio channel' ([Provide Handle](#)), a certain pin is used. On that pin, the satellite receiver sends a signal (an offered handle implements this [Provide Handle](#)), which the TV reads from the same pin (a subscribed handle implements this [Provide Handle](#)). For the 'remote control signal' ([Notifier Handle](#)) pin, the TV sends the signal (offered handle implements the [Notifier Handles](#)), while the satellite receiver reads the signal (subscribed handle implements the [Notifier Handles](#)).

The possible combinations of the three layers are shown in table [7.1](#).

7.1.4 Implementation structure of a Binary Manifest

Usually, in AUTOSAR the implementation of BSW modules is not standardized. But the various data tables of the [Binary Manifest](#) implement an interface to [Software Cluster](#) connector algorithms. Therefore, the implemented layout and semantic of the tables is standardized in this document. Furthermore, an abstract set of requirements for such connector algorithms is defined in section [7.1.5](#).

The Figure [7.2](#) provides an overview about the individual tables of the [Binary Manifest](#), and their main relationships.

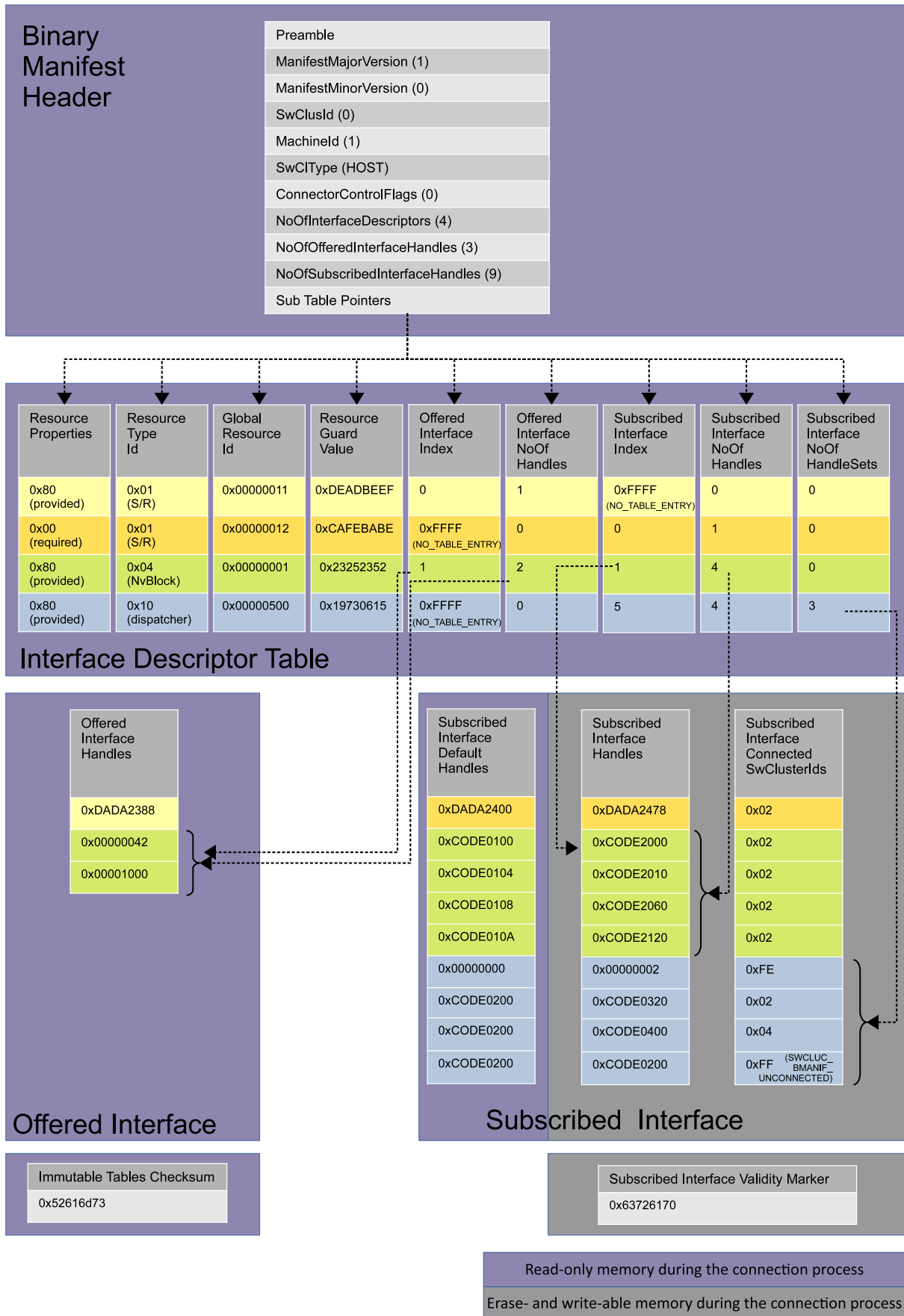

Figure 7.2: Implementation structure of a Binary Manifest

7.1.4.1 Implementation Overview

Each `Software Cluster`'s `Binary Manifest` has a central entry point, called the `Binary Manifest Header`. It contains the AUTOSAR standardized meta data of a `Software Cluster`, and pointers to the sub tables (and their columns, as explained below) of the `Binary Manifest`. It is specified in 7.1.4.3.

Each row in the `Interface Descriptor Table` stores the properties of a single resource. For instance, the global resource Id. To avoid alignment gaps and padding bytes, which could occur if multiple elements are put in a structure, the table is not stored as an array of such a structure. Instead, the individual properties are organized in separate arrays. The individual arrays of the `Interface Descriptor Table` are required to have exactly the same number of elements and the identical order. In other words, these arrays can be seen as the columns of the `Interface Descriptor Table` and the identical index denotes the table row. Each row describes one resource. It is specified in 7.1.4.4.

Each of these resources can now use a dedicated number of handles in the offered and / or subscribed handle tables. The indication of the associated handles is done with the start index for the interface table(s) and the number of handles in the interface table(s). Since the number and placement of offered and subscribed handles can differ, a separate 'index' and a separate 'number of handles' for offered and subscribed handle tables exist. A special `NO_TABLE_ENTRY` value in the index indicates that no handle exists in that table. In this case, the number of handles is set to zero.

For example, in figure 7.2, the resource with id `0x11` (marked yellow) has 1 offered handle at index 0 and no subscribed handle (indicated by `NO_TABLE_ENTRY`). The resource with id `0x1` (marked green), has two handles in the offered table (starting at index 1) and four handles in the subscribed table (also starting at index 1).

The Offered Interface consists of one array - the Offered Interface Handle Column - to store the fixed handles, which are offered for the connection process (for example, in the case of a send port, the addresses of the data buffer related to the port that this software cluster provides). It is specified in 7.1.4.5

The Subscribed Interface consists out of three arrays:

- Subscribed Interface Default Handle Column offers default values for the subscribed handles, which are used in case the connection process does not have a connection partner in another `Software Cluster`.
- Subscribed Interface Handle Column holds the handles modified by the connection process. Those values are taken during the connection process from the Offered Interface Handle Column of another `Software Cluster`.
- The Subscribed Interface Connected SwClusterId Column holds the Software Cluster Id, from which the handle values are taken.

It is specified in 7.1.4.6.

Please note that the [Subscribed Interface Handle Column](#) and [Subscribed Interface Connected SwClusterId Column](#) need to be located in a memory area that can be erased and re-written during the connection process. In contrast, the [Subscribed Interface Default Handle Column](#) (like all the other [Binary Manifest](#) tables) needs to be located in a memory area which is read-only during the connection process. This split ensures that the connection process can be re-started at any point of time - even if the [Subscribed Interface Handle Column](#) and [Subscribed Interface Connected SwClusterId Column](#) is already erased and not yet re-written.

7.1.4.2 Multiple Notifier Sets Introduction

To support 1:n connections that require individual notifications of the requesters, the [Binary Manifest](#) supports the storage of multiple [Notifier Handle Sets](#). In this case, the `SubscribedInterfaceNoOfHandleSets` field describes how many handles sets of other Software Clusters can be connected. Please note that the value 0 means that only a single connection is supported. 1..n means multiple connections are possible. If this is selected, the first handle entry is used to store the actual number of connected [Software Clusters](#) - similar to a dynamic length array. With this handling, it possible to preserve the `MULTIPLE_NOTIFIER_SETS` semantic for a [Binary Manifest](#) user, even if only at most one connection is supported.

It is also possible to connect interfaces that require more than one handle per connection. The number of handles per connection is not stored in the [Binary Manifest](#), but if it is required, it can be calculated as $(\text{SubscribedInterfaceNoOfHandles} - 1) / \text{SubscribedInterfaceNoOfHandleSets}$.

As an example, in figure 7.2, the resource with id 0x500 (marked blue) has 3 handle sets (the entry in the column `SubscribedInterfaceNoOfHandleSets` is set to 3). So at most three connections can be made to this resource. In this example, each of the three handle set consists of one handle, and since one more row is used for meta information, `SubscribedInterfaceNoOfHandles` is set to $3 * 1 + 1 = 4$.

As explained above, the number of established connections is stored in the first handle entry. In this case, the entry is set to 0x2, so two connections are used and one is unused. The value 0xFE in `SubscribedInterfaceConnectedClusterIds` additionally indicates that this row does not contain a handle. The next two rows each show the target address of the handle and the cluster id. Since the last connection is currently unused, in the last row the handle value is set to the default value, and `SubscribedInterfaceConnectedClusterIds` is set to `SWCLUC_BMANIF_UNCONNECTED (0xFF)`.

More in depth information about multiple [Notifier Handle Sets](#) can be found in 7.1.5.4. As part of that chapter, table 7.2 also shows an example with four sets, where each set consists of two handles.

7.1.4.3 Binary Manifest Header

[SWS_SwCluC_00001]{DRAFT} [The [Binary Manifest](#) of the [Software Cluster Connection](#) shall provide exactly one instance of the [Binary Manifest Header](#)

```
1 const SwCluC_BManif_HeaderType SwCluC_BManif_Header =
2   { <initialization> };
```

]([SRS_SwCluC_00001](#), [SRS_SwCluC_00011](#), [SRS_SwCluC_00013](#), [SRS_SwCluC_00014](#))

[SWS_SwCluC_00002]{DRAFT} [The header file `SwCluC_BManif.h` shall export the declaration of the [Binary Manifest Header](#)

```
1 extern const SwCluC_BManif_HeaderType SwCluC_BManif_Header;
```

]([SRS_SwCluC_00006](#))

[SWS_SwCluC_00003]{DRAFT} [The element `Preamble` of the [Binary Manifest Header](#) shall be set to the value `0x41524350464C4558`.]([SRS_SwCluC_00001](#), [SRS_SwCluC_00011](#), [SRS_SwCluC_00013](#), [SRS_SwCluC_00014](#))

Note: The purpose of the `Preamble` is to serve as an obvious marker of the [Binary Manifest](#)'s begin in memory. In addition, the value is chosen so that byte and word order can be detected, when the [Binary Manifest](#) is read in a byte stream or from a [Binary Object](#) file.

[SWS_SwCluC_00004]{DRAFT} [The element `ManifestMajorVersion` of the [Binary Manifest Header](#) shall be set to the value `0x01`.]([SRS_SwCluC_00001](#), [SRS_SwCluC_00011](#), [SRS_SwCluC_00013](#), [SRS_SwCluC_00014](#))

[SWS_SwCluC_00005]{DRAFT} [The element `ManifestMinorVersion` of the [Binary Manifest Header](#) shall be set to the value `0x01`.]([SRS_SwCluC_00001](#), [SRS_SwCluC_00011](#), [SRS_SwCluC_00013](#), [SRS_SwCluC_00014](#))

[SWS_SwCluC_00006]{DRAFT} [The element `SwClusterId` of the [Binary Manifest Header](#) shall be set to the value of the configuration parameter `SwCluC-SoftwareClusterId` of the selected [SwCluCDefinition](#).]([SRS_SwCluC_00001](#), [SRS_SwCluC_00011](#), [SRS_SwCluC_00013](#), [SRS_SwCluC_00014](#))

[SWS_SwCluC_00007]{DRAFT} [The element `MachineId` of the [Binary Manifest Header](#) shall be set to the value of the configuration parameter `SwCluC-MachineId` of the selected [SwCluCDefinition](#).]([SRS_SwCluC_00001](#), [SRS_SwCluC_00011](#), [SRS_SwCluC_00013](#), [SRS_SwCluC_00014](#))

[SWS_SwCluC_00008]{DRAFT} [The element `SwClusterType` of the [Binary Manifest Header](#) shall be set according to the value of the configuration parameter `SwCluCSoftwareClusterType` of the selected [SwCluCDefinition](#) with the following encoding:

- `HOST_SW_CLUSTER` : `0x00`

- APPLICATION_SW_CLUSTER : 0x01
- SUBSTITUTION_SW_CLUSTER : 0xFF

|(SRS_SwCluC_00001, SRS_SwCluC_00011, SRS_SwCluC_00013, SRS_SwCluC_00014, SRS_SwCluC_00005)

[SWS_SwCluC_00009]{DRAFT} [The bit SWCLUC_BMANIF_DISABLE_ON_ECU_CONNECTION in the element ConnectorControlFlags of the Binary Manifest Header shall be set if the SwCluCBManifOnBoardConnectorControl is set to DISABLE_ON_ECU_CONNECTOR. Otherwise, the bit is not set (value 0).](SRS_SwCluC_00001, SRS_SwCluC_00011, SRS_SwCluC_00013, SRS_SwCluC_00014)

Note: It is not specified, if it is possible to reflash a cluster with changed addresses, how a system would detect this, and how it would behave in this case. This might change in future releases of this specification.

[SWS_SwCluC_00010]{DRAFT} [The element NoOfInterfaceDescriptors of the Binary Manifest Header shall be set to the number of SwCluCBManifProvideResourceEntry + number of SwCluCBManifRequireResourceEntry containers in the configuration.](SRS_SwCluC_00001, SRS_SwCluC_00011, SRS_SwCluC_00013, SRS_SwCluC_00014)

[SWS_SwCluC_00011]{DRAFT} [The element NoOfOfferedInterfaceHandles of the Binary Manifest Header shall be set to the number of offered handles.](SRS_SwCluC_00001, SRS_SwCluC_00011, SRS_SwCluC_00013, SRS_SwCluC_00014)

[SWS_SwCluC_00012]{DRAFT} [The element NoOfSubscribedInterfaceHandles of the Binary Manifest Header shall be set to the number of handles in the Subscribed Interface.](SRS_SwCluC_00001, SRS_SwCluC_00011, SRS_SwCluC_00013, SRS_SwCluC_00014)

[SWS_SwCluC_00070]{DRAFT} [The element ImmutableTablesChecksumPtr of the Binary Manifest Header shall reference the Immutable Tables Checksum.](SRS_SwCluC_00001, SRS_SwCluC_00011, SRS_SwCluC_00013, SRS_SwCluC_00014)

[SWS_SwCluC_00072]{DRAFT} [The element SubscribedInterfaceValidityMarkerPtr of the Binary Manifest Header shall reference the Subscribed Interface Validity Marker.](SRS_SwCluC_00001, SRS_SwCluC_00011, SRS_SwCluC_00013, SRS_SwCluC_00014)

[SWS_SwCluC_00042]{DRAFT} [The elements

- ResourcePropertiesDescriptorColumnPtr
- ResourceTypeDescriptorColumnPtr
- GlobalResourceIdDescriptorColumnPtr
- ResourceGuardValueDescriptorColumnPtr

- OfferedInterfaceIndexDescriptorColumnPtr
- OfferedInterfaceNoOfHandlesDescriptorColumnPtr
- SubscribedInterfaceIndexDescriptorColumnPtr
- SubscribedInterfaceNoOfHandlesDescriptorColumnPtr
- SubscribedInterfaceNoOfHandleSetsDescriptorColumnPtr
- OfferedInterfaceHandleColumnPtr
- SubscribedInterfaceHandleDefaultColumnPtr
- SubscribedInterfaceHandleColumnPtr
- SubscribedInterfaceConnectedSwClusterIdColumnPtr

of the [Binary Manifest Header](#) shall reference the according array of the [Interface Descriptor Table](#) if the `SwCluC_BManifDescriptorTreatment` is set to `EMBED_DESCRIPTOR`. Otherwise the elements are initialized to `NULL_PTR`.] ([SRS_SwCluC_00001](#), [SRS_SwCluC_00011](#), [SRS_SwCluC_00013](#), [SRS_SwCluC_00014](#), [SRS_SwCluC_00205](#))

The order of the elements given by the data type [SwCluC_BManif_HeaderType](#).

7.1.4.4 Interface Descriptor Table

[[SWS_SwCluC_00015](#)]{DRAFT} [If the `SwCluC_BManifDescriptorTreatment` is set to `EMBED_DESCRIPTOR` the [Binary Manifest of the Software Cluster Connection](#) shall provide exactly one instance of the [Interface Descriptor Table](#) composed out of the following column arrays:

```

1  /* descriptor table column for resource properties */
2  const SwCluC_BManif_ResourcePropertiesType
      SwCluC_BManif_ResourcePropertiesDescriptorColumn[
          SWCLUC_BMANIF_NO_OF_DESCRIPTOR] = { <initialization> };
3
4  /* descriptor table column for resource type Ids */
5  const SwCluC_BManif_ResourceTypeIdType
      SwCluC_BManif_ResourceTypeIdDescriptorColumn[
          SWCLUC_BMANIF_NO_OF_DESCRIPTOR] = { <initialization> };
6
7  /* descriptor table column for global resource Ids */
8  const SwCluC_BManif_GlobalResourceIdType
      SwCluC_BManif_GlobalResourceIdDescriptorColumn[
          SWCLUC_BMANIF_NO_OF_DESCRIPTOR] = { <initialization> };
9
10 /* descriptor table column for guard values */
11 const SwCluC_BManif_ResourceGuardValueType
      SwCluC_BManif_ResourceGuardValueDescriptorColumn[
          SWCLUC_BMANIF_NO_OF_DESCRIPTOR] = { <initialization> };
12
13 /* descriptor table column for offered interface table index */

```



```

14 const SwCluC_BManif_TableIndexType
    SwCluC_BManif_OfferedInterfaceIndexDescriptorColumn[
        SWCLUC_BMANIF_NO_OF_DESCRIPTOR] = { <initialization> };
15
16 /* descriptor table column for number of handles in offered interface
    table*/
17 const SwCluC_BManif_HandleIndexType
    SwCluC_BManif_OfferedInterfaceNoOfHandlesDescriptorColumn[
        SWCLUC_BMANIF_NO_OF_DESCRIPTOR] = { <initialization> };
18
19 /* descriptor table column for subscribed interface table index */
20 const SwCluC_BManif_TableIndexType
    SwCluC_BManif_SubscribedInterfaceIndexDescriptorColumn[
        SWCLUC_BMANIF_NO_OF_DESCRIPTOR] = { <initialization> };
21
22 /* descriptor table column for number of handles in subscribed
    interface table*/
23 const SwCluC_BManif_HandleIndexType
    SwCluC_BManif_SubscribedInterfaceNoOfHandlesDescriptorColumn[
        SWCLUC_BMANIF_NO_OF_DESCRIPTOR] = { <initialization> };
24
25 /* descriptor table column for number of handle sets in subscribed
    interface table*/
26 const SwCluC_BManif_HandleIndexType
    SwCluC_BManif_SubscribedInterfaceNoOfHandleSetsDescriptorColumn[
        SWCLUC_BMANIF_NO_OF_DESCRIPTOR] = { <initialization> };

```

|(SRS_SwCluC_00001, SRS_SwCluC_00014, SRS_SwCluC_00002, SRS_SwCluC_00009, SRS_SwCluC_00010, SRS_SwCluC_00011, SRS_SwCluC_00205)

[SWS_SwCluC_00016]{DRAFT} [For each `SwCluC_BManif_ProvideResourceEntry` and `SwCluC_BManif_RequireResourceEntry` in a Software Cluster's configuration, the Binary Manifest of the Software Cluster Connection shall provide one row in the Interface Descriptor Table.](SRS_SwCluC_00001, SRS_SwCluC_00014)

Note: This means that each array in the Interface Descriptor Table gets one element per row. In the below requirements, the term 'element of the X column' refers to one cell of the Interface Descriptor Table at a certain row and column. In this way, the content of each cell of the Interface Descriptor Table is specified.

[SWS_SwCluC_00017]{DRAFT} [The rows in the Interface Descriptor Table shall be sorted in ascending order of resource type Ids and rows with equal resource type Ids shall be sorted in turn in ascending order of global resource Ids.](SRS_SwCluC_00001, SRS_SwCluC_00014)

[SWS_SwCluC_00018]{DRAFT} [The bit `SWCLUC_BMANIF_PROVIDED_RESOURCE` in the element of the 'resource properties' column shall be set, if the row belongs to a `SwCluC_BManif_ProvideResourceEntry`. Otherwise the bit `SWCLUC_BMANIF_PROVIDED_RESOURCE` shall not be set.](SRS_SwCluC_00001, SRS_SwCluC_00014)

[SWS_SwCluC_00019]{DRAFT} [The bit `SWCLUC_BMANIF_MANDATORY_RESOURCE` in the element of the 'resource properties' column shall be set, if the row belongs to a [SwCluCBManifRequireResourceEntry](#) where the `SwCluCBManifIsMandatory` is `true`. Otherwise the bit `SWCLUC_BMANIF_MANDATORY_RESOURCE` shall not be set.]([SRS_SwCluC_00001](#), [SRS_SwCluC_00014](#), [SRS_SwCluC_00009](#))

Please note that for [SwCluCBManifProvideResourceEntry](#)s the `SWCLUC_BMANIF_MANDATORY_RESOURCE` bit is always 0.

[SWS_SwCluC_00090] [The reserved bits 5 .. 0 in the element of the 'resource properties' column shall be set to 0]([SRS_SwCluC_00001](#), [SRS_SwCluC_00014](#))

[SWS_SwCluC_00020]{DRAFT} [The element in the 'resource type Id' column shall be set to the [SwCluCBManifResourceId](#) of the applicable [SwCluCBManifResourceType](#).]([SRS_SwCluC_00001](#), [SRS_SwCluC_00014](#))

Note: The applicable [SwCluCBManifResourceType](#) is referenced by the owning [SwCluCBManifProvideResourceEntryGroup](#) / [SwCluCBManifRequireResourceEntryGroup](#)

[SWS_SwCluC_00021]{DRAFT} [The element in the 'global resource Id' column shall be set to the attribute value [globalResourceId](#) of the referenced [CpSoftwareClusterResource](#) as given via [SwCluCBManifResourceRef](#). If the reference [SwCluCBManifResourceRef](#) is not set, the element in the global resource Id column shall be set to 0.]([SRS_SwCluC_00001](#), [SRS_SwCluC_00002](#), [SRS_SwCluC_00014](#))

[SWS_SwCluC_00022]{DRAFT} [The element in the 'guard value' column shall be set to the [SwCluCBManifResourceGuardValue](#) of the [SwCluCBManifProvideResourceEntry](#) / [SwCluCBManifRequireResourceEntry](#) container in the configuration.]([SRS_SwCluC_00001](#), [SRS_SwCluC_00010](#), [SRS_SwCluC_00014](#), [SRS_SwCluC_00205](#))

[SWS_SwCluC_00023]{DRAFT} [The element in the 'offered interface table index' column shall be set to the index of the [Offered Interface](#) where the first offered handle for this resource is allocated. In case the resource has no offered handle the value is set to `NO_TABLE_ENTRY`.]([SRS_SwCluC_00001](#), [SRS_SwCluC_00014](#))

[SWS_SwCluC_00024]{DRAFT} [The element in the 'number of handles in offered interface table' column shall be set to number of offered handles for this resource. In case the resource has no offered handle, the value is set to 0.]([SRS_SwCluC_00001](#), [SRS_SwCluC_00014](#), [SRS_SwCluC_00003](#))

[SWS_SwCluC_00025]{DRAFT} [The element in the 'subscribed interface table index' column shall be set to the index of the [Subscribed Interface](#) where the first subscribed handle for this resource is allocated. In case the resource has no subscribed handle the value is set to `NO_TABLE_ENTRY`.]([SRS_SwCluC_00001](#), [SRS_SwCluC_00014](#))

[SWS_SwCluC_00026]{DRAFT} [The element in the 'number of handles in subscribed interface table' column shall be set to number of subscribed handles for this

resource. In case the resource has no subscribed handle, the value is set to 0.]([SRS_SwCluC_00001](#), [SRS_SwCluC_00014](#), [SRS_SwCluC_00003](#))

[SWS_SwCluC_00027]{DRAFT} [The element in the 'number of handle sets in subscribed interface table' column shall be set to the [SwCluCBManifMaxNumberOfNotifierSets](#) if the applicable [SwCluCBManifResourceType](#) has set [SwCluCBManifMultipleNotifierSupport](#) to [MULTIPLE_NOTIFIER_SETS](#). Otherwise the value is set to 0.]([SRS_SwCluC_00001](#), [SRS_SwCluC_00014](#), [SRS_SwCluC_00004](#))

Depending whether a resource is provided or required by a [Software Cluster](#), the [Provide Handles](#) and [Notifier Handles](#) need to be put either in the [Offered Interface](#) or in the [Subscribed Interface](#). The table [7.1](#) defines, how many of the handles for a [SwCluCBManifProvideResourceEntry](#) / [SwCluCBManifRequireResourceEntry](#) are created in the [Offered Interface](#) or [Subscribed Interface](#).

[SWS_SwCluC_00088]{DRAFT} Number of offered and subscribed handles, depending on the resource direction [

	Provide Handle	Notifier Handle
Provided Resource	<p style="text-align: center;">One handle in the Offered Interface per defined SwCluCManifProvideHandle</p> <p>The handles are initialized with the SwCluCManifProvideSymbols in the given order.</p>	SINGLE_NOTIFIER_SET
		<p>One handle in the Subscribed Interface per defined SwCluCManifNotifierHandle</p> <p>The handles are initialized with the SwCluCManifDefaultNotifierSymbols in the given order.</p> <p>The Software Cluster Ids are set to SWCLUC_BMANIF_UNCONNECTED</p>
Required Resource	<p style="text-align: center;">One handle in the Subscribed Interface per defined SwCluCManifProvideHandle</p> <p>The handles are initialized with the SwCluCManifDefaultProvideSymbols in the given order.</p>	MULTIPLE_NOTIFIER_SETS
		<p>One handle in the Subscribed Interface per defined SwCluCManifNotifierHandle multiplied by SwCluCManifMaxNumberOfNotifierSets plus one</p> <p>The first handle is initialized to 0.</p> <p>The remaining handles are initialized with consecutive sets of SwCluCManifDefaultNotifierSymbols in the given order.</p> <p>The Software Cluster Ids are set to SWCLUC_BMANIF_UNCONNECTED.</p>
	<p style="text-align: center;">One handle in the Offered Interface per defined SwCluCManifNotifierHandle</p> <p>The handles are initialized with the SwCluCManifNotifierSymbols in the given order.</p>	

Table 7.1: Number of offered and subscribed handles, depending on the resource direction

]

7.1.4.5 Offered Interface Table

[SWS_SwCluC_00028]{DRAFT} [The [Binary Manifest](#) of the [Software Cluster Connection](#) shall provide exactly one instance of the [Offered Interface Handle Column](#)

```
1 const SwCluC_BManif_HandleType
   SwCluC_BManif_OfferedInterfaceHandleColumn[
   SWCLUC_BMANIF_NO_OF_OFFERED_HANDLES] = { <initialization> };
```

]([SRS_SwCluC_00001](#), [SRS_SwCluC_00014](#), [SRS_SwCluC_00011](#))

[SWS_SwCluC_00029]{DRAFT} [The [Binary Manifest](#) of the [Software Cluster Connection](#) shall allocate and initialize the number of handles in the [Offered Interface](#) according to [\[SWS_SwCluC_00088\]](#).]([SRS_SwCluC_00001](#), [SRS_SwCluC_00014](#), [SRS_SwCluC_00011](#), [SRS_SwCluC_00013](#))

7.1.4.6 Subscribed Interface Table

[SWS_SwCluC_00030]{DRAFT} [The [Binary Manifest](#) of the [Software Cluster Connection](#) shall provide exactly one instance of the [Subscribed Interface Default Handle Column](#)

```
1 const SwCluC_BManif_HandleType
   SwCluC_BManif_SubscribedInterfaceDefaultHandleColumn[
   SWCLUC_BMANIF_NO_OF_SUBSCRIBED_HANDLES] = { <initialization> };
```

]([SRS_SwCluC_00001](#), [SRS_SwCluC_00014](#), [SRS_SwCluC_00011](#), [SRS_SwCluC_00013](#), [SRS_SwCluC_00009](#))

[SWS_SwCluC_00031]{DRAFT} [The [Binary Manifest](#) of the [Software Cluster Connection](#) shall allocate and initialize the number of handles in the [Subscribed Interface Default Handle Column](#) according to [\[SWS_SwCluC_00088\]](#).]([SRS_SwCluC_00001](#), [SRS_SwCluC_00014](#), [SRS_SwCluC_00011](#), [SRS_SwCluC_00013](#))

[SWS_SwCluC_00032]{DRAFT} [The [Binary Manifest](#) of the [Software Cluster Connection](#) shall provide exactly one instance of the [Subscribed Interface Handle Column](#)

```
1 const SwCluC_BManif_HandleType
   SwCluC_BManif_SubscribedInterfaceHandleColumn[
   SWCLUC_BMANIF_NO_OF_SUBSCRIBED_HANDLES] = { <initialization> };
```

]([SRS_SwCluC_00001](#), [SRS_SwCluC_00014](#), [SRS_SwCluC_00011](#), [SRS_SwCluC_00013](#))

[SWS_SwCluC_00033]{DRAFT} [The [Binary Manifest](#) of the [Software Cluster Connection](#) shall allocate and initialize the number of handles in the [Subscribed Interface Handle Column](#) according to [\[SWS_SwCluC_00088\]](#).]

(SRS_SwCluC_00001, SRS_SwCluC_00014, SRS_SwCluC_00011, SRS_SwCluC_00013)

[SWS_SwCluC_00034]{DRAFT} [The Binary Manifest of the Software Cluster Connection shall provide exactly one instance of the Subscribed Interface Connected SwClusterId Column

```
1 const SwCluC_BManif_SwClusterIdType
    SwCluC_BManif_SubscribedInterfaceConnectedSwClusterIdColumn[
        SWCLUC_BMANIF_NO_OF_SUBSCRIBED_HANDLES] = { <initialization> };
```

](SRS_SwCluC_00001, SRS_SwCluC_00014, SRS_SwCluC_00011, SRS_SwCluC_00013, SRS_SwCluC_00009, SRS_SwCluC_00002)

[SWS_SwCluC_00035]{DRAFT} [The Binary Manifest of the Software Cluster Connection shall allocate and initialize the number of handles in the Subscribed Interface Connected SwClusterId Column according to [SWS_SwCluC_00088].](SRS_SwCluC_00001, SRS_SwCluC_00014, SRS_SwCluC_00011, SRS_SwCluC_00013, SRS_SwCluC_00009, SRS_SwCluC_00002)

7.1.4.7 Administrative Data

7.1.4.7.1 Immutable Tables Checksum

The Immutable Tables Checksum is built over all those constants of the Binary Manifest that are not changed by the Software Cluster connection step.

This includes

- the Binary Manifest Header
- all arrays of the Interface Descriptor Table
- all arrays of the Offered Interface
- the Subscribed Interface Default Handle Column

The checksum is created as part of the software build.

[SWS_SwCluC_00036]{DRAFT} [The Binary Manifest of the Software Cluster Connection shall provide exactly one instance of the Immutable Tables Checksum

```
1 const uint32 SwCluC_BManif_ImmutableTablesChecksum = <initialization>;
```

](SRS_SwCluC_00001, SRS_SwCluC_00014)

[SWS_SwCluC_00037]{DRAFT} [The Immutable Tables Checksum shall be set to the value of the configuration parameter SwCluCBManifImmutableTablesChecksum.](SRS_SwCluC_00001, SRS_SwCluC_00014)

[SWS_SwCluC_CONSTR_00073]{DRAFT} [The [Immutable Tables Checksum](#) shall be calculated on the binary representation in memory of the immutable memory area (inclusive reserved memory space) in ascending order of memory address as CRC32 according to 32-bit Ethernet CRC Calculation as described in document [16].] ([SRS_SwCluC_00001](#), [SRS_SwCluC_00014](#))

7.1.4.7.2 Subscribed Interface Validity Marker

The [Subscribed Interface Validity Marker](#) indicates that all subscribed tables are written after the Software Cluster connection step. It needs to be set to the valid value after the Software Cluster connection step. The invalid /valid values are not standardized, since those values need to be chosen according to the flash technology storing the [Binary Manifest](#).

[SWS_SwCluC_00040]{DRAFT} [The [Binary Manifest](#) of the [Software Cluster Connection](#) shall provide exactly one instance of the [Subscribed Interface Validity Marker](#)

```
1  const uint32 SwCluC_BManif_SubscribedInterfaceValidityMarker = <
    initialization>;
```

] ([SRS_SwCluC_00001](#), [SRS_SwCluC_00014](#))

[SWS_SwCluC_00041]{DRAFT} [Initially the [Subscribed Interface Validity Marker](#) shall be set to the value of the configuration parameter [SwCluC_BManif_SubscribedInterfaceValidityMarker](#).] ([SRS_SwCluC_00001](#), [SRS_SwCluC_00014](#))

[SWS_SwCluC_00095] [After a completed connection process, the [Subscribed Interface Validity Marker](#) shall be set to the value 0xFFA5A500.] ([SRS_SwCluC_00001](#), [SRS_SwCluC_00014](#))

7.1.4.8 Memory Mapping

[SWS_SwCluC_00079]{DRAFT} [The [Binary Manifest](#) of the [Software Cluster Connection](#) shall use the <feature> = `BMANIF` according to [\[SWS_MemMap_00040\]](#) of document [17].] ([SRS_SwCluC_00001](#), [SRS_SwCluC_00011](#), [SRS_SwCluC_00014](#))

[SWS_SwCluC_00080]{DRAFT} [The [Binary Manifest](#) of the [Software Cluster Connection](#) shall map the [Binary Manifest Header](#) to a constant, 32 bit aligned memory section named `CONST_IMMUTABLE_HEADER`.] ([SRS_SwCluC_00001](#), [SRS_SwCluC_00011](#), [SRS_SwCluC_00014](#))

Example 7.1

```
1  #define SWCLUC_BMANIF_START_SEC_CONST_IMMUTABLE_HEADER_32
2  #include "SwCluC_MemMap.h"
```

```

3
4 const SwCluC_BManif_HeaderType SwCluC_BManif_Header = ...;
5
6 #define SWCLUC_BMANIF_STOP_SEC_CONST_IMMUTABLE_HEADER_32
7 #include "SwCluC_MemMap.h"

```

[SWS_SwCluC_00081]{DRAFT} [The [Binary Manifest of the Software Cluster Connection](#) shall map the immutable columns of all tables to a constant, 32 bit aligned memory section named `CONST_IMMUTABLE_COLUMNS`. The immutable columns are:

- all columns of the [Interface Descriptor Table](#)
- [Offered Interface Handle Column](#)
- [Subscribed Interface Default Handle Column](#)

]([SRS_SwCluC_00001](#), [SRS_SwCluC_00011](#), [SRS_SwCluC_00014](#))

Example 7.2

```

1 #define SWCLUC_BMANIF_START_SEC_CONST_IMMUTABLE_COLUMNS_32
2 #include "SwCluC_MemMap.h"
3
4 const SwCluC_BManif_ResourcePropertiesType
   SwCluC_BManif_ResourcePropertiesDescriptorColumn[
   SWCLUC_BMANIF_NO_OF_DESCRIPTOR] = ...;
5
6 ...
7
8 const SwCluC_BManif_HandleType
   SwCluC_BManif_SubscribedInterfaceDefaultHandleColumn[
   SWCLUC_BMANIF_NO_OF_SUBSCRIBED_HANDLES] = ...;
9
10 #define SWCLUC_BMANIF_STOP_SEC_CONST_IMMUTABLE_COLUMNS_32
11 #include "SwCluC_MemMap.h"

```

[SWS_SwCluC_00082]{DRAFT} [The [Binary Manifest of the Software Cluster Connection](#) shall map the modifiable columns to a constant, 32 bit aligned memory section named `CONST_MODIFIABLE_COLUMNS`. The modifiable columns are

- [Subscribed Interface Handle Column](#)
- [Subscribed Interface Connected SwClusterId Column](#)

.)([SRS_SwCluC_00001](#), [SRS_SwCluC_00011](#), [SRS_SwCluC_00014](#))

Example 7.3

```

1 #define SWCLUC_BMANIF_START_SEC_CONST_MODIFIABLE_COLUMNS_32
2 #include "SwCluC_MemMap.h"
3

```

```
4  const SwCluC_BManif_HandleType
      SwCluC_BManif_SubscribedInterfaceHandleColumn[
      SWCLUC_BMANIF_NO_OF_SUBSCRIBED_HANDLES] = ...;
5
6  const SwCluC_BManif_SwClusterIdType
      SwCluC_BManif_SubscribedInterfaceConnectedSwClusterIdColumn[
      SWCLUC_BMANIF_NO_OF_SUBSCRIBED_HANDLES] = ...;
7
8  #define SWCLUC_BMANIF_STOP_SEC_CONST_MODIFIABLE_COLUMNS_32
9  #include "SwCluC_MemMap.h"
```

[SWS_SwCluC_00083]{DRAFT} [The [Binary Manifest of the Software Cluster Connection](#) shall map the [Immutable Tables Checksum](#) to a constant, 32 bit aligned memory section named `CONST_IMMUTABLE_TABLES_CHECKSUM`.] ([SRS_SwCluC_00001](#), [SRS_SwCluC_00011](#), [SRS_SwCluC_00014](#))

Rationale: Checksums handling in memory might need a fixed location.

Example 7.4

```
1  #define SWCLUC_BMANIF_START_SEC_CONST_IMMUTABLE_TABLES_CHECKSUM_32
2  #include "SwCluC_MemMap.h"
3
4  const uint32 SwCluC_BManif_ImmutableTablesChecksum = ...;
5
6  #define SWCLUC_BMANIF_STOP_SEC_CONST_IMMUTABLE_TABLES_CHECKSUM_32
7  #include "SwCluC_MemMap.h"
```

[SWS_SwCluC_00085]{DRAFT} [The [Binary Manifest of the Software Cluster Connection](#) shall map the [Subscribed Interface Validity Marker](#) to a constant, 32 bit aligned memory section named `CONST_SUBSCRIBED_INTERFACE_VALIDITY_MARKER`.] ([SRS_SwCluC_00001](#), [SRS_SwCluC_00011](#), [SRS_SwCluC_00014](#))

Rationale: Validity handling in memory might need a fixed location.

Example 7.5

```
1  #define SWCLUC_BMANIF_START_SEC_CONST_SUBSCRIBED_TABLES_MARKER_32
2  #include "SwCluC_MemMap.h"
3
4  const uint32 SwCluC_BManif_SubscribedInterfaceValidityMarker = ...;
5
6  #define SWCLUC_BMANIF_STOP_SEC_CONST_SUBSCRIBED_TABLES_MARKER_32
7  #include "SwCluC_MemMap.h"
```

7.1.5 Connecting Software Clusters

7.1.5.1 Overview

The AUTOSAR Methodology supports two different approaches to connect the [Binary Objects](#) of the different [Software Clusters](#).

- The [Software Clusters](#) are connected after the individual and unconnected [Binary Objects](#) are programmed on the target ECU, here called [On-board](#).
- The [Software Clusters](#) are connected before the [Binary Objects](#) are programmed on the target ECU outside the target [machine](#), here called [Off-board](#).

In the [On-board](#) case, the [On-board Software Cluster Connector](#) is a software, which is executed on the target ECU during the reprogramming phase. After reprogramming one or more unconnected [Binary Objects](#), the [Software Cluster Connector](#) stores the connection result into the modifiable area of the [Subscribed Interface](#) of the [Binary Manifest](#).

Please note: The design of the [Binary Manifest](#) assumes that a connection phase might get aborted at any point in time (e.g. power loss), and a restart or recovery of the connection phase should be supported.

In the [Off-board](#) case, the [Off-board Software Cluster Connector](#) is a tool, which is used to read the files of the [Binary Objects](#), and to store the result of the connection in files. When reprogramming the ECU, already connected [Binary Objects](#) are used. Such an [Off-board](#) process supports additionally the variant to store meta data contained in the [Interface Descriptor Table](#) outside the [Binary Objects](#), with the benefit that no ROM for this meta data is occupied.

Most requirements given in the section are kept universal, and can be applied for the [On-board](#) and [Off-board](#) case. If requirements are specific to one case, this is indicated in the requirement. Since AUTOSAR does not standardize the architecture of a flash boot loader, no further interfaces for the [On-board Software Cluster Connector](#) are standardized.

Some general remarks on [machines](#):

Direct connections between [Software Clusters](#) based on the [Binary Manifest](#) are only made locally (on the same machine). Connecting [Software Clusters](#) across 'virtual' machines on the same micro controller is not possible, as it would break the separation between the virtual machines.

7.1.5.2 Connecting Resources

[SWS_SwCluC_00043]{DRAFT} [The [Software Cluster Connector](#) shall connect a required resource with a provided resource, if all of the following conditions are fulfilled:

- the machine Id of the `Software Cluster` providing the resource and the machine Id of the `Software Cluster`(s) requesting the resource are identical
- the global resource Id of provided resource and required resource(s) are equal
- the global resource Id is not 0
- the resource type Id of provided resource and required resource is equal
- the guard value of provided resource and required resource is equal
- the number of `Provide Handles` of provided resource and required resource is equal
- the number of `Notifier Handles` of provided resource and required resource is equal
- in case `Notifier Handles` exist, the provided resource has a `Notifier Handle Sets` available for the required resource

]([SRS_SwCluC_00002](#), [SRS_SwCluC_00205](#))

Note: The global resource Id = 0 is reserved to indicate the absence of a valid Id. The `Software Cluster Connector` shall only connect if the global resource Id != 0.

7.1.5.3 Handling of the `Substitution Software Cluster`

The purpose of the `Substitution Software Cluster` is to temporarily overwrite the output of a `Software Cluster` for development purposes. For instance, if a sender receiver signal 'Y' of `Software Cluster A` does not have the right functional behavior, it is possible to add a `Substitution Software Cluster` which provides a fixed version of sender receiver signal 'Y'. The fixed version of sender receiver signal 'Y' is provided with the identical global resource Id. In such a case, all `Software Clusters` requiring the sender receiver signal 'Y' are getting connected to the `Substitution Software Cluster` instead of the original providing `Software Cluster`. If the `Substitution Software Cluster` additionally requires the sender receiver signal 'Y', it gets connected to the original providing `Software Cluster`. With this principle, it is possible to take the original version of the signal as a basis for the overwriting one.

The utilization of a `Substitution Software Cluster` is only intended for development purposes, and not supported in productive systems. It is intended as a quick means for problem solving during development (for example, if a signal that is provided by a third party needs to be modified). At a `machine`, at most one `Substitution Software Cluster` is supported to avoid ambiguity about the effective resource provider.

[[SWS_SwCluC_CONSTR_00087](#)]{DRAFT} [At a `machine`, at most one `Substitution Software Cluster` shall exist.]([SRS_SwCluC_00005](#))

[SWS_SwCluC_00054]{DRAFT} [In case a resource is provided by the *Substitution Software Cluster*, the *Software Cluster Connector* shall connect all *Software Clusters* requiring the resource, except the *Substitution Software Cluster* itself, to the resource of the *Substitution Software Cluster*. This happens, regardless if another *Software Cluster* provides the resource as well. Nevertheless, the matching criteria defined in **[SWS_SwCluC_00043]** apply.](*SRS_SwCluC_00005*)

[SWS_SwCluC_00055]{DRAFT} [In case a resource is required by a *Substitution Software Cluster*, the *Software Cluster Connector* shall connect this required resource only to provided resources of *Software Clusters* not being a *Substitution Software Cluster*. Nevertheless, the matching criteria defined in **[SWS_SwCluC_00043]** apply.](*SRS_SwCluC_00005*)

7.1.5.4 Multiple Notifier Sets

Note: A provided resource can optionally have the ability to handle multiple notifier sets. In this case, the number of handle sets in the *Interface Descriptor Table* indicates how many handle sets the *Software Cluster Connector* can register at most. The first handle in the *Subscribed Interface Handle Column* provides the number of actual registered *Notifier Handle Sets*. The subsequent handles in the *Subscribed Interface Handle Column* are store N sets of handles in a consecutive order. The order of the different handle sets written by the *Software Cluster Connector* are determined by the *Software Cluster Id*.

[SWS_SwCluC_00045]{DRAFT} [In case the provided resource supports multiple *Notifier Handle Sets*, the *Software Cluster Connector* shall sort the *Notifier Handle Sets* in ascending order of *Software Cluster Id* of the according required resource(s), and place them in the *Subscribed Interface Handle Column* of the providing *Software Cluster*, starting at the second handle.](*SRS_SwCluC_00004*)

[SWS_SwCluC_00046]{DRAFT} [In case the provided resource supports multiple *Notifier Handle Sets*, the *Software Cluster Connector* shall write as first entry the actual number of used *Notifier Handle Sets* in the *Subscribed Interface Handle Column*.](*SRS_SwCluC_00004*)

Note: the actual number of used *Notifier Handle Sets* is equal to the actual number of connected required resources, since each resource occupies one *Notifier Handle Set*.

[SWS_SwCluC_00089]{DRAFT} [In case the provided resource supports multiple *Notifier Handle Sets*, the *Software Cluster Connector* shall write as first entry in the *Subscribed Interface Connected SwClusterId Column* the value 0xFE.](*SRS_SwCluC_00004*)

Note: the value 0xFE indicates that the corresponding cell in the *Subscribed Interface Handle Column* holds the actual number of used notifier sets.

[SWS_SwCluC_00047]{DRAFT} [In case the provide resource supports multiple [Notifier Handle Sets](#), and less required resources are connected, the Software Cluster Connector shall fill the remaining handles in the [Subscribed Interface Handle Column](#) with the default values from the [Subscribed Interface Default Handle Column](#) of the [Software Cluster](#) providing the resource.] ([SRS_SwCluC_00004](#))

The example in table 7.2 shows a connection of a resource provider offering at most 4 [Notifier Handle](#) sets. The resource type uses two [Notifier Handles](#). The provided resource is connected to two different [Software Clusters](#), and the remaining two [Notifier Handle](#) sets are filled with defaults.

Subscribed Interface Handle Column	Subscribed Interface Connected SwClusterId Column	remark
2	0xFE	actual number of used notifier sets, entry in Subscribed Interface Connected SwClusterId Column is set to 0
0xABCDABCD	2	first handle of required resource in Software Cluster 2
0xABC04711	2	second handle of required resource in Software Cluster 2
0xDADA0010	5	first handle of required resource in Software Cluster 5
0xDADA0020	5	second handle of required resource in Software Cluster 5
0xC0CAC01A	0xFF	first default handle of resource provider, entry in Subscribed Interface Connected SwClusterId Column is set to SWCLUC_BMANIF_UNCONNECTED
0xADD511FE	0xFF	second default handle of resource provider, entry in Subscribed Interface Connected SwClusterId Column is set to SWCLUC_BMANIF_UNCONNECTED
0xC0CAC01A	0xFF	first default handle of resource provider, entry in Subscribed Interface Connected SwClusterId Column is set to SWCLUC_BMANIF_UNCONNECTED
0xADD511FE	0xFF	second default handle of resource provider, entry in Subscribed Interface Connected SwClusterId Column is set to SWCLUC_BMANIF_UNCONNECTED

Table 7.2: Example of multiple notifier set connection

7.1.5.5 Unconnected Resources

[SWS_SwCluC_00044]{DRAFT} [The Software Cluster Connector shall copy the [Subscribed Interface Default Handle Column](#) entries to the [Subscribed Interface Handle Column](#), and set the related entries in the [Subscribed Interface Connected SwClusterId Column](#) to SWCLUC_BMANIF_UNCONNECTED for

- all [Provide Handles](#) of any required resources, for which no connect was applied
- AND
- all [Notifier Handles](#) of any provided resources, for which no connect was applied

](SRS_SwCluC_00009)

7.1.5.6 Disabling of the On-board Software Cluster Connection

In general, it is possible that an ECU is equipped with an [On-board Software Cluster Connector](#) but this connector should not be used or shall only be used on specific [machines](#).

One reason to do so is a configuration where the software on one [machine](#) requires a certification applied on the whole [machine](#)'s software whereas the software on the other [machine](#) can be updated cluster-wise.

For example, such a configuration uses two [machines](#) on the same microcontroller, here called `Machine A` and `Machine B`.

`Machine A` needs a certification, which is only granted for the whole software on the [machine](#). Nevertheless, the software is developed by multiple parties, with the means of [Software Clusters](#). The [Software Clusters](#) still needs to be connected, which is done with the [Off-board Software Cluster Connector](#) before the certification is done.

For `Machine B`, this restriction does not apply. Here, the [On-board Software Cluster Connector](#) shall be used to do some in-field partial updates which requires a working [On-board Software Cluster Connector](#). Since the flash-boot-loader for the whole microcontroller still has to work, the [On-board Software Cluster Connector](#) is disabled for `Machine A`, in order to protect it from unintended changes, caused by an [On-board Software Cluster Connector](#) run intended for `Machine B`.

[SWS_SwCluC_00056]{DRAFT} [If the bit `SWCLUC_BMANIF_DISABLE_ON_ECU_CONNECTION` in the `ConnectorControlFlags` of the [Binary Manifest Header](#) of the [Host Software Cluster](#) is set, the [Software Cluster Connection On-board](#) for this [machine](#) is not executed.]()

7.1.5.7 Errors during software cluster connection

In some cases, the information inside the [Binary Manifests](#) might be incompatible with the cluster connector, be incomplete or inconsistent. For example, reading a [Binary Manifest](#), which is structurally incompatible to the [Software Cluster Connector](#)'s implementation, may have completely undefined results. This section lists a set of conditions that lead to an abort of the connection process.

The behavior of the system after an abort is currently not specified. The implementation of recovery mechanisms is advisable.

[SWS_SwCluC_00048]{DRAFT} [The [Software Cluster Connector](#) shall detect, if the `ManifestMajorVersion` and `ManifestMinorVersion` numbers given

in the [Binary Manifest Header](#) are compatible to the Software Cluster Connector's implementation. In case of any incompatible version number, the connection process for this specific [machine](#) shall be aborted.]()

If the Software Cluster Ids are not unique on the same [machine](#), the [Subscribed Interface Connected SwClusterId Column](#) cannot be set unambiguously:

[SWS_SwCluC_00049]{DRAFT} [The Software Cluster Connector shall detect, if the Software Cluster Ids of all [Software Clusters](#) belonging to same [machine](#) are not unique. In this case, the connection process for this specific [machine](#) shall be aborted.]()

If a [Software Cluster](#) requires a mandatory resource that no other [Software Cluster](#) provides, the operation of the [Software Cluster](#) is not possible.

[SWS_SwCluC_00050]{DRAFT} [The Software Cluster Connector shall detect, if for a [Software Cluster](#) any mandatory required resource is not provided by any other [Software Cluster](#). In this case, the connection process for this specific [Software Cluster](#) shall be aborted.]()

In general, a resource shall only be provided once. The only exception is a second provision by the [Substitution Software Cluster](#), which overrides the provision by another [Software Cluster](#).

[SWS_SwCluC_00051]{DRAFT} [The Software Cluster Connector shall detect, if for a [machine](#) a resource with the identical resource type id and identical global resource Id is provided twice by [Software Clusters](#), none of which is a [Substitution Software Cluster](#). In this case, the connection process for this specific [machine](#) shall be aborted.]()

[SWS_SwCluC_00052]{DRAFT} [In case the resource does not support multiple notifier sets, but uses [Notifier Handles](#), the Software Cluster Connector shall detect if for a [machine](#) a resource with the identical resource type id and identical global resource Id is required more than one time. In this case, the connection process for this specific [machine](#) shall be aborted.]()

[SWS_SwCluC_00053]{DRAFT} [In case the resource does support multiple notifier sets, the Software Cluster Connector shall detect if for a [machine](#) a resource with the identical resource type id and identical global resource Id is required more often as notifier sets are available. In this case, the connection process for this specific [machine](#) shall be aborted.]()

7.1.6 Software Cluster Binary Manifest Descriptor

The Software Cluster Binary Manifest Descriptor describes the [Binary Manifest](#) in the [Binary Object](#). This is mandatory for [Off-board](#) connection, but also supporting the [On-board](#) connection, since it enables to apply checks outside the target ECU.

[SWS_SwCluC_00086]{DRAFT} [The [Binary Manifest](#) of the [Software Cluster Connection](#) shall provide one instance of the [CpSoftwareClusterBinaryManifestDescriptor](#), which holds the description of the generated [Binary Manifest](#). This includes

- the [cpSoftwareCluster](#) reference to the given [CpSoftwareCluster](#)
- the [softwareClusterId](#) of the given [CpSoftwareCluster](#)
- the [metaDataFields](#) for `IMMUTABLE_TABLES_CHECKSUM` and `SUBSCRIBED_INTERFACE_VALIDITY_MARKER`
- a [provideResources](#) for each [Provide Resource Entry](#)
- a [requireResources](#) for each [Require Resource Entry](#)
- a [resourceDefinitions](#) for each [Resource Type](#)

]()

7.1.7 Error Classification

On source code level, the implementation of the [Binary Manifest](#) is a set of constant tables accessible with a set of C-Macros. Those in turn need to be capable to be static C-initializers. Since the constant tables cannot change at runtime, any implementation of run-time detecting error code is not useful. Therefore, the following sections do not define error codes, and are marked as not applicable.

7.1.7.1 Development Errors

Development errors are not applicable for the [Binary Manifest](#) of the [Software Cluster Connection](#).

7.1.7.2 Runtime Errors

Runtime errors are not applicable for the [Binary Manifest](#) of the [Software Cluster Connection](#).

7.1.7.3 Transient Faults

Transient Faults are not applicable for the [Binary Manifest](#) of the [Software Cluster Connection](#).

7.1.7.4 Production Errors

Production Errors are not applicable for the [Binary Manifest](#) of the [Software Cluster Connection](#).

7.1.7.5 Extended Production Errors

Extended Production Errors are not applicable for the [Binary Manifest](#) of the [Software Cluster Connection](#).

7.2 Software Cluster Base Configuration Check

The [Software Cluster Base Configuration Check](#) provides a basic mechanism, to avoid that [Application Software Clusters](#) with severe configuration incompatibilities are connected to the [Host Software Cluster](#). This mechanism utilizes the guard value and mandatory feature of the [Binary Manifest](#). The configuration information collected in the two parameters [SwCluCAutoBaseConfigDescriptor](#) and [SwCluCUserBaseConfigDescriptor](#) is used to calculate the guard value for a mandatory connection.

In case of deviating configurations in the [Host Software Cluster](#) and [Application Software Cluster](#), the connection fails. In this case, the whole [Application Software Cluster](#) stays unconnected, and is skipped in the connection process (treated, as if it was not present). Please note as well [[SWS_SwCluC_00050](#)].

It is implementation dependent, which configuration settings are automatically collected into the [SwCluCAutoBaseConfigDescriptor](#). But it is strongly recommended, to consider only those ECU / [machine](#) wide settings that are functional critical, in order to avoid frequent incompatibilities. For instance, compiler settings impacting the EAIB compatibility, like fill byte usage, stack usage, machine register usage.

[[SWS_SwCluC_00075](#)]{DRAFT} [In the [Host Software Cluster](#), the [Software Cluster Base Configuration Check](#) of the [Software Cluster Connection](#) shall create one [Provide Resource Entry](#) for each configured [SwCluCBaseConfigurationCheck](#), and add it to the [Binary Manifest](#).]()

[[SWS_SwCluC_00076](#)]{DRAFT} [In the [Application Software Cluster](#), the [Software Cluster Base Configuration Check](#) of the [Software Cluster Connection](#) shall create one **mandatory** [Require Resource Entry](#) for each configured [SwCluCBaseConfigurationCheck](#), and add them to the [Binary Manifest](#).]()

[[SWS_SwCluC_00077](#)]{DRAFT} [The [SwCluCBManifResourceGuardValue](#) of the [Resource Entries](#) of [[SWS_SwCluC_00075](#)] and [[SWS_SwCluC_00076](#)] shall be calculated out of the given multi line strings in [SwCluCAutoBaseConfigDescriptor](#) and [SwCluCUserBaseConfigDescriptor](#).]([SRS_SwCluC_00205](#))

7.3 Cross Cluster Communication

7.3.1 Overview

The [Cross Cluster Communication](#) implements the VFB communication between [Software Clusters](#). For this purpose, the [Cross Cluster Communication](#) implements a [Cross Software Cluster Communication Plug-In](#), as specified in document [4].

Due to the intended separation of [Software Clusters](#) (e.g. well separated build units, independent timing), some VFB communication features would either become very inefficient or would break the intended separation. Hence, this specification selected a subset of the most common VFB features expected for such systems, as explained in document [1].

Those are in brief:

- 1:n last is the best sender-receiver communication
- n:1 queued sender-receiver communication
- n:1 client server communication - asynchronous server calls only
- 1:n mode switch communication
- 1:n parameter communication
- limited applicability of [PortInterfaceMappings](#), see [7.3.2.2](#)
- [DataReceivedEvents](#) are polled
- [AsynchronousServerCallReturnsEvent](#) are polled
- [OperationInvokedEvents](#) for [Cross Cluster Communication](#) calls are polled

When designing an implementation of a [Cross Cluster Communication](#), this intended separation has to be considered. Since each [Software Clusters](#) is built by its own, only a limited knowledge about the other [Software Clusters](#) is in place. It is also not the target of this [Cross Cluster Communication](#) to break the goal of independent development of [Software Clusters](#) by exchange of detailed [Software Clusters](#) internal design and configuration information.

Instead, the code design patterns have to deal with limited knowledge about the communication counter part.

Due to the limited knowledge about the communication partner, the execution of code might fail in partitioned systems.

[SWS_SwCluC_CONSTR_03066]{DRAFT} [The implementation of a [Cross Cluster Communication](#) of an [Application Software Clusters](#) shall not execute code belonging to any other [Software Cluster](#), except from special entry

points provided by the [Host Software Cluster](#) (e.g. to implement event passing)] ([SRS_SwCluC_00100](#))

For this reason, [SynchronousServerCallPoints](#) are not supported for [Cross Cluster Communication](#). Please note as well [SWS_Rte_72023] in document [4].

In addition, inside a partitioned system it is not guaranteed that the RAM is writable for each [Software Cluster](#) or any given partition of a [Software Cluster](#).

[SWS_SwCluC_CONSTR_03067]{DRAFT} [The implementation of a [Cross Cluster Communication](#) of an [Application Software Cluster](#) shall only write into the memory of other [Software Clusters](#), if that write does not cross a Partition border. To determine this, the [Application Software Cluster](#) needs to determine if the [CpSoftwareClusterResource](#) is assigned to the same partition.] ([SRS_SwCluC_00100](#))

Please note: It might be required to restrict some communication patterns to intra-partition communication, for example to reach a certain performance. But this decreases the overall flexibility in the design and integration of [Software Clusters](#), and therefore should only be done in rare, exceptional cases.

7.3.2 General Requirements

7.3.2.1 Cross Software Cluster Communication Plug-In

[SWS_SwCluC_03000]{DRAFT} [The [Cross Cluster Communication](#) of the [Software Cluster Connection](#) shall implement a [Cross Software Cluster Communication Plug-In](#) according to document [4].] ([SRS_SwCluC_00100](#))

[[SWS_SwCluC_03000](#)] means among other things:

[SWS_SwCluC_03001]{DRAFT} [The [Vendor Specific Module Definition](#) (see document [18]) of the [Software Cluster Connection](#) shall provide a definition of the container [RteRipsPluginProps](#) as a [subContainer](#) of the container [SwCluCXcc](#) with the [shortName](#) [RteRipsPluginProps](#).] ([SRS_SwCluC_00100](#))

Please note that the [shortName](#) of the [EcucContainerValue](#) related to the [RteRipsPluginProps](#) container can be freely chosen. This name will be used to determine the name part <PlugIn> in the [RTE Implementation Plug-In Services](#) according to [SWS_Rte_70034].

[SWS_SwCluC_CONSTR_03069]{DRAFT} [The [EcucModuleConfigurationValues](#) of the [SwCluC](#) module shall set the [RteRipsPluginCommunicationScope](#) to [RTE_RIPS_CROSS_SW_CLUSTER_COM](#).] ([SRS_SwCluC_00100](#))

Note: It is possible to use multiple [Cross Software Cluster Communication Plug-Ins](#) in one [Software Cluster](#), but this might be rarely used in practice.

Additionally, the [Cross Cluster Communication](#) of the [Software Cluster Connection](#) has to provide all the [RTE Implementation Plug-In Services](#) according to the given input configuration.

[SWS_SwCluC_03002]{DRAFT} [The [Cross Cluster Communication](#) of the [Software Cluster Connection](#) shall implement the [RTE Implementation Plug-In](#) functionality for a [Communication Graph](#), if

- a [FlatInstanceDescriptor](#) references the [Communication Graph](#)

AND

- and the [rtePluginProps.associatedCrossSwClusterComRtePlugin](#) references the [RteRipsPluginProps](#) container of **this** [Cross Cluster Communication](#) implementation.

]([SRS_SwCluC_00100](#))

7.3.2.2 Cross Cluster Communication and Binary Manifest

[SWS_SwCluC_03003]{DRAFT} [The [Cross Cluster Communication](#) of the [Software Cluster Connection](#) shall put one [Resource Entry](#) for each associated [Communication Graph](#) into the [Binary Manifest](#).]([SRS_SwCluC_00100](#))

[SWS_SwCluC_03004]{DRAFT} [The [SwCluCBManifResourceRef](#) of the [Resource Entry](#) shall reference the [CpSoftwareClusterCommunicationResource](#) which is mapped by the [PortElementToCommunicationResourceMapping](#) to the [Communication Graph](#).]([SRS_SwCluC_00100](#))

[SWS_SwCluC_03005]{DRAFT} [The [SwCluCBManifResourceGuardValue](#) of the [Resource Entry](#) shall be calculated out of the following properties:

- data range
- resolution
- physical meaning
- encoding
- structure in memory

]([SRS_SwCluC_00010](#), [SRS_SwCluC_00205](#))

[SWS_SwCluC_03033]{DRAFT} [The [Cross Cluster Communication](#) of the [Software Cluster Connection](#) shall normalize the numerical values of attributes, before using them for the [SwCluCBManifResourceGuardValue](#) calculation, in such a way that compatible numerical values according to [TPS_GST_02501] result in the identical guard value.]([SRS_SwCluC_00010](#), [SRS_SwCluC_00205](#))

Note: **[SWS_SwCluC_03033]** shall ensure that the calculated guard value result is independent from the number format (e.g. decimal, binary, octal and hexadecimal)

of the given attributes. For instance the values, 1, 1.0, 0x000001 are semantically equivalent, and have to result in the identical guard value contribution.

Additionally, the below requirements on the guard value calculation in some cases define default values for optional existing attributes. This ensures an identical guard value on provider an requester side, even if one side expresses the default value explicitly and the other side omits it.

Only in special cases, the `shortName` of AUTOSAR model elements has an explicit semantic. Hence, `shortNames` are not relevant for the guard value, except if it is explicitly specified.

The list of attributes relevant for the guard value, specified in the following requirements, guarantee that different implementations of `Software Cluster Connections` treat the same set of required and provided ports as compatible, if these conditions apply:

- the elements in the `PortInterfaces` are compatible according to document [19] without `PortInterfaceMappings`
- or if a `PortInterfaceMappings` would be applied, it does not result in
 - Data Scaling
NOR
 - utilization of a `SubElementMapping`
NOR
 - utilization of a `ClientServerOperationMapping`
NOR
 - utilization of a `ClientServerApplicationErrorMapping`
NOR
 - utilization of a `ModeDeclarationMappingSet`

Please note:

In case the following requirements about guard value calculation list references as attributes, the calculation has to consider the attributes of the referenced model element. The fully qualified `shortName` (building the reference) is not part of the guard value. For example, the attribute `requiredInterface` is a reference to a `PortInterface`. In this case, the mentioned attributes of the referenced `PortInterface` are relevant instead of the fully qualified `shortName` (e.g. `/Example/PortInterfaces/MyS-RInterface`)

7.3.2.2.1 Guard value calculation for Data Communication Graphs

[SWS_SwCluC_03034]{DRAFT} [The Cross Cluster Communication shall use the following attributes for the SwCluCBManifResourceGuardValue calculation for a Data Communication Graph:

- PPortPrototype.providedInterface
- RPortPrototype.requiredInterface
- CpSoftwareClusterCommunicationResource.communicationResourceProps.sendIndication
 - in case of SenderReceiverInterface
 - * VariableDataPrototype.type
 - * VariableDataPrototype.swDataDefProps
 - * SenderReceiverInterface.invalidationPolicy.handleInvalid (if existing for the VariableDataPrototype, else dontInvalidate applies)
 - in case of ParameterInterface
 - * ParameterDataPrototype.type
 - * ParameterDataPrototype.swDataDefProps

Additionally, attributes of VariableDataPrototype / ParameterDataPrototype.type according to [SWS_SwCluC_03035] and [SWS_SwCluC_03036] apply.

](SRS_SwCluC_00010, SRS_SwCluC_00101, SRS_SwCluC_00102, SRS_SwCluC_00106, SRS_SwCluC_00205)

7.3.2.2.2 Guard value calculation for Client Server Communication Graphs

[SWS_SwCluC_03047]{DRAFT} [The Cross Cluster Communication shall use the following attributes for the SwCluCBManifResourceGuardValue calculation for a Client Server Communication Graph:

- PPortPrototype.providedInterface
- RPortPrototype.requiredInterface
 - ClientServerOperation.arguments {ordered}
 - * ArgumentDataPrototype.type
 - * ArgumentDataPrototype.direction

- `ClientServerOperation.possibleError.errorCode` (if existing, else one `errorCode = 0` is applied)

Additionally, attributes of `ArgumentDataPrototype.type` according to [SWS_SwCluC_03035] and [SWS_SwCluC_03036] apply.

](SRS_SwCluC_00010, SRS_SwCluC_00103, SRS_SwCluC_00205)

7.3.2.2.3 Guard value calculation for Mode Communication Graphs

[SWS_SwCluC_03045]{DRAFT} [The `Cross Cluster Communication` shall use the following attributes for the `SwCluCManifResourceGuardValue` calculation for a `Mode Communication Graph`:

- `PPortPrototype.providedInterface`
- `RPortPrototype.requiredInterface`
- `ModeDeclarationGroupPrototype.type`
- `ModeDeclarationGroup.category`
- `ModeDeclarationGroup.initialMode`
- `ModeDeclarationGroup.modeDeclarations`
- `ModeDeclarationGroup.onTransitionValue` (in case `ModeDeclarationGroup.category == EXPLICIT_ORDER`)
- `ModeDeclarationGroup.modeUserErrorBehavior` (if existing)
- `ModeDeclarationGroup.modeManagerErrorBehavior` (if existing)
- `ModeDeclarationGroup.modeTransitions` (if existing) for each `ModeDeclaration` the following attributes apply:
 - `ModeDeclaration.shortName`
 - `ModeDeclaration.value` (in case `ModeDeclarationGroup.category == EXPLICIT_ORDER`)

for each `ModeErrorBehavior` the following attributes apply:

- `ModeErrorBehavior.errorReactionPolicy`
- `ModeErrorBehavior.defaultMode` (if existing)

for each `ModeTransition` the following attributes apply:

- `ModeTransition.exitedMode`
- `ModeTransition.enteredMode`

](SRS_SwCluC_00010, SRS_SwCluC_00104, SRS_SwCluC_00205)

7.3.2.2.4 Guard value calculation for Trigger Communication Graphs

[SWS_SwCluC_03046]{DRAFT} [The [Cross Cluster Communication](#) shall use the following attributes for the [SwCluCBManifResourceGuardValue](#) calculation for a [Trigger Communication Graph](#):

- [PPortPrototype.providedInterface](#)
- [RPortPrototype.requiredInterface](#)
- [Trigger.swImplPolicy](#) (if existing, else [standard](#) applies)

]([SRS_SwCluC_00010](#), [SRS_SwCluC_00105](#), [SRS_SwCluC_00205](#))

7.3.2.2.5 Guard value calculation for DataPrototypes

[SWS_SwCluC_03035]{DRAFT} [The [Cross Cluster Communication](#) shall use the following attributes for the referenced [ApplicationDataType](#) for the [SwCluCBManifResourceGuardValue](#) calculation:

- in case the [AutosarDataPrototype.type](#) refers to a [ApplicationPrimitiveDataType](#)
 - [ApplicationPrimitiveDataType.category](#)
 - [ApplicationPrimitiveDataType.swDataDefProps](#)
- in case the [AutosarDataPrototype.type](#) refers to a [ApplicationArrayDataType](#)
 - [ApplicationArrayDataType.dynamicArraySizeProfile](#) (if existing)
 - [ApplicationArrayDataType.element](#)
 - [ApplicationArrayElement.type](#)
 - [ApplicationArrayElement.arraySizeSemantics](#) (if existing, else [fixedSize](#) applies)
 - [ApplicationArrayElement.arraySizeHandling](#) (if existing)
 - [ApplicationArrayElement.maxNumberOfElements](#)
- in case the [AutosarDataPrototype.type](#) refers to a [ApplicationRecordDataType](#)
 - [ApplicationRecordDataType.elements](#) {ordered}
 - [ApplicationRecordElement.type](#)
 - [ApplicationRecordElement.isOptional](#) (if existing, else [false](#) applies)

Additionally, the attributes of the mapped `ImplementationDataType` according to [SWS_SwCluC_03036] and the attributes of `SwDataDefProps` according to [SWS_SwCluC_03037] apply. (SRS_SwCluC_00010, SRS_SwCluC_00101, SRS_SwCluC_00102, SRS_SwCluC_00103, SRS_SwCluC_00106, SRS_SwCluC_00205)

[SWS_SwCluC_03036]{DRAFT} [The Cross Cluster Communication shall use the following attributes for the referenced or mapped `ImplementationDataType` for the `SwCluCManifResourceGuardValue` calculation:

- in case the `AutosarDataPrototype.type` refers to an `ImplementationDataType` of category `TYPE_REFERENCE` or the `ApplicationDataType` according to [SWS_SwCluC_03036] is mapped to an `ImplementationDataType` of category `TYPE_REFERENCE`
 - `ImplementationDataType.swDataDefProps`
- in case the `AutosarDataPrototype.type` refers to an `ImplementationDataType` of category `VALUE` or the `ApplicationDataType` according to [SWS_SwCluC_03036] is mapped to an `ImplementationDataType` of category `VALUE`
 - `ImplementationDataType.swDataDefProps`
- in case the `AutosarDataPrototype.type` refers to an `ImplementationDataType` of category `ARRAY` or the `ApplicationDataType` according to [SWS_SwCluC_03036] is mapped to an `ImplementationDataType` of category `ARRAY`
 - `ImplementationDataType.dynamicArraySizeProfile` (if existing)
 - `ImplementationDataType.swDataDefProps`
 - `ImplementationDataType.subElement`
 - `ImplementationDataTypeElement.arraySizeSemantics` (if existing, else `fixedSize` applies)
 - `ImplementationDataTypeElement.arraySizeHandling` (if existing)
 - `ImplementationDataTypeElement.swDataDefProps`
- in case `AutosarDataPrototype.type` refers to an `ImplementationDataType` of category `STRUCTURE` or the `ApplicationDataType` according to [SWS_SwCluC_03036] is mapped to an `ImplementationDataType` of category `STRUCTURE`
 - `ImplementationDataType.swDataDefProps`
 - `ImplementationDataType.isStructWithOptionalElement` (if existing, else `false` applies)
 - `ImplementationDataType.subElement` {ordered}

- `ImplementationDataTypeElement.arraySizeSemantics` (if existing, else `fixedSize` applies)
- `ImplementationDataTypeElement.arraySizeHandling` (if existing)
- `ImplementationDataTypeElement.swDataDefProps`

Additionally, the attributes of `SwDataDefProps` according to [SWS_SwCluC_03037] apply.

|(SRS_SwCluC_00010, SRS_SwCluC_00101, SRS_SwCluC_00102, SRS_SwCluC_00103, SRS_SwCluC_00106, SRS_SwCluC_00205)

[SWS_SwCluC_03037]{DRAFT} [The Cross Cluster Communication shall use the following attributes for the given `SwDataDefProps` for the `SwCluCBManifResourceGuardValue` calculation:

- `SwDataDefProps.additionalNativeTypeQualifier` (if existing)
- `SwDataDefProps.swImplPolicy` (if existing, else `standard` applies)
- `SwDataDefProps.invalidValue` (if existing)
- `SwDataDefProps.unit` (if existing, else `CompuMethod.unit` applies)
- `SwDataDefProps.dataConstr` (if existing)
- `SwDataDefProps.compuMethod` (if existing)
- `SwDataDefProps.swTextProps` (if existing)
- `SwDataDefProps.baseType` (if existing)
- `SwDataDefProps.swValueBlockSize` (if existing)
- `SwDataDefProps.swValueBlockSizeMult` (if existing)
- `SwDataDefProps.valueAxisDataType` (if existing)
- `SwDataDefProps.implementationDataType` (if existing)

Here, the prioritization of `SwDataDefProps` attributes according to [constr_1015] applies. Only the most prior `SwDataDefProps` attributes are considered.

Additionally, the attributes of `Unit`, `CompuMethod`, `DataConstr`, and `BaseType` according to [SWS_SwCluC_03038], [SWS_SwCluC_03039], [SWS_SwCluC_03042], [SWS_SwCluC_03043], and [SWS_SwCluC_03044] apply.

|(SRS_SwCluC_00010, SRS_SwCluC_00101, SRS_SwCluC_00102, SRS_SwCluC_00103, SRS_SwCluC_00106, SRS_SwCluC_00205)

[SWS_SwCluC_03038]{DRAFT} [The Cross Cluster Communication shall use the following attributes for the given `Unit` for the `SwCluCBManifResourceGuardValue` calculation:

- `Unit.factorSiToUnit` (if existing, else 1 applies)
- `Unit.offsetSiToUnit` (if existing, else 0 applies)
- `Unit.physicalDimension` (if existing, else [\[SWS_SwCluC_03041\]](#) applies)

Additionally, the attributes of `PhysicalDimension` according to [\[SWS_SwCluC_03040\]](#) and [\[SWS_SwCluC_03041\]](#) apply. *([SRS_SwCluC_00010](#), [SRS_SwCluC_00101](#), [SRS_SwCluC_00102](#), [SRS_SwCluC_00103](#), [SRS_SwCluC_00106](#), [SRS_SwCluC_00205](#))*

[SWS_SwCluC_03039]{DRAFT} [In case **no** `Unit` is given for the `SwCluCManifestResourceGuardValue` calculation, the `Cross Cluster Communication` shall use the following attribute values:

- `Unit.factorSiToUnit` = 1
- `Unit.offsetSiToUnit` = 0
- `Unit.physicalDimension` according to [\[SWS_SwCluC_03041\]](#)

Additionally, the attributes of `PhysicalDimension` according to [\[SWS_SwCluC_03041\]](#) apply. *([SRS_SwCluC_00010](#), [SRS_SwCluC_00101](#), [SRS_SwCluC_00102](#), [SRS_SwCluC_00103](#), [SRS_SwCluC_00106](#), [SRS_SwCluC_00205](#))*

[SWS_SwCluC_03040]{DRAFT} [The `Cross Cluster Communication` shall use the following attributes for the given `PhysicalDimension` for the `SwCluCManifestResourceGuardValue` calculation:

- `PhysicalDimension.shortName`
- `PhysicalDimension.currentExp` (if existing, else 0 applies)
- `PhysicalDimension.lengthExp` (if existing, else 0 applies)
- `PhysicalDimension.luminousIntensityExp` (if existing, else 0 applies)
- `PhysicalDimension.massExp` (if existing, else 0 applies)
- `PhysicalDimension.molarAmountExp` (if existing, else 0 applies)
- `PhysicalDimension.temperatureExp` (if existing, else 0 applies)
- `PhysicalDimension.timeExp` (if existing, else 0 applies)

([SRS_SwCluC_00010](#), [SRS_SwCluC_00101](#), [SRS_SwCluC_00102](#), [SRS_SwCluC_00103](#), [SRS_SwCluC_00106](#), [SRS_SwCluC_00205](#))

[SWS_SwCluC_03041]{DRAFT} [In case **no** `PhysicalDimension` is given, the `Cross Cluster Communication` shall use the following attribute values for the `SwCluCManifestResourceGuardValue` calculation:

- `PhysicalDimension.shortName` = `NoDimension`
- `PhysicalDimension.currentExp` = 0

- `PhysicalDimension.lengthExp = 0`
- `PhysicalDimension.luminousIntensityExp = 0`
- `PhysicalDimension.massExp = 0`
- `PhysicalDimension.molarAmountExp = 0`
- `PhysicalDimension.temperatureExp = 0`
- `PhysicalDimension.timeExp = 0`

](`SRS_SwCluC_00010`, `SRS_SwCluC_00101`, `SRS_SwCluC_00102`, `SRS_SwCluC_00103`, `SRS_SwCluC_00106`, `SRS_SwCluC_00205`)

The guard value calculation has to consider the intended compatibility of `CompuMethod` with different `category`, as defined in document [19] with [constr_1176] and [constr_1192]. Please note as well [constr_1375] w.r.t the existence of attributes of `CompuMethods`. Nevertheless, not all attributes are considered for the guard value, in order to increase compatibility between provider and requesters.

[SWS_SwCluC_03042]{DRAFT} [The `Cross Cluster Communication` shall use the following attributes for the given `CompuMethod` for the `SwCluCManifResourceGuardValue` calculation:

- `CompuMethod.unit`
- in case the `CompuMethod.category` is `IDENTICAL`
 - it is treated like a `CompuMethod` where the `category` is `LINEAR` where the `CompuMethod.compuPhysToInternal.compuScale` yield the conversion
$$int = \frac{N_0 + N_1 * phys}{D_0} \text{ if } N_0 \sim 0 \ \&\& \ N_1 \sim 1 \ \&\& \ D_0 \sim 0$$
- in case the `CompuMethod.category` is `LINEAR`
 - `CompuMethod.compuPhysToInternal.compuScale`
 - OR
 - `CompuMethod.compuInternalToPhys.compuScale`

where the `compuInternalToPhys` coefficients are converted to equivalent `compuPhysToInternal` coefficients.

 - * `CompuScale.compuNumerator.vs {ordered}`
 - * `CompuScale.compuDenominator.v`
- in case the `CompuMethod.category` is `SCALE_LINEAR`
 - `CompuMethod.compuPhysToInternal.compuScales`
 - `CompuMethod.compuPhysToInternal.compuDefaultValue` (if existing)

OR

- `CompuMethod.compuInternalToPhys.compuScaleS`
- `CompuMethod.compuInternalToPhys.compuDefaultValue` (if existing)
 - * `CompuScale.upperLimit`
 - * `CompuScale.lowerLimit`
 - * `CompuScale.compuNumerator.vs {ordered}`
 - * `CompuScale.compuDenominator.v`
- in case the `CompuMethod.category` is `RAT_FUNC` with 2 `compuNumerator` coefficients and 1 `compuDenominator` coefficient
 - this case is treated like a `CompuMethod` where the `category` is `LINEAR`
- in case the `CompuMethod.category` is `RAT_FUNC` not matching the `LINEAR` case

- `CompuMethod.compuPhysToInternal.compuScale`
- `CompuMethod.compuPhysToInternal.compuDefaultValue` (if existing)

AND

- `CompuMethod.compuInternalToPhys.compuScale`
 - `CompuMethod.compuInternalToPhys.compuDefaultValue` (if existing)
 - * `CompuScale.upperLimit`
 - * `CompuScale.lowerLimit`
 - * `CompuScale.compuInverseValue.vf` (if existing)
 - * `CompuScale.compuNumerator.vs {ordered}`
 - * `CompuScale.compuDenominator.v {ordered}`
 - in case the `CompuMethod.category` is `SCALE_RAT_FUNC`
 - `CompuMethod.compuPhysToInternal.compuScaleS`
 - `CompuMethod.compuPhysToInternal.compuDefaultValue` (if existing)
- AND
- `CompuMethod.compuInternalToPhys.compuScaleS`

- `CompuMethod.compuInternalToPhys.compuDefaultValue` (if existing)
 - * `CompuScale.upperLimit`
 - * `CompuScale.lowerLimit`
 - * `CompuScale.compuInverseValue.vf` (if existing)
 - * `CompuScale.compuNumerator.vs` {ordered}
 - * `CompuScale.compuDenominator.v` {ordered}
- in case the `CompuMethod.category` is `TEXTTABLE`
 - `CompuMethod.compuInternalToPhys.compuScales`
 - `CompuMethod.compuInternalToPhys.compuDefaultValue` (if existing)
 - * `CompuScale.upperLimit`
 - * `CompuScale.lowerLimit`
 - * `CompuScale.compuInverseValue.vf` (if existing)
 - * `CompuScale.compuConst.vt`
- in case the `CompuMethod.category` is `BITFIELD_TEXTTABLE`
 - `CompuMethod.compuInternalToPhys.compuScales`
 - `CompuMethod.compuInternalToPhys.compuDefaultValue` (if existing)
 - * `CompuScale.upperLimit`
 - * `CompuScale.lowerLimit`
 - * `CompuScale.mask`
 - * `CompuScale.compuInverseValue.vf` (if existing)
 - * `CompuScale.compuConst.vt`
- in case the `CompuMethod.category` is `SCALE_LINEAR_AND_TEXTTABLE`
 - `CompuMethod.compuInternalToPhys.compuScales`
 - `CompuMethod.compuInternalToPhys.compuDefaultValue` (if existing)
 - * `CompuScale.upperLimit`
 - * `CompuScale.lowerLimit`
 - * `CompuScale.mask`

- * `CompuScale.compuInverseValue.vf` (if existing)
- * `CompuScale.compuConst.vt` (if existing)
- * `CompuScale.compuNumerator.vs {ordered}` (if existing)
- * `CompuScale.compuDenominator.v` (if existing)
- in case the `CompuMethod.category` is `SCALE_RATIONAL_AND_TEXTTABLE`
 - `CompuMethod.compuPhysToInternal.compuScales`
 - `CompuMethod.compuPhysToInternal.compuDefaultValue` (if existing)
 - AND
 - `CompuMethod.compuInternalToPhys.compuScales`
 - `CompuMethod.compuInternalToPhys.compuDefaultValue` (if existing)
 - * `CompuScale.upperLimit`
 - * `CompuScale.lowerLimit`
 - * `CompuScale.mask`
 - * `CompuScale.compuInverseValue.vf` (if existing)
 - * `CompuScale.compuConst.vt` (if existing)
 - * `CompuScale.compuNumerator.vs {ordered}` (if existing)
 - * `CompuScale.compuDenominator.v {ordered}` (if existing)
- in case the `CompuMethod.category` is `TAB_NOINTP`
 - `CompuMethod.compuInternalToPhys.compuScales`
 - `CompuMethod.compuInternalToPhys.compuDefaultValue` (if existing)
 - * `CompuScale.upperLimit`
 - * `CompuScale.lowerLimit`
 - * `CompuScale.compuInverseValue.vf` (if existing)
 - * `CompuScale.compuConst.vt` (if existing)

Additionally, the attributes of `Unit` according to [SWS_SwCluC_03038], [SWS_SwCluC_03039] apply.

]([SRS_SwCluC_00010](#), [SRS_SwCluC_00101](#), [SRS_SwCluC_00102](#), [SRS_SwCluC_00103](#), [SRS_SwCluC_00106](#), [SRS_SwCluC_00205](#))

[SWS_SwCluC_03043]{DRAFT} [The Cross Cluster Communication shall use the following attributes for the given `DataConstr` for the `SwCluCManifestResourceGuardValue` calculation:

- `DataConstr.dataConstrRule.physConstrs.upperLimit` (if existing)
- `DataConstr.dataConstrRule.physConstrs.lowerLimit` (if existing)
- `DataConstr.dataConstrRule.physConstrs.monotony` (if existing)
- `DataConstr.dataConstrRule.physConstrs.maxGradient` (if existing)
- `DataConstr.dataConstrRule.physConstrs.maxDiff` (if existing)
- `DataConstr.dataConstrRule.internalConstrs.upperLimit` (if existing, else based on `baseTypeEncoding` and `baseTypeSize` the technical upper limit is taken)
- `DataConstr.dataConstrRule.internalConstrs.lowerLimit` (if existing, else based on `baseTypeEncoding` and `baseTypeSize` the technical lower limit is taken)
- `DataConstr.dataConstrRule.internalConstrs.monotony` (if existing, else `noMonotony`)
- `DataConstr.dataConstrRule.internalConstrs.maxGradient` (if existing)
- `DataConstr.dataConstrRule.internalConstrs.maxDiff` (if existing)

](*SRS_SwCluC_00010, SRS_SwCluC_00101, SRS_SwCluC_00102, SRS_SwCluC_00103, SRS_SwCluC_00106, SRS_SwCluC_00205*)

[SWS_SwCluC_03044]{DRAFT} [The Cross Cluster Communication shall use the following attributes for the given `SwBaseType` for the `SwCluCManifestResourceGuardValue` calculation:

- `SwBaseType.baseTypeEncoding`
- `SwBaseType.baseTypeSize`
- `SwBaseType.byteOrder`
- `SwBaseType.nativeDeclaration`
- `SwBaseType.memAlignment` (if existing, else 0 applies)

](*SRS_SwCluC_00010, SRS_SwCluC_00101, SRS_SwCluC_00102, SRS_SwCluC_00103, SRS_SwCluC_00106, SRS_SwCluC_00205*)

7.3.2.3 Cross Cluster Communication Base Socket

In general, it is possible that the communication between [Application Software Clusters](#) needs some basic infrastructure from the [Host Software Cluster](#). For instance, to pass an activity or event between [Application Software Clusters](#). Usually, such event passing requires some knowledge about the overall environment, which is **NOT** available in an [Application Software Cluster](#). For instance, in the [Application Software Cluster](#), only a subset of the defined partitions (and related [EcucPartitions](#) plus [OsApplications](#)) are known.

[SWS_SwCluC_03012]{DRAFT} [If the implementation of a [Cross Cluster Communication](#) requires some basic infrastructure from the [Host Software Cluster](#), it shall use the means of the [SwCluCXccBaseSocket](#) configuration to link to the resource pool.]()

[SWS_SwCluC_03013]{DRAFT} [The [Cross Cluster Communication](#) of the [Software Cluster Connection](#) shall put one [Resource Entry](#) for each associated [SwCluCXccBaseSocket](#) into the [Binary Manifest](#).]()

7.3.2.4 Cross Cluster Communication and McSupport Data

[SWS_SwCluC_03071]{DRAFT} [The [Cross Cluster Communication](#) of the [Software Cluster Connection](#) shall provide an *MC-Support* (Measurement and Calibration) description as part of its *Basic Software Module Description*.]([SRS_SwCluC_00300](#))

[SWS_SwCluC_03072]{DRAFT} [The [McSupportData](#) element begin part of [[SWS_SwCluC_03071](#)] and its sub-structure shall be self-contained, in the sense that there is no need to deliver the whole upstream descriptions of the ECU (including the [ECU Extract](#), [Software Component](#) descriptions, [Basic Software Module](#) descriptions, [ECU Configuration Values](#) descriptions, etc.), in order to later generate the final "A2L"-file. This means that the [Cross Cluster Communication](#) generator has to copy the required information from the upstream descriptions into the [McSupportData](#) element.]([SRS_SwCluC_00300](#))

[SWS_SwCluC_03073]{DRAFT} [The [Cross Cluster Communication](#) generator shall export the effective [SwDataDefProps](#) (including all of the referenced and aggregated sub-elements like e.g. [CompuMethod](#) or [SwRecordLayout](#)) in the role [resultingProperties](#), for each [McDataInstance](#), after resolving the precedence rules defined in the SW-Component Template [[19](#)] chapter *Properties of Data Definitions*. Thereby, the [ImplementationDataType](#) properties [compuMethod](#) and [dataConstr](#) are not taken in consideration for effective [SwDataDefProps](#) of the [McDataInstance](#), due to their refinement nature of **C** and **AI**.]([SRS_SwCluC_00300](#))

[SWS_SwCluC_03074]{DRAFT} [The [Cross Cluster Communication](#) generator shall export one entry in the [McSupportData](#), describing the default data instance

according to [SWS_SwCluC_03120], with the role `mcParameterInstance`, with the following attributes:

- `swCalibrationAccess` set to `readWrite`
- effective `SwDataDefProps` according to [SWS_SwCluC_03073]
- `McDataInstance.subElements` for array elements or structure elements, if applicable
- `symbol` set to the C-symbol name used for the default data instance

if

- the parameter `SwCluCXccSwCluCXccDefaultDataHandling` is set to `DEFAULTS_AS_CONSTANTS`,

AND

- the effective `swCalibrationAccess` according to [SWS_SwCluC_03073] of the related `VariableDataPrototype` is set to `readOnly` or `readWrite`

](SRS_SwCluC_00300)

[SWS_SwCluC_03077]{DRAFT} [The `Cross Cluster Communication` generator shall export one entry in the `McSupportData`, describing the default data instance according to [SWS_SwCluC_03120], with the role `mcParameterInstance`, with the following attributes:

- `swCalibrationAccess` set to `readOnly`
- effective `SwDataDefProps` according to [SWS_SwCluC_03073]
- `McDataInstance.subElements` for array elements or structure elements, if applicable
- `symbol` set to the C-symbol name used for the default data instance

if

- the parameter `SwCluCXccSwCluCXccDefaultDataHandling` is set to `DEFAULTS_AS_CONSTANTS`

AND

- the effective `SwDataDefProps` according to [SWS_SwCluC_03073] of the related `VariableDataPrototype` is set to `readOnly` or `readWrite`

](SRS_SwCluC_00300)

[SWS_SwCluC_03075]{DRAFT} [The `Cross Cluster Communication` generator shall export one entry in the `McSupportData`, describing the default parameter instance according to [SWS_SwCluC_03006], with the role `mcParameterInstance`, with the following attributes:

- `swCalibrationAccess` set to `readWrite`

- effective `SwDataDefProps` according to [SWS_SwCluC_03073]
- `McDataInstance.subElements` for array elements or structure elements, if applicable
- `symbol` set to the C-symbol name used for the default parameter instance

](SRS_SwCluC_00300)

[SWS_SwCluC_03076]{DRAFT} [If the `swCalibrationAccess` of a `VariableDataPrototype` instance in the delegation `PPortPrototype` at the `CompositionSwComponentType` at the `CompositionSwComponentType` of the `rootSoftwareComposition` of the `Ecu Extract` is set to `readOnly` or `readWrite`, the `Cross Cluster Communication` generator shall export one entry in the `McSupportData`, describing the data instance according to [SWS_SwCluC_03101], with the role `mcVariableInstance`, with the following attributes:

- effective `SwDataDefProps` (inclusive `swCalibrationAccess`) according to [SWS_SwCluC_03073]
- `McDataInstance.subElements` for array elements or structure elements, if applicable
- `symbol` set to the C-symbol name used for the data instance
- if applicable, `flatMapEntry` referencing to the corresponding `FlatInstanceDescriptor` element of the `VariableDataPrototype`

](SRS_SwCluC_00300)

7.3.3 Sender Receiver Communication

7.3.3.1 Restrictions on VFB communication features

[SWS_SwCluC_03064]{DRAFT} [The `Cross Cluster Communication` of the `Software Cluster Connection` shall reject the configuration, if there is a “N:1” sender-receiver communication with last-is-the-best semantic.](SRS_SwCluC_00100, SRS_SwCluC_00101)

[SWS_SwCluC_03065]{DRAFT} [The `Cross Cluster Communication` of the `Software Cluster Connection` shall reject the configuration, if there is a “1:N” sender-receiver communication with event semantic (queued communication).](SRS_SwCluC_00100, SRS_SwCluC_00101)

[SWS_SwCluC_03068]{DRAFT} [The implementation of a `Cross Cluster Communication` shall support that `Data Communication Graphs` between `Application Software Clusters` can be added, without modification of the `Host Software Cluster`.](SRS_SwCluC_00100, SRS_SwCluC_00101)

7.3.3.2 Data Consistency

[SWS_SwCluC_03084] [If the attribute `DataComProps.dataConsistencyPolicy` is set to `consistencyMechanismRequired` for the `Data Communication Graph`, the `Cross Cluster Communication` of the `Software Cluster Connection` shall use an appropriate mechanism to guarantee data consistency if data inconsistency could occur.]([SRS_SwCluC_00100](#), [SRS_SwCluC_00101](#), [SRS_SwCluC_00107](#))

Please note that such a consistency mechanism is implemented preferable with a lock free pattern, since in a clustered ECU software the optimization of semaphores is barely possible.

[SWS_SwCluC_03085] [If the attribute `DataComProps.dataConsistencyPolicy` is set to `noConsistencyMechanism` for the `Data Communication Graph`, the `Cross Cluster Communication` of the `Software Cluster Connection` shall not use any mechanisms to guarantee data consistency.]([SRS_SwCluC_00100](#), [SRS_SwCluC_00101](#), [SRS_SwCluC_00107](#))

Rationale: If it is guaranteed on system level, that the data exchange on that `Data Communication Graph` will not cause any data inconsistencies, `noConsistencyMechanism` can be set. Thus, no extra data consistency mechanism is required to be used by the `Software Cluster Connection`.

7.3.3.3 Transmission

[SWS_SwCluC_03101]{DRAFT} [The `Cross Cluster Communication` of the `Software Cluster Connection` shall provide one data instance, for each assigned `Data Communication Graph`

- where the referenced `VariableDataPrototype` is owned by a delegation `PPortPrototype` at the `CompositionSwComponentType` of the `rootSoftwareComposition` of the `Ecu Extract` AND
- where implicit communication applies to that `VariableDataPrototype` OR
- where explicit unqueued communication applies to that `VariableDataPrototype`

]([SRS_SwCluC_00100](#), [SRS_SwCluC_00101](#))

[SWS_SwCluC_03102]{DRAFT} [The data instance created according to [\[SWS_SwCluC_03101\]](#) shall be mapped to a VAR memory section, according to document [\[17\]](#).]([SRS_SwCluC_00100](#), [SRS_SwCluC_00101](#))

[SWS_SwCluC_03103]{DRAFT} [The `Cross Cluster Communication` of the `Software Cluster Connection` shall make the `data` instance created according to **[SWS_SwCluC_03101]**, accessible to other `Software Clusters` via a `Resource Entry` in the `Binary Manifest`.](*SRS_SwCluC_00100*, *SRS_SwCluC_00101*)

[SWS_SwCluC_03106]{DRAFT} [When implicit or explicit unqueued communication applies, the `Rte_Rips_Write` shall update the `data` instance created according to **[SWS_SwCluC_03101]**), and return `RTE_E_OK`.](*SRS_SwCluC_00100*, *SRS_SwCluC_00101*)

[SWS_SwCluC_03142]{DRAFT} [The `Cross Cluster Communication` of the `Software Cluster Connection` shall provide one `Resource Entry`, for each assigned `Data Communication Graph`

- where the referenced `VariableDataPrototype` is owned by a delegation `PPortPrototype` at the `CompositionSwComponentType` of the `rootSoftwareComposition` of the `Ecu Extract` AND
- where explicit queued communication applies to that `VariableDataPrototype`

This `Resource Entry` shall be used to link the access of the related `Rte_Rips_Write` service to the according queue instance on the receiving `Software Cluster`.](*SRS_SwCluC_00100*, *SRS_SwCluC_00101*)

[SWS_SwCluC_03107]{DRAFT} [When explicit queued communication applies, and the `Resource Entry` created according to **[SWS_SwCluC_03142]** is not connected, the `Rte_Rips_Write` shall discard the write access, and return `RTE_E_OK`.](*SRS_SwCluC_00100*, *SRS_SwCluC_00101*)

[SWS_SwCluC_03108]{DRAFT} [When explicit queued communication applies, and the `Resource Entry` created according to **[SWS_SwCluC_03142]** is connected, the `Rte_Rips_Write` shall check the queue status (See **[SWS_SwCluC_03135]**), to determine whether or not the data can be enqueued.](*SRS_SwCluC_00100*, *SRS_SwCluC_00101*)

[SWS_SwCluC_03109]{DRAFT} [When explicit queued communication applies, and the `Resource Entry` created according to **[SWS_SwCluC_03142]** is connected, and the queue is not full, the `Rte_Rips_Write` shall enqueue the data and return `RTE_E_OK` (See **[SWS_SwCluC_03135]**).](*SRS_SwCluC_00100*, *SRS_SwCluC_00101*)

[SWS_SwCluC_03110]{DRAFT} [When explicit queued communication applies, and the `Resource Entry` created according to **[SWS_SwCluC_03142]** is connected, but the queue is full, the `Rte_Rips_Write` shall discard the write access and return `RTE_E_LIMIT` (See **[SWS_SwCluC_03135]**).](*SRS_SwCluC_00100*, *SRS_SwCluC_00101*)

[SWS_SwCluC_03080] [When implicit or explicit unqueued communication applies and the attribute `sendIndication` is set to `anySendOperation` for the `Data`

Communication Graph, the call of the `Rte_Rips_Write` shall indicate the occurrence of a send operation for the related data instance.]([SRS_SwCluC_00100](#), [SRS_SwCluC_00101](#))

This send operation indication can be used at the receiving Software Clusters to determine update flags or data receive event triggers.

Please note that the specification behavior supports a polling of those send indications and therefore an active passing of those events can be avoided.

The value of the `sendIndication` attribute is only relevant for unqueued communication (last-is-the best), since the implementation of a queue on the receiver side provides in any case the possibility to detect enqueue operations.

[SWS_SwCluC_03111]{DRAFT} [The data instance created according to [\[SWS_SwCluC_03101\]](#) shall be initialized according to the `NonqueuedSenderComSpec.initValue` in the `PPortPrototype` at the `CompositionSwComponentType` of the `rootSoftwareComposition` of the `Ecu Extract`.]([SRS_SwCluC_00100](#), [SRS_SwCluC_00101](#))

[SWS_SwCluC_03112]{DRAFT} [If acknowledgment is enabled, and the resource created according to [\[SWS_SwCluC_03103\]](#) is not connected, the `Rte_Rips_Feedback` API shall return `RTE_E_UNCONNECTED`.]([SRS_SwCluC_00100](#), [SRS_SwCluC_00101](#))

[SWS_SwCluC_03113]{DRAFT} [If acknowledgement is enabled, and the resource created according to [\[SWS_SwCluC_03103\]](#) is connected, the `Rte_Rips_Feedback` API shall return `RTE_E_TRANSMIT_ACK`.]([SRS_SwCluC_00100](#), [SRS_SwCluC_00101](#))

7.3.3.4 Reception

[SWS_SwCluC_03120]{DRAFT} [The `Cross Cluster Communication` of the `Software Cluster Connection` shall provide one default data instance, for each assigned `Data Communication Graph`

- where the referenced `VariableDataPrototype` is owned by a delegation `RPortPrototype` at the `CompositionSwComponentType` of the `rootSoftwareComposition` of the `Ecu Extract` AND
- where implicit communication applies to that `VariableDataPrototype` OR
- where explicit unqueued communication applies to that `VariableDataPrototype`

]([SRS_SwCluC_00100](#), [SRS_SwCluC_00101](#))

[SWS_SwCluC_03133]{DRAFT} [The `Cross Cluster Communication` of the `Software Cluster Connection` shall provide a queue data instance (where the

queue size corresponds to the specified queue length), for each assigned [Data Communication Graph](#)

- where the referenced [VariableDataPrototype](#) is owned by a delegation [RPortPrototype](#) at the [CompositionSwComponentType](#) of the [rootSoftwareComposition](#) of the [Ecu Extract](#) AND
- where explicit queued communication applies to that [VariableDataPrototype](#)

]([SRS_SwCluC_00100](#), [SRS_SwCluC_00101](#))

[SWS_SwCluC_03134]{DRAFT} [The [Cross Cluster Communication](#) of the [Software Cluster Connection](#) shall determine the queue size according to the [queueLength](#) attribute of the [QueuedReceiverComSpec](#)]([SRS_SwCluC_00100](#), [SRS_SwCluC_00103](#))

[SWS_SwCluC_03135]{DRAFT} [When [\[SWS_SwCluC_03133\]](#) applies, the [Cross Cluster Communication](#) of the [Software Cluster Connection](#) shall provide a data instance, representing the number of possible entries in the queue.]([SRS_SwCluC_00100](#), [SRS_SwCluC_00101](#))

[SWS_SwCluC_03122]{DRAFT} [If the parameter [SwCluCXccSwCluCXccDefaultDataHandling](#) is set to [DEFAULTS_AS_CONSTANTS](#), the default data instance created according to [\[SWS_SwCluC_03120\]](#) shall be mapped to a [CONST](#) memory section, according to document [\[17\]](#).]([SRS_SwCluC_00100](#), [SRS_SwCluC_00101](#))

[SWS_SwCluC_03121]{DRAFT} [If the parameter [SwCluCXccSwCluCXccDefaultDataHandling](#) is set to [DEFAULTS_AS_CALPRMS](#), the default data instance created according to [\[SWS_SwCluC_03120\]](#) shall be mapped to a [CALPRM](#) memory section, according to document [\[17\]](#).]([SRS_SwCluC_00100](#), [SRS_SwCluC_00101](#))

Please note as well that section [7.3.2.4](#) is relevant for calibration parameters instantiated by [Software Cluster Connection](#).

[SWS_SwCluC_03123]{DRAFT} [The data instances created according to [\[SWS_SwCluC_03120\]](#), [\[SWS_SwCluC_03133\]](#) and [\[SWS_SwCluC_03135\]](#) shall be mapped to a [VAR](#) memory section, according to document [\[17\]](#).]([SRS_SwCluC_00100](#), [SRS_SwCluC_00101](#))

[SWS_SwCluC_03124]{DRAFT} [The default data instance created according to [\[SWS_SwCluC_03120\]](#) shall be initialized according to the [NonqueuedReceiverComSpec.initValue](#) in the [RPortPrototype](#) at the [CompositionSwComponentType](#) of the [rootSoftwareComposition](#) of the [Ecu Extract](#).]([SRS_SwCluC_00100](#), [SRS_SwCluC_00101](#))

[SWS_SwCluC_03126]{DRAFT} [The [Cross Cluster Communication](#) of the [Software Cluster Connection](#) shall use the default data instance created according to [\[SWS_SwCluC_03120\]](#) as default handle in the corresponding [Resource Entry](#) in the [Binary Manifest](#).]([SRS_SwCluC_00100](#), [SRS_SwCluC_00101](#))

[SWS_SwCluC_03136]{DRAFT} [The [Cross Cluster Communication](#) of the [Software Cluster Connection](#) shall make the data instance created according to [\[SWS_SwCluC_03133\]](#) accessible from other [Software Clusters](#), via a [Resource Entry](#) in the [Binary Manifest](#).] ([SRS_SwCluC_00100](#), [SRS_SwCluC_00101](#))

[SWS_SwCluC_03130]{DRAFT} [When explicit unqueued communication via [dataReceivePointByArguments](#) applies, and the [Resource Entry](#) created according to [\[SWS_SwCluC_03126\]](#) is not connected, the [Rte_Rips_Read](#) shall copy the value of default data instance created according to [\[SWS_SwCluC_03120\]](#) to the location of the OUT parameter <data>, and shall return `RTE_E_UNCONNECTED`.] ([SRS_SwCluC_00100](#), [SRS_SwCluC_00101](#))

[SWS_SwCluC_03131]{DRAFT} [When explicit unqueued communication via [dataReceivePointByValues](#) applies, and the [Resource Entry](#) created according to [\[SWS_SwCluC_03126\]](#) is not connected, the [Rte_Rips_DRead](#) shall return the value of default data instance created according to [\[SWS_SwCluC_03120\]](#).] ([SRS_SwCluC_00100](#), [SRS_SwCluC_00101](#))

[SWS_SwCluC_03132]{DRAFT} [When explicit unqueued communication via [dataReceivePointByArguments](#) applies, and the [Resource Entry](#) created according to [\[SWS_SwCluC_03126\]](#) is connected, the [Rte_Rips_Read](#) shall copy the value of the corresponding data instance of the provider to the location of the OUT parameter <data>, and shall return `RTE_E_OK`.] ([SRS_SwCluC_00100](#), [SRS_SwCluC_00101](#))

[SWS_SwCluC_03137]{DRAFT} [When explicit queued communication applies, and the resource created according to [\[SWS_SwCluC_03136\]](#) is not connected, the [Rte_Rips_Read](#) shall discard the read access, and return `RTE_E_UNCONNECTED`.] ([SRS_SwCluC_00100](#), [SRS_SwCluC_00101](#))

[SWS_SwCluC_03138]{DRAFT} [When explicit queued communication applies, and the [Resource Entry](#) created according to [\[SWS_SwCluC_03136\]](#) is connected, but no entry is available in the queue, the [Rte_Rips_Read](#) shall discard the read access, and return `RTE_E_NO_DATA`.] ([SRS_SwCluC_00100](#), [SRS_SwCluC_00101](#))

[SWS_SwCluC_03139]{DRAFT} [When explicit queued communication applies, and the [Resource Entry](#) created according to [\[SWS_SwCluC_03136\]](#) is connected, the [Rte_Rips_Read](#) shall copy the value of the first available entry of the corresponding data instance to the location of the OUT parameter <data>, and return `RTE_E_OK`.] ([SRS_SwCluC_00100](#), [SRS_SwCluC_00101](#))

[SWS_SwCluC_03140]{DRAFT} [When [\[SWS_SwCluC_03139\]](#) applies, the [Rte_Rips_Read](#) shall dequeue the data from the corresponding queue.] ([SRS_SwCluC_00100](#), [SRS_SwCluC_00101](#))

[SWS_SwCluC_03143]{DRAFT} [If explicit unqueued communication applies, and the [Resource Entry](#) in the [Binary Manifest](#) created according to [\[SWS_SwCluC_03126\]](#) is not connected, the [Rte_Rips_DataIsUpdated](#) shall return `FALSE`.] ([SRS_SwCluC_00100](#), [SRS_SwCluC_00101](#))

[SWS_SwCluC_03144]{DRAFT} [If explicit unqueued communication applies, and the `Resource Entry` in the `Binary Manifest` created according to [SWS_SwCluC_03126] is connected, and the sender has updated the data since the previous execution of the corresponding `Rte_Rips_Read` service, the `Rte_Rips_DataIsUpdated` shall return TRUE

](SRS_SwCluC_00100, SRS_SwCluC_00101)

[SWS_SwCluC_03081] [The `Rte_Rips_DataIsUpdated` shall return TRUE if

- explicit unqueued communication applies

AND

- the `Resource Entry` in the `Binary Manifest` created according to [SWS_SwCluC_03126] is connected

AND

- the occurrence of a send operation was indicated after previous calls of `Rte_Read` or `Rte_DRead` related to this reading software component.

](SRS_SwCluC_00100, SRS_SwCluC_00101)

[SWS_SwCluC_03082] [The `Rte_Rips_DataIsUpdated_EventActivation` shall return TRUE if

- the `Resource Entry` in the `Binary Manifest` created according to [SWS_SwCluC_03126] or [SWS_SwCluC_03136] is connected

AND

- the occurrence of a send operation was indicated after previous calls of this instance of the `Rte_Rips_DataIsUpdated_EventActivation`

OR

- a enqueue operation occurred after previous calls of this instance of the `Rte_Rips_DataIsUpdated_EventActivation`

](SRS_SwCluC_00100, SRS_SwCluC_00101)

7.3.4 NvData communication

7.3.4.1 Restrictions on VFB communication features

Please note that the `Cross Cluster Communication` of the `Software Cluster Connection` does not support the NvData communication. This means its not possible that a communication graph involves a `NvBlockSwComponent` and additionally get mapped to the `Cross Software Cluster Communication Plug-In`.

This use case can be implemented by a software component copying the data of a `NvBlockSwComponent` to the `Software Cluster`'s interface using a regular sender receiver communication.

[SWS_SwCluC_CONSTR_03400] Data Communication Graph which involves a `NvBlockSwComponent` [The `Cross Cluster Communication` of the `Software Cluster Connection` shall not be configured such that, a `Data Communication Graph` which involves a `NvBlockSwComponent` is associated to the `Cross Cluster Communication` according to [SWS_SwCluC_03002].] (SRS_SwCluC_00100)

7.3.5 Client Server Communication

7.3.5.1 General

[SWS_SwCluC_03145]{DRAFT} [The `Cross Cluster Communication` of the `Software Cluster Connection` shall ensure that the result of a `ClientServerOperation` is dispatched to the correct client, if more than one client invokes the `ClientServerOperation`] (SRS_SwCluC_00100, SRS_SwCluC_00103)

[SWS_SwCluC_03146]{DRAFT} [The `Cross Cluster Communication` shall support multiple `Clients` invoking the same `ClientServerOperation` on a server ('N:1' Communication where $N \geq 1$).] (SRS_SwCluC_00100, SRS_SwCluC_00103)

7.3.5.2 Timeout

[SWS_SwCluC_03147]{DRAFT} [The `Cross Cluster Communication` of the `Software Cluster Connection` shall ensure that timeout monitoring is performed for client-server communication.] (SRS_SwCluC_00100, SRS_SwCluC_00103)

[SWS_SwCluC_03087] [The `Cross Cluster Communication` of the `Software Cluster Connection` shall implement the timeout monitoring of a `client` in the associated `SwCluC_Xcc_MainFunction`.] (SRS_SwCluC_00100, SRS_SwCluC_00103)

[SWS_SwCluC_03088] [When a timeout occurred, the `Cross Cluster Communication` of the `Software Cluster Connection` shall discard any subsequent responses to that request.] (SRS_SwCluC_00100, SRS_SwCluC_00103)

Please note, in case a timeout occurs the related `Rte_Rips_ReturnResult` returns `RTE_E_TIMEOUT` ([SWS_SwCluC_03169]) and buffers for the `IN/OUT` and `OUT` parameters are not be modified ([SWS_Rte_89023], [SWS_Rte_01114]).

[SWS_SwCluC_03089] [The `Cross Cluster Communication` of the `Software Cluster Connection` shall reject configurations where a `client` with a `ServerCallPoint.timeout` value > 0 is associated to a `SwCluC_Xcc_MainFunction` where the `ServerCallPoint.timeout` value is not an integer multiple of

the `SwCluCXccMainFunction.SwCluCXccMainTimeBase` value.]([SRS_SwCluC_00100](#), [SRS_SwCluC_00103](#))

[SWS_SwCluC_03090] [The `Cross Cluster Communication` of the `Software Cluster Connection` shall associate all clients to a specific `SwCluC_Xcc_MainFunction` which are explicitly mapped via a `SwCluCXccClientInstanceRef` of the related `SwCluCXccMainFunction` container.]([SRS_SwCluC_00100](#), [SRS_SwCluC_00103](#))

[SWS_SwCluC_03091] [The `Cross Cluster Communication` of the `Software Cluster Connection` shall associate all clients which are not referenced explicitly by a `SwCluCXccClientInstanceRef` with the default `SwCluC_Xcc_MainFunction` for the `EcucPartition` on which the `SwComponentPrototype` owning the client is mapped to.]([SRS_SwCluC_00100](#), [SRS_SwCluC_00103](#))

[SWS_SwCluC_03092] [The `Cross Cluster Communication` of the `Software Cluster Connection` shall reject configurations where a client in an assigned `Client Server Communication Graph` with a `ServerCallPoint.timeout` value > 0 exists, which is not associated a `SwCluC_Xcc_MainFunction`.]([SRS_SwCluC_00100](#), [SRS_SwCluC_00103](#))

[SWS_SwCluC_CONSTR_03093] [Clients of a `SwComponentPrototype` shall only be associated to `SwCluC_Xcc_MainFunctions` belonging to the identical `EcucPartition` on which the `SwComponentPrototype` is mapped to.]([SRS_SwCluC_00100](#), [SRS_SwCluC_00103](#))

7.3.5.3 Scheduling of main functions

[SWS_SwCluC_03094] [In case `SwCluCXccScheduleIntegration` is set to `SERVICE_SOFTWARE_COMPONENT`, the `Cross Cluster Communication` of the `Software Cluster Connection` shall create one partition specific `Service Software Component` per configured `EcucPartition` for the `Xcc`, with the name `SwCluC_Xcc_<EcucPartition shortName>`.]([SRS_SwCluC_00100](#), [SRS_SwCluC_00103](#))

[SWS_SwCluC_03095] [In case `SwCluCXccScheduleIntegration` is set to `SERVICE_SOFTWARE_COMPONENT`, the `Cross Cluster Communication` of the `Software Cluster Connection` shall create one `RunnableEntity` per configured `SwCluCXccMainFunction` container in the partition specific `Service Software Component` according [\[SWS_SwCluC_03094\]](#).

The `EcucPartition` is determined by the parameter `SwCluCXccMainPartitionRef`. The attributes of the `RunnableEntity` shall be set as following:

- `symbol` is set to the name of the `SwCluC_Xcc_MainFunction` according [\[SWS_SwCluC_91002\]](#)
- `canBeInvokedConcurrently` is set to `false`

](SRS_SwCluC_00100, SRS_SwCluC_00103)

[SWS_SwCluC_03096] [In case `SwCluCXccScheduleIntegration` is set to `SERVICE_SOFTWARE_COMPONENT`, the Cross Cluster Communication of the Software Cluster Connection shall create one `TimingEvent` per configured `SwCluCXccMainFunction` container in the partition specific Service Software Component according **[SWS_SwCluC_03094]**.

The attributes of the `TimingEvent` shall be set as following:

- `startOnEvent` is set to the `RunnableEntity` according **[SWS_SwCluC_03095]**
- `period` value is set according the `SwCluCXccMainTimeBase` parameter

](SRS_SwCluC_00100, SRS_SwCluC_00103)

Note: `shortName` of `TimingEvent` is vendor specific.

Note: According **[SWS_BSW_00001]** the `SwCluC` module has to provide a BSW Module description containing a `BswModuleDescription`. This general requirement is not repeated in this specification, but it's the basis for further requirements on descriptive elements.

[SWS_SwCluC_03097] [In case `SwCluCXccScheduleIntegration` is set to `BASIC_SW_MODULE`, the Cross Cluster Communication of the Software Cluster Connection shall create one `BswSchedulableEntity` per configured `SwCluCXccMainFunction` container in its `BswModuleDescription`.

The attributes of the `BswSchedulableEntity` shall be set as following:

- `shortName` is set to the name of the `SwCluC_Xcc_MainFunction` according **[SWS_SwCluC_91002]**
- `reentrancyLevel` is set to `false`

](SRS_SwCluC_00100, SRS_SwCluC_00103)

[SWS_SwCluC_03098] [In case `SwCluCXccScheduleIntegration` is set to `BASIC_SW_MODULE`, the Cross Cluster Communication of the Software Cluster Connection shall create one `BswTimingEvent` per configured `SwCluCXccMainFunction` container in its `BswModuleDescription`.

The attributes of the `BswTimingEvent` shall be set as following:

- `startsOnEvent` is set to the `BswSchedulableEntity` according **[SWS_SwCluC_03097]**
- `period` value is set according the `SwCluCXccMainTimeBase` parameter

](SRS_SwCluC_00100, SRS_SwCluC_00103)

Note: `shortName` of `BswTimingEvent` is vendor specific.

7.3.5.4 Buffering

[SWS_SwCluC_03150]{DRAFT} [The [Cross Cluster Communication](#) on the client side of the [Software Cluster Connection](#) shall provide a request buffer for each client of the assigned [Client Server Communication Graph](#).

Note: The structure of the request buffer is implementation specific, but the [Cross Cluster Communication](#) has to store at least the IN parameters and IN/OUT parameters, the transaction handle and the status code of the communication. |(SRS_SwCluC_00100, SRS_SwCluC_00103)

[SWS_SwCluC_03152]{DRAFT} [The [Cross Cluster Communication](#) on the server side of the [Software Cluster Connection](#) shall provide a request queue with the specified queue length (See [\[SWS_SwCluC_03154\]](#)), for each assigned [Client Server Communication Graph](#), where the referenced [ClientServerOperation](#) is owned by a delegation [PPortPrototype](#) at the [CompositionSwComponentType](#) of the [rootSoftwareComposition](#) of the [Ecu Extract](#).

Note: The structure of the queue is implementation specific, but the [Cross Cluster Communication](#) has to store at least the IN/OUT and OUT parameters, the transaction handle and the status code of the communication. |(SRS_SwCluC_00100, SRS_SwCluC_00103)

[SWS_SwCluC_03153]{DRAFT} [The [Cross Cluster Communication](#) on the server side of the [Software Cluster Connection](#) shall provide N response buffers (where N corresponds to the specified queue length according [\[SWS_SwCluC_03154\]](#)), for each assigned [Client Server Communication Graph](#), where the referenced [ClientServerOperation](#) is owned by a delegation [PPortPrototype](#) at the [CompositionSwComponentType](#) of the [rootSoftwareComposition](#) of the [Ecu Extract](#).

Note: The structure of the response buffer is implementation specific, but the [Cross Cluster Communication](#) has to store at least the IN/OUT and OUT parameters, the transaction handle and the status code of the communication. |(SRS_SwCluC_00100, SRS_SwCluC_00103)

[SWS_SwCluC_03154]{DRAFT} [The [Cross Cluster Communication](#) on the server side of the [Software Cluster Connection](#) shall determine the queue length according to the following priority rules (highest priority first):

1. value of the ECU-C parameter [RteServerQueueLength](#)
2. value of the [queueLength](#) attribute of the [ServerComSpec](#)

|(SRS_SwCluC_00100, SRS_SwCluC_00103)

Note: The queue length can be pre-defined at Software Cluster design time with the attribute [ClientServerOperationComProps.queueLength](#). But it is in the responsibility of the integrator to consider this value for the cluster configuration.

[SWS_SwCluC_03155]{DRAFT} [The [Cross Cluster Communication](#) on the server side of the [Software Cluster Connection](#) shall handle the requests in a first-in-first-out queue.]([SRS_SwCluC_00100](#), [SRS_SwCluC_00103](#))

[SWS_SwCluC_03156]{DRAFT} [The [Cross Cluster Communication](#) of the [Software Cluster Connection](#) shall make the request buffer instance created according to [SWS_SwCluC_03150] accessible for the [Software Cluster](#) implementing the server, via a [Resource Entry](#) in the [Binary Manifest](#).]([SRS_SwCluC_00100](#), [SRS_SwCluC_00101](#))

[SWS_SwCluC_03158]{DRAFT} [The [Cross Cluster Communication](#) of the [Software Cluster Connection](#) shall make each request queue instance created according to [SWS_SwCluC_03152] accessible to the [Software Cluster](#), via a [Resource Entry](#) in the [Binary Manifest](#).]([SRS_SwCluC_00100](#), [SRS_SwCluC_00101](#))

[SWS_SwCluC_03159]{DRAFT} [The [Cross Cluster Communication](#) of the [Software Cluster Connection](#) shall make each response buffer instance created according to [SWS_SwCluC_03153] accessible to the [Software Clusters](#), via a [Resource Entry](#) in the [Binary Manifest](#).]([SRS_SwCluC_00100](#), [SRS_SwCluC_00101](#))

7.3.5.5 Response to Request Mapping

The [Cross Cluster Communication](#) is responsible to map a response to the corresponding request. The problem of request to response mapping is split into:

- Mapping of a response to the correct client in the [Software Cluster](#).
- Mapping of a response to the correct request within one client in the [Software Cluster](#).

The general approach for request response mapping is to use transaction handles.

[SWS_SwCluC_03160]{DRAFT} [The [Cross Cluster Communication](#) of the [Software Cluster Connection](#) shall use a transaction handle that contains three parts, of unsigned integer type:

- Software Cluster Identifier
- Client Identifier
- Client Sequence Counter

]([SRS_SwCluC_00100](#), [SRS_SwCluC_00103](#))

[SWS_SwCluC_03161]{DRAFT} [The [Cross Cluster Communication](#) of the [Software Cluster Connection](#) shall use the transaction handle for the identification of client server transactions, communicated between the clusters.]([SRS_SwCluC_00100](#), [SRS_SwCluC_00103](#))

[SWS_SwCluC_03162]{DRAFT} [The [Cross Cluster Communication](#) on the server side of the [Software Cluster Connection](#) shall return the transaction handle of the request, without modification, together with the response.]([SRS_SwCluC_00100](#), [SRS_SwCluC_00103](#))

[SWS_SwCluC_03163]{DRAFT} [The [Cross Cluster Communication](#) of the [Software Cluster Connection](#) shall allow only one request per client and server operation at any time.]([SRS_SwCluC_00100](#), [SRS_SwCluC_00103](#))

7.3.5.6 Client Side

[SWS_SwCluC_03086] [The [Cross Cluster Communication](#) of the [Software Cluster Connection](#) shall treat a client as connected

- if the corresponding resource in the [Binary Manifest](#) of the request queue (see [[SWS_SwCluC_03158](#)])

AND

- if the corresponding resource in the [Binary Manifest](#) of the response buffer (see [[SWS_SwCluC_03159](#)])

are connected.]([SRS_SwCluC_00100](#), [SRS_SwCluC_00103](#))

Note: This means that if only the request queue or the response buffer gets a connection to the server in the other [Software Cluster](#), the client is considered as unconnected.

[SWS_SwCluC_03164]{DRAFT} [If the client is not connected according [[SWS_SwCluC_03086](#)], the `Rte_Rips_Invoke` shall return `RTE_E_UNCONNECTED` immediately.]([SRS_SwCluC_00100](#), [SRS_SwCluC_00103](#))

[SWS_SwCluC_03165]{DRAFT} [If the client is connected according [[SWS_SwCluC_03086](#)], the `Rte_Rips_Invoke` shall copy the IN and IN/OUT parameters, inform the server via a status flag, and return `RTE_E_OK`.]([SRS_SwCluC_00100](#), [SRS_SwCluC_00103](#))

[SWS_SwCluC_03166]{DRAFT} [If the client is connected according [[SWS_SwCluC_03086](#)], the `Rte_Rips_Invoke` shall return `RTE_E_LIMIT`, until the server's result has been successfully passed to the client, and no timeout occurred. The IN and IN/OUT parameters shall not be modified by `Rte_Rips_Invoke`.]([SRS_SwCluC_00100](#), [SRS_SwCluC_00103](#))

[SWS_SwCluC_03167]{DRAFT} [If the client is not connected according [[SWS_SwCluC_03086](#)], the `Rte_Rips_ReturnResult` shall return `RTE_E_UNCONNECTED` immediately.]([SRS_SwCluC_00100](#), [SRS_SwCluC_00103](#))

[SWS_SwCluC_03168]{DRAFT} [If the client is connected according [SWS_SwCluC_03086], the `RteRips_ReturnResult` shall return `RTE_E_NO_DATA`, until the server's result has been successfully passed to the client and no timeout occurred.]([SRS_SwCluC_00100](#), [SRS_SwCluC_00103](#))

[SWS_SwCluC_03169]{DRAFT} [If the client is connected according [SWS_SwCluC_03086], and the server's result was not available within the specified timeout, the `RteRips_ReturnResult` shall return `RTE_E_TIMEOUT`.]([SRS_SwCluC_00100](#), [SRS_SwCluC_00103](#))

[SWS_SwCluC_03170]{DRAFT} [If the client is connected according [SWS_SwCluC_03086], and an `AsynchronousServerCallReturnsEvent` exists, the `RteRips_InvocationHandler` shall poll the corresponding response queue status to determine whether or not the server's result is available.]([SRS_SwCluC_00100](#), [SRS_SwCluC_00103](#), [SRS_BSW_00172](#))

[SWS_SwCluC_03171]{DRAFT} [If the client is connected according [SWS_SwCluC_03086], and an `AsynchronousServerCallReturnsEvent` exists, the `RteRips_InvocationHandler` shall call the corresponding `ACSR Runnable`.]([SRS_SwCluC_00100](#), [SRS_SwCluC_00103](#))

7.3.5.7 Server Side

[SWS_SwCluC_03173]{DRAFT} [If the corresponding resource in the `Binary Manifest` representing the request queue (See [SWS_SwCluC_03158]) is connected, the `RteRips_InvocationHandler` shall poll the corresponding request queue status to determine whether or not there is a pending request.]([SRS_SwCluC_00100](#), [SRS_SwCluC_00103](#), [SRS_BSW_00172](#))

[SWS_SwCluC_03401] [One call of the `RteRips_InvocationHandler` shall dequeue pending server call requests until

- either the request queue has no further pending requests

OR

- it has executed so many server calls as given by the configuration 'maximum number of server invocations' according [SWS_SwCluC_03402].

]([SRS_SwCluC_00100](#), [SRS_SwCluC_00103](#))

[SWS_SwCluC_03402] [The `Cross Cluster Communication` of the `Software Cluster Connection` shall determine the 'maximum number of server invocations' value for a `server runnable` from the parameter `RteServerNumberOfRequestProcessing` of the `RteEventToTaskMapping` applied to the `OperationInvokedEvent` of the `server runnable`.]([SRS_SwCluC_00100](#), [SRS_SwCluC_00103](#))

[SWS_SwCluC_03178] [If the

- corresponding resource in the [Binary Manifest](#) representing the request queue (See [[SWS_SwCluC_03158](#)])

AND

- corresponding resource in the [Binary Manifest](#) representing the response buffer (See [[SWS_SwCluC_03159](#)])

are connected, the [Rte_Rips_InvocationHandler](#) shall invoke the corresponding [server runnable](#) with IN, IN/OUT and OUT parameters of request resp. response buffer.] ([SRS_SwCluC_00100](#), [SRS_SwCluC_00103](#))

[SWS_SwCluC_03176]{DRAFT} [If the corresponding resource in the [Binary Manifest](#) representing the request queue (See [[SWS_SwCluC_03158](#)]) is connected, the [Rte_Rips_InvocationHandler](#) shall dequeue the server queue after successful invocation of the server queue.] ([SRS_SwCluC_00100](#), [SRS_SwCluC_00103](#))

[SWS_SwCluC_03177]{DRAFT} [If the corresponding resource in the [Binary Manifest](#) representing the request queue (See [[SWS_SwCluC_03158](#)]) is connected (see [[SWS_SwCluC_03086](#)]), the [Rte_Rips_InvocationHandler](#) shall set the status of the response buffer (See [[SWS_SwCluC_03159](#)]) accordingly, to inform the client that the request has been processed.] ([SRS_SwCluC_00100](#), [SRS_SwCluC_00103](#))

[SWS_SwCluC_03083] [The [Cross Cluster Communication](#) of the [Software Cluster Connection](#) shall ignore server responses with invalid transaction handles on the client side.] ([SRS_SwCluC_00100](#), [SRS_SwCluC_00103](#))

For instance the server responds with a transaction handle which does not match to any ongoing client request.

7.3.6 Modes Communication

7.3.6.1 General principles

The mode switch communication in AUTOSAR is a mixture between a data (the mode value) and an event semantic (the transition between modes). It also has some potential impact on the execution of [ExecutableEntitys](#), via mode switch events and mode disabling dependencies. Additionally, the transitions between modes are following a strict sequence, as described in document [4].

Introducing this communication pattern to a clustered software architecture requires a technical solution that balances between the local view of software components inside a [Software Cluster](#), and the ECU wide behavior cross several [Software Clusters](#).

For the Software Cluster Communication, the following principles apply:

- The mode providing [Software Cluster](#) owns the leading mode machine instance, including the mode queue.

- The [Host Software Cluster](#) provides the mode switch tasks, which are used to execute the mode switch on each partition, where the mode is capable to execute runnables
- The [Host Software Cluster](#) coordinates the transfer of the mode switch notifications between the [Software Clusters](#).
- The [Host Software Cluster](#) coordinates the conjunction of the [Software Cluster](#) individual completions of the mode switches, and notifies the mode providing [Software Cluster](#)
- Nevertheless, the mode switch itself is locally executed in each RTE in a [Software Cluster](#). This has the consequence that the order between [on-exit ExecutableEntitys](#), [on-transition ExecutableEntitys](#), and [on-entry ExecutableEntitys](#) is only preserved locally inside a [Software Cluster](#).
- The interfaces towards the RTE are only called in well-defined OS task contexts.

A sender-receiver communication can be implemented solely between [Application Software Clusters](#), without impact to the [Host Software Cluster](#). In contrast, the adding of a new mode switch communication between [Application Software Clusters](#), additionally impacts the [Host Software Cluster](#).

7.3.6.2 Software Cluster providing a mode

The [Software Cluster](#) providing the mode owns the leading mode machine instance, including its mode queue. Hence, the information about the next mode, to which the mode machine currently switches, is provided by this [Software Cluster](#). In this specification, this mode value is called 'current on-transition value'.

The figure [7.3](#) illustrates the principle sequence, when a mode switch is initiated by an [Application Software Cluster](#).

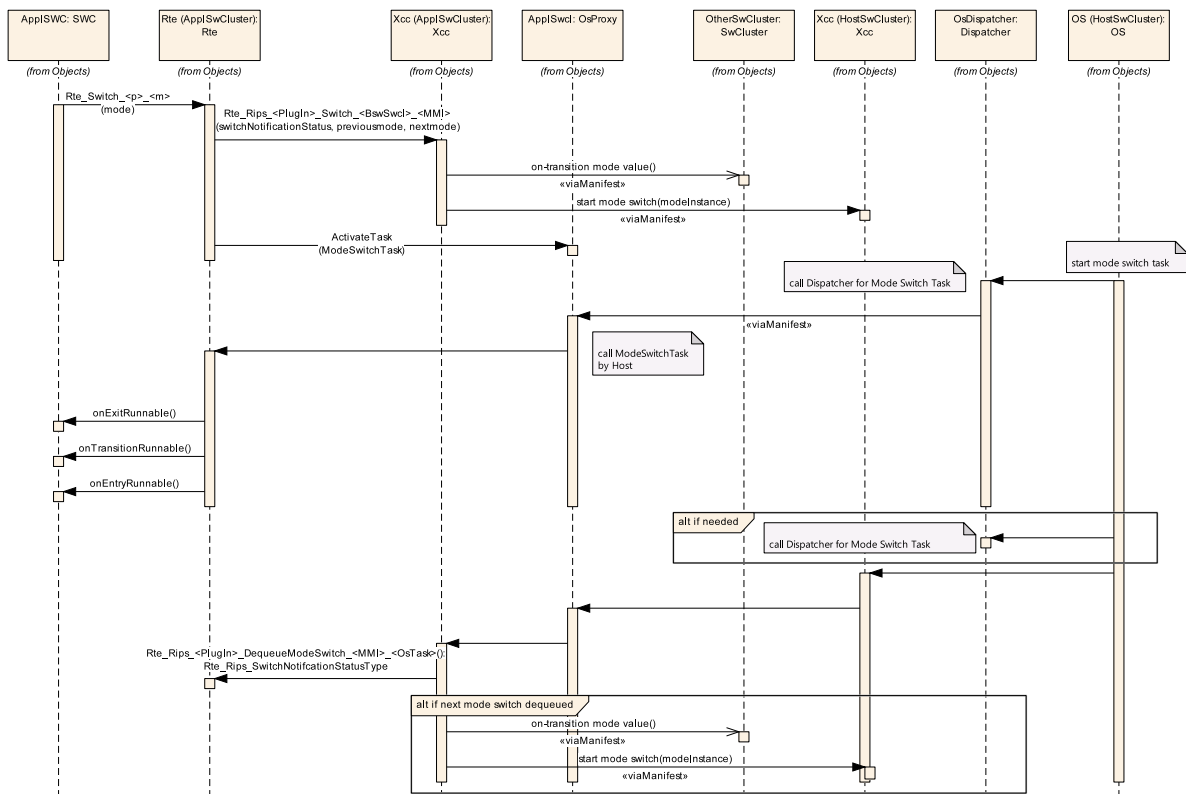

Figure 7.3: Execution of a mode switch provided by an Application Software Cluster

- The **mode manager** software component calls the `Rte_Switch` API to do the mode switch notification
- The **Cross Cluster Communication** gets notified via the call of the `Rte_Rips_Switch` Service.
- If the mode queue is empty, this `Rte_Rips_Switch` can be used to determine the first on-transition value.
- The **Cross Cluster Communication** in the **Application Software Cluster** informs the **Cross Cluster Communication** in the **Host Software Cluster** that a mode switch starts. This notification is a **Cross Cluster Communication** internal interface, which is not standardized.
- After the start of the mode switch on the host, the according mode switch tasks are scheduled (potentially on multiple partitions). This in turn, via `Dispatchers`, schedules cluster local proxy mode switch tasks.
- Potentially, other proxy mode switch tasks are scheduled before and after. Hence, the RTE cannot dequeue the next mode already in the context of its mode switch tasks.
- After the **Cross Cluster Communication** in the **Host Software Cluster** has determined that a mode switch task has run to end, it uses **Cross**

Cluster Communication to notify the RTE in the Application Software Cluster to dequeue the next mode.

The figure 7.4 illustrates the principle sequence, when a mode switch is initiated by a Host Software Cluster.

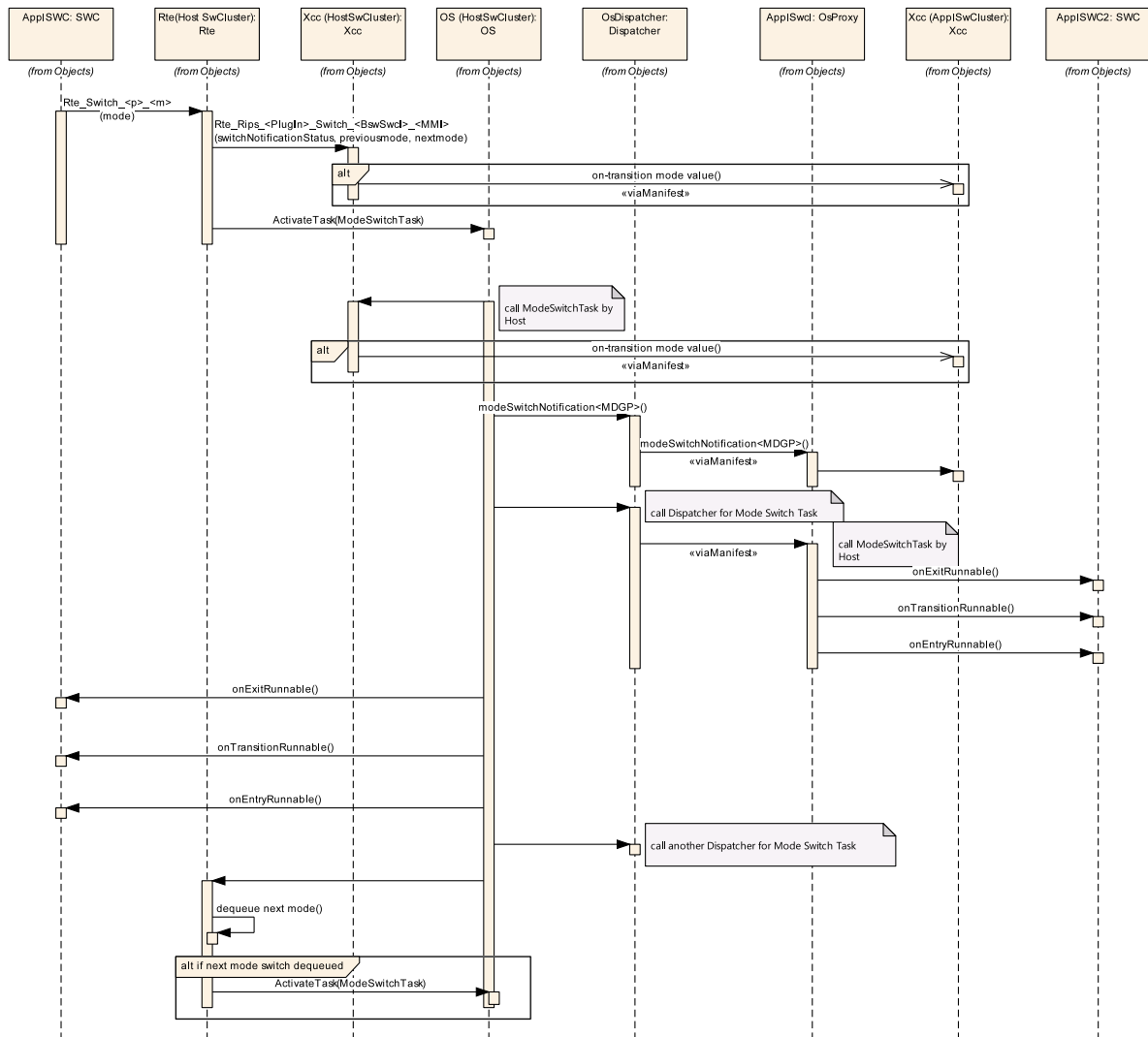

Figure 7.4: Execution of a mode switch provided by an Host Software Cluster

- The mode manager software component calls the Rte_Switch API, to do the mode switch notification
- The Cross Cluster Communication gets notified via the call of the Rte_Rips_Switch Service.
- If the mode queue is empty, this Rte_Rips_Switch can be used to determine the first on-transition value. Alternatively, this is also possible in the mode switch task(s) before first Dispatchers are scheduled.

- After the start of the mode switch on the host, the according mode switch tasks are scheduled (potentially on multiple partitions). This in turn, via `Dispatchers`, schedules cluster local proxy mode switch tasks.
- In contrast to the scenario in figure 7.3, the RTE can dequeue the next mode already in the context of its mode switch tasks.

These two principle sequences lead to the following requirements on the `Cross Cluster Communication`, in case a `Software Cluster` provides a mode.

[SWS_SwCluC_03022]{DRAFT} [The `Cross Cluster Communication` shall signal the current on-transition value to other `Software Clusters`, before the mode switch according to [SWS_Rte_02665] starts.](*SRS_SwCluC_00104*)

Note: This functionality can be implemented inside the `Rte_Rips_Switch` service, in case the mode queue was empty. Otherwise, this can be done shortly before the last mode switch task terminates, or when the first mode switch task starts already for the next transition. The interface to signal the current on-transition is a `Cross Cluster Communication` internal interface, which is not standardized.

[SWS_SwCluC_03057]{DRAFT} [The `Cross Cluster Communication` shall add at the `Software Cluster` providing the mode a `Provided Resource Entry`, and at any `Software Cluster` requiring the trigger an according `Require Resource Entry` in the `Binary Manifest`.](*SRS_SwCluC_00104*)

[SWS_SwCluC_03057] ensures that a missing `mode manager` in a clustered ECU gets detected, even if the implementation may rely additionally on the according `Dispatchers`.

[SWS_SwCluC_03023]{DRAFT} [The `Cross Cluster Communication` of the `Host Software Cluster` shall implement a `mode manager` for each mode which needs to be provided by an `Application Software Cluster`.](*SRS_SwCluC_00104*)

With this `mode manager`, it is possible to schedule the according `Dispatchers` for mode switch notification, and `Dispatchers` for `Software Cluster` local proxy mode switch tasks.

To ease the realization of [SWS_SwCluC_03023], all modes provided by the `Application Software Clusters`, shall be consumed by the `Host Software Cluster`.

[SWS_SwCluC_CONSTR_03032]{DRAFT} [For each mode provided by an `Application Software Cluster`, the `Ecu Extract` of the `Host Software Cluster` shall own a required `mode switch port` at the `CompositionSwComponentType` of the `rootSoftwareComposition`.](*SRS_SwCluC_00104*)

[SWS_SwCluC_03024]{DRAFT} [The `Cross Cluster Communication` of the `Host Software Cluster` shall enqueue the current on-transition values signaled by `Application Software Cluster`, via the related `mode manager`. ([SWS_SwCluC_03023])](*SRS_SwCluC_00104*)

Note: In case the [Host Software Cluster](#) provides the mode, the RTE implements already the leading mode machine instance.

[SWS_SwCluC_03025]{DRAFT} [The [Cross Cluster Communication](#) of the [Host Software Cluster](#) shall notify the [Application Software Cluster](#), when a mode switch tasks starts.] ([SRS_SwCluC_00104](#))

Note: This notification is used by the [Application Software Cluster](#) to schedule the [mode switch notification](#) runnable, which enqueues the mode switch notification in the cluster local RTE.

[SWS_SwCluC_03026]{DRAFT} [The [Cross Cluster Communication](#) of the [Host Software Cluster](#) shall notify the [Cross Cluster Communication](#) of the [Application Software Cluster](#), when all mode switch tasks run to end.] ([SRS_SwCluC_00104](#))

[SWS_SwCluC_03027]{DRAFT} [In case the [Application Software Cluster](#) provides the mode, the [Cross Cluster Communication](#) of the [Host Software Cluster](#) shall notify the [Cross Cluster Communication](#) of the [Application Software Cluster](#), when mode switch tasks run to end.] ([SRS_SwCluC_00104](#))

[SWS_SwCluC_03028]{DRAFT} [In case the [Application Software Cluster](#) provides the mode, the [Cross Cluster Communication](#) of the [Application Software Cluster](#) notifies the RTE via [Rte_Rips_DequeueModeSwitch](#), when a mode switch task known by this RTE runs to end. The [Cross Cluster Communication](#) has to guarantee that the last call of [Rte_Rips_DequeueModeSwitch](#) is not done before the last on-entry [ExecutableEntity](#) in the whole clustered system terminated.] ([SRS_SwCluC_00104](#))

Please note [\[SWS_Rte_70123\]](#), which guarantees a certain execution context for the RTE.

[SWS_SwCluC_03029]{DRAFT} [The [Cross Cluster Communication](#) shall provide a [Complex Driver Software Component](#) on each [EcucPartition](#), where mode switch task are configured. This component is later called [mode proxy component](#).] ([SRS_SwCluC_00104](#))

[SWS_SwCluC_03030]{DRAFT} [The [Cross Cluster Communication](#) shall provide [RunnableEntity](#)s to detect the start and end of any mode switch task, which is related to mode communication cross [Software Clusters](#).] ([SRS_SwCluC_00104](#))

Please note: the [RunnableEntity](#)s [\[SWS_SwCluC_03030\]](#) may require additional [ModeAccessPoints](#), as well as suitable [RTEEvents](#). It is possible to use [OsTaskExecutionEvent](#) and a small runtime logic, to determine the ongoing mode transition, or a set of [SwcModeSwitchEvents](#), which activate the [RunnableEntity](#) on any transition of a specific mode machine instance.

7.3.6.3 Host Software Cluster requiring a mode

As explained in section 7.3.6.2, the [Host Software Cluster](#) is already aware about existing modes communicated cross [Software Clusters](#). Therefore, it technically receives already the modes provided by [Application Software Clusters](#). In case the [Host Software Cluster](#) owns software components, which require the the mode as well, it shall connect them to its already existing mode manager.

[SWS_SwCluC_03031]{DRAFT} [The [Cross Cluster Communication](#) shall provide the [AssemblySwConnectors](#) between the provided [mode switch ports](#) of the [mode proxy component](#) and the required [mode switch ports](#) at the software components requiring the mode, if the mode is required by the [Host Software Cluster](#).] ([SRS_SwCluC_00104](#))

7.3.6.4 Application Software Cluster requiring a mode

For each required mode, the [Application Software Cluster](#) defines [OsTask\(s\)](#) plus [dispatcher\(s\)](#), for the [mode switch notification](#).

When the mode switch gets notified by the [Host Software Cluster](#), the [Cross Cluster Communication](#) writes the actual on-transition mode value to the RTE of the [Application Software Cluster](#) with the regular [Rte_Switch](#) API related to a [mode switch port](#).

Note: The RTE in the [Application Software Cluster](#) shall still a call [ActivateTask\(s\)](#) to trigger the mode switch task(s). This call can still be used by the [Host Software Cluster](#) to trigger the mode switch task execution in the [Host Software Cluster](#), if needed.

For this purpose, the [Cross Cluster Communication](#) defines a [RunnableEntity](#) with an [OsTaskExecutionEvent](#) for each mode on each partition where a [mode switch notification](#) is configured. When the mode switch is executed, the [Host Software Cluster](#) schedules the mode switch task(s), which in turn schedule the 'proxy' mode switch task(s) in the [Application Software Cluster](#)

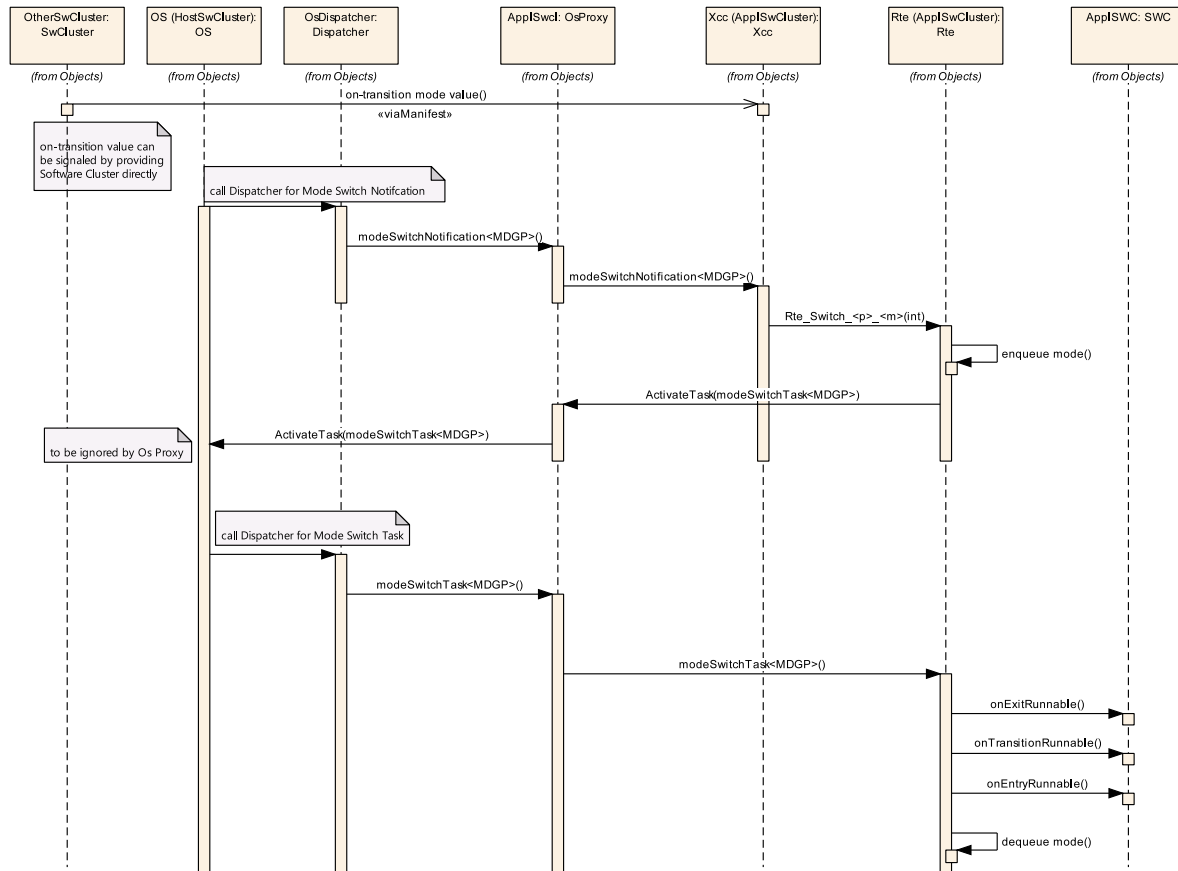

Figure 7.5: Execution of a mode switch in an Application Software Cluster

[SWS_SwCluC_03015]{DRAFT} [The Cross Cluster Communication shall provide a Complex Driver Software Component on each EcucPartition where a mode switch port needs to be provided. This component is later called mode proxy component.] (SRS_SwCluC_00104)

[SWS_SwCluC_03016]{DRAFT} [The Cross Cluster Communication shall provide a provided mode switch port on each mode proxy component where a mode switch port needs to be provided.] (SRS_SwCluC_00104)

[SWS_SwCluC_03017]{DRAFT} [The Cross Cluster Communication shall provide the AssemblySwConnectors between the provided mode switch ports and the required mode switch ports at the software components requiring the mode.] (SRS_SwCluC_00104)

[SWS_SwCluC_03018]{DRAFT} [The Cross Cluster Communication shall provide a mode switch notification runnable with an OsTaskExecutionEvent, for each mode on each partition where a mode switch notification is configured. The RunnableEntity shall define a ModeSwitchPoint.] (SRS_SwCluC_00104)

[SWS_SwCluC_03019]{DRAFT} [When the mode switch notification `runnable` is executed, it shall write the actual on-transition value via `Rte_Switch` to the RTE.]([SRS_SwCluC_00104](#))

[SWS_SwCluC_CONSTR_03020]{DRAFT} [For each `EcucPartition` on which the mode switch notification is configured for a `ModeDeclarationGroupPrototype` required by an `Application Software Cluster`, a `OsTask` with a related `SwCluCOsProxyOsTask` and `SwCluCOsProxyOsTaskDispatcher` shall be configured.]([SRS_SwCluC_00104](#))

[SWS_SwCluC_CONSTR_03021]{DRAFT} [For each required `ModeDeclarationGroupPrototype` and `EcucPartition` on which the mode switch notification is configured, a `OsTask` with a related `SwCluCOsProxyOsTask` and `SwCluCOsProxyOsTaskDispatcher` shall be configured.]([SRS_SwCluC_00104](#))

7.3.6.5 Initialization

The approach described in section 7.3.6.2 and 7.3.6.4 leads to local mode machine instances in each `Software Cluster` providing or requiring the mode.

But this also implies that the initialization of the mode machine instances is executed time shifted, without explicit synchronization by the `Cross Cluster Communication`.

When the clustered system starts, the following procedure needs to be preserved!

- Initialization of the `Cross Cluster Communications`
- Execute all `Rte_Init_<InitContainer>` functions in `Application Software Clusters` and `Host Software Cluster`. This step already leads to the execution of `on-entry ExecutableEntitys`, triggered by `initialMode` and mapped to `RteInitializationRunnableBatch` container.
- Execute all `Rte_Start` in `Application Software Clusters`. This step executes the remaining `on-entry ExecutableEntitys` triggered by `initialMode`. In case the RTE implementation triggers the mode switch task to proceed the transition to the `initialMode`, it will happen here as well.
- Execute `Rte_Start` in the `Host Software Cluster`. This step executes the remaining `on-entry ExecutableEntitys` triggered by `initialMode` in the `Host Software Cluster`. In case the RTE implementation triggers the mode switch task to proceed the transition to the `initialMode`, the mode switch task will now be executed.

7.3.7 Trigger Communication

7.3.7.1 General principles

The trigger communication in AUTOSAR is a pure event semantic, which is used to request the execution of `triggered ExecutableEntitys`.

Introducing this communication pattern to a clustered software architecture, the focus lies on the use case to implement `trigger sources` in `Application Software Clusters` and in the `Host Software Cluster`. Nevertheless, the control on the execution of the `triggered ExecutableEntitys` is implemented in the `Host Software Cluster`, to guarantee an ECU wide behavior cross several `Software Clusters`.

For the `Software Cluster Communication`, the following principles apply:

- The trigger providing `Application Software Cluster` transfers the occurrence of the trigger to the `Host Software Cluster`.
- The `Host Software Cluster` provides the tasks, which are used to execute the `triggered ExecutableEntitys` on each partition where needed.
- If queuing of triggers is required from a dynamic perspective, this is configured and implemented in the RTE of the `Host Software Cluster`
- Nevertheless, the triggering itself is locally executed in each RTE inside a `Software Cluster`. This has the consequence that the order between `triggered ExecutableEntitys` is only preserved locally inside a single proxy OS Task of an `Application Software Cluster`.
- The interfaces towards the RTE are only called in well-defined OS task contexts.

Adding of a new trigger communication between `Application Software Clusters`, additionally impacts the `Host Software Cluster`.

7.3.7.2 Software Cluster providing a trigger

The figure 7.6 illustrates the principle sequence, when a trigger is raised by an `Application Software Cluster`.

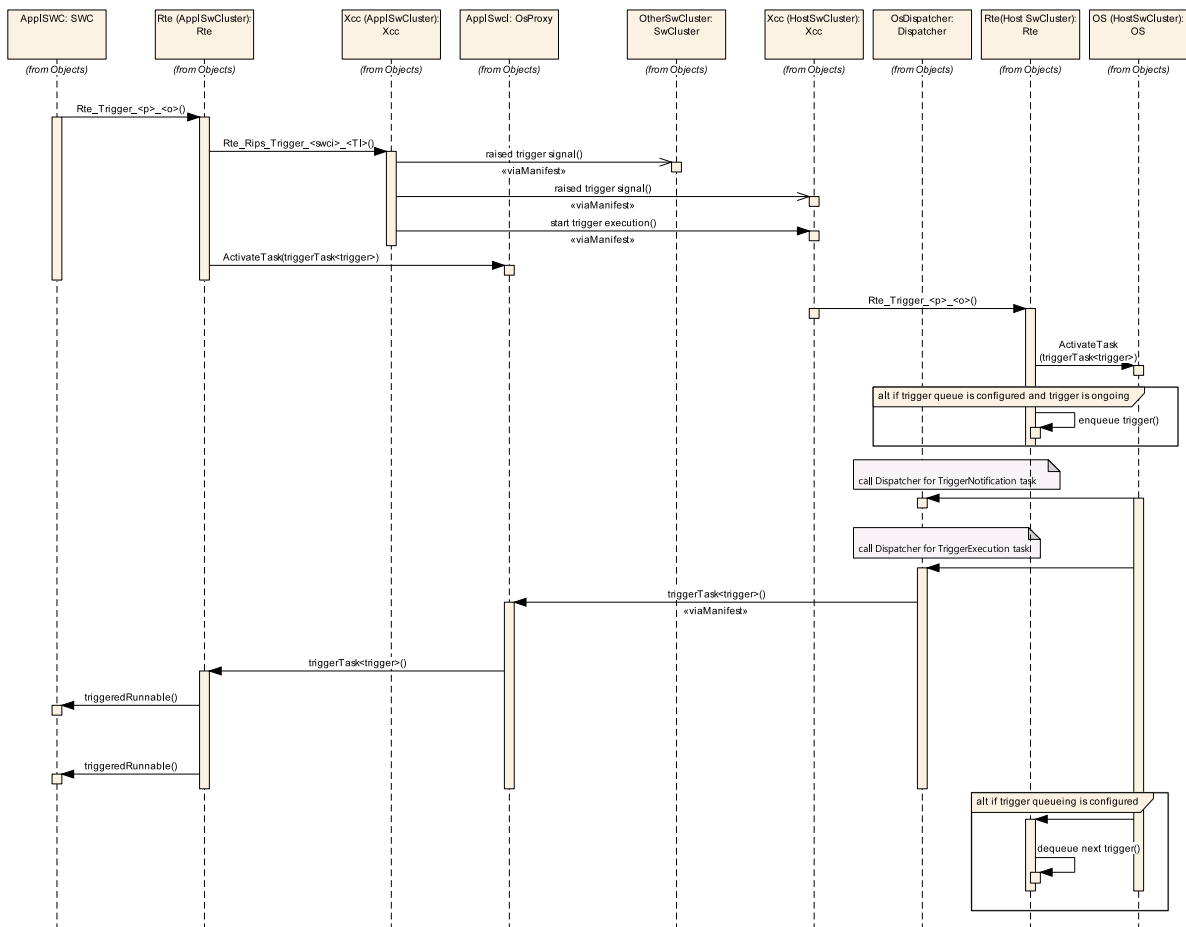

Figure 7.6: Execution of a trigger provided by an Application Software Cluster

- The `trigger source` calls the `Rte_Trigger` API, to raise the trigger.
- The `Cross Cluster Communication` gets notified, via the call of the `Rte_Rips_Trigger` Service.
- The `Cross Cluster Communication` in the `Application Software Cluster` informs the `Cross Cluster Communication` in the `Host Software Cluster` that a trigger was raised. This notification is a `Cross Cluster Communication` internal interface, which is not standardized.
- In the `Host Software Cluster`, the `Cross Cluster Communication` raises the trigger in the RTE, via `Rte_Trigger` API. In case of a configured trigger queue, this would enqueue the trigger.
- After the start of the trigger execution on the `Host Software Cluster`, the according tasks are scheduled (potentially on multiple partitions). This in turn schedules, via `Dispatchers`, the `Application Software Cluster` local proxy tasks.
- In case of a configured trigger queue, the dequeue operation is executed after the last `triggered ExecutableEntity` terminated.

The figure 7.7 illustrates the principle sequence, when a trigger is raised by a [Host Software Cluster](#).

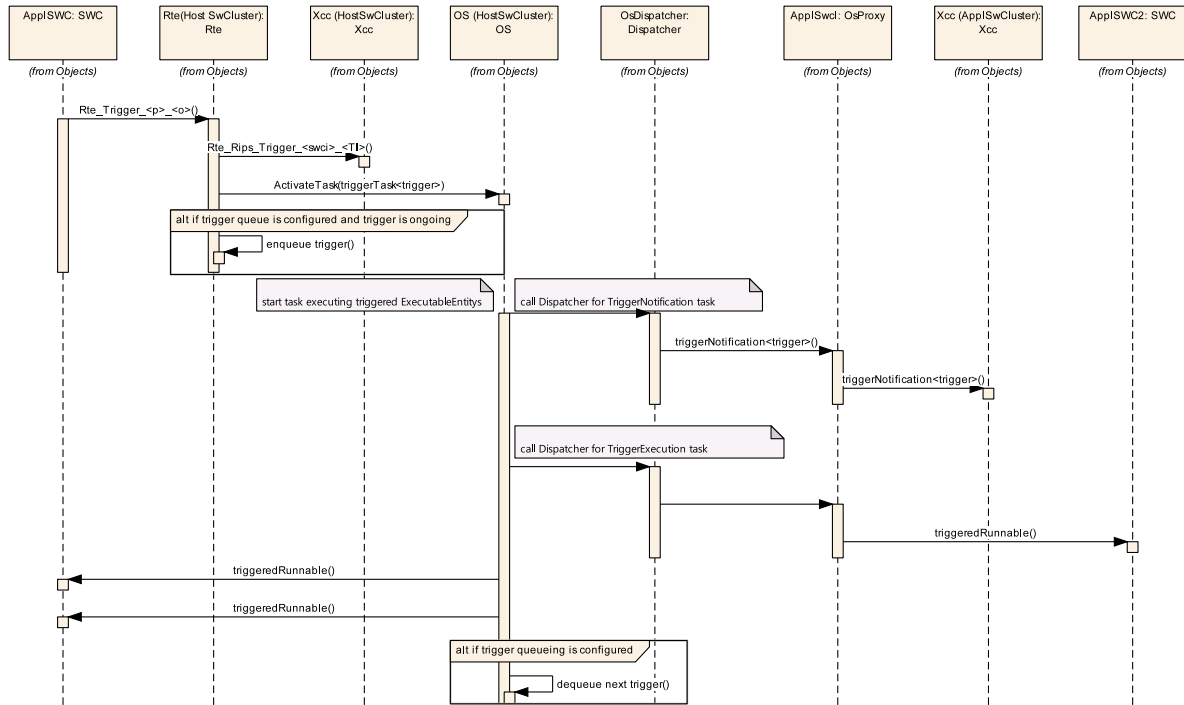

Figure 7.7: Execution of a trigger provided by an Host Software Cluster

- The [trigger source](#) calls the `Rte_Trigger` API, to raise the trigger.
- The [Cross Cluster Communication](#) gets notified, via the call of the `Rte_Rips_Trigger` Service.
- The RTE activates the tasks used for execution of [triggered ExecutableEntities](#). If a queue is configured, and a trigger execution is already ongoing, the RTE in the [Host Software Cluster](#) enqueues the trigger.
- After the start of the trigger execution on the [Host Software Cluster](#), the according tasks are scheduled (potentially on multiple partitions). This in turn, schedules, via Dispatchers, the [Application Software Cluster](#) local proxy tasks.
- In case of a configured trigger queue, the dequeue operation is executed after the last [triggered ExecutableEntities](#) terminated.

These two principle sequences lead to the following requirements on the [Cross Cluster Communication](#), in case a [Software Cluster](#) provides a mode.

[SWS_SwCluC_03055]{DRAFT} [The [Cross Cluster Communication](#) shall signal to other [Software Clusters](#) that a trigger was raised.] ([SRS_SwCluC_00105](#))

Note: This functionality can be implemented inside the `Rte_Rips_Trigger` service. Function wise, it is up to the implementation, if the `[SWS_SwCluC_03055]` is already fulfilled via the connection to the `Host Software Cluster`.

[SWS_SwCluC_03056]{DRAFT} [The `Cross Cluster Communication` shall, at the `Software Cluster` providing the trigger, add a `Provided Resource Entry` and, at `Software Clusters` requiring the trigger, an according `Require Resource Entry` in the `Binary Manifest`.] (*SRS_SwCluC_00105*)

`[SWS_SwCluC_03056]` ensures that a missing `trigger source` in a clustered ECU gets detected, even if the implementation may rely on the according `Dispatchers`.

[SWS_SwCluC_03058]{DRAFT} [The `Cross Cluster Communication` of the `Host Software Cluster` shall implement a `trigger source` for each trigger, which needs to be provided by an `Application Software Cluster`.] (*SRS_SwCluC_00105*)

With this `trigger source`, it is possible to schedule the according `Dispatchers` for trigger notification, and `Dispatchers` for `Software Cluster` local trigger execution tasks.

To ease the realization of `[SWS_SwCluC_03058]`, all triggers provided by `Application Software Clusters`, shall be consumed by the `Host Software Cluster`.

[SWS_SwCluC_CONSTR_03059]{DRAFT} [The `Ecu Extract` of the `Host Software Cluster` shall, for each trigger provided by an `Application Software Cluster`, own a required `trigger port` at the `CompositionSwComponentType` of the `rootSoftwareComposition`.] (*SRS_SwCluC_00105*)

[SWS_SwCluC_03060]{DRAFT} [The `Cross Cluster Communication` of the `Host Software Cluster` shall raise the triggers signaled by `Application Software Clusters`, via the related `trigger source`. (`[SWS_SwCluC_03058]`)] (*SRS_SwCluC_00105*)

Note: In case the `Host Software Cluster` provides the trigger, the `trigger source` is already part of the `Software Components` or `BSW Modules` belonging to the `Host Software Cluster`, which are directly interacting with the `RTE` or `SchM`.

[SWS_SwCluC_03061]{DRAFT} [The `Cross Cluster Communication` of the `Host Software Cluster` shall notify the `Application Software Cluster`, when the execution of a trigger tasks starts.] (*SRS_SwCluC_00104*)

Note: This notification is used by the `Application Software Cluster` to schedule the `trigger notification runnable`, which raises the trigger at the cluster local `RTE`.

[SWS_SwCluC_03062]{DRAFT} [The `Cross Cluster Communication` shall provide a `Complex Driver Software Component` on each `EcucPartition`, where a `trigger source` according to `[SWS_SwCluC_03058]` is configured. This component is later called `trigger proxy component`.] (*SRS_SwCluC_00104*)

7.3.7.3 Host Software Cluster requiring a trigger

As explained in section 7.3.7.2, the `Host Software Cluster` is already aware about an existing trigger communicated cross `Software Clusters`. Therefore, it technically already receives the triggers raised by `Application Software Clusters`. In case the `Host Software Cluster` owns software components that require the the trigger as well, it shall connect them to its already existing `trigger source`, according to [SWS_SwCluC_03058].

[SWS_SwCluC_03063]{DRAFT} [The `Cross Cluster Communication` shall provide the `AssemblySwConnectors` between the provided `trigger ports` of the `trigger proxy component`, and the required `trigger ports` at the software components requiring the trigger, if the trigger is required by the `Host Software Cluster`.](SRS_SwCluC_00104)

7.3.7.4 Application Software Cluster requiring a trigger

For each required `trigger`, the `Application Software Cluster` defines `OsTask(s)` plus `dispatcher(s)`, for the `trigger notification`.

When the trigger gets executed by the `Host Software Cluster`, the `Cross Cluster Communication` raises `trigger` at the RTE of the `Application Software Cluster`, with the regular `Rte_Trigger` API related to a `trigger port`.

Note: The RTE in the `Application Software Cluster` shall still call `ActivateTask(s)`, to trigger the task(s) used for the execution of `triggered ExecutableEntities`. This call can still be used by the `Host Software Cluster` to trigger the task executions in the `Host Software Cluster`, if needed.

For this purpose, the `Cross Cluster Communication` defines a `RunnableEntity` with an `OsTaskExecutionEvent`, for each trigger and on each partition, a `trigger notification` is configured. When the trigger is executed, the `Host Software Cluster` schedules the task(s), which in turn schedule the 'proxy' task(s) in the `Application Software Cluster`.

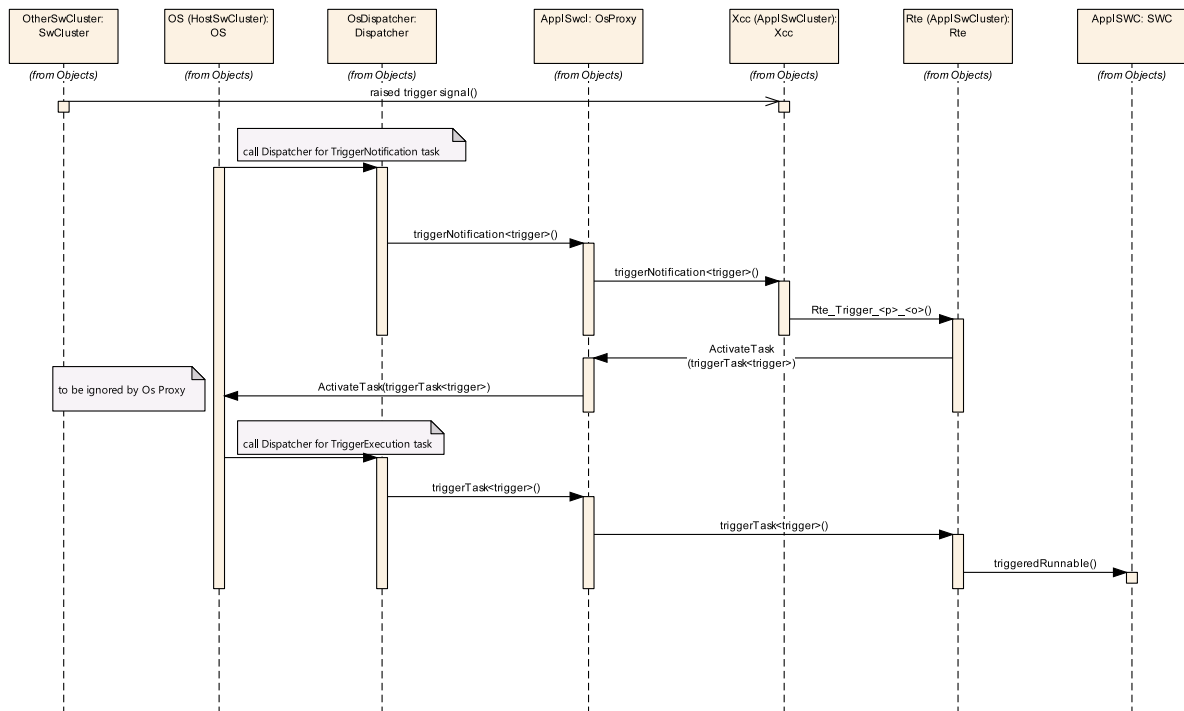

Figure 7.8: Execution of a trigger in an Application Software Cluster

[SWS_SwCluC_03048]{DRAFT} [The Cross Cluster Communication shall provide a Complex Driver Software Component, on each EcucPartition where a trigger port needs to be provided. This component is later called trigger proxy component.](SRS_SwCluC_00105)

[SWS_SwCluC_03049]{DRAFT} [The Cross Cluster Communication shall provide a provided trigger port, on each trigger proxy component.](SRS_SwCluC_00105)

[SWS_SwCluC_03050]{DRAFT} [The Cross Cluster Communication shall provide the AssemblySwConnectors between the provided trigger ports and the required trigger ports, at the software components requiring the trigger.](SRS_SwCluC_00105)

[SWS_SwCluC_03051]{DRAFT} [The Cross Cluster Communication shall provide a trigger notification runnable with an OsTaskExecutionEvent, for each trigger on each partition a trigger notification is configured. The RunnableEntity shall define a ExternalTriggeringPoint.](SRS_SwCluC_00105)

[SWS_SwCluC_03052]{DRAFT} [When the trigger notification runnable is executed, it shall raise the trigger via Rte_Trigger to the RTE.](SRS_SwCluC_00105)

[SWS_SwCluC_CONSTR_03053]{DRAFT} [For each `EcucPartition` on which the trigger notification is configured for a `trigger` required by an `Application Software Cluster`, a `OsTask`, with a related `SwCluCOsProxyOsTask` and `SwCluCOsProxyOsTaskDispatcher`, shall be configured.] ([SRS_SwCluC_00105](#))

[SWS_SwCluC_CONSTR_03054]{DRAFT} [For each required `trigger` and `EcucPartition` on which `triggered ExecutableEntitys` needs to be executed, at least one `OsTask`, with a related `SwCluCOsProxyOsTask` and `SwCluCOsProxyOsTaskDispatcher`, shall be configured.] ([SRS_SwCluC_00105](#))

7.3.8 Parameter Communication

[SWS_SwCluC_03006]{DRAFT} [The `Cross Cluster Communication` of the `Software Cluster Connection` shall provide one constant default parameter instance for each assigned `Parameter Communication Graph`, which contains `NO PPortPrototype`.] ([SRS_SwCluC_00100](#), [SRS_SwCluC_00106](#))

[SWS_SwCluC_03007]{DRAFT} [The default value instance shall be mapped to a `CALPRM` memory section, according to document [17].] ([SRS_SwCluC_00100](#), [SRS_SwCluC_00106](#))

Please note as well section [7.3.2.4](#), which is relevant for calibration parameters instantiated by `Software Cluster Connection`.

[SWS_SwCluC_03008]{DRAFT} [The default value instance shall be initialized according to the `ParameterRequireComSpec.initValue`, in the `RPortPrototype` at the `CompositionSwComponentType` of the `rootSoftwareComposition` of the `Ecu Extract`.] ([SRS_SwCluC_00100](#), [SRS_SwCluC_00106](#))

[SWS_SwCluC_03009]{DRAFT} [If the corresponding resource in the `Binary Manifest` is connected, the `Rte_Rips_Prm` shall return the value of the connected parameter.] ([SRS_SwCluC_00100](#), [SRS_SwCluC_00106](#))

[SWS_SwCluC_03010]{DRAFT} [If the corresponding resource in the `Binary Manifest` is NOT connected, the `Rte_Rips_Prm` shall return the value of the default parameter instance of [[SWS_SwCluC_03006](#)].] ([SRS_SwCluC_00100](#), [SRS_SwCluC_00106](#))

Note: The behavior of `Rte_Rips_Prm` function, according to [[SWS_SwCluC_03009](#)] and [[SWS_SwCluC_03010](#)], can be implemented by referencing the default parameter instance as the default handle in the `Binary Manifest`.

[SWS_SwCluC_03011]{DRAFT} [For each assigned `Parameter Communication Graph`, which contains the `PPortPrototype`, the `Cross Cluster Communication` of the `Software Cluster Connection` shall make the parameter instance, according to [[SWS_Rte_80130](#)], accessible for other `Software Clusters`, via a `Resource Entry` in the `Binary Manifest`.] ([SRS_SwCluC_00100](#), [SRS_SwCluC_00106](#))

7.3.9 Error Classification

Together with the RTE, the [Cross Cluster Communication](#) of the [Software Cluster Connection](#) implements the Run-Time Environment of the [Software Cluster](#). The usual development errors checking API parameters are already covered by the development error detection of RTE. In addition, communication infrastructure errors are not reported as [Production Errors](#) nor as [Extended Production Errors](#). Therefore, the following sections do not define error codes, and are marked as not applicable.

7.3.9.1 Development Errors

Development errors are not applicable for the [Cross Cluster Communication](#) of the [Software Cluster Connection](#).

7.3.9.2 Runtime Errors

Runtime errors are not applicable for the [Cross Cluster Communication](#) of the [Software Cluster Connection](#).

7.3.9.3 Transient Faults

Transient Faults are not applicable for the [Cross Cluster Communication](#) of the [Software Cluster Connection](#).

7.3.9.4 Production Errors

Production Errors are not applicable for the [Cross Cluster Communication](#) of the [Software Cluster Connection](#).

7.3.9.5 Extended Production Errors

Extended Production Errors are not applicable for the [Cross Cluster Communication](#) of the [Software Cluster Connection](#).

7.4 Proxy Modules

7.4.1 Overview

Since an [Application Software Cluster](#) does not contain all BSW modules (in extreme case no BSW modules), those missing APIs, as well as the EcuC configuration elements, need to be substituted.

In the AUTOSAR Layered Software Architecture, the dependency between BSW modules can be generalized as follows:

A higher layer BSW module uses the APIs of a lower layer BSW module. In the opposite direction, the lower layer BSW module may call callback functions of the higher layer BSW module. In case of [AUTOSAR Interfaces](#), additional Software Component Descriptions are required to enable the RTE generation. If the interface between those BSW modules is configurable, the ECU configuration provides the information about Symbolic Name values and ID values.

Of course, the AUTOSAR Layered Software Architecture also has horizontal dependencies. In this case, rotate the previous paragraph by 90 degrees.

It is important to state that the different BSW Module are directly using the C-interfaces of each other, without abstraction (as the RTE provides between SWCs). This, in turn, causes strong implementation dependencies, like fixed names of include files and C-functions.

Since the actual implementation and integration of the Classic Platform architecture is now split into Software Clusters, missing BSW Modules - those to which interfaces are existing - need to be substituted. The [Figure 7.9](#) illustrates the proxy module approach, for a horizontal interface dependency.

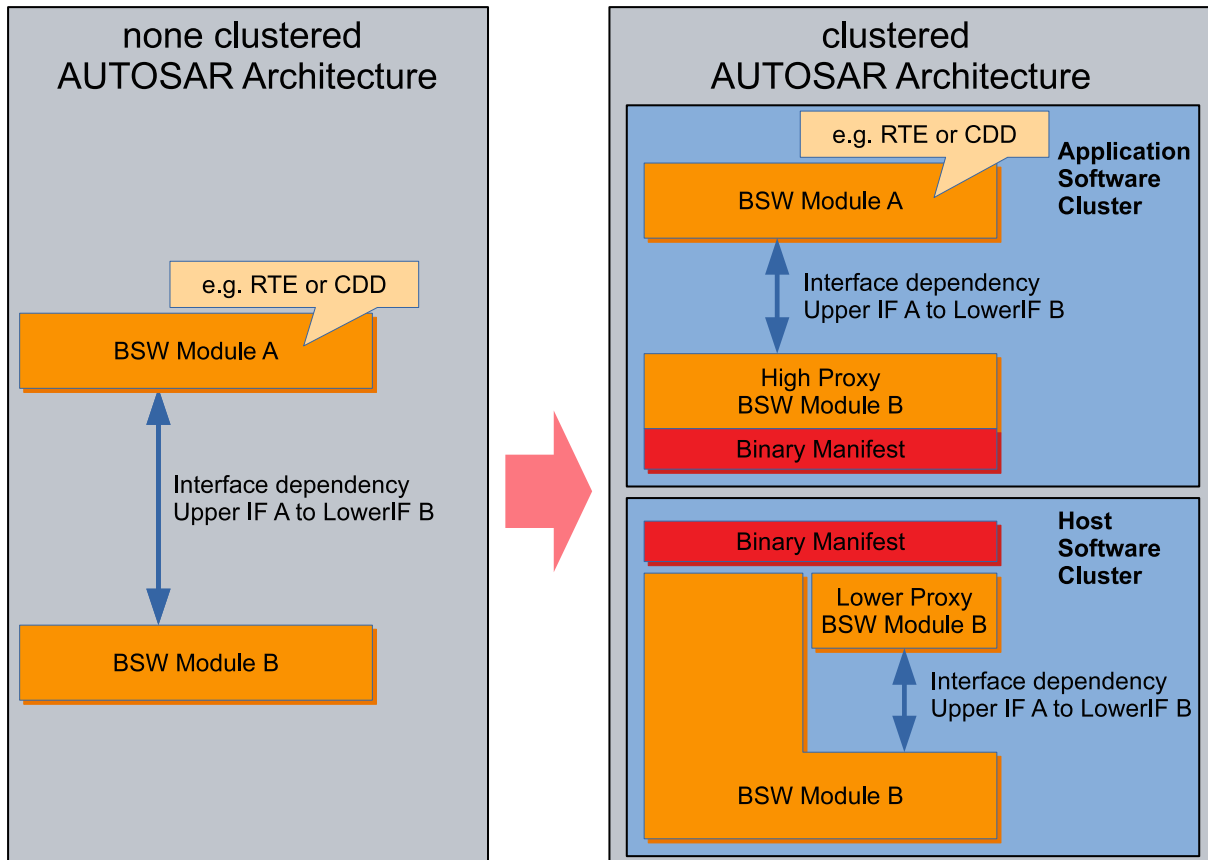

Figure 7.9: Proxy module approach

The C-interfaces of the lower layer BSW module (Module B), towards the higher layer BSW module (Module A), are provided by the High Proxy Module B, in the Software Cluster SWCL 1. The C-interfaces, ECU-C, and Component Descriptions of Module B are provided in the same name space / ARPackage structure as the original Module B. For the users of Module B (in this example Module A), the substitution of Module B by the High Proxy Module B is transparent. Usually, the offered API functions are almost without logic, and are just redirecting the calls towards the substituted module.

In the *Host Software Cluster*, the Low Proxy Module acts as a substitute for all 'user modules' in other Software Clusters. It implements the callback functions, which are normally configured in Module B.

The High Proxy Module and Low Proxy Module are connected via the means of the *Binary Manifest*. Therefore, the functions of the High and Low Proxy modules may contain functionality, which handles this *Binary Manifest* link and the situations if the link is missing. For instance, returning a reasonable error code or even providing some replacement value.

In addition, the High Proxy Module can implement functionality to localize configuration decisions. For instance, in order to support a SWCL local growing of the NV block over integration steps, it could be possible to adjust the locally used size of a NV block. Of course, this is only possible if the configured size in the real NvM is sufficiently large.

By this approach, the SWCs and BSW modules inside the [Application Software Clusters](#) call the common BSW inside the [Host Software Cluster](#) via proxies. When doing so, the partitioning of the ECU SW has to be considered, as described in section [7.4.2.2](#) Partitions.

This section specifies the general Proxy Module pattern. Additionally, requirements for specific Proxy Modules are in section [7.4.3](#). Additional Proxy Modules might be standardized by AUTOSAR in future releases.

7.4.2 Abstract Proxy Module Pattern

This section provides some generic design principles and common requirements, relevant for Proxy Module implementations.

Basically, a High Proxy Module provides a kind of facade, which hides the Software Cluster Connection specific mechanisms to access the real BSW Module. In the AUTOSAR Architecture, such a facade has to hide dependencies to

- Standardized Interfaces
- Standardized AUTOSAR Interfaces and the
- ECU Configuration

In addition to the essential need to provide the interfaces to the BSW Module user in the [Application Software Cluster](#), the [Proxy Module](#) should implement abstraction functionalities. Those abstraction functionalities decouple the needed configuration in the [High Proxy Module](#), from the configuration done in the BSW Module of the [Host Software Cluster](#). The introduction of abstraction functionalities is a case-by-case decision. On the one hand, they might need a functional support of the according BSW Module, or might lead to functional restrictions. On the other hand, such abstractions are beneficial, since in some cases they can be used to avoid a re-configuration of the [Host Software Cluster](#), after change in the [Application Software Cluster](#).

Please note that the following requirements only have limited applicability to an OS Proxy, since the OS APIs are already designed to be called from all the partitions.

7.4.2.1 General Proxy functionality

[SWS_SwCluC_02000]{DRAFT} [The Proxy Module shall support that id values, required to access the BSW service API of the [Host Software Cluster](#), can change, without reconfiguration or rebuild of the [Application Software Cluster](#) using the BSW service.]([SRS_SwCluC_00203](#))

7.4.2.2 Partitions

Partitions are shared between the [Host Software Cluster](#) and [Application Software Clusters](#). This also applies to the properties of the related [OsApplications](#) and [OsTasks](#). Consequently, [Application Software Clusters](#) are not strictly separated from the [Host Software Cluster](#). Due to performance reasons, it is possible to share the identical partition of the [Host Software Cluster](#) with many [Application Software Clusters](#). If [Application Software Clusters](#) share the same partition, they are also not strictly separated from each other. In contrast, if a [Software Cluster](#) has multiple partitions (e.g. on different safety levels), those partitions are separated from each other.

When a partition crossing function call is required, usually some close interaction with the Operating System is necessary - especially in case of different safety levels. However, the Operating System is not directly available inside an [Application Software Cluster](#). Additionally, it needs to be considered that passing synchronous function calls cross partitions, may have an impact on the scheduling behavior of the software. Therefore, it is preferable to do this in the [Host Software Cluster](#), or - even better - to avoid this by implementing the master satellite pattern in the related BSW modules.

As a consequence:

Inside a partition, such direct function calls to the BSW module in the [Host Software Cluster](#) are easily possible, with little overhead. If a BSW service is needed in a specific partition (including safety partition), the [Host Software Cluster](#) should offer the service interface in this partition. If this is not possible, the according transition shall be implemented in the [Host Software Cluster](#). To support this, the [Proxy Modules](#) have to grant a partition write access to their interfaces.

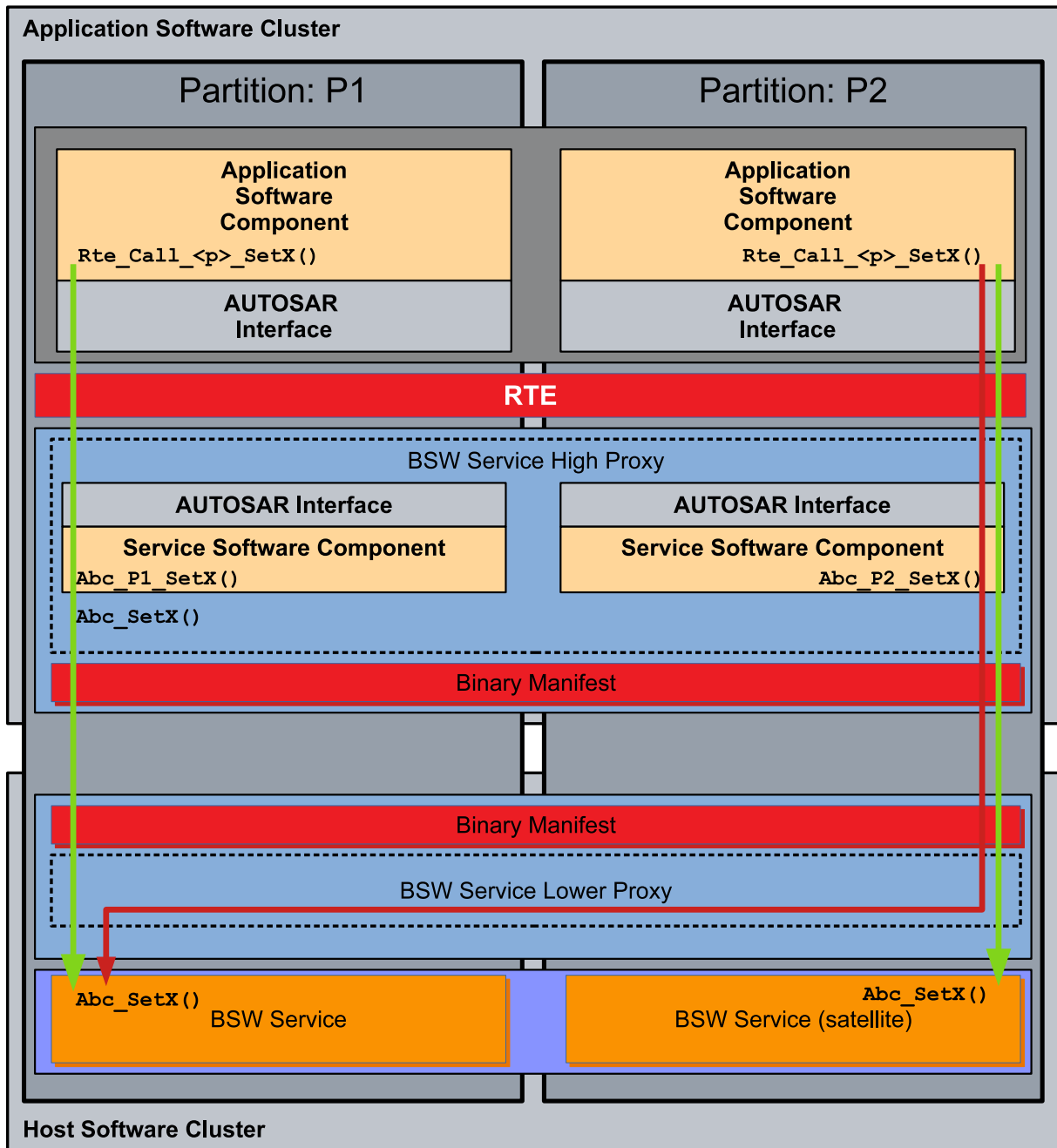

Figure 7.10: Proxy Modules and Partitions

Figure 7.10 illustrates this approach. The AUTOSAR Interfaces are offered in each partition, via a dedicated Service Software Component. The related Standardized AUTOSAR Interface is provided in exactly one Partition, in which the BSW module integration is supported.

A call from the Application Software Component is passed vertically through the partition, down to the BSW Module or its satellite (green arrow).

If such a satellite is not available, the Low Proxy Module can implement (e.g. via SchM) a cross partition call (red arrow).

[SWS_SwCluC_02001]{DRAFT} [The High Proxy shall provide the applicable Standardized AUTOSAR Interfaces once per configured `EcucPartition`. In doing so, the APIs are provided with the original `Mip`, at the `EcucPartition` where the `SwCluCNativeBswApi` is set to `true`. For all the other BSW API instances, the `Mip` is replaced by `<Mip>_<shortName of EcucPartition>`.]()

[SWS_SwCluC_02002]{DRAFT} [The High Proxy shall create one partition specific Service Software Component per configured `EcucPartition`, with the name `<Mip>_<EcucPartition shortName>`.]()

[SWS_SwCluC_02003]{DRAFT} [The High Proxy shall provide the Ports belonging to a specific `CpSoftwareClusterServiceResource`, at the partition specific Service Software Component, to which the using `SwComponentPrototype` is mapped to.]()

7.4.2.3 Unconnected Service Resources

[SWS_SwCluC_02004]{DRAFT} [The High Proxy shall implement a 'reasonable' behavior for a service resource, if the connection to the resource provider does not exist. In any case, the OUT arguments of functions shall return a 'neutral' value, or the value which can be assumed after a reset. The functional behavior should be like the state directly after a reset, before further activity occurred.]()

Note: To decide what is 'reasonable', a functional understanding of the service resource is required. Therefore, **[SWS_SwCluC_02004]** can only give some rough expectations.

7.4.2.4 Ecu Configuration Principles

[SWS_SwCluC_02005]{DRAFT} [To resolve the ECU Configuration dependency, the Proxy Module implementation shall define a Vendor Specific Module Definition [18], where the ECU Configuration container and parameters are used to configure the interface towards the user of the substituted BSW Module.]()

Typically, those are the containers and parameters configuring the variation (e.g. existence) of Standardized AUTOSAR Interfaces, or parameters relevant for symbolic name values.

In addition, these containers need to have a relationship to the software cluster resource pool, in order to manage the configuration needs exchange between the different `Software Cluster` providers. Furthermore, the `CpSoftwareClusterServiceResource` element defines the `globalResourceId`, which is required for the resource entries in the `Binary Manifest`.

[SWS_SwCluC_02006]{DRAFT} [The Proxy Module implementation shall define an `EcucContainerDef`, which defines a mapping between

- the `EcucContainerDef`(s) identifying the module user channel in the `StMD` of substituted BSW Module

AND

- the `CpSoftwareClusterServiceResource` representing the user channel in the software cluster resource pool. The `EcucForeignReferenceDef` shall be named `SwCluCResourceRef`.

]()

Note that this `EcucContainerDef` of [SWS_SwCluC_02006] can also be used to add additional Parameters, to control the connection behavior between `High Proxy` and `Low Proxy`. For an example, see: `SwCluCnvMPProxyNvBlock`.

[SWS_SwCluC_02007]{DRAFT} [The Proxy Module implementation shall define, for each different Proxy Module, an `EcucEnumerationParamDef` named `SwCluCProxyGeneration<Mip>`, with the literals

- `PROXY_DISABLED`, to disable the according Proxy Module code and AUTOSAR model generation
- `HIGH_PROXY`, to enable the according High Proxy Module code and AUTOSAR model generation
- `LOW_PROXY`, to enable the according Low Proxy Module code and AUTOSAR model generation

](`SRS_SwCluC_00204`)

7.4.2.5 Proxy Modules and Binary Manifest

It is the responsibility of the `Proxy Module` implementation to put its `Resource Entries` into the `Binary Manifest` of the respective `Software Cluster`. This includes service user specific channels (e.g. for a specific NV block), or some general links - typically named base socket - to link some generic infrastructure between `Low` and `High Proxy` (e.g. the set of BSW APIs).

[SWS_SwCluC_02008]{DRAFT} [The `Proxy Module` implementation of the `Software Cluster Connection` shall put one `Resource Entry`, for each associated `CpSoftwareClusterServiceResource`, into the `Binary Manifest`.]()

7.4.3 Specific Proxy Module Requirements

7.4.3.1 OS Proxy

7.4.3.1.1 Enable OS Proxy Generation

[SWS_SwCluC_02200]{DRAFT} [The OS High Proxy code, and related AUTOSAR model descriptions, shall only be created, if the configuration parameter *SwCluCProxyGenerationOs* is set to HIGH_PROXY.] (*SRS_SwCluC_00204*)

[SWS_SwCluC_02201]{DRAFT} [The OS LOW Proxy code, and related AUTOSAR model descriptions, shall only be created, if the configuration parameter *SwCluCProxyGenerationOs* is set to LOW_PROXY.] (*SRS_SwCluC_00204*)

7.4.3.1.2 General OS Proxy functionality

7.4.3.1.3 Overview

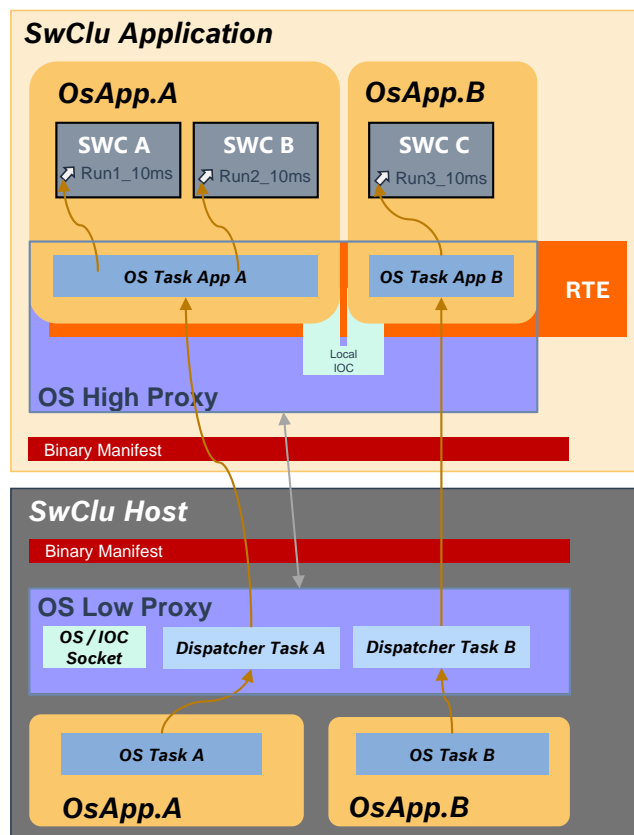

Figure 7.11: Overview of Os Proxy

As explained in chapter 7.1.1 and 7.4.1, the concept of [Software Clusters](#) also has to provide a way to divide some parts of an AUTOSAR [Os](#) into smaller units (see document [5] as reference for [Os](#)). Basically, [runnables](#) of a [Software Cluster](#) shall be executed on a target [machine](#). Since the system is divided into a machine dependent part ([Host Software Cluster](#)), and several [machine](#) independent parts ([Application Software Clusters](#)), an interface layer in between is required. This layer will be realized using the proxy concept.

The [Application Software Cluster](#) contains proxies for those parts of the OS implementation that are needed to complete the runtime environment (RTE). This is called [Os High Proxy](#).

The [Host Software Cluster](#) will implement the AUTOSAR [Os](#), as well as the overall configuration of the [machine](#). The [Os Low Proxy](#) makes this AUTOSAR [Os](#) accessible by the [Os High Proxy](#), via the [Binary Manifest](#). Both are linked together via the information held in the [Binary Manifest](#), which enables an API exchange between [Software Clusters](#).

The OS features (e.g. tasks, resources, spinlocks) supported by the [Os High Proxy](#) are configured with [EcucModuleConfigurationValues](#) for an [Os EcucModuleDef](#), with according [OsTask](#), [OsResource](#), [OsSpinlock](#), etc. containers. In the [Application Software Cluster](#) and in the [Host Software Cluster](#), the configuration of [SwCluCOsProxyOsTask](#), [SwCluCOsProxyOsResource](#), [SwCluCOsProxyOsSpinlock](#), etc. containers map the OS configuration containers to [CpSoftwareClusterServiceResources](#), defining each the [globalResourceId](#) and the [isMandatory](#) attribute, relevant for the corresponding [Resource Entry](#) in the [Binary Manifest](#).

The [Os Low Proxy](#) provides an [Os](#)- and [IOC](#)-socket for each [Application Software Cluster](#). It also provides a dispatcher, which is responsible for calling each [Os-Task](#) of an [Application Software Cluster](#). The [Os](#)- and [IOC](#)-socket provides basic hooks to the [Application Software Cluster](#). These are used, for example, to do basic initialization of local [Os](#) and [IOC](#) channels, to forward general APIs like [spinlock](#), or to do a context switch. The dispatcher controls and calls the [Os-Tasks](#) from the [Application Software Cluster](#). This could, for example, be implemented as [runnables](#), which are indirectly calling the [Os High Proxy Task](#), depending on the entry found in the [Binary Manifest](#).

The [Host Software Cluster](#) provides the implementation of [Os Applications](#), and an abstraction of them in the [Os Low Proxy](#). The [Os-Application](#) context inside an [Application Software Cluster](#) matches to the corresponding [Os Application](#) in the [Host Software Cluster](#). The [Os High Proxy](#) task is executed in the same context as the low proxy task, and has the same level of priority, trust and access.

As mentioned before, a connection between [Os Low Proxy](#) and [Os High Proxy](#) is required. It will be established with the mechanism described in chapter 7.1.5.2 ([Connecting Resources](#)). In this chapter, the metaclasses for [Os service resources](#)

are defined: `CpSoftwareClusterServiceResources`. Essential to run a `Application Software Cluster` are resources for the Os- and IOC-socket and the Os-ProxyTasks. These resources are part of the system's resource pool (`CpSoftwareClusterResourcePool`), which includes the description of their relevant attributes and a unique ResourceID (`CpSoftwareClusterResource.globalResourceId`). A valid connection can only be established, if all attributes configured for those resources match during the connection process.

To achieve a robust system, and to avoid erroneous behavior, it is recommended to mark Os service resources as mandatory.

Detailed requirements can be found below.

7.4.3.1.4 General requirements

[SWS_SwCluC_02202]{DRAFT} [The Os Proxy shall support the execution of Os-Tasks from an `Application Software Cluster`, in the context of the `Host Software Cluster`.]()

[SWS_SwCluC_CONSTR_02203]{DRAFT} Constraint for Interrupts [Interrupts are not supported for an `Application Software Cluster`, since it does not have access to the hardware or peripherals.]()

[SWS_SwCluC_02204]{DRAFT} [The Os Proxy shall support a socket mechanism to hook several `Application Software Clusters` onto the `Host Software Cluster`.]()

For example, this can be used to support `Application Software Cluster` local IOC communication paths.

[SWS_SwCluC_02205]{DRAFT} [The Os High Proxy interfaces shall be described with the parameters, and according containers, as defined in Os `EcucModuleDef`.]()

[SWS_SwCluC_02206]{DRAFT} [The Os Proxy interfaces shall be configured as a service resource, with the parameters as defined in the `SwCluCOsProxy` container.]()

7.4.3.1.5 OS High Proxy

[SWS_SwCluC_02210]{DRAFT} [The Os High Proxy shall provide the header file `Os.h` and `Os_Cfg.h`.]()

[SWS_SwCluC_02211]{DRAFT} [The Os High Proxy shall provide a proxy Os-Task, to which events from the `Application Software Cluster` can be mapped, during the design of an `Application Software Cluster`.]()

[SWS_SwCluC_02230]{DRAFT} [The Os High Proxy shall support the implementation of a task body of the proxy OsTask, with the `TASK()` macro.]()

[SWS_SwCluC_02212]{DRAFT} [The `Os High Proxy` shall provide a set of OS APIs that are required by the `Application Software Cluster`:

- `ActivateTask`
- `ChainTask`
- `TerminateTask`
- `Schedule`

](`SRS_SwCluC_00202`)

[SWS_SwCluC_02213]{DRAFT} [If `SwCluCOsProxyOsTask.SwCluCOsProxy-TaskActivation.PASS_TASK_ACTIVATION` is set for a specific `OsTask`, the API `ActivateTask` called for this OS task shall trigger a task activation in the `Host Software Cluster`.]()

[SWS_SwCluC_02229]{DRAFT} [If `SwCluCOsProxyOsTask.SwCluCOsProxy-TaskActivation.OMIT_TASK_ACTIVATION` is set for a specific `OsTask`, the API `ActivateTask` called for this OS task returns without effect.]()

[SWS_SwCluC_02214]{DRAFT} [In an `Application Software Cluster`, the `Os High Proxy` shall provide a '`ChainTask`' API which is implemented as macro and must contain a return statement.]()

Please note: The OS task chaining can only be handled in the OS implementation in the `Host Software Cluster`.

[SWS_SwCluC_CONSTR_02282]{DRAFT} **Constraint for `ChainTask`** [In an `Application Software Cluster`, the '`ChainTask`' API shall only be called at the end of the function body of an '`OS Task`'.]()

[SWS_SwCluC_02215]{DRAFT} [In an `Application Software Cluster`, the `Os High Proxy` shall provide a '`TerminateTask`' API which is implemented as a macro and must contain a return statement.]()

Please note: The real OS task termination can only be handled in the OS implementation in the `Host Software Cluster`.

[SWS_SwCluC_CONSTR_02283]{DRAFT} **Constraint for `TerminateTask`** [In an `Application Software Cluster`, the '`TerminateTask`' API shall only be called at the end of the function body of an '`OS Task`'.]()

Rationale:

When developing an `Application Software Cluster`, the `Os High Proxy` has no ability to call to the 'real' OS to activate or terminate tasks based on calls to '`ChainTask`', '`ActivateTask`' or '`TerminateTask`'. However, this does not mean that calls to these functions cannot exist within application cluster code. It simply means that a `SwCluC` module implementation must contain 'stub' representations of these functions in an `Os High Proxy` which have no effect when called within an application cluster

which has not been integrated in the final system which includes a [Host Software Cluster](#).

However, given that application clusters will eventually be integrated together with a host cluster, code in an application cluster must follow some rules to ensure that their usage of task management APIs do not clash with the intended use case of cyclic execution in cluster based configurations.

Note: Where constraints [\[SWS_SwCluC_CONSTR_02282\]](#) and [\[SWS_SwCluC_CONSTR_02283\]](#) restrict the usage of [ChainTask](#) and [TerminateTask](#) in an [Application Software Cluster](#), no such constraint exists to restrict the usage of 'ActivateTask'.

In a clustered software architecture, the dynamic behavior of the ECU is controlled by the [Host Software Cluster](#). Hence, the [Host Software Cluster](#) is in charge to control the activation of [OS Tasks](#).

Nevertheless, use cases may exist to sporadically activate [OS Tasks](#) on demand of an [Application Software Cluster](#). For this reason, the [ActivateTask](#) API is offered by the [Os High Proxy](#) which is fully functional in case of [\[SWS_SwCluC_02213\]](#). In opposite to 'TerminateTask' and 'ChainTask' the 'ActivateTask' API usage is not bound to the task body. The usage of 'ActivateTask' APIs in [Application Software Cluster](#) needs to be carefully aligned with the overall dynamic scheduling concept of the ECU!

[SWS_SwCluC_02216]{DRAFT} [The [Os High Proxy](#) shall provide default handles for resources, in case a connection to the host system could not be established successfully between [Application Software Cluster](#) and the [Host Software Cluster](#). The default implementation shall be a neutral behavior, with the return value `E_OK`, to support "standard status" from OS.]()

See the section [7.4.3.1.6 'Os Low Proxy'](#), for an explanation of how a missing connection is handled in the [Host Software Cluster](#).

[SWS_SwCluC_02217]{DRAFT} [The [Os High Proxy](#) shall have a service resource [SwCluCOsProxyOsTask](#), for each [OsTask](#) required in the [Application Software Cluster](#). For this resource, an entry in the [Binary Manifest](#) shall be created, to be able to link the task to its [OsLowProxy](#) implementation in the [Host Software Cluster](#). Since the content of the [OsTask](#) is created by the RTE, this API shall be used and registered as service resource. It is recommended that this resource is marked with the mandatory flag ([SwCluCBManifIsMandatory](#)).]()

[SWS_SwCluC_02218]{DRAFT} [The [Os High Proxy](#) shall contain a required service resource [SwCluCOsProxyOsTaskDispatcher](#). The [Proxy-OsTask](#) shall be called in that context. For this resource, an entry in the [Binary Manifest](#) shall be created, to be able to link it to the [OsLowProxy](#) dispatcher in the [Host Software Cluster](#). It is recommended that this resource is marked with the mandatory flag ([SwCluCBManifIsMandatory](#)).]()

[SWS_SwCluC_02219]{DRAFT} [The `Os High Proxy` shall contain a required service resource `SwCluCOsProxyFunctionDispatcher`. This function dispatcher is used to call functions in context of the `Host Software Cluster`. For this resource, an entry in the `Binary Manifest` shall be created, to be able to link it to the `OsLow-Proxy` dispatcher in the `Host Software Cluster`.]()

For example, to call an `Application Software Cluster` local `Bsw-Module Init` function, in dedicated context of the `Host Software Cluster`.

[SWS_SwCluC_02220]{DRAFT} [The `Os High Proxy` shall contain a required service resource `SwCluCOsProxyOsBaseSocket`. This collects all hooks needed to be linked to the `Host Software Cluster`. It also contains `Application Software Cluster` local `Os` specific functions for `StartOs`, `initialize` and `shutdown`. It should also cover the local `IOC`, if present. It is recommended that this resource is marked with the mandatory flag (`SwCluCBManifIsMandatory`).]()

Please note: This is highly vendor specific.

[SWS_SwCluC_02221]{DRAFT} [Since a `Application Software Cluster` can contain several `OS Applications`, the `Os High Proxy` shall be able to provide a local `IOC` implementation for the cluster internal communication paths between `OS Applications`. The link to the `Host Software Cluster` shall be established as part of the `SwCluCOsProxyOsBaseSocket` service resource.]()

[SWS_SwCluC_02222]{DRAFT} [The `Os High Proxy` shall require a service resource `SwCluCOsProxyOsApplication`, which is used in the `Application Software Cluster`, and needs to be matched to the `Host Software Cluster`.]()

This service resource represents the actual configuration of the `Application Software Cluster`'s local `OS Application`, with its parameters and linked local `OS` objects.

[SWS_SwCluC_02223]{DRAFT} [The `Os High Proxy` shall require a service resource `SwCluCOsProxyOsResource`, which is used in the `Application Software Cluster`, and needs to be matched to the `Host Software Cluster`.]()

[SWS_SwCluC_02224]{DRAFT} [The `Os High Proxy` shall require a service resource `SwCluCOsProxyOsSpinlock`, which is used in the `Application Software Cluster`, and needs to be matched to the `Host Software Cluster`.]()

[SWS_SwCluC_02225]{DRAFT} [The `Os High Proxy` shall provide the following APIs for the `Application Software Cluster`:

- `GetResource`
- `ReleaseResource`
- `SuspendOSInterrupts`
- `ResumeOSInterrupts`
- `GetSpinlock`

- `ReleaseSpinlock`
- `GetApplicationID`
- `GetCoreID`
- `CallTrustedFunction`

Each of these APIs corresponds to a service resource in the `Os Low Proxy`. There will be an entry in the `Binary Manifest`, to require these service resources, which are described here: `SwCluCOsProxy`.] (`SRS_SwCluC_00202`)

[SWS_SwCluC_02279] [If the configuration parameter `SwCluCOsProxyIdTranslationEnabled` is enabled, the `Os High Proxy` shall support the translation of IDs (`CoreId`, `OsApplicationId`) configured in the `Host Software Cluster` into `Application Software Cluster` specific local IDs.] ()

Rationale: This is to avoid larger look-up tables required to fetch the correct ID configured in the `Host Software Cluster` for the use case where only a subset of the `Host Software Cluster` OS configuration is provided to the `Application Software Clusters`.

[SWS_SwCluC_02280] [If the configuration parameter `SwCluCOsProxyIdTranslationEnabled` is enabled, the ID reported by the following OS APIs for the `Application Software Clusters`:

- `GetApplicationID`
- `GetCoreID`

shall correspond to the `Application Software Cluster` specific local IDs. (See `[SWS_SwCluC_02279]`)] ()

[SWS_SwCluC_CONSTR_02281]{DRAFT} **Consistent ID configuration between Host Software Clusters and Application Software Clusters** [In case the parameter `SwCluCOsProxyIdTranslationEnabled` is set to `false` the configuration of core ID and application ID values in the according `Application Software Cluster` shall be identically to the ID values configured in the `Host Software Cluster`.] ()

[SWS_SwCluC_02226]{DRAFT} [The `Os High Proxy` shall NOT support the following APIs for the `Application Software Cluster`.

- `StartScheduleTable`
- `StopScheduleTable`
- `DisableAllInterrupts`
- `EnableAllInterrupts`
- `SuspendAllInterrupts`
- `ResumeAllInterrupts`

]()

[SWS_SwCluC_02227]{DRAFT} [The configuration of the [Os High Proxy](#) for a complete [Application Software Cluster](#) shall be specified with a set of ECUC-parameters defined here: [SwCluCOsProxy](#).]()

7.4.3.1.6 OS Low Proxy

[SWS_SwCluC_02250]{DRAFT} [The [Os Low Proxy](#) shall only be provided by the [Host Software Cluster](#).]()

[SWS_SwCluC_02251]{DRAFT} [The configuration of the [Os Low Proxy](#) for a complete [Host Software Cluster](#) shall be specified with a set of ECUC-parameters defined here: [SwCluCOsProxy](#). The configuration of the [Os Low Proxy](#) shall be derived from the implemented configuration for the Os in the [Host Software Cluster](#).]()

[SWS_SwCluC_02252]{DRAFT} [The [Os Low Proxy](#) shall provide a socket for the [Os High Proxys](#) of the [Application Software Clusters](#). For each [Application Software Cluster](#), a corresponding service resource [SwCluCOsProxyOsBaseSocket](#) and configuration shall be provided.]()

[SWS_SwCluC_02253]{DRAFT} [The [Os Low Proxy](#) shall provide for each [SwCluCOsProxyOsBaseSocket](#) a [SwCluC_OsProxy_Init](#) API, to initialize the [Os High Proxy](#) of an [Application Software Cluster](#). This shall be one element of the service resource [SwCluCOsProxyOsBaseSocket](#).]()

For example, an Init-Callback could be provided for each [Application Software Cluster](#), and called from the [Os Low Proxy](#) during initialization phase of the [Host Software Cluster](#).

[SWS_SwCluC_02254]{DRAFT} [The [Os Low Proxy](#) shall provide an API to start the [Os High Proxy](#) of an [Application Software Cluster](#). This shall be one element of the service resource [SwCluCOsProxyOsBaseSocket](#).]()

For example, a Startup hook could be provided for each [Application Software Cluster](#).

[SWS_SwCluC_02255]{DRAFT} [The [Os Low Proxy](#) shall provide an API to shut-down the [Os High Proxy](#) of an [Application Software Cluster](#). This shall be one element of the service resource [SwCluCOsProxyOsBaseSocket](#).]()

For example, a shutdown hook could be provided for each [Application Software Cluster](#).

[SWS_SwCluC_02256]{DRAFT} [The [Os Low Proxy](#) shall be able to provide an API to connect IOC from [Os High Proxy](#) of an [Application Software Cluster](#). This shall be one element of the service resource [SwCluCOsProxyOsBaseSocket](#).]()

For example, an IOC-Init callback could be provided for each [Application Software Cluster](#), and called from the [Os Low Proxy](#), if a connection is established.

Dispatchers

[SWS_SwCluC_02270] [The [Os Low Proxy](#) shall have a service resource [SwCluCOSProxyOsTaskDispatcher](#), for each task dispatcher provided in the [Host Software Cluster](#). For this resource, an entry in the [Binary Manifest](#) shall be created, to be able to link the task dispatcher to its [Os High Proxy](#) implementation in the [Application Software Cluster](#).]()

Please note section 'Overview of Os Proxy' [7.11](#).

Example: The [Host Software Cluster](#) has a full configuration of the [Os](#), and is prepared to host several [Application Software Cluster](#), with their local RTE, to be able to execute the runnables of the [Application Software Clusters](#) [Software](#) components. This preconfiguration will preserve positions in an [OsTask](#), like for events of runnables. Instead of executing a runnable, a so called dispatcher will be executed. This dispatcher acts as a link to [Application Software Clusters](#) task container, which will then execute all mapped runnables for this specific part of the task.

A connection between [Software Clusters](#) is established, when [ResourceIDs](#) in the [Binary Manifests](#) matches. This is necessary for service resources of the task dispatcher and the task itself. It is advised to check the connection status of these, in the implementation of the task dispatcher.

[SWS_SwCluC_02259]{DRAFT} [The [Os Low Proxy](#) shall provide a service resource [SwCluCOSProxyOsTask](#), for each [Application Software Clusters](#) task configuration that the system shall be prepared for. For this resource, an entry in the [Binary Manifest](#) shall be created, to be able to link it to the [Os High Proxy](#) task in the [Host Software Cluster](#).]()

Please note that the [SwCluCOSProxyOsTask](#) container has a reference to a [OsTask](#) container. This reference shall be used in the [Host Software Cluster](#) and the [Application Software Cluster](#) to obtain the [OsTask](#) configuration relevant for the guard value calculation. Hence, it is ensured that [Host Software Cluster](#) and [Application Software Cluster](#)'s [OsTask](#) configuration is compatible. See as well [\[SWS_SwCluC_90004\]](#).

[SWS_SwCluC_02271] [The [Os Low Proxy](#) shall have a service resource [SwCluCOSProxyFunctionDispatcher](#), for each function dispatcher provided in the [Host Software Cluster](#). For this resource, an entry in the [Binary Manifest](#) shall be created, to be able to link the function dispatcher to its [Os High Proxy](#) implementation in the [Application Software Cluster](#).]()

Example: The [Host Software Cluster](#) has a full configuration of the BSW. To initialize all modules properly, a call to [Application Software Cluster](#) might be necessary. For example, to initialize a local RAM area there. Since this function or runnable might not be known by the RTE as runnable of a [Software Component](#),

this function can be called via the Os proxy function dispatcher. This dispatcher can be configured in the `Host Software Cluster`, to be called from ECUM or an Ini-Task. Each dispatcher provides its own service resource in the `Binary Manifest`. If a successful link to another `Software Cluster` is established, the call can be executed from the `Host Software Cluster` into the `Application Software Cluster`.

Scheduling of dispatchers in Host Software Cluster

[SWS_SwCluC_02272] [The `Os Low Proxy` shall create one partition specific `Service Software Component` per configured `EcucPartition` for the dispatcher, with the name `SwCluC_Dispatcher_<EcucPartition shortName>`.]()

[SWS_SwCluC_02273] [The `Os Low Proxy` shall create one `RunnableEntity` per configured `SwCluCOsProxyOsTaskDispatcher` container in the partition specific `Service Software Component` according [SWS_SwCluC_02272].

The `EcucPartition` is determined by the parameter `SwCluCOsProxyEcucPartitionRef`, if configured or alternatively by the `EcucPartition` to which the related `OsTask` belongs. The attributes of the `RunnableEntity` shall be set as following:

- `minimumStartInterval` is set to the parameter value `SwCluCOsProxyMinimumStartInterval`
- `symbol` is set to the name of the task dispatcher's C-function used for implementation of [SWS_SwCluC_02270]
- `canBeInvokedConcurrently` is set to `false`

]()

[SWS_SwCluC_02278] [The `Os Low Proxy` shall create one `InitEvent` per configured `SwCluCOsProxyDispatcherInitEvent` container in the partition specific `Service Software Component` according [SWS_SwCluC_02272]. The attributes of the `InitEvent` shall be set as following:

- `shortName` is set according the container's `shortName`
- `startOnEvent` is set to the `RunnableEntity` according [SWS_SwCluC_02273] related to the owning `SwCluCOsProxyOsTaskDispatcher` container.

]()

[SWS_SwCluC_02274] [The `Os Low Proxy` shall create one `BackgroundEvent` per configured `SwCluCOsProxyDispatcherBackgroundEvent` container in the partition specific `Service Software Component` according [SWS_SwCluC_02272]. The attributes of the `BackgroundEvent` shall be set as following:

- `shortName` is set according the container's `shortName`

- `startOnEvent` is set to the `RunnableEntity` according [SWS_SwCluC_02273] related to the owning `SwCluCOsProxyOsTaskDispatcher` container.
- `disabledMode(s)` are created according the `SwCluCOsProxyDisabledModeInstanceRef(s)` where for each different `PPortPrototype` an `RPortPrototype` is created at the owing Service Software Component according [SWS_SwCluC_02272] and used as `contextPort`.

]()

[SWS_SwCluC_02275] [The `Os Low Proxy` shall create one `TimingEvent` per configured `SwCluCOsProxyDispatcherTimingEvent` container in the partition specific Service Software Component according [SWS_SwCluC_02272]. The attributes of the `TimingEvent` shall be set as following:

- `shortName` is set according the container's `shortName`
- `startOnEvent` is set to the `RunnableEntity` according [SWS_SwCluC_02273] related to the owning `SwCluCOsProxyOsTaskDispatcher` container
- `period` value is set according the `SwCluCOsProxyTimingEventPeriod` parameter
- `disabledMode(s)` are created according the `SwCluCOsProxyDisabledModeInstanceRef(s)` where for each different `PPortPrototype` an `RPortPrototype` is created at the owing Service Software Component according [SWS_SwCluC_02272] and used as `contextPort`.

]()

[SWS_SwCluC_02276] [The `Os Low Proxy` shall create one `SwcModeSwitchEvent` per configured `SwCluCOsProxyDispatcherModeSwitchEvent` container in the partition specific Service Software Component according [SWS_SwCluC_02272]. The attributes of the `SwcModeSwitchEvent` shall be set as following:

- `shortName` is set according the container's `shortName`
- `startOnEvent` is set to the `RunnableEntity` according [SWS_SwCluC_02273] related to the owning `SwCluCOsProxyOsTaskDispatcher` container
- `activation` value is set according the `SwCluCOsProxyDispatcherActivation` parameter
- `modes` are created according the `SwCluCOsProxyModeInstanceRef(s)` where for each different `PPortPrototype` an `RPortPrototype` is created at the owing Service Software Component according [SWS_SwCluC_02272] and used as `contextPort`.

- `disabledMode(s)` are created according the `SwCluCOsProxyDisabledModeInstanceRef(s)` where for each different `PPortPrototype` an `RPortPrototype` is created at the owing Service Software Component according [SWS_SwCluC_02272] and used as `contextPort`.

]()

[SWS_SwCluC_02277] [The `Os Low Proxy` shall create one `ExternalTriggerOccurredEvent` per configured `SwCluCOsProxyDispatcherExternalTriggerOccurredEvent` container in the partition specific Service Software Component according [SWS_SwCluC_02272]. The attributes of the `ExternalTriggerOccurredEvent` shall be set as following:

- `shortName` is set according the container's `shortName`
- `startOnEvent` is set to the `RunnableEntity` according [SWS_SwCluC_02273] related to the owing `SwCluCOsProxyOsTaskDispatcher` container
- `trigger` is set according the `SwCluCOsProxyTriggerInstanceRef` where for each different `PPortPrototype` an `RPortPrototype` is created at the owing Service Software Component according [SWS_SwCluC_02272] and used as `contextRPort`.
- `disabledMode(s)` are created according the `SwCluCOsProxyDisabledModeInstanceRef(s)` where for each different `PPortPrototype` an `RPortPrototype` is created at the owing Service Software Component according [SWS_SwCluC_02272] and used as `contextPort`.

]()

OsApplication

[SWS_SwCluC_02262]{DRAFT} [The `Os Low Proxy` shall provide a service resource `SwCluCOsProxyOsApplication`, for each `OsApplication` that is configured in the `Host Software Cluster`, and prepared for use in `Application Software Clusters`.]()

OsResource

[SWS_SwCluC_02263]{DRAFT} [The `Os Low Proxy` shall provide a service resource `SwCluCOsProxyOsResource`, for each `OsResource` used in `Application Software Clusters`.]()

OsSpinlock

[SWS_SwCluC_02264]{DRAFT} [The `Os Low Proxy` shall provide a service resource `SwCluCOsProxyOsSpinlock`, for each `OsSpinlock` used in `Application Software Clusters`.]()

OS APIs

[SWS_SwCluC_02265]{DRAFT} [The [Os Low Proxy](#) shall provide a basic service implementation for the following APIs, to be used and connected with an [Application Software Cluster](#):

- [GetResource](#)
- [ReleaseResource](#)
- [SuspendOSInterrupts](#)
- [ResumeOSInterrupts](#)
- [ReleaseResource](#)
- [GetSpinlock](#)
- [ReleaseSpinlock](#)
- [GetApplicationID](#)
- [Schedule](#)
- [CallTrustedFunction](#)
- [GetCoreID](#)

These APIs shall be provided with a corresponding service resource from [SwCluC-
COsProxy.\]\(\)](#)

Unconnected Service Resources

[SWS_SwCluC_02266]{DRAFT} [The [Os Low Proxy](#) shall provide default handles for resources, in case a connection could not be established successfully between [Application Software Cluster](#) and the [Host Software Cluster](#).]()

For example, if an [Application Software Cluster](#) is missing, the task-dispatcher in the host calls an empty function.

Please note: One property of a clustered system is that parts shall be independently buildable. Another property is that some parts can be absent. Therefore, "default stubs" are needed for non-local APIs. But in case of missing interfaces to [Os, Application Software Clusters](#) cannot run successfully. The usage of a suitable mechanism to detect this case is advised. To achieve a robust system, the [Host Software Cluster](#) is still running in such a state.

7.4.3.2 NvM Proxy

The specified NvM Proxy has the following underlying design principle.

In the [Application Software Cluster](#), NV Blocks supported by the NvM High Proxy are configured with [EcucModuleConfigurationValues](#) for a NvM [EcucModuleDef](#), with according [NvMBlockDescriptors](#) containers. In the [Application Software Cluster](#) and in the [Host Software Cluster](#), the configuration of [SwCluCnvMProxyNvBlock](#) containers map the [NvMBlockDescriptors](#) to [CpSoftwareClusterServiceResources](#), defining each the [globalResourceId](#) and the [isMandatory](#) attribute, relevant for the corresponding [Resource Entry](#) in the [Binary Manifest](#).

The connection between the [NvM High Proxy](#) and the [NvM Low Proxy](#) utilizes the explicit synchronization, as specified in document [6]. The explicit synchronization has the advantage that the addresses of RAM Blocks and ROM blocks of [Application Software Cluster](#) do not have to be known by the NVRAM Manager in the [Host Software Cluster](#). In addition, the function interface can be used to introduce additional functionality, like the NV block length adjustment ([\[SWS_SwCluC_02105\]](#)). On the other hand, this design principle cannot support temporary RAM blocks, since the NvM configuration in the [Host Software Cluster](#) may hold a different size than the NvM configuration in the [Application Software Cluster](#).

[SWS_SwCluC_CONSTR_02134]{DRAFT} [The NvM High Proxy shall reject configurations of temporary RAM blocks.]([SRS_SwCluC_00206](#))

Note: this means only NVRAM blocks configured with a permanent RAM block or explicit synchronization callbacks are supported in the NvM High Proxy.

In addition, the [Host Software Cluster](#) should not have a functional dependency to the content stored in NV Blocks of the [Application Software Cluster](#). Furthermore, the NvM High Proxy shall be able to initialize the RAM Block, even if the related NV Block is not connected to a [Host Software Cluster](#). This requires the existence of ROM block default values.

[SWS_SwCluC_CONSTR_02135]{DRAFT} [The NvM High Proxy shall reject configurations, where no ROM block is configured via the parameter [NvMRomBlockDataAddress](#), or the parameter [NvMBlockDescriptor.NvMInitBlockCallback](#).]([SRS_SwCluC_00206](#))

[SWS_SwCluC_CONSTR_02141]{DRAFT} [The NvM High Proxy shall reject configurations, where the NV Block length given by [NvMNvBlockLength](#) is larger than the maximum size foreseen in the [Host Software Cluster](#), given by [SwCluCnvMProxyNvBlockMaxLength](#).]([SRS_SwCluC_00206](#))

Please note that [SwCluCnvMProxyNvBlockMaxLength](#) is also part of the guard value, and therefore protected from unilateral changes.

7.4.3.2.1 Enable NvM Proxy Generation

[SWS_SwCluC_02101]{DRAFT} [The NvM High Proxy code, and related AUTOSAR model descriptions, shall only be created, if the configuration parameter `SwCluCProxyGenerationNvM` is set to `HIGH_PROXY`.] ([SRS_SwCluC_00206](#), [SRS_SwCluC_00204](#))

[SWS_SwCluC_02144]{DRAFT} [The NvM Low Proxy code, and related AUTOSAR model descriptions, shall only be created, if the configuration parameter `SwCluCProxyGenerationNvM` is set to `LOW_PROXY`.] ([SRS_SwCluC_00206](#), [SRS_SwCluC_00204](#))

7.4.3.2.2 General NvM Proxy functionality

[SWS_SwCluC_02104]{DRAFT} [The NvM Proxy shall support that the BlockIds of the NvM of `Host Software Cluster` can change, without reconfiguration or rebuild of the `Application Software Cluster` using these NV blocks.] ([SRS_SwCluC_00206](#))

[SWS_SwCluC_02105]{DRAFT} [The NvM Proxy shall support that the NV block length used in the `Application Software Cluster` can be \leq the NV block length configured in the NvM of the `Host Software Cluster`. In case NV block length in `Application Software Cluster` is smaller, the NV block is filled with default values. The default fill value of a single byte is defined by the configuration parameter `SwCluCNvMProxyNvBlockFillValue`.] ([SRS_SwCluC_00206](#))

[SWS_SwCluC_02106]{DRAFT} [The NvM Proxy shall support that the NV block length used in the `Application Software Cluster` can be changed (in the range $0 \leq$ NV block length configured in NvM), without reconfiguration or rebuild of the `Host Software Cluster`.] ([SRS_SwCluC_00206](#))

[SWS_SwCluC_02112]{DRAFT} [In case it is configured in the NvM High Proxy, the NvM Proxy shall invoke the `NvM_SingleBlockCallbackFunction` or `JobFinished` operation, when the according instance of the NvM Low Proxy is called.] ([SRS_SwCluC_00206](#))

[SWS_SwCluC_02122]{DRAFT} [In case it is configured in the NvM High Proxy, the NvM Proxy shall invoke the `NvM_InitBlockCallbackFunction` or `InitBlock` operation, when the according instance of the NvM Low Proxy is called.] ([SRS_SwCluC_00206](#))

[SWS_SwCluC_02123]{DRAFT} [In case it is configured in the NvM High Proxy, the NvM Proxy shall invoke the `NvM_ReadRamBlockFromNvm` function or `ReadRamBlockFromNvm` operation, when the according instance of the NvM Low Proxy is called.] ([SRS_SwCluC_00206](#))

[SWS_SwCluC_02124]{DRAFT} [In case it is configured in the NvM High Proxy, the NvM Proxy shall invoke the `NvM_WriteRamBlockToNvm` function or `WriteRamBlockToNvm` operation, when the according instance of the NvM Low Proxy is called.] (*SRS_SwCluC_00206*)

7.4.3.2.3 NvM High Proxy

[SWS_SwCluC_02102]{DRAFT} [The NvM High Proxy shall provide the header file `NvM.h`.] (*SRS_SwCluC_00206*)

[SWS_SwCluC_02103]{DRAFT} [The NvM High Proxy shall provide the symbolic name values for NvBlocks, for NvM users in the `Application Software Cluster`.] (*SRS_SwCluC_00206*)

[SWS_SwCluC_02125]{DRAFT} [The NvM High Proxy shall provide the functions for single block requests

- `NvM_SetDataIndex`
- `NvM_GetDataIndex`
- `NvM_SetBlockProtection`
- `NvM_GetErrorStatus`
- `NvM_SetRamBlockStatus`
- `NvM_SetBlockLockStatus`
- `NvM_CancelJobs`
- `NvM_ReadBlock`
- `NvM_WriteBlock`
- `NvM_RestoreBlockDefaults`
- `NvM_EraseNvBlock`
- `NvM_InvalidateNvBlock`
- `NvM_ReadPRAMBlock`
- `NvM_WritePRAMBlock`
- `NvM_RestorePRAMBlockDefaults`

for NvM users in the `Application Software Cluster`.] (*SRS_SwCluC_00206*, *SRS_SwCluC_00202*)

[SWS_SwCluC_02126]{DRAFT} [The NvM High Proxy shall provide the functions for single block requests, according to **[SWS_SwCluC_02103]**, once per configured `SwCluCnvmBaseSocket`. In doing so, the APIs are provided with the original `MipNvM` at the `EcucPartition`, where the `SwCluCNativeBswApi` is set to `true`. For

all the other `SwCluCnVmBaseSocket` instances, the `Mip NvM` is replaced by `NvM_<shortName of EcucPartition>`.] ([SRS_SwCluC_00206](#))

[SWS_SwCluC_02136]{DRAFT} [The functions

- `NvM_ReadBlock`
- `NvM_WriteBlock`
- `NvM_RestoreBlockDefaults`

of the NvM High Proxy shall only accept single block requests, where the pointer to the RAM data block is set to `NULL_PTR`. Otherwise, `E_NOT_OK` is returned, and the request is discarded.] ([SRS_SwCluC_00206](#))

For example, the function `NvM_GetErrorStatus` can be provided as

```

1  /* EcucPartition "Core0_QM", SwCluCNativeBswApi == true */
2  Std_ReturnType NvM_GetErrorStatus (
3      NvM_BlockIdType BlockId,
4      NvM_RequestResultType * RequestResultPtr
5  )
6  ...
7
8  /* EcucPartition "Core1_QM", SwCluCNativeBswApi == false */
9  Std_ReturnType NvM_Core1_QM_GetErrorStatus (
10     NvM_BlockIdType BlockId,
11     NvM_RequestResultType * RequestResultPtr
12 )
13 ...

```

Note: `SwCluCNativeBswApi` can only be set to `true`, for at most one `SwCluCnVmBaseSocket` container in an `Application Software Cluster` configuration.

Callback Functions

[SWS_SwCluC_02109]{DRAFT} [The NvM High Proxy shall support the optional configuration of a `NvM_SingleBlockCallbackFunction`, according to [[ECUC_NvM_00562](#)], [[ECUC_NvM_00506](#)] and [[ECUC_NvM_00559](#)].] ([SRS_SwCluC_00206](#))

[SWS_SwCluC_02110]{DRAFT} [The NvM High Proxy shall support the optional configuration of a `NvM_PNJF_{Block}` port for `NvMNotifyJobFinished` notification.] ([SRS_SwCluC_00206](#))

[SWS_SwCluC_02115]{DRAFT} [The NvM High Proxy shall support the optional configuration of a `NvM_InitBlockCallbackFunction`, according to [[ECUC_NvM_00561](#)], [[ECUC_NvM_00116](#)] and [[ECUC_NvM_00559](#)].] ([SRS_SwCluC_00206](#))

[SWS_SwCluC_02116]{DRAFT} [The NvM High Proxy shall support the optional configuration of a `NvM_PNIB_{Block}` port for `NvMNotifyInitBlock` notification.] ([SRS_SwCluC_00206](#))

[SWS_SwCluC_02117]{DRAFT} [The NvM High Proxy shall support the optional configuration of a `NvM_ReadRamBlockFromNvm`, according to [[ECUC_NvM_00521](#)].] ([SRS_SwCluC_00206](#))

[SWS_SwCluC_02118]{DRAFT} [The NvM High Proxy shall support the optional configuration of a `NvM_WriteRamBlockToNvm`, according to [ECUC_NvM_00520].] (*SRS_SwCluC_00206*)

[SWS_SwCluC_02119]{DRAFT} [The NvM High Proxy shall support the optional configuration of a `NvM_PM_{Block}` port for `NvMMirror` notification.] (*SRS_SwCluC_00206*)

Multiple Partitions

[SWS_SwCluC_02120]{DRAFT} [The NvM High Proxy shall create one partition specific Service Software Component per configured `EcucPartition`, with the name `NvM_{EcucPartition shortName}`.] (*SRS_SwCluC_00206*)

[SWS_SwCluC_02121]{DRAFT} [The NvM High Proxy shall provide the Ports belonging to a specific Nv Block

- `NvM_PS_{Block}`
- `NvM_PAdmin_{Block}`
- `NvM_PNIB_{Block}`
- `NvM_PNJF_{Block}`
- `NvM_PM_{Block}`

at the partition specific Service Software Component, to which the using `SwComponentPrototype` is mapped.] (*SRS_SwCluC_00206*, *SRS_SwCluC_00201*)

Handling of unconnected blocks

[SWS_SwCluC_02107]{DRAFT} [In case a NV block configured in the NvM High Proxy is not connected to any NvM Low Proxy, the NvM High Proxy shall initialize the Nv RAM Block, with the default values given by `NvMRomBlockDataAddress` and / or `NvMInitBlockCallback`.] (*SRS_SwCluC_00206*)

[SWS_SwCluC_02113]{DRAFT} [In case a NV block configured in the NvM High Proxy is not connected to any NvM Low Proxy, the function `NvM_GetErrorStatus` of the NvM High Proxy shall still return `E_OK`, and the request result is set to `NVM_REQ_RESTORED_FROM_ROM`.] (*SRS_SwCluC_00206*)

[SWS_SwCluC_02114]{DRAFT} [In case a NV block configured in the NvM High Proxy is not connected to any NvM Low Proxy, the functions

- `NvM_SetDataIndex`
- `NvM_GetDataIndex`
- `NvM_SetBlockProtection`
- `NvM_SetRamBlockStatus`
- `NvM_SetBlockLockStatus`

- [NvM_CancelJobs](#)
- [NvM_ReadBlock](#)
- [NvM_WriteBlock](#)
- [NvM_RestoreBlockDefaults](#)
- [NvM_EraseNvBlock](#)
- [NvM_InvalidateNvBlock](#)
- [NvM_ReadPRAMBlock](#)
- [NvM_WritePRAMBlock](#)
- [NvM_RestorePRAMBlockDefaults](#)

of the NvM High Proxy shall return `E_NOT_OK.`] ([SRS_SwCluC_00206](#))

7.4.3.2.4 NvM Low Proxy

As shown in figure 7.10, the NvM Low Proxy shall be able to invoke APIs of the BSW modules in the [Host Software Cluster](#), without a partition change in the [Application Software Clusters](#). This partition change is only needed, if the BSW module does not offer a satellite on this partition. The availability of the BSW modules on dedicated [EcucPartitions](#) is a property of the [Host Software Cluster](#).

[SWS_SwCluC_02132]{DRAFT} [The NvM Low Proxy shall provide the entry functions for single block requests, according to [\[SWS_SwCluC_02103\]](#), once per configured [SwCluCNvMBaseSocket](#) at the [EcucPartition](#) configured by [SwCluCNvMBaseSocket.SwCluCProxyEcucPartitionRef](#).

In case the [SwCluCNvMProxyUsedSatelliteRef](#) is set, the [EcucPartition](#) shall be changed, before the NVM API is called.] ([SRS_SwCluC_00206](#))

[SWS_SwCluC_02111]{DRAFT} [The NvM Low Proxy shall provide an instance of a [NvM_SingleBlockCallbackFunction](#) per configured NV block ([SwCluCNvMProxyNvBlock](#)) in the NvM Low Proxy.] ([SRS_SwCluC_00206](#))

[SWS_SwCluC_02127]{DRAFT} [The NvM Low Proxy shall provide an instance of a [NvM_InitBlockCallbackFunction](#) per configured NV block ([SwCluCNvMProxyNvBlock](#)) in the NvM Low Proxy.] ([SRS_SwCluC_00206](#))

[SWS_SwCluC_02128]{DRAFT} [The NvM Low Proxy shall provide an instance of a [NvM_ReadRamBlockFromNvm](#) per configured NV block ([SwCluCNvMProxyNvBlock](#)) in the NvM Low Proxy.] ([SRS_SwCluC_00206](#))

[SWS_SwCluC_02129]{DRAFT} [The NvM Low Proxy shall provide an instance of a [NvM_WriteRamBlockToNvm](#) per configured NV block ([SwCluCNvMProxyNvBlock](#)) in the NvM Low Proxy.] ([SRS_SwCluC_00206](#))

Contrary to the call of BSW module's APIs from an [Application Software Cluster](#), the invoked callback notifications need to change the partition in the [Host Software Cluster](#), before the calls are ending up in the [Application Software Cluster](#), if the BSW module does not offer a satellite on this partition.

[SWS_SwCluC_02133]{DRAFT} [The callback instances according to [SWS_SwCluC_02111], [SWS_SwCluC_02127], [SWS_SwCluC_02128], and [SWS_SwCluC_02129], are provided

- at the [EcucPartition](#) referenced by [SwCluCnvMProxyNvBlock.SwCluCnvMProxyNvBlockEcucPartitionRef](#), if a [SwCluCnvMBaseSocket](#) is directly available at this [EcucPartition](#)

OR

- at the [EcucPartition](#) of the [SwCluCnvMBaseSocket](#) referenced by the [SwCluCnvMBaseSocket](#) - via [SwCluCnvMProxyUsedSatelliteRef](#), which is on the [EcucPartition](#) given by [SwCluCnvMProxyNvBlock.SwCluCnvMProxyNvBlockEcucPartitionRef](#). In this case, the [EcucPartition](#) shall be changed, before the callback in the [High Proxy](#) is called.

]([SRS_SwCluC_00206](#))

[SWS_SwCluC_02108]{DRAFT} [In case a NV block configured in the [NvM Low Proxy](#) is not connected to any [NvM High Proxy](#), the [NvM Low Proxy](#) implementation shall ensure that the content of the NV block is not modified by the [NvM Low Proxy](#).]([SRS_SwCluC_00206](#))

Note: An access by [Dcm](#) might still change the NV block content in this case.

[SWS_SwCluC_02142]{DRAFT} [The [NvM Low Proxy](#) implementation shall describe the NV blocks provided to [NvM High Proxies](#) via [NvBlockNeeds](#), derived from the [Cp-SoftwareClusterServiceResource.resourceNeeds](#).]([SRS_SwCluC_00206](#))

Note: [SWS_SwCluC_02142] ensures an automated configuration of the [NVRAM Manager](#).

[SWS_SwCluC_02143]{DRAFT} [The [NvM Low Proxy](#) shall provide, for each [SwCluCnvMBaseSocket](#), a [SwCluCnvMProxy_Init](#) API, to initialize the [NvM High Proxy](#) of an [Application Software Cluster](#). This shall be one element of the service resource [SwCluCnvMBaseSocket](#).]()

7.4.3.2.5 Error detection

[SWS_SwCluC_02137]{DRAFT} [If development error detection is enabled for [NvM High Proxy](#), the APIs

- [NvM_SetDataIndex](#)
- [NvM_GetDataIndex](#)

- [NvM_SetBlockProtection](#)
- [NvM_GetErrorStatus](#)
- [NvM_SetRamBlockStatus](#)
- [NvM_SetBlockLockStatus](#)
- [NvM_CancelJobs](#)
- [NvM_ReadBlock](#)
- [NvM_WriteBlock](#)
- [NvM_RestoreBlockDefaults](#)
- [NvM_EraseNvBlock](#)
- [NvM_InvalidateNvBlock](#)
- [NvM_ReadPRAMBlock](#)
- [NvM_WritePRAMBlock](#)
- [NvM_RestorePRAMBlockDefaults](#)

shall report the DET error `NVM_E_UNINIT`, when NVM High Proxy is not yet initialized.]
([SRS_SwCluC_00206](#), [SRS_BSW_00369](#), [SRS_BSW_00323](#), [SRS_BSW_00350](#))

[SWS_SwCluC_02138]{DRAFT} [If development error detection is enabled for NvM High Proxy, the APIs

- [NvM_SetDataIndex](#)
- [NvM_GetDataIndex](#)
- [NvM_SetBlockProtection](#)
- [NvM_GetErrorStatus](#)
- [NvM_SetRamBlockStatus](#)
- [NvM_SetBlockLockStatus](#)
- [NvM_CancelJobs](#)
- [NvM_ReadBlock](#)
- [NvM_WriteBlock](#)
- [NvM_RestoreBlockDefaults](#)
- [NvM_EraseNvBlock](#)
- [NvM_InvalidateNvBlock](#)
- [NvM_ReadPRAMBlock](#)
- [NvM_WritePRAMBlock](#)

- [NvM_RestorePRAMBlockDefaults](#)

shall report the DET error `NVM_E_PARAM_BLOCK_ID`, when the passed `BlockId` is out of range of the `BlockIds` configured in the NvM High Proxy.]([SRS_SwCluC_00206](#), [SRS_BSW_00369](#), [SRS_BSW_00323](#), [SRS_BSW_00350](#))

[SWS_SwCluC_02139]{DRAFT} [If development error detection is enabled for NvM High Proxy, the APIs

- [NvM_ReadBlock](#)
- [NvM_WriteBlock](#)
- [NvM_RestoreBlockDefaults](#)

shall report the DET error `NVM_E_PARAM_ADDRESS`, when a RAM block address different than `NULL_PTR` is passed.]([SRS_SwCluC_00206](#), [SRS_BSW_00369](#), [SRS_BSW_00323](#), [SRS_BSW_00350](#))

7.4.3.3 Com Proxy

7.4.3.3.1 Enable Com Proxy Generation

[SWS_SwCluC_02600]{DRAFT} [The [Com High Proxy](#) code, and related AUTOSAR model descriptions, shall only be created, if the configuration parameter [SwCluCProxyGenerationCom](#) is set to `HIGH_PROXY`.]([SRS_SwCluC_00211](#), [SRS_SwCluC_00204](#))

[SWS_SwCluC_02601]{DRAFT} [The [Com Low Proxy](#) code, and related AUTOSAR model descriptions, shall only be created, if the configuration parameter [SwCluCProxyGenerationCom](#) is set to `LOW_PROXY`.]([SRS_SwCluC_00211](#), [SRS_SwCluC_00204](#))

7.4.3.3.2 General Com Proxy functionality

7.4.3.3.3 Overview

The specified Com Proxy has the following underlying design principle.

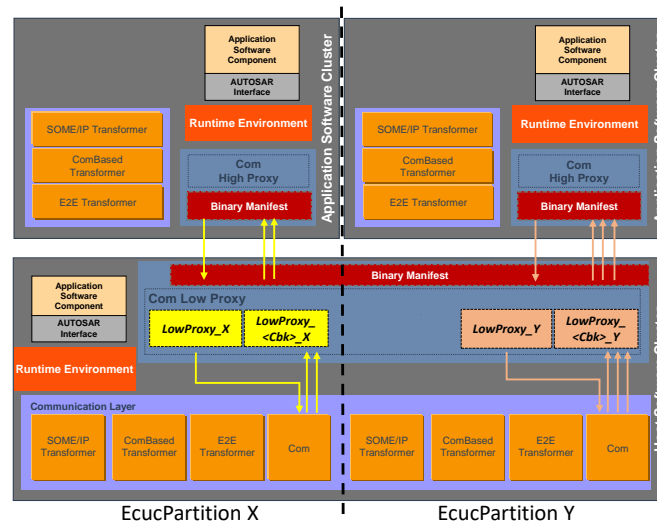

Figure 7.12: Overview of Com Proxy

The [Application Software Cluster](#) provides proxies for those parts of the Com implementation that are required to complete its functionality. This is called [Com High Proxy](#).

The [Host Software Cluster](#) contains the real implementation of the Com functionality and makes it available to the [Com High Proxy](#) via the respective [Com Low Proxy](#). Both [Com High Proxy](#) and [Com Low Proxy](#) are linked together based on the information available in [Binary Manifest](#), which enables the execution of Com (Callback) functions from [Application Software Cluster](#) to [Host Software Cluster](#) and vice-versa.

The Com Proxy as an [ComUserModule](#) is represented by one or several [ComUserModuleCnf](#). A [ComUserModuleCnf](#) is required for each [EcucPartition](#), in which the Com Proxy

- requires direct access to the Com APIs initiating transmission/reception requests of [ComSignals](#) and/or [ComSignalGroups](#)
- provides transmission/reception notification callbacks of [ComSignals](#) and/or [ComSignalGroups](#)

Effectively, a [ComUserModuleCnf](#) links a fixed set of notification callbacks in the Com to a specific [EcucPartition](#) in the Com Proxy. As consequence, the

Com Proxy has to map each `ComUserSignal` / `ComUserSignalGroup` via `ComUserSystemTemplateSystemSignalRef` / `ComUserSystemTemplateSignalGroupRef` to an `ComSignal` resp. `ComSignalGroup`.

The Com module shall provide its APIs for transmission/reception requests of the relevant `ComSignals` and/or `ComSignalGroups` on the `EcucPartition` configured in the Com Proxy.

The Com Proxy as `ComUserModule` shall provide a compatible configuration structure and content for the RTE in the `Application Software Cluster`. It derives its configuration of `ComSignals` and/or `ComSignalGroups` from the Com. For the `EcucPartition` assignment, the Com Proxy creates virtual main functions (Rx/Tx) and maps the respective `ComIPdus` to them. These main functions exist only in the configuration but do not have an implementation.

Even if the concept of Com user provides a lot of flexibility to support access by multiple users including their notifications, some limitations have to be considered.

In general, multiple writers can cause race conditions, if the writers are not coordinated. In addition, the required sequence of `Com_SendSignal` (of group signals) and `Com_SendSignalGroup` calls cause the risk of data inconsistency in case of preemption by multiple writers.

Since such a coordination across different Software Clusters is hardly achievable, the following restriction applies:

[SWS_SwCluC_CONSTR_02653]{DRAFT} [Sent signals or signal groups shall be provided to at most one `Application Software Cluster`.] (*SRS_SwCluC_00211*)

Nevertheless, reading a signal or signal group by several `Application Software Clusters` is possible.

7.4.3.3.4 General requirements

[SWS_SwCluC_02602]{DRAFT} [The Com Proxy shall support that the `ComHandleId` of `ComSignals` configured in Com of the `Host Software Cluster` can change, without reconfiguration or rebuild of the `Application Software Cluster` using these `ComSignals`.] (*SRS_SwCluC_00211*)

[SWS_SwCluC_02603]{DRAFT} [The Com Proxy shall support that the `ComHandleId` of `ComSignalGroups` resp. `ComGroupSignals` configured in the Com of the `Host Software Cluster` can change, without reconfiguration or rebuild of the `Application Software Cluster` using these `ComSignalGroups`.] (*SRS_SwCluC_00211*)

[SWS_SwCluC_02652]{DRAFT} [The Com Proxy shall support that the `ComUserCbkHandleId` of `ComUserSignals` resp. `ComUserSignalGroups` configured in

Com users of the [Application Software Cluster](#) can change, without reconfiguration or rebuild of the [Host Software Cluster](#).] ([SRS_SwCluC_00211](#))

[SWS_SwCluC_02604]{DRAFT} [The [Com Proxy](#) shall support the invocation of Com APIs from an [Application Software Cluster](#) in context of the [Host Software Cluster](#).] ([SRS_SwCluC_00211](#))

[SWS_SwCluC_02605]{DRAFT} [The [Com Proxy](#) shall support the invocation of Com callbacks from the [Host Software Cluster](#) in context of the [Application Software Cluster](#).] ([SRS_SwCluC_00211](#))

[SWS_SwCluC_02639]{DRAFT} [If the [ComUser_CbkRxAck](#) notification callback is configured in the [Com High Proxy](#) (via the [ComUserCallbackName](#) (See [\[ECUC_Com_10036\]](#))), where the respective [ComUserCallbackType](#) (See [\[ECUC_Com_10034\]](#)) is set to [COM_RX_ACK](#)) the configured [ComUser_CbkRxAck](#) callback shall be invoked when the associated [SwCluC_ComProxy_CbkRxAck](#) instance of the [Com Low Proxy](#) is called.] ([SRS_SwCluC_00211](#))

[SWS_SwCluC_02640]{DRAFT} [If the invalid [ComUser_CbkInv](#) notification callback is configured in the [Com High Proxy](#) (via the [ComUserCallbackName](#) (See [\[ECUC_Com_10036\]](#))), where the respective [ComUserCallbackType](#) (See [\[ECUC_Com_10034\]](#)) is set to [COM_RX_INV](#)) the configured [ComUser_CbkInv](#) callback shall be invoked when the associated [SwCluC_ComProxy_CbkInv](#) instance of the [Com Low Proxy](#) is called.] ([SRS_SwCluC_00211](#))

[SWS_SwCluC_02642]{DRAFT} [If the [ComUser_CbkRxTOut](#) notification callback is configured in the [Com High Proxy](#) (via the [ComUserCallbackName](#) (See [\[ECUC_Com_10036\]](#))), where the respective [ComUserCallbackType](#) (See [\[ECUC_Com_10034\]](#)) is set to [COM_RX_TOUT](#)) the configured [ComUser_CbkRxTOut](#) callback shall be invoked when the associated [SwCluC_ComProxy_CbkRxTOut](#) instance of the [Com Low Proxy](#) is called.] ([SRS_SwCluC_00211](#))

[SWS_SwCluC_02643]{DRAFT} [If the [ComUser_CbkTxAck](#) notification callback is configured in the [Com High Proxy](#) (via the [ComUserCallbackName](#) (See [\[ECUC_Com_10036\]](#))), where the respective [ComUserCallbackType](#) (See [\[ECUC_Com_10034\]](#)) is set to [COM_TX_ACK](#)) the configured [ComUser_CbkTxAck](#) callback shall be invoked when the associated instance of the [Com Low Proxy](#) is called.] ([SRS_SwCluC_00211](#))

[SWS_SwCluC_02644]{DRAFT} [If the [ComUser_CbkTxErr](#) notification callback is configured in the [Com High Proxy](#) (via the [ComUserCallbackName](#) (See [\[ECUC_Com_10036\]](#))), where the respective [ComUserCallbackType](#) (See [\[ECUC_Com_10034\]](#)) is set to [COM_TX_ERR](#)) the configured [ComUser_CbkTxErr](#) callback shall be invoked when the associated [SwCluC_ComProxy_CbkTxErr](#) instance of the [Com Low Proxy](#) is called.] ([SRS_SwCluC_00211](#))

[SWS_SwCluC_02645]{DRAFT} [If the [ComUser_CbkTxTOut](#) timeout notification callback is configured in the [Com High Proxy](#) (via the [ComUserCallbackName](#) (See [\[ECUC_Com_10036\]](#))), where the respective [ComUserCallbackType](#)

(See [ECUC_Com_10034]) is set to `COM_TX_TOUT`) the configured `<ComUser_Cbk-TxTOut>` callback shall be invoked when the associated `SwCluC_ComProxy_Cbk-TxTOut` instance of the `Com Low Proxy` is called.](SRS_SwCluC_00211)

7.4.3.3.5 Com High Proxy

[SWS_SwCluC_02606]{DRAFT} [The `Com High Proxy` shall provide the header file `Com.h`.](SRS_SwCluC_00211)

[SWS_SwCluC_02607]{DRAFT} [The `Com High Proxy` shall provide the symbolic name values for the `ComSignals`, for `Com` users in the `Application Software Cluster`.](SRS_SwCluC_00211)

[SWS_SwCluC_02608]{DRAFT} [The `Com High Proxy` shall provide the symbolic name values for the `ComSignalGroups` resp. `ComGroupSignals`, for `Com` users in the `Application Software Cluster`.](SRS_SwCluC_00211)

[SWS_SwCluC_02609]{DRAFT} [The `Com High Proxy` shall provide the functions for transmission requests of `ComSignals` and `ComSignalGroups`

- `Com_SendSignal`
- `Com_SendDynSignal`
- `Com_SendSignalGroup`
- `Com_SendSignalGroupArray`
- `Com_SendSignalWithMetaData`
- `Com_SendDynSignalWithMetaData`
- `Com_SendSignalGroupWithMetaData`
- `Com_SendSignalGroupArrayWithMetaData`

required by the `Com` users in the `Application Software Cluster`.

](SRS_SwCluC_00211, SRS_SwCluC_00202)

[SWS_SwCluC_02610]{DRAFT} [The `Com High Proxy` shall provide the functions for reception requests of a `ComSignal` and `ComSignalGroup`

- `Com_ReceiveSignal`
- `Com_ReceiveDynSignal`
- `Com_ReceiveSignalGroup`
- `Com_ReceiveSignalGroupArray`
- `Com_ReceiveSignalWithMetaData`
- `Com_ReceiveDynSignalWithMetaData`

- [Com_ReceiveSignalGroupWithMetaData](#)
- [Com_ReceiveSignalGroupArrayWithMetaData](#)

required by the Com users in the [Application Software Cluster](#)

]([SRS_SwCluC_00211](#), [SRS_SwCluC_00202](#))

[SWS_SwCluC_02648]{DRAFT} [The function [Com_ReceiveSignalGroup](#) provided by the [Com High Proxy](#) shall

- invoke the [Com_ReceiveSignalGroupArray](#) API to fetch the data as uint8 array representation, AND
- perform a transformation on the uint8 array to output the original data which will be passed to the RTE in the [Application Software Cluster](#).

]([SRS_SwCluC_00211](#))

[SWS_SwCluC_02649]{DRAFT} [The function [Com_ReceiveSignalGroupWithMetaData](#) provided by the [Com High Proxy](#) shall

- invoke the [Com_ReceiveSignalGroupArrayWithMetaData](#) API to fetch the data as uint8 array representation, AND
- perform a transformation on the uint8 array to output the original data which will be passed to the RTE in the [Application Software Cluster](#).

]([SRS_SwCluC_00211](#))

[SWS_SwCluC_02611]{DRAFT} [The [Com High Proxy](#) shall provide the functions for invalidation requests of a [ComSignal](#) and [ComSignalGroup](#)

- [Com_InvalidateSignal](#)
- [Com_InvalidateSignalGroup](#)

required by the Com users in the [Application Software Cluster](#)

]([SRS_SwCluC_00211](#), [SRS_SwCluC_00202](#))

[SWS_SwCluC_02612]{DRAFT} [If the [Com High Proxy](#) is not connected to the [Com Low Proxy](#), the functions w.r.t transmission requests of [ComSignals](#) and [ComSignalGroups](#)

- [Com_SendSignal](#)
- [Com_SendDynSignal](#)
- [Com_SendSignalGroup](#)
- [Com_SendSignalGroupArray](#)
- [Com_SendSignalWithMetaData](#)
- [Com_SendDynSignalWithMetaData](#)

- `Com_SendSignalGroupWithMetaData`
- `Com_SendSignalGroupArrayWithMetaData`

of the `Com High Proxy` shall return `COM_SERVICE_NOT_AVAILABLE`.

](*SRS_SwCluC_00211*, *SRS_SwCluC_00202*)

[SWS_SwCluC_02613]{DRAFT} [If the `Com High Proxy` is not connected to the `Com Low Proxy`, the functions w.r.t reception requests of `ComSignals` and `ComSignalGroups`

- `Com_ReceiveSignal`
- `Com_ReceiveDynSignal`
- `Com_ReceiveSignalGroup`
- `Com_ReceiveSignalGroupArray`
- `Com_ReceiveSignalWithMetaData`
- `Com_ReceiveDynSignalWithMetaData`
- `Com_ReceiveSignalGroupWithMetaData`
- `Com_ReceiveSignalGroupArrayWithMetaData`
- `Com_ReceiveSignalWithMetaData`
- `Com_ReceiveDynSignalWithMetaData`

of the `Com High Proxy` shall return `COM_SERVICE_NOT_AVAILABLE`.

](*SRS_SwCluC_00211*)

[SWS_SwCluC_02614]{DRAFT} [If the `Com High Proxy` is not connected to the `Com Low Proxy`, the functions w.r.t invalidation requests of `ComSignals` and `ComSignalGroups`

- `Com_InvalidateSignal`
- `Com_InvalidateSignalGroup`

of the `Com High Proxy` shall return `COM_SERVICE_NOT_AVAILABLE`.

](*SRS_SwCluC_00211*)

[SWS_SwCluC_02615]{DRAFT} [The `Com High Proxy` shall provide the functions for transmission request of a signal(group)s, according to **[SWS_SwCluC_02609]**, once per configured `SwCluCComProxyBaseSocket`. At the `EcucPartition` where the `SwCluCNativeBswApi` is set to `true`, For all other `SwCluCComProxyBaseSocket` instances, the `Mip Com` is replaced by `Com_<EcucPartition.ShortName>`.](*SRS_SwCluC_00211*)

[SWS_SwCluC_02616]{DRAFT} [The [Com High Proxy](#) shall provide the functions for reception request of a signal(group)s, according to [SWS_SwCluC_02610], once per configured [SwCluCComProxyBaseSocket](#). At the [EcucPartition](#) where the [SwCluCNativeBswApi](#) is set to `true`, the API is provided with the original `Mip Com`. For all the other [SwCluCComProxyBaseSocket](#) instances, the `Mip Com` is replaced by `Com_<EcucPartition.ShortName>`.] ([SRS_SwCluC_00211](#))

[SWS_SwCluC_02617]{DRAFT} [The [Com High Proxy](#) shall provide the functions for invalidation request of a signal(group)s, according to [SWS_SwCluC_02611], once per configured [SwCluCComProxyBaseSocket](#). At the [EcucPartition](#) where the [SwCluCNativeBswApi](#) is set to `true`, the API is provided with the original `Mip Com`. For all the other [SwCluCComProxyBaseSocket](#) instances, the `Mip Com` is replaced by `Com_<EcucPartition.ShortName>`.] ([SRS_SwCluC_00211](#))

Callback Functions

[SWS_SwCluC_02618]{DRAFT} [The [Com High Proxy](#) shall support the optional `<ComUser_CbkRxAck>` notification callback configured via the [ComUserCallbackName](#) (See [ECUC_Com_10036]) parameter where the [ComUserCallbackType](#) (See [ECUC_Com_10034]) is set to `COM_RX_ACK`.] ([SRS_SwCluC_00211](#), [SRS_SwCluC_00202](#))

[SWS_SwCluC_02619]{DRAFT} [The [Com High Proxy](#) shall support the optional `<ComUser_CbkInv>` notification callback configured via the [ComUserCallbackName](#) (See [ECUC_Com_10036]) where the [ComUserCallbackType](#) (See [ECUC_Com_10034]) is set to `COM_RX_INV`.] ([SRS_SwCluC_00211](#), [SRS_SwCluC_00202](#))

[SWS_SwCluC_02620]{DRAFT} [The [Com High Proxy](#) shall support the optional `<ComUser_CbkRxTOut>` timeout notification callback configured via the [ComUserCallbackName](#) (See [ECUC_Com_10036]) where the [ComUserCallbackType](#) (See [ECUC_Com_10034]) is set to `COM_RX_TOUT`.] ([SRS_SwCluC_00211](#), [SRS_SwCluC_00202](#))

[SWS_SwCluC_02621]{DRAFT} [The [Com High Proxy](#) shall support the optional `<ComUser_CbkTxAck>` notification callback configured via the [ComUserCallbackName](#) (See [ECUC_Com_10036]) where the [ComUserCallbackType](#) (See [ECUC_Com_10034]) is set to `COM_TX_ACK`.] ([SRS_SwCluC_00211](#), [SRS_SwCluC_00202](#))

[SWS_SwCluC_02622]{DRAFT} [The [Com High Proxy](#) shall support the optional `<ComUser_CbkTxErr>` error notification callback configured via the [ComUserCallbackName](#) (See [ECUC_Com_10036]) where the [ComUserCallbackType](#) (See [ECUC_Com_10034]) is set to `COM_TX_ERR`.] ([SRS_SwCluC_00211](#), [SRS_SwCluC_00202](#))

[SWS_SwCluC_02623]{DRAFT} [The [Com High Proxy](#) shall support the optional `<ComUser_CbkTxTOut>` timeout notification callback configured via the [ComUserCallbackName](#) (See [ECUC_Com_10036]) where the [ComUserCallbackType](#) (See [ECUC_Com_10034]) is set to `COM_TX_TOUT`.] ([SRS_SwCluC_00211](#), [SRS_SwCluC_00202](#))

[SWS_SwCluC_02647]{DRAFT} [The [Com High Proxy](#) shall create for each [SwCluCComProxyBaseSocket](#) a required resource entry in the [Binary Manifest](#).] ([SRS_SwCluC_00211](#))

Please note that the callbacks of the [Application Software Cluster](#)

- [<ComUser_CbkRxAck>](#)
- [<ComUser_CbkInv>](#)
- [<ComUser_CbkRxTOut>](#)
- [<ComUser_CbkTxAck>](#)
- [<ComUser_CbkTxErr>](#)
- [<ComUser_CbkTxTOut>](#)

are connected to the [Host Software Cluster](#) via the [Com base socket](#). See [\[SWS_SwCluC_02661\]](#)

In the [Application Software Cluster](#), the relationship between a Signal or a Signal Group in Com and the related [Com base socket](#) is given indirectly, via the common [EcucPartition\(s\)](#) of the [SwCluCComProxyBaseSocket.SwCluCProxyEcucPartitionRef](#) and the [ComMainFunctionRx.ComMainRxPartitionRef](#) and [ComMainFunctionTx.ComMainTxPartitionRef](#) respectively. Those relationships are illustrated in figure [7.13](#).

The reason not to define a dedicated EcuC configuration structure for this purpose, is the assumption that the same tools are used to derive the Com configuration for an [Application Software Cluster](#) and a [Host Software Cluster](#).

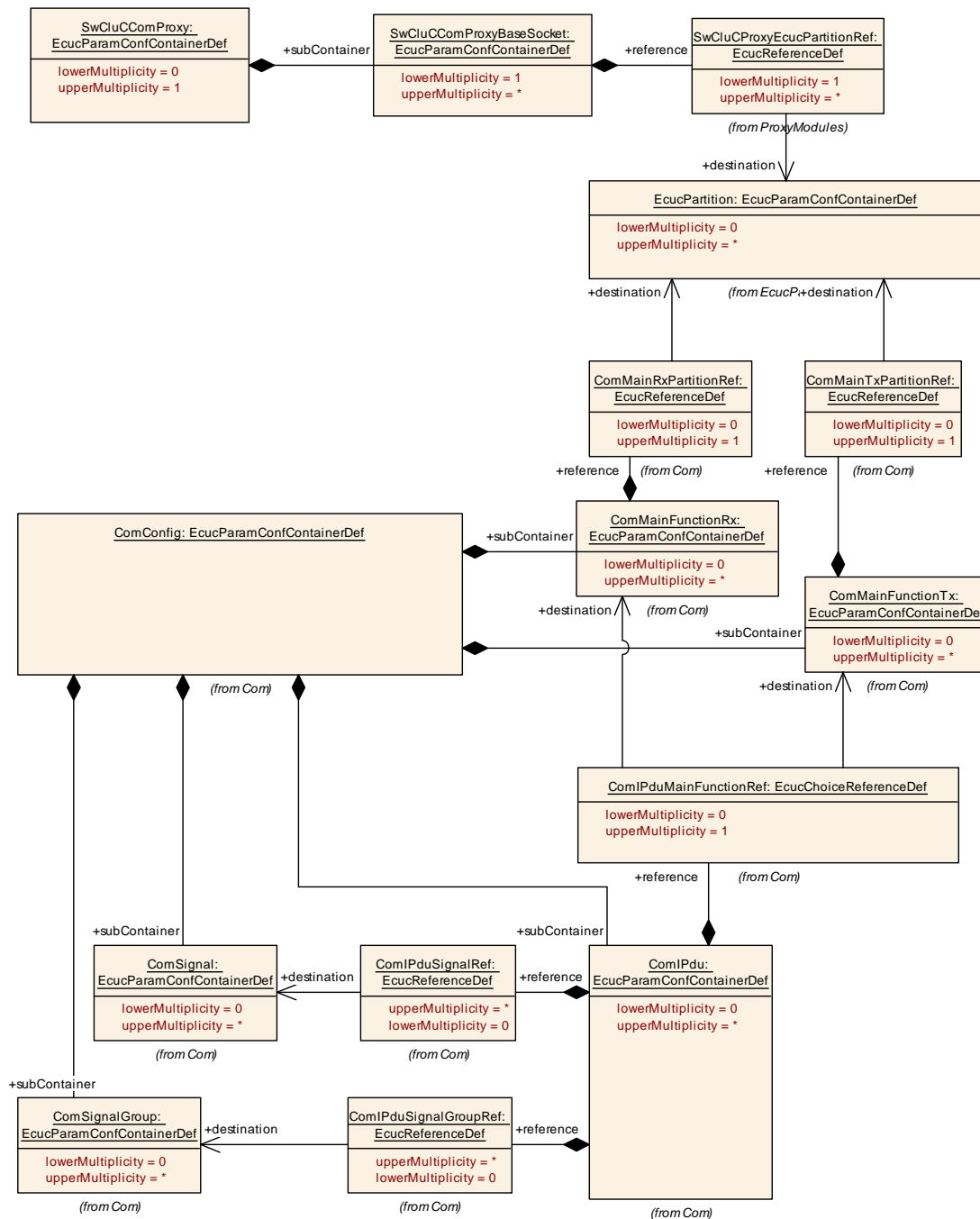

Figure 7.13: Signal or a Signal Group and their relationships to Com base sockets via EcucPartition

[SWS_SwCluC_02662]{DRAFT} [The Com High Proxy shall create for each Com-Signal and ComSignalGroup configured in Com a required resource entry in the Binary Manifest. Where the ComMainFunctionRx.ComMainRxPartitionRef and ComMainFunctionTx.ComMainTxPartitionRef are relevant to denote the EcucPartition.] (SRS_SwCluC_00211)

7.4.3.3.6 Com Low Proxy

[SWS_SwCluC_02624]{DRAFT} [The `Com Low Proxy` shall provide the header file `SwCluC_ComProxy_Cbk.h`.] ([SRS_SwCluC_00211](#))

[SWS_SwCluC_CONSTR_02654]{DRAFT} [The `ComUserHeaderInclude` parameter shall be configured as `SwCluC_ComProxy_Cbk.h`.] ([SRS_SwCluC_00211](#))

[SWS_SwCluC_02651]{DRAFT} [The `Com Low Proxy` shall provide in its `ComUserModuleCnf` containers the `ComUserCbkJHandleId` values for the configured `ComUserSignals` and `ComUserSignalGroups`, according to its internal implementation requirements (e.g. to address the `Com Low Proxy`'s data structures).] ([SRS_SwCluC_00211](#))

[SWS_SwCluC_02625]{DRAFT} [The `Com Low Proxy` shall provide the entry function for transmission, reception and invalidation requests of `ComSignal(Group)s`, according to [\[SWS_SwCluC_02609\]](#), [\[SWS_SwCluC_02610\]](#) and [\[SWS_SwCluC_02611\]](#), once per configured `SwCluCComProxyBaseSocket`, at the `EcucPartition` configured by `SwCluCComProxyBaseSocket.SwCluCProxyEcucPartitionRef`.

In case the `SwCluCComProxyUsedSatelliteRef` is set, the `EcucPartition` shall be changed, before the Com API is called.] ([SRS_SwCluC_00211](#))

The implementation of the `Com Low Proxy` may provide some basic infrastructure for the `Com High Proxy` in order to be operational. Such generic infrastructure services (including the access to COM APIs or the callbacks) can be linked between `Application Software Cluster` and `Host Software Clusters` by means of a Com base socket.

[SWS_SwCluC_02626]{DRAFT} [The `Com Low Proxy` shall provide for each `SwCluCComProxyBaseSocket` a `SwCluC_ComProxy_Init` API, to initialize the `Com High Proxy` of an `Application Software Cluster`.] ([SRS_SwCluC_00211](#))

[SWS_SwCluC_02627]{DRAFT} [The `Com Low Proxy` shall provide an instance of all `SwCluC_ComProxy_CbkRxAck` notification callbacks, configured via the `ComUserCallbackName` (See [\[ECUC_Com_10036\]](#)) parameter, with the `ComUserCallbackType` (See [\[ECUC_Com_10034\]](#)) set to `COM_RX_ACK`.] ([SRS_SwCluC_00211](#))

[SWS_SwCluC_CONSTR_02655]{DRAFT} [Each notification callback, where the parameter `ComUserCallbackType` (See [\[ECUC_Com_10034\]](#)) is set to `COM_RX_ACK`, shall be configured as `SwCluC_ComProxy_<BS>_CbkJRxAck`, where `<BS>` is the `shortName` of the `SwCluCComProxyBaseSocket` container.] ([SRS_SwCluC_00211](#))

[SWS_SwCluC_02628]{DRAFT} [The `Com Low Proxy` shall provide an instance of all `SwCluC_ComProxy_CbkInv` notification callbacks, configured on each `ComSignal(Group)` via the `ComUserCallbackName` (See [\[ECUC_Com_10036\]](#)) parameter, with the `ComUserCallbackType` (See [\[ECUC_Com_10034\]](#)) set to `COM_RX_INV`.] ([SRS_SwCluC_00211](#))

[SWS_SwCluC_CONSTR_02656]{DRAFT} [Each notification callback, where the parameter `ComUserCallbackType` (See [ECUC_Com_10034]) is set to `COM_RX_INV`, shall be configured as `SwCluC_ComProxy_<BS>_CbkJnv`, where `<BS>` is the `shortName` of the `SwCluCComProxyBaseSocket` container.] (*SRS_SwCluC_00211*)

[SWS_SwCluC_02629]{DRAFT} [The `Com Low Proxy` shall provide an instance of all `SwCluC_ComProxy_CbkRxTOut` timeout notification callbacks configured on each `ComSignal(Group)`, via the `ComUserCallbackName` (See [ECUC_Com_10036]), with the `ComUserCallbackType` (See [ECUC_Com_10034]) set to `COM_RX_TOUT`.] (*SRS_SwCluC_00211*)

[SWS_SwCluC_CONSTR_02657]{DRAFT} [Each notification callback where the parameter `ComUserCallbackType` (See [ECUC_Com_10034]) is set to `COM_RX_TOUT` shall be configured as `SwCluC_ComProxy_<BS>_CbkJRxTOut` where `<BS>` is the `shortName` of the `SwCluCComProxyBaseSocket` container.] (*SRS_SwCluC_00211*)

[SWS_SwCluC_02630]{DRAFT} [The `Com Low Proxy` shall provide an instance of all `SwCluC_ComProxy_CbkTxAck` notification callbacks configured on each `ComSignal(Group)`, via the `ComUserCallbackName` (See [ECUC_Com_10036]), with the `ComUserCallbackType` (See [ECUC_Com_10034]) set to `COM_TX_ACK`.] (*SRS_SwCluC_00211*)

[SWS_SwCluC_CONSTR_02658]{DRAFT} [Each notification callback, where the parameter `ComUserCallbackType` (See [ECUC_Com_10034]) is set to `COM_TX_ACK`, shall be configured as `SwCluC_ComProxy_<BS>_CbkJTxAck`, where `<BS>` is the `shortName` of the `SwCluCComProxyBaseSocket` container.] (*SRS_SwCluC_00211*)

[SWS_SwCluC_02631]{DRAFT} [The `Com Low Proxy` shall provide an instance of all `SwCluC_ComProxy_CbkTxErr` notification callbacks configured on each `ComSignal(Group)`, via the `ComUserCallbackName` (See [ECUC_Com_10036]), with the `ComUserCallbackType` (See [ECUC_Com_10034]) set to `COM_TX_ERR`.] (*SRS_SwCluC_00211*)

[SWS_SwCluC_CONSTR_02659]{DRAFT} [Each notification callback, where the parameter `ComUserCallbackType` (See [ECUC_Com_10034]) is set to `COM_TX_ERR`, shall be configured as `SwCluC_ComProxy_<BS>_CbkJTxErr`, where `<BS>` is the `shortName` of the `SwCluCComProxyBaseSocket` container.] (*SRS_SwCluC_00211*)

[SWS_SwCluC_02632]{DRAFT} [The `Com Low Proxy` shall provide an instance of all `SwCluC_ComProxy_CbkTxTOut` notification callbacks configured on each `ComSignal(Group)`, via the `ComUserCallbackName` (See [ECUC_Com_10036]), with the `ComUserCallbackType` (See [ECUC_Com_10034]) set to `COM_TX_TOUT`.] (*SRS_SwCluC_00211*)

[SWS_SwCluC_CONSTR_02660]{DRAFT} [Each notification callback, where the parameter `ComUserCallbackType` (See [ECUC_Com_10034]) is set to `COM_TX_TOUT`, shall be configured as `SwCluC_ComProxy_<BS>_CbkJTxTOut`, where `<BS>` is the `shortName` of the `SwCluCComProxyBaseSocket` container.] (*SRS_SwCluC_00211*)

[SWS_SwCluC_02633]{DRAFT} [The notification callback instances according to [SWS_SwCluC_02626], [SWS_SwCluC_02627], [SWS_SwCluC_02628], [SWS_SwCluC_02629], [SWS_SwCluC_02630], [SWS_SwCluC_02631] and [SWS_SwCluC_02632] are provided

- at the `EcucPartition` of the `SwCluCComProxyBaseSocket` referenced by the `SwCluCComProxyBaseSocket` - via `SwCluCComProxyUsedSatelliteRef`. In this case, the `EcucPartition` shall be changed, before the callback in the `High Proxy` is called.

](SRS_SwCluC_00211)

[SWS_SwCluC_02646]{DRAFT} [The `Com Low Proxy` shall create for each `SwCluCComProxyBaseSocket` a provided resource entry in the `Binary Manifest`.

](SRS_SwCluC_00211)

[SWS_SwCluC_02661]{DRAFT} [The `Com base socket` shall implement the connection of the related callback functions

- `SwCluC_ComProxy_CbkRxAck`
- `SwCluC_ComProxy_CbkInv`
- `SwCluC_ComProxy_CbkRxTOut`
- `SwCluC_ComProxy_CbkTxAck`
- `SwCluC_ComProxy_CbkTxErr`
- `SwCluC_ComProxy_CbkTxTOut`

](SRS_SwCluC_00211)

[SWS_SwCluC_02634]{DRAFT} [If the `Com Low Proxy` is not connected to the `Com High Proxy`, the callback functions

- `SwCluC_ComProxy_CbkRxAck`
- `SwCluC_ComProxy_CbkInv`
- `SwCluC_ComProxy_CbkRxTOut`
- `SwCluC_ComProxy_CbkTxAck`
- `SwCluC_ComProxy_CbkTxErr`
- `SwCluC_ComProxy_CbkTxTOut`

of the `Com Low Proxy` shall return without effect.](SRS_SwCluC_00211)

Conceptually, the `Com Proxy` provides `Signals` and `Signal Groups` with their corresponding notifications for a set of specific `EcucPartitions`. In the simplest case, this is a single `EcucPartition`, where also the `Com` module handles the underlying `ComIPdu`. In case the `Com` users as well as the `Com API` are unspecific to the `EcucPartition`, the `Com Proxy` can provide the same `Signals` and `Signal Groups` with

their corresponding notifications for more than one `EcucPartition`. Nevertheless, it's possible that the `Com Proxy` changes the partition for Com API access and notifications. But be aware that this may have a severe performance impact, if this is used for a larger number of Signals or Signal Groups.

In the `Host Software Cluster`, the set of Signals and Signal Groups, with their corresponding notifications, is configured by means of the `SwCluCComProxyBaseSocket.ComUserModuleCnf`. For those Signals and Signal Groups, the related entries in the `Binary Manifest` are created by the `Com Low Proxy`.

[SWS_SwCluC_02663]{DRAFT} [The `Com Low Proxy` shall create for each `ComUserSignal` and `ComUserSignalGroup` configured in a `SwCluCComProxyBaseSocket.ComUserModuleCnf` a provided resource entry in the `Binary Manifest`.] (*SRS_SwCluC_00211*)

7.4.3.3.7 Error Detection

[SWS_SwCluC_02636]{DRAFT} [If the development error detection is enabled for the `Com High Proxy`, the APIs

- `Com_SendSignal`
- `Com_SendDynSignal`
- `Com_SendSignalGroup`
- `Com_SendSignalGroupArray`
- `Com_SendSignalWithMetaData`
- `Com_SendDynSignalWithMetaData`
- `Com_SendSignalGroupWithMetaData`
- `Com_SendSignalGroupArrayWithMetaData`
- `Com_ReceiveSignal`
- `Com_ReceiveDynSignal`
- `Com_ReceiveSignalGroup`
- `Com_ReceiveSignalGroupArray`
- `Com_ReceiveSignalWithMetaData`
- `Com_ReceiveDynSignalWithMetaData`
- `Com_ReceiveSignalGroupWithMetaData`
- `Com_ReceiveSignalGroupArrayWithMetaData`
- `Com_ReceiveSignalWithMetaData`

- `Com_ReceiveDynSignalWithMetaData`
- `Com_InvalidateSignal`
- `Com_InvalidateSignalGroup`

shall report the DET error `COM_E_UNINIT`, in case the `Com High Proxy` is not initialized.]([SRS_SwCluC_00211](#), [SRS_BSW_00369](#), [SRS_BSW_00323](#), [SRS_BSW_00350](#))

[SWS_SwCluC_02637]{DRAFT} [If the development error detection is enabled for the `Com High Proxy`, the APIs

- `Com_SendSignal`
- `Com_SendDynSignal`
- `Com_SendSignalGroup`
- `Com_SendSignalGroupArray`
- `Com_SendSignalWithMetaData`
- `Com_SendDynSignalWithMetaData`
- `Com_SendSignalGroupWithMetaData`
- `Com_SendSignalGroupArrayWithMetaData`
- `Com_ReceiveSignal`
- `Com_ReceiveDynSignal`
- `Com_ReceiveSignalGroup`
- `Com_ReceiveSignalGroupArray`
- `Com_ReceiveSignalWithMetaData`
- `Com_ReceiveDynSignalWithMetaData`
- `Com_ReceiveSignalGroupWithMetaData`
- `Com_ReceiveSignalGroupArrayWithMetaData`
- `Com_ReceiveSignalWithMetaData`
- `Com_ReceiveDynSignalWithMetaData`
- `Com_InvalidateSignal`
- `Com_InvalidateSignalGroup`

shall, when invoked with a `NULL_PTR`, report the DET error `COM_E_PARAM_POINTER`.]([SRS_SwCluC_00211](#), [SRS_BSW_00369](#), [SRS_BSW_00323](#), [SRS_BSW_00350](#))

[SWS_SwCluC_02638]{DRAFT} [If the development error detection is enabled for the `Com High Proxy`, the APIs

- `Com_SendSignal`
- `Com_SendDynSignal`
- `Com_SendSignalGroup`
- `Com_SendSignalGroupArray`
- `Com_SendSignalWithMetaData`
- `Com_SendDynSignalWithMetaData`
- `Com_SendSignalGroupWithMetaData`
- `Com_SendSignalGroupArrayWithMetaData`
- `Com_ReceiveSignal`
- `Com_ReceiveDynSignal`
- `Com_ReceiveSignalGroup`
- `Com_ReceiveSignalGroupArray`
- `Com_ReceiveSignalWithMetaData`
- `Com_ReceiveDynSignalWithMetaData`
- `Com_ReceiveSignalGroupWithMetaData`
- `Com_ReceiveSignalGroupArrayWithMetaData`
- `Com_ReceiveSignalWithMetaData`
- `Com_ReceiveDynSignalWithMetaData`
- `Com_InvalidateSignal`
- `Com_InvalidateSignalGroup`

shall, when invoked with a wrong parameter, report the DET error `COM_E_PARAM.`] (*SRS_SwCluC_00211*, *SRS_BSW_00369*, *SRS_BSW_00323*, *SRS_BSW_00350*)

7.4.3.4 LdCom Proxy

7.4.3.4.1 Enable LdCom Proxy Generation

[*SWS_SwCluC_02500*]{DRAFT} [The `LdCom High Proxy` code, and related AUTOSAR model descriptions, shall only be created, if the configuration parameter `SwCluCProxyGenerationLdCom` is set to `HIGH_PROXY.`] (*SRS_SwCluC_00207*, *SRS_SwCluC_00204*)

[SWS_SwCluC_02501]{DRAFT} [The `LdCom Low Proxy` code, and related AUTOSAR model descriptions, shall only be created, if the configuration parameter `SwCluCProxyGenerationLdCom` is set to `LOW_PROXY`.] ([SRS_SwCluC_00207](#), [SRS_SwCluC_00204](#))

7.4.3.4.2 General LdCom Proxy functionality

7.4.3.4.3 Overview

With the concept of Software Clusters, which enables the splitting of the software of an AUTOSAR Classic Platform Architecture into smaller units, the `Application Software Cluster` provides proxies for those parts of the `LdCom` implementation that are required to complete its functionality. This is called `LdCom High Proxy`.

The `Host Software Cluster` contains the real implementation of the `LdCom` functionality and makes it available to the `LdCom High Proxy` via the respective `LdCom Low Proxy`. Both `LdCom High Proxy` and `LdCom Low Proxy` are linked together based on the information available in `Binary Manifest`, which enables the execution of `LdCom` (Callback) functions from `Application Software Cluster` to `Host Software Cluster` and vice-versa.

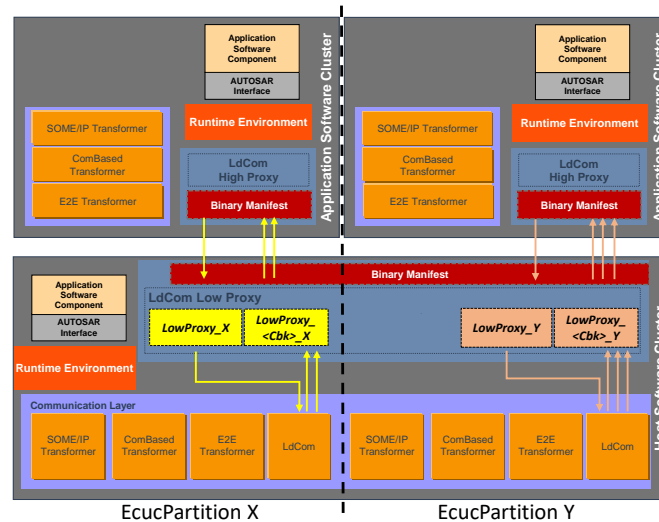

Figure 7.14: Overview of LdCom Proxy

The `LdCom` module can now have an arbitrary of users with the `LdCom Low Proxy` being one of those. It therefore relies on the usage of URI References (See [18], Section URI Reference) to be linked with its respective users in the model.

To guarantee the compatibility between configurations of the `LdCom` module and the `LdCom Proxy`, required parameters and containers are defined by the `LdComUserUriDefSet`. This means that the `LdCom Proxy` as a `LdCom` user shall configure `LdComUserModuleCnf` container (including its sub-containers), which holds the configuration of the `LdComIPdu`s it transmits and receives (via dedicated notification callbacks).

There are two alternatives, how the `LdCom Proxy` can be configured:

ECUC Partition specific `LdCom Proxy` Callbacks

Here, the `LdCom Proxy` as an `LdComUserModule` provides dedicated instances for each configured partition, on which `LdCom` (notification callback) invocations take place. This, however, mandates that it provides multiple main functions, each one bound to the relevant `EcucPartition`. The configured notification callbacks are invoked in the context of one `EcucPartition` only.

ECUC Partition agnostic `LdCom Proxy` Callbacks

Here, the `LdCom Proxy` provides partition independent notification callback instances, and therefore has to provide one common set of notification callbacks, which are invoked in the context of different `EcucPartitions`. Furthermore, it shall ensure a re-entrant implementation of the notification callbacks for different `LdComIPdu`s on different `EcucPartition`.

The `LdCom Proxy` as an `LdComUserModule` is represented by one or several `SwCluCLdComProxyBaseSockets`, configured via a dedicated `LdComUserModuleCnf`. A `SwCluCLdComProxyBaseSocket` is required for each `EcucPartition`, in which the `LdCom Proxy`

- requires direct access to the `LdCom` APIs initiating transmission requests
- provides notification callbacks w.r.t transmission and reception

Effectively, a `SwCluCLdComProxyBaseSocket` links a fixed set of notification callbacks in the `LdCom` to a specific `EcucPartition` in the `LdCom Proxy`. As a consequence, the `LdCom Proxy` has to map each `LdComUserIPdu` via `LdComUserSystemTemplateSignalRef` to an `LdComIPdu`.

The `LdCom` shall provide its APIs for transmission requests of the relevant `LdComIPdu`s on the `EcucPartition` configured in the `LdCom Proxy`. Even if the concept of `LdCom` user provides a lot of flexibility to support access by multiple users, including their notifications, some limitations need to be considered. In general, multiple writers can cause race conditions, if the writers are not coordinated. In addition, the behavior of `<LdComUser_LdComCbkJTriggerTransmit>` does not support multiple notified users for the same `LdComIPdu`. Since such a coordination across different Software Clusters is hardly achievable, the following restriction applies:

[SWS_SwCluC_CONSTR_02546]{DRAFT} [Sent `LdComIPdu` shall be provided to at most one `Application Software Cluster`.] (*SRS_SwCluC_00207*)

In addition, the LdCom Proxy does not support a fan out of LdComIPdus sent or received via transport protocol API.

[SWS_SwCluC_CONSTR_02547]{DRAFT} [LdComIPdus sent or received via transport protocol API shall be provided to at most one Application Software Cluster.](SRS_SwCluC_00207)

Please note that the PduR supports a fan-out of TP-connections to upper layers.

7.4.3.4.4 General requirements

[SWS_SwCluC_02502]{DRAFT} [The LdCom Proxy shall support that the LdComIPdu lds of the LdCom of the Host Software Cluster can change, without reconfiguration or rebuild of the Application Software Cluster using these LdComIPdus.](SRS_SwCluC_00207)

[SWS_SwCluC_02548]{DRAFT} [The LdCom Proxy shall support that the LdComUserCbchandleId of LdComUserIPdus configured in LdCom users of the Application Software Cluster can change, without reconfiguration or rebuild of the Host Software Cluster.](SRS_SwCluC_00211)

[SWS_SwCluC_02503]{DRAFT} [The LdCom Proxy shall support the invocation of LdCom API from an Application Software Cluster in context of the Host Software Cluster.](SRS_SwCluC_00207)

[SWS_SwCluC_02504]{DRAFT} [The LdCom Proxy shall support the invocation of LdCom Callback APIs from the Host Software Cluster in context of the Application Software Cluster.](SRS_SwCluC_00207)

[SWS_SwCluC_02535]{DRAFT} [If the <LdComUser_LdComCbkrxIndication> notification callback is configured in the LdCom High Proxy (via the LdComUserCallbackName (See [ECUC_LdCom_00023]) parameter, where the LdComUserCallbackType (See [ECUC_LdCom_00025]) is set to LDCOM_RX_INDICATION), all the configured <LdComUser_LdComCbkrxIndication> callbacks shall be invoked, when the associated instance of the SwCluC_LdComProxy_LdComCbkrxIndication from the LdCom Low Proxy is called.](SRS_SwCluC_00207)

[SWS_SwCluC_02536]{DRAFT} [If the <LdComUser_LdComCbktxConfirmation> notification callback is configured in the LdCom High Proxy (via the LdComUserCallbackName (See [ECUC_LdCom_00023]) parameter, where the LdComUserCallbackType (See [ECUC_LdCom_00025]) is set to LDCOM_TX_CONFIRMATION), the configured <LdComUser_LdComCbktxConfirmation> callback shall be invoked. when the associated instance of the SwCluC_LdComProxy_LdComCbktxConfirmation from the LdCom Low Proxy is called.](SRS_SwCluC_00207)

[SWS_SwCluC_02537]{DRAFT} [If the <LdComUser_LdComCbktxTriggerTransmit> notification callback is configured in the LdCom High Proxy (via the LdComUserCallbackName (See [ECUC_LdCom_00023]) parameter, where the

`LdComUserCallbackType` (See [ECUC_LdCom_00025]) is set to `LDCOM_TX_TRIGGER_TRANSMIT`), the configured `<LdComUser_LdComCbkJTriggerTransmit>` callback shall be invoked, when the associated instance of the `SwCluC_LdComProxy_LdComCbkJTriggerTransmit` from the `LdCom Low Proxy` is called.] (*SRS_SwCluC_00207*)

[SWS_SwCluC_02538]{DRAFT} [If the `<LdComUser_LdComCbkJCopyRxData>` notification callback is configured in the `LdCom High Proxy` (via the `LdComUserCallbackName` (See [ECUC_LdCom_00023]) parameter, where the `LdComUserCallbackType` (See [ECUC_LdCom_00025]) is set to `LDCOM_TP_COPY_RX_DATA`), the configured `<LdComUser_LdComCbkJCopyRxData>` callback shall be invoked, when the associated instance of the `SwCluC_LdComProxy_LdComCbkJCopyRxData` from the `LdCom Low Proxy` is called.] (*SRS_SwCluC_00207*)

[SWS_SwCluC_02539]{DRAFT} [If the `<LdComUser_LdComCbkJStartOfReception>` notification callback is configured in the `LdCom High Proxy` (via the `LdComUserCallbackName` (See [ECUC_LdCom_00023]) parameter, where the `LdComUserCallbackType` (See [ECUC_LdCom_00025]) is set to `LDCOM_RX_START_OF_RECEPTION`), the configured `<LdComUser_LdComCbkJStartOfReception>` callback shall be invoked, when the associated instance of the `SwCluC_LdComProxy_LdComCbkJStartOfReception` from the `LdCom Low Proxy` is called.] (*SRS_SwCluC_00207*)

[SWS_SwCluC_02540]{DRAFT} [If the `<LdComUser_LdComCbkJTpRxIndication>` notification callback is configured in the `LdCom High Proxy` (via the `LdComUserCallbackName` (See [ECUC_LdCom_00023]) parameter, where the `LdComUserCallbackType` (See [ECUC_LdCom_00025]) is set to `LDCOM_TP_RX_INDICATION`), the configured `<LdComUser_LdComCbkJTpRxIndication>` callback shall be invoked, when the associated instance of the `SwCluC_LdComProxy_LdComCbkJTpRxIndication` from the `LdCom Low Proxy` is called.] (*SRS_SwCluC_00207*)

[SWS_SwCluC_02541]{DRAFT} [If the `<LdComUser_LdComCbkJTpTxConfirmation>` notification callback is configured in the `LdCom High Proxy` (via the `LdComUserCallbackName` (See [ECUC_LdCom_00023]) parameter, where the `LdComUserCallbackType` (See [ECUC_LdCom_00025]) is set to `LDCOM_TP_TX_CONFIRMATION`), the configured `<LdComUser_LdComCbkJTpTxConfirmation>` callback shall be invoked, when the associated instance of the `SwCluC_LdComProxy_LdComCbkJTpTxConfirmation` from the `LdCom Low Proxy` is called.] (*SRS_SwCluC_00207*)

[SWS_SwCluC_02542]{DRAFT} [If the `<LdComUser_LdComCbkJCopyTxData>` notification callback is configured in the `LdCom High Proxy` (via the `LdComUserCallbackName` (See [ECUC_LdCom_00023]) parameter, where the `LdComUserCallbackType` (See [ECUC_LdCom_00025]) is set to `LDCOM_TP_COPY_TX_DATA`), the configured `<LdComUser_LdComCbkJCopyTxData>` callback shall be invoked, when the associated instance of the `SwCluC_LdComProxy_LdComCbkJCopyTxData` from the `LdCom Low Proxy` is called.] (*SRS_SwCluC_00207*)

7.4.3.4.5 LdCom High Proxy

[SWS_SwCluC_02505]{DRAFT} [The [LdCom High Proxy](#) shall provide the header file `LdCom.h`.] ([SRS_SwCluC_00207](#))

[SWS_SwCluC_02506]{DRAFT} [The [LdCom High Proxy](#) shall provide the symbolic name values for the `LdComIPdu` IDs, for `LdCom` users in the [Application Software Cluster](#).] ([SRS_SwCluC_00207](#))

[SWS_SwCluC_02507]{DRAFT} [The [LdCom High Proxy](#) shall provide the function w.r.t transmission request of a `LdComIPdu`

- `LdCom_Transmit`

required by the [Application Software Cluster](#)

] ([SRS_SwCluC_00207](#), [SRS_SwCluC_00202](#))

[SWS_SwCluC_02508]{DRAFT} [If the [LdCom High Proxy](#) is not connected to the [LdCom Low Proxy](#), the function

- `LdCom_Transmit`

of the [LdCom High Proxy](#) shall return `E_NOT_OK`.] ([SRS_SwCluC_00207](#))

[SWS_SwCluC_02509]{DRAFT} [The [LdCom High Proxy](#) shall provide the function for transmission request of a signal, according to [\[SWS_SwCluC_02506\]](#), once per configured `SwCluC_LdComProxyBaseSocket`. At the `EcucPartition`, where the `SwCluCNativeBswApi` is set to `true`, the API is provided with the original `MipLdCom`. For all other `SwCluC_LdComProxyBaseSocket` instances, the `MipLdCom` is replaced by `LdCom_<EcucPartition.ShortName>`.] ([SRS_SwCluC_00207](#))

Callback Functions

[SWS_SwCluC_02510]{DRAFT} [The [LdCom High Proxy](#) shall support the `<LdComUser_LdComCbkJRxIndication>` notification callback, configured via the `LdComUserCallbackName` (See [\[ECUC_LdCom_00023\]](#)) parameter, where the `LdComUserCallbackType` (See [\[ECUC_LdCom_00025\]](#)) is set to `LDCOM_RX_INDICATION`.] ([SRS_SwCluC_00207](#), [SRS_SwCluC_00202](#))

[SWS_SwCluC_02511]{DRAFT} [The [LdCom High Proxy](#) shall support the optional `<LdComUser_LdComCbkJTxConfirmation>` notification callback, configured via the `LdComUserCallbackName` (See [\[ECUC_LdCom_00023\]](#)) parameter, where the `LdComUserCallbackType` (See [\[ECUC_LdCom_00025\]](#)) is set to `LDCOM_TX_CONFIRMATION`.] ([SRS_SwCluC_00207](#), [SRS_SwCluC_00202](#))

Please note that only a single `LdCom` user can be notified with `<LdComUser_LdComCbkJTxConfirmation>`.

[SWS_SwCluC_02512]{DRAFT} [The [LdCom High Proxy](#) shall support the optional `<LdComUser_LdComCbkJTriggerTransmit>` notification callback, configured via the `LdComUserCallbackName` (See [\[ECUC_LdCom_00023\]](#)) parameter, where

the `LdComUserCallbackType` (See [ECUC_LdCom_00025]) is set to `LDCOM_TX_TRIGGER_TRANSMIT`] (*SRS_SwCluC_00207*, *SRS_SwCluC_00202*)

Please note that only a single LdCom user can be notified with `<LdComUser_LdCom-CbkTriggerTransmit>`.

[SWS_SwCluC_02513]{DRAFT} [The `LdCom High Proxy` shall support the `<LdComUser_LdComCbkCopyRxData>` notification callback, configured via the `LdComUserCallbackName` (See [ECUC_LdCom_00023]) parameter, where the `LdComUserCallbackType` (See [ECUC_LdCom_00025]) is set to `LDCOM_TP_COPY_RX_DATA`] (*SRS_SwCluC_00207*, *SRS_SwCluC_00202*)

Please note that only a single LdCom user can be notified with `<LdComUser_LdCom-CbkCopyRxData>`.

[SWS_SwCluC_02514]{DRAFT} [The `LdCom High Proxy` shall support the `<LdComUser_LdComCbkStartOfReception>` notification callback configured via the `LdComUserCallbackName` (See [ECUC_LdCom_00023]) parameter where the `LdComUserCallbackType` (See [ECUC_LdCom_00025]) is set to `LDCOM_RX_START_OF_RECEPTION`] (*SRS_SwCluC_00207*, *SRS_SwCluC_00202*)

Please note that only a single LdCom user can be notified with `<LdComUser_LdCom-CbkStartOfReception>`.

[SWS_SwCluC_02515]{DRAFT} [The `LdCom High Proxy` shall support the `<LdComUser_LdComCbkTpRxIndication>` notification callback, configured via the `LdComUserCallbackName` (See [ECUC_LdCom_00023]) parameter, where the `LdComUserCallbackType` (See [ECUC_LdCom_00025]) is set to `LDCOM_TP_RX_INDICATION`] (*SRS_SwCluC_00207*, *SRS_SwCluC_00202*)

Please note that only a single LdCom user can be notified with `<LdComUser_LdCom-CbkTpRxIndication>`.

[SWS_SwCluC_02516]{DRAFT} [The `LdCom High Proxy` shall support the `<LdComUser_LdComCbkTpTxConfirmation>` notification callback, configured via the `LdComUserCallbackName` (See [ECUC_LdCom_00023]) parameter, where the `LdComUserCallbackType` (See [ECUC_LdCom_00025]) is set to `LDCOM_TP_TX_CONFIRMATION`] (*SRS_SwCluC_00207*, *SRS_SwCluC_00202*)

Please note that only a single LdCom user can be notified with `<LdComUser_LdCom-CbkTpTxConfirmation>`.

[SWS_SwCluC_02517]{DRAFT} [The `LdCom High Proxy` shall support the `<LdComUser_LdComCbkCopyTxData>` notification callback, configured via the `LdComUserCallbackName` (See [ECUC_LdCom_00023]) parameter, where the `LdComUserCallbackType` (See [ECUC_LdCom_00025]) is set to `LDCOM_TP_COPY_TX_DATA`] (*SRS_SwCluC_00207*, *SRS_SwCluC_00202*)

Please note that only a single LdCom user can be notified with `<LdComUser_LdCom-CbkCopyTxData>`.

[SWS_SwCluC_02543]{DRAFT} [The `LdCom High Proxy` shall create, for each `SwCluCldComProxyBaseSocket`, a required resource entry in the `Binary Manifest`.] (*SRS_SwCluC_00207*)

Please note that the callbacks of the `Application Software Cluster`

- `<LdComUser_LdComCbkJStartOfReception>`
- `<LdComUser_LdComCbkJCopyRxData>`
- `<LdComUser_LdComCbkJCopyTxData>`
- `<LdComUser_LdComCbkJTriggerTransmit>`
- `<LdComUser_LdComCbkJRxIndication>`
- `<LdComUser_LdComCbkJTpRxIndication>`
- `<LdComUser_LdComCbkJTxConfirmation>`
- `<LdComUser_LdComCbkJTpTxConfirmation>`

are connected to the `Host Software Cluster` via the `LdCom base socket`. See [SWS_SwCluC_02550]

In the `Application Software Cluster`, the relationship between a `LdComUserIPdu` and the related `Base Socket` is given indirectly, via the common `EcucPartition(s)` of the `SwCluCldComProxyBaseSocket.SwCluCProxyEcucPartitionRef` and the `EcucPartition` of the `LdComIPdu`'s referenced `Pdu`. Where the `EcucPartition` of the `Pdu` is given via `Pdu.EcucPduDefaultPartitionRef` or `Pdu.EcucPduDedicatedPartition.EcucPduDedicatedPartitionRef`, where `EcucPduDedicatedPartition` applies for `LdCom` configuration. Those relationships are illustrated in figure 7.15. The reason not to define a dedicated `EcuC` configuration structure for this purpose, is the assumption that the same tools are used to derive the `LdCom` configuration for an `Application Software Cluster` and a `Host Software Cluster`.

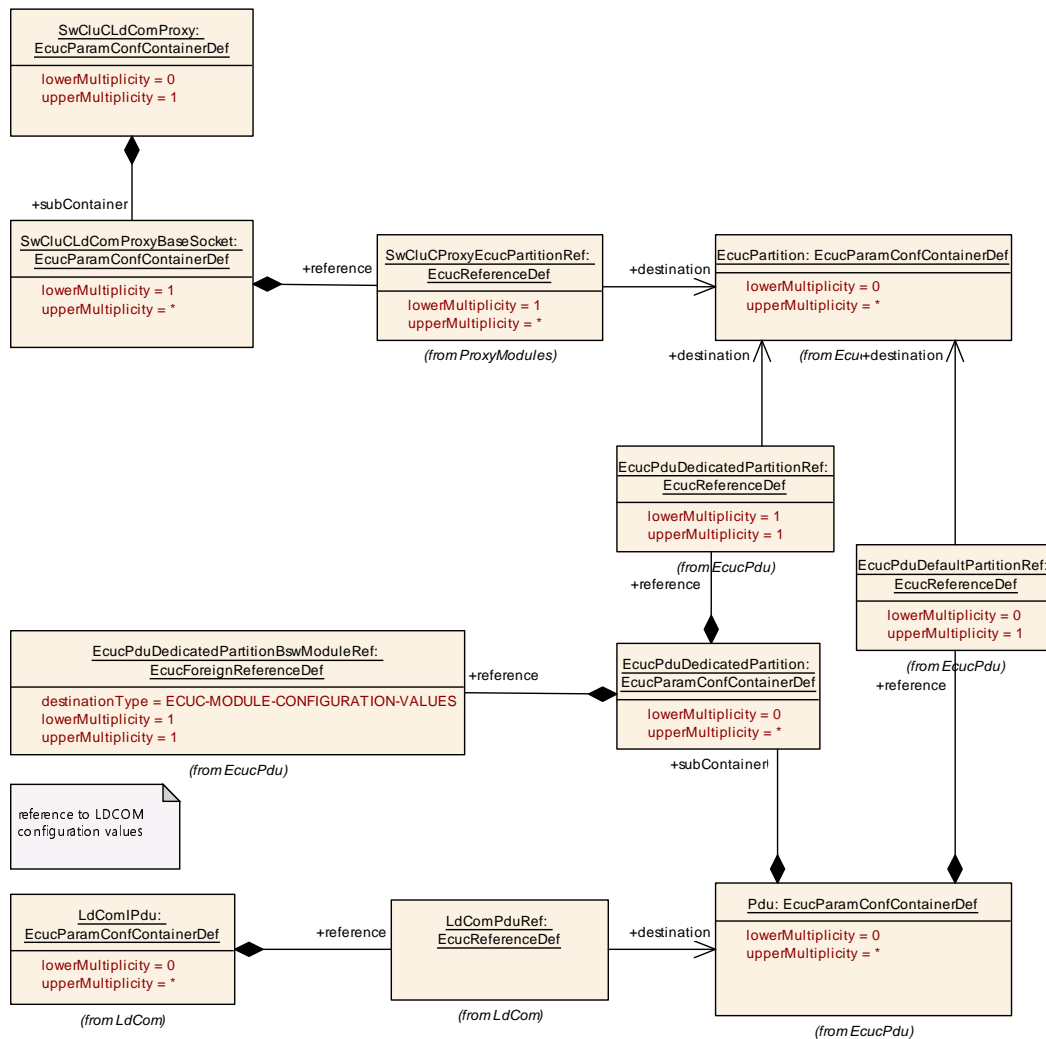

Figure 7.15: LdComIPdus and their relationships to LdCom base sockets via EcucPartition

[SWS_SwCluC_02551]{DRAFT} [The LdCom High Proxy shall create for each LdComIPdu configured in LdCom a required resource entry in the Binary Manifest. Where the EcucPartition of the LdComIPdu's Pdu given via Pdu.EcucPduDefaultPartitionRef or Pdu.EcucPduDedicatedPartition.EcucPduDedicatedPartitionRef are relevant to denote the EcucPartition.](SRS_SwCluC_00207)

7.4.3.4.6 LdCom Low Proxy

[SWS_SwCluC_02518]{DRAFT} [The LdCom Low Proxy shall provide the header file SwCluC_LdComProxy_Cbk.h.](SRS_SwCluC_00207)

[SWS_SwCluC_CONSTR_02554]{DRAFT} [The LdComUserHeaderInclude parameter shall be configured as SwCluC_LdComProxy_Cbk.h.](SRS_SwCluC_00211)

[SWS_SwCluC_02549]{DRAFT} [The `LdCom Low Proxy` shall provide in its `LdComUserModuleCnf` containers the `LdComUserCbkJHandleId` values for the configured `LdComUserIPdus`, according to its internal implementation requirements (e.g. to address the `LdCom Low Proxy`'s data structures).] (*SRS_SwCluC_00211*)

The implementation of the `LdCom Low Proxy` may provide some basic infrastructure for the `LdCom High Proxy` in order to be operational. Such generic infrastructure services (including the access to `LdCom` APIs or the callbacks) can be linked between `Application Software Cluster` and `Host Software Clusters` by means of a `LdCom` base socket.

[SWS_SwCluC_02519]{DRAFT} [The `LdCom Low Proxy` shall provide the entry function for transmission requests, according to **[SWS_SwCluC_02506]**, once per configured `SwCluC_LdComProxyBaseSocket` at the `EcucPartition` configured by `SwCluC_LdComProxyBaseSocket.SwCluCProxyEcucPartitionRef`.] (*SRS_SwCluC_00207*)

[SWS_SwCluC_02520]{DRAFT} [The `LdCom Low Proxy` shall provide for each `SwCluC_LdComProxyBaseSocket` a `SwCluC_LdComProxy_Init` API, to initialize the `LdCom High Proxy` of an `Application Software Cluster`.] (*SRS_SwCluC_00207*)

[SWS_SwCluC_02521]{DRAFT} [The `LdCom Low Proxy` shall provide an instance of all `SwCluC_LdComProxy_LdComCbkJRxIndication` notification callbacks, configured via the `LdComUserCallbackName` (See **[ECUC_LdCom_00023]**) parameter, with `LdComUserCallbackType` (See **[ECUC_LdCom_00025]**) set to `LDCOM_RX_INDICATION`.] (*SRS_SwCluC_00207*)

[SWS_SwCluC_CONSTR_02555]{DRAFT} [Each `SwCluC_LdComProxy_LdComCbkJRxIndication` notification callback, where the parameter `LdComUserCallbackType` (See **[ECUC_LdCom_00025]**) is set to `LDCOM_RX_INDICATION`, shall be configured as `SwCluC_LdComProxy_<BS>_LdComCbkJRxIndication`, where `<BS>` is the `shortName` of the `SwCluC_LdComProxyBaseSocket` container.] (*SRS_SwCluC_00207*)

[SWS_SwCluC_02522]{DRAFT} [The `LdCom Low Proxy` shall provide an instance of all `LdComCbkJTxConfirmation` notification callbacks, configured via the `LdComUserCallbackName` (See **[ECUC_LdCom_00023]**) parameter, with `LdComUserCallbackType` (See **[ECUC_LdCom_00025]**) set to `LDCOM_TX_CONFIRMATION`.] (*SRS_SwCluC_00207*)

[SWS_SwCluC_CONSTR_02556]{DRAFT} [Each `SwCluC_LdComProxy_LdComCbkJTxConfirmation` notification callback, where the parameter `LdComUserCallbackType` (See **[ECUC_LdCom_00025]**) is set to `LDCOM_TX_CONFIRMATION`, shall be configured as `SwCluC_LdComProxy_<BS>_LdComCbkJTxConfirmation`, where `<BS>` is the `shortName` of the `SwCluC_LdComProxyBaseSocket` container.] (*SRS_SwCluC_00207*)

[SWS_SwCluC_02523]{DRAFT} [The `LdCom Low Proxy` shall provide an instance of all `LdComCbkJTriggerTransmit` notification callbacks, configured via the `LdComUserCallbackName` (See [ECUC_LdCom_00023]) parameter, with `LdComUserCallbackType` (See [ECUC_LdCom_00025]) set to `LDCOM_TX_TRIGGER_TRANSMIT`.] (*SRS_SwCluC_00207*)

[SWS_SwCluC_CONSTR_02557]{DRAFT} [Each `SwCluC_LdComProxy_LdComCbkJTriggerTransmit` notification callback, where the parameter `LdComUserCallbackType` (See [ECUC_LdCom_00025]) is set to `LDCOM_TX_TRIGGER_TRANSMIT`, shall be configured as `SwCluC_LdComProxy_<BS>_LdComCbkJTriggerTransmit`, where `<BS>` is the `shortName` of the `SwCluC_LdComProxyBaseSocket` container.] (*SRS_SwCluC_00207*)

[SWS_SwCluC_02524]{DRAFT} [The `LdCom Low Proxy` shall provide an instance of all `LdComCbkJCopyRxData` notification callbacks, configured via the `LdComUserCallbackName` (See [ECUC_LdCom_00023]) parameter, with `LdComUserCallbackType` (See [ECUC_LdCom_00025]) set to `LDCOM_TP_COPY_RX_DATA`.] (*SRS_SwCluC_00207*)

[SWS_SwCluC_CONSTR_02558]{DRAFT} [Each `SwCluC_LdComProxy_LdComCbkJCopyRxData` notification callback, where the parameter `LdComUserCallbackType` (See [ECUC_LdCom_00025]) is set to `LDCOM_TP_COPY_RX_DATA`, shall be configured as `SwCluC_LdComProxy_<BS>_LdComCbkJCopyRxData`, where `<BS>` is the `shortName` of the `SwCluC_LdComProxyBaseSocket` container.] (*SRS_SwCluC_00207*)

[SWS_SwCluC_02525]{DRAFT} [The `LdCom Low Proxy` shall provide an instance of all `LdComCbkJStartOfReception` notification callbacks, configured via the `LdComUserCallbackName` (See [ECUC_LdCom_00023]) parameter, with `LdComUserCallbackType` (See [ECUC_LdCom_00025]) set to `LDCOM_RX_START_OF_RECEPTION`.] (*SRS_SwCluC_00207*)

[SWS_SwCluC_CONSTR_02559]{DRAFT} [Each `SwCluC_LdComProxy_LdComCbkJStartOfReception` notification callback, where the parameter `LdComUserCallbackType` (See [ECUC_LdCom_00025]) is set to `LDCOM_TP_COPY_RX_DATA`, shall be configured as `SwCluC_LdComProxy_<BS>_LdComCbkJCopyRxData`, where `<BS>` is the `shortName` of the `SwCluC_LdComProxyBaseSocket` container.] (*SRS_SwCluC_00207*)

[SWS_SwCluC_02526]{DRAFT} [The `LdCom Low Proxy` shall provide an instance of all `LdComCbkJTpRxIndication` notification callbacks, configured via the `LdComUserCallbackName` (See [ECUC_LdCom_00023]) parameter, with `LdComUserCallbackType` (See [ECUC_LdCom_00025]) set to `LDCOM_TP_RX_INDICATION`.] (*SRS_SwCluC_00207*)

[SWS_SwCluC_CONSTR_02560]{DRAFT} [Each `SwCluC_LdComProxy_LdComCbkJTpRxIndication` notification callback, where the parameter `LdComUserCallbackType` (See [ECUC_LdCom_00025]) is set to `LDCOM_TP_RX_INDICATION`, shall be configured as `SwCluC_LdComProxy_<BS>_LdComCbkJTpRxIndication`, where

<BS> is the `shortName` of the `SwCluCLdComProxyBaseSocket` container.]([SRS_SwCluC_00207](#))

[SWS_SwCluC_02527]{DRAFT} [The `LdCom Low Proxy` shall provide an instance of all `LdComCbkJpTxConfirmation` notification callbacks, configured via the `LdComUserCallbackName` (See [\[ECUC_LdCom_00023\]](#)) parameter, with the `LdComUserCallbackType` (See [\[ECUC_LdCom_00025\]](#)) set to `LDCOM_TP_TX_CONFIRMATION`.]([SRS_SwCluC_00207](#))

[SWS_SwCluC_CONSTR_02561]{DRAFT} [Each `SwCluC_LdComProxy_LdComCbkJpTxConfirmation` notification callback, where the parameter `LdComUserCallbackType` (See [\[ECUC_LdCom_00025\]](#)) is set to `LDCOM_TP_TX_CONFIRMATION`, shall be configured as `SwCluC_LdComProxy_<BS>_LdComCbkJpTxConfirmation`, where <BS> is the `shortName` of the `SwCluCLdComProxyBaseSocket` container.]([SRS_SwCluC_00207](#))

[SWS_SwCluC_02528]{DRAFT} [The `LdCom Low Proxy` shall provide an instance of all `SwCluC_LdComProxy_LdComCbkJCopyTxData` notification callbacks, configured via the `LdComUserCallbackName` (See [\[ECUC_LdCom_00023\]](#)) parameter, with the `LdComUserCallbackType` (See [\[ECUC_LdCom_00025\]](#)) set to `LDCOM_TP_COPY_TX_DATA`.]([SRS_SwCluC_00207](#))

[SWS_SwCluC_CONSTR_02562]{DRAFT} [Each `SwCluC_LdComProxy_LdComCbkJCopyTxData` notification callback, where the parameter `LdComUserCallbackType` (See [\[ECUC_LdCom_00025\]](#)) is set to `LDCOM_TP_COPY_TX_DATA`, shall be configured as `SwCluC_LdComProxy_<BS>_LdComCbkJCopyTxData`, where <BS> is the `shortName` of the `SwCluCLdComProxyBaseSocket` container.]([SRS_SwCluC_00207](#))

[SWS_SwCluC_02529]{DRAFT} [The notification callback instances according to [\[SWS_SwCluC_02520\]](#), [\[SWS_SwCluC_02521\]](#), [\[SWS_SwCluC_02522\]](#), [\[SWS_SwCluC_02523\]](#), [\[SWS_SwCluC_02524\]](#), [\[SWS_SwCluC_02525\]](#), [\[SWS_SwCluC_02526\]](#), [\[SWS_SwCluC_02527\]](#) and [\[SWS_SwCluC_02528\]](#) are provided

- at the `EcucPartition` of the `SwCluCLdComProxyBaseSocket`, referenced by the `SwCluCLdComProxyBaseSocket` - via `SwCluCLdComProxyUsedSatelliteRef`.

]([SRS_SwCluC_00207](#))

[SWS_SwCluC_02544]{DRAFT} [The `LdCom Low Proxy` shall create for each `SwCluCLdComProxyBaseSocket` a provided resource entry in the `Binary Manifest`.]([SRS_SwCluC_00207](#))

[SWS_SwCluC_02550]{DRAFT} [The `LdCom base socket` shall implement the connection of the related callback functions

- `SwCluC_LdComProxy_LdComCbkJStartOfReception`

- `SwCluC_LdComProxy_LdComCbkJCopyRxData`
- `SwCluC_LdComProxy_LdComCbkJCopyTxData`
- `SwCluC_LdComProxy_LdComCbkJTriggerTransmit`
- `SwCluC_LdComProxy_LdComCbkJRxIndication`
- `SwCluC_LdComProxy_LdComCbkJTpRxIndication`
- `SwCluC_LdComProxy_LdComCbkJTxConfirmation`
- `SwCluC_LdComProxy_LdComCbkJTpTxConfirmation`

](*SRS_SwCluC_00207*)

[SWS_SwCluC_02530]{DRAFT} [If the `LdCom Low Proxy` is not connected to the `LdCom High Proxy`, the notification callback functions

- `SwCluC_LdComProxy_LdComCbkJStartOfReception`
- `SwCluC_LdComProxy_LdComCbkJCopyRxData`
- `SwCluC_LdComProxy_LdComCbkJCopyTxData`

of the `LdCom Low Proxy` shall return `BUFREQ_E_NOT_OK`.](*SRS_SwCluC_00207*)

[SWS_SwCluC_02531]{DRAFT} [If the `LdCom Low Proxy` is not connected to the `LdCom High Proxy`, the notification callback function

- `SwCluC_LdComProxy_LdComCbkJTriggerTransmit`

of the `LdCom Low Proxy` shall return `E_NOT_OK`.](*SRS_SwCluC_00207*)

[SWS_SwCluC_02532]{DRAFT} [If the `LdCom Low Proxy` is not connected to the `LdCom High Proxy`, the notification callback functions

- `SwCluC_LdComProxy_LdComCbkJRxIndication`
- `SwCluC_LdComProxy_LdComCbkJTpRxIndication`
- `SwCluC_LdComProxy_LdComCbkJTxConfirmation`
- `SwCluC_LdComProxy_LdComCbkJTpTxConfirmation`

of the `LdCom Low Proxy` shall return without effect.](*SRS_SwCluC_00207*)

Conceptually, the `LdCom Proxy` provides `LdComIPdus` with their corresponding notifications for a set of specific `EcucPartitions`. In the simplest case, this is a single `EcucPartition`, where also the `LdCom` module handles the underlying `LdComIPdu`. In case the `LdCom` users as well as the `LdCom` API are unspecific to the `EcucPartition`, the `LdCom Proxy` provides the same `LdComIPdu` on multiple `EcucPartitions`. Nevertheless, it is possible that the `LdCom Proxy` changes the partition. But be aware that this may have a severe performance impact, if this is used for a larger number of `LdComIPdus`.

In the [Host Software Cluster](#), the set of [LdComIPdus](#) with their corresponding notifications is configured by means of the [SwCluCldComProxyBaseSocket.LdComUserModuleCnf](#). For those [LdComIPdus](#), the related entries in the [Binary Manifest](#) are created by the [LdCom Low Proxy](#).

[SWS_SwCluC_02552]{DRAFT} [The [LdCom Low Proxy](#) shall create, for each [LdComUserIPdu](#) configured in a [SwCluCldComProxyBaseSocket.LdComUserModuleCnf](#), a provided resource entry in the [Binary Manifest](#).] ([SRS_SwCluC_00207](#))

7.4.3.4.7 Error Detection

[SWS_SwCluC_02533]{DRAFT} [If the development error detection is enabled for the [LdCom High Proxy](#), the API

- [LdCom_Transmit](#)

shall report the DET error `LDCOM_E_UNINIT`, in case the [LdCom High Proxy](#) is not initialized.] ([SRS_SwCluC_00207](#), [SRS_BSW_00369](#), [SRS_BSW_00323](#), [SRS_BSW_00350](#))

[SWS_SwCluC_02534]{DRAFT} [If the development error detection is enabled for the [LdCom High Proxy](#), the API

- [LdCom_Transmit](#)

shall, when invoked with a `NULL_PTR`, report the DET error `LDCOM_E_PARAM_POINTER`.

] ([SRS_SwCluC_00207](#), [SRS_BSW_00369](#), [SRS_BSW_00323](#), [SRS_BSW_00350](#))

7.4.3.5 Dcm Proxy

The specified [Dcm Proxy](#) has the following underlying design principle:

For diagnostic services accessing data of the ECU's applications, the [Dcm](#) requires interfaces to the Software Components, to read or write data values or to control specific functionality. Those interfaces need to be provided by the Software Components that are implementing the regular functionality of the ECU. Therefore, the [Dcm Proxy](#) provides the functionality to route these interfaces into the [Application Software Cluster](#). The protocol, session and authentication handling stay in the [Dcm](#) of the [Host Software Cluster](#). The configuration whether a sub-service is available at all, including its properties (e.g. a data size or the required diagnostic session), is still located in the [Dcm](#).

For some diagnostic services, the [Dcm](#) offers a wide configurability with regard to how the interface to the software components is exactly implemented. E.g., the access to a diagnostic data can be done either with a client server interface for synchronous

access, or a client server interface for asynchronous access, or a sender receiver interface. Furthermore, additional sub-options are possible.

To avoid configuration dependencies from the [Host Software Cluster](#) to detailed interface decisions in the [Application Software Clusters](#), the Dcm Proxy uses a more generic interface to connect to the Dcm. The configuration of interface specialization is done in the [Application Software Clusters](#).

In general, this specification refers to the [Standardized AUTOSAR Interfaces of the Dcm](#)

7.4.3.5.1 Enable Dcm Proxy Generation

[SWS_SwCluC_02338]{DRAFT} [The [Dcm High Proxy](#) code, and related AUTOSAR model descriptions, shall only be created if the configuration parameter [SwCluCProxyGenerationDcm](#) is set to [HIGH_PROXY](#).] ([SRS_SwCluC_00208](#), [SRS_SwCluC_00204](#))

[SWS_SwCluC_02339]{DRAFT} [The [Dcm Low Proxy](#) code, and related AUTOSAR model descriptions, shall only be created if the configuration parameter [SwCluCProxyGenerationDcm](#) is set to [LOW_PROXY](#).] ([SRS_SwCluC_00208](#), [SRS_SwCluC_00204](#))

7.4.3.5.2 Dcm High Proxy

[SWS_SwCluC_02300]{DRAFT} [The [Dcm High Proxy](#) shall provide the header file [Dcm.h](#).] ([SRS_SwCluC_00208](#))

Multiple Partitions

[SWS_SwCluC_02341]{DRAFT} [The [Dcm High Proxy](#) shall create one partition specific Service Software Component per configured [EcucPartition](#), with the name [Dcm_<EcucPartition shortName>](#).] ([SRS_SwCluC_00208](#))

[SWS_SwCluC_02342]{DRAFT} [The [Dcm High Proxy](#) shall provide the Ports belonging to a specific interface connection at the partition specific Service Software Component, at the given [EcucPartition](#) of the proxy channel, configured via

- [SwCluCDcmProxyDiagnosticData.SwCluCProxyEcucPartitionRef](#)
OR
- [SwCluCDcmProxyRoutineControl.SwCluCProxyEcucPartitionRef](#)
OR
- [SwCluCDcmProxyServiceRequestNotification.SwCluCProxyEcucPartitionRef](#)

](SRS_SwCluC_00208)

Binary Manifest

The implementation of the `Dcm High Proxy` may require some basic infrastructure from the `Dcm Low Proxy` in order to be operational. Such generic infrastructure services can be linked between `Application Software Cluster` and `Host Software Cluster` by means of a `Dcm` base socket.

[SWS_SwCluC_02390]{DRAFT} [The `Dcm High Proxy` shall create for each `SwCluCdcmProxyBaseSocket` a required resource entry in the `Binary Manifest`.]()

7.4.3.5.2.1 Diagnostic Data proxy

The diagnostic data proxy provides access to diagnostic data in `Application Software Clusters`, which can be accessed by diagnostic services via the `Dcm` in the `Host Software Cluster`.

Service ID	Service name
UDS 0x22	ReadDataByIdentifier
UDS 0x24	ReadScalingDataByIdentifier
UDS 0x2E	WriteDataByIdentifier
UDS 0x2F	InputOutputControlByIdentifier
OBD \$01	Request Current Powertrain Diagnostic Data
OBD \$09	Request Vehicle Information

Table 7.3: Diagnostic Services for diagnostic data proxy

In addition, the `diagnostic data proxy` is also used by the `Dem` to access diagnostic data for freeze frame capturing.

DataServices_{Data} ports

The `DataServices_{Data}` ports are used to access single diagnostic data elements.

[SWS_SwCluC_02301]{DRAFT} [The `Dcm High Proxy` shall support the configuration of `DataServices_{Data} RPortPrototypes` for synchronous `ClientServerInterface DataServices_{Data}` for a `SwCluCdcmProxyDiagnosticData` referencing via `SwCluCdcmProxyDataRef` a `DcmDspData` or a `DcmDspPidService01`.](SRS_SwCluC_00208, SRS_SwCluC_00201)

Note: In the corresponding `Dcm` configuration, `DcmDspDataUsePort` will usually be set to `USE_DATA_SYNCH_CLIENT_SERVER`.

[SWS_SwCluC_02302]{DRAFT} [The `Dcm High Proxy` shall support the configuration of `DataServices_{Data} RPortPrototypes` for asynchronous `ClientServerInterface DataServices_{Data}` without parameter `ErrorCode`.](SRS_SwCluC_00208, SRS_SwCluC_00201)

Note: In the corresponding Dcm configuration, `DcmDspDataUsePort` will usually be set to `USE_DATA_ASYNC_CLIENT_SERVER`.

[SWS_SwCluC_02303]{DRAFT} [The `Dcm High Proxy` shall support the configuration of `DataServices_{Data} RPortPrototypes` for asynchronous `ClientServerInterface DataServices_{Data}` with parameter `ErrorCode`.] (*SRS_SwCluC_00208, SRS_SwCluC_00201*)

Note: In the corresponding Dcm configuration, `DcmDspDataUsePort` will usually be set to `USE_DATA_ASYNC_CLIENT_SERVER_ERROR`.

[SWS_SwCluC_02304]{DRAFT} [In case the `SwCluCcmProxyDiagnosticData` channel related to a `DataServices_{Data} PortPrototypes` is connected, the Dcm Proxy shall invoke the

- `ReadData operation`, when the corresponding `Xxx_ReadData API` is called in the `Dcm Low Proxy`,
OR
- `WriteData operation`, when the corresponding `Xxx_WriteData API` is called in the `Dcm Low Proxy`,
OR
- `ReadDataLength operation`, when the corresponding `Xxx_ReadDataLength API` is called in the `Dcm Low Proxy`,
OR
- `ConditionCheckRead operation`, when the corresponding `Xxx_ConditionCheckRead API` is called in the `Dcm Low Proxy`,
OR
- `GetScalingInformation operation`, when the corresponding `Xxx_GetScalingInformation API` is called in the `Dcm Low Proxy`,
OR
- `ReturnControlToEcu operation`, when the corresponding `Xxx_ReturnControlToEcu API` is called in the `Dcm Low Proxy`,
OR
- `ResetToDefault operation`, when the corresponding `Xxx_ResetToDefault API` is called in the `Dcm Low Proxy`,
OR
- `FreezeCurrentState operation`, when the corresponding `Xxx_FreezeCurrentState API` is called in the `Dcm Low Proxy`,
OR

- ShortTermAdjustment operation, when the corresponding Xxx_ShortTermAdjustment API is called in the Dcm Low Proxy.

In that case, IN arguments (Data (if applicable), OpStatus (if applicable), controlMask (if applicable) and ControlStateInfo (if applicable)) are passed to the client, and OUT arguments (Data (if applicable), ScalingInfo (if applicable), ErrorCode (if applicable)) and application errors are transferred back to the caller of the Dcm Low Proxy.](SRS_SwCluC_00208)

[SWS_SwCluC_02305]{DRAFT} [In case the operations in the DataServices_{Data} ClientServerInterface do not have a controlMask argument configured, the value is discarded without checking the passed controlMaskLength.](SRS_SwCluC_00208)

[SWS_SwCluC_02306]{DRAFT} [In case the operations in the DataServices_{Data} ClientServerInterface do not have an ErrorCode argument configured, the default value DCM_POS_RESP is transferred back to the caller of the Dcm Low Proxy in case the caller returned E_OK.](SRS_SwCluC_00208)

[SWS_SwCluC_02307]{DRAFT} [In case the DataServices_{Data} RPortPrototype is unconnected, the application error E_NOT_OK and the ErrorCode DCM_E_REQUESTOUTOFRANGE is transferred back to the caller of the Dcm Low Proxy.](SRS_SwCluC_00208)

[SWS_SwCluC_02308]{DRAFT} [In case the passed DataLength, ScalingInfoLength, or controlMaskLength (if applicable, see [SWS_SwCluC_02305]) of the caller of the Dcm Low Proxy do not match the configured data size in the Dcm configuration in the Application Software Cluster, the application error E_NOT_OK and the ErrorCode DCM_E_REQUESTOUTOFRANGE is transferred back to the caller of the Dcm Low Proxy. No data, scalingInfo or controlMask values shall be transferred in this case.](SRS_SwCluC_00208)

Please note: In case the data has dynamic length configured in the Application Software Cluster for this diagnostic data element, the DataLength cannot be checked.

DataServices_{Data} via sender-receiver / nv-data interfaces

[SWS_SwCluC_02309]{DRAFT} [The Dcm High Proxy shall support the configuration of DataServices_{Data} RPortPrototypes for SenderReceiverInterface/NvDataInterface DataServices_{Data}.](SRS_SwCluC_00208, SRS_SwCluC_00201)

Note: In the corresponding Dcm configuration, DcmDspDataUsePort will usually be set to USE_DATA_SENDER_RECEIVER or USE_DATA_SENDER_RECEIVER_AS_SERVICE AND the related parameters DcmDspDidRead will not exist AND DcmDspDidWrite will not exist.

[SWS_SwCluC_02310]{DRAFT} [The *Dcm High Proxy* shall support the configuration of *DataServices_{Data} PPortPrototypes* for *SenderReceiverInterface/NvDataInterface DataServices_{Data}*.] (*SRS_SwCluC_00208*, *SRS_SwCluC_00201*)

Note: In the corresponding *Dcm* configuration, *DcmDspDataUsePort* will usually be set to *USE_DATA_SENDER_RECEIVER* or *USE_DATA_SENDER_RECEIVER_AS_SERVICE* AND the related parameters *DcmDspDidRead* will not exist AND *DcmDspDidWrite* will exist.

[SWS_SwCluC_02311]{DRAFT} [The *Dcm High Proxy* shall support the configuration of *DataServices_{Data} PRPortPrototypes* for *SenderReceiverInterface/NvDataInterface DataServices_{Data}*.] (*SRS_SwCluC_00208*, *SRS_SwCluC_00201*)

Note: In the corresponding *Dcm* configuration, *DcmDspDataUsePort* will usually be set to *USE_DATA_SENDER_RECEIVER* or *USE_DATA_SENDER_RECEIVER_AS_SERVICE* AND the related parameters *DcmDspDidRead* will exist AND *DcmDspDidWrite* will not exist.

[SWS_SwCluC_02312]{DRAFT} [In case the *SwCluCcmProxyDiagnosticData* channel related to a *DataServices_{Data} PortPrototypes* is connected, the *Dcm Proxy* shall

- read the *dataElement/nvData*, when the corresponding *Xxx_ReadData* API is called in the *Dcm Low Proxy*,
- OR
- write the *dataElement/nvData*, when the corresponding *Xxx_WriteData* API is called in the *Dcm Low Proxy*.

In that case *IN* argument *Data* (if applicable) is sent to the receiver, and *OUT* argument *Data* (if applicable) is transferred back to the caller of the *Dcm Low Proxy*.] (*SRS_SwCluC_00208*)

[SWS_SwCluC_02313]{DRAFT} [In case the *DataServices_{Data} SenderReceiverInterface/NvDataInterface* is configured, the default value *DCM_POS_RESP* as *ErrorCode* is transferred back to the caller of the *Dcm Low Proxy* for any connected *RPortPrototype* and any connected or unconnected *PPortPrototype* or *PRPortPrototype*.] (*SRS_SwCluC_00208*)

[SWS_SwCluC_02314]{DRAFT} [In case the *DataServices_{Data} RPortPrototype*, *PPortPrototype* or *PRPortPrototype* is unconnected, the return value *E_NOT_OK* and the *ErrorCode* *DCM_E_REQUESTOUTOFRANGE* is transferred back to the caller of the *Dcm Low Proxy*.] (*SRS_SwCluC_00208*)

[SWS_SwCluC_02315]{DRAFT} [In case the passed *DataLength* of the caller of the *Dcm Low Proxy* does not match the configured data size in the *Dcm* configuration in the *Application Software Cluster*, the return value *E_NOT_OK* and the

ErrorCode DCM_E_REQUESTOUTOFRANGE is transferred back to the caller of the *Dcm Low Proxy*. No data shall be transferred in this case.](SRS_SwCluC_00208)

DataServices_{DID} ports

The DataServices_{DID} ports are used to access entire data belonging to a DID.

[SWS_SwCluC_02316]{DRAFT} [The *Dcm High Proxy* shall support the configuration of DataServices_{DID} RPortPrototypes for SenderReceiverInterface DataServices_{DID}.](SRS_SwCluC_00208, SRS_SwCluC_00201)

Note: In the corresponding *Dcm* configuration, DcmDspDidUsePort will usually be set to USE_ATOMIC_SENDER_RECEIVER_INTERFACE or USE_ATOMIC_SENDER_RECEIVER_INTERFACE_AS_SERVICE AND the related parameters DcmDspDidRead will exist AND DcmDspDidWrite will not exist OR DcmDspDidControl will exist.

[SWS_SwCluC_02317]{DRAFT} [The *Dcm High Proxy* shall support the configuration of DataServices_{DID} PPortPrototypes for SenderReceiverInterface DataServices_{DID}.](SRS_SwCluC_00208, SRS_SwCluC_00201)

Note: In the corresponding *Dcm* configuration, DcmDspDidUsePort will usually be set to USE_ATOMIC_SENDER_RECEIVER_INTERFACE or USE_ATOMIC_SENDER_RECEIVER_INTERFACE_AS_SERVICE AND the related parameters DcmDspDidRead will not exist AND DcmDspDidWrite will exist OR DcmDspDidControl will exist.

[SWS_SwCluC_02318]{DRAFT} [The *Dcm High Proxy* shall support the configuration of DataServices_{DID} PRPortPrototypes for SenderReceiverInterface DataServices_{DID}.](SRS_SwCluC_00208, SRS_SwCluC_00201)

Note: In the corresponding *Dcm* configuration, DcmDspDidUsePort will usually be set to USE_ATOMIC_SENDER_RECEIVER_INTERFACE, USE_ATOMIC_SENDER_RECEIVER_INTERFACE_AS_SERVICE, or USE_ATOMIC_NV_DATA_INTERFACE AND the related parameters DcmDspDidRead will exist AND DcmDspDidWrite will exist OR DcmDspDidControl will exist.

[SWS_SwCluC_02319]{DRAFT} [In case the SwCluCDcmProxyDiagnosticData channel related to a DataServices_{DID} PortPrototypes is connected, the *Dcm Proxy* shall

- read the dataElement, when the corresponding Xxx_ReadData API is called in the *Dcm Low Proxy*,
- OR
- write the dataElement, when the corresponding Xxx_WriteData API is called in the *Dcm Low Proxy*,

In that case, IN argument Data (if applicable) is sent to the receiver and OUT argument Data (if applicable) is transferred back to the caller of the *Dcm Low Proxy*.](SRS_SwCluC_00208)

[SWS_SwCluC_02320]{DRAFT} [In case the `DataServices_{DID}` `SenderReceiverInterface` is configured, the default value `DCM_POS_RESP` as `ErrorCode` is transferred back to the caller of the `Dcm Low Proxy` for any connected `RPortPrototype` and any connected or unconnected `PPortPrototype` or `PRPortPrototype`.] (*SRS_SwCluC_00208*)

[SWS_SwCluC_02321]{DRAFT} [In case the `DataServices_{DID}` `RPortPrototype` is unconnected, the return value `E_NOT_OK` and the `ErrorCode` `DCM_E_REQUESTOUTOFRANGE` is transferred back to the caller of the `Dcm Low Proxy`.] (*SRS_SwCluC_00208*)

[SWS_SwCluC_02322]{DRAFT} [In case the passed `DataLength` of the caller of the `Dcm Low Proxy` does not match the configured data size in the `Dcm` configuration in the `Application Software Cluster`, the return value `E_NOT_OK` and the `ErrorCode` `DCM_E_REQUESTOUTOFRANGE` is transferred back to the caller of the `Dcm Low Proxy`. No data shall be transferred in this case.] (*SRS_SwCluC_00208*)

IOControlRequest_{DID} and IOControlResponse_{DID} ports

The `IOControlRequest_{DID}` and `IOControlResponse_{DID}` sender-receiver ports are used for the Service `0x2F` - `InputOutputControlByIdentifier` as an alternative to the `DataServices_{Data}` client-server ports

[SWS_SwCluC_02323]{DRAFT} [The `Dcm High Proxy` shall support the configuration of `IOControlRequest_{DID}` `RPortPrototypes` for `SenderReceiverInterface` `IOControlRequest_{DID}`.] (*SRS_SwCluC_00208*, *SRS_SwCluC_00201*)

[SWS_SwCluC_02324]{DRAFT} [The `Dcm High Proxy` shall support the configuration of `IOControlResponse_{DID}` `RPortPrototypes` for `SenderReceiverInterface` `IOControlResponse_{DID}`.] (*SRS_SwCluC_00208*, *SRS_SwCluC_00201*)

Note: In the corresponding `Dcm` configuration, `DcmDspDidUsePort` will usually be set to `USE_ATOMIC_SENDER_RECEIVER_INTERFACE` or `USE_ATOMIC_SENDER_RECEIVER_INTERFACE_AS_SERVICE` and the related container `DcmDspDid` will exist.

[SWS_SwCluC_02325]{DRAFT} [In case the `SwCluCdcmProxyDiagnosticData` channel, related to a `IOControlRequest_{DID}` and `IOControlResponse_{DID}` sender-receiver port, is connected, the `Dcm Proxy` shall:

- calculate the `underControl`, `IOOperationRequest` and `controlState` data elements, according to [SWS_Dcm_01435], [SWS_Dcm_00682], [SWS_Dcm_01436], [SWS_Dcm_01437], [SWS_Dcm_01438], [SWS_Dcm_01275], [SWS_Dcm_01277] AND

- return the `IOperationResponse`, according to [SWS_Dcm_01439], [SWS_Dcm_01440], and [SWS_Dcm_01441], when the corresponding `Xxx_ReadData`, `Xxx_WriteData`, `Xxx_ReturnControlToEcu`, `Xxx_ResetToDefault`, `Xxx_FreezeCurrentState`, or `Xxx_ShortTermAdjustment` API is called in the `Dcm Low Proxy`.

](SRS_SwCluC_00208)

Binary Manifest

[SWS_SwCluC_02391]{DRAFT} [The `Dcm High Proxy` shall create for each `diagnostic data proxy` - configured via `SwCluCdcmProxyDiagnosticData` container - a provided resource entry in the `Binary Manifest`.]()

7.4.3.5.2.2 Routine Control proxy

The `routine control proxy` provides access to routine control services in `Application Software Clusters`, which can be accessed by UDS diagnostic services `0x31 RoutineControl` via the `Dcm` in the `Host Software Cluster`.

RoutineServices_{RoutineName} ports

[SWS_SwCluC_02330]{DRAFT} [The `Dcm High Proxy` shall support the configuration of `RoutineServices_{RoutineName} RPortPrototypes` for `ClientServerInterface RoutineServices_{RoutineName}`.](SRS_SwCluC_00208, SRS_SwCluC_00201)

[SWS_SwCluC_02331]{DRAFT} [In case the `SwCluCdcmProxyRoutineControl` channel related to a `RoutineServices_{RoutineName} RPortPrototypes` is connected, the `Dcm Proxy` shall invoke the

- `Start operation`, when the corresponding `Xxx_Start` API is called in the `Dcm Low Proxy`,
OR
- `StartConfirmation operation`, when the corresponding `Xxx_StartConfirmation` API is called in the `Dcm Low Proxy`,
OR
- `Stop operation`, when the corresponding `Xxx_Stop` API is called in the `Dcm Low Proxy`,
OR
- `StopConfirmation operation`, when the corresponding `Xxx_StopConfirmation` API is called in the `Dcm Low Proxy`,
OR

- RequestResults operation, when the corresponding Xxx_RequestResults API is called in the Dcm Low Proxy,

OR

- RequestResultsConfirmation operation, when the corresponding Xxx_RequestResultsConfirmation API is called in the Dcm Low Proxy,

In this case, INOUT arguments (dataInOut (if applicable)) are used to transfer the individual dataIn signals to the client, and to transfer back the individual dataOut signals as joint array to the caller of the Dcm Low Proxy. The configuration of the operations in the ClientServerInterfaces is according to the Dcm configuration of the Application Software Cluster. Additionally, IN arguments OpStatus (if applicable) and ConfirmationStatus (if applicable) are passed to the client, and OUT arguments ErrorCode (if applicable) and application errors are transferred back to the caller of the Dcm Low Proxy.](SRS_SwCluC_00208)

[SWS_SwCluC_02332]{DRAFT} [In case the RoutineServices_{RoutineName} RPortPrototype is unconnected, the return value E_NOT_OK and the ErrorCode DCM_E_REQUESTOUTOFRANGE (if applicable) is transferred back to the caller of the Dcm Low Proxy.](SRS_SwCluC_00208)

[SWS_SwCluC_02333]{DRAFT} [In case the passed DataLength of the caller of the Dcm Low Proxy does not match the configured data size in the Dcm configuration in the Application Software Cluster, the return value E_NOT_OK and the ErrorCode DCM_E_REQUESTOUTOFRANGE is transferred back to the caller of the Dcm Low Proxy. No data shall be transferred in this case.](SRS_SwCluC_00208)

Please note: In case dynamic length signals are configured in the Application Software Cluster for this routine control, the DataLength cannot be checked.

Binary Manifest

[SWS_SwCluC_02392]{DRAFT} [The Dcm High Proxy shall create for each routine control proxy - configured via SwCluCdcmProxyRoutineControl container - a provided resource entry in the Binary Manifest.](SRS_SwCluC_00208)

7.4.3.5.2.3 Service Request Notification proxy

The service request notification proxy provides access to the service request manufacturer notification and service request supplier notification

ServiceRequestManufacturerNotification_{Name} ports

[SWS_SwCluC_02334]{DRAFT} [The Dcm High Proxy shall support the configuration of ServiceRequestManufacturerNotification_{Name} RPortPrototypes for ClientServerInterface ServiceRequestManufacturerNotification_{Name}.](SRS_SwCluC_00208, SRS_SwCluC_00201)

ServiceRequestSupplierNotification_{Name} ports

[SWS_SwCluC_02335]{DRAFT} [The `Dcm High Proxy` shall support the configuration of `ServiceRequestSupplierNotification_{Name}` `RPortPrototypes` for `ClientServerInterface` `ServiceRequestSupplierNotification_{Name}`.]([SRS_SwCluC_00208](#))

[SWS_SwCluC_02336]{DRAFT} [In case the `SwCluCdcmProxyServiceRequestNotification` channel related to a `ServiceRequestManufacturerNotification_{Name}` or `ServiceRequestSupplierNotification_{Name}` `RPortPrototypes` is connected, the `Dcm Proxy` shall invoke the

- Confirmation operation, when the corresponding `Xxx_Confirmation` API is called in the `Dcm Low Proxy`,
- OR
- Indication operation, when the corresponding `Xxx_Indication` API is called in the `Dcm Low Proxy`.

In this case, IN arguments [`SID` (if applicable), `ReqType` (if applicable), `ConnectionId` (if applicable), `ConfirmationStatus` (if applicable), `ProtocolType` (if applicable), `TesterSourceAddress` (if applicable), `RequestData` (if applicable), `DataSize` (if applicable)] are passed to the client and OUT arguments [`ErrorCode` (if applicable)] and application errors are transferred back to the caller of the `Dcm Low Proxy`.]([SRS_SwCluC_00208](#))

[SWS_SwCluC_02337]{DRAFT} [In case the `ServiceRequestManufacturerNotification_{Name}` or `ServiceRequestSupplierNotification_{Name}` `RPortPrototype` is unconnected, the return value `E_NOT_OK` and the `ErrorCode` `DCM_E_REQUESTOUTOFRANGE` (if applicable) is transferred back to the caller of the `Dcm Low Proxy`.]([SRS_SwCluC_00208](#))

Binary Manifest

[SWS_SwCluC_02393]{DRAFT} [The `Dcm High Proxy` shall create for each `service request notification proxy` - configured via `SwCluCdcmProxyServiceRequestNotification` container - a provided resource entry in the `Binary Manifest`.]()

7.4.3.5.3 Dcm Low Proxy

7.4.3.5.3.1 Diagnostic Data proxy

ReadData

[SWS_SwCluC_02350]{DRAFT} [The `Dcm Low Proxy` shall provide an instance of a `Xxx_ReadData` function per configured `SwCluCdcmProxyDiagnosticData` container in the `Dcm Low Proxy`, if the `diagnostic data element read access` is enabled.]([SRS_SwCluC_00208](#))

[SWS_SwCluC_02351]{DRAFT} [The `Xxx_ReadData` function shall be named `SwCluC_DcmProxy_ReadData_<DDSN>`, where `<DDSN>` is the `shortName` of the `SwCluCDcmProxyRoutineControl` container.]([SRS_SwCluC_00208](#))

[SWS_SwCluC_02352]{DRAFT} [The diagnostic data element read access for a `SwCluCDcmProxyDiagnosticData` is enabled, if:

- `SwCluCDcmProxyDataRef` references a `DcmDspData` AND the corresponding `DcmDspDid` has a `DcmDspDidRead` configured in its related `DcmDspDidInfo`
- OR
- `SwCluCDcmProxyDataRef` references a `DcmDspDid`, which has a `DcmDspDidRead` configured in its related `DcmDspDidInfo`
- OR
- `SwCluCDcmProxyDataRef` references a `DcmDspPidService01`
- OR
- `SwCluCDcmProxyDataRef` references a `DemDataElementClass`

]([SRS_SwCluC_00208](#))

[SWS_SwCluC_02380]{DRAFT} [The `Xxx_ReadData` function of `Dcm Low Proxy` shall return `E_NOT_OK` and the `ErrorCode` `DCM_E_REQUESTOUTOFRANGE`, if the corresponding `diagnostic data proxy` is not connected to an instance in the `Dcm High Proxy`. No data is returned in this case.]([SRS_SwCluC_00208](#))

WriteData

[SWS_SwCluC_02353]{DRAFT} [The `Dcm Low Proxy` shall provide an instance of a `Xxx_WriteData` function per configured `SwCluCDcmProxyDiagnosticData` container in the `Dcm Low Proxy`, if the `diagnostic data element write access` is enabled.]([SRS_SwCluC_00208](#))

[SWS_SwCluC_02354]{DRAFT} [The `Xxx_WriteData` function shall be named `SwCluC_DcmProxy_WriteData_<DDSN>`, where `<DDSN>` is the `shortName` of the `SwCluCDcmProxyRoutineControl` container.]([SRS_SwCluC_00208](#))

[SWS_SwCluC_02355]{DRAFT} [The diagnostic data element write access for a `SwCluCDcmProxyDiagnosticData` is enabled, if:

- `SwCluCDcmProxyDataRef` references a `DcmDspData` AND the corresponding `DcmDspDid` has a `DcmDspDidWrite` configured in its related `DcmDspDidInfo`
- OR
- `SwCluCDcmProxyDataRef` references a `DcmDspDid`, which has a `DcmDspDidWrite` configured in its related `DcmDspDidInfo`

]([SRS_SwCluC_00208](#))

[SWS_SwCluC_02381]{DRAFT} [The `Xxx_WriteData` function of `Dcm Low Proxy` shall return `E_NOT_OK` and the `ErrorCode` `DCM_E_REQUESTOUTOFRANGE`, if the corresponding `diagnostic data proxy` is not connected to an instance in the `Dcm High Proxy`.] (*SRS_SwCluC_00208*)

ReadDataLength

[SWS_SwCluC_02356]{DRAFT} [The `Dcm Low Proxy` shall provide an instance of a `Xxx_ReadDataLength` function per configured `SwCluC_DcmProxyDiagnosticData` container in the `Dcm Low Proxy`, if the `diagnostic data element read data length access` is enabled.] (*SRS_SwCluC_00208*)

[SWS_SwCluC_02357]{DRAFT} [The `Xxx_ReadDataLength` function shall be named `SwCluC_DcmProxy_ReadDataLength_<DDSN>`, where `<DDSN>` is the `shortName` of the `SwCluC_DcmProxyRoutineControl` container.] (*SRS_SwCluC_00208*)

[SWS_SwCluC_02358]{DRAFT} [The `diagnostic data element read data length access` for a `SwCluC_DcmProxyDiagnosticData` is enabled, if:

- `SwCluC_DcmProxyDataRef` references a `DcmDspData` AND the corresponding `DcmDspDid` has a `DcmDspDidRead` configured in its related `DcmDspDidInfo`
AND
- the `DcmDspDataType` is set to `UINT8_DYN`.

] (*SRS_SwCluC_00208*)

[SWS_SwCluC_02382]{DRAFT} [The `Xxx_ReadDataLength` function of `Dcm Low Proxy` shall return `E_NOT_OK`, if the corresponding `diagnostic data proxy` is not connected to an instance in the `Dcm High Proxy`.] (*SRS_SwCluC_00208*)

ConditionCheckRead

[SWS_SwCluC_02359]{DRAFT} [The `Dcm Low Proxy` shall provide an instance of a `Xxx_ConditionCheckRead` function per configured `SwCluC_DcmProxyDiagnosticData` container in the `Dcm Low Proxy`, if the `diagnostic data element condition check read access` is enabled.] (*SRS_SwCluC_00208*)

[SWS_SwCluC_02360]{DRAFT} [The `Xxx_ConditionCheckRead` function shall be named `SwCluC_DcmProxy_ConditionCheckRead_<DDSN>`, where `<DDSN>` is the `shortName` of the `SwCluC_DcmProxyRoutineControl` container.] (*SRS_SwCluC_00208*)

[SWS_SwCluC_02361]{DRAFT} [The `diagnostic data element condition check read access` for a `SwCluC_DcmProxyDiagnosticData` is enabled, if:

- `SwCluC_DcmProxyDataRef` references a `DcmDspData` AND the corresponding `DcmDspDid` has a `DcmDspDidRead` configured in its related `DcmDspDidInfo`
AND

- the parameter `DcmDspDataConditionCheckReadFncUsed` is set to `true`.

](SRS_SwCluC_00208)

[SWS_SwCluC_02383]{DRAFT} [The `Xxx_ConditionCheckRead` function of `Dcm Low Proxy` shall return `E_NOT_OK`, if the corresponding `diagnostic data proxy` is not connected to an instance in the `Dcm High Proxy`.](SRS_SwCluC_00208)

GetScalingInformation

[SWS_SwCluC_02362]{DRAFT} [The `Dcm Low Proxy` shall provide an instance of a `Xxx_GetScalingInformation` function per configured `SwCluC Dcm Proxy DiagnosticData` container in the `Dcm Low Proxy`, if the `diagnostic data element scaling information access` is enabled.](SRS_SwCluC_00208)

[SWS_SwCluC_02363]{DRAFT} [The `Xxx_GetScalingInformation` function shall be named `SwCluC_DcmProxy_GetScalingInformation_<DDSN>`, where `<DDSN>` is the `shortName` of the `SwCluC Dcm Proxy RoutineControl` container.](SRS_SwCluC_00208)

[SWS_SwCluC_02364]{DRAFT} [The `diagnostic data element scaling information access` for a `SwCluC Dcm Proxy DiagnosticData` is enabled, if:

- `SwCluC Dcm Proxy DataRef` references a `DcmDspData`

AND

- the corresponding `DcmDspDataScalingInfoSize` is configured in its related `DcmDspDataInfo`.

](SRS_SwCluC_00208)

[SWS_SwCluC_02384]{DRAFT} [The `Xxx_GetScalingInformation` function of `Dcm Low Proxy` shall return `E_NOT_OK`, if the corresponding `diagnostic data proxy` is not connected to an instance in the `Dcm High Proxy`.](SRS_SwCluC_00208)

ReturnControlToECU

[SWS_SwCluC_02365]{DRAFT} [The `Dcm Low Proxy` shall provide an instance of a `Xxx_ReturnControlToECU` function per configured `SwCluC Dcm Proxy DiagnosticData` container in the `Dcm Low Proxy`, if the `diagnostic data element return control to ECU` is enabled.](SRS_SwCluC_00208)

[SWS_SwCluC_02366]{DRAFT} [The `Xxx_ReturnControlToECU` function shall be named `SwCluC_DcmProxy_ReturnControlToECU_<DDSN>`, where `<DDSN>` is the `shortName` of the `SwCluC Dcm Proxy RoutineControl` container.](SRS_SwCluC_00208)

[SWS_SwCluC_02367]{DRAFT} [The `diagnostic data element return control to ECU` for a `SwCluC Dcm Proxy DiagnosticData` is enabled, if:

- `SwCluC Dcm Proxy DataRef` references a `DcmDspData`

AND

- the corresponding `DcmDspDid` has a `DcmDspDidControl` configured in its related `DcmDspDidInfo`

AND

- the parameter `DcmDspDidFreezeCurrentState` is set to `true`.

]([SRS_SwCluC_00208](#))

[SWS_SwCluC_02385]{DRAFT} [The `Xxx_ReturnControlToECU` function of `Dcm Low Proxy` shall return `E_NOT_OK`, if the corresponding `diagnostic data proxy` is not connected to an instance in the `Dcm High Proxy`.]([SRS_SwCluC_00208](#))

ResetToDefault

[SWS_SwCluC_02368]{DRAFT} [The `Dcm Low Proxy` shall provide an instance of a `Xxx_ResetToDefault` function per configured `SwCluCdcmProxyDiagnosticData` container in the `Dcm Low Proxy`, if the `diagnostic data element reset to default` is enabled.]([SRS_SwCluC_00208](#))

[SWS_SwCluC_02369]{DRAFT} [The `Xxx_ResetToDefault` function shall be named `SwCluC_DcmProxy_ResetToDefault_<DDSN>`, where `<DDSN>` is the `shortName` of the `SwCluCdcmProxyRoutineControl` container.]([SRS_SwCluC_00208](#))

[SWS_SwCluC_02370]{DRAFT} [The `diagnostic data element reset to default` for a `SwCluCdcmProxyDiagnosticData` is enabled, if:

- `SwCluCdcmProxyDataRef` references a `DcmDspData`

AND

- the corresponding `DcmDspDid` has a `DcmDspDidControl` configured in its related `DcmDspDidInfo`

AND

- the parameter `DcmDspDidResetToDefault` is set to `true`.

]([SRS_SwCluC_00208](#))

[SWS_SwCluC_02386]{DRAFT} [The `Xxx_ResetToDefault` function of `Dcm Low Proxy` shall return `E_NOT_OK`, if the corresponding `diagnostic data proxy` is not connected to an instance in the `Dcm High Proxy`.]([SRS_SwCluC_00208](#))

FreezeCurrentState

[SWS_SwCluC_02371]{DRAFT} [The `Dcm Low Proxy` shall provide an instance of a `Xxx_FreezeCurrentState` function per configured `SwCluCdcmProxyDiagnosticData` container in the `Dcm Low Proxy`, if the `diagnostic data element freeze current state` is enabled.]([SRS_SwCluC_00208](#))

[SWS_SwCluC_02372]{DRAFT} [The `Xxx_FreezeCurrentState` function shall be named `SwCluC_DcmProxy_FreezeCurrentState_<DDSN>`, where `<DDSN>` is the `shortName` of the `SwCluCDcmProxyRoutineControl` container.](SRS_SwCluC_00208)

[SWS_SwCluC_02373]{DRAFT} [The diagnostic data element `freeze current state` for a `SwCluCDcmProxyDiagnosticData` is enabled, if

- `SwCluCDcmProxyDataRef` references a `DcmDspData`

AND

- the corresponding `DcmDspDid` has a `DcmDspDidControl` configured in its related `DcmDspDidInfo`

AND

- the parameter `DcmDspDidFreezeCurrentState` is set to `true`.

](SRS_SwCluC_00208)

[SWS_SwCluC_02387]{DRAFT} [The `Xxx_FreezeCurrentState` function of `Dcm Low Proxy` shall return `E_NOT_OK`, if the corresponding `diagnostic data proxy` is not connected to an instance in the `Dcm High Proxy`.](SRS_SwCluC_00208)

ShortTermAdjustment

[SWS_SwCluC_02374]{DRAFT} [The `Dcm Low Proxy` shall provide an instance of a `Xxx_ShortTermAdjustment` function per configured `SwCluCDcmProxyDiagnosticData` container in the `Dcm Low Proxy`, if the `diagnostic data element short term adjustment` is enabled.](SRS_SwCluC_00208)

[SWS_SwCluC_02375]{DRAFT} [The `Xxx_ShortTermAdjustment` function shall be named `SwCluC_DcmProxy_ShortTermAdjustment_<DDSN>`, where `<DDSN>` is the `shortName` of the `SwCluCDcmProxyRoutineControl` container.](SRS_SwCluC_00208)

[SWS_SwCluC_02376]{DRAFT} [The diagnostic data element `short term adjustment` for a `SwCluCDcmProxyDiagnosticData` is enabled, if

- `SwCluCDcmProxyDataRef` references a `DcmDspData`

AND

- the corresponding `DcmDspDid` has a `DcmDspDidControl` configured in its related `DcmDspDidInfo`

AND

- the parameter `DcmDspDidShortTermAdjustment` is set to `true`.

](SRS_SwCluC_00208)

[SWS_SwCluC_02388]{DRAFT} [The `Xxx_ShortTermAdjustment` function of `Dcm Low Proxy` shall return `E_NOT_OK`, if the corresponding `diagnostic data proxy` is not connected to an instance in the `Dcm High Proxy`.] (*SRS_SwCluC_00208*)

Binary Manifest

[SWS_SwCluC_02394]{DRAFT} [The `Dcm Low Proxy` shall create for each `diagnostic data proxy` - configured via `SwCluCdcmProxyDiagnosticData` container - a required resource entry in the `Binary Manifest`.] ()

7.4.3.5.3.2 Routine Control proxy

Start Operation

[SWS_SwCluC_02400]{DRAFT} [The `Dcm Low Proxy` shall provide an instance of a `Xxx_Start` function per configured `SwCluCdcmProxyRoutineControl` container in the `Dcm Low Proxy`.] (*SRS_SwCluC_00208*)

[SWS_SwCluC_02401]{DRAFT} [The `Xxx_Start` function shall be named `SwCluC_DcmProxy_Start_<RCSN>`, where `<RCSN>` is the `shortName` of the `SwCluCdcmProxyRoutineControl` container.] (*SRS_SwCluC_00208*)

[SWS_SwCluC_02402]{DRAFT} [The `Xxx_Start` function of `Dcm Low Proxy` shall return `E_NOT_OK` and the `ErrorCode` `DCM_E_REQUESTOUTOFRANGE`, if the corresponding `routine control proxy` is not connected to an instance in the `Dcm High Proxy`.] (*SRS_SwCluC_00208*)

StartConfirmation Operation

[SWS_SwCluC_02403]{DRAFT} [The `Dcm Low Proxy` shall provide an instance of a `Xxx_StartConfirmation` function per configured `SwCluCdcmProxyRoutineControl` container in the `Dcm Low Proxy`.] (*SRS_SwCluC_00208*)

[SWS_SwCluC_02404]{DRAFT} [The `Xxx_StartConfirmation` function shall be named `SwCluC_DcmProxy_StartConfirmation_<RCSN>`, where `<RCSN>` is the `shortName` of the `SwCluCdcmProxyRoutineControl` container.] (*SRS_SwCluC_00208*)

[SWS_SwCluC_02405]{DRAFT} [The `Xxx_StartConfirmation` function of `Dcm Low Proxy` shall return `E_NOT_OK`, if the corresponding `routine control proxy` is not connected to an instance in the `Dcm High Proxy`.] (*SRS_SwCluC_00208*)

Stop Operation

[SWS_SwCluC_02406]{DRAFT} [The `Dcm Low Proxy` shall provide an instance of a `Xxx_Stop` function per configured `SwCluCdcmProxyRoutineControl` container in the `Dcm Low Proxy`.] (*SRS_SwCluC_00208*)

[SWS_SwCluC_02407]{DRAFT} [The `Xxx_Stop` function shall be named `SwCluC_DcmProxy_Stop_<RCSN>`, where `<RCSN>` is the `shortName` of the `SwCluCDcmProxyRoutineControl` container.]([SRS_SwCluC_00208](#))

[SWS_SwCluC_02408]{DRAFT} [The `Xxx_Stop` function of `Dcm Low Proxy` shall return `E_NOT_OK` and the `ErrorCode` `DCM_E_REQUESTOUTOFRANGE`, if the corresponding `routine control proxy` is not connected to an instance in the `Dcm High Proxy`.]([SRS_SwCluC_00208](#))

StopConfirmation Operation

[SWS_SwCluC_02409]{DRAFT} [The `Dcm Low Proxy` shall provide an instance of a `Xxx_StopConfirmation` function per configured `SwCluCDcmProxyRoutineControl` container in the `Dcm Low Proxy`.]([SRS_SwCluC_00208](#))

[SWS_SwCluC_02410]{DRAFT} [The `Xxx_StopConfirmation` function shall be named `SwCluC_DcmProxy_StopConfirmation_<RCSN>`, where `<RCSN>` is the `shortName` of the `SwCluCDcmProxyRoutineControl` container.]([SRS_SwCluC_00208](#))

[SWS_SwCluC_02411]{DRAFT} [The `Xxx_StopConfirmation` function of `Dcm Low Proxy` shall return `E_NOT_OK` if the corresponding `routine control proxy` is not connected to an instance in the `Dcm High Proxy`.]([SRS_SwCluC_00208](#))

RequestResults Operation

[SWS_SwCluC_02412]{DRAFT} [The `Dcm Low Proxy` shall provide an instance of a `Xxx_RequestResults` function per configured `SwCluCDcmProxyRoutineControl` container in the `Dcm Low Proxy`.]([SRS_SwCluC_00208](#))

[SWS_SwCluC_02413]{DRAFT} [The `Xxx_RequestResults` function shall be named `SwCluC_DcmProxy_RequestResults_<RCSN>`, where `<RCSN>` is the `shortName` of the `SwCluCDcmProxyRoutineControl` container.]([SRS_SwCluC_00208](#))

[SWS_SwCluC_02414]{DRAFT} [The `Xxx_RequestResults` function of `Dcm Low Proxy` shall return `E_NOT_OK` and the `ErrorCode` `DCM_E_REQUESTOUTOFRANGE`, if the corresponding `routine control proxy` is not connected to an instance in the `Dcm High Proxy`.]([SRS_SwCluC_00208](#))

RequestResultsConfirmation Operation

[SWS_SwCluC_02415]{DRAFT} [The `Dcm Low Proxy` shall provide an instance of a `Xxx_RequestResultsConfirmation` function per configured `SwCluCDcmProxyRoutineControl` container in the `Dcm Low Proxy`.]([SRS_SwCluC_00208](#))

[SWS_SwCluC_02416]{DRAFT} [The `Xxx_RequestResultsConfirmation` function shall be named `SwCluC_DcmProxy_RequestResultsConfirmation_<RCSN>`, where `<RCSN>` is the `shortName` of the `SwCluCDcmProxyRoutineControl` container.]([SRS_SwCluC_00208](#))

[SWS_SwCluC_02417]{DRAFT} [The `Xxx_RequestResultsConfirmation` function of `Dcm Low Proxy` shall return `E_NOT_OK`, if the corresponding `routine control proxy` is not connected to an instance in the `Dcm High Proxy`.] ([SRS_SwCluC_00208](#))

Binary Manifest

[SWS_SwCluC_02395]{DRAFT} [The `Dcm Low Proxy` shall create for each `routine control proxy` - configured via `SwCluCdcmProxyRoutineControl` container - a required resource entry in the `Binary Manifest`.] ()

7.4.3.5.3.3 Service Request Notification proxy

Indication Operation

[SWS_SwCluC_02418]{DRAFT} [The `Dcm Low Proxy` shall provide an instance of a `Xxx_Indication` function per configured `SwCluCdcmProxyServiceRequestNotification` container in the `Dcm Low Proxy`.] ([SRS_SwCluC_00208](#))

[SWS_SwCluC_02419]{DRAFT} [The `Xxx_Indication` function shall be named `SwCluC_DcmProxy_Indication_<SRNSN>`, where `<SRNSN>` is the `short-Name` of the `SwCluCdcmProxyServiceRequestNotification` container.] ([SRS_SwCluC_00208](#))

[SWS_SwCluC_02420]{DRAFT} [The `Xxx_Indication` function of `Dcm Low Proxy` shall return `E_NOT_OK` and the `ErrorCode` `DCM_E_REQUESTOUTOFRANGE`, if the corresponding `routine control proxy` is not connected to an instance in the `Dcm High Proxy`.] ([SRS_SwCluC_00208](#))

Confirmation Operation

[SWS_SwCluC_02421]{DRAFT} [The `Dcm Low Proxy` shall provide an instance of a `Xxx_Confirmation` function per configured `SwCluCdcmProxyServiceRequestNotification` container in the `Dcm Low Proxy`.] ([SRS_SwCluC_00208](#))

[SWS_SwCluC_02422]{DRAFT} [The `Xxx_Confirmation` function shall be named `SwCluC_DcmProxy_Confirmation_<SRNSN>`, where `<SRNSN>` is the `short-Name` of the `SwCluCdcmProxyServiceRequestNotification` container.] ([SRS_SwCluC_00208](#))

[SWS_SwCluC_02423]{DRAFT} [The `Xxx_Confirmation` function of `Dcm Low Proxy` shall return `E_NOT_OK` and the `ErrorCode` `DCM_E_REQUESTOUTOFRANGE`, if the corresponding `routine control proxy` is not connected to an instance in the `Dcm High Proxy`.] ([SRS_SwCluC_00208](#))

Binary Manifest

[SWS_SwCluC_02396]{DRAFT} [The `Dcm Low Proxy` shall create for each `service request notification proxy` - configured via `SwCluCDcmProxyServiceRequestNotification` container - a required resource entry in the `Binary Manifest`.]()

7.4.3.5.3.4 Multiple Partitions

The invoked interface functions need to change the partition in the `Host Software Cluster`, before the calls are ending up in the `Application Software Cluster`, if the `Dcm` module does not offer a satellite on this partition. This partition change can be implemented in the `Low Proxy`, by means of the `SchM` or with platform proprietary callouts.

[SWS_SwCluC_02425]{DRAFT} [The `Dcm Low Proxy` shall provide, for each `SwCluCDcmProxyBaseSocket`, a `SwCluC_DcmProxy_Init` API, to initialize the `Dcm High Proxy` of an `Application Software Cluster`. This shall be one element of the service resource `SwCluCDcmProxyBaseSocket`.](*SRS_SwCluC_00208*)

[SWS_SwCluC_02424]{DRAFT} [The interface function instance for the `diagnostic data proxy`, `routine control proxy` and `service request notification proxy`, according to [SWS_SwCluC_02350], [SWS_SwCluC_02353], [SWS_SwCluC_02356], [SWS_SwCluC_02359], [SWS_SwCluC_02362], [SWS_SwCluC_02365], [SWS_SwCluC_02368], [SWS_SwCluC_02371], [SWS_SwCluC_02374], [SWS_SwCluC_02400], [SWS_SwCluC_02403], [SWS_SwCluC_02406], [SWS_SwCluC_02409], [SWS_SwCluC_02412], [SWS_SwCluC_02415], are provided either:

- at the `EcucPartition`, referenced by
 - `SwCluCDcmProxyDiagnosticData.SwCluCProxyEcucPartitionRef`
 - OR
 - `SwCluCDcmProxyRoutineControl.SwCluCProxyEcucPartitionRef`
 - OR
 - `SwCluCDcmProxyServiceRequestNotification.SwCluCProxyEcucPartitionRef`
- OR
- if a `SwCluCDcmProxyBaseSocket` is directly available, at its `EcucPartition`
- OR
- at the `EcucPartition` of the `SwCluCDcmProxyBaseSocket`, referenced by the `SwCluCDcmProxyBaseSocket` - via `SwCluCDcmProxyUsedSatelliteRef`, applicable for the `EcucPartition` requested above. In this case,

the `EcucPartition` shall be changed, before the callback in the `High Proxy` is called.

]([SRS_SwCluC_00208](#))

Binary Manifest

The implementation of the `Dcm Low Proxy` may provide some basic infrastructure for the `Dcm High Proxy` in order to be operational. Such generic infrastructure services can be linked between `Application Software Cluster` and `Host Software Cluster` by means of a `Dcm base socket`.

[[SWS_SwCluC_02397](#)]{DRAFT} [The `Dcm Low Proxy` shall create for each `SwCluC Dcm Proxy Base Socket` a provided resource entry in the `Binary Manifest`.]()

7.4.3.6 Dem Proxy

The specified `Dem Proxy` has the following underlying design principle:

In brief, the core business of `Dem` is the management of `Diagnostic Events` and the event memory, used to store failures and to capture related freeze frames with environmental data. This requires mainly interfaces to report and query status `Diagnostic Events`, as well as interfaces to read environmental data for the freeze frames. The `Dem Proxy` provides the ability implement so called diagnostic event proxies, enabling that `Diagnostic Monitors` - reporting diagnostic events - in the `Application Software Clusters` can access the `Dem` in the `Host Software Cluster`. APIs and AUTOSAR Service Interfaces that are not related to `Diagnostic Monitors` may not be supported by the `Dem Proxy`. Data relevant for freeze frames are (according diagnostic standards) are also accessible via `Dcm` by DID. Hence, the `diagnostic data proxy` functionality of the `Dcm Proxy` has to be used.

7.4.3.6.1 Enable Dem Proxy Generation

[[SWS_SwCluC_02748](#)]{DRAFT} [The `Dem High Proxy` code, and related AUTOSAR model descriptions, shall only be created, if the configuration parameter `SwCluCProxyGenerationDem` is set to `HIGH_PROXY`.]([SRS_SwCluC_00209](#), [SRS_SwCluC_00204](#))

[[SWS_SwCluC_02749](#)]{DRAFT} [The `Dem Low Proxy` code, and related AUTOSAR model descriptions, shall only be created, if the configuration parameter `SwCluCProxyGenerationDem` is set to `LOW_PROXY`.]([SRS_SwCluC_00209](#), [SRS_SwCluC_00204](#))

7.4.3.6.2 Dem High Proxy

7.4.3.6.2.1 Dem High Proxy C-API

[SWS_SwCluC_02700]{DRAFT} [The [Dem High Proxy](#) shall provide the header file [Dem.h](#).] ([SRS_SwCluC_00209](#))

[SWS_SwCluC_02701]{DRAFT} [The [Dem High Proxy](#) shall provide the symbolic name values of [DemEventIds](#) for [Diagnostic Monitors](#) in the [Application Software Cluster](#).] ([SRS_SwCluC_00209](#))

[SWS_SwCluC_02702]{DRAFT} [The [Dem High Proxy](#) shall provide the functions for [Diagnostic Monitors](#) reporting [Diagnostic Events](#)

- [Dem_ClearPrestoredFreezeFrame](#)
- [Dem_PrestoreFreezeFrame](#)
- [Dem_ResetEventDebounceStatus](#)
- [Dem_ResetEventStatus](#)
- [Dem_SetEventDisabled](#)
- [Dem_SetEventStatus](#)

in the [Application Software Cluster](#).] ([SRS_SwCluC_00209](#), [SRS_SwCluC_00202](#))

[SWS_SwCluC_02736]{DRAFT} [The [Dem High Proxy](#) shall provide the function [Dem_SetEventStatusWithMonitorData](#), for [Diagnostic Monitors](#) reporting [Diagnostic Events](#) with monitor data in the [Application Software Cluster](#).] ([SRS_SwCluC_00209](#), [SRS_SwCluC_00202](#))

[SWS_SwCluC_02739]{DRAFT} [The [Dem High Proxy](#) shall provide the function [Dem_SetWIRStatus](#), for [Diagnostic Monitors](#) reporting [Diagnostic Events](#) in the [Application Software Cluster](#).] ([SRS_SwCluC_00209](#), [SRS_SwCluC_00202](#))

[SWS_SwCluC_02703]{DRAFT} [The [Dem High Proxy](#) shall provide the functions for [Diagnostic Info](#) of [Diagnostic Events](#)

- [Dem_GetDTCOfEvent](#)
- [Dem_GetDebouncingOfEvent](#)
- [Dem_GetEventAvailable](#)
- [Dem_GetEventExtendedDataRecordEx](#)
- [Dem_GetEventFreezeFrameDataEx](#)
- [Dem_GetEventUdsStatus](#)
- [Dem_GetFaultDetectionCounter](#)

- [Dem_GetMonitorStatus](#)

in the [Application Software Cluster](#).] ([SRS_SwCluC_00209](#), [SRS_SwCluC_00201](#), [SRS_SwCluC_00202](#))

[SWS_SwCluC_02751]{DRAFT} [If development error detection is enabled for Dem High Proxy, the APIs

- [Dem_ClearPrestoredFreezeFrame](#)
- [Dem_PrestoreFreezeFrame](#)
- [Dem_ResetEventDebounceStatus](#)
- [Dem_ResetEventStatus](#)
- [Dem_SetEventDisabled](#)
- [Dem_SetEventStatus](#)
- [Dem_GetDTCOfEvent](#)
- [Dem_GetDebouncingOfEvent](#)
- [Dem_GetEventAvailable](#)
- [Dem_GetEventExtendedDataRecordEx](#)
- [Dem_GetEventFreezeFrameDataEx](#)
- [Dem_GetEventUdsStatus](#)
- [Dem_GetFaultDetectionCounter](#)
- [Dem_GetMonitorStatus](#)
- [Dem_SetEventStatusWithMonitorData](#)
- [Dem_SetWIRStatus](#)

shall report the DET error `DEM_E_UNINIT`, when Dem High Proxy is not yet initialized.] ([SRS_SwCluC_00209](#), [SRS_BSW_00369](#), [SRS_BSW_00323](#), [SRS_BSW_00350](#))

7.4.3.6.2.2 Callback Functions

[SWS_SwCluC_02704]{DRAFT} [The [Dem High Proxy](#) shall support the optional configuration of a `<Module>_DemGetFaultDetectionCounter<ForEvent>` callback, according to [\[ECUC_Dem_00630\]](#) and [\[ECUC_Dem_00631\]](#).] ([SRS_SwCluC_00209](#), [SRS_SwCluC_00202](#))

[SWS_SwCluC_02705]{DRAFT} [The [Dem High Proxy](#) shall support the optional configuration of a `<Module>_DemInitMonitorFor<EventName>` callback, according to [ECUC_Dem_00632] and [ECUC_Dem_00601].] ([SRS_SwCluC_00209](#), [SRS_SwCluC_00202](#))

[SWS_SwCluC_02706]{DRAFT} [The [Dem High Proxy](#) shall support the optional configuration of a `<Module>_DemTriggerOnMonitorStatus` callback, according to [ECUC_Dem_00936] and [ECUC_Dem_00937].] ([SRS_SwCluC_00209](#), [SRS_SwCluC_00202](#))

[SWS_SwCluC_02707]{DRAFT} [The [Dem High Proxy](#) shall support the optional configuration of a `<Module>_DemClearEventAllowed<ForCondition>` callback, according to [ECUC_Dem_00607] and [ECUC_Dem_00609].] ([SRS_SwCluC_00209](#), [SRS_SwCluC_00202](#))

[SWS_SwCluC_02737]{DRAFT} [The [Dem High Proxy](#) shall support the optional configuration of a `<Module>_DemTriggerOnEventData` callback, according to [ECUC_Dem_00606] and [ECUC_Dem_00608].] ([SRS_SwCluC_00209](#), [SRS_SwCluC_00202](#))

[SWS_SwCluC_02738]{DRAFT} [The [Dem High Proxy](#) shall support the optional configuration of a `<Module>_DemTriggerOnEventUdsStatus` callback, according to [ECUC_Dem_00628] and [ECUC_Dem_00629].] ([SRS_SwCluC_00209](#), [SRS_SwCluC_00202](#))

7.4.3.6.2.3 Service Ports

[SWS_SwCluC_02723]{DRAFT} [The [Dem High Proxy](#) shall provide the ports belonging to a specific `Diagnostic Event`

- `Event_{Name}`
- `EventStatus_{Name}`

at the partition specific Service Software Component, to which the using [SwComponentPrototype](#) is mapped.] ([SRS_SwCluC_00209](#), [SRS_SwCluC_00201](#))

[SWS_SwCluC_02724]{DRAFT} [The [Dem High Proxy](#) shall provide the `DiagnosticMonitor_MonitorData_{Name}` port for each specific `Diagnostic Event`, where `DemEventReportingType` is set to `STANDARD_REPORTING_WITH_MONITOR_DATA` at the partition specific Service Software Component, to which the using [SwComponentPrototype](#) is mapped.] ([SRS_SwCluC_00209](#), [SRS_SwCluC_00201](#))

[SWS_SwCluC_02740]{DRAFT} [The [Dem High Proxy](#) shall provide the `EventStatus_{Name}` port for each specific `Diagnostic Event` at the partition specific Service Software Component, to which the using [SwComponentPrototype](#) is mapped.] ([SRS_SwCluC_00209](#), [SRS_SwCluC_00201](#))

[SWS_SwCluC_02725]{DRAFT} [The [Dem High Proxy](#) shall provide the `CBClrEvt_{Name}` port for each specific Diagnostic Event, where `DemCallbackClearEventAllowed` is configured at the partition specific Service Software Component, to which the using [SwComponentPrototype](#) is mapped.]([SRS_SwCluC_00209](#), [SRS_SwCluC_00201](#))

[SWS_SwCluC_02726]{DRAFT} [The [Dem High Proxy](#) shall provide the `CBFaultDetectCtr_{Name}` port for each specific Diagnostic Event, where `DemCallbackGetFDC` is configured at the partition specific Service Software Component, to which the using [SwComponentPrototype](#) is mapped.]([SRS_SwCluC_00209](#), [SRS_SwCluC_00201](#))

Note: this applies only if `DemDebounceAlgorithmClass` is set to `DebounceMonitorInternal`

[SWS_SwCluC_02727]{DRAFT} [The [Dem High Proxy](#) shall provide the `CBInitEvt_{Name}` port for each specific Diagnostic Event, where `DemCallbackInitMForE` is configured at the partition specific Service Software Component, to which the using [SwComponentPrototype](#) is mapped.]([SRS_SwCluC_00209](#), [SRS_SwCluC_00201](#))

[SWS_SwCluC_02741]{DRAFT} [The [Dem High Proxy](#) shall provide the `CBDataEvt_{Name}` port for each specific Diagnostic Event, where `DemCallbackEventDataChanged` is configured at the partition specific Service Software Component, to which the using [SwComponentPrototype](#) is mapped.]([SRS_SwCluC_00209](#), [SRS_SwCluC_00201](#))

[SWS_SwCluC_02742]{DRAFT} [The [Dem High Proxy](#) shall provide the `CBEventUdsStatusChanged_{EventName}_{CallbackName}` port for each specific Diagnostic Event, where `DemCallbackEventUdsStatusChanged` is configured at the partition specific Service Software Component, to which the using [SwComponentPrototype](#) is mapped.]([SRS_SwCluC_00209](#), [SRS_SwCluC_00201](#))

[SWS_SwCluC_02743]{DRAFT} [The [Dem High Proxy](#) shall provide the `CBMonitorStatusChanged_{EventName}_{CallbackName}` port for each specific Diagnostic Event, where `DemCallbackMonitorStatusChanged` is configured at the partition specific Service Software Component, to which the using [SwComponentPrototype](#) is mapped.]([SRS_SwCluC_00209](#), [SRS_SwCluC_00201](#))

Multiple Partitions

[SWS_SwCluC_02708]{DRAFT} [The [Dem High Proxy](#) shall create one partition specific Service Software Component per configured [EcucPartition](#), with the name `Dem_{EcucPartition shortName}`.]([SRS_SwCluC_00209](#))

[SWS_SwCluC_02709]{DRAFT} [The [Dem High Proxy](#) shall provide the ports belonging to a specific interface connection at the partition specific Service Software Component, to which the using [SwComponentPrototype](#) is mapped.]([SRS_SwCluC_00209](#))

7.4.3.6.2.4 Binary Manifest

The implementation of the `Dem High Proxy` may require some basic infrastructure from the `Dem Low Proxy` in order to be operational. Such generic infrastructure services can be linked between `Application Software Cluster` and `Host Software Cluster` by means of a `Dem base socket`.

[SWS_SwCluC_02744]{DRAFT} [The `Dem High Proxy` shall create for each `SwCluCDemProxyBaseSocket` a required resource entry in the `Binary Manifest`.] (*SRS_SwCluC_00209*)

[SWS_SwCluC_02745]{DRAFT} [The `Dem High Proxy` shall create for each `diagnostic event proxy` - configured via `SwCluCDemProxyDiagnosticEvent` container - a required resource entry in the `Binary Manifest`.] (*SRS_SwCluC_00209*)

7.4.3.6.2.5 Handling of unconnected Diagnostic Events

[SWS_SwCluC_02710]{DRAFT} [In case a `Diagnostic Event` configured in the `Dem High Proxy` is not connected to any `Dem Low Proxy`, the functions / operations

- `Dem_ClearPrestoredFreezeFrame` / `ClearPrestoredFreezeFrame`
- `Dem_PrestoreFreezeFrame` / `PrestoreFreezeFrame`
- `Dem_ResetEventDebounceStatus` / `ResetEventDebounceStatus`
- `Dem_ResetEventStatus` / `ResetEventStatus`
- `Dem_SetEventDisabled` / `SetEventDisabled`
- `Dem_SetEventStatus` / `SetEventStatus`
- `Dem_SetEventStatusWithMonitorData` / `SetEventStatusWithMonitorData`
- `Dem_SetWIRStatus` / `SetWIRStatus`

of the `Dem High Proxy` shall return `E_NOT_OK`.] (*SRS_SwCluC_00209*)

[SWS_SwCluC_02711]{DRAFT} [In case a `Diagnostic Event` configured in the `Dem High Proxy` is not connected to any `Dem Low Proxy`, the `Dem High Proxy` shall return `DEM_E_NO_DTC_AVAILABLE` and the value 0 for the `DTCOfEvent` argument, when `Dem_GetDTCOfEvent` / `GetDTCOfEvent` is called.] (*SRS_SwCluC_00209*)

[SWS_SwCluC_02712]{DRAFT} [In case a `Diagnostic Event` configured in the `Dem High Proxy` is not connected to any `Dem Low Proxy`, the `Dem High Proxy` shall return `E_NOT_OK` and the value 0 for the `DebouncingState` argument, when `Dem_GetDebouncingOfEvent` / `GetDebouncingOfEvent` is called.] (*SRS_SwCluC_00209*)

[SWS_SwCluC_02713]{DRAFT} [In case a Diagnostic Event configured in the Dem High Proxy is not connected to any Dem Low Proxy, the Dem High Proxy shall return E_NOT_OK and the value FALSE for the AvailableStatus argument, when Dem_GetEventAvailable / GetEventAvailable is called.](SRS_SwCluC_00209)

[SWS_SwCluC_02714]{DRAFT} [In case a Diagnostic Event configured in the Dem High Proxy is not connected to any Dem Low Proxy, the Dem High Proxy shall return E_NOT_OK and the value 0 for the Bufsize argument, when Dem_GetEventExtendedDataRecordEx / GetEventExtendedDataRecordEx is called. The Bufsize argument stays unmodified.](SRS_SwCluC_00209)

[SWS_SwCluC_02715]{DRAFT} [In case a Diagnostic Event configured in the Dem High Proxy is not connected to any Dem Low Proxy, the Dem High Proxy shall return E_NOT_OK and the value 0 for the Bufsize argument, when Dem_GetEventFreezeFrameDataEx / GetEventFreezeFrameDataEx is called. The Bufsize argument stays unmodified.](SRS_SwCluC_00209)

[SWS_SwCluC_02716]{DRAFT} [In case a Diagnostic Event configured in the Dem High Proxy is not connected to any Dem Low Proxy, the Dem High Proxy shall return E_NOT_OK and the value 0 for the UDSStatusByte argument, when Dem_GetEventUdsStatus / GetEventUdsStatus is called.](SRS_SwCluC_00209)

[SWS_SwCluC_02717]{DRAFT} [In case a Diagnostic Event configured in the Dem High Proxy is not connected to any Dem Low Proxy, the Dem High Proxy shall return E_NOT_OK and the value 0 for the FaultDetectionCounter argument, when Dem_GetFaultDetectionCounter / GetFaultDetectionCounter is called.](SRS_SwCluC_00209)

[SWS_SwCluC_02718]{DRAFT} [In case a Diagnostic Event configured in the Dem High Proxy is not connected to any Dem Low Proxy, the Dem High Proxy shall return E_NOT_OK and the value 0 for the MonitorStatus argument, when Dem_GetMonitorStatus / GetMonitorStatus is called.](SRS_SwCluC_00209)

7.4.3.6.3 Dem Low Proxy

As shown in figure 7.10, the Dem Low Proxy shall be able to invoke APIs of the BSW modules in the Host Software Cluster, without a partition change in the Application Software Clusters. This partition change is only needed, if the BSW module does not offer a satellite on this partition. The availability of the BSW modules on dedicated EcucPartitions is a property of the Host Software Cluster.

[SWS_SwCluC_02719]{DRAFT} [The Dem Low Proxy shall provide the entry functions for Diagnostic Event reporting and info, according to [SWS_SwCluC_02702] and [SWS_SwCluC_02702], once per configured SwCluCDemProxyBaseSocket at the EcucPartition configured by SwCluCDemProxyBaseSocket.SwCluCProxyEcucPartitionRef.

In case the `SwCluCDemProxyUsedSatelliteRef` is set, the `EcucPartition` shall be changed, before the Dem API is called.]([SRS_SwCluC_00209](#))

[SWS_SwCluC_02728]{DRAFT} [The `Dem Low Proxy` shall provide, for each `SwCluCDemProxyBaseSocket`, a `SwCluC_DemProxy_Init` API, to initialize the `Dem High Proxy` of an `Application Software Cluster`. This shall be one element of the service resource `SwCluCDemProxyBaseSocket`.]([SRS_SwCluC_00209](#))

[SWS_SwCluC_02729]{DRAFT} [The `Dem Low Proxy` shall provide an instance of a `<Module>_DemGetFaultDetectionCounter<ForEvent>` per configured `Diagnostic Event` (`SwCluCDemProxyDiagnosticEvent`), in the `Dem Low Proxy`, if `DemDebounceAlgorithmClass` is set to `DebounceMonitorInternal`.]([SRS_SwCluC_00209](#))

[SWS_SwCluC_02730]{DRAFT} [The `Dem Low Proxy` shall provide an instance of a `<Module>_DemInitMonitorFor<EventName>` per configured `Diagnostic Event` (`SwCluCDemProxyDiagnosticEvent`), in the `Dem Low Proxy`.]([SRS_SwCluC_00209](#))

[SWS_SwCluC_02731]{DRAFT} [The `Dem Low Proxy` shall provide an instance of a `<Module>_DemTriggerOnMonitorStatus` per configured `Diagnostic Event` (`SwCluCDemProxyDiagnosticEvent`), in the `Dem Low Proxy`.]([SRS_SwCluC_00209](#))

[SWS_SwCluC_02732]{DRAFT} [The `Dem Low Proxy` shall provide an instance of a `<Module>_DemClearEventAllowed<ForCondition>` per configured `Diagnostic Event` (`SwCluCDemProxyDiagnosticEvent`), in the `Dem Low Proxy`.]([SRS_SwCluC_00209](#))

[SWS_SwCluC_02733]{DRAFT} [The `Dem Low Proxy` implementation shall describe the `Diagnostic Events` provided to `Dem High Proxies` via `DiagnosticEventNeeds` and `DiagnosticEventInfoNeeds`, derived from the `CpSoftwareClusterServiceResource.resourceNeeds`.]([SRS_SwCluC_00209](#))

Note: [[SWS_SwCluC_02733](#)] ensures a partly automated configuration of the `Diagnostic Event Manager`.

7.4.3.6.3.1 Binary Manifest

The implementation of the `Dem Low Proxy` may provide some basic infrastructure for the `Dem High Proxy` in order to be operational. Such generic infrastructure services can be linked between `Application Software Cluster` and `Host Software Cluster` by means of a `Dem base socket`.

[SWS_SwCluC_02746]{DRAFT} [The `Dem Low Proxy` shall create, for each `SwCluCDemProxyBaseSocket`, a provided resource entry in the `Binary Manifest`.]([SRS_SwCluC_00209](#))

[SWS_SwCluC_02747]{DRAFT} [The `Dem Low Proxy` shall create for, each `diagnostic event proxy` - configured via `SwCluCDemProxyDiagnosticEvent` container -, a provided resource entry in the `Binary Manifest`.] (SRS_SwCluC_00209)

7.4.3.6.3.2 Handling of unconnected Diagnostic Events

[SWS_SwCluC_02734]{DRAFT} [In case a `Diagnostic Event` configured in the `Dem Low Proxy` is not connected to any `Dem High Proxy`, the callback functions

- `<Module>_DemGetFaultDetectionCounter<ForEvent>`
- `<Module>_DemClearEventAllowed<ForCondition>`

of the `Dem High Proxy` shall return `E_NOT_OK`.] (SRS_SwCluC_00209)

Note: The callback functions in [SWS_SwCluC_02734] indicate that the call to the diagnostic monitor has failed, in case the `Diagnostic Event` is not connected.

[SWS_SwCluC_02735]{DRAFT} [In case a `Diagnostic Event` configured in the `Dem Low Proxy` is not connected to any `Dem High Proxy`, the callback functions

- `<Module>_DemInitMonitorFor<EventName>`
- `<Module>_DemTriggerOnMonitorStatus`

of the `Dem High Proxy` shall return `E_OK`.] (SRS_SwCluC_00209)

Note: The callback functions in [SWS_SwCluC_02735] do not support an error code different than `E_OK`.

7.4.3.7 FiM Proxy

The `FiM Proxy` provides the ability implement so called diagnostic function inhibition proxies, enabling that software in the `Application Software Clusters` can access the `FiM` in the `Host Software Cluster`, to get function permissions or to set the function availability.

The specified `FiM Proxy` has the following underlying design principle:

In the `Application Software Cluster`, `Function Inhibitions` supported by the `FiM High Proxy` are configured with `EcucModuleConfigurationValues` for a `FiM EcucModuleDef`, with according `FiMFIDs` containers. In the `Application Software Cluster` and in the `Host Software Cluster`, the configuration of `SwCluCFiMProxyFID` containers map the `FiMFIDs` to `CpSoftwareClusterServiceResources`, defining each the `globalResourceId` and the `isMandatory` attribute, relevant for the corresponding `Resource Entry` in the `Binary Manifest`.

The connection between the `FiM High Proxy` and the `FiM Low Proxy` utilizes the `Binary Manifest`. Finally, the `FiM Low Proxy` invokes the `FiM APIs` in the `Host Software Cluster` in the partitions the `FiM` module is supporting.

The configuration of the `Function Inhibition` with the relationships between diagnostic events and `FIDs` resides in the `Host Software Cluster`. To adjust the intended inhibition without rebuild of the `Host Software Cluster`, the `FiM` module provides post-build configurability to large extend.

7.4.3.7.1 Enable FiM Proxy Generation

[SWS_SwCluC_03214]{DRAFT} [The `FiM High Proxy` code, and related AUTOSAR model descriptions, shall only be created, if the configuration parameter `SwCluCProxyGenerationFiM` is set to `HIGH_PROXY`.] (*SRS_SwCluC_00210*, *SRS_SwCluC_00204*)

[SWS_SwCluC_03215]{DRAFT} [The `FiM Low Proxy` code, and related AUTOSAR model descriptions, shall only be created, if the configuration parameter `SwCluCProxyGenerationFiM` is set to `LOW_PROXY`.] (*SRS_SwCluC_00210*, *SRS_SwCluC_00204*)

7.4.3.7.2 FiM High Proxy

7.4.3.7.2.1 FiM High Proxy C-API

[SWS_SwCluC_03200]{DRAFT} [The `FiM High Proxy` shall provide the header file `FiM.h`.] (*SRS_SwCluC_00210*)

[SWS_SwCluC_03201]{DRAFT} [The `FiM High Proxy` shall provide the symbolic name values for `FiMFIDs`, for `FiM` users in the `Application Software Cluster`.] (*SRS_SwCluC_00210*)

[SWS_SwCluC_03202]{DRAFT} [The `FiM High Proxy` shall provide the functions for `Function Inhibitions`

- `FiM_GetFunctionPermission`
- `FiM_SetFunctionAvailable`

for `FiM` users in the `Application Software Cluster`.] (*SRS_SwCluC_00210*, *SRS_SwCluC_00202*)

[SWS_SwCluC_03217]{DRAFT} [If development error detection is enabled for `FiM High Proxy`, the APIs

- `FiM_GetFunctionPermission`
- `FiM_SetFunctionAvailable`

shall report the DET error `FIM_E_UNINIT`, when `FiM High Proxy` is not yet initialized.]([SRS_SwCluC_00210](#), [SRS_BSW_00369](#), [SRS_BSW_00323](#), [SRS_BSW_00350](#))

[SWS_SwCluC_03218]{DRAFT} [If development error detection is enabled for `FiM High Proxy`, the APIs

- `FiM_GetFunctionPermission`
- `FiM_SetFunctionAvailable`

shall report the DET error `FIM_E_FID_OUT_OF_RANGE`, if the functions are called with wrong `FID` value]([SRS_SwCluC_00210](#), [SRS_BSW_00369](#), [SRS_BSW_00323](#), [SRS_BSW_00350](#))

7.4.3.7.2.2 Service Ports

[SWS_SwCluC_03204]{DRAFT} [The `FiM High Proxy` shall provide the ports belonging to a specific `Function Inhibition`

- `Func_{Name}`
- `Control_{Name}`

at the partition specific Service Software Component, to which the using `SwComponentPrototype` is mapped.]([SRS_SwCluC_00210](#), [SRS_SwCluC_00201](#))

Multiple Partitions

[SWS_SwCluC_03203]{DRAFT} [The `FiM High Proxy` shall create one partition specific Service Software Component per configured `EcucPartition`, with the name `FiM_<EcucPartition shortName>`.]([SRS_SwCluC_00210](#))

7.4.3.7.2.3 Handling of unconnected Function Inhibition

[SWS_SwCluC_03205]{DRAFT} [In case a `Function Inhibition` configured in the `FiM High Proxy` is not connected to any `FiM Low Proxy`, the `FiM High Proxy` shall return `E_NOT_OK` and the value `FALSE` for the `Permission`, when `FiM_GetFunctionPermission / GetFunctionPermission` is called.]([SRS_SwCluC_00210](#))

[SWS_SwCluC_03206]{DRAFT} [In case a `Function Inhibition` configured in the `FiM High Proxy` is not connected to any `FiM Low Proxy`, the `FiM High Proxy` shall return `E_NOT_OK`, when `FiM_SetFunctionAvailable / SetFunctionAvailable` is called.]([SRS_SwCluC_00210](#))

7.4.3.7.2.4 Binary Manifest

The implementation of the [FiM High Proxy](#) may require some basic infrastructure from the [FiM Low Proxy](#) in order to be operational. Such generic infrastructure services can be linked between [Application Software Cluster](#) and [Host Software Cluster](#) by means of a [FiM base socket](#).

[SWS_SwCluC_03210]{DRAFT} [The [FiM High Proxy](#) shall create for each [SwCluCFiMProxyBaseSocket](#) a required resource entry in the [Binary Manifest](#).] ([SRS_SwCluC_00210](#))

[SWS_SwCluC_03211]{DRAFT} [The [FiM High Proxy](#) shall create for each [diagnostic function inhibition proxy - configured via SwCluCFiMProxyFID container](#) - a required resource entry in the [Binary Manifest](#).] ([SRS_SwCluC_00210](#))

7.4.3.7.3 FiM Low Proxy

As shown in figure 7.10, the [FiM Low Proxy](#) shall be able to invoke APIs of the BSW modules in the [Host Software Cluster](#), without a partition change in the [Application Software Clusters](#). This partition change is only needed, if the BSW module does not offer a satellite on this partition. The availability of the BSW modules on dedicated [EcucPartitions](#) is a property of the [Host Software Cluster](#).

[SWS_SwCluC_03207]{DRAFT} [The [FiM Low Proxy](#) implementation shall describe the [Function Inhibitions](#) provided to [FiM High Proxies](#) via [FunctionInhibitionNeeds](#), derived from the [CpSoftwareClusterServiceResource.resourceNeeds](#).] ([SRS_SwCluC_00210](#))

[SWS_SwCluC_03208]{DRAFT} [The [FiM Low Proxy](#) implementation shall describe the [control functions](#) for [Function Inhibitions](#) provided to [FiM High Proxies](#) via [FunctionInhibitionAvailabilityNeeds](#), derived from the [CpSoftwareClusterServiceResource.resourceNeeds](#).] ([SRS_SwCluC_00210](#))

Note: [[SWS_SwCluC_03205](#)] and [[SWS_SwCluC_03206](#)] ensures a partly automated configuration of the [FiM Manager](#).

[SWS_SwCluC_03209]{DRAFT} [The [FiM Low Proxy](#) shall provide, for each [SwCluCFiMProxyBaseSocket](#), a [SwCluC_FiMProxy_Init](#) API, to initialize the [FiM High Proxy](#) of an [Application Software Cluster](#). This shall be one element of the service resource [SwCluCFiMProxyBaseSocket](#).] ([SRS_SwCluC_00210](#))

7.4.3.7.3.1 Binary Manifest

The implementation of the [FiM Low Proxy](#) may provide some basic infrastructure for the [FiM High Proxy](#) in order to be operational. Such generic infrastructure services

can be linked between [Application Software Cluster](#) and [Host Software Cluster](#) by means of a [FiM base socket](#).

[SWS_SwCluC_03212]{DRAFT} [The [FiM Low Proxy](#) shall create for each [SwCluCfiMProxyBaseSocket](#) a provided resource entry in the [Binary Manifest](#).] ([SRS_SwCluC_00210](#))

[SWS_SwCluC_03213]{DRAFT} [The [FiM Low Proxy](#) shall create for each [diagnostic function inhibition proxy](#) - configured via [SwCluCfiMProxyFID](#) container - a provided resource entry in the [Binary Manifest](#).] ([SRS_SwCluC_00210](#))

7.4.4 Error Classification

7.4.4.1 Development Errors

[SWS_SwCluC_02140]{DRAFT} Development Error Types of SwCluC NvM Proxy
[The development error types defined for the SwCluC NvM Proxy are listed in table [Table 7.4](#).] ([SRS_BSW_00337](#), [SRS_BSW_00385](#), [SRS_BSW_00327](#), [SRS_BSW_00480](#), [SRS_BSW_00487](#))

<i>Type of error</i>	<i>Related error code</i>	<i>Value [hex]</i>
API service called with wrong parameter	NVM_E_PARAM_BLOCK_ID	0x0A
API is called with wrong parameter pointer	NVM_E_PARAM_POINTER	0x0F
API is called when NvM Proxy is not initialized yet	NVM_E_UNINIT	0x14

Table 7.4: Development Error Types for SwCluC NvM Proxy

[SWS_SwCluC_02650]{DRAFT} Development Error Types of SwCluC Com Proxy
[The development error types defined for the SwCluC Com Proxy are listed in table [Table 7.5](#).] ([SRS_BSW_00337](#), [SRS_BSW_00385](#), [SRS_BSW_00327](#), [SRS_BSW_00480](#), [SRS_BSW_00487](#))

<i>Type of error</i>	<i>Related error code</i>	<i>Value [hex]</i>
API service called with wrong parameter	COM_E_PARAM	0x01
API service called with a NULL pointer.	COM_E_PARAM_POINTER	0x03



△

Error code if any API service is called before the Com High Proxy module was initialized by the Com Low Proxy	COM_E_UNINIT	0x02
---	--------------	------

Table 7.5: Development Error Types for SwCluC Com Proxy

[SWS_SwCluC_02545]{DRAFT} Development Error Types of SwCluC LdCom Proxy [The development error types defined for the SwCluC LdCom Proxy are listed in table [Table 7.6.](#)] ([SRS_BSW_00337](#), [SRS_BSW_00385](#), [SRS_BSW_00327](#), [SRS_BSW_00480](#), [SRS_BSW_00487](#))

<i>Type of error</i>	<i>Related error code</i>	<i>Value [hex]</i>
Error code, if any API service is called before the LdCom High Proxy module was initialized by the LdCom Low Proxy	LDCOM_E_UNINIT	0x02
API service called with a NULL pointer. In case of this error, the API service shall return immediately without any further action, except for reporting this development error.	LDCOM_E_PARAM_POINTER	0x03
API service called with wrong Signal-ID (LdCom IPdu ID)	LDCOM_E_INVALID_SIGNAL_ID	0x05

Table 7.6: Development Error Types for SwCluC LdCom Proxy

[SWS_SwCluC_02426]{DRAFT} Development Error Types of SwCluC Dcm Proxy [The development error types defined for the SwCluC Dcm Proxy are listed in table [Table 7.7.](#)] ([SRS_BSW_00337](#), [SRS_BSW_00385](#), [SRS_BSW_00327](#), [SRS_BSW_00480](#), [SRS_BSW_00487](#))

<i>Type of error</i>	<i>Related error code</i>	<i>Value [hex]</i>
Error code, if any API service is called before the Dcm High Proxy module was initialized by the Dcm Low Proxy	DCM_E_UNINIT	0x05

Table 7.7: Development Error Types for SwCluC Dcm Proxy

[SWS_SwCluC_02750]{DRAFT} Development Error Types of SwCluC Dem Proxy [The development error types defined for the SwCluC Dem Proxy are listed in table [Table 7.8.](#)] ([SRS_BSW_00337](#), [SRS_BSW_00385](#), [SRS_BSW_00327](#), [SRS_BSW_00480](#), [SRS_BSW_00487](#))

<i>Type of error</i>	<i>Related error code</i>	<i>Value [hex]</i>
API function called with a NULL pointer.	DEM_E_PARAM_POINTER	0x11
API function called with wrong parameter value	DEM_E_PARAM_DATA	0x12
API function called with wrong length parameter value	DEM_E_PARAM_LENGTH	0x13
Error code, if any API service is called before the Dem High Proxy module was initialized by the Dem Low Proxy	DEM_E_UNINIT	0x20

Table 7.8: Development Error Types for SwCluC Dem Proxy

[SWS_SwCluC_03216]{DRAFT} Development Error Types of SwCluC FiM Proxy
 [The development error types defined for the SwCluC FiM Proxy are listed in table [Table 7.9.](#)] ([SRS_BSW_00337](#), [SRS_BSW_00385](#), [SRS_BSW_00327](#), [SRS_BSW_00480](#), [SRS_BSW_00487](#))

<i>Type of error</i>	<i>Related error code</i>	<i>Value [hex]</i>
Error code, if any API service is called before the FiM High Proxy module was initialized by the FiM Low Proxy	FIM_E_UNINIT	0x01
FiM_GetFunctionPermission or FiM_SetFunctionAvailable called with wrong FID	FIM_E_FID_OUT_OF_RANGE	0x02

Table 7.9: Development Error Types for SwCluC FiM Proxy

7.4.4.2 Runtime Errors

Runtime errors are not applicable for the [Cross Cluster Communication](#) of the [Software Cluster Connection](#).

7.4.4.3 Transient Faults

Transient Faults are not applicable for the [Cross Cluster Communication](#) of the [Software Cluster Connection](#).

7.4.4.4 Production Errors

Production Errors are not applicable for the [Cross Cluster Communication](#) of the [Software Cluster Connection](#).

7.4.4.5 Extended Production Errors

Extended Production Errors are not applicable for the [Cross Cluster Communication](#) of the [Software Cluster Connection](#).

7.5 Standardized Service Resources

This section list the standardized definitions of [CpSoftwareClusterServiceResource](#) with the defined [categorys](#) and the applicable [resourceNeeds](#).

Table 7.10 defines the meaning of the tables for [CpSoftwareClusterServiceResource](#) in this section.

Column	Description
Category	category of the CpSoftwareClusterServiceResource referencing hte related EcucContainerValues via the resourceNeeds reference.
Context and Container / Parameter	path to the standardized definition
Mult.	Describes the multiplicity, which applies for the Container, Parameter, or Reference when it is used for the description of a CpSoftwareClusterServiceResource . resourceNeeds . This multicity can deviate from the multiplicity defind for the Standardized Module Defintion
Description / Restrictions	Describes the multiplicity, which applies for the Container, Parameter, or Reference when it is used for the description of a CpSoftwareClusterServiceResource . resourceNeeds
Guard Value relevant	Defines whether and how the Container, Parameter, or Reference is treated for the calculation of the Guard Value of a Resource Entry . Following list of standard definitions apply:





	No	The Container, Parameter, or Reference is only used for information or to express a configuration request which is optionally to be fulfilled and does not impact the calculated Guard Value
	Value	The value of the Parameter is considered for the Guard Value calculation
	Choice	Applicable in case the mentioned Container is child of a choice container. The selected kind chosen Container is part of the Guard Value calculation
	from ref	Take the attributes from the referenced Container. The related Container, Parameter, or Reference will be given additionally in this table

Table 7.10: How to read Standardized Service Resource tables

7.5.1 Software Cluster Base Configuration Check

For a [CpSoftwareClusterServiceResource](#), defined for a [Software Cluster Base Configuration Check](#), [\[SWS_SwCluC_90000\]](#) applies.

[\[SWS_SwCluC_90000\]](#){DRAFT} **SWCLUSTER_RES_BASE_CNF** [

Category	SWCLUSTER_RES_BASE_CNF			
Context	Container / Parameter	Mult.	Description / Restrictions	Guard Value relevant
no standardized resourceNeeds				

Table 7.11: SWCLUSTER_RES_BASE_CNF

]()

7.5.2 Cross Cluster Communication

For a [CpSoftwareClusterServiceResource](#), defined for a [Cross Cluster Communication Base Socket](#) (see section [7.3.2.3](#)), [\[SWS_SwCluC_90008\]](#) applies.

[SWS_SwCluC_90008]{DRAFT} SWCLUSTER_RES_XCC_BASE_SOCKET [

Category	SWCLUSTER_RES_XCC_BASE_SOCKET			
Context	Container / Parameter	Mult.	Description / Restrictions	Guard Value relevant
no standardized resourceNeeds				

Table 7.12: SWCLUSTER_RES_XCC_BASE_SOCKET

]()

7.5.3 OS Proxy

For a [CpSoftwareClusterServiceResource](#), defined for a [Os Base Socket](#) (see section 7.4.3.1.3), [\[SWS_SwCluC_90002\]](#) applies.

[SWS_SwCluC_90002]{DRAFT} SWCLUSTER_RES_OS_BASE_SOCKET [

Category	SWCLUSTER_RES_OS_BASE_SOCKET			
Context	Container / Parameter	Mult.	Description / Restrictions	Guard Value relevant
no standardized resourceNeeds				

Table 7.13: SWCLUSTER_RES_OS_BASE_SOCKET

]()

For a [CpSoftwareClusterServiceResource](#), defined for a [OsApplication](#) (see section 7.4.3.1.5), [\[SWS_SwCluC_90003\]](#) applies.

[SWS_SwCluC_90003]{DRAFT} SWCLUSTER_RES_OS_APPLICATION [

Category	SWCLUSTER_RES_OS_APPLICATION			
Context	Container / Parameter	Mult.	Description / Restrictions	Guard Value relevant
no standardized resourceNeeds				

Table 7.14: SWCLUSTER_RES_OS_APPLICATION

]()

For a [CpSoftwareClusterServiceResource](#), defined for a [OsTask](#) (see section 7.4.3.1.5), [\[SWS_SwCluC_90004\]](#) applies.

[SWS_SwCluC_90004]{DRAFT} SWCLUSTER_RES_OS_TASK [

Category	SWCLUSTER_RES_OS_TASK			
Context	Container / Parameter	Mult.	Description / Restrictions	Guard Value relevant
Os/OsTask	OsTaskActivation	1		Value
Os/OsTask	OsTaskPriority	1		Value
Os/OsTask	OsTaskSchedule	1		Value

Table 7.15: SWCLUSTER_RES_OS_TASK

]()

For a [CpSoftwareClusterServiceResource](#), defined for a [OsResource](#) (see section 7.4.3.1.5), [SWS_SwCluC_90005] applies.

[SWS_SwCluC_90005]{DRAFT} SWCLUSTER_RES_OS_RESOURCE [

Category	SWCLUSTER_RES_OS_RESOURCE			
Context	Container / Parameter	Mult.	Description / Restrictions	Guard Value relevant
no standardized resourceNeeds				

Table 7.16: SWCLUSTER_RES_OS_RESOURCE

]()

For a [CpSoftwareClusterServiceResource](#), defined for a [OsSpinlock](#) (see section 7.4.3.1.5), [SWS_SwCluC_90006] applies.

[SWS_SwCluC_90006]{DRAFT} SWCLUSTER_RES_OS_SPINLOCK [

Category	SWCLUSTER_RES_OS_SPINLOCK			
Context	Container / Parameter	Mult.	Description / Restrictions	Guard Value relevant
no standardized resourceNeeds				

Table 7.17: SWCLUSTER_RES_OS_SPINLOCK

]()

For a [CpSoftwareClusterServiceResource](#), defined for a task dispatcher (see section 7.4.3.1.5), [SWS_SwCluC_90007] applies.

[SWS_SwCluC_90007]{DRAFT} SWCLUSTER_RES_OS_TASK_DISPATCHER [

Category	SWCLUSTER_RES_OS_TASK_DISPATCHER			
Context	Container / Parameter	Mult.	Description / Restrictions	Guard Value relevant
Os/OsTask	OsTaskPriority	1		Value
Os/OsTask	OsTaskSchedule	1		Value

Table 7.18: SWCLUSTER_RES_OS_TASK_DISPATCHER

]()

For a [CpSoftwareClusterServiceResource](#), defined for a function dispatcher (see section 7.4.3.1.5), [SWS_SwCluC_90008] applies.

[SWS_SwCluC_90009]{DRAFT} SWCLUSTER_RES_OS_FNC_DISPATCHER [

Category	SWCLUSTER_RES_OS_FNC_DISPATCHER			
Context	Container / Parameter	Mult.	Description / Restrictions	Guard Value relevant
no standardized resourceNeeds				

Table 7.19: SWCLUSTER_RES_OS_FNC_DISPATCHER

]()

7.5.4 NvM Proxy

For a [CpSoftwareClusterServiceResource](#), defined for a NvM Base Socket (see section 7.4.3.2.4), [SWS_SwCluC_90010] applies.

[SWS_SwCluC_90010]{DRAFT} SWCLUSTER_RES_NVM_BASE_SOCKET [

Category	SWCLUSTER_RES_NVM_BASE_SOCKET			
Context	Container / Parameter	Mult.	Description / Restrictions	Guard Value relevant
no standardized resourceNeeds				

Table 7.20: SWCLUSTER_RES_NVM_BASE_SOCKET

]()

For a [CpSoftwareClusterServiceResource](#), defined for a Nv Block (see section 7.4.3.2), [SWS_SwCluC_90001] applies.

[SWS_SwCluC_90001]{DRAFT} SWCLUSTER_RES_NV_BLOCK [

Category	SWCLUSTER_RES_NV_BLOCK			
Context	Container / Parameter	Mult.	Description / Restrictions	Guard Value relevant
NvM/NvMBlockDescriptor	NvMBlockManagementType	1		Value
NvM/NvMBlockDescriptor	NvMBlockUseAutoValidation	1		Value
NvM/NvMBlockDescriptor	NvMBlockUseCrc	1		Value
NvM/NvMBlockDescriptor	NvMBlockUseSetRamBlock Status	1		Value
NvM/NvMBlockDescriptor	NvMBlockWriteProt	1		Value
NvM/NvMBlockDescriptor	NvMCalcRamBlockCrc	1		Value
NvM/NvMBlockDescriptor	NvMResistantToChangedSw	1		Value
NvM/NvMBlockDescriptor	NvMRomBlockNum	1		Value
NvM/NvMBlockDescriptor	NvMSelectBlockForReadAll	1		Value
NvM/NvMBlockDescriptor	NvMSelectBlockForWriteAll	1		Value
NvM/NvMBlockDescriptor	NvMWriteBlockOnce	1		Value
NvM/NvMCommon	NvMSetRamBlockStatusApi	1		Value
SwCluC/SwCluCPxies/Sw CluCNvMProxy/SwCluCNv MProxyNvBlock	SwCluCNvMProxyNvBlockMax Length	1		Value

Table 7.21: SWCLUSTER_RES_NV_BLOCK

]()

7.5.5 Com Proxy

For a [CpSoftwareClusterServiceResource](#), defined for a [Com base socket](#), [SWS_SwCluC_90011] applies.

[SWS_SwCluC_90011]{DRAFT} SWCLUSTER_RES_COM_BASE_SOCKET [

Category	SWCLUSTER_RES_COM_BASE_SOCKET			
Context	Container / Parameter	Mult.	Description / Restrictions	Guard Value relevant
no standardized resourceNeeds				

Table 7.22: SWCLUSTER_RES_COM_BASE_SOCKET

]()

7.5.6 LdCom Proxy

For a [CpSoftwareClusterServiceResource](#), defined for a [LdCom base socket](#), [SWS_SwCluC_90012] applies.

[SWS_SwCluC_90012]{DRAFT} SWCLUSTER_RES_LDCOM_BASE_SOCKET [

Category	SWCLUSTER_RES_LDCOM_BASE_SOCKET			
Context	Container / Parameter	Mult.	Description / Restrictions	Guard Value relevant
no standardized resourceNeeds				

Table 7.23: SWCLUSTER_RES_LDCOM_BASE_SOCKET

]()

7.5.7 Dcm Proxy

For a [CpSoftwareClusterServiceResource](#), defined for a [Dcm base socket](#), [SWS_SwCluC_90013] applies.

[SWS_SwCluC_90013]{DRAFT} SWCLUSTER_RES_DCM_BASE_SOCKET [

Category	SWCLUSTER_RES_DCM_BASE_SOCKET			
Context	Container / Parameter	Mult.	Description / Restrictions	Guard Value relevant
no standardized resourceNeeds				

Table 7.24: SWCLUSTER_RES_DCM_BASE_SOCKET

]()

For a [CpSoftwareClusterServiceResource](#), defined for a [diagnostic data proxy](#), [SWS_SwCluC_90014] applies.

[SWS_SwCluC_90014]{DRAFT} SWCLUSTER_RES_DCM_DIAGNOSTIC_DATA [

Category	SWCLUSTER_RES_DCM_DIAGNOSTIC_DATA			
Context	Container / Parameter	Mult.	Description / Restrictions	Guard Value relevant
no standardized resourceNeeds				

Table 7.25: SWCLUSTER_RES_DCM_DIAGNOSTIC_DATA

]()

For a [CpSoftwareClusterServiceResource](#), defined for a [routine control proxy](#), [SWS_SwCluC_90015] applies.

[SWS_SwCluC_90015]{DRAFT} SWCLUSTER_RES_DCM_ROUTINE_CONTROL [

Category	SWCLUSTER_RES_DCM_ROUTINE_CONTROL			
Context	Container / Parameter	Mult.	Description / Restrictions	Guard Value relevant
no standardized resourceNeeds				

Table 7.26: SWCLUSTER_RES_DCM_ROUTINE_CONTROL

]()

For a [CpSoftwareClusterServiceResource](#), defined for a [service request notification proxy](#), [\[SWS_SwCluC_90016\]](#) applies.

[SWS_SwCluC_90016]{DRAFT} SWCLUSTER_RES_DCM_SERVICE_REQUEST_NOTIFICATION [

Category	SWCLUSTER_RES_DCM_SERVICE_REQUEST_NOTIFICATION			
Context	Container / Parameter	Mult.	Description / Restrictions	Guard Value relevant
no standardized resourceNeeds				

Table 7.27: SWCLUSTER_RES_DCM_SERVICE_REQUEST_NOTIFICATION

]()

7.5.8 Dem Proxy

For a [CpSoftwareClusterServiceResource](#), defined for a [Dem base socket](#), [\[SWS_SwCluC_90017\]](#) applies.

[SWS_SwCluC_90017]{DRAFT} SWCLUSTER_RES_DEM_BASE_SOCKET [

Category	SWCLUSTER_RES_DEM_BASE_SOCKET			
Context	Container / Parameter	Mult.	Description / Restrictions	Guard Value relevant
no standardized resourceNeeds				

Table 7.28: SWCLUSTER_RES_DEM_BASE_SOCKET

]()

For a [CpSoftwareClusterServiceResource](#), defined for a [diagnostic event proxy](#), [\[SWS_SwCluC_90018\]](#) applies.

[SWS_SwCluC_90018]{DRAFT} SWCLUSTER_RES_DEM_DIAGNOSTIC_EVENT [

Category	SWCLUSTER_RES_DEM_DIAGNOSTIC_EVENT			
Context	Container / Parameter	Mult.	Description / Restrictions	Guard Value relevant
Dem/DemConfigSet/DemEventParameter	DemDebounceAlgorithmClass	1	choice of debouncing without contained parameters	Choice
Dem/DemConfigSet/DemEventParameter	DemEventReportingType	1		Value

Table 7.29: SWCLUSTER_RES_DEM_DIAGNOSTIC_EVENT

]()

7.5.9 FiM Proxy

For a [CpSoftwareClusterServiceResource](#), defined for a [FiM base socket](#) [SWS_SwCluC_90019], applies.

[SWS_SwCluC_90019]{DRAFT} SWCLUSTER_RES_FIM_BASE_SOCKET [

Category	SWCLUSTER_RES_FIM_BASE_SOCKET			
Context	Container / Parameter	Mult.	Description / Restrictions	Guard Value relevant
no standardized resourceNeeds				

Table 7.30: SWCLUSTER_RES_FIM_BASE_SOCKET

]()

For a [CpSoftwareClusterServiceResource](#), defined for a [diagnostic function inhibition proxy](#), [SWS_SwCluC_90020] applies.

[SWS_SwCluC_90020]{DRAFT} SWCLUSTER_RES_FIM_FID [

Category	SWCLUSTER_RES_FIM_FID			
Context	Container / Parameter	Mult.	Description / Restrictions	Guard Value relevant
no standardized resourceNeeds				

Table 7.31: SWCLUSTER_RES_FIM_FID

]()

7.5.10 WdgM

For a [CpSoftwareClusterServiceResource](#) defined for a WdgM base socket [[SWS_SwCluC_90021](#)] applies.

[[SWS_SwCluC_90021](#)]{DRAFT} **SWCLUSTER_RES_WDGM_BASE_SOCKET** [

Category	SWCLUSTER_RES_WDGM_BASE_SOCKET			
Context	Container / Parameter	Mult.	Description / Restrictions	Guard Value relevant
no standardized resourceNeeds				

Table 7.32: SWCLUSTER_RES_WDGM_BASE_SOCKET

]()

Please note the definition of [WdgMBaseSocket](#) in document [20]

For a [CpSoftwareClusterServiceResource](#) defined for a cross cluster transition proxy [[SWS_SwCluC_90022](#)] applies.

[[SWS_SwCluC_90022](#)]{DRAFT} **SWCLUSTER_RES_WDGM_TRANSITION** [

Category	SWCLUSTER_RES_WDGM_TRANSITION			
Context	Container / Parameter	Mult.	Description / Restrictions	Guard Value relevant
no standardized resourceNeeds				

Table 7.33: SWCLUSTER_RES_WDGM_TRANSITION

]()

Please note the definition of [WdgMTransitionProxy](#) in document [20]

7.6 Common Functions

This section describes common functionality of the [SwCluC](#) module.

7.6.1 Version Info

[[SWS_SwCluC_09000](#)] [If a NULL pointer is passed via the parameter `versioninfo` to the function [SwCluC_GetVersionInfo](#) and development error detection is enabled for [SwCluC](#) module, the function shall report the DET error `SWCLUC_E_PARAM_POINTER`.] ([SRS_BSW_00482](#), [SRS_BSW_00373](#), [SRS_BSW_00369](#), [SRS_BSW_00323](#))

7.6.2 Error Classification

7.6.2.1 Development Errors

[SWS_SwCluC_09001] General Development Error Types of SwCluC [The general development error types defined for the `SwCluC` module are listed in table [Table 7.34.](#)] ([SRS_BSW_00337](#), [SRS_BSW_00385](#), [SRS_BSW_00327](#), [SRS_BSW_00480](#), [SRS_BSW_00487](#))

<i>Type of error</i>	<i>Related error code</i>	<i>Value [hex]</i>
Error code, if API is called with wrong parameter pointer	SWCLUC_E_PARAM_POINTER	0x01

Table 7.34: General Development Error Types of SwCluC

8 API specification

8.1 Imported types

In this chapter all types included from the following files are listed.

[SWS_SwCluC_10012] [

<i>Module</i>	<i>Header File</i>	<i>Imported Type</i>
ComStack_Types	ComStack_Types.h	BufReq_ReturnType
	ComStack_Types.h	CbkHandleIdType (draft)
	ComStack_Types.h	PduInfoType
	ComStack_Types.h	PduLengthType
	ComStack_Types.h	RetryInfoType
	ComStack_Types.h	TpDataStateType
Std	Std_Types.h	Std_ReturnType
	Std_Types.h	Std_VersionInfoType

]()

Please note that the [Software Cluster Connection](#) additionally utilizes the Platform Types (as defined in document [21]) and Standard Types (as defined in document [22]).

8.2 Type definitions

8.2.1 Binary Manifest

8.2.1.1 SwCluC_BManif_SwClusterIdType

[SWS_SwCluC_10000]{DRAFT} [

Name	SwCluC_BManif_SwClusterIdType (draft)
Kind	Type
Derived from	uint8
Description	Type of the Software Cluster's ID value Tags: atp.Status=draft
Available via	SwCluC_BManif.h

] ([SRS_SwCluC_00006](#), [SRS_BSW_00310](#))

8.2.1.2 SwCluC_BManif_MachineIdType

[SWS_SwCluC_10001]{DRAFT} [

Name	SwCluC_BManif_MachineIdType (draft)
Kind	Type
Derived from	uint8
Description	Type for the global ID value of a resource Tags: atp.Status=draft
Available via	SwCluC_BManif.h

]([SRS_SwCluC_00006](#), [SRS_BSW_00310](#))

8.2.1.3 SwCluC_BManif_ConCtrlType

[SWS_SwCluC_10002]{DRAFT} [

Name	SwCluC_BManif_ConCtrlType (draft)		
Kind	Type		
Derived from	uint16		
Range	SWCLUC_BMANIF_DISABLE_ON_ECU_CONNECTION	0x8000	The connection of Software Clusters on ECU is disabled for this machine.
Description	Type to code control flags for the connection process. Bit 0..14 are reserved. Tags: atp.Status=draft		
Available via	SwCluC_BManif.h		

]([SRS_SwCluC_00006](#), [SRS_BSW_00310](#))

8.2.1.4 SwCluC_BManif_ResourcePropertiesType

[SWS_SwCluC_10003]{DRAFT} [

Name	SwCluC_BManif_ResourcePropertiesType (draft)			
Kind	Bitfield			
Derived from	uint8			
Elements	Kind	Name	Mask	Description
	bit	SWCLUC_BMANIF_PROVIDED_RESOURCE	0x80	the resource is provided by the Software Cluster
	bit	SWCLUC_BMANIF_MANDATORY_RESOURCE	0x40	the required resource is mandatory
Description	Type to code the properties of a resource. Bit 0..5 are reserved. In case none of the bits are set the value 0 is valid. Tags: atp.Status=draft			
Available via	SwCluC_BManif.h			

]([SRS_SwCluC_00006](#), [SRS_BSW_00310](#))

8.2.1.5 SwCluC_BManif_ResourceTypeIdType

[SWS_SwCluC_10004]{DRAFT} [

Name	SwCluC_BManif_ResourceTypeIdType (draft)
Kind	Type
Derived from	uint8
Description	Type to code the type of a resource Tags: atp.Status=draft
Available via	SwCluC_BManif.h

]([SRS_SwCluC_00006](#), [SRS_BSW_00310](#))

8.2.1.6 SwCluC_BManif_GlobalResourceIdType

[SWS_SwCluC_10005]{DRAFT} [

Name	SwCluC_BManif_GlobalResourceIdType (draft)
Kind	Type
Derived from	uint32
Description	Type for the global ID value of a resource Tags: atp.Status=draft
Available via	SwCluC_BManif.h

]([SRS_SwCluC_00006](#), [SRS_BSW_00310](#))

8.2.1.7 SwCluC_BManif_ResourceGuardValueType

[SWS_SwCluC_10006]{DRAFT} [

Name	SwCluC_BManif_ResourceGuardValueType (draft)
Kind	Type
Derived from	uint32
Description	Type for the guard value of a resource Tags: atp.Status=draft
Available via	SwCluC_BManif.h

]([SRS_SwCluC_00006](#), [SRS_BSW_00310](#))

8.2.1.8 SwCluC_BManif_TableIndexType

[SWS_SwCluC_10007]{DRAFT} [

Name	SwCluC_BManif_TableIndexType (draft)
Kind	Type
Derived from	uint16
Description	Index type to address the immutable and modifiable interface table Tags: atp.Status=draft
Available via	SwCluC_BManif.h

]([SRS_SwCluC_00006](#), [SRS_BSW_00310](#))

8.2.1.9 SwCluC_BManif_HandleIndexType

[SWS_SwCluC_10008]{DRAFT} [

Name	SwCluC_BManif_HandleIndexType (draft)
Kind	Type
Derived from	uint8
Description	Index type to address a set of handles in the immutable and modifiable interface table Tags: atp.Status=draft
Available via	SwCluC_BManif.h

]([SRS_SwCluC_00006](#), [SRS_BSW_00310](#))

8.2.1.10 SwCluC_BManif_VoidFncPtrType

[SWS_SwCluC_10009]{DRAFT} [

Name	SwCluC_BManif_VoidFncPtrType (draft)
Kind	Function Pointer
Syntax	<pre>int (*SwCluC_BManif_VoidFncPtrType) (void)</pre>
Parameters (in)	None
Parameters (inout)	None
Parameters (out)	None
Return value	int -
Description	Generic function pointer type according C default type for functions Tags: atp.Status=draft
Available via	SwCluC_BManif.h

]([SRS_SwCluC_00006](#))

8.2.1.11 SwCluC_BManif_HandleType

[SWS_SwCluC_10010]{DRAFT} [

Name	SwCluC_BManif_HandleType (draft)	
Kind	Union	
Elements	dptr	
	Type	void*
	Comment	Handle as pointer to variable
	val	
	Type	uint32
	Comment	Handle as value
	fptr	
	Type	SwCluC_BManif_VoidFncPtrType
Comment	Handle as pointer to function	
Description	Type of a handle in the interface table. Tags: atp.Status=draft	
Available via	SwCluC_BManif.h	

]([SRS_SwCluC_00006](#))

8.2.1.12 SwCluC_BManif_HeaderType

[SWS_SwCluC_10011]{DRAFT} [

Name	SwCluC_BManif_HeaderType (draft)	
Kind	Structure	
Elements	Preamble	
	Type	uint64
	Comment	magic pattern of Manifest Header begin
	ManifestMajorVersion	
	Type	uint8
	Comment	version of the Binary Manifest Layout
	ManifestMinorVersion	
	Type	uint8
	Comment	version of the Binary Manifest Layout
	SwClusterId	
	Type	SwCluC_BManif_SwClusterIdType
	Comment	Software Cluster Id
	MachineId	
	Type	SwCluC_BManif_MachineIdType
	Comment	Machine Id
	SwClusterType	
Type	uint8	
Comment	kind of Software Cluster	





Reserved1	
Type	uint8
Comment	reserved
Reserved2	
Type	uint8
Comment	reserved
Reserved3	
Type	uint8
Comment	reserved
ConnectorControlFlags	
Type	SwCluC_BManif_ConCtrlType
Comment	Control flags for Software Cluster connector
NoOfInterfaceDescriptors	
Type	uint16
Comment	Number of Interface Descriptors
NoOfOfferedInterfaceHandles	
Type	uint16
Comment	Number of Handles in the Offered Interface
NoOfSubscribedInterfaceHandles	
Type	uint16
Comment	Number of Handles in the Subscribed Interface
ImmutableTablesChecksumPtr	
Type	const uint32*
Comment	Pointer to checksum about immutable descriptor and interface tables
SubscribedInterfaceValidityMarkerPtr	
Type	const uint32*
Comment	Pointer to validity marker indicating whether all subscribed tables are written
ResourcePropertiesDescriptorColumnPtr	
Type	const SwCluC_BManif_ResourcePropertiesType*
Comment	Pointer to descriptor column for resource properties
ResourceTypeDescriptorColumnPtr	
Type	const SwCluC_BManif_ResourceTypeIdType*
Comment	Pointer to descriptor column for resource type ids
GlobalResourceIdDescriptorColumnPtr	
Type	const SwCluC_BManif_GlobalResourceIdType*
Comment	Pointer to descriptor column for global resource ids
ResourceGuardValueDescriptorColumnPtr	
Type	const SwCluC_BManif_ResourceGuardValueType*
Comment	Pointer to descriptor column for guard values
OfferedInterfaceIndexDescriptorColumnPtr	
Type	const SwCluC_BManif_TableIndexType*
Comment	Pointer to descriptor column for offered interface column index
OfferedInterfaceNoOfHandlesDescriptorColumnPtr	
Type	const SwCluC_BManif_HandleIndexType*





	Comment	Pointer to descriptor column for number of handles in offered interface column
		SubscribedInterfaceIndexDescriptorColumnPtr
	Type	const SwCluC_BManif_TableIndexType*
	Comment	Pointer to descriptor column for subscribed interface column index
		SubscribedInterfaceNoOfHandlesDescriptorColumnPtr
	Type	const SwCluC_BManif_HandleIndexType*
	Comment	Pointer to descriptor column for number of handles in subscribed interface column
		SubscribedInterfaceNoOfHandleSetsDescriptorColumnPtr
	Type	const SwCluC_BManif_HandleIndexType*
	Comment	Pointer to descriptor column for number of handle sets in subscribed interface column
		OfferedInterfaceHandleColumnPtr
	Type	const SwCluC_BManif_HandleType*
	Comment	Pointer to interface column for offered handles
		SubscribedInterfaceDefaultHandleColumnPtr
	Type	const SwCluC_BManif_HandleType*
	Comment	Pointer to default interface column for subscribed handles
		SubscribedInterfaceHandleColumnPtr
	Type	const SwCluC_BManif_HandleType*
	Comment	Pointer to interface column for subscribed handles
		SubscribedInterfaceConnectedSwClusterIdColumnPtr
	Type	const SwCluC_BManif_SwClusterIdType*
	Comment	Pointer to interface column for connected cluster Id values
Description		– Tags: atp.Status=draft
Available via		SwCluC_BManif.h

|(SRS_SwCluC_00006, SRS_BSW_00310)

8.2.2 Cross Cluster Communication

The [Cross Cluster Communication](#) implements the types of a [Cross Software Cluster Communication Plug-In](#) as specified in document [4].

8.2.3 ProxyModules

The [Proxy Modules](#) partly implement the types of the according AUTOSAR BSW modules. Those are listed in appendix D.

8.3 Function definitions

8.3.1 BinaryManifest

8.3.1.1 API Principles

None of the functions defined for the `Binary Manifest` access are utilizing the `Std_ReturnType` to provide runtime errors. Since the `Binary Manifest` itself is implemented by a set of const variables, which need to be located to Flash ROM, all the failure situations caused by a temporary unavailability of the `Binary Manifest` can be excluded. Instead, it needs to be considered that the `Binary Manifest` is involved very frequently, since it is needed to access any resource from other `Software Clusters`, including the `Host Software Cluster`.

8.3.1.1.1 Named versus indexed handle access

The APIs for the `Binary Manifest` offer basically two different kinds of access.

The functions `[SWS_SwCluC_10020]`, `[SWS_SwCluC_10021]`, and `[SWS_SwCluC_10032]` provide an entire named access to the handle of a `Resource Entry` in a `Resource Entry Group`. This kind of access is useful, if the using implementation requires a named access on a specific channel. For instance the callbacks of NvM are implemented `NvBlock` specific. In such a `NvBlock` specific callback the related handles to call the `High Proxy` could be easily accessed via name.

In opposite the functions `[SWS_SwCluC_10022]`, `[SWS_SwCluC_10023]`, and `[SWS_SwCluC_10033]` provide an access to a handle of a `Resource Entry` in a `Resource Entry Group`, where the `Resource Entry` is addressed by index. This kind of access is useful, if the using implementation requires indexed based access on channels. Usually service APIs of the `High Proxies` select the channel by an ID value. E.g. the `NvBlock` gets selected by a `BlockId` parameter. Since the order of `Resource Entries` in a `Resource Entry Group` is configurable, the proxy implementation can ensure that the 'channel id' matches to the `resIndex` values. Hence, the passed 'channel id' values can be used without further conversion to get the relevant handles in the `Binary Manifest`.

8.3.1.1.2 Implementation aspects

When an implementation of the Software Cluster Connection or a CDD utilizes the `Binary Manifest`, it is not expected that the usage of the `SwCluC_BManif_GetHandle`, `SwCluC_BManif_GetConSwClusterId`, and `SwCluC_BManif_GetNoOfHandleSets` APIs result in real function calls. From the implementation perspective of the `Binary Manifest`, this should never be required, since accesses to handles or Software Cluster Ids are accesses to primitive constant variables.

[SWS_SwCluC_00057]{DRAFT} [The functions `SwCluC_BManif_GetHandle`, `SwCluC_BManif_GetConSwClusterId`, and `SwCluC_BManif_GetNoOfHandleSets`, according to [\[SWS_SwCluC_10020\]](#), [\[SWS_SwCluC_10021\]](#), [\[SWS_SwCluC_10022\]](#), [\[SWS_SwCluC_10023\]](#), [\[SWS_SwCluC_10032\]](#), and [\[SWS_SwCluC_10033\]](#), shall each be implemented as a C-function-like macro.] ([SRS_SwCluC_00012](#))

[SWS_SwCluC_00058]{DRAFT} [`<Resource Entry Group>` is the `shortName` of either the `SwCluCBManifProvideResourceEntryGroup` or `SwCluCBManifRequireResourceEntryGroup`.] ([SRS_SwCluC_00012](#))

[SWS_SwCluC_00059]{DRAFT} [`<Resource Entry>` is the `shortName` of either the `SwCluCBManifProvideResourceEntry` or `SwCluCBManifRequireResourceEntry`.] ([SRS_SwCluC_00012](#))

[SWS_SwCluC_00060]{DRAFT} [`<Handle>` is the `shortName` of either the `SwCluCBManifProvideHandle` or `SwCluCBManifNotifierHandle` of the `SwCluCBManifResourceType`, referenced by `SwCluCBManifProvideResourceEntryGroup` or `SwCluCBManifRequireResourceEntryGroup`.] ([SRS_SwCluC_00012](#))

[SWS_SwCluC_00061]{DRAFT} [`<handleType>` is either

- the referenced `ImplementationDataType`, if the `SwCluCBManifHandleImpleTypeRef` is defined for a `Provide Handle` or `Notifier Handle`. OR
- `uint32`, if the `SwCluCBManifHandleImpleTypeRef` is not defined, and `SwCluCBManifNativeHandleType` is set to `VALUE` OR
- `void *`, if the `SwCluCBManifHandleImpleTypeRef` is not defined, and `SwCluCBManifNativeHandleType` is set to `DATA_REFERENCE` OR
- `SwCluC_BManif_VoidFncPtrType`, if the `SwCluCBManifHandleImpleTypeRef` is not defined, and `SwCluCBManifNativeHandleType` is set to `FUNCTION_REFERENCE`

] ([SRS_SwCluC_00012](#))

[SWS_SwCluC_CONSTR_00091] [In a set of `SwCluCBManifProvideHandle` in a `SwCluCBManifResourceType` it is not permitted to set `SwCluCBManifIsOptional` to `false`, if any preceding `SwCluCBManifProvideHandle` has already set `SwCluCBManifIsOptional` to `true`.] ([SRS_SwCluC_00014](#))

[SWS_SwCluC_CONSTR_00092] [In a set of `SwCluCBManifNotifierHandle` in a `SwCluCBManifResourceType` it is not permitted to set `SwCluCBManifIsOptional` to `false`, if any preceding `SwCluCBManifNotifierHandle` has already set `SwCluCBManifIsOptional` to `true`.] ([SRS_SwCluC_00014](#))

Rationale: A `Resource Type` with optional handles has to define the optional ones after the non-optional ones.

[SWS_SwCluC_CONSTR_00093] [In a set of `SwCluC_BManifProvideHandle` in a `SwCluC_BManifResourceType` at most one optional handle shall exist.]([SRS_SwCluC_00014](#))

[SWS_SwCluC_CONSTR_00094] [In a set of `SwCluC_BManifNotifierHandle` in a `SwCluC_BManifResourceType` at most one optional handle shall exist.]([SRS_SwCluC_00014](#))

Rationale: If more than one optional handle exist, the mapping between the filled handles and the declared handles in the resource type becomes ambiguous. If an implementation requires to vary the number of exchanged handles on a more fine grained level, those can be put into implementation specific structure behind the optional handle. But the minor configuration with the typical highest optimization need can still work without double indirection.

8.3.1.2 SwCluC_BManif_GetHandle

[SWS_SwCluC_10020]{DRAFT} [

Service Name	SwCluC_BManif_GetHandle_<ResourceEntryGroup>_<ResourceEntry>_<Handle> (draft)	
Syntax	<handleType> SwCluC_BManif_GetHandle_<ResourceEntryGroup>_<ResourceEntry>_<Handle> (SwCluC_BManif_HandleIndexType notifierSetIndex)	
Service ID [hex]	0x10	
Sync/Async	Synchronous	
Reentrancy	Reentrant	
Parameters (in)	notifierSetIndex	Optional parameter for the notifier set index in the range 0.. SWCLUC_BMANIF_MAX_NO_OF_NOTIFIER_SETS_<Resource Entry Group>_<Resource Entry> -1 It exists if for a notifier handle of a provided resource multiple notifier sets are supported
Parameters (inout)	None	
Parameters (out)	None	
Return value	<handleType>	Pointer or value stored in Binary Manifest for this handle
Description	Returns a handle of a Resource Entry in a Resource Entry Group Tags: atp.Status=draft	
Available via	SwCluC_BManif.h	

]([SRS_SwCluC_00006](#), [SRS_BSW_00310](#))

[SWS_SwCluC_00062]{DRAFT} [The function `SwCluC_BManif_GetHandle` according to [\[SWS_SwCluC_10020\]](#) shall exist for each `SwCluC_BManifProvideHandle` and `SwCluC_BManifNotifierHandle` defined for each `SwCluC_BManifProvideResourceEntry` and `SwCluC_BManifRequireResourceEntry` in a `SwCluC_BManifProvideResourceEntryGroup` and `SwCluC_BManifRequireResourceEntryGroup`.]([SRS_SwCluC_00006](#))

8.3.1.3 SwCluC_BManif_GetHandle

[SWS_SwCluC_10022]{DRAFT} [

Service Name	SwCluC_BManif_GetHandle_<ResourceEntryGroup>_<Handle> (draft)	
Syntax	<pre><handleType> SwCluC_BManif_GetHandle_<ResourceEntryGroup>_<Handle> (SwCluC_BManif_TableIndexType resIndex, SwCluC_BManif_HandleIndexType notifierSetIndex)</pre>	
Service ID [hex]	0x11	
Sync/Async	Synchronous	
Reentrancy	Reentrant	
Parameters (in)	resIndex	Index of the resource entry in a Resource Entry Group in the range 0.. SWCLUC_BMANIF_NO_OF_ENTRIES_<Resource Entry Group> -1.
	notifierSetIndex	Optional parameter for the notifier set index in the range 0.. SWCLUC_BMANIF_MAX_NO_OF_NOTIFIER_SETS_<Resource Entry Group>_<Resource Entry> -1 It exists if for a notifier handle of a provided resource multiple notifier sets are supported
Parameters (inout)	None	
Parameters (out)	None	
Return value	<handleType>	Id of the connected Software Cluster
Description	Returns a handle of a Resource Entry in a Resource Entry Group Tags: atp.Status=draft	
Available via	SwCluC_BManif.h	

](SRS_SwCluC_00006, SRS_BSW_00310)

[SWS_SwCluC_00064]{DRAFT} [The function `SwCluC_BManif_GetHandle` according to [SWS_SwCluC_10022] shall exist for each `SwCluC_BManifProvideHandle` and `SwCluC_BManifNotifierHandle` defined for each `SwCluC_BManifProvideResourceEntryGroup` and `SwCluC_BManifRequireResourceEntryGroup`.](SRS_SwCluC_00006)

8.3.1.4 SwCluC_BManif_GetConSwClusterId

[SWS_SwCluC_10021]{DRAFT} [

Service Name	SwCluC_BManif_GetConSwClusterId_<ResourceEntryGroup>_<ResourceEntry>_<Handle> (draft)	
Syntax	<pre>SwCluC_BManif_SwClusterIdType SwCluC_BManif_GetConSwCluster Id_<ResourceEntryGroup>_<ResourceEntry>_<Handle> (SwCluC_BManif_HandleIndexType notifierSetIndex)</pre>	
Service ID [hex]	0x12	
Sync/Async	Synchronous	
Reentrancy	Reentrant	





Parameters (in)	notifierSetIndex	Optional parameter for the notifier set index in the range 0.. SWCLUC_BMANIF_MAX_NO_OF_NOTIFIER_SETS_<Resource Entry Group>_<Resource Entry> -1 It exists if for a notifier handle of a provided resource multiple notifier sets are supported
Parameters (inout)	None	
Parameters (out)	None	
Return value	SwCluC_BManif_SwClusterIdType	Id of the connected Software Cluster
Description	Returns the Id of the connected Software Cluster for a Notifier Handle of a Provide Resource Entry or a Provide Handle of a Require Resource Entry Tags: atp.Status=draft	
Available via	SwCluC_BManif.h	

](SRS_SwCluC_00006, SRS_BSW_00310, SRS_SwCluC_00008)

[SWS_SwCluC_00063]{DRAFT} [The function SwCluC_BManif_GetConSwClusterId according to [SWS_SwCluC_10021] shall exist

- for each SwCluCBManifNotifierHandle defined for each SwCluCBManifProvideResourceEntry in a SwCluCBManifProvideResourceEntryGroup

AND

- for each SwCluCBManifProvideHandle defined for each SwCluCBManifRequireResourceEntry in a SwCluCBManifRequireResourceEntryGroup.

](SRS_SwCluC_00006)

8.3.1.5 SwCluC_BManif_GetConSwClusterId

[SWS_SwCluC_10023]{DRAFT} [

Service Name	SwCluC_BManif_GetConSwClusterId_<ResourceEntryGroup>_<Handle> (draft)	
Syntax	SwCluC_BManif_SwClusterIdType SwCluC_BManif_GetConSwClusterId_<ResourceEntryGroup>_<Handle> (SwCluC_BManif_TableIndexType resIndex, SwCluC_BManif_HandleIndexType notifierSetIndex)	
Service ID [hex]	0x13	
Sync/Async	Synchronous	
Reentrancy	Reentrant	
Parameters (in)	resIndex	Index of the resource entry in a Resource Entry Group in the range 0.. SWCLUC_BMANIF_NO_OF_ENTRIES_<Resource Entry Group> -1.





	notifierSetIndex	Optional parameter for the notifier set index in the range 0.. SWCLUC_BMANIF_MAX_NO_OF_NOTIFIER_SETS_<Resource Entry Group>_<Resource Entry> -1 It exists if for a notifier handle of a provided resource multiple notifier sets are supported.
Parameters (inout)	None	
Parameters (out)	None	
Return value	SwCluC_BManif_SwClusterIdType	Id of the connected Software Cluster
Description	Returns the Id of the connected Software Cluster for a Notifier Handle of a Provide Resource Entry or a Provide Handle of a Require Resource Entry Tags: atp.Status=draft	
Available via	SwCluC_BManif.h	

](SRS_SwCluC_00006, SRS_BSW_00310, SRS_SwCluC_00008)

[SWS_SwCluC_00065]{DRAFT} [The function SwCluC_BManif_GetConSwClusterId according to [SWS_SwCluC_10023] shall exist

- for each SwCluCBManifNotifierHandle defined for a SwCluCBManifProvideResourceEntryGroup

AND

- for each SwCluCBManifProvideHandle defined for a SwCluCBManifRequireResourceEntryGroup.

](SRS_SwCluC_00006)

8.3.1.6 SwCluC_BManif_GetNoOfHandleSets

[SWS_SwCluC_10032]{DRAFT} [

Service Name	SwCluC_BManif_GetNoOfHandleSets_<Resource Entry Group>_<Resource Entry> (draft)	
Syntax	SwCluC_BManif_HandleIndexType SwCluC_BManif_GetNoOfHandleSets_<Resource Entry Group>_<Resource Entry> (void)	
Service ID [hex]	0x14	
Sync/Async	Synchronous	
Reentrancy	Reentrant	
Parameters (in)	None	
Parameters (inout)	None	
Parameters (out)	None	
Return value	SwCluC_BManif_HandleIndexType	Number of actually used - and thereby connected - handle sets
Description	Returns the number of actually used - and thereby connected - handle sets Tags: atp.Status=draft	
Available via	SwCluC_BManif.h	

](SRS_SwCluC_00006, SRS_BSW_00310)

[SWS_SwCluC_00066]{DRAFT} [The function `SwCluC_BManif_GetNoOfHandleSets` according to [SWS_SwCluC_10032] shall exist for each `SwCluCBManifProvideResourceEntry` in a `SwCluCBManifProvideResourceEntryGroup` where the parameter `SwCluCBManifMultipleNotifierSupport` is set to `MULTIPLE_NOTIFIER_SETS`.] (*SRS_SwCluC_00006*)

8.3.1.7 SwCluC_BManif_GetNoOfHandleSets

[SWS_SwCluC_10033]{DRAFT} [

Service Name	SwCluC_BManif_GetNoOfHandleSets_<Resource Entry Group> (draft)	
Syntax	<pre>SwCluC_BManif_HandleIndexType SwCluC_BManif_GetNoOfHandleSets_<Resource Entry Group> (SwCluC_BManif_TableIndexType resIndex)</pre>	
Service ID [hex]	0x15	
Sync/Async	Synchronous	
Reentrancy	Reentrant	
Parameters (in)	resIndex	Index of the resource entry in a Resource Entry Group in the range 0.. SWCLUC_BMANIF_NO_OF_ENTRIES_<Resource Entry Group> -1.
Parameters (inout)	None	
Parameters (out)	None	
Return value	SwCluC_BManif_HandleIndexType	Number of actually used - and thereby connected - handle sets
Description	Returns the number of actually used - and thereby connected - handle sets. Tags: atp.Status=draft	
Available via	SwCluC_BManif.h	

] (*SRS_SwCluC_00006, SRS_BSW_00310*)

[SWS_SwCluC_00067]{DRAFT} [The function `SwCluC_BManif_GetNoOfHandleSets` according to [SWS_SwCluC_10033] shall exist for each `SwCluCBManifProvideResourceEntryGroup` where the parameter `SwCluCBManifMultipleNotifierSupport` is set to `MULTIPLE_NOTIFIER_SETS`.] (*SRS_SwCluC_00006*)

8.3.1.8 SwCluC_BManif_GetValidityMarker

[SWS_SwCluC_10034]{DRAFT} [

Service Name	SwCluC_BManif_GetValidityMarker (draft)	
Syntax	<pre>uint32 SwCluC_BManif_GetValidityMarker (void)</pre>	
Service ID [hex]	0x16	



△

Sync/Async	Synchronous	
Reentrancy	Reentrant	
Parameters (in)	None	
Parameters (inout)	None	
Parameters (out)	None	
Return value	uint32	Value of the Subscribed Interface Validity Marker
Description	Returns the value of the Subscribed Interface Validity Marker. Tags: atp.Status=draft	
Available via	SwCluC_BManif.h	

|(SRS_SwCluC_00006, SRS_BSW_00310)

8.3.1.9 SWCLUC_BMANIF_NO_OF_ENTRIES

[SWS_SwCluC_01000]{DRAFT} [

Symbolic name: SWCLUC_BMANIF_NO_OF_ENTRIES_<Resource Entry Group>

Value: Number of [Resource Entries](#) in the according [Resource Entry Group](#)

Comments: n.a. |(SRS_SwCluC_00006, SRS_BSW_00441)

[SWS_SwCluC_00068]{DRAFT} [The definition SWCLUC_BMANIF_NO_OF_ENTRIES according to [SWS_SwCluC_01000] shall exist for each [SwCluC_BManifProvideResourceEntryGroup](#). |(SRS_SwCluC_00006)

8.3.1.10 SWCLUC_BMANIF_NO_OF_NOTIFIER_SETS

[SWS_SwCluC_01002]{DRAFT} [

Symbolic name: SWCLUC_BMANIF_MAX_NO_OF_NOTIFIER_SETS_

<Resource Entry Group>_<Resource Entry>

Value: Maximum number of notifier sets for the according [Provide Resource Entry](#)

Comments: n.a. |(SRS_SwCluC_00006, SRS_BSW_00441)

[SWS_SwCluC_00069]{DRAFT} [The definition SWCLUC_BMANIF_NO_OF_NOTIFIER_SETS according to [SWS_SwCluC_01002] shall exist for each [SwCluC_BManifProvideResourceEntry](#) in a [SwCluC_BManifProvideResourceEntryGroup](#) where the parameter [SwCluC_BManifMultipleNotifierSupport](#) is set to MULTIPLE_NOTIFIER_SETS. |(SRS_SwCluC_00006)

8.3.2 Cross Cluster Communication

In addition to the interfaces listed in this section, the [Cross Cluster Communication](#) implements the interfaces of a [Cross Software Cluster Communication Plug-In](#) as specified in document [4].

8.3.2.1 SwCluC_Xcc_Init1

[SWS_SwCluC_11000]{DRAFT} [

Service Name	SwCluC_Xcc_Init1 (draft)
Syntax	void SwCluC_Xcc_Init1 (void)
Service ID [hex]	0x20
Sync/Async	Synchronous
Reentrancy	Non Reentrant
Parameters (in)	None
Parameters (inout)	None
Parameters (out)	None
Return value	None
Description	SwCluC_Xcc_Init1 is intended to allocate and initialize system resources used by the Software Cluster Connection. It initializes interface memory which might be needed to be read by other Software Clusters but it is not allowed to do any read access to memory of any another Software Cluster. Tags: atp.Status=draft
Available via	SwCluC.h

]([SRS_SwCluC_00100](#), [SRS_SwCluC_00108](#), [SRS_BSW_00101](#), [SRS_BSW_00358](#), [SRS_BSW_00310](#))

8.3.2.2 SwCluC_Xcc_Init2

[SWS_SwCluC_11001]{DRAFT} [

Service Name	SwCluC_Xcc_Init2 (draft)
Syntax	void SwCluC_Xcc_Init2 (void)
Service ID [hex]	0x21
Sync/Async	Synchronous
Reentrancy	Non Reentrant
Parameters (in)	None
Parameters (inout)	None
Parameters (out)	None
Return value	None
Description	SwCluC_Xcc_Init2 is intended to allocate and initialize system resources used by the Software Cluster Connection. It can execute initializations which require a read access to interface memory of another Software Clusters. Tags: atp.Status=draft
Available via	SwCluC.h

]([SRS_SwCluC_00100](#), [SRS_SwCluC_00108](#), [SRS_BSW_00101](#), [SRS_BSW_00358](#), [SRS_BSW_00310](#))

8.3.3 Proxy Modules

The [Proxy Modules](#) partly implement the interfaces of the according AUTOSAR BSW modules. Those are listed in appendix [D](#).

Following functions are provided in addition:

8.3.3.1 SwCluC_OsProxy_Init

[SWS_SwCluC_12000]{DRAFT} [

Service Name	SwCluC_OsProxy_Init_<SwCluCOsProxyOsBaseSocket> (draft)
Syntax	void SwCluC_OsProxy_Init_<SwCluCOsProxyOsBaseSocket> (void)
Service ID [hex]	0x30
Sync/Async	Synchronous
Reentrancy	Non Reentrant
Parameters (in)	None
Parameters (inout)	None
Parameters (out)	None
Return value	None
Description	SwCluC_OsProxy_Init is intended to allocate and initialize system resources used by the Os Proxy linked to this specific socket Tags: atp.Status=draft
Available via	SwCluC.h

]([SRS_BSW_00101](#), [SRS_BSW_00358](#), [SRS_BSW_00310](#))

The name part <SwCluCOsProxyOsBaseSocket> is the [shortName](#) of the [SwCluCOsProxyOsBaseSocket](#).

8.3.3.2 SwCluC_NvMProxy_Init

[SWS_SwCluC_12100]{DRAFT} [

Service Name	SwCluC_NvMProxy_Init_<SwCluCNvMBaseSocket> (draft)
Syntax	void SwCluC_NvMProxy_Init_<SwCluCNvMBaseSocket> (void)
Service ID [hex]	0x31
Sync/Async	Synchronous
Reentrancy	Non Reentrant
Parameters (in)	None
Parameters (inout)	None
Parameters (out)	None





Return value	None
Description	SwCluC_NvMProxy_Init is intended to allocate and initialize system resources used by the NvMProxy linked to this specific socket. Tags: atp.Status=draft
Available via	SwCluC.h

|(SRS_BSW_00101, SRS_BSW_00358, SRS_BSW_00310)

The name part <SwCluCnVmBaseSocket> is the `shortName` of the `SwCluCnVmBaseSocket`.

8.3.3.3 SwCluC_LdComProxy_Init

[SWS_SwCluC_13000]{DRAFT} [

Service Name	SwCluC_LdComProxy_Init_<SwCluCLdComBaseSocket> (draft)
Syntax	<pre>void SwCluC_LdComProxy_Init_<SwCluCLdComBaseSocket> (void)</pre>
Service ID [hex]	0x32
Sync/Async	Synchronous
Reentrancy	Non Reentrant
Parameters (in)	None
Parameters (inout)	None
Parameters (out)	None
Return value	None
Description	SwCluC_LdComProxy_Init is intended to allocate and initialize system resources used by the LdComProxy linked to this specific socket. Tags: atp.Status=draft
Available via	SwCluC.h

|(SRS_BSW_00101, SRS_BSW_00358, SRS_BSW_00310)

The name part <SwCluCLdComProxyBaseSocket> is the `shortName` of the `SwCluCLdComProxyBaseSocket`.

8.3.3.4 SwCluC_ComProxy_Init

[SWS_SwCluC_13001]{DRAFT} [

Service Name	SwCluC_ComProxy_Init_<SwCluCComBaseSocket> (draft)
Syntax	<pre>void SwCluC_ComProxy_Init_<SwCluCComBaseSocket> (void)</pre>
Service ID [hex]	0x33





Sync/Async	Synchronous
Reentrancy	Non Reentrant
Parameters (in)	None
Parameters (inout)	None
Parameters (out)	None
Return value	None
Description	SwCluC_ComProxy_Init is intended to allocate and initialize system resources used by the ComProxy linked to this specific socket. Tags: atp.Status=draft
Available via	SwCluC.h

|(SRS_BSW_00101, SRS_BSW_00358, SRS_BSW_00310)

The name part <SwCluCComProxyBaseSocket> is the [shortName](#) of the [SwCluC-ComProxyBaseSocket](#).

8.3.3.5 SwCluC_DcmProxy_Init

[SWS_SwCluC_12200]{DRAFT} [

Service Name	SwCluC_DcmProxy_Init_<SwCluCDcmBaseSocket> (draft)
Syntax	void SwCluC_DcmProxy_Init_<SwCluCDcmBaseSocket> (void)
Service ID [hex]	0x34
Sync/Async	Synchronous
Reentrancy	Non Reentrant
Parameters (in)	None
Parameters (inout)	None
Parameters (out)	None
Return value	None
Description	SwCluC_DcmProxy_Init is intended to allocate and initialize system resources used by the Dcm Proxy linked to this specific socket. Tags: atp.Status=draft
Available via	SwCluC.h

|(SRS_BSW_00101, SRS_BSW_00358, SRS_BSW_00310)

The name part <SwCluCDcmProxyBaseSocket> is the [shortName](#) of the [SwCluCDcmProxyBaseSocket](#).

8.3.3.6 SwCluC_DemProxy_Init

[SWS_SwCluC_12300]{DRAFT} [

Service Name	SwCluC_DemProxy_Init_<SwCluCDemBaseSocket> (draft)
Syntax	void SwCluC_DemProxy_Init_<SwCluCDemBaseSocket> (void)
Service ID [hex]	0x35
Sync/Async	Synchronous
Reentrancy	Non Reentrant
Parameters (in)	None
Parameters (inout)	None
Parameters (out)	None
Return value	None
Description	SwCluC_DemProxy_Init is intended to allocate and initialize system resources used by the Dem Proxy linked to this specific socket. Tags: atp.Status=draft
Available via	SwCluC.h

]([SRS_BSW_00101](#), [SRS_BSW_00358](#), [SRS_BSW_00310](#))

The name part <SwCluCDemProxyBaseSocket> is the [shortName](#) of the [SwCluCDemProxyBaseSocket](#).

8.3.3.7 SwCluC_FiMProxy_Init

[SWS_SwCluC_12400]{DRAFT} [

Service Name	SwCluC_FiMProxy_Init_<SwCluCFiMBaseSocket> (draft)
Syntax	void SwCluC_FiMProxy_Init_<SwCluCFiMBaseSocket> (void)
Service ID [hex]	0x36
Sync/Async	Synchronous
Reentrancy	Non Reentrant
Parameters (in)	None
Parameters (inout)	None
Parameters (out)	None
Return value	None
Description	SwCluC_FiMProxy_Init is intended to allocate and initialize system resources used by the FiM Proxy linked to this specific socket. Tags: atp.Status=draft
Available via	SwCluC.h

]([SRS_BSW_00101](#), [SRS_BSW_00358](#), [SRS_BSW_00310](#))

The name part <SwCluCFiMProxyBaseSocket> is the [shortName](#) of the [SwCluC-FiMProxyBaseSocket](#).

8.3.4 Common Functions

This section describes the interfaces which are common for the whole [SwCluC](#) module.

8.3.4.1 SwCluC_GetVersionInfo

[SWS_SwCluC_91001] [

Service Name	SwCluC_GetVersionInfo	
Syntax	<pre>void SwCluC_GetVersionInfo (Std_VersionInfoType* versioninfo)</pre>	
Service ID [hex]	0x45	
Sync/Async	Asynchronous	
Reentrancy	Non Reentrant	
Parameters (in)	None	
Parameters (inout)	None	
Parameters (out)	versioninfo	Pointer to where to store the version information of this module.
Return value	None	
Description	Service to get the version information of the SwCluC module.	
Available via		

)] ([SRS_BSW_00482](#), [SRS_BSW_00373](#))

8.4 Callback notifications

This is a list of functions provided for other modules.

8.4.1 Binary Manifest

The [Binary Manifest](#) has no callback notifications.

8.4.2 Cross Cluster Communication

The [Cross Cluster Communication](#) implements the interfaces of a [Cross Software Cluster Communication Plug-In](#) as specified in document [4].

8.4.3 Proxy Modules

The [Proxy Modules](#) partly implement the callback notifications of the according AUTOSAR BSW modules. Those are listed in appendix [D](#).

8.4.3.0.1 Com Proxy

8.4.3.0.1.1 SwCluC_ComProxy_CbkRxAck

[SWS_SwCluC_13002]{DRAFT} [

Service Name	SwCluC_ComProxy_<BS>_CbkRxAck (draft)	
Syntax	void SwCluC_ComProxy_<BS>_CbkRxAck (CbkHandleIdType ComUserCbkHandleId)	
Service ID [hex]	0x37	
Sync/Async	Synchronous	
Reentrancy	Non Reentrant	
Parameters (in)	ComUserCbkHandleId	Com user callback handle Id
Parameters (inout)	None	
Parameters (out)	None	
Return value	None	
Description	This callback function indicates that the signal of the primitive data item/event is ready for reception. It is an implementation of a <ComUser_CbkRxAck> callback. Tags: atp.Status=draft	
Available via	SwCluC_ComProxy_Cbk.h	

]()

8.4.3.0.1.2 SwCluC_ComProxy_CbkInv

[SWS_SwCluC_13003]{DRAFT} [

Service Name	SwCluC_ComProxy_<BS>_CbkInv (draft)	
Syntax	void SwCluC_ComProxy_<BS>_CbkInv (CbkHandleIdType ComUserCbkHandleId)	
Service ID [hex]	0x38	
Sync/Async	Synchronous	
Reentrancy	Non Reentrant	
Parameters (in)	ComUserCbkHandleId	Com user callback handle Id
Parameters (inout)	None	
Parameters (out)	None	
Return value	None	
Description	This callback function indicates that COM has received a signal and parsed it as "invalid". It is an implementation of a <ComUser_CbkInv> callback. Tags: atp.Status=draft	
Available via	SwCluC_ComProxy_Cbk.h	

]()

8.4.3.0.1.3 SwCluC_ComProxy_CbkRxTOut

[SWS_SwCluC_13004]{DRAFT} [

Service Name	SwCluC_ComProxy_<BS>_CbkRxTOut (draft)	
Syntax	void SwCluC_ComProxy_<BS>_CbkRxTOut (CbkHandleIdType ComUserCbkHandleId)	
Service ID [hex]	0x39	
Sync/Async	Synchronous	
Reentrancy	Non Reentrant	
Parameters (in)	ComUserCbkHandleId	Com user callback handle Id
Parameters (inout)	None	
Parameters (out)	None	
Return value	None	
Description	This callback function indicates that the aliveTimeout after the last successful reception of the signal of the data item/event has expired (data element outdated). It is an implementation of a <ComUser_CbkRxTOut> callback. Tags: atp.Status=draft	
Available via	SwCluC_ComProxy_Cbk.h	

]()

8.4.3.0.1.4 SwCluC_ComProxy_CbkTxAck

[SWS_SwCluC_13005]{DRAFT} [

Service Name	SwCluC_ComProxy_<BS>_CbkTxAck (draft)	
Syntax	void SwCluC_ComProxy_<BS>_CbkTxAck (CbkHandleIdType ComUserCbkHandleId)	
Service ID [hex]	0x3a	
Sync/Async	Synchronous	
Reentrancy	Non Reentrant	
Parameters (in)	ComUserCbkHandleId	Com user callback handle Id
Parameters (inout)	None	
Parameters (out)	None	
Return value	None	
Description	This callback function indicates that the signal of the data item/event is already handed over by COM to the PDU router. It is an implementation of a <ComUser_CbkTxAck> callback. Tags: atp.Status=draft	
Available via	SwCluC_ComProxy_Cbk.h	

]()

8.4.3.0.1.5 SwCluC_ComProxy_CbkTxErr

[SWS_SwCluC_13006]{DRAFT} [

Service Name	SwCluC_ComProxy_<BS>_CbkTxErr (draft)	
Syntax	void SwCluC_ComProxy_<BS>_CbkTxErr (CbkHandleIdType ComUserCbkHandleId)	
Service ID [hex]	0x3b	
Sync/Async	Synchronous	
Reentrancy	Non Reentrant	
Parameters (in)	ComUserCbkHandleId	Com user callback handle Id
Parameters (inout)	None	
Parameters (out)	None	
Return value	None	
Description	This callback function indicates that an error occurred when the signal of the data item/event was handed over by COM to the PDU router. It is an implementation of a <ComUser_CbkTxErr> callback. Tags: atp.Status=draft	
Available via	SwCluC_ComProxy_Cbk.h	

]()

8.4.3.0.1.6 SwCluC_ComProxy_CbkTxTOut

[SWS_SwCluC_13007]{DRAFT} [

Service Name	SwCluC_ComProxy_<BS>_CbkTxTOut (draft)	
Syntax	void SwCluC_ComProxy_<BS>_CbkTxTOut (CbkHandleIdType ComUserCbkHandleId)	
Service ID [hex]	0x3c	
Sync/Async	Synchronous	
Reentrancy	Non Reentrant	
Parameters (in)	ComUserCbkHandleId	Com user callback handle Id
Parameters (inout)	None	
Parameters (out)	None	
Return value	None	
Description	This callback function indicates that the timeout of TransmissionAcknowledgementRequest for sending the signal of the data item/event has expired. It is an implementation of a <ComUser_CbkTxTOut> callback. Tags: atp.Status=draft	
Available via	SwCluC_ComProxy_Cbk.h	

]()

8.4.3.0.2 LdCom Proxy

8.4.3.0.2.1 SwCluC_LdComProxy_LdComCbkJCopyRxData

[SWS_SwCluC_13008]{DRAFT} [

Service Name	SwCluC_LdComProxy_<BS>_LdComCbkJCopyRxData (draft)	
Syntax	BufReq_ReturnType SwCluC_LdComProxy_<BS>_LdComCbkJCopyRxData (CbkHandleIdType LdComUserCbkJHandleId, const PduInfoType* info, PduLengthType* bufferSizePtr)	
Service ID [hex]	0x3d	
Sync/Async	Synchronous	
Reentrancy	Non Reentrant for same LdComUserCbkJHandleId, otherwise Reentrant	
Parameters (in)	LdComUserCbkJHandleId	LdCom user callback handle Id corresponding to the received I-PDU
	info	Provides the source buffer (SduDataPtr) and the number of bytes to be copied (SduLength). An SduLength of 0 can be used to query the current amount of available buffer in the upper layer module. In this case, the SduDataPtr may be a NULL_PTR.
Parameters (inout)	None	
Parameters (out)	bufferSizePtr	Available receive buffer after data has been copied.
Return value	BufReq_ReturnType	BUFREQ_OK: Data copied successfully BUFREQ_E_NOT_OK: Data was not copied because an error occurred.
Description	This function is called to provide the received data of an I-PDU segment (N-PDU) to the upper layer. Each call to this function provides the next part of the I-PDU data. The size of the remaining data is written to the position indicated by bufferSizePtr. Tags: atp.Status=draft	
Available via	SwCluC_LdComProxy_Cbk.h	

]()

8.4.3.0.2.2 SwCluC_LdComProxy_LdComCbkJCopyTxData

[SWS_SwCluC_13009]{DRAFT} [

Service Name	SwCluC_LdComProxy_<BS>_LdComCbkJCopyTxData (draft)	
Syntax	BufReq_ReturnType SwCluC_LdComProxy_<BS>_LdComCbkJCopyTxData (CbkHandleIdType LdComUserCbkJHandleId, const PduInfoType* info, const RetryInfoType* retry, PduLengthType* availableDataPtr)	
Service ID [hex]	0x3e	
Sync/Async	Synchronous	
Reentrancy	Non Reentrant for same LdComUserCbkJHandleId, otherwise Reentrant	
Parameters (in)	LdComUserCbkJHandleId	LdCom user callback handle Id corresponding to the transmitted I-PDU.





	info	Provides the destination buffer (SduDataPtr) and the number of bytes to be copied (SduLength). If not enough transmit data is available, no data is copied by the upper layer module and BUFREQ_E_BUSY is returned. The lower layer module may retry the call. An SduLength of 0 can be used to indicate state changes in the retry parameter or to query the current amount of available data in the upper layer module. In this case, the SduDataPtr may be a NULL_PTR.
	retry	Will not be handled by LdCom and its upper layer.
Parameters (inout)	None	
Parameters (out)	availableDataPtr	Indicates the remaining number of bytes that are available in the upper layer module's Tx buffer. availableDataPtr can be used by TP modules that support dynamic payload lengths (e.g. FrIsoTp) to determine the size of the following CFs.
Return value	BufReq_ReturnType	BUFREQ_OK: Data has been copied to the transmit buffer completely as requested. BUFREQ_E_BUSY: Request could not be fulfilled, because the required amount of Tx data is not available. The lower layer module may retry this call later on. No data has been copied. BUFREQ_E_NOT_OK: Data has not been copied. Request failed.
Description	This function is called to acquire the transmit data of an I-PDU segment (N-PDU). Each call to this function provides the next part of the I-PDU data unless retry->TpDataState is TP_DATARETRY. In this case the function restarts to copy the data beginning at the offset from the current position indicated by retry->TxTpDataCnt. The size of the remaining data is written to the position indicated by availableDataPtr Tags: atp.Status=draft	
Available via	SwCluC_LdComProxy_Cbk.h	

⌋()

8.4.3.0.2.3 SwCluC_LdComProxy_LdComCbkJxIndication

[SWS_SwCluC_13010]{DRAFT} [

Service Name	SwCluC_LdComProxy_<BS>_LdComCbkJxIndication (draft)	
Syntax	<pre>void SwCluC_LdComProxy_<BS>_LdComCbkJxIndication (CbkHandleIdType LdComUserCbkJxHandleId, const PduInfoType* PduInfoPtr)</pre>	
Service ID [hex]	0x3f	
Sync/Async	Synchronous	
Reentrancy	Non Reentrant for same LdComUserCbkJxHandleId, otherwise Reentrant	
Parameters (in)	LdComUserCbkJxHandleId	LdCom user callback handle Id corresponding to the received PDU
	PduInfoPtr	Contains the length (SduLength) of the received PDU, a pointer to a buffer (SduDataPtr) containing the PDU, and the MetaData related to this PDU.
Parameters (inout)	None	
Parameters (out)	None	
Return value	None	





Description	Indication of a received PDU from a lower layer communication interface module. Tags: atp.Status=draft
Available via	SwCluC_LdComProxy_Cbk.h

]()

8.4.3.0.2.4 SwCluC_LdComProxy_LdComCbkJStartOfReception

[SWS_SwCluC_13015]{DRAFT} [

Service Name	SwCluC_LdComProxy_<BS>_LdComCbkJStartOfReception (draft)	
Syntax	<pre>BufReq_ReturnType SwCluC_LdComProxy_<BS>_LdComCbkJStartOfReception (CbkHandleIdType LdComUserCbkJHandleId, const PduInfoType* info, PduLengthType TpSduLength, PduLengthType* bufferSizePtr)</pre>	
Service ID [hex]	0x40	
Sync/Async	Synchronous	
Reentrancy	Non Reentrant for same LdComUserCbkJHandleId, otherwise Reentrant	
Parameters (in)	LdComUserCbkJHandleId	LdCom user callback handle Id corresponding to the I-PDU.
	info	Pointer to a PduInfoType structure containing the payload data (without protocol information) and payload length of the first frame or single frame of a transport protocol I-PDU reception, and the MetaData related to this PDU. If neither first/single frame data nor MetaData are available, this parameter is set to NULL_PTR.
	TpSduLength	Total length of the N-SDU to be received.
Parameters (inout)	None	
Parameters (out)	bufferSizePtr	Available receive buffer in the receiving module. This parameter will be used to compute the Block Size (BS) in the transport protocol module.
Return value	BufReq_ReturnType	BUFREQ_OK: Connection has been accepted. bufferSizePtr indicates the available receive buffer; reception is continued. If no buffer of the requested size is available, a receive buffer size of 0 shall be indicated by bufferSizePtr. BUFREQ_E_NOT_OK: Connection has been rejected; reception is aborted. bufferSizePtr remains unchanged. BUFREQ_E_OVFL: No buffer of the required length can be provided; reception is aborted. bufferSizePtr remains unchanged.
Description	This function is called at the start of receiving an N-SDU. The N-SDU might be fragmented into multiple N-PDUs (FF with one or more following CFs) or might consist of a single N-PDU (SF). The service shall provide the currently available maximum buffer size when invoked with TpSduLength equal to 0. Tags: atp.Status=draft	
Available via	SwCluC_LdComProxy_Cbk.h	

]()

8.4.3.0.2.5 SwCluC_LdComProxy_LdComCbkJpRxIndication

[SWS_SwCluC_13011]{DRAFT} [

Service Name	SwCluC_LdComProxy_<BS>_LdComCbkJpRxIndication (draft)	
Syntax	<pre>void SwCluC_LdComProxy_<BS>_LdComCbkJpRxIndication (CbkHandleIdType LdComUserCbkJpHandleId, Std_ReturnType result)</pre>	
Service ID [hex]	0x41	
Sync/Async	Synchronous	
Reentrancy	Non Reentrant for same sn, otherwise Reentrant	
Parameters (in)	LdComUserCbkJpHandleId	LdCom user callback handle Id corresponding to the received I-PDU
	result	Result of the reception.
Parameters (inout)	None	
Parameters (out)	None	
Return value	None	
Description	<p>Called after an I-PDU has been received via the TP API, the result indicates whether the transmission was successful or not.</p> <p>Tags: atp.Status=draft</p>	
Available via	SwCluC_LdComProxy_Cbk.h	

]()

8.4.3.0.2.6 SwCluC_LdComProxy_LdComCbkJriggerTransmit

[SWS_SwCluC_13012]{DRAFT} [

Service Name	SwCluC_LdComProxy_<BS>_LdComCbkJriggerTransmit (draft)	
Syntax	<pre>Std_ReturnType SwCluC_LdComProxy_<BS>_LdComCbkJriggerTransmit (CbkHandleIdType LdComUserCbkJpHandleId, PduInfoType* PduInfoPtr)</pre>	
Service ID [hex]	0x42	
Sync/Async	Asynchronous	
Reentrancy	Non Reentrant for same LdComUserCbkJpHandleId, otherwise Reentrant	
Parameters (in)	LdComUserCbkJpHandleId	LdCom user callback handle Id corresponding to the ID of the SDU that is requested to be transmitted
	PduInfoPtr	Contains a pointer to a buffer (SduDataPtr) to where the SDU data shall be copied, and the available buffer size in SduLengh. On return, the service will indicate the length of the copied SDU data in SduLength.
Parameters (inout)	None	
Parameters (out)	None	
Return value	Std_ReturnType	<p>E_OK: SDU has been copied and SduLength indicates the number of copied bytes.</p> <p>E_NOT_OK: No SDU data has been copied. PduInfoPtr must not be used since it may contain a NULL pointer or point to invalid data.</p>





Description	<p>Within this API, the upper layer module (called module) shall check whether the available data fits into the buffer size reported by PduInfoPtr->SduLength. If it fits, it shall copy its data into the buffer provided by PduInfoPtr->SduDataPtr and update the length of the actual copied data in PduInfoPtr->SduLength. If not, it returns E_NOT_OK without changing PduInfoPtr.</p> <p>Tags: atp.Status=draft</p>
Available via	SwCluC_LdComProxy_Cbk.h

]()

8.4.3.0.2.7 SwCluC_LdComProxy_LdComCbkJxConfirmation

[SWS_SwCluC_13013]{DRAFT} [

Service Name	SwCluC_LdComProxy_<BS>_LdComCbkJxConfirmation (draft)	
Syntax	<pre>void SwCluC_LdComProxy_<BS>_LdComCbkJxConfirmation (CbkHandleIdType LdComUserCbkJxHandleId, Std_ReturnType result)</pre>	
Service ID [hex]	0x43	
Sync/Async	Synchronous	
Reentrancy	Non Reentrant for same LdComUserCbkJxHandleId, otherwise Reentrant	
Parameters (in)	LdComUserCbkJxHandleId	LdCom user callback handle Id corresponding to the PDU that has been transmitted
	result	E_OK: The PDU was transmitted. E_NOT_OK: Transmission of the PDU failed.
Parameters (inout)	None	
Parameters (out)	None	
Return value	None	
Description	<p>The lower layer communication interface module confirms the transmission of a PDU, or the failure to transmit a PDU.</p> <p>Tags: atp.Status=draft</p>	
Available via	SwCluC_LdComProxy_Cbk.h	

]()

8.4.3.0.2.8 SwCluC_LdComProxy_LdComCbkJpTxConfirmation

[SWS_SwCluC_13014]{DRAFT} [

Service Name	SwCluC_LdComProxy_<BS>_LdComCbkJpTxConfirmation (draft)	
Syntax	<pre>void SwCluC_LdComProxy_<BS>_LdComCbkJpTxConfirmation (CbkHandleIdType LdComUserCbkJpHandleId, Std_ReturnType result)</pre>	
Service ID [hex]	0x44	
Sync/Async	Synchronous	
Reentrancy	Non Reentrant for same LdComUserCbkJpHandleId, otherwise Reentrant	





Parameters (in)	LdComUserCbkJandleId	LdCom user callback handle Id corresponding to the transmitted I-PDU
	result	E_OK - transmission successful E_NOT_OK - transmission not successful
Parameters (inout)	None	
Parameters (out)	None	
Return value	None	
Description	This function is called after a Signal has been transmitted via the TP-API on its network. Tags: atp.Status=draft	
Available via	SwCluC_LdComProxy_Cbk.h	

]()

8.5 Scheduled functions

These functions are directly called by Basic Software Scheduler. The following functions shall have no return value and no parameter. All functions shall be non reentrant.

8.5.1 Binary Manifest

The [Binary Manifest](#) has no scheduled functions.

8.5.2 Cross Cluster Communication Scheduled functions

8.5.2.1 SwCluC_Xcc_MainFunction

[SWS_SwCluC_91002]{DRAFT} [

Service Name	SwCluC_Xcc_MainFunction_<suffix> (DRAFT)
Syntax	void SwCluC_Xcc_MainFunction_<suffix> (void)
Service ID [hex]	0x46
Description	This function shall perform timeout monitoring of SwCluC Xcc Tags: atp.Status=DRAFT
Available via	SwCluC.h

] ([SRS_BSW_00373](#), [SRS_BSW_00172](#))

[SWS_SwCluC_03099] [The [Cross Cluster Communication](#) of the [Software Cluster Connection](#) shall provide a [SwCluC_Xcc_MainFunction](#) per [SwCluC_Xcc_MainFunction](#) container where suffix is set to the [shortName](#) of the [SwCluC_Xcc_MainFunction](#) container.] ([SRS_SwCluC_00100](#), [SRS_SwCluC_00103](#))

Please note, beside the standardized scheduled functions, the [Cross Cluster Communications](#) is free to implement additional vendor specific ones if needed.

8.5.3 Proxy Modules Scheduled functions

The [Proxy Modules](#) have no standardized scheduled functions but are free to implement some if functionally needed.

8.6 Expected interfaces

In this chapter, all interfaces required from other modules are listed.

8.6.1 Mandatory interfaces

Note: This section defines all interfaces, which are required to fulfill the core functionality of the module.

8.6.1.1 Binary Manifest

The [Binary Manifest](#) has no mandatory interfaces.

8.6.1.2 Cross Cluster Communication

The [Cross Cluster Communication](#) has no mandatory interfaces.

8.6.1.3 Proxy Modules

The [Proxy Modules](#) partly implement the mandatory interfaces of the according AUTOSAR BSW modules. Those are listed in appendix [D](#).

8.6.2 Optional interfaces

This section defines all interfaces, which are required to fulfill an optional functionality of the module.

8.6.2.1 Binary Manifest

The [Binary Manifest](#) has no optional interfaces.

8.6.2.2 Cross Cluster Communication

The [Cross Cluster Communication](#) has no optional interfaces.

8.6.2.3 Proxy Modules

The [Proxy Modules](#) partly implement the optional interfaces of the according AUTOSAR BSW modules. Those are listed in appendix [D](#).

8.6.3 Configurable interfaces

In this section, all interfaces are listed where the target function could be configured. The target function is usually a callback function. The names of this kind of interfaces are not fixed because they are configurable.

8.6.3.1 Binary Manifest

The [Binary Manifest](#) has no configurable interfaces.

8.6.3.2 Cross Cluster Communication

The [Cross Cluster Communication](#) implements the interfaces of a [Cross Software Cluster Communication Plug-In](#) as specified in document [\[4\]](#).

8.6.3.3 Proxy Modules

The [Proxy Modules](#) partly implement the configurable interfaces of the according AUTOSAR BSW modules. Those are listed in appendix [D](#).

8.7 Service Interfaces

8.7.1 Binary Manifest

The [Binary Manifest](#) has no Service Interfaces.

8.7.2 Cross Cluster Communication

The [Cross Cluster Communication](#) has no Service Interfaces.

8.7.3 Proxy Modules

The [Proxy Modules](#) only implement Service Interfaces, which are already defined by the original AUTOSAR Service. Those are listed in appendix [E](#).

9 Sequence diagrams

No sequence diagrams are contained in this section.

10 Configuration specification

In general, this chapter defines configuration parameters and their clustering into containers. In order to support the specification Chapter 10.1 describes fundamentals. It also specifies a template (table) you shall use for the parameter specification. We intend to leave Chapter 10.1 in the specification to guarantee comprehension.

Chapter 10.2 specifies the structure (containers) and the parameters of the module `SwCluC`.

Chapter 10.3 specifies published information of the module `SwCluC`.

10.1 How to read this chapter

For details, refer to the chapter 10.1 “Introduction to configuration specification” in `SWS_BSWGeneral`.

10.2 Containers and configuration parameters

The following chapters summarize all configuration parameters. The detailed meanings of the parameters describe Chapter 7 and Chapter 8.

10.2.1 Module Configuration

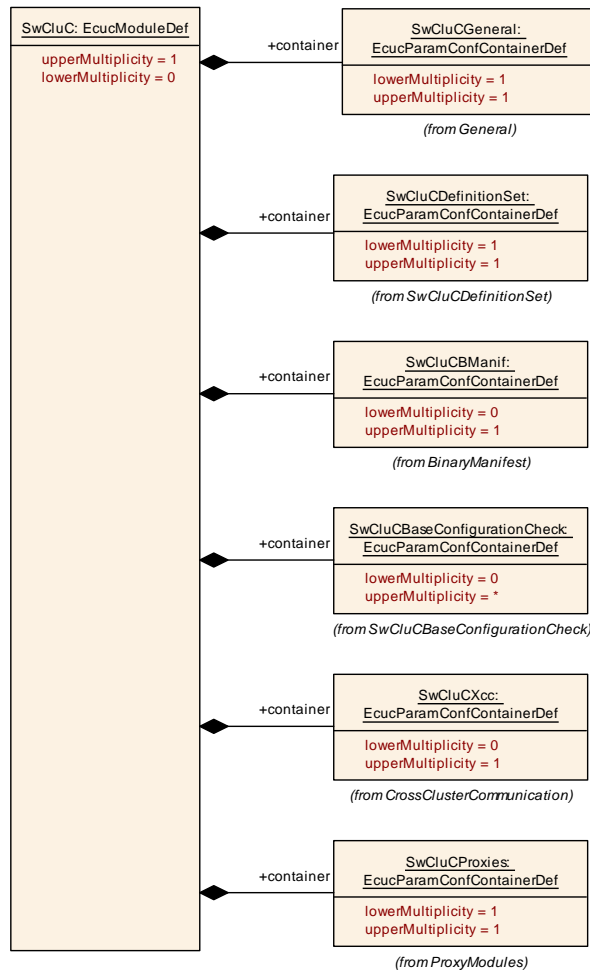

Figure 10.1: SwCluC configuration overview

SWS Item	[ECUC_SwCluC_00001]
Module Name	SwCluC
Description	Module to collect Software Cluster Connection specific configuration information.
Post-Build Variant Support	true
Supported Config Variants	VARIANT-POST-BUILD, VARIANT-PRE-COMPILE

Included Containers		
Container Name	Multiplicity	Scope / Dependency
SwCluCBManif	0..1	Configuration of the Binary Manifest of the Software Cluster Connection Tags: atp.Status=draft





Included Containers		
Container Name	Multiplicity	Scope / Dependency
SwCluCBaseConfigurationCheck	0..*	Configuration of the base configuration check of Software Cluster Connection. This configuration places a mandatory guard in the Binary Manifest where the guard value is used to proof if the general setup of the Application Software Cluster is compatible to the general setup of the Host Software Cluster. For each Application Software Cluster an individual base configuration check should be defined. Tags: atp.Status=draft
SwCluCDefinitionSet	1	Definition of a set of Software Clusters Tags: atp.Status=draft
SwCluCGeneral	1	General configuration of the Software Cluster Connection Tags: atp.Status=draft
SwCluCProxies	1	General configuration of the Proxy Modules of Software Cluster Connection Tags: atp.Status=draft
SwCluCXcc	0..1	Configuration of the Binary Manifest of the Software Cluster Connection Tags: atp.Status=draft

10.2.2 General configuration parameters

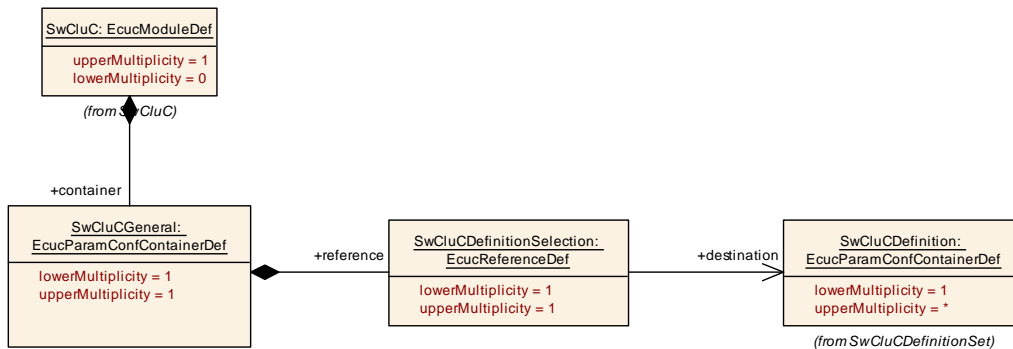

Figure 10.2: SwCluC General configuration parameters

SWS Item	[ECUC_SwCluC_00002]		
Container Name	SwCluCGeneral		
Parent Container	SwCluC		
Description	General configuration of the Software Cluster Connection Tags: atp.Status=draft		
Multiplicity Configuration Class	Pre-compile time	X	All Variants
	Link time	–	
	Post-build time	–	
Configuration Parameters			

SWS Item	[ECUC_SwCluC_00005]		
Parameter Name	SwCluCDefinitionSelection		
Parent Container	SwCluCGeneral		
Description	This reference selects the Software Cluster Definition which is applied for this Software Cluster. Tags: atp.Status=draft		
Multiplicity	1		
Type	Reference to SwCluCDefinition		
Multiplicity Configuration Class	Pre-compile time	X	All Variants
	Link time	–	
	Post-build time	–	
Value Configuration Class	Pre-compile time	X	All Variants
	Link time	–	
	Post-build time	–	
Scope / Dependency	scope: local		

No Included Containers

10.2.3 Software Cluster Definition

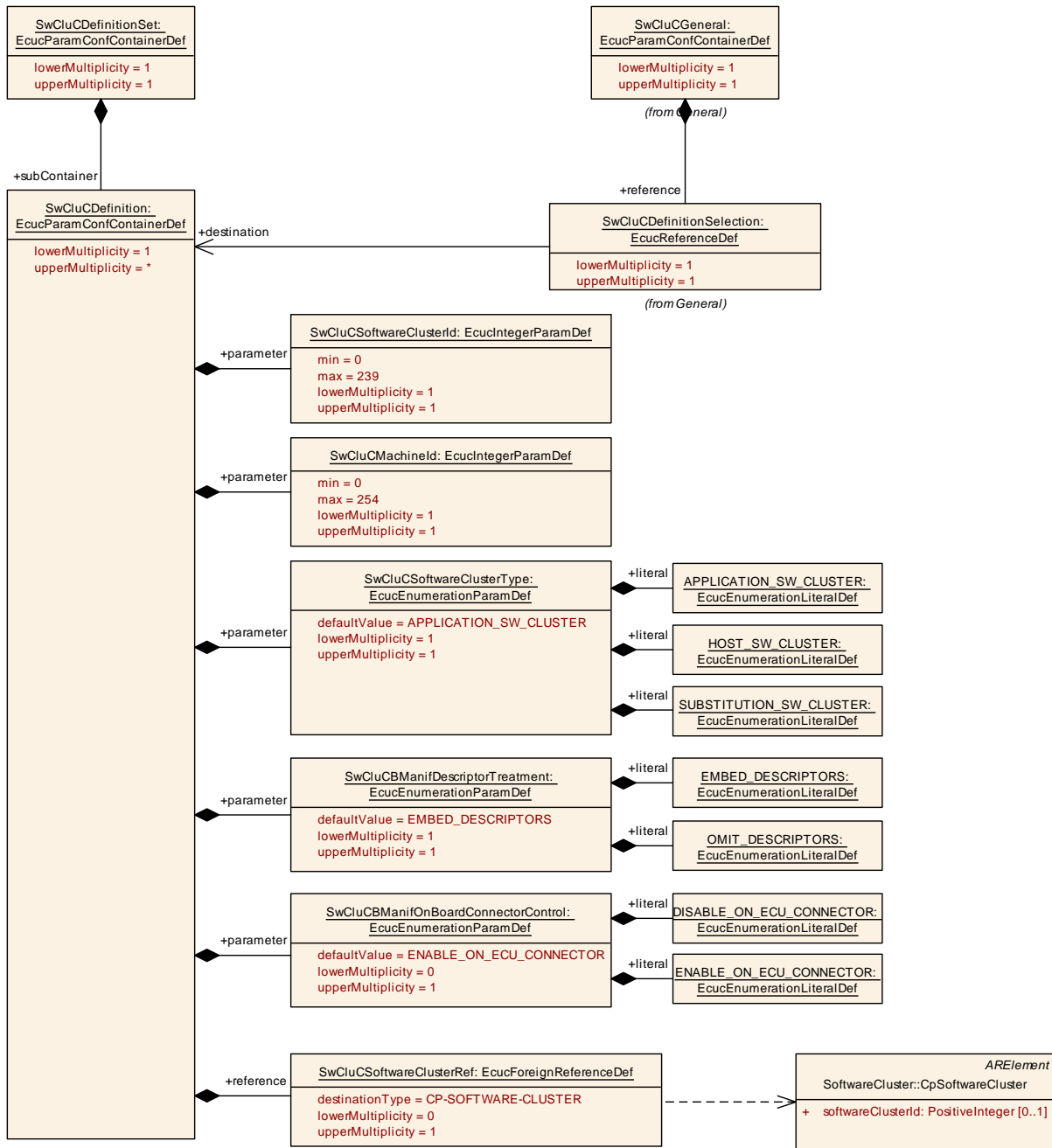

Figure 10.3: SwCluC Software Cluster Definition

SWS Item	[ECUC_SwCluC_00004]
Container Name	SwCluCDefinitionSet
Parent Container	SwCluC
Description	Definition of a set of Software Clusters Tags: atp.Status=draft
Configuration Parameters	

Included Containers		
Container Name	Multiplicity	Scope / Dependency
SwCluCDefinition	1..*	Definition of the general properties of the Software Cluster. The definitions are separated in a set of definitions in order to enable an holistic view about all existing Software Cluster Definitions. Tags: atp.Status=draft

SWS Item	[ECUC_SwCluC_00006]		
Container Name	SwCluCDefinition		
Parent Container	SwCluCDefinitionSet		
Description	Definition of the general properties of the Software Cluster. The definitions are separated in a set of definitions in order to enable an holistic view about all existing Software Cluster Definitions. Tags: atp.Status=draft		
Multiplicity Configuration Class	Pre-compile time	X	All Variants
	Link time	–	
	Post-build time	–	
Configuration Parameters			

SWS Item	[ECUC_SwCluC_00010]		
Parameter Name	SwCluCBManifDescriptorTreatment		
Parent Container	SwCluCDefinition		
Description	Configures the existence of the Interface Descriptor Table in the Binary Object of the Software Cluster. Tags: atp.Status=draft		
Multiplicity	1		
Type	EcucEnumerationParamDef		
Range	EMBED_DESCRIPTOR	The Interface Descriptor Table of the Binary Manifest is embed into the Binary Object. Tags: atp.Status=draft	
	OMIT_DESCRIPTOR	The Interface Descriptor Table of the Binary Manifest is omitted from the Binary Object. The information needs to be delivered as CpSoftware ClusterBinaryManifestDescriptor. Tags: atp.Status=draft	
Default value	EMBED_DESCRIPTOR		
Multiplicity Configuration Class	Pre-compile time	X	All Variants
	Link time	–	
	Post-build time	–	
Value Configuration Class	Pre-compile time	X	All Variants
	Link time	–	
	Post-build time	–	
Scope / Dependency	scope: ECU		

SWS Item	[ECUC_SwCluC_00011]		
Parameter Name	SwCluCBManifOnBoardConnectorControl		
Parent Container	SwCluCDefinition		





Description	SwCluCManifOnBoardConnectorControl enables or disables the onECU execution of the Software Cluster Connector. This setting is only applicable for the Host Software Cluster. Tags: atp.Status=draft		
Multiplicity	0..1		
Type	EcucEnumerationParamDef		
Range	DISABLE_ON_ECU_CONNECTOR	The connection of Software Clusters OnECU is disabled for this machine. Tags: atp.Status=draft	
	ENABLE_ON_ECU_CONNECTOR	The connection of Software Clusters OnECU is enabled for this machine. Tags: atp.Status=draft	
Default value	ENABLE_ON_ECU_CONNECTOR		
Multiplicity Configuration Class	Pre-compile time	X	All Variants
	Link time	–	
	Post-build time	–	
Value Configuration Class	Pre-compile time	X	All Variants
	Link time	–	
	Post-build time	–	
Scope / Dependency	scope: ECU		

SWS Item	[ECUC_SwCluC_00008]		
Parameter Name	SwCluCMachineId		
Parent Container	SwCluCDefinition		
Description	Unique number of the (virtual or physical) machine to which the Software Cluster belongs. Tags: atp.Status=draft		
Multiplicity	1		
Type	EcucIntegerParamDef		
Range	0 .. 254		
Default value	–		
Multiplicity Configuration Class	Pre-compile time	X	All Variants
	Link time	–	
	Post-build time	–	
Value Configuration Class	Pre-compile time	X	All Variants
	Link time	–	
	Post-build time	–	
Scope / Dependency	scope: ECU		

SWS Item	[ECUC_SwCluC_00007]		
Parameter Name	SwCluCSoftwareClusterId		
Parent Container	SwCluCDefinition		
Description	Unique number of the Software Cluster Numbers >= 0xFE are reserved to indicate special values or the unconnected state. Tags: atp.Status=draft		
Multiplicity	1		
Type	EcucIntegerParamDef		





Range	0 .. 239		
Default value	–		
Multiplicity Configuration Class	Pre-compile time	X	All Variants
	Link time	–	
	Post-build time	–	
Value Configuration Class	Pre-compile time	X	All Variants
	Link time	–	
	Post-build time	–	
Scope / Dependency	scope: ECU		

SWS Item	[ECUC_SwCluC_00009]		
Parameter Name	SwCluCSoftwareClusterType		
Parent Container	SwCluCDefinition		
Description	The type of the Software Cluster Tags: atp.Status=draft		
Multiplicity	1		
Type	EcucEnumerationParamDef		
Range	APPLICATION_SW_CLUSTER	This Software Cluster is an Application Software Cluster. Tags: atp.Status=draft	
	HOST_SW_CLUSTER	This Software Cluster is a Host Software Cluster. Tags: atp.Status=draft	
	SUBSTITUTION_SW_CLUSTER	This Software Cluster is a Substitution Software Cluster. Tags: atp.Status=draft	
Default value	APPLICATION_SW_CLUSTER		
Multiplicity Configuration Class	Pre-compile time	X	All Variants
	Link time	–	
	Post-build time	–	
Value Configuration Class	Pre-compile time	X	All Variants
	Link time	–	
	Post-build time	–	
Scope / Dependency	scope: ECU		

SWS Item	[ECUC_SwCluC_00034]		
Parameter Name	SwCluCSoftwareClusterRef		
Parent Container	SwCluCDefinition		
Description	Reference to the CpSoftwareCluster to define the link to the Software Cluster description in the System. Tags: atp.Status=draft		
Multiplicity	0..1		
Type	Foreign reference to CP-SOFTWARE-CLUSTER		
Multiplicity Configuration Class	Pre-compile time	X	All Variants
	Link time	–	
	Post-build time	–	
Value Configuration Class	Pre-compile time	X	All Variants
	Link time	–	





	Post-build time	-	
Scope / Dependency	scope: ECU		

No Included Containers

[SWS_SwCluC_CONSTR_00096] SwCluCSoftwareClusterId shall be set according CpSoftwareCluster.softwareClusterId [For a specific SwCluCDefinition, the value of SwCluCDefinition.SwCluCSoftwareClusterId shall be identical to the value of the softwareClusterId of the CpSoftwareCluster referenced via SwCluCDefinition.SwCluCSoftwareClusterRef.]()

Rationale: The SwCluCSoftwareClusterId cannot be chosen by the ECU integrator, if the softwareClusterId is already given by a system description. For integration specific software clusters, the ECU integrator has to choose a free number for the SwCluCSoftwareClusterId.

10.2.4 Software Cluster Base Configuration Check

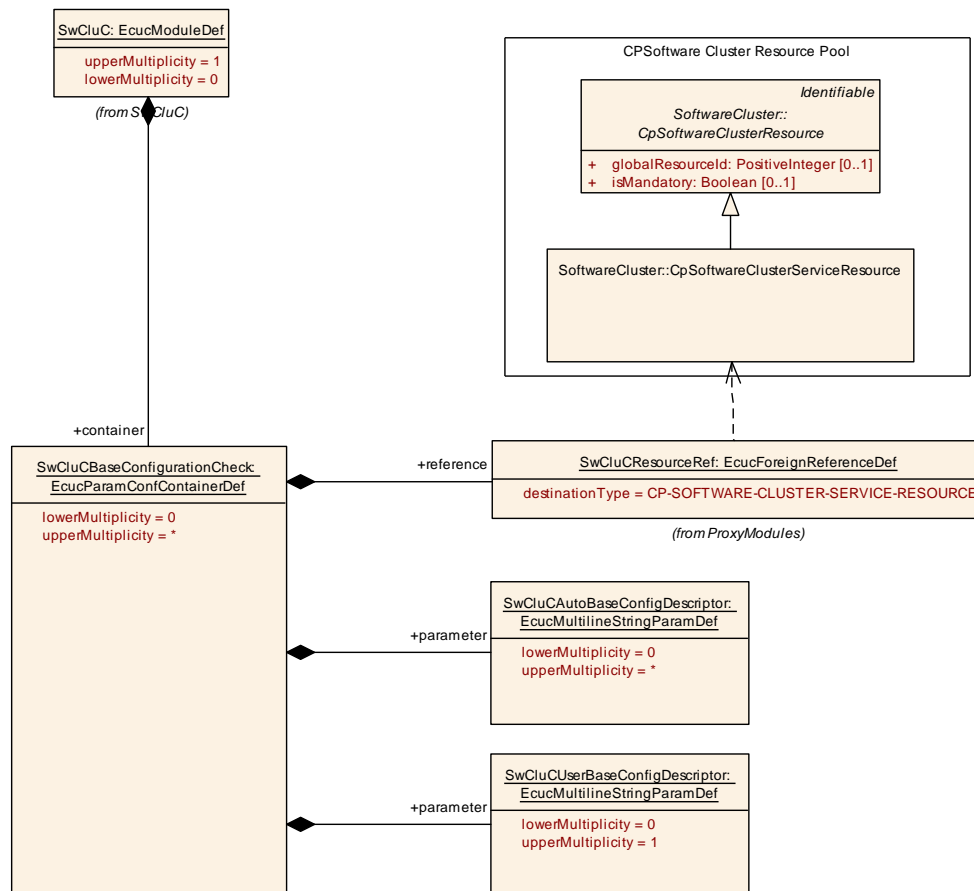

Figure 10.4: Software Cluster Base Configuration Check

SWS Item	[ECUC_SwCluC_00079]		
Container Name	SwCluCBaseConfigurationCheck		
Parent Container	SwCluC		
Description	<p>Configuration of the base configuration check of Software Cluster Connection. This configuration places a mandatory entry in the Binary Manifest where the guard value is used to proof if the general setup of the Application Software Cluster is compatible to the general setup of the Host Software Cluster. For each Application Software Cluster an individual base configuration check should be defined.</p> <p>Tags: atp.Status=draft</p>		
Multiplicity Configuration Class	Pre-compile time	X	All Variants
	Link time	–	
	Post-build time	–	
Configuration Parameters			

SWS Item	[ECUC_SwCluC_00080]		
Parameter Name	SwCluCAutoBaseConfigDescriptor		
Parent Container	SwCluCBaseConfigurationCheck		
Description	<p>A machine determined string which represent the basic configuration assumption. Multiple SwCluCAutoBaseConfigDescriptor values can be added to support that different tools contribute to the checksum. For instance Software Cluster Connection Tool, Compiler, Link, or Locate tooling. isAuto shall be set to true since tool chain adds its collected values automatically.</p> <p>Tags: atp.Status=draft</p>		
Multiplicity	0..*		
Type	EcucMultilineStringParamDef		
Default value	–		
Regular Expression	–		
Multiplicity Configuration Class	Pre-compile time	X	All Variants
	Link time	–	
	Post-build time	–	
Value Configuration Class	Pre-compile time	X	All Variants
	Link time	–	
	Post-build time	–	
Scope / Dependency	scope: ECU		

SWS Item	[ECUC_SwCluC_00081]		
Parameter Name	SwCluCUserBaseConfigDescriptor		
Parent Container	SwCluCBaseConfigurationCheck		
Description	<p>A user determined string which represent the basic configuration assumption.</p> <p>Tags: atp.Status=draft</p>		
Multiplicity	0..1		
Type	EcucMultilineStringParamDef		
Default value	–		
Regular Expression	–		
Multiplicity Configuration Class	Pre-compile time	X	All Variants
	Link time	–	
	Post-build time	–	
Value Configuration Class	Pre-compile time	X	All Variants
	Link time	–	





	Post-build time	-	
Scope / Dependency	scope: ECU		

SWS Item	[ECUC_SwCluC_00093]
Parameter Name	SwCluCResourceRef
Parent Container	SwCluCBaseConfigurationCheck
Description	Reference to the CpSoftwareClusterServiceResource. Tags: atp.Status=draft
Multiplicity	1
Type	Foreign reference to CP-SOFTWARE-CLUSTER-SERVICE-RESOURCE
Scope / Dependency	scope: ECU

No Included Containers

[SWS_SwCluC_CONSTR_00078]{DRAFT} [SwCluCBaseConfigurationCheck](#) relates only to a [CpSoftwareClusterServiceResource](#) of category [SWCLUSTER_RES_BASE_CNF](#) [The [SwCluCBaseConfigurationCheck.SwCluCResourceRef](#) shall only reference a [CpSoftwareClusterServiceResource](#) of category [SWCLUSTER_RES_BASE_CNF](#).]()

10.2.5 Binary Manifest

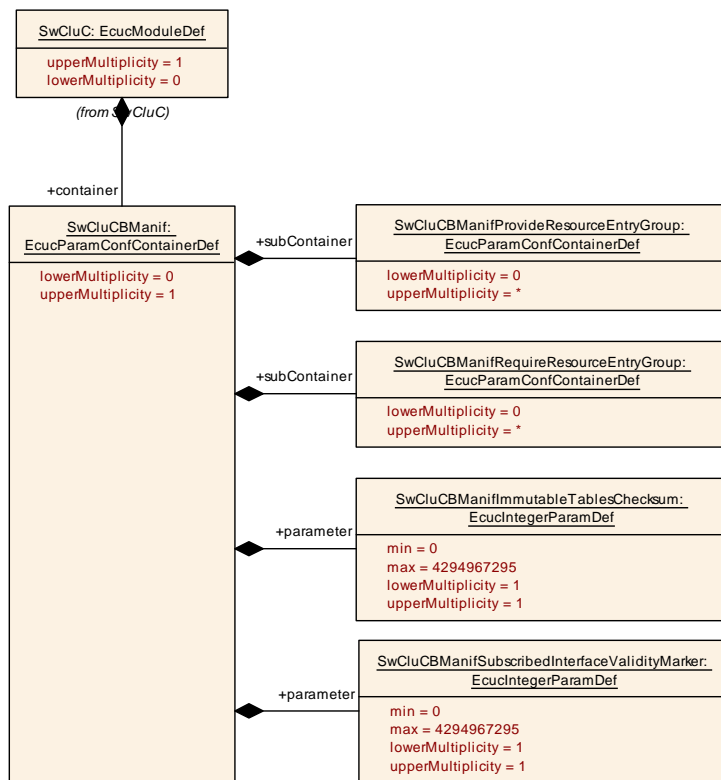

Figure 10.5: SwCluC Binary Manifest

SWS Item	[ECUC_SwCluC_00003]
Container Name	SwCluCManifest
Parent Container	SwCluC
Description	Configuration of the Binary Manifest of the Software Cluster Connection Tags: atp.Status=draft
Configuration Parameters	

SWS Item	[ECUC_SwCluC_00020]		
Parameter Name	SwCluCManifestImmutableTablesChecksum		
Parent Container	SwCluCManifest		
Description	This parameter defines the initialization value of the Immutable Tables Checksum. If the Binary Manifest code generator already calculates the checksum, the value can be stored here (withAuto == true). Tags: atp.Status=draft		
Multiplicity	1		
Type	EcucIntegerParamDef		
Range	0 .. 4294967295		
Default value	-		
Multiplicity Configuration Class	Pre-compile time	X	All Variants
	Link time	-	
	Post-build time	-	
Value Configuration Class	Pre-compile time	X	All Variants
	Link time	-	
	Post-build time	-	
Scope / Dependency	scope: ECU		

SWS Item	[ECUC_SwCluC_00022]		
Parameter Name	SwCluCManifestSubscribedInterfaceValidityMarker		
Parent Container	SwCluCManifest		
Description	This parameter defines the initialization value of the Subscribed Interface Validity Marker. The init value should be set to the erased value of the flash memory. Tags: atp.Status=draft		
Multiplicity	1		
Type	EcucIntegerParamDef		
Range	0 .. 4294967295		
Default value	-		
Multiplicity Configuration Class	Pre-compile time	X	All Variants
	Link time	-	
	Post-build time	-	
Value Configuration Class	Pre-compile time	X	All Variants
	Link time	-	
	Post-build time	-	
Scope / Dependency	scope: ECU		

Included Containers		
Container Name	Multiplicity	Scope / Dependency
SwCluCBManifProvideResourceEntryGroup	0..*	Describes a group of provided resources in the Binary Manifest. The belonging handles are put into the Binary Manifest's tables into an consecutive order which supports an array based access. Tags: atp.Status=draft
SwCluCBManifRequireResourceEntryGroup	0..*	Describes a group of required resources in the Binary Manifest. The belonging handles are put into the Binary Manifest's tables into an consecutive order which supports an array based access. Tags: atp.Status=draft
SwCluCBManifResourceType	0..*	This container defines the structure of a resource type in the Binary Manifest. Tags: atp.Status=draft

10.2.5.1 Provide Resource Entry Group

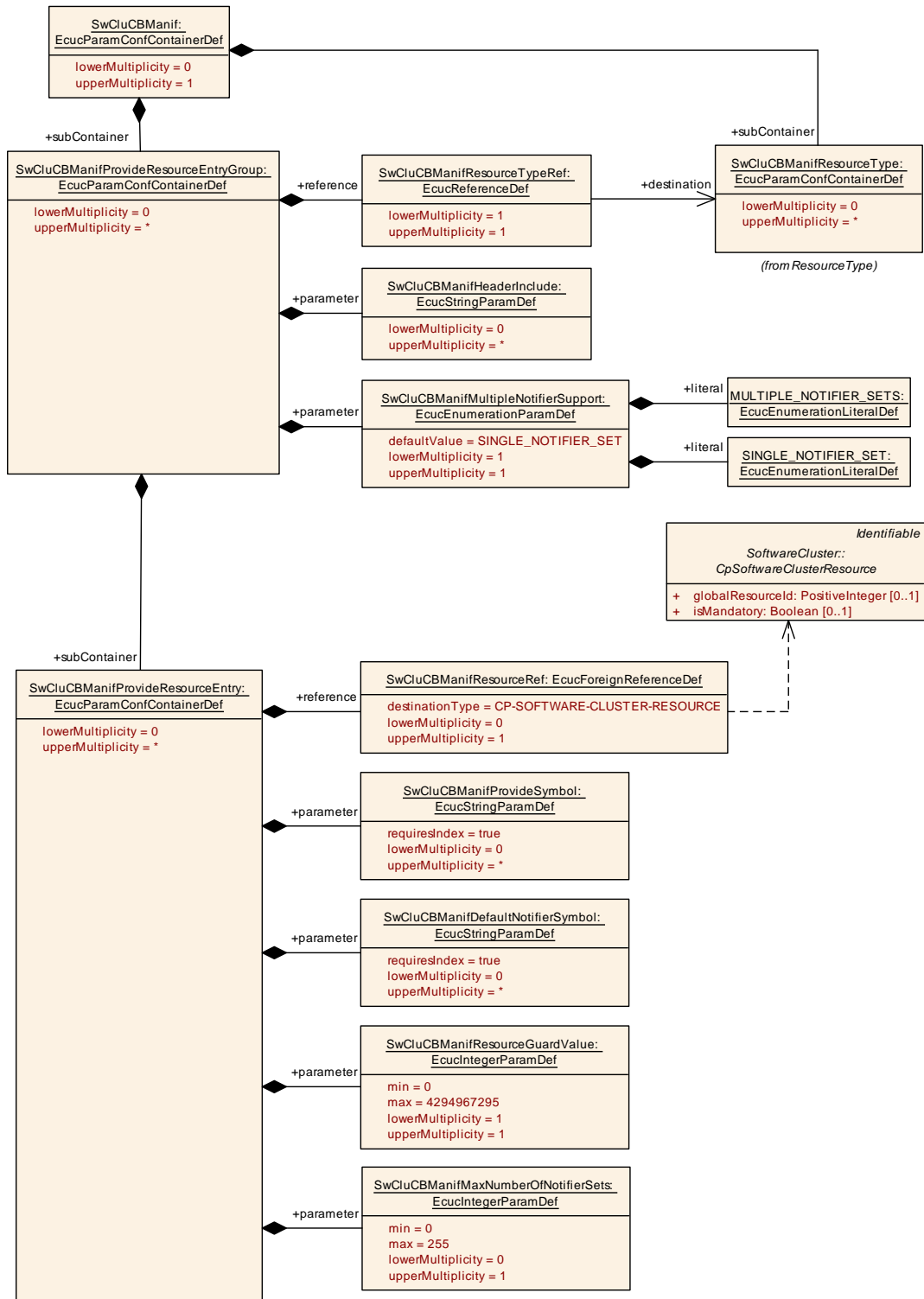

Figure 10.6: SwCluC Provide Resource Entry Group

SWS Item	[ECUC_SwCluC_00018]
Container Name	SwCluCManifestProvideResourceEntryGroup
Parent Container	SwCluCManifest
Description	Describes a group of provided resources in the Binary Manifest. The belonging handles are put into the Binary Manifest's tables into an consecutive order which supports an array based access. Tags: atp.Status=draft
Configuration Parameters	

SWS Item	[ECUC_SwCluC_00024]		
Parameter Name	SwCluCManifestHeaderInclude		
Parent Container	SwCluCManifestProvideResourceEntryGroup		
Description	Defines the header file(s) where the owner of the SwCluCManifestProvideResourceEntryGroup / SwCluCManifestRequireResourceEntryGroup has the declarations of the symbols for the handle initialization. Tags: atp.Status=draft		
Multiplicity	0..*		
Type	EcucStringParamDef		
Default value	-		
Regular Expression	-		
Post-Build Variant Multiplicity	false		
Post-Build Variant Value	false		
Multiplicity Configuration Class	Pre-compile time	X	All Variants
	Link time	-	
	Post-build time	-	
Value Configuration Class	Pre-compile time	X	All Variants
	Link time	-	
	Post-build time	-	
Scope / Dependency	scope: local		

SWS Item	[ECUC_SwCluC_00016]		
Parameter Name	SwCluCManifestMultipleNotifierSupport		
Parent Container	SwCluCManifestProvideResourceEntryGroup		
Description	SwCluCManifestMultipleNotifierSupport defines whether multiple Software Cluster can register on the notifier handles. For each possible connection a set of notifier handles is allocated. Tags: atp.Status=draft		
Multiplicity	1		
Type	EcucEnumerationParamDef		
Range	MULTIPLE_NOTIFIER_SETS	The provided resource supports the co-resident notifier connections to multiple required resources. Tags: atp.Status=draft	
	SINGLE_NOTIFIER_SET	The provided resource supports at most one connection of notifiers to a required resource.	
Default value	SINGLE_NOTIFIER_SET		
Multiplicity Configuration Class	Pre-compile time	X	All Variants
	Link time	-	
	Post-build time	-	





Value Configuration Class	Pre-compile time	X	All Variants
	Link time	–	
	Post-build time	–	
Scope / Dependency	scope: local		

SWS Item	[ECUC_SwCluC_00023]
Parameter Name	SwCluCBManifResourceTypeRef
Parent Container	SwCluCBManifProvideResourceEntryGroup
Description	Defines the resource type for all SwCluCBManifProvideResourceEntry / SwCluCBManifRequireResourceEntry Tags: atp.Status=draft
Multiplicity	1
Type	Reference to SwCluCBManifResourceType
Scope / Dependency	

Included Containers		
Container Name	Multiplicity	Scope / Dependency
SwCluCBManifProvideResourceEntry	0..*	Describes a single entry for a provided resource in the Binary Manifest. Tags: atp.Status=draft

10.2.5.2 Provided Resource Entry

SWS Item	[ECUC_SwclC_00009]
Container Name	SwCluCBManifProvideResourceEntry
Parent Container	SwCluCBManifProvideResourceEntryGroup
Description	Describes a single entry for a provided resource in the Binary Manifest. Tags: atp.Status=draft
Configuration Parameters	

SWS Item	[ECUC_SwCluC_00027]
Parameter Name	SwCluCBManifDefaultNotifierSymbol
Parent Container	SwCluCBManifProvideResourceEntry
Description	SwCluCBManifDefaultNotifierSymbol set the default value of a Notifier Handle put into the Modifiable Interface. The number and order of SwCluCBManifDefaultNotifierSymbol needs to match the number and order of SwCluCBManifNotifierHandle in the referenced SwCluCBManifResourceType. The parameter is defined as string in order to support the usage of symbols as initialize. Values have to be set as string in a C supported number format, e.g. 0x C001CAFE. In case the provide handle holds a pointer the address operator is part of the string, e.g. &myExampleFunction Tags: atp.Status=draft Attributes: requiresIndex=true
Multiplicity	0..*
Type	EcucStringParamDef





Default value	–
Regular Expression	–
Scope / Dependency	

SWS Item	[ECUC_SwCluC_00029]		
Parameter Name	SwCluCBManifMaxNumberOfNotifierSets		
Parent Container	SwCluCBManifProvideResourceEntry		
Description	SwCluCBManifMaxNumberOfNotifierSets defines the maximum number of possible required resources using notifier handles. It is required in case SwCluCBManifMultipleNotifierSupport is set to MULTIPLE_NOTIFIER_SETS. Tags: atp.Status=draft		
Multiplicity	0..1		
Type	EcucIntegerParamDef		
Range	0 .. 255		
Default value	–		
Multiplicity Configuration Class	Pre-compile time	X	All Variants
	Link time	–	
	Post-build time	–	
Value Configuration Class	Pre-compile time	X	All Variants
	Link time	–	
	Post-build time	–	
Scope / Dependency			

SWS Item	[ECUC_SwCluC_00026]		
Parameter Name	SwCluCBManifProvideSymbol		
Parent Container	SwCluCBManifProvideResourceEntry		
Description	SwCluCBManifProvideSymbol set the value of a Provide Handle put into the Immutable Interface. The number and order of SwCluCBManifProvideSymbols needs to match the number and order of SwCluCBManifProvideHandle in the referenced SwCluCBManifResourceType. The parameter is defined as string in order to support the usage of symbols as initialize. Values have to be set as string in a C supported number format, e.g. 0x C001CAFE. In case the provide handle holds a pointer the address operator is part of the string, e.g. &myExampleFunction Tags: atp.Status=draft Attributes: requiresIndex=true		
Multiplicity	0..*		
Type	EcucStringParamDef		
Default value	–		
Regular Expression	–		
Scope / Dependency			

SWS Item	[ECUC_SwCluC_00028]		
Parameter Name	SwCluCBManifResourceGuardValue		
Parent Container	SwCluCBManifProvideResourceEntry		





Description	SwCluCBManifResourceGuardValue provides guarding information checked by the Software Cluster connector. A provided resources and required resources of Software Clusters can only be connected, if the resource guarding values of provider and requester are equal. Tags: atp.Status=draft
Multiplicity	1
Type	EcucIntegerParamDef
Range	0 .. 4294967295
Default value	-
Scope / Dependency	

SWS Item	[ECUC_SwCluC_00025]
Parameter Name	SwCluCBManifResourceRef
Parent Container	SwCluCBManifProvideResourceEntry
Description	Reference to the CpSoftwareClusterResource determining the global resource Id. If the reference is not set, the global resource Id in the Binary Manifest will be set to 0 for this resource entry in order to indicate an invalid resource. Tags: atp.Status=draft
Multiplicity	0..1
Type	Foreign reference to CP-SOFTWARE-CLUSTER-RESOURCE
Scope / Dependency	

No Included Containers

10.2.5.3 Require Resource Entry Group

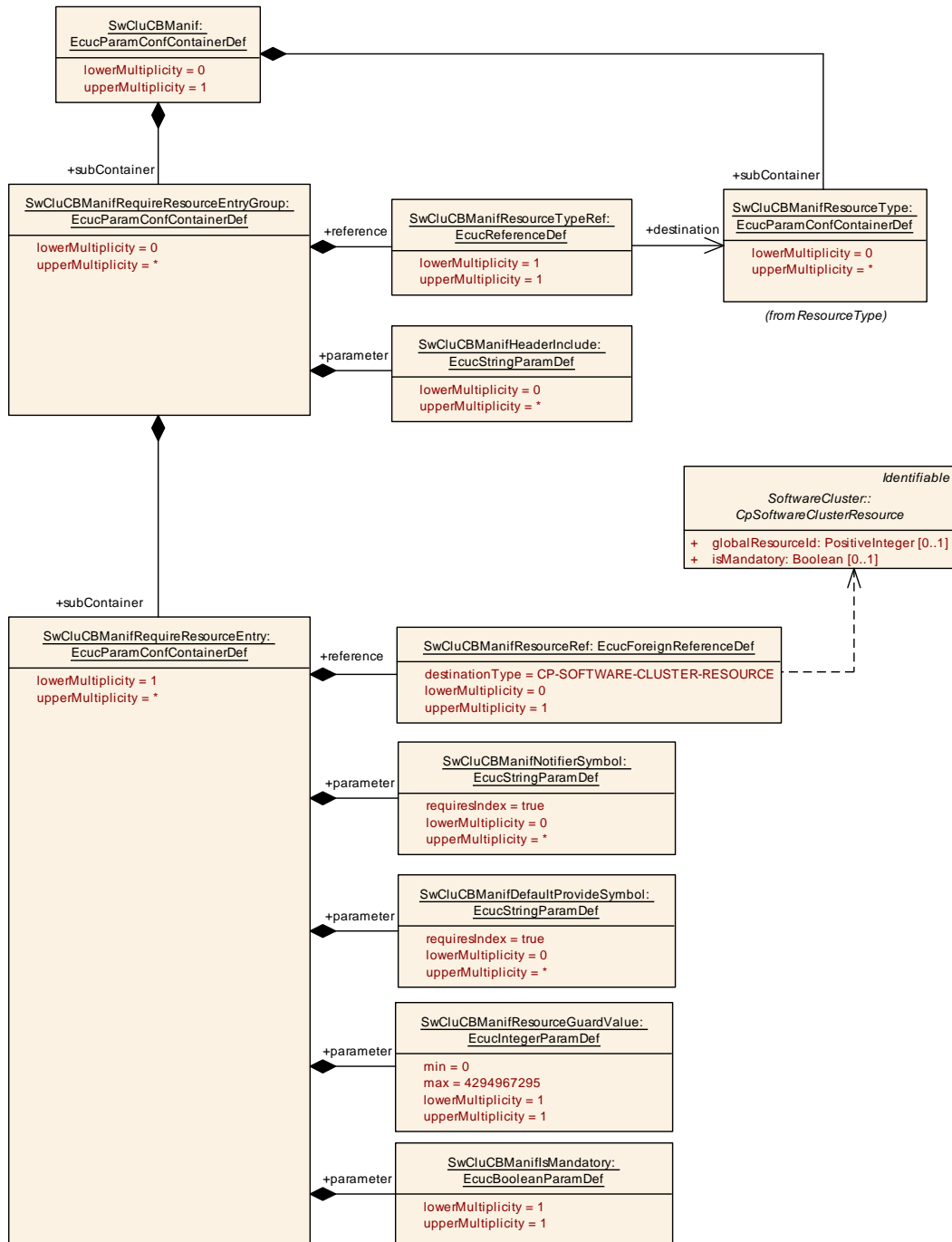

Figure 10.7: SwCluC Require Resource Entry Group

SWS Item	[ECUC_SwCluC_00019]
Container Name	SwCluCManifRequireResourceEntryGroup
Parent Container	SwCluCManif





Description	Describes a group of required resources in the Binary Manifest. The belonging handles are put into the Binary Manifest's tables into an consecutive order which supports an array based access. Tags: atp.Status=draft
Configuration Parameters	

SWS Item	[ECUC_SwCluC_00024]		
Parameter Name	SwCluCBManifHeaderInclude		
Parent Container	SwCluCBManifRequireResourceEntryGroup		
Description	Defines the header file(s) where the owner of the SwCluCBManifProvideResourceEntryGroup / SwCluCBManifRequireResourceEntryGroup has the declarations of the symbols for the handle initialization. Tags: atp.Status=draft		
Multiplicity	0..*		
Type	EcucStringParamDef		
Default value	-		
Regular Expression	-		
Post-Build Variant Multiplicity	false		
Post-Build Variant Value	false		
Multiplicity Configuration Class	Pre-compile time	X	All Variants
	Link time	-	
	Post-build time	-	
Value Configuration Class	Pre-compile time	X	All Variants
	Link time	-	
	Post-build time	-	
Scope / Dependency	scope: local		

SWS Item	[ECUC_SwCluC_00023]		
Parameter Name	SwCluCBManifResourceTypeRef		
Parent Container	SwCluCBManifRequireResourceEntryGroup		
Description	Defines the resource type for all SwCluCBManifProvideResourceEntry / SwCluCBManifRequireResourceEntry Tags: atp.Status=draft		
Multiplicity	1		
Type	Reference to SwCluCBManifResourceType		
Scope / Dependency			

Included Containers		
Container Name	Multiplicity	Scope / Dependency
SwCluCBManifRequireResourceEntry	1..*	Describes a single entry for a required resource in the Binary Manifest. Tags: atp.Status=draft

10.2.5.4 Require Resource Entry

SWS Item	[ECUC_SwClC_00021]
Container Name	SwCluCBManifRequireResourceEntry
Parent Container	SwCluCBManifRequireResourceEntryGroup
Description	Describes a single entry for a required resource in the Binary Manifest. Tags: atp.Status=draft
Configuration Parameters	

SWS Item	[ECUC_SwCluC_00031]
Parameter Name	SwCluCBManifDefaultProvideSymbol
Parent Container	SwCluCBManifRequireResourceEntry
Description	SwCluCBManifDefaultProvideSymbol set the default value of a Provide Handle put into the Modifiable Interface. The number and order of SwCluCBManifDefaultProvide Symbols needs to match the number and order of SwClCManifProvideHandles in the referenced SwCluCBManifResourceType. The parameter is defined as string in order to support the usage of symbols as initialize. Values have to be set as string in a C supported number format, e.g. 0x C001CAFE. In case the provide handle holds a pointer the address operator is part of the string, e.g. &myExampleFunction Tags: atp.Status=draft Attributes: requiresIndex=true
Multiplicity	0..*
Type	EcucStringParamDef
Default value	–
Regular Expression	–
Scope / Dependency	

SWS Item	[ECUC_SwCluC_00032]
Parameter Name	SwCluCBManifIsMandatory
Parent Container	SwCluCBManifRequireResourceEntry
Description	SwCluCBManifIsMandatory indicates, that the resource is mandatory to operate this Software Cluster. If the resource is not provided on the machine the connection process for this Software Cluster requiring this resource gets aborted. Tags: atp.Status=draft
Multiplicity	1
Type	EcucBooleanParamDef
Default value	–
Scope / Dependency	

SWS Item	[ECUC_SwCluC_00030]
Parameter Name	SwCluCBManifNotifierSymbol
Parent Container	SwCluCBManifRequireResourceEntry





Description	<p>SwCluCBManifNotifierSymbol set the value of a Notifier Handle put into the Immutable Interface. The number and order of SwCluCBManifNotifierSymbol needs to match the number and order of SwCluCBManifNotifierHandles in the referenced SwCluCBManif ResourceType.</p> <p>The parameter is defined as string in order to support the usage of symbols as initialize. Values have to be set as string in a C supported number format, e.g. 0x C001CAFE. In case the provide handle holds a pointer the address operator is part of the string, e.g. &myExampleFunction</p> <p>Tags: atp.Status=draft</p> <p>Attributes: requiresIndex=true</p>
Multiplicity	0..*
Type	EcucStringParamDef
Default value	–
Regular Expression	–
Scope / Dependency	

SWS Item	[ECUC_SwCluC_00028]	
Parameter Name	SwCluCBManifResourceGuardValue	
Parent Container	SwCluCBManifRequireResourceEntry	
Description	<p>SwCluCBManifResourceGuardValue provides guarding information checked by the Software Cluster connector. A provided resources and required resources of Software Clusters can only be connected, if the resource guarding values of provider and requester are equal.</p> <p>Tags: atp.Status=draft</p>	
Multiplicity	1	
Type	EcucIntegerParamDef	
Range	0 .. 4294967295	
Default value	–	
Scope / Dependency		

SWS Item	[ECUC_SwCluC_00025]	
Parameter Name	SwCluCBManifResourceRef	
Parent Container	SwCluCBManifRequireResourceEntry	
Description	<p>Reference to the CpSoftwareClusterResource determining the global resource Id. If the reference is not set, the global resource Id in the Binary Manifest will be set to 0 for this resource entry in order to indicate an invalid resource.</p> <p>Tags: atp.Status=draft</p>	
Multiplicity	0..1	
Type	Foreign reference to CP-SOFTWARE-CLUSTER-RESOURCE	
Scope / Dependency		

No Included Containers

10.2.5.5 Resource Type

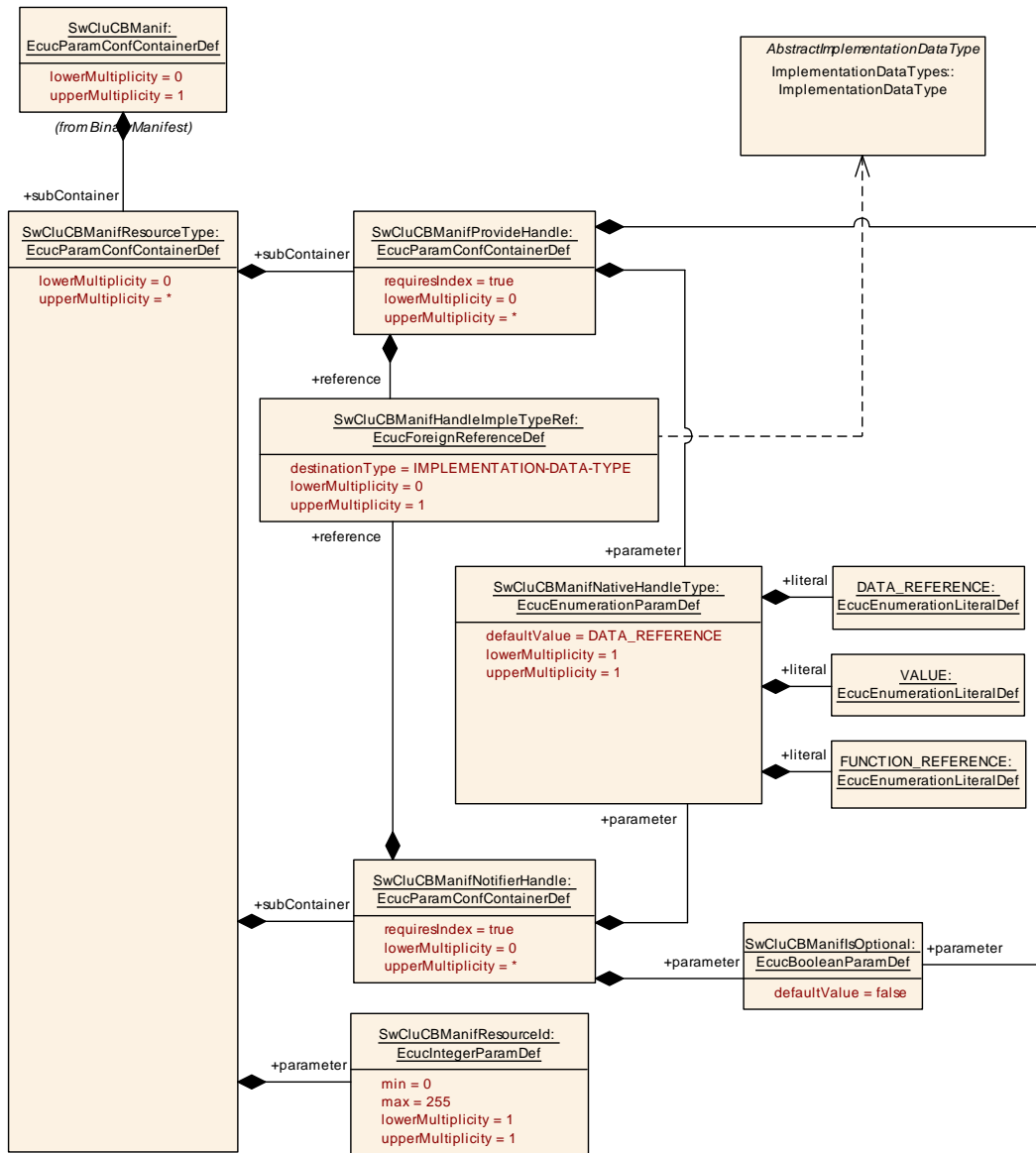

Figure 10.8: SwCluC resource type

SWS Item	[ECUC_SwCluC_00012]		
Container Name	SwCluCBManifResourceType		
Parent Container	SwCluCBManif		
Description	This container defines the structure of a resource type in the Binary Manifest. Tags: atp.Status=draft		
Multiplicity Configuration Class	Pre-compile time	X	All Variants
	Link time	–	
	Post-build time	–	
Configuration Parameters			

SWS Item	[ECUC_SwCluC_00017]		
Parameter Name	SwCluCManifestResourceId		
Parent Container	SwCluCManifestResourceType		
Description	Unique number of the resource type. Tags: atp.Status=draft		
Multiplicity	1		
Type	EcucIntegerParamDef		
Range	0 .. 255		
Default value	-		
Multiplicity Configuration Class	Pre-compile time	X	All Variants
	Link time	-	
	Post-build time	-	
Value Configuration Class	Pre-compile time	X	All Variants
	Link time	-	
	Post-build time	-	
Scope / Dependency	scope: ECU		

Included Containers		
Container Name	Multiplicity	Scope / Dependency
SwCluCManifestNotifierHandle	0..*	Defines a Notifier Handle and its properties for this resource type. Tags: atp.Status=draft
SwCluCManifestProvideHandle	0..*	Defines a Provide Handle and its properties for this resource type. Tags: atp.Status=draft

SWS Item	[ECUC_SwCluC_00013]		
Container Name	SwCluCManifestProvideHandle		
Parent Container	SwCluCManifestResourceType		
Description	Defines a Provide Handle and its properties for this resource type. Tags: atp.Status=draft Attributes: requiresIndex=true		
Configuration Parameters			

SWS Item	[ECUC_SwCluC_00099]		
Parameter Name	SwCluCManifestIsOptional		
Parent Container	SwCluCManifestProvideHandle		
Description	Indicates that this handle is optional and may not always exist for each Provide Resource Entry or Require Resource Entry.		
Multiplicity	1		
Type	EcucBooleanParamDef		
Default value	false		
Post-Build Variant Value	false		
Value Configuration Class	Pre-compile time	X	All Variants
	Link time	-	
	Post-build time	-	
Scope / Dependency			

SWS Item	[ECUC_SwCluC_00033]		
Parameter Name	SwCluCManifNativeHandleType		
Parent Container	SwCluCManifProvideHandle		
Description	<p>This paramter determines the underlying native type of the handle which can be</p> <ul style="list-style-type: none"> • pointer to variable • value • pointer to function <p>This information is required to correctly initialize the handle in the Immutable Interface or Modifiable Interface.</p> <p>Tags: atp.Status=draft</p>		
Multiplicity	1		
Type	EcucEnumerationParamDef		
Range	DATA_REFERENCE	Handle is pointer to variable	
	FUNCTION_REFERENCE	Handle is pointer to function	
	VALUE	Handle is a value	
	Tags: atp.Status=draft		
Default value	DATA_REFERENCE		
Multiplicity Configuration Class	Pre-compile time	X	All Variants
	Link time	–	
	Post-build time	–	
Value Configuration Class	Pre-compile time	X	All Variants
	Link time	–	
	Post-build time	–	
Scope / Dependency	scope: local		

SWS Item	[ECUC_SwCluC_00015]		
Parameter Name	SwCluCManifHandleImpleTypeRef		
Parent Container	SwCluCManifProvideHandle		
Description	<p>Reference to the ImplementationDataType of the handle. This type can be additionally configured to get a correct casting of the native handle type to the returned handel type.</p> <p>Tags: atp.Status=draft</p>		
Multiplicity	0..1		
Type	Foreign reference to IMPLEMENTATION-DATA-TYPE		
Post-Build Variant Value	false		
Value Configuration Class	Pre-compile time	X	All Variants
	Link time	–	
	Post-build time	–	
Scope / Dependency	scope: local		

No Included Containers

SWS Item	[ECUC_SwCluC_00014]		
Container Name	SwCluCManifNotifierHandle		
Parent Container	SwCluCManifResourceType		





Description	Defines a Notifier Handle and its properties for this resource type. Tags: atp.Status=draft Attributes: requiresIndex=true
Configuration Parameters	

SWS Item	[ECUC_SwCluC_00099]		
Parameter Name	SwCluCBManifIsOptional		
Parent Container	SwCluCBManifNotifierHandle		
Description	Indicates that this handle is optional and may not always exist for each Provide Resource Entry or Require Resource Entry.		
Multiplicity	1		
Type	EcucBooleanParamDef		
Default value	false		
Post-Build Variant Value	false		
Value Configuration Class	Pre-compile time	X	All Variants
	Link time	–	
	Post-build time	–	
Scope / Dependency			

SWS Item	[ECUC_SwCluC_00033]		
Parameter Name	SwCluCBManifNativeHandleType		
Parent Container	SwCluCBManifNotifierHandle		
Description	<p>This paramter determines the underlying native type of the handle which can be</p> <ul style="list-style-type: none"> • pointer to variable • value • pointer to function <p>This information is required to correctly initialize the handle in the Immutable Interface or Modifiable Interface.</p> <p>Tags: atp.Status=draft</p>		
Multiplicity	1		
Type	EcucEnumerationParamDef		
Range	DATA_REFERENCE	Handle is pointer to variable	
	FUNCTION_REFERENCE	Handle is pointer to function	
	VALUE	Handle is a value Tags: atp.Status=draft	
Default value	DATA_REFERENCE		
Multiplicity Configuration Class	Pre-compile time	X	All Variants
	Link time	–	
	Post-build time	–	
Value Configuration Class	Pre-compile time	X	All Variants
	Link time	–	
	Post-build time	–	
Scope / Dependency	scope: local		

SWS Item	[ECUC_SwCluC_00015]		
Parameter Name	SwCluCManifestHandleImpleTypeRef		
Parent Container	SwCluCManifestNotifierHandle		
Description	Reference to the ImplementationDataType of the handle. This type can be additionally configured to get a correct casting of the native handle type to the returned handel type. Tags: atp.Status=draft		
Multiplicity	0..1		
Type	Foreign reference to IMPLEMENTATION-DATA-TYPE		
Post-Build Variant Value	false		
Value Configuration Class	Pre-compile time	X	All Variants
	Link time	–	
	Post-build time	–	
Scope / Dependency	scope: local		

No Included Containers

10.2.6 Cross Cluster Communication

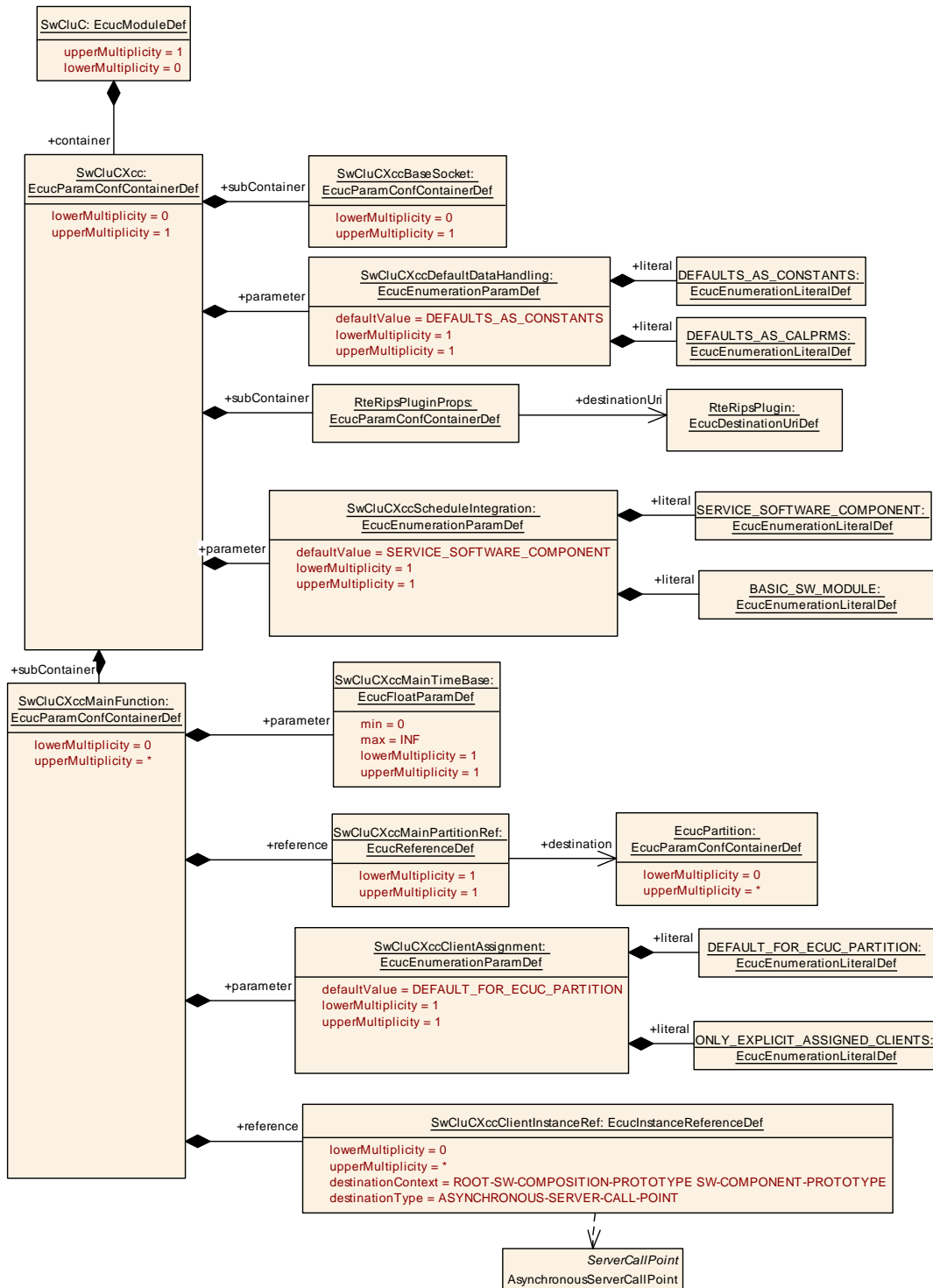

Figure 10.9: General Cross Cluster Communication Parameters

SWS Item	[ECUC_SwCluC_00075]
Container Name	SwCluCXcc
Parent Container	SwCluC
Description	Configuration of the Binary Manifest of the Software Cluster Connection Tags: atp.Status=draft
Configuration Parameters	

SWS Item	[ECUC_SwCluC_00084]		
Parameter Name	SwCluCXccDefaultDataHandling		
Parent Container	SwCluCXcc		
Description	SwCluCXccDefaultDataHandling defines whether the default data for unconnected RPortPrototypes of a Software Cluster are instantiated as fixed constants or as calibration parameter. Tags: atp.Status=draft		
Multiplicity	1		
Type	EcucEnumerationParamDef		
Range	DEFAULTS_AS_CALPRMS	Default data are implemented as calibration parameter. Tags: atp.Status=draft	
	DEFAULTS_AS_CONSTANTS	Default data are implemented as fixed constants. Tags: atp.Status=draft	
Default value	DEFAULTS_AS_CONSTANTS		
Multiplicity Configuration Class	Pre-compile time	X	All Variants
	Link time	–	
	Post-build time	–	
Value Configuration Class	Pre-compile time	X	All Variants
	Link time	–	
	Post-build time	–	
Scope / Dependency	scope: local		

SWS Item	[ECUC_SwCluC_00156]		
Parameter Name	SwCluCXccScheduleIntegration		
Parent Container	SwCluCXcc		
Description	Defines whether the SwCluC_Xcc_MainFunction is integrated via a Service Software Component with RunnableEntity or a Basic Software Module Description with SchedulableEntity.		
Multiplicity	1		
Type	EcucEnumerationParamDef		
Range	BASIC_SW_MODULE	SwCluC_Xcc_MainFunctions are integrated via a Basic Software Module Description with SchedulableEntity(s)	
	SERVICE_SOFTWARE_COMPONENT	SwCluC_Xcc_MainFunctions are integrated via a Service Software Component with Runnable Entity(s)	
Default value	SERVICE_SOFTWARE_COMPONENT		
Post-Build Variant Value	false		
Value Configuration Class	Pre-compile time	X	All Variants
	Link time	–	
	Post-build time	–	





Scope / Dependency	scope: local	
Included Containers		
Container Name	Multiplicity	Scope / Dependency
RteRipsPluginProps	1	This container defines the identity of the Rte Implementation Plug-in and provides the RTE relevant parameters of the Rte Implementation Plug-in. The shortName of the container defines the name of the Rte Implementation Plug-in used for the API infixes.
SwCluCXccBaseSocket	0..1	Maps a XccBaseSocket to the CpSoftwareClusterService Resource describing the XccBaseSocket resource in the clustered system. Maps a XccBaseSocket to a specific Ecuc Partition on which the XccBaseSocket is working. Tags: atp.Status=draft
SwCluCXccMainFunction	0..*	Defines the existence and properties of a SwCluC_Xcc_Main Function. Tags: atp.Status=draft

10.2.6.1 Cross Cluster Communication Base Socket

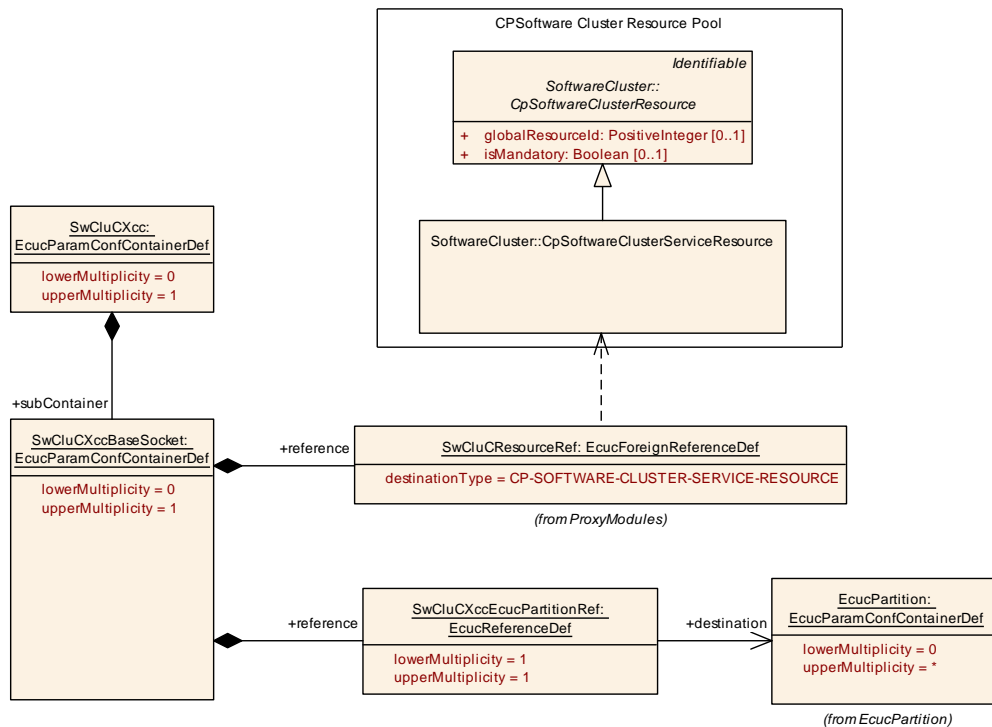

Figure 10.10: Cross Cluster Communication Base Socket

SWS Item	[ECUC_SwCluC_00076]
Container Name	SwCluCXccBaseSocket
Parent Container	SwCluCXcc





Description	Maps a XccBaseSocket to the CpSoftwareClusterServiceResource describing the XccBaseSocket resource in the clustered system. Maps a XccBaseSocket to a specific EcucPartition on which the XccBaseSocket is working. Tags: atp.Status=draft
Configuration Parameters	

SWS Item	[ECUC_SwCluC_00096]
Parameter Name	SwCluCResourceRef
Parent Container	SwCluCXccBaseSocket
Description	Reference to the CpSoftwareClusterServiceResource. Tags: atp.Status=draft
Multiplicity	1
Type	Foreign reference to CP-SOFTWARE-CLUSTER-SERVICE-RESOURCE
Scope / Dependency	scope: ECU

SWS Item	[ECUC_SwCluC_00077]		
Parameter Name	SwCluCXccEcucPartitionRef		
Parent Container	SwCluCXccBaseSocket		
Description	Reference to the EcucPartition on which the XccBaseSocket is available. Tags: atp.Status=draft		
Multiplicity	1		
Type	Reference to EcucPartition		
Multiplicity Configuration Class	Pre-compile time	X	All Variants
	Link time	–	
	Post-build time	–	
Value Configuration Class	Pre-compile time	X	All Variants
	Link time	–	
	Post-build time	–	
Scope / Dependency	scope: ECU		

No Included Containers

[SWS_SwCluC_CONSTR_03063][DRAFT] [SwCluCXccBaseSocket](#) relates only to a [CpSoftwareClusterServiceResource](#) of category [SWCLUSTER_RES_XCC_BASE_SOCKET](#) [The [SwCluCXccBaseSocket.SwCluCResourceRef](#) shall only reference a [CpSoftwareClusterServiceResource](#) of category [SWCLUSTER_RES_XCC_BASE_SOCKET](#).]()

10.2.6.2 Cross Cluster Communication Rte Plug-in Props

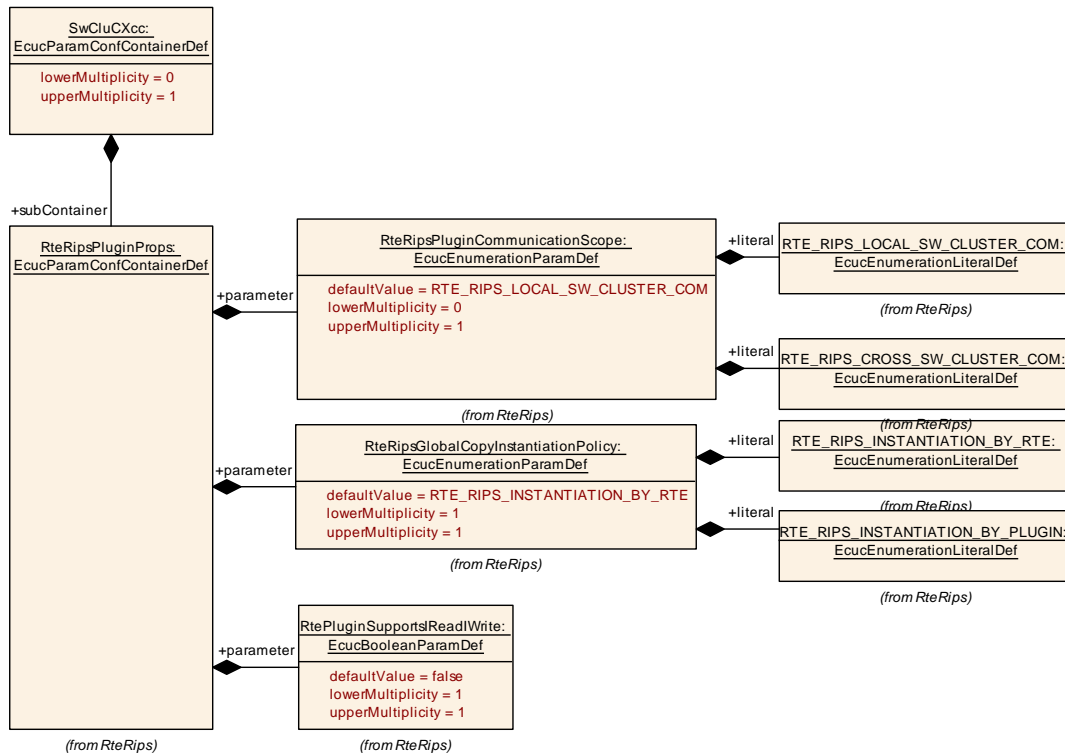

Figure 10.11: Cross Cluster Communication RTE Plug-In Properties

SWS Item	[ECUC_Rte_09173]
Container Name	RteRipsPluginProps
Parent Container	SwCluCXcc
Destination Uri Definition	RteRipsPlugin
Description	This container defines the identity of the Rte Implementation Plug-in and provides the RTE relevant parameters of the Rte Implementation Plug-in. The shortName of the container defines the name of the Rte Implementation Plug-in used for the API infixes.
Configuration Parameters	

SWS Item	[ECUC_Rte_09169]									
Parameter Name	RtePluginSupportsIReadIWrite									
Parent Container	RteRipsPluginProps									
Description	Denotes if or not the plug-in supports the Rte_Rips_IRead/IWrite macros for primitive data.									
Multiplicity	1									
Type	EcucBooleanParamDef									
Default value	false									
Post-Build Variant Value	false									
Value Configuration Class	<table border="1"> <tr> <td>Pre-compile time</td> <td>X</td> <td>All Variants</td> </tr> <tr> <td>Link time</td> <td>–</td> <td></td> </tr> <tr> <td>Post-build time</td> <td>–</td> <td></td> </tr> </table>	Pre-compile time	X	All Variants	Link time	–		Post-build time	–	
Pre-compile time	X	All Variants								
Link time	–									
Post-build time	–									
Scope / Dependency	scope: local									

SWS Item	[ECUC_Rte_09170]		
Parameter Name	RteRipsGlobalCopyInstantiationPolicy		
Parent Container	RteRipsPluginProps		
Description	Globally enables or disables the support for Rte Implementation Plug-Ins (RIPS)		
Multiplicity	1		
Type	EcucEnumerationParamDef		
Range	RTE_RIPS_INSTANTIATION_BY_PLUGIN	The Rte Implementation Plug-In shall provide the global copy(s) for each Communication Graph.	
	RTE_RIPS_INSTANTIATION_BY_RTE	The RTE shall provide an individual global copy for each Communication Graph.	
Default value	RTE_RIPS_INSTANTIATION_BY_RTE		
Post-Build Variant Value	false		
Value Configuration Class	Pre-compile time	X	All Variants
	Link time	–	
	Post-build time	–	
Scope / Dependency	scope: local		

SWS Item	[ECUC_Rte_09171]		
Parameter Name	RteRipsPluginCommunicationScope		
Parent Container	RteRipsPluginProps		
Description	Defines the communication scope for which the Rte Implementation Plug-Ins (RIPS) serves. If this parameter is not set, the default behavior RTE_RIPS_LOCAL_SW_CLUSTER_COM applies.		
Multiplicity	0..1		
Type	EcucEnumerationParamDef		
Range	RTE_RIPS_CROSS_SW_CLUSTER_COM	The Rte Implementation Plug-In handles the Cross Software Cluster Communication.	
	RTE_RIPS_LOCAL_SW_CLUSTER_COM	The Rte Implementation Plug-In handles the Local Software Cluster Communication.	
Default value	RTE_RIPS_LOCAL_SW_CLUSTER_COM		
Post-Build Variant Value	false		
Value Configuration Class	Pre-compile time	X	All Variants
	Link time	–	
	Post-build time	–	
Scope / Dependency	scope: local		

Included Containers		
Container Name	Multiplicity	Scope / Dependency
RteRipsPluginCommunicationType Support	0..1	This container defines the different elements of communication graphs that the plugin is responsible for. Tags: atp.Status=draft

10.2.6.3 Cross Cluster Communication Main Function

SWS Item	[ECUC_SwCluC_00157]		
Container Name	SwCluCXccMainFunction		
Parent Container	SwCluCXcc		
Description	Defines the existence and properties of a SwCluC_Xcc_MainFunction. Tags: atp.Status=draft		
Post-Build Variant Multiplicity	false		
Multiplicity Configuration Class	Pre-compile time	X	All Variants
	Link time	–	
	Post-build time	–	
Configuration Parameters			

SWS Item	[ECUC_SwCluC_00160]		
Parameter Name	SwCluCXccClientAssignment		
Parent Container	SwCluCXccMainFunction		
Description	Defines if the SwCluC_Xcc_MainFunction is used as default main function for all clients which are not referenced explicitly by a SwCluCXccClientInstanceRef on this Ecuc Partition		
Multiplicity	1		
Type	EcucEnumerationParamDef		
Range	DEFAULT_FOR_ECUC_PARTITION	The related SwCluC_Xcc_MainFunction is used as default main function to handle timeout for all clients which are not referenced explicitly by a SwCluCXccClientInstanceRef on this EcucPartition.	
	ONLY_EXPLICIT_ASSIGNED_CLIENTS	The related SwCluC_Xcc_MainFunction only handles timeout for clients which are explicitly referenced by a SwCluCXccClientInstanceRef by this SwCluCXccMainFunction.	
Default value	DEFAULT_FOR_ECUC_PARTITION		
Post-Build Variant Value	false		
Value Configuration Class	Pre-compile time	X	All Variants
	Link time	–	
	Post-build time	–	
Scope / Dependency	scope: local		

SWS Item	[ECUC_SwCluC_00158]		
Parameter Name	SwCluCXccMainTimeBase		
Parent Container	SwCluCXccMainFunction		
Description	The period between successive calls to according instance of SwCluC_Xcc_Main Function in seconds. This parameter may be used by the SwCluC generator to transform the given timeout values to internal implementation specific counter or tick values.		
Multiplicity	1		
Type	EcucFloatParamDef		
Range	[0 .. INF]		
Default value	–		
Post-Build Variant Value	false		
Value Configuration Class	Pre-compile time	X	All Variants
	Link time	–	
	Post-build time	–	





Scope / Dependency	scope: local
---------------------------	--------------

SWS Item	[ECUC_SwCluC_00161]		
Parameter Name	SwCluCXccClientInstanceRef		
Parent Container	SwCluCXccMainFunction		
Description	Reference to an AsynchronousServerCallPoint		
Multiplicity	0..*		
Type	Instance reference to ASYNCHRONOUS-SERVER-CALL-POINT context: ROOT-SW-COMPOSITION-PROTOTYPE SW-COMPONENT-PROTOTYPE		
Post-Build Variant Multiplicity	false		
Post-Build Variant Value	false		
Multiplicity Configuration Class	Pre-compile time	X	All Variants
	Link time	–	
	Post-build time	–	
Value Configuration Class	Pre-compile time	X	All Variants
	Link time	–	
	Post-build time	–	
Scope / Dependency	scope: local		

SWS Item	[ECUC_SwCluC_00159]		
Parameter Name	SwCluCXccMainPartitionRef		
Parent Container	SwCluCXccMainFunction		
Description	Reference to EcucPartition, where the according SwCluC_Xcc_MainFunction instance is assigned to.		
Multiplicity	1		
Type	Reference to EcucPartition		
Post-Build Variant Value	false		
Value Configuration Class	Pre-compile time	X	All Variants
	Link time	–	
	Post-build time	–	
Scope / Dependency			

No Included Containers

[SWS_SwCluC_CONSTR_03403] [It is only allowed to configure at most one [SwCluCXccMainFunction](#) where [SwCluCXccClientAssignment](#) is set to [DEFAULT_FOR_ECUC_PARTITION](#) per [EcucPartition](#).] ([SRS_SwCluC_00100](#), [SRS_SwCluC_00103](#))

10.2.7 Proxy Modules

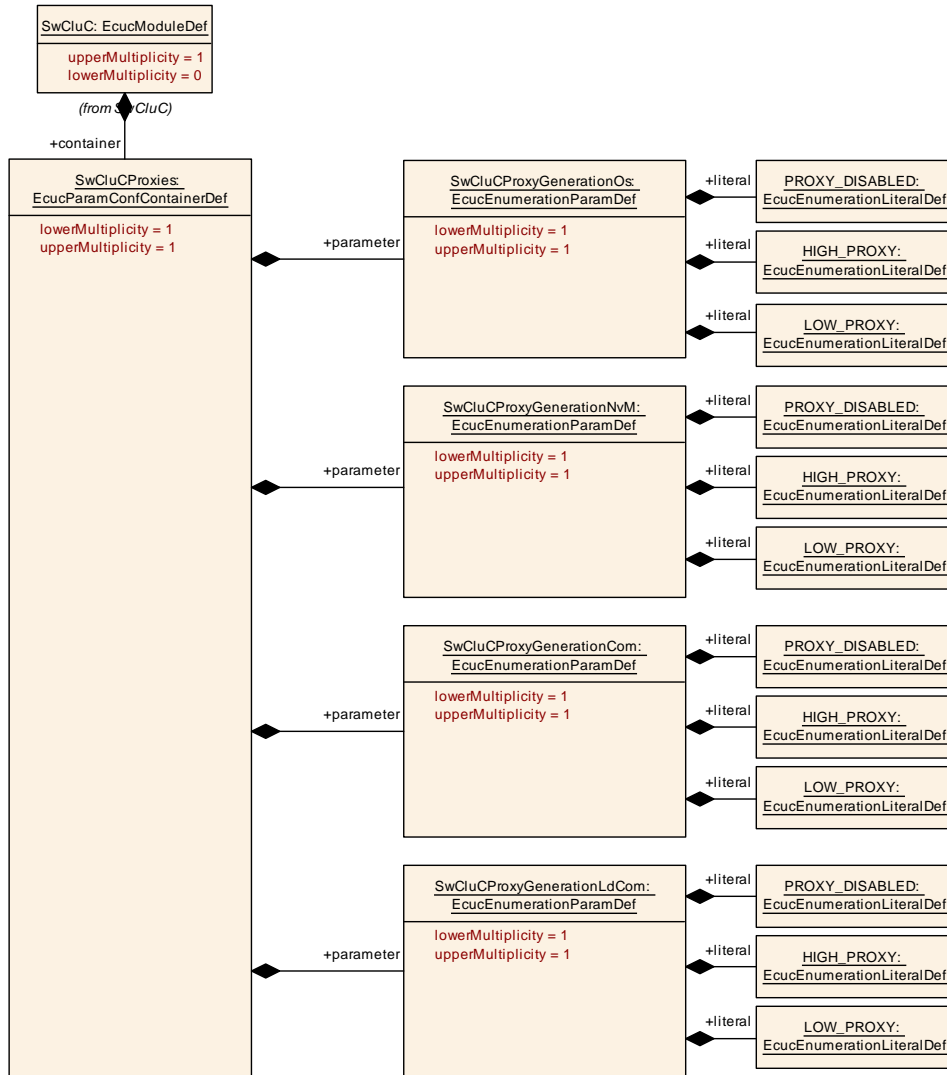

Figure 10.12: General Proxies Parameters

SWS Item	[ECUC_SwCluC_00036]		
Container Name	SwCluCProxies		
Parent Container	SwCluC		
Description	General configuration of the Proxy Modules of Software Cluster Connection Tags: atp.Status=draft		
Multiplicity Configuration Class	Pre-compile time	X	All Variants
	Link time	–	
	Post-build time	–	
Configuration Parameters			

SWS Item	[ECUC_SwCluC_00100]		
Parameter Name	SwCluCProxyGenerationCom		
Parent Container	SwCluCProxies		
Description	Defines whether the Com Proxy code and models are generated. Tags: atp.Status=draft		
Multiplicity	1		
Type	EcucEnumerationParamDef		
Range	HIGH_PROXY	Enables the according High Proxy Module code and AUTOSAR model generation. Tags: atp.Status=draft	
	LOW_PROXY	Enables the according Low Proxy Module code and AUTOSAR model generation. Tags: atp.Status=draft	
	PROXY_DISABLED	Disables the Proxy Module code and AUTOSAR model generation. Tags: atp.Status=draft	
Multiplicity Configuration Class	Pre-compile time	X	All Variants
	Link time	–	
	Post-build time	–	
Value Configuration Class	Pre-compile time	X	All Variants
	Link time	–	
	Post-build time	–	
Scope / Dependency	scope: ECU		

SWS Item	[ECUC_SwCluC_00102]		
Parameter Name	SwCluCProxyGenerationDcm		
Parent Container	SwCluCProxies		
Description	Defines whether the Dcm Proxy code and models are generated. Tags: atp.Status=draft		
Multiplicity	1		
Type	EcucEnumerationParamDef		
Range	HIGH_PROXY	Enables the according High Proxy Module code and AUTOSAR model generation. Tags: atp.Status=draft	
	LOW_PROXY	Enables the according Low Proxy Module code and AUTOSAR model generation.	
	PROXY_DISABLED	Disables the Proxy Module code and AUTOSAR model generation. Tags: atp.Status=draft	
Multiplicity Configuration Class	Pre-compile time	X	All Variants
	Link time	–	
	Post-build time	–	
Value Configuration Class	Pre-compile time	X	All Variants
	Link time	–	
	Post-build time	–	
Scope / Dependency	scope: ECU		

SWS Item	[ECUC_SwCluC_00103]		
Parameter Name	SwCluCProxyGenerationDem		
Parent Container	SwCluCProxies		
Description	Defines whether the Dem Proxy code and models are generated. Tags: atp.Status=draft		
Multiplicity	1		
Type	EcucEnumerationParamDef		
Range	HIGH_PROXY	Enables the according High Proxy Module code and AUTOSAR model generation. Tags: atp.Status=draft	
	LOW_PROXY	Enables the according Low Proxy Module code and AUTOSAR model generation. Tags: atp.Status=draft	
	PROXY_DISABLED	Disables the Proxy Module code and AUTOSAR model generation. Tags: atp.Status=draft	
Multiplicity Configuration Class	Pre-compile time	X	All Variants
	Link time	–	
	Post-build time	–	
Value Configuration Class	Pre-compile time	X	All Variants
	Link time	–	
	Post-build time	–	
Scope / Dependency	scope: ECU		

SWS Item	[ECUC_SwCluC_00104]		
Parameter Name	SwCluCProxyGenerationFiM		
Parent Container	SwCluCProxies		
Description	Defines whether the FiM Proxy code and models are generated. Tags: atp.Status=draft		
Multiplicity	1		
Type	EcucEnumerationParamDef		
Range	HIGH_PROXY	Enables the according High Proxy Module code and AUTOSAR model generation. Tags: atp.Status=draft	
	LOW_PROXY	Enables the according Low Proxy Module code and AUTOSAR model generation. Tags: atp.Status=draft	
	PROXY_DISABLED	Disables the Proxy Module code and AUTOSAR model generation. Tags: atp.Status=draft	
Multiplicity Configuration Class	Pre-compile time	X	All Variants
	Link time	–	
	Post-build time	–	
Value Configuration Class	Pre-compile time	X	All Variants
	Link time	–	
	Post-build time	–	
Scope / Dependency	scope: ECU		

SWS Item	[ECUC_SwCluC_00101]		
Parameter Name	SwCluCProxyGenerationLdCom		
Parent Container	SwCluCProxies		
Description	Defines whether the LdCom Proxy code and models are generated. Tags: atp.Status=draft		
Multiplicity	1		
Type	EcucEnumerationParamDef		
Range	HIGH_PROXY	Enables the according High Proxy Module code and AUTOSAR model generation. Tags: atp.Status=draft	
	LOW_PROXY	Enables the according Low Proxy Module code and AUTOSAR model generation. Tags: atp.Status=draft	
	PROXY_DISABLED	Disables the Proxy Module code and AUTOSAR model generation. Tags: atp.Status=draft	
Multiplicity Configuration Class	Pre-compile time	X	All Variants
	Link time	–	
	Post-build time	–	
Value Configuration Class	Pre-compile time	X	All Variants
	Link time	–	
	Post-build time	–	
Scope / Dependency	scope: ECU		

SWS Item	[ECUC_SwCluC_00038]		
Parameter Name	SwCluCProxyGenerationNvM		
Parent Container	SwCluCProxies		
Description	Defines whether the NvM Proxy code and models are generated. Tags: atp.Status=draft		
Multiplicity	1		
Type	EcucEnumerationParamDef		
Range	HIGH_PROXY	Enables the according High Proxy Module code and AUTOSAR model generation.	
	LOW_PROXY	Enables the according Low Proxy Module code and AUTOSAR model generation.	
	PROXY_DISABLED	Disables the Proxy Module code and AUTOSAR model generation.	
Multiplicity Configuration Class	Pre-compile time	X	All Variants
	Link time	–	
	Post-build time	–	
Value Configuration Class	Pre-compile time	X	All Variants
	Link time	–	
	Post-build time	–	
Scope / Dependency	scope: ECU		

SWS Item	[ECUC_SwCluC_00037]		
Parameter Name	SwCluCProxyGenerationOs		
Parent Container	SwCluCProxies		
Description	Defines whether the Os Proxy code and models are generated. Tags: atp.Status=draft		
Multiplicity	1		
Type	EcucEnumerationParamDef		
Range	HIGH_PROXY	Enables the according High Proxy Module code and AUTOSAR model generation. Tags: atp.Status=draft	
	LOW_PROXY	Enables the according Low Proxy Module code and AUTOSAR model generation. Tags: atp.Status=draft	
	PROXY_DISABLED	Disables the Proxy Module code and AUTOSAR model generation Tags: atp.Status=draft	
Multiplicity Configuration Class	Pre-compile time	X	All Variants
	Link time	–	
	Post-build time	–	
Value Configuration Class	Pre-compile time	X	All Variants
	Link time	–	
	Post-build time	–	
Scope / Dependency	scope: ECU		

Included Containers		
Container Name	Multiplicity	Scope / Dependency
SwCluCComProxy	0..1	LdCom Proxy specific parameters. Tags: atp.Status=draft
SwCluCDcmProxy	0..1	Dcm Proxy specific parameters. Tags: atp.Status=draft
SwCluCDemProxy	0..1	DemProxy specific parameters. Tags: atp.Status=draft
SwCluCFiMProxy	0..1	FiM Proxy specific parameters. Tags: atp.Status=draft
SwCluCLdComProxy	0..1	LdCom Proxy specific parameters. Tags: atp.Status=draft
SwCluCNvMProxy	0..1	NvM Proxy specific parameters. Tags: atp.Status=draft
SwCluCOsProxy	0..1	Os Proxy specific parameters. Tags: atp.Status=draft

10.2.7.1 NvM Proxy

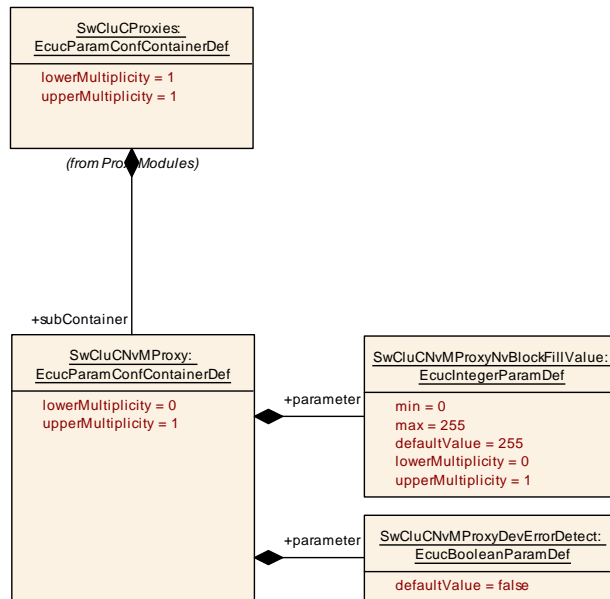

Figure 10.13: NvM Proxy Parameter

SWS Item	[ECUC_SwCluC_00039]		
Container Name	SwCluCNvMProxy		
Parent Container	SwCluCProxies		
Description	NvM Proxy specific parameters. Tags: atp.Status=draft		
Multiplicity Configuration Class	Pre-compile time	X	All Variants
	Link time	–	
	Post-build time	–	
Configuration Parameters			

SWS Item	[ECUC_SwCluC_00083]		
Parameter Name	SwCluCNvMProxyDevErrorDetect		
Parent Container	SwCluCNvMProxy		
Description	Switches the development error detection and notification on or off. <ul style="list-style-type: none"> true: detection and notification is enabled. false: detection and notification is disabled. 		
Multiplicity	1		
Type	EcucBooleanParamDef		
Default value	false		
Post-Build Variant Value	false		
Value Configuration Class	Pre-compile time	X	All Variants
	Link time	–	
	Post-build time	–	
Scope / Dependency	scope: local		

SWS Item	[ECUC_SwCluC_00055]		
Parameter Name	SwCluCNvMProxyNvBlockFillValue		
Parent Container	SwCluCNvMProxy		
Description	<p>Defines the default value used to fill unused bytes in NvBlock space in case NvBlock length in Application Software Cluster < NvBlock length configured in NvM of Host Software Cluster.</p> <p>Dependent on NvM Proxy implementation this parameter is only relevant for NvM Low Proxy or NvM High Proxy</p> <p>Tags: atp.Status=draft</p>		
Multiplicity	0..1		
Type	EcucIntegerParamDef		
Range	0 .. 255		
Default value	255		
Post-Build Variant Value	false		
Multiplicity Configuration Class	Pre-compile time	X	All Variants
	Link time	–	
	Post-build time	–	
Value Configuration Class	Pre-compile time	X	All Variants
	Link time	–	
	Post-build time	–	
Scope / Dependency	scope: ECU		

Included Containers		
Container Name	Multiplicity	Scope / Dependency
SwCluCNvMBaseSocket	1..*	<p>This container configures how many EcucPartitions specific API links are required for the NvM Proxy and to which cluster resource the API set belongs.</p> <p>In the NvM Low Proxy all offered API sets needs to be configured. In the NvM High Proxy only the ones are configured which are offered inside this Application Software Cluster.</p> <p>The reference SwCluCProxyEcucPartitionRef denotes the Ecuc Partition on which the API set is provided.</p> <p>Tags: atp.Status=draft</p>
SwCluCNvMProxyNvBlock	1..*	<p>Maps a NvMBlockDescriptor to the CpSoftwareClusterService Resource describing the NvBlock resource in the clustered system.</p> <p>Tags: atp.Status=draft</p>

10.2.7.1.1 NvM Base Socket

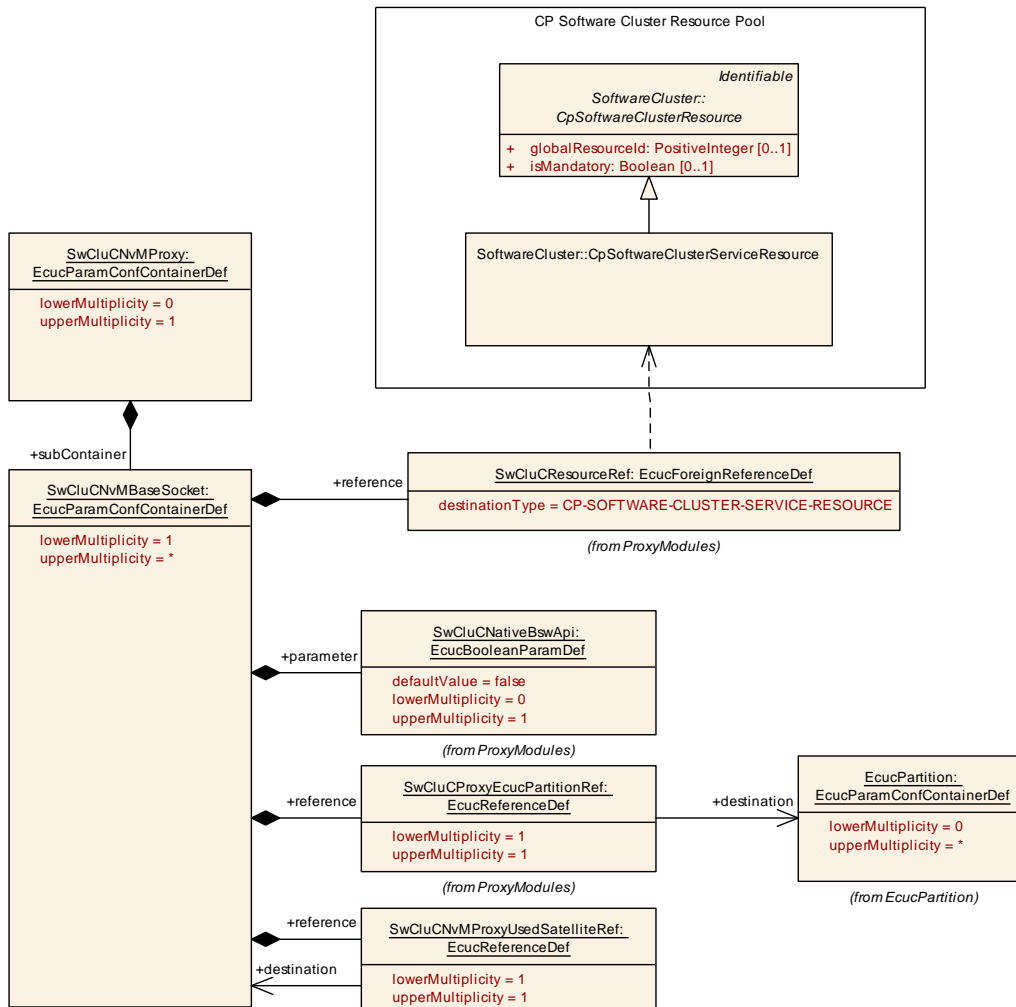

Figure 10.14: NvM Proxy Base Socket

SWS Item	[ECUC_SwCluC_00056]		
Container Name	SwCluCnVMBaseSocket		
Parent Container	SwCluCnVMProxy		
Description	<p>This container configures how many EcucPartitions specific API links are required for the NvM Proxy and to which cluster resource the API set belongs.</p> <p>In the NvM Low Proxy all offered API sets need to be configured. In the NvM High Proxy only the ones are configured which are offered inside this Application Software Cluster.</p> <p>The reference SwCluCProxyEcucPartitionRef denotes the EcucPartition on which the API set is provided.</p> <p>Tags: atp.Status=draft</p>		
Multiplicity Configuration Class	Pre-compile time	X	All Variants
	Link time	–	
	Post-build time	–	
Configuration Parameters			

SWS Item	[ECUC_SwCluC_00058]		
Parameter Name	SwCluCNativeBswApi		
Parent Container	SwCluCnVMBaseSocket		
Description	<p>Defines if the native C-API without pre or suffixes is offered in the Application Software Cluster on this EcucPartition.</p> <p>This Parameter is only relevant for the NvM High Proxy.</p> <p>Tags: atp.Status=draft</p>		
Multiplicity	0..1		
Type	EcucBooleanParamDef		
Default value	false		
Post-Build Variant Value	false		
Multiplicity Configuration Class	Pre-compile time	X	All Variants
	Link time	–	
	Post-build time	–	
Value Configuration Class	Pre-compile time	X	All Variants
	Link time	–	
	Post-build time	–	
Scope / Dependency	scope: ECU		

SWS Item	[ECUC_SwCluC_00082]		
Parameter Name	SwCluCnVMPProxyUsedSatelliteRef		
Parent Container	SwCluCnVMBaseSocket		
Description	<p>Reference to the SwCluCnVMBaseSocket which has access to a satellite of the NvM. The owning SwCluCnVMBaseSocket uses the NvM satellite of the referenced SwCluCnVMBaseSocket.</p> <p>Tags: atp.Status=draft</p>		
Multiplicity	1		
Type	Reference to SwCluCnVMBaseSocket		
Multiplicity Configuration Class	Pre-compile time	X	All Variants
	Link time	–	
	Post-build time	–	
Value Configuration Class	Pre-compile time	X	All Variants
	Link time	–	
	Post-build time	–	
Scope / Dependency	scope: ECU		

SWS Item	[ECUC_SwCluC_00059]		
Parameter Name	SwCluCProxyEcucPartitionRef		
Parent Container	SwCluCnVMBaseSocket		
Description	<p>Reference to the EcucPartition.</p> <p>Tags: atp.Status=draft</p>		
Multiplicity	1		
Type	Reference to EcucPartition		
Multiplicity Configuration Class	Pre-compile time	X	All Variants
	Link time	–	
	Post-build time	–	
Value Configuration Class	Pre-compile time	X	All Variants
	Link time	–	





	Post-build time	-	
Scope / Dependency	scope: ECU		

SWS Item	[ECUC_SwCluC_00092]
Parameter Name	SwCluCResourceRef
Parent Container	SwCluCNvMBaseSocket
Description	Reference to the CpSoftwareClusterServiceResource. Tags: atp.Status=draft
Multiplicity	1
Type	Foreign reference to CP-SOFTWARE-CLUSTER-SERVICE-RESOURCE
Scope / Dependency	scope: ECU

No Included Containers

[SWS_SwCluC_CONSTR_02130]{DRAFT} [SwCluCNvMBaseSocket](#) relates only to a [CpSoftwareClusterServiceResource](#) of category [SWCLUSTER_RES_NVM_BASE_SOCKET](#) [The [SwCluCNvMBaseSocket.SwCluCResourceRef](#) shall only reference a [CpSoftwareClusterServiceResource](#) of category [SWCLUSTER_RES_NVM_BASE_SOCKET](#).]()

10.2.7.1.2 NvM Proxy NvBlock configuration

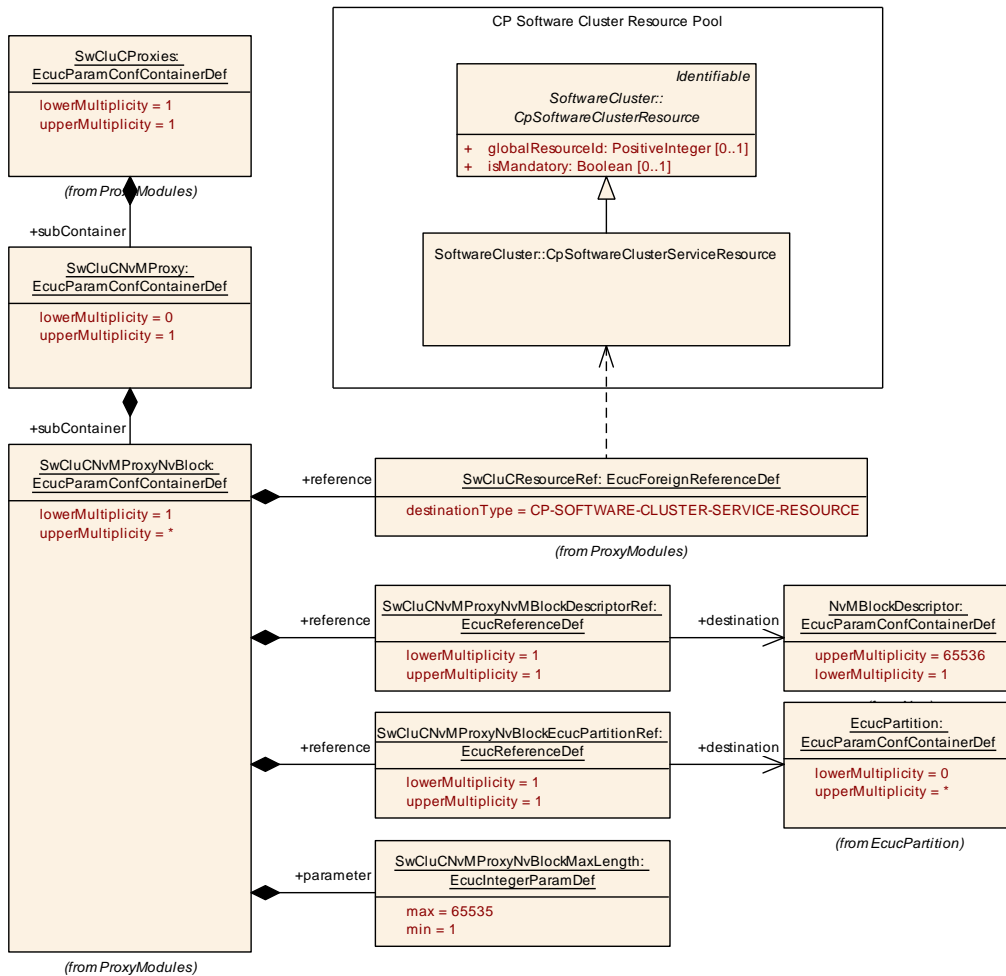

Figure 10.15: NvM Proxy NvBlock

SWS Item	[ECUC_SwCluC_00040]		
Container Name	SwCluCNvMProxyNvBlock		
Parent Container	SwCluCNvMProxy		
Description	Maps a NvMBlockDescriptor to the CpSoftwareClusterServiceResource describing the NvBlock resource in the clustered system. Tags: atp.Status=draft		
Multiplicity Configuration Class	Pre-compile time	X	All Variants
	Link time	–	
	Post-build time	–	
Configuration Parameters			

SWS Item	[ECUC_SwCluC_00043]		
Parameter Name	SwCluCNvMProxyNvBlockMaxLength		
Parent Container	SwCluCNvMProxyNvBlock		





Description	Defines the maximum NV block data length in bytes. Tags: atp.Status=draft		
Multiplicity	1		
Type	EcucIntegerParamDef		
Range	1 .. 65535		
Default value	–		
Post-Build Variant Value	false		
Multiplicity Configuration Class	Pre-compile time	X	All Variants
	Link time	–	
	Post-build time	–	
Value Configuration Class	Pre-compile time	X	All Variants
	Link time	–	
	Post-build time	–	
Scope / Dependency	scope: ECU		

SWS Item	[ECUC_SwCluC_00060]		
Parameter Name	SwCluCnVmProxyNvBlockEcucPartitionRef		
Parent Container	SwCluCnVmProxyNvBlock		
Description	Reference to the EcucPartition on which the NvM Proxy offers the NvBlock access (call of APIfunctions, callback functions and Ports on the Service Software Component) Tags: atp.Status=draft		
Multiplicity	1		
Type	Reference to EcucPartition		
Multiplicity Configuration Class	Pre-compile time	X	All Variants
	Link time	–	
	Post-build time	–	
Value Configuration Class	Pre-compile time	X	All Variants
	Link time	–	
	Post-build time	–	
Scope / Dependency	scope: ECU		

SWS Item	[ECUC_SwCluC_00042]		
Parameter Name	SwCluCnVmProxyNvMBlockDescriptorRef		
Parent Container	SwCluCnVmProxyNvBlock		
Description	Reference to the NvMBlockDescriptor Tags: atp.Status=draft		
Multiplicity	1		
Type	Reference to NvMBlockDescriptor		
Scope / Dependency	scope: ECU		

SWS Item	[ECUC_SwCluC_00091]		
Parameter Name	SwCluCResourceRef		
Parent Container	SwCluCnVmProxyNvBlock		
Description	Reference to the CpSoftwareClusterServiceResource. Tags: atp.Status=draft		
Multiplicity	1		





Type	Foreign reference to CP-SOFTWARE-CLUSTER-SERVICE-RESOURCE
Scope / Dependency	scope: ECU

No Included Containers

[SWS_SwCluC_CONSTR_02131]{DRAFT} SwCluCNvMProxyNvBlock relates only to a CpSoftwareClusterServiceResource of category SWCLUSTER_RES_NV_BLOCK [The `SwCluCNvMProxyNvBlock.SwCluCResourceRef` shall only reference a `CpSoftwareClusterServiceResource` of category `SWCLUSTER_RES_NV_BLOCK`.]()

10.2.7.2 Os Proxy

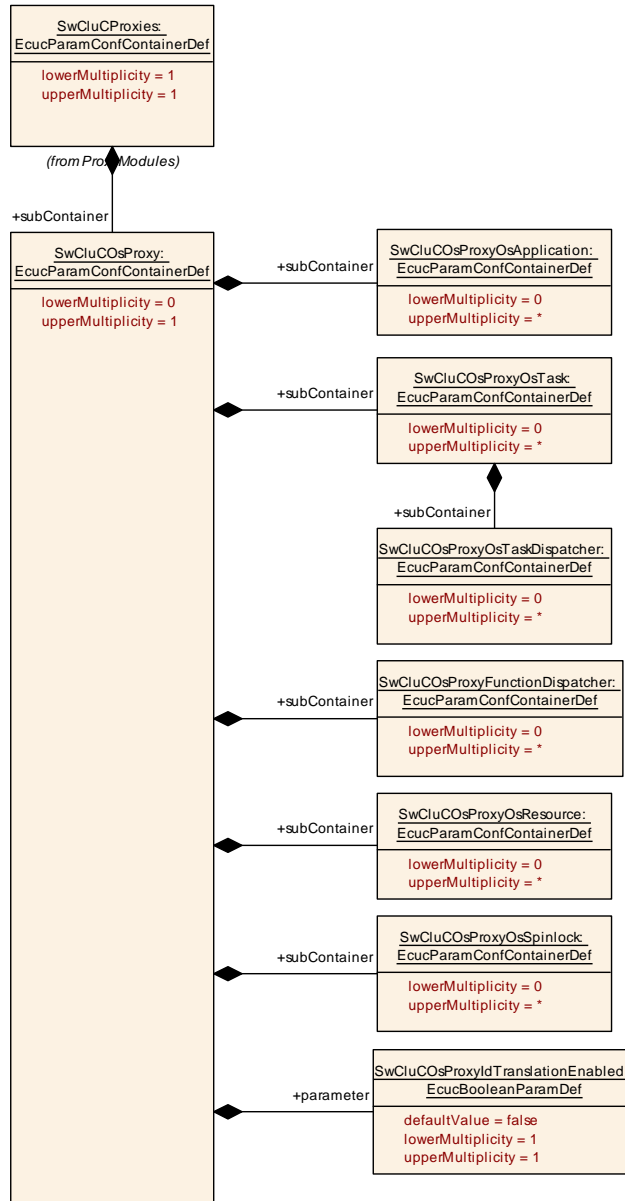

Figure 10.16: Os Proxy Parameter

SWS Item	[ECUC_SwCluC_00085]		
Container Name	SwCluCOsProxy		
Parent Container	SwCluCProxies		
Description	Os Proxy specific parameters. Tags: atp.Status=draft		
Multiplicity Configuration Class	Pre-compile time	X	All Variants
	Link time	–	
	Post-build time	–	
Configuration Parameters			

SWS Item	[ECUC_SwCluC_00155]		
Parameter Name	SwCluCOsProxyIdTranslationEnabled		
Parent Container	SwCluCOsProxy		
Description	Enables the translation of core IDs and application IDs between Host SW Cluster and Application SW Cluster - true: IDs translation from HOST into Application SW Cluster specific ones is enabled. - false: IDs translation from HOST into Application SW Cluster specific ones is disabled.		
Multiplicity	1		
Type	EcucBooleanParamDef		
Default value	false		
Post-Build Variant Value	false		
Value Configuration Class	Pre-compile time	X	All Variants
	Link time	–	
	Post-build time	–	
Scope / Dependency	scope: local		

Included Containers		
Container Name	Multiplicity	Scope / Dependency
SwCluCOsProxyFunctionDispatcher	0..*	This container configures a function dispatcher. In the Os High Proxy this configuration puts a function as a Dispatch Entry Point in the Binary Manifest which can be called by the Os Low Proxy. In the Os Low Proxy this configuration provides the Dispatcher Function (and according resource Entry in the Binary Manifest) which is able to call the MaxNumberOfCallee Dispatch Entry Points of Os High Proxies. Tags: atp.Status=draft
SwCluCOsProxyOsApplication	0..*	Maps a OsApplication to the CpSoftwareClusterService Resource describing the OsApplication resource in the clustered system. Tags: atp.Status=draft
SwCluCOsProxyOsBaseSocket	0..*	Maps a OsBaseSocket to the CpSoftwareClusterService Resource describing the OsBaseSocket resource in the clustered system. Tags: atp.Status=draft
SwCluCOsProxyOsResource	0..*	Maps a OsResource to the CpSoftwareClusterServiceResource describing the OsResource resource in the clustered system. Tags: atp.Status=draft
SwCluCOsProxyOsSpinlock	0..*	Maps a OsSpinlock to the CpSoftwareClusterServiceResource describing the OsSpinlock resource in the clustered system. Tags: atp.Status=draft
SwCluCOsProxyOsTask	0..*	Maps a OsTask to the CpSoftwareClusterServiceResource describing the OsTask resource in the clustered system. Tags: atp.Status=draft

10.2.7.2.1 Os Proxy Base Socket configuration

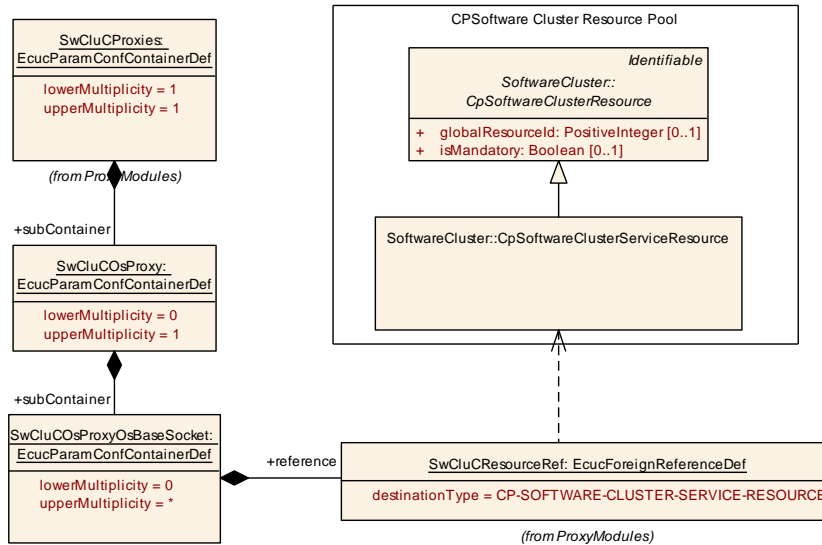

Figure 10.17: Os Proxy Base Socket Parameter

SWS Item	[ECUC_SwCluC_00053]		
Container Name	SwCluCOsProxyOsBaseSocket		
Parent Container	SwCluCOsProxy		
Description	Maps a OsBaseSocket to the CpSoftwareClusterServiceResource describing the Os BaseSocket resource in the clustered system. Tags: atp.Status=draft		
Multiplicity Configuration Class	Pre-compile time	X	All Variants
	Link time	–	
	Post-build time	–	
Configuration Parameters			

SWS Item	[ECUC_SwCluC_00090]		
Parameter Name	SwCluCResourceRef		
Parent Container	SwCluCOsProxyOsBaseSocket		
Description	Reference to the CpSoftwareClusterServiceResource. Tags: atp.Status=draft		
Multiplicity	1		
Type	Foreign reference to CP-SOFTWARE-CLUSTER-SERVICE-RESOURCE		
Scope / Dependency	scope: ECU		

No Included Containers

[SWS_SwCluC_CONSTR_02231][DRAFT] **SwCluCOsProxyOsBaseSocket** relates only to a **CpSoftwareClusterServiceResource** of category **SWCLUSTER_RES_OS_BASE_SOCKET** [The **SwCluCOsProxyOsBaseSocket.SwCluCResourceRef** shall only reference a **CpSoftwareClusterServiceResource** of category **SWCLUSTER_RES_OS_BASE_SOCKET**.]()

10.2.7.2.2 Os Proxy OsApplication configuration

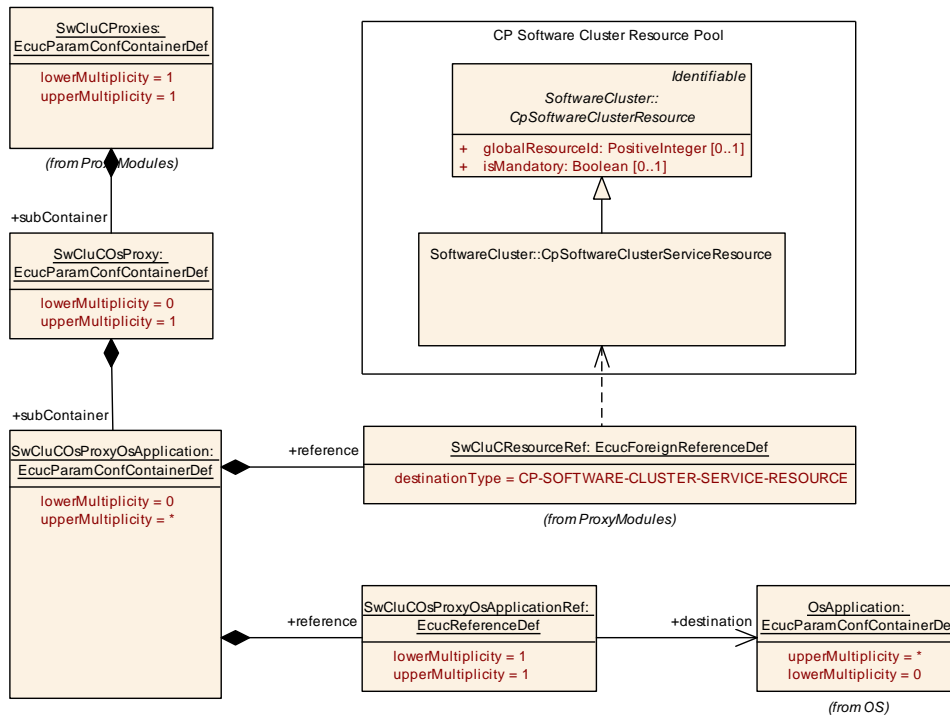

Figure 10.18: Os Proxy OsApplication Parameter

SWS Item	[ECUC_SwCluC_00046]		
Container Name	SwCluCOsProxyOsApplication		
Parent Container	SwCluCOsProxy		
Description	Maps a OsApplication to the CpSoftwareClusterServiceResource describing the Os Application resource in the clustered system. Tags: atp.Status=draft		
Multiplicity Configuration Class	Pre-compile time	X	All Variants
	Link time	-	
	Post-build time	-	
Configuration Parameters			

SWS Item	[ECUC_SwCluC_00050]		
Parameter Name	SwCluCOsProxyOsApplicationRef		
Parent Container	SwCluCOsProxyOsApplication		
Description	Reference to the OsApplication Tags: atp.Status=draft		
Multiplicity	1		
Type	Reference to OsApplication		
Scope / Dependency	scope: ECU		

SWS Item	[ECUC_SwCluC_00088]
Parameter Name	SwCluCResourceRef
Parent Container	SwCluCOsProxyOsApplication
Description	Reference to the CpSoftwareClusterServiceResource. Tags: atp.Status=draft
Multiplicity	1
Type	Foreign reference to CP-SOFTWARE-CLUSTER-SERVICE-RESOURCE
Scope / Dependency	scope: ECU

No Included Containers

[SWS_SwCluC_CONSTR_02232]{DRAFT} **SwCluCOsProxyOsApplication** relates only to a **CpSoftwareClusterServiceResource** of category **SWCLUSTER_RES_OS_APPLICATION** [The `SwCluCOsProxyOsApplication.SwCluCResourceRef` shall only reference a `CpSoftwareClusterServiceResource` of category `SWCLUSTER_RES_OS_APPLICATION`.]()

10.2.7.2.3 Os Proxy OsTask configuration

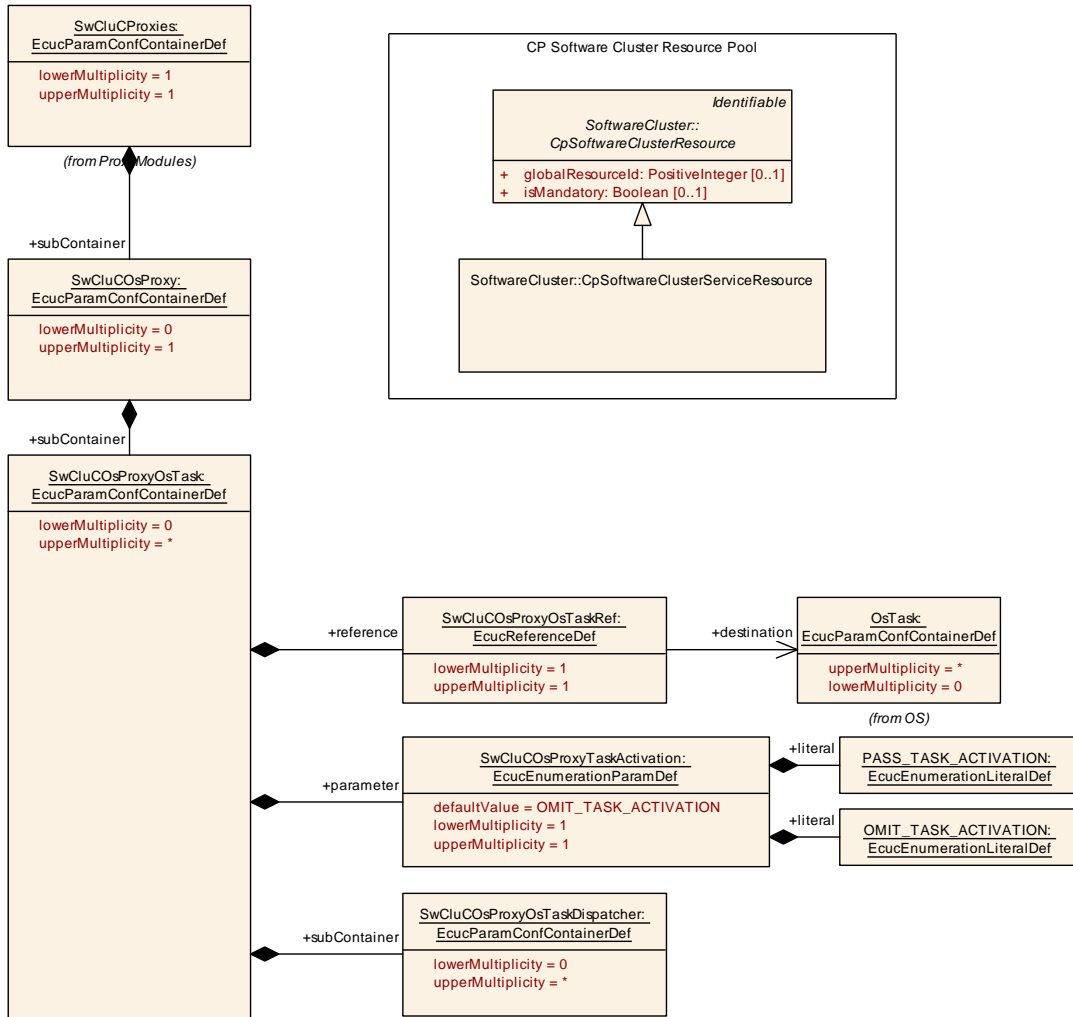

Figure 10.19: Os Proxy OsTask Parameter

SWS Item	[ECUC_SwCluC_00044]		
Container Name	SwCluCOsProxyOsTask		
Parent Container	SwCluCOsProxy		
Description	Maps a OsTask to the CpSoftwareClusterServiceResource describing the OsTask resource in the clustered system. Tags: atp.Status=draft		
Multiplicity Configuration Class	Pre-compile time	X	All Variants
	Link time	–	
	Post-build time	–	
Configuration Parameters			

SWS Item	[ECUC_SwCluC_00048]		
Parameter Name	SwCluCOsProxyTaskActivation		
Parent Container	SwCluCOsProxyOsTask		





Description	Configures for this particular OsTask whether ActivateTask is passed to the Host Software Cluster or not. Tags: atp.Status=draft		
Multiplicity	1		
Type	EcucEnumerationParamDef		
Range	OMIT_TASK_ACTIVATION	ActivateTask is NOT passed to the Host Software Cluster. Tags: atp.Status=draft	
	PASS_TASK_ACTIVATION	ActivateTask is passed to the Host Software Cluster. Tags: atp.Status=draft	
Default value	OMIT_TASK_ACTIVATION		
Multiplicity Configuration Class	Pre-compile time	X	All Variants
	Link time	–	
	Post-build time	–	
Value Configuration Class	Pre-compile time	X	All Variants
	Link time	–	
	Post-build time	–	
Scope / Dependency	scope: ECU		

SWS Item	[ECUC_SwCluC_00045]		
Parameter Name	SwCluCOsProxyOsTaskRef		
Parent Container	SwCluCOsProxyOsTask		
Description	Reference to the OsTask Tags: atp.Status=draft		
Multiplicity	1		
Type	Reference to OsTask		
Scope / Dependency	scope: ECU		

SWS Item	[ECUC_SwCluC_00094]		
Parameter Name	SwCluCResourceRef		
Parent Container	SwCluCOsProxyOsTask		
Description	Reference to the CpSoftwareClusterServiceResource. Tags: atp.Status=draft		
Multiplicity	1		
Type	Foreign reference to CP-SOFTWARE-CLUSTER-SERVICE-RESOURCE		
Scope / Dependency	scope: ECU		

Included Containers		
Container Name	Multiplicity	Scope / Dependency
SwCluCOsProxyOsTaskDispatcher	0..*	<p>This container defines a task dispatcher for the owning proxy task. In the Os High Proxy this configuration provides the OS Task body function as a Dispatch Entry Point in the Binary manifest which can be called by the Os Low Proxy. In the HIGH_PROXY configuration at most one SwCluCOsProxyOsTask Dispatcher can be owned by a SwCluCOsProxyOsTask In the Os Low Proxy this configuration provides the Dispatcher Runnable (and according resource Entry in the Binary Manifest) which is able to call the MaxNumberOfCallee Dispatch Entry Points of Os High Proxies. In the LOW_PROXY configuration multiple SwCluCOsProxyOsTaskDispatcher can be owned by a SwCluCOsProxyOsTask.</p> <p>If none of the SwCluCOsProxyDispatcher<xxx>Event containers is configured it's up to the integrator to model the appropriate RTEEvent.</p> <p>Tags: atp.Status=draft</p>

[SWS_SwCluC_CONSTR_02233]{DRAFT} **SwCluCOsProxyOsTask** relates only to a **CpSoftwareClusterServiceResource** of category **SWCLUSTER_RES_OS_TASK** [The **SwCluCOsProxyOsTask.SwCluCResourceRef** shall only reference a **CpSoftwareClusterServiceResource** of category **SWCLUSTER_RES_OS_TASK**.]()

10.2.7.2.4 Os Proxy OsResource configuration

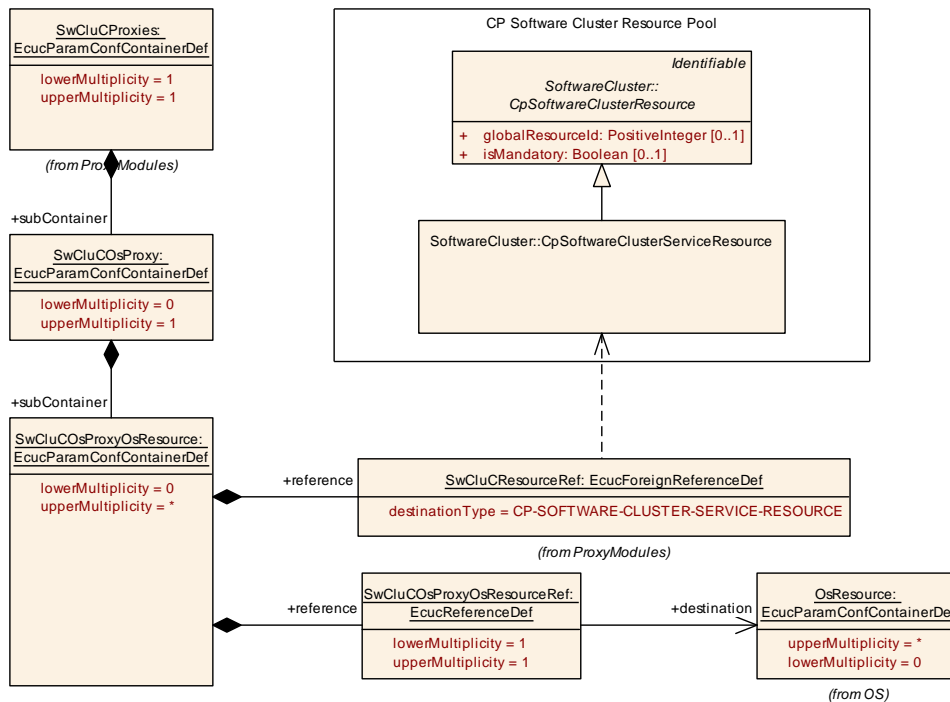

Figure 10.20: Os Proxy OsResource Parameter

SWS Item	[ECUC_SwCluC_00049]		
Container Name	SwCluCOsProxyOsResource		
Parent Container	SwCluCOsProxy		
Description	Maps a OsResource to the CpSoftwareClusterServiceResource describing the Os Resource resource in the clustered system. Tags: atp.Status=draft		
Multiplicity Configuration Class	Pre-compile time	X	All Variants
	Link time	–	
	Post-build time	–	
Configuration Parameters			

SWS Item	[ECUC_SwCluC_00047]		
Parameter Name	SwCluCOsProxyOsResourceRef		
Parent Container	SwCluCOsProxyOsResource		
Description	Reference to the OsResource Tags: atp.Status=draft		
Multiplicity	1		
Type	Reference to OsResource		
Scope / Dependency	scope: ECU		

SWS Item	[ECUC_SwCluC_00087]		
Parameter Name	SwCluCResourceRef		
Parent Container	SwCluCOsProxyOsResource		
Description	Reference to the CpSoftwareClusterServiceResource. Tags: atp.Status=draft		
Multiplicity	1		
Type	Foreign reference to CP-SOFTWARE-CLUSTER-SERVICE-RESOURCE		
Scope / Dependency	scope: ECU		

No Included Containers

[SWS_SwCluC_CONSTR_02234]{DRAFT} [SwCluCOsProxyOsResource](#) relates only to a [CpSoftwareClusterServiceResource](#) of category [SWCLUSTER_RES_OS_RESOURCE](#) [The [SwCluCOsProxyOsResource.SwCluCResourceRef](#) shall only reference a [CpSoftwareClusterServiceResource](#) of category [SWCLUSTER_RES_OS_RESOURCE](#).]()

10.2.7.2.5 Os Proxy OsSpinlock configuration

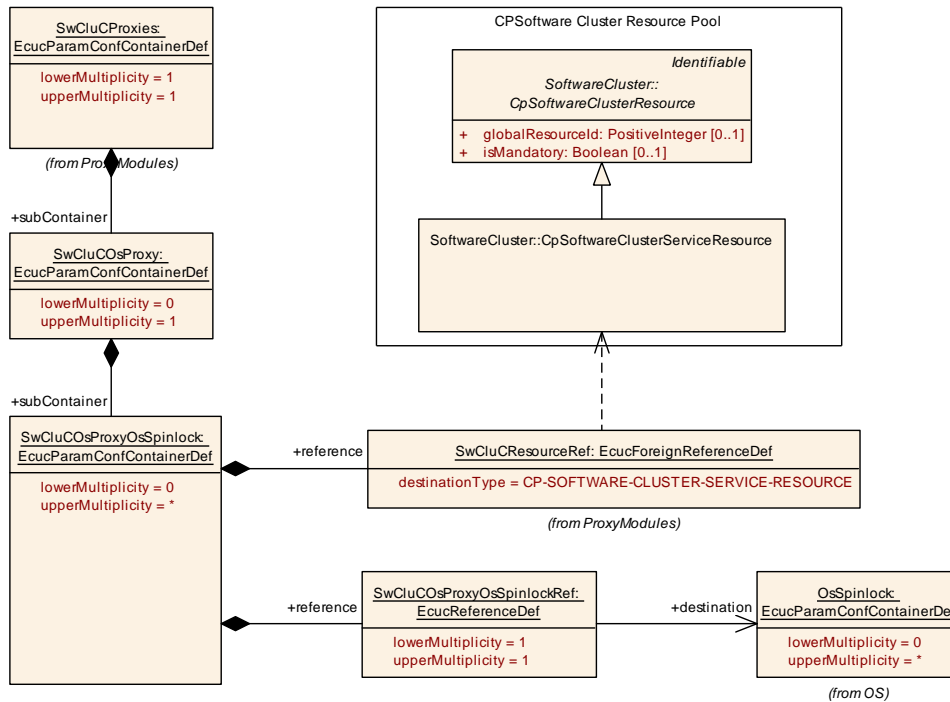

Figure 10.21: Os Proxy OsSpinlock Parameter

SWS Item	[ECUC_SwCluC_00051]		
Container Name	SwCluCOsProxyOsSpinlock		
Parent Container	SwCluCOsProxy		
Description	Maps a OsSpinlock to the CpSoftwareClusterServiceResource describing the Os Spinlock resource in the clustered system. Tags: atp.Status=draft		
Multiplicity Configuration Class	Pre-compile time	X	All Variants
	Link time	–	
	Post-build time	–	
Configuration Parameters			

SWS Item	[ECUC_SwCluC_00052]		
Parameter Name	SwCluCOsProxyOsSpinlockRef		
Parent Container	SwCluCOsProxyOsSpinlock		
Description	Reference to the OsSpinlock Tags: atp.Status=draft		
Multiplicity	1		
Type	Reference to OsSpinlock		
Scope / Dependency	scope: ECU		

SWS Item	[ECUC_SwCluC_00089]
Parameter Name	SwCluCResourceRef
Parent Container	SwCluCOsProxyOsSpinlock
Description	Reference to the CpSoftwareClusterServiceResource. Tags: atp.Status=draft
Multiplicity	1
Type	Foreign reference to CP-SOFTWARE-CLUSTER-SERVICE-RESOURCE
Scope / Dependency	scope: ECU

No Included Containers

[SWS_SwCluC_CONSTR_02235]{DRAFT} **SwCluCOsProxyOsSpinlock** relates only to a **CpSoftwareClusterServiceResource** of category **SWCLUSTER_RES_OS_SPINLOCK** [The **SwCluCOsProxyOsSpinlock.SwCluCResourceRef** shall only reference a **CpSoftwareClusterServiceResource** of category **SWCLUSTER_RES_OS_SPINLOCK**.]()

10.2.7.2.6 Os Proxy Task Dispatcher configuration

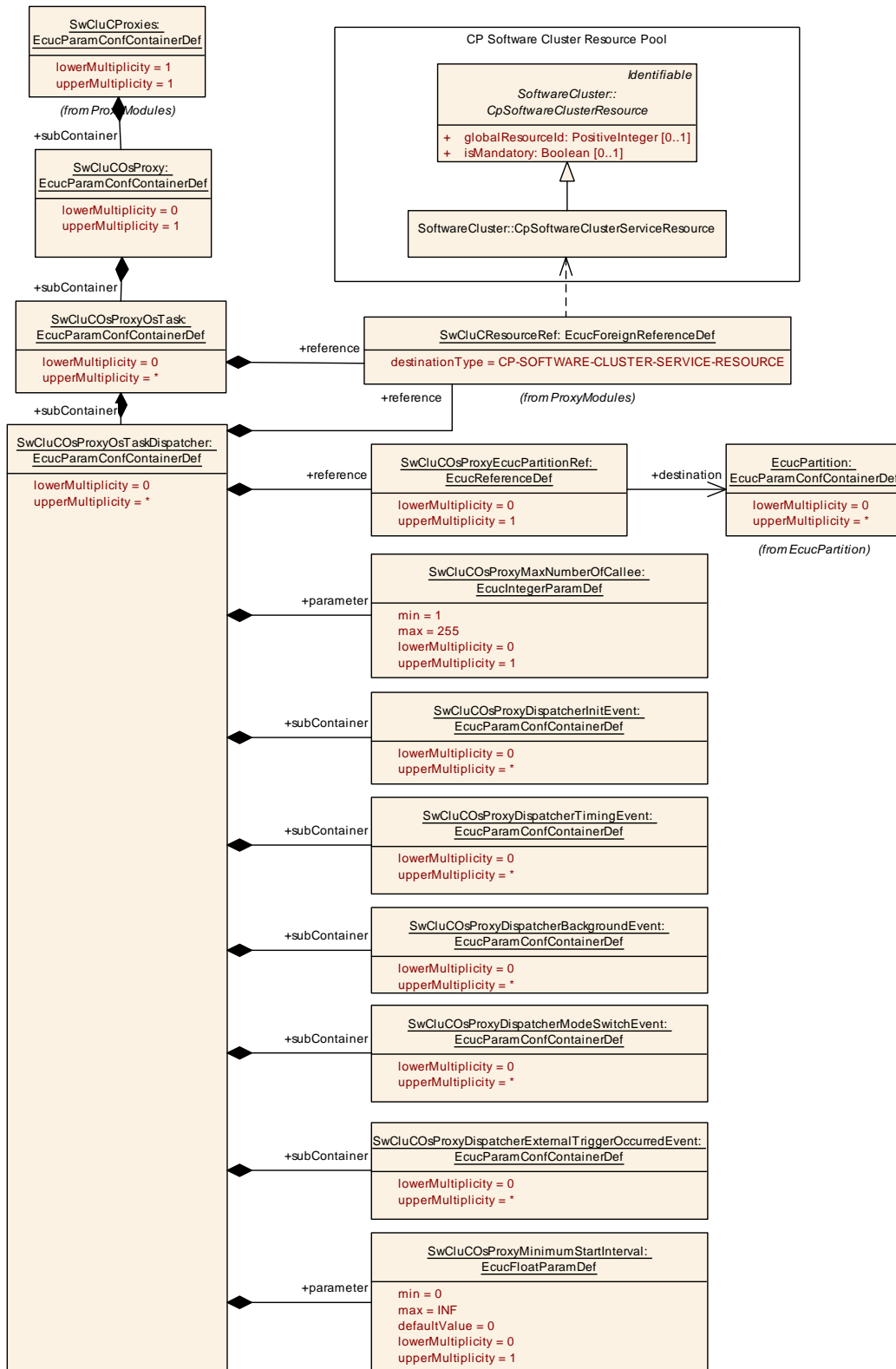

Figure 10.22: Os Proxy Task Dispatcher Parameter

SWS Item	[ECUC_SwCluC_00061]		
Container Name	SwCluCOsProxyOsTaskDispatcher		
Parent Container	SwCluCOsProxyOsTask		
Description	<p>This container defines a task dispatcher for the owning proxy task. In the Os High Proxy this configuration provides the OS Task body function as a Dispatch Entry Point in the Binary manifest which can be called by the Os Low Proxy. In the HIGH_PROXY configuration at most one SwCluCOsProxyOsTaskDispatcher can be owned by a Sw CluCOsProxyOsTask In the Os Low Proxy this configuration provides the Dispatcher Runnable (and according resource Entry in the Binary Manifest) which is able to call the MaxNumberOfCallee Dispatch Entry Points of Os High Proxies. In the LOW_PROXY configuration multiple SwCluCOsProxyOsTaskDispatcher can be owned by a SwCluCOsProxyOsTask.</p> <p>If none of the SwCluCOsProxyDispatcher<xxx>Event containers is configured it's up to the integrator to model the appropriate RTEEvent.</p> <p>Tags: atp.Status=draft</p>		
Multiplicity Configuration Class	Pre-compile time	X	All Variants
	Link time	–	
	Post-build time	–	
Configuration Parameters			

SWS Item	[ECUC_SwCluC_00062]		
Parameter Name	SwCluCOsProxyMaxNumberOfCallee		
Parent Container	SwCluCOsProxyOsTaskDispatcher		
Description	<p>Defines how many Dispatch Entry Points the dispatcher of the Os Low Proxy is able to call at most. In the Os Low Proxy this configuration parameter is mandatory.</p> <p>Tags: atp.Status=draft</p>		
Multiplicity	0..1		
Type	EcucIntegerParamDef		
Range	1 .. 255		
Default value	–		
Scope / Dependency	scope: ECU		

SWS Item	[ECUC_SwCluC_00070]		
Parameter Name	SwCluCOsProxyMinimumStartInterval		
Parent Container	SwCluCOsProxyOsTaskDispatcher		
Description	<p>Specifies the time in seconds by which two consecutive starts of an dispatcher Runnable are guaranteed to be separated.</p> <p>Tags: atp.Status=draft</p>		
Multiplicity	0..1		
Type	EcucFloatParamDef		
Range	[0 .. INF]		
Default value	0		
Scope / Dependency	scope: ECU		

SWS Item	[ECUC_SwCluC_00078]		
Parameter Name	SwCluCOsProxyEcucPartitionRef		
Parent Container	SwCluCOsProxyOsTaskDispatcher		





Description	<p>If the reference is not provided, the task dispatcher is provided on the EcuPartition to which the OsApplication of the OsTask related to the owning SwCluCOsProxyOsTask belongs.</p> <p>If the reference is provided, the task dispatcher is provided on the referenced Ecu Partition. In this case the task dispatcher is scheduled in the OsTask related to the owning SwCluCOsProxyOsTask but is changing its partition before the task dispatcher schedules proxy tasks in the Application Software Cluster.</p> <p>Tags: atp.Status=draft</p>		
Multiplicity	0..1		
Type	Reference to EcucPartition		
Multiplicity Configuration Class	Pre-compile time	X	All Variants
	Link time	–	
	Post-build time	–	
Value Configuration Class	Pre-compile time	X	All Variants
	Link time	–	
	Post-build time	–	
Scope / Dependency	scope: ECU		

SWS Item	[ECUC_SwCluC_00095]
Parameter Name	SwCluCResourceRef
Parent Container	SwCluCOsProxyOsTaskDispatcher
Description	Reference to the CpSoftwareClusterServiceResource. Tags: atp.Status=draft
Multiplicity	1
Type	Foreign reference to CP-SOFTWARE-CLUSTER-SERVICE-RESOURCE
Scope / Dependency	scope: ECU

Included Containers		
Container Name	Multiplicity	Scope / Dependency
SwCluCOsProxyDispatcherBackgroundEvent	0..*	Configures a BackgroundEvent starting the owing Dispatcher Runnable. Tags: atp.Status=draft
SwCluCOsProxyDispatcherExternalTriggerOccurredEvent	0..*	Configures a ExternalTriggerOccurredEvent starting the owing Dispatcher Runnable. Tags: atp.Status=draft
SwCluCOsProxyDispatcherInitEvent	0..*	Configures an InitEvent starting the owing Dispatcher Runnable.
SwCluCOsProxyDispatcherModeSwitchEvent	0..*	Configures a ModeSwitchEvent starting the owing Dispatcher Runnable. Tags: atp.Status=draft
SwCluCOsProxyDispatcherTimingEvent	0..*	Configures a TimingEvent starting the owing Dispatcher Runnable. Tags: atp.Status=draft

[SWS_SwCluC_CONSTR_02236]{DRAFT} [SwCluCOsProxyOsTaskDispatcher](#) relates only to a [CpSoftwareClusterServiceResource](#) of category [SWCLUSTER_RES_OS_TASK_DISPATCHER](#) [The [SwCluCOsProxyOsTaskDispatcher.SwCluCResourceRef](#) shall only reference a [CpSoftwareClusterServiceResource](#) of category [SWCLUSTER_RES_OS_TASK_DISPATCHER](#).]()

10.2.7.2.6.1 Os Proxy Task Dispatcher Timing Event configuration

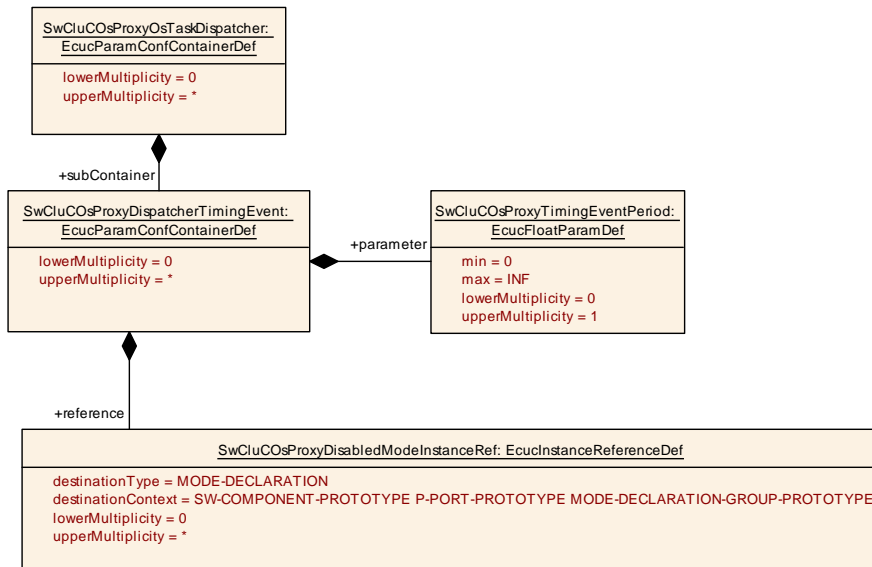

Figure 10.23: Os Proxy Task Dispatcher Timing Event Parameter

SWS Item	[ECUC_SwCluC_00066]		
Container Name	SwCluCOsProxyDispatcherTimingEvent		
Parent Container	SwCluCOsProxyOsTaskDispatcher		
Description	Configures a TimingEvent starting the owing Dispatcher Runnable. Tags: atp.Status=draft		
Multiplicity Configuration Class	Pre-compile time	X	All Variants
	Link time	–	
	Post-build time	–	
Configuration Parameters			

SWS Item	[ECUC_SwCluC_00065]		
Parameter Name	SwCluCOsProxyTimingEventPeriod		
Parent Container	SwCluCOsProxyDispatcherTimingEvent		
Description	Period of timing event in seconds. The value of this attribute shall be greater than zero. Tags: atp.Status=draft		
Multiplicity	0..1		
Type	EcucFloatParamDef		
Range	[0 .. INF]		
Default value	–		
Scope / Dependency	scope: ECU		

SWS Item	[ECUC_SwCluC_00071]		
Parameter Name	SwCluCOsProxyDisabledModeInstanceRef		
Parent Container	SwCluCOsProxyDispatcherTimingEvent		





Description	Reference to the Mode instance in a PPortPrototype that disable the Event. Tags: atp.Status=draft
Multiplicity	0..*
Type	Instance reference to MODE-DECLARATION context: SW-COMPONENT-PROTOTYPE P-PORT-PROTOTYPE MODE-DECLARATION-GROUP-PROTOTYPE
Scope / Dependency	scope: ECU

No Included Containers

10.2.7.2.6.2 Os Proxy Task Dispatcher Background Event configuration

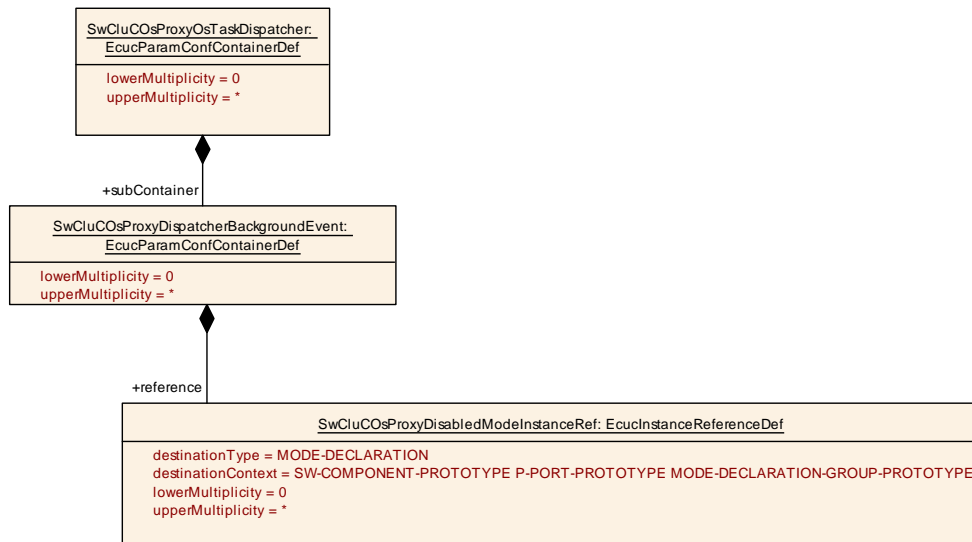

Figure 10.24: Os Proxy Task Dispatcher Background Event Parameter

SWS Item	[ECUC_SwCluC_00067]		
Container Name	SwCluCOsProxyDispatcherBackgroundEvent		
Parent Container	SwCluCOsProxyOsTaskDispatcher		
Description	Configures a BackgroundEvent starting the owing Dispatcher Runnable. Tags: atp.Status=draft		
Multiplicity Configuration Class	Pre-compile time	X	All Variants
	Link time	–	
	Post-build time	–	
Configuration Parameters			

SWS Item	[ECUC_SwCluC_00071]		
Parameter Name	SwCluCOsProxyDisabledModeInstanceRef		
Parent Container	SwCluCOsProxyDispatcherBackgroundEvent		





Description	Reference to the Mode instance in a PPortPrototype that disable the Event. Tags: atp.Status=draft
Multiplicity	0..*
Type	Instance reference to MODE-DECLARATION context: SW-COMPONENT-PROTOTYPE P-PORT-PROTOTYPE MODE-DECLARATION-GROUP-PROTOTYPE
Scope / Dependency	scope: ECU

No Included Containers

10.2.7.2.6.3 Os Proxy Task Dispatcher Init Event configuration

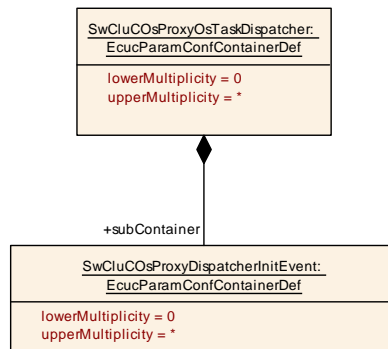

Figure 10.25: Os Proxy Task Dispatcher Init Event Parameter

SWS Item	[ECUC_SwCluC_00153]		
Container Name	SwCluCOsProxyDispatcherInitEvent		
Parent Container	SwCluCOsProxyOsTaskDispatcher		
Description	Configures an InitEvent starting the owing Dispatcher Runnable.		
Post-Build Variant Multiplicity	false		
Multiplicity Configuration Class	Pre-compile time	X	All Variants
	Link time	-	
	Post-build time	-	
Configuration Parameters			

No Included Containers

10.2.7.2.6.4 Os Proxy Task Dispatcher Mode Switch Event configuration

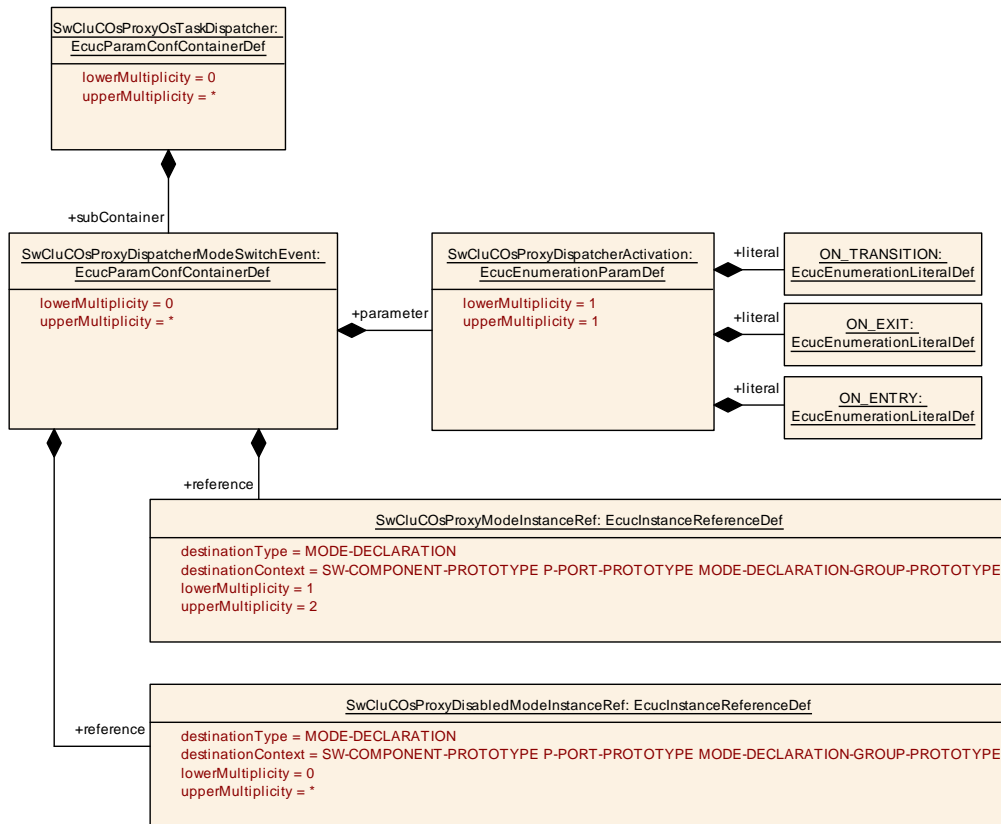

Figure 10.26: Os Proxy Task Dispatcher Mode Switch Event Parameter

SWS Item	[ECUC_SwCluC_00068]		
Container Name	SwCluCOsProxyDispatcherModeSwitchEvent		
Parent Container	SwCluCOsProxyOsTaskDispatcher		
Description	Configures a ModeSwitchEvent starting the owing Dispatcher Runnable. Tags: atp.Status=draft		
Multiplicity Configuration Class	Pre-compile time	X	All Variants
	Link time	–	
	Post-build time	–	
Configuration Parameters			

SWS Item	[ECUC_SwCluC_00072]		
Parameter Name	SwCluCOsProxyDispatcherActivation		
Parent Container	SwCluCOsProxyDispatcherModeSwitchEvent		
Description	Specifies if the event is activated on entering or exiting the referenced Mode instance. Tags: atp.Status=draft		
Multiplicity	1		
Type	EcucEnumerationParamDef		
Range	ON_ENTRY	On entering the referred mode.	
	ON_EXIT	On exiting the referred mode.	





	ON_TRANSITION	On transition of the 1st referred mode to the 2nd referred mode.	
Multiplicity Configuration Class	Pre-compile time	X	All Variants
	Link time	–	
	Post-build time	–	
Value Configuration Class	Pre-compile time	X	All Variants
	Link time	–	
	Post-build time	–	
Scope / Dependency	scope: ECU		

SWS Item	[ECUC_SwCluC_00071]
Parameter Name	SwCluCOsProxyDisabledModeInstanceRef
Parent Container	SwCluCOsProxyDispatcherModeSwitchEvent
Description	Reference to the Mode instance in a PPortPrototype that disable the Event. Tags: atp.Status=draft
Multiplicity	0..*
Type	Instance reference to MODE-DECLARATION context: SW-COMPONENT-PROTOTYPE P-PORT-PROTOTYPE MODE-DECLARATION-GROUP-PROTOTYPE
Scope / Dependency	scope: ECU

SWS Item	[ECUC_SwCluC_00073]
Parameter Name	SwCluCOsProxyModeInstanceRef
Parent Container	SwCluCOsProxyDispatcherModeSwitchEvent
Description	Reference to one or two Mode instances in a PPortPrototype that that initiate the mode switch. Tags: atp.Status=draft
Multiplicity	1..2
Type	Instance reference to MODE-DECLARATION context: SW-COMPONENT-PROTOTYPE P-PORT-PROTOTYPE MODE-DECLARATION-GROUP-PROTOTYPE
Scope / Dependency	scope: ECU

No Included Containers

10.2.7.2.6.5 Os Proxy Task Dispatcher External Trigger Occurred Event configuration

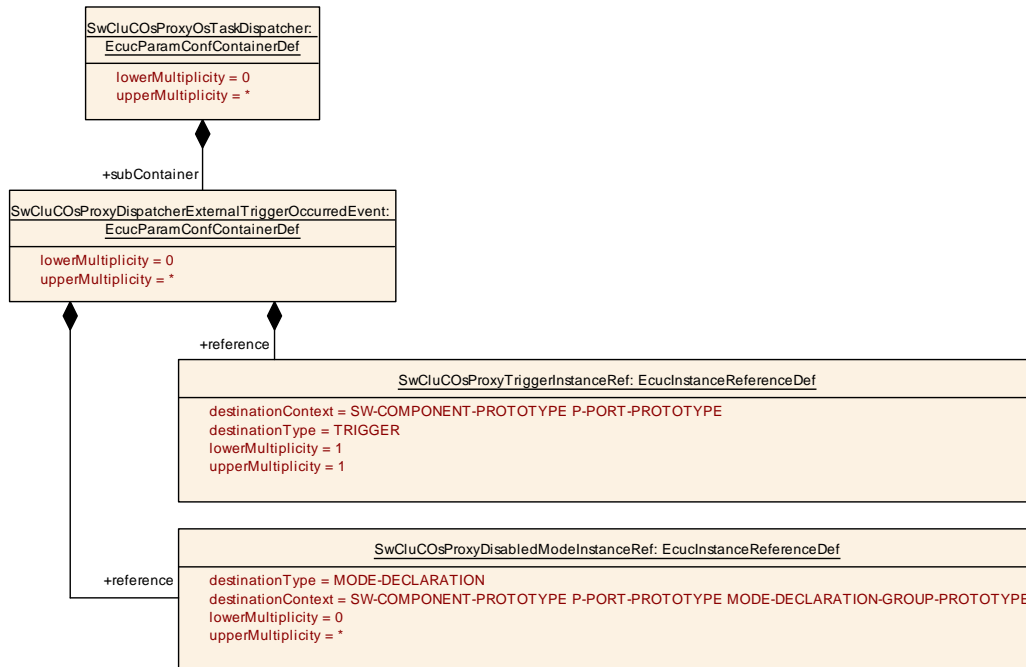

Figure 10.27: Os Proxy Task Dispatcher External Trigger Occurred Event Parameter

SWS Item	[ECUC_SwCluC_00069]		
Container Name	SwCluCOsProxyDispatcherExternalTriggerOccurredEvent		
Parent Container	SwCluCOsProxyOsTaskDispatcher		
Description	Configures a ExternalTriggerOccurredEvent starting the owing Dispatcher Runnable. Tags: atp.Status=draft		
Multiplicity Configuration Class	Pre-compile time	X	All Variants
	Link time	–	
	Post-build time	–	
Configuration Parameters			

SWS Item	[ECUC_SwCluC_00071]		
Parameter Name	SwCluCOsProxyDisabledModelInstanceRef		
Parent Container	SwCluCOsProxyDispatcherExternalTriggerOccurredEvent		
Description	Reference to the Mode instance in a PPortPrototype that disable the Event. Tags: atp.Status=draft		
Multiplicity	0..*		
Type	Instance reference to MODE-DECLARATION context: SW-COMPONENT-PROTOTYPE P-PORT-PROTOTYPE MODE-DECLARATION-GROUP-PROTOTYPE		
Scope / Dependency	scope: ECU		

SWS Item	[ECUC_SwCluC_00074]
Parameter Name	SwCluCOsProxyTriggerInstanceRef
Parent Container	SwCluCOsProxyDispatcherExternalTriggerOccurredEvent
Description	Reference to the Trigger instances in a PPortPrototype that raise the trigger. Tags: atp.Status=draft
Multiplicity	1
Type	Instance reference to TRIGGER context: SW-COMPONENT-PROTOTYPE P-PORT-PROTOTYPE
Scope / Dependency	scope: ECU

No Included Containers

10.2.7.2.7 Os Proxy Function Dispatcher configuration

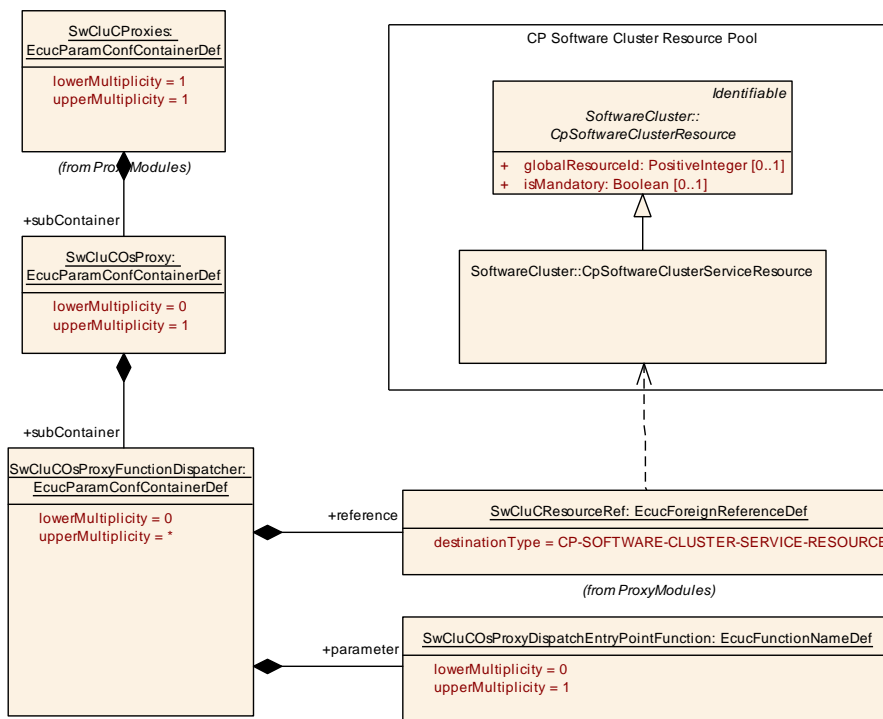

Figure 10.28: Os Proxy Function Dispatcher Parameter

SWS Item	[ECUC_SwCluC_00063]
Container Name	SwCluCOsProxyFunctionDispatcher
Parent Container	SwCluCOsProxy





Description	This container configures a function dispatcher. In the Os High Proxy this configuration puts a function as a Dispatch Entry Point in the Binary Manifest which can be called by the Os Low Proxy. In the Os Low Proxy this configuration provides the Dispatcher Function (and according resource Entry in the Binary Manifest) which is able to call the MaxNumberOfCallee Dispatch Entry Points of Os High Proxies. Tags: atp.Status=draft		
Multiplicity Configuration Class	Pre-compile time	X	All Variants
	Link time	–	
	Post-build time	–	
Configuration Parameters			

SWS Item	[ECUC_SwCluC_00064]		
Parameter Name	SwCluCOsProxyDispatchEntryPointFunction		
Parent Container	SwCluCOsProxyFunctionDispatcher		
Description	Name of the function which is put into the Binary Manifest as Dispatch Entry Point. In the Os High Proxy this configuration parameter is mandatory Tags: atp.Status=draft		
Multiplicity	0..1		
Type	EcucFunctionNameDef		
Default value	–		
Regular Expression	–		
Multiplicity Configuration Class	Pre-compile time	X	All Variants
	Link time	–	
	Post-build time	–	
Value Configuration Class	Pre-compile time	X	All Variants
	Link time	–	
	Post-build time	–	
Scope / Dependency	scope: ECU		

SWS Item	[ECUC_SwCluC_00097]		
Parameter Name	SwCluCResourceRef		
Parent Container	SwCluCOsProxyFunctionDispatcher		
Description	Reference to the CpSoftwareClusterServiceResource. Tags: atp.Status=draft		
Multiplicity	1		
Type	Foreign reference to CP-SOFTWARE-CLUSTER-SERVICE-RESOURCE		
Scope / Dependency	scope: ECU		

No Included Containers

[SWS_SwCluC_CONSTR_02237]{DRAFT} [SwCluCOsProxyFunctionDispatcher](#) relates only to a [CpSoftwareClusterServiceResource](#) of category [SWCLUSTER_RES_OS_FNC_DISPATCHER](#) [The [SwCluCOsProxyFunctionDispatcher.SwCluCResourceRef](#) shall only reference a [CpSoftwareClusterServiceResource](#) of category [SWCLUSTER_RES_OS_FNC_DISPATCHER](#).]()

10.2.7.3 Com Proxy

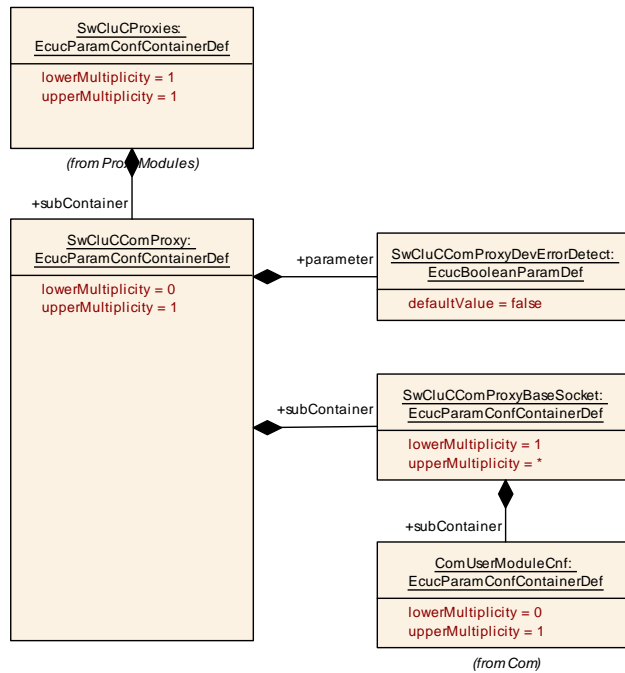

Figure 10.29: Com Proxy Parameter

SWS Item	[ECUC_SwCluC_00127]		
Container Name	SwCluCComProxy		
Parent Container	SwCluCProxies		
Description	LdCom Proxy specific parameters. Tags: atp.Status=draft		
Multiplicity Configuration Class	Pre-compile time	X	All Variants
	Link time	–	
	Post-build time	–	
Configuration Parameters			

SWS Item	[ECUC_SwCluC_00128]		
Parameter Name	SwCluCComProxyDevErrorDetect		
Parent Container	SwCluCComProxy		
Description	Switches the development error detection and notification on or off. <ul style="list-style-type: none"> • true: detection and notification is enabled. • false: detection and notification is disabled. Tags: atp.Status=draft		
Multiplicity	1		
Type	EcucBooleanParamDef		
Default value	false		
Post-Build Variant Value	false		
Value Configuration Class	Pre-compile time	X	All Variants
	Link time	–	





	Post-build time	-	
Scope / Dependency	scope: local		

Included Containers		
Container Name	Multiplicity	Scope / Dependency
SwCluCComProxyBaseSocket	1..*	<p>This container configures how many EcucPartitions specific API links are required for the Com Proxy and to which cluster resource the API set belongs.</p> <p>In the Com Low Proxy all offered API sets (incl callbacks) needs to be configured. In the Com High Proxy only the ones are configured which are offered inside this Application Software Cluster.</p> <p>The reference SwCluCProxyEcucPartitionRef denotes the Ecuc Partition on which the API set is provided.</p> <p>The ComUserModuleCnf is only applicable in the Host Software Cluster and shall not be configured in the scope of a Application Software Cluster. One ComUserModuleCnf instance can either server for ComSignals and ComSignalGroups on multiple Ecuc Partitions or exactly one EcucPartition. How many ComUser instances an Rte in an related Application Software Cluster requires is vendor specific.</p> <p>Tags: atp.Status=draft</p>

10.2.7.3.1 Com Proxy Base Socket

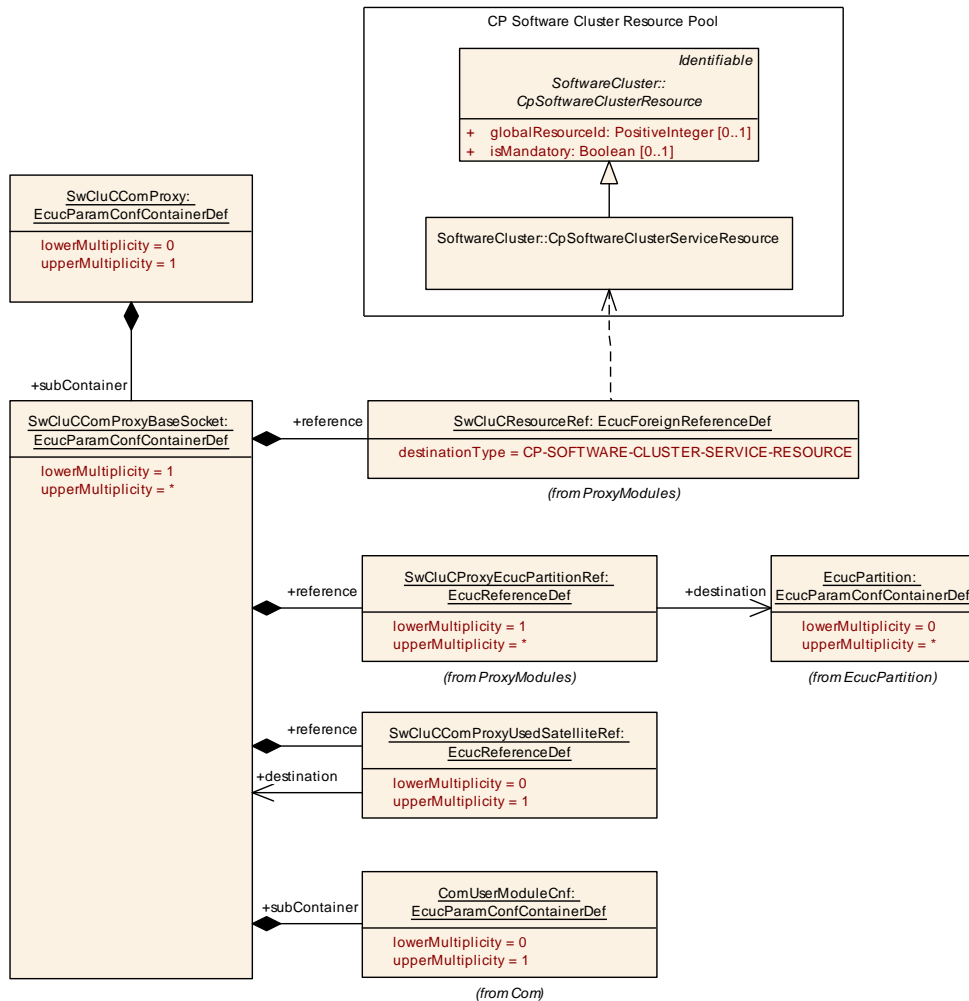

Figure 10.30: Com Proxy Base Socket

SWS Item	[ECUC_SwCluC_00131]
Container Name	SwCluCComProxyBaseSocket
Parent Container	SwCluCComProxy
Description	<p>This container configures how many EcucPartitions specific API links are required for the Com Proxy and to which cluster resource the API set belongs.</p> <p>In the Com Low Proxy all offered API sets (incl callbacks) needs to be configured. In the Com High Proxy only the ones are configured which are offered inside this Application Software Cluster.</p> <p>The reference SwCluCProxyEcucPartitionRef denotes the EcucPartition on which the API set is provided.</p> <p>The ComUserModuleCnf is only applicable in the Host Software Cluster and shall not be configured in the scope of a Application Software Cluster. One ComUserModuleCnf instance can either server for ComSignals and ComSignalGroups on multiple Ecuc Partitions or exactly one EcucPartition. How many ComUser instances an Rte in an related Application Software Cluster requires is vendor specific.</p> <p>Tags: atp.Status=draft</p>





Multiplicity Configuration Class	Pre-compile time	X	All Variants
	Link time	–	
	Post-build time	–	
Configuration Parameters			

SWS Item	[ECUC_SwCluC_00132]		
Parameter Name	SwCluCComProxyUsedSatelliteRef		
Parent Container	SwCluCComProxyBaseSocket		
Description	Reference to the SwCluCComBaseSocket which has access to a satellite of the Com. The owning SwCluCComBaseSocket uses the Com satellite of the referenced SwCluCComBaseSocket. Tags: atp.Status=draft		
Multiplicity	0..1		
Type	Reference to SwCluCComProxyBaseSocket		
Multiplicity Configuration Class	Pre-compile time	X	All Variants
	Link time	–	
	Post-build time	–	
Value Configuration Class	Pre-compile time	X	All Variants
	Link time	–	
	Post-build time	–	
Scope / Dependency	scope: ECU		

SWS Item	[ECUC_SwCluC_00147]		
Parameter Name	SwCluCProxyEcucPartitionRef		
Parent Container	SwCluCComProxyBaseSocket		
Description	Reference to the EcucPartition. Tags: atp.Status=draft		
Multiplicity	1..*		
Type	Reference to EcucPartition		
Multiplicity Configuration Class	Pre-compile time	X	All Variants
	Link time	–	
	Post-build time	–	
Value Configuration Class	Pre-compile time	X	All Variants
	Link time	–	
	Post-build time	–	
Scope / Dependency	scope: ECU		

SWS Item	[ECUC_SwCluC_00148]		
Parameter Name	SwCluCResourceRef		
Parent Container	SwCluCComProxyBaseSocket		
Description	Reference to the CpSoftwareClusterServiceResource. Tags: atp.Status=draft		
Multiplicity	1		
Type	Foreign reference to CP-SOFTWARE-CLUSTER-SERVICE-RESOURCE		
Scope / Dependency	scope: ECU		

Included Containers		
Container Name	Multiplicity	Scope / Dependency
ComUserModuleCnf	0..1	Contains the configuration parameters of the Com user module. Tags: atp.Status=draft

[SWS_SwCluC_CONSTR_02664]{DRAFT} SwCluCComProxyBaseSocket relates only to a CpSoftwareClusterServiceResource of category SWCLUSTER_RES_COM_BASE_SOCKET [The SwCluCComProxyBaseSocket.SwCluCResourceRef shall only reference a CpSoftwareClusterServiceResource of category SWCLUSTER_RES_COM_BASE_SOCKET.]()

10.2.7.3.2 Com User Module Configuration

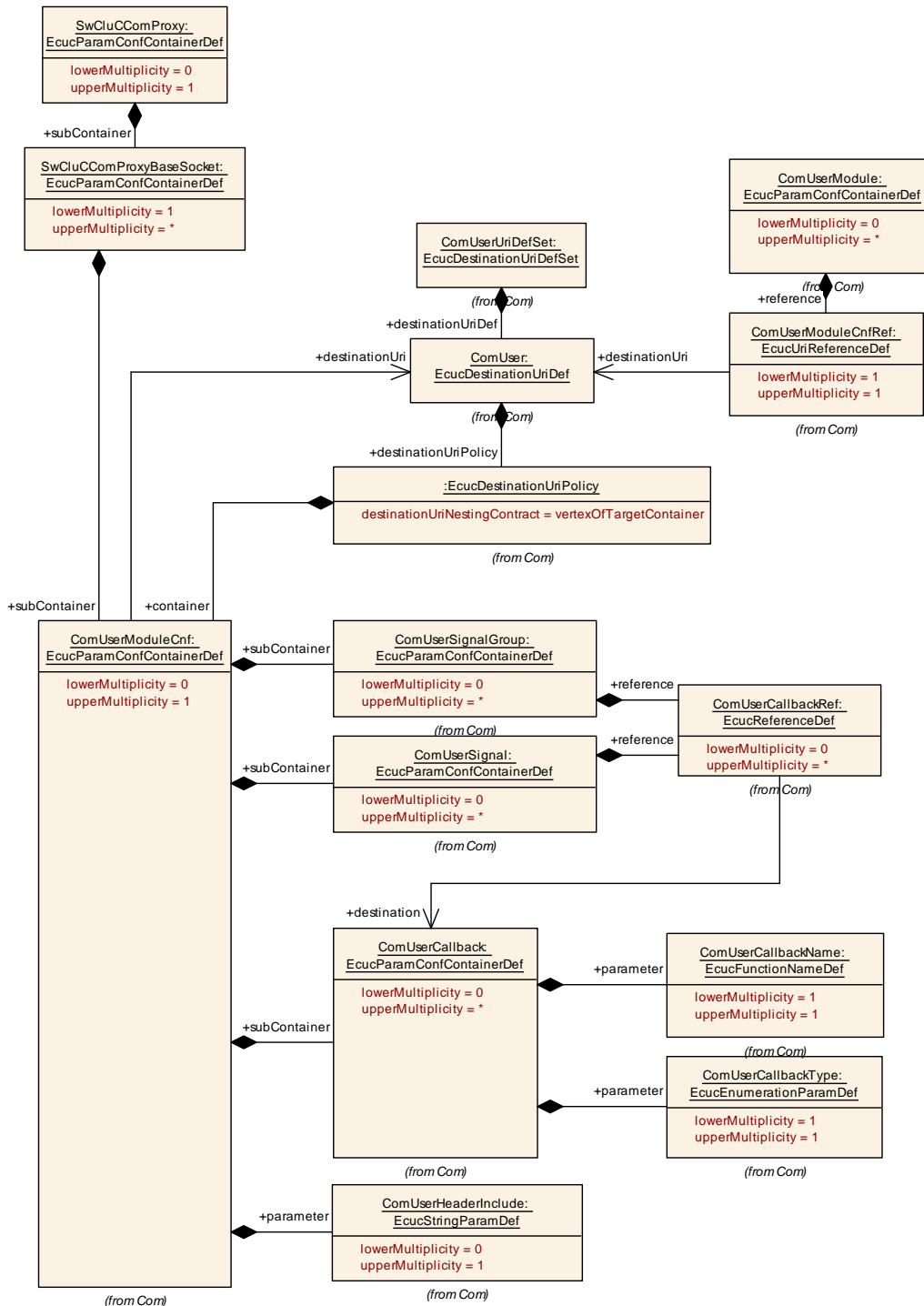

Figure 10.31: Com user module configuration

SWS Item	[ECUC_Com_10030]		
Container Name	ComUserModuleCnf		
Parent Container	RteComUser, SwCluCComProxyBaseSocket		
Destination Uri Definition	ComUser		
Description	Contains the configuration parameters of the Com user module. Tags: atp.Status=draft		
Post-Build Variant Multiplicity	false		
Multiplicity Configuration Class	Pre-compile time	X	All Variants
	Link time	–	
	Post-build time	–	
Configuration Parameters			

SWS Item	[ECUC_Com_10032]		
Parameter Name	ComUserHeaderInclude		
Parent Container	ComUserModuleCnf		
Description	Defines the header file where the Com user provides the function declarations for configured callbacks. Tags: atp.Status=draft		
Multiplicity	0..1		
Type	EcucStringParamDef		
Default value	–		
Regular Expression	–		
Post-Build Variant Value	false		
Value Configuration Class	Pre-compile time	X	All Variants
	Link time	–	
	Post-build time	–	
Scope / Dependency	scope: local		

Included Containers		
Container Name	Multiplicity	Scope / Dependency
ComUserCallback	0..*	This container defines a Com callback function for signals and signal groups. Tags: atp.Status=draft
ComUserSignal	0..*	Contains the configuration parameters of a signal inside a Com user module. Please note that it is valid to define ComUser Signal without any callback function. Tags: atp.Status=draft
ComUserSignalGroup	0..*	Contains the configuration parameters of a signal group inside a Com user module. Please note that it is valid to define ComUser SignalGroup without any callback function. Tags: atp.Status=draft

10.2.7.3.3 Com User Signals and Signal Groups

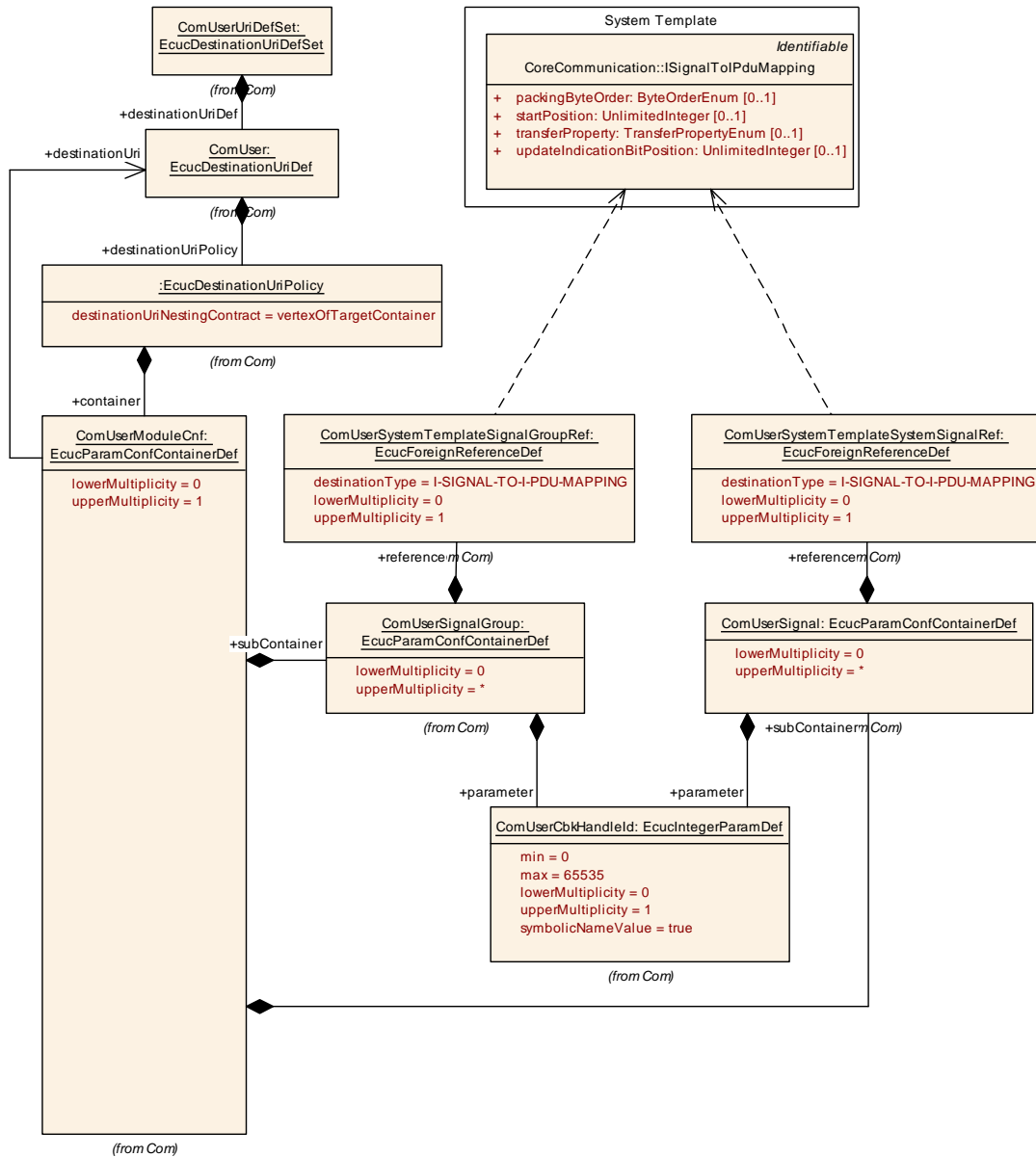

Figure 10.32: Com user signals and signal groups

10.2.7.3.3.1 Com User Signals

SWS Item	[ECUC_Com_10028]
Container Name	ComUserSignal
Parent Container	ComUserModuleCnf





Description	Contains the configuration parameters of a signal inside a Com user module. Please note that it is valid to define ComUserSignal without any callback function. Tags: atp.Status=draft		
Post-Build Variant Multiplicity	true		
Multiplicity Configuration Class	Pre-compile time	X	VARIANT-PRE-COMPILE
	Link time	–	
	Post-build time	X	VARIANT-POST-BUILD
Configuration Parameters			

SWS Item	[ECUC_Com_10033]		
Parameter Name	ComUserCbkJd		
Parent Container	ComUserSignal		
Description	The numerical value used as the Com user callback handle Id. This ID identifies signals and signal groups in the COM callbacks using ComUserCbkJd parameter respectively. Tags: atp.Status=draft		
Multiplicity	0..1		
Type	EcucIntegerParamDef (Symbolic Name generated for this parameter)		
Range	0 .. 65535		
Default value	–		
Post-Build Variant Multiplicity	false		
Post-Build Variant Value	false		
Multiplicity Configuration Class	Pre-compile time	X	All Variants
	Link time	–	
	Post-build time	–	
Value Configuration Class	Pre-compile time	X	All Variants
	Link time	–	
	Post-build time	–	
Scope / Dependency	scope: ECU		

SWS Item	[ECUC_Com_10035]		
Parameter Name	ComUserCallbackRef		
Parent Container	ComUserSignal		
Description	Reference(s) to all callback(s) of this signal or signal group. Tags: atp.Status=draft		
Multiplicity	0..*		
Type	Reference to ComUserCallback		
Post-Build Variant Multiplicity	true		
Post-Build Variant Value	true		
Multiplicity Configuration Class	Pre-compile time	X	VARIANT-PRE-COMPILE
	Link time	–	
	Post-build time	X	VARIANT-POST-BUILD
Value Configuration Class	Pre-compile time	X	VARIANT-PRE-COMPILE
	Link time	X	VARIANT-POST-BUILD
	Post-build time	–	
Scope / Dependency	scope: ECU		

SWS Item	[ECUC_Com_10025]		
Parameter Name	ComUserSystemTemplateSystemSignalRef		
Parent Container	ComUserSignal		
Description	Reference to the ISignalToIPduMapping that contains a reference to the ISignal (System Template) which this ComUserSignal (or ComUserGroupSignal) represents. Tags: atp.Status=draft		
Multiplicity	0..1		
Type	Foreign reference to I-SIGNAL-TO-I-PDU-MAPPING		
Post-Build Variant Multiplicity	true		
Post-Build Variant Value	true		
Multiplicity Configuration Class	Pre-compile time	X	VARIANT-PRE-COMPILE
	Link time	–	
	Post-build time	X	VARIANT-POST-BUILD
Value Configuration Class	Pre-compile time	X	VARIANT-PRE-COMPILE
	Link time	–	
	Post-build time	X	VARIANT-POST-BUILD
Scope / Dependency	scope: ECU		

No Included Containers

10.2.7.3.3.2 Com User Signal Groups

SWS Item	[ECUC_Com_10027]		
Container Name	ComUserSignalGroup		
Parent Container	ComUserModuleCnf		
Description	Contains the configuration parameters of a signal group inside a Com user module. Please note that it is valid to define ComUserSignalGroup without any callback function. Tags: atp.Status=draft		
Post-Build Variant Multiplicity	true		
Multiplicity Configuration Class	Pre-compile time	X	VARIANT-PRE-COMPILE
	Link time	–	
	Post-build time	X	VARIANT-POST-BUILD
Configuration Parameters			

SWS Item	[ECUC_Com_10033]		
Parameter Name	ComUserCbkJd		
Parent Container	ComUserSignalGroup		
Description	The numerical value used as the Com user callback handle Id. This ID identifies signals and signal groups in the COM callbacks using ComUserCbkJd parameter respectively. Tags: atp.Status=draft		
Multiplicity	0..1		
Type	EcucIntegerParamDef (Symbolic Name generated for this parameter)		
Range	0 .. 65535		





Default value	-		
Post-Build Variant Multiplicity	false		
Post-Build Variant Value	false		
Multiplicity Configuration Class	Pre-compile time	X	All Variants
	Link time	-	
	Post-build time	-	
Value Configuration Class	Pre-compile time	X	All Variants
	Link time	-	
	Post-build time	-	
Scope / Dependency	scope: ECU		

SWS Item	[ECUC_Com_10035]		
Parameter Name	ComUserCallbackRef		
Parent Container	ComUserSignalGroup		
Description	Reference(s) to all callback(s) of this signal or signal group. Tags: atp.Status=draft		
Multiplicity	0..*		
Type	Reference to ComUserCallback		
Post-Build Variant Multiplicity	true		
Post-Build Variant Value	true		
Multiplicity Configuration Class	Pre-compile time	X	VARIANT-PRE-COMPILE
	Link time	-	
	Post-build time	X	VARIANT-POST-BUILD
Value Configuration Class	Pre-compile time	X	VARIANT-PRE-COMPILE
	Link time	X	VARIANT-POST-BUILD
	Post-build time	-	
Scope / Dependency	scope: ECU		

SWS Item	[ECUC_Com_10026]		
Parameter Name	ComUserSystemTemplateSignalGroupRef		
Parent Container	ComUserSignalGroup		
Description	Reference to the ISignalToIPduMapping that contains a reference to the ISignalGroup (SystemTemplate) which this ComUserSignalGroup represents. Tags: atp.Status=draft		
Multiplicity	0..1		
Type	Foreign reference to I-SIGNAL-TO-I-PDU-MAPPING		
Post-Build Variant Multiplicity	true		
Post-Build Variant Value	true		
Multiplicity Configuration Class	Pre-compile time	X	VARIANT-PRE-COMPILE
	Link time	-	
	Post-build time	X	VARIANT-POST-BUILD
Value Configuration Class	Pre-compile time	X	VARIANT-PRE-COMPILE
	Link time	-	
	Post-build time	X	VARIANT-POST-BUILD
Scope / Dependency	scope: ECU		

No Included Containers

10.2.7.3.4 Com User callbacks

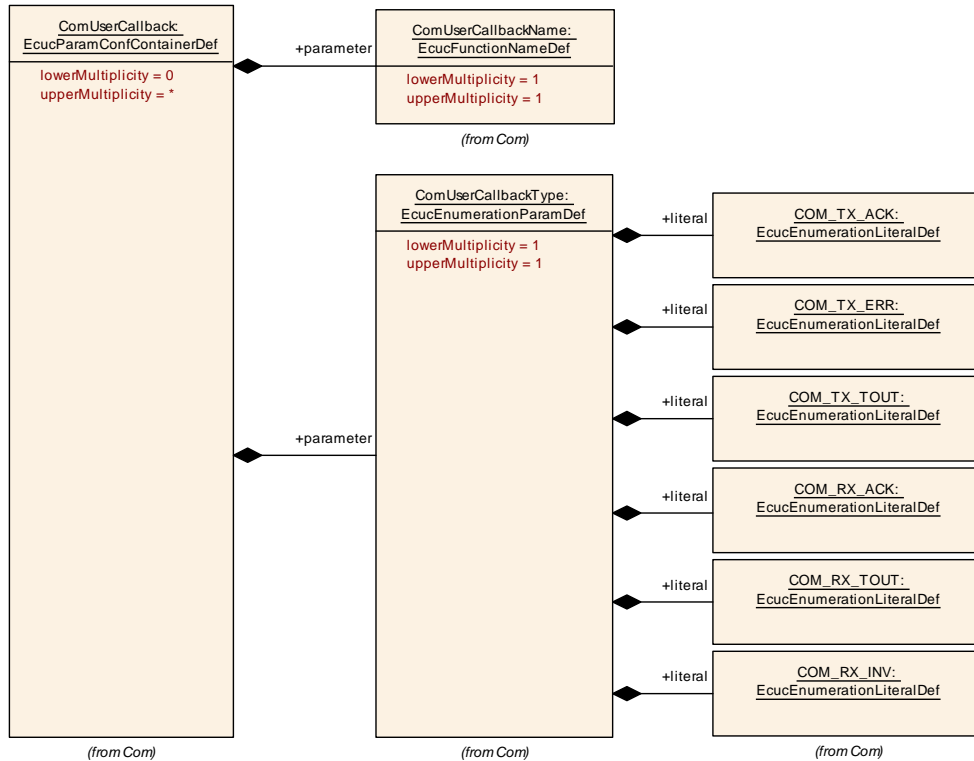

Figure 10.33: Com User callbacks

SWS Item	[ECUC_Com_10038]		
Container Name	ComUserCallback		
Parent Container	ComUserModuleCnf		
Description	This container defines a Com callback function for signals and signal groups. Tags: atp.Status=draft		
Post-Build Variant Multiplicity	true		
Multiplicity Configuration Class	Pre-compile time	X	VARIANT-PRE-COMPILE
	Link time	X	VARIANT-POST-BUILD
	Post-build time	–	
Configuration Parameters			

SWS Item	[ECUC_Com_10036]		
Parameter Name	ComUserCallbackName		
Parent Container	ComUserCallback		
Description	The name of the callback function to be called. Tags: atp.Status=draft		
Multiplicity	1		
Type	EcucFunctionNameDef		
Default value	–		
Regular Expression	–		
Post-Build Variant Multiplicity	false		





Post-Build Variant Value	false		
Multiplicity Configuration Class	Pre-compile time	X	VARIANT-PRE-COMPILE
	Link time	X	VARIANT-POST-BUILD
	Post-build time	–	
Value Configuration Class	Pre-compile time	X	VARIANT-PRE-COMPILE
	Link time	X	VARIANT-POST-BUILD
	Post-build time	–	
Scope / Dependency	scope: ECU		

SWS Item	[ECUC_Com_10034]		
Parameter Name	ComUserCallbackType		
Parent Container	ComUserCallback		
Description	The type of the Com callback Tags: atp.Status=draft		
Multiplicity	1		
Type	EcucEnumerationParamDef		
Range	COM_RX_ACK	Com_CbkRxAck callback which is called immediately after the message has been stored in the receiving message object. This type of callback represents a ComNotification. Tags: atp.Status=draft	
	COM_RX_INV	Com_CbkInv callback which is called after reception of an invalid signal or signal group respectively. This type of callback represents a ComInvalidNotification. Tags: atp.Status=draft	
	COM_RX_TOUT	Com_CbkRxTOut callback which is called immediately after a message reception error has been detected by the deadline monitoring mechanism. This type of callback represents a ComTimeoutNotification. Tags: atp.Status=draft	
	COM_TX_ACK	Com_CbkTxAck callback which is called immediately after successful transmission of the I-PDU containing the message. This type of callback represents a ComNotification. Tags: atp.Status=draft	
	COM_TX_ERR	Com_CbkTxErr callback which is called in case the transmission is not possible because the corresponding I-PDU group is stopped. This type of callback represents a ComErrorNotification. Tags: atp.Status=draft	
	COM_TX_TOUT	Com_CbkTxTOut callback which is called immediately after a message transmission error has been detected by the deadline monitoring mechanism. This type of callback represents a ComTimeoutNotification. Tags: atp.Status=draft	
Post-Build Variant Multiplicity	false		
Post-Build Variant Value	false		
Multiplicity Configuration Class	Pre-compile time	X	VARIANT-PRE-COMPILE
	Link time	X	VARIANT-POST-BUILD





	Post-build time	–	
Value Configuration Class	Pre-compile time	X	VARIANT-PRE-COMPILE
	Link time	X	VARIANT-POST-BUILD
	Post-build time	–	
Scope / Dependency	scope: ECU		

No Included Containers

10.2.7.4 LdCom Proxy

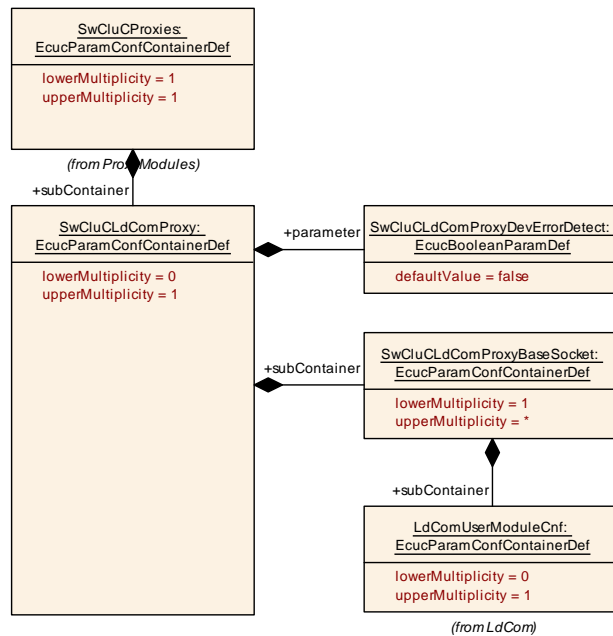

Figure 10.34: LdCom Proxy Parameter

SWS Item	[ECUC_SwCluC_00125]		
Container Name	SwCluCLdComProxy		
Parent Container	SwCluCProxies		
Description	LdCom Proxy specific parameters. Tags: atp.Status=draft		
Multiplicity Configuration Class	Pre-compile time	X	All Variants
	Link time	–	
	Post-build time	–	
Configuration Parameters			

SWS Item	[ECUC_SwCluC_00126]		
Parameter Name	SwCluCLdComProxyDevErrorDetect		
Parent Container	SwCluCLdComProxy		





Description	Switches the development error detection and notification on or off. <ul style="list-style-type: none"> • true: detection and notification is enabled. • false: detection and notification is disabled. Tags: atp.Status=draft		
Multiplicity	1		
Type	EcucBooleanParamDef		
Default value	false		
Post-Build Variant Value	false		
Value Configuration Class	Pre-compile time	X	All Variants
	Link time	–	
	Post-build time	–	
Scope / Dependency	scope: local		

Included Containers		
Container Name	Multiplicity	Scope / Dependency
SwCluCLdComProxyBaseSocket	1..*	<p>This container configures how many EcucPartitions specific API links are required for the LdCom Proxy and to which cluster resource the API set belongs.</p> <p>In the LdCom Low Proxy all offered API sets (incl. callbacks) needs to be configured. In the LdCom High Proxy only the ones are configured which are offered inside this Application Software Cluster.</p> <p>The reference SwCluCProxyEcucPartitionRef denotes the Ecuc Partition on which the API set is provided.</p> <p>The LdComUserModuleCnf is only applicable in the Host Software Cluster and shall not be configured in the scope of a Application Software Cluster. One LdComUserModuleCnf instance can either server for LdComIPdus on multiple Ecuc Partitons or exactly one EcucPartiton. How many LdComUser instances an Rte in an related Application Software Cluster requires is vendor specific.</p> <p>Tags: atp.Status=draft</p>

10.2.7.4.1 LdCom Base Socket

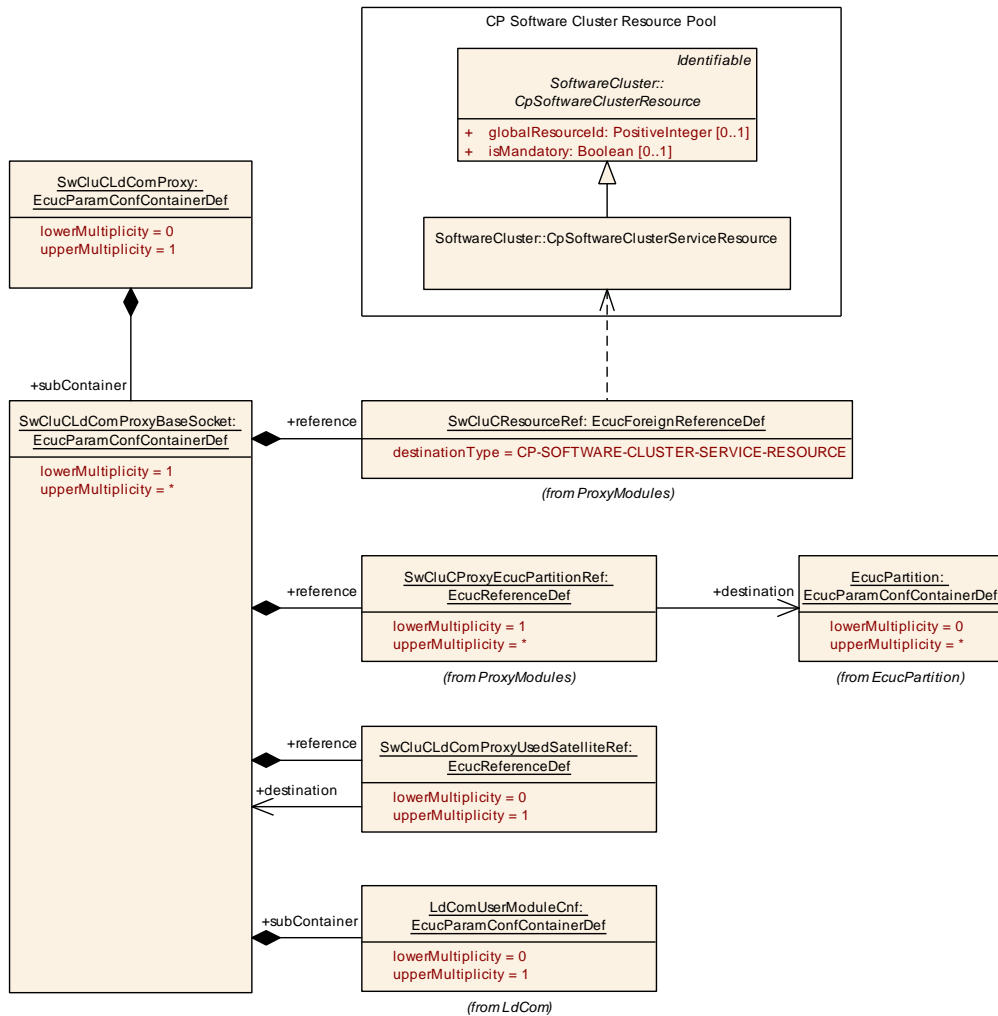

Figure 10.35: LdCom Proxy Base Socket

SWS Item	[ECUC_SwCluC_00129]
Container Name	SwCluCLdComProxyBaseSocket
Parent Container	SwCluCLdComProxy





Description	<p>This container configures how many EcucPartitions specific API links are required for the LdCom Proxy and to which cluster resource the API set belongs.</p> <p>In the LdCom Low Proxy all offered API sets (incl. callbacks) needs to be configured. In the LdCom High Proxy only the ones are configured which are offered inside this Application Software Cluster.</p> <p>The reference SwCluCProxyEcucPartitionRef denotes the EcucPartition on which the API set is provided.</p> <p>The LdComUserModuleCnf is only applicable in the Host Software Cluster and shall not be configured in the scope of a Application Software Cluster. One LdComUserModuleCnf instance can either server for LdComIPdus on multiple EcucPartitons or exactly one EcucPartiton. How many LdComUser instances an Rte in an related Application Software Cluster requires is vendor specific.</p> <p>Tags: atp.Status=draft</p>		
Multiplicity Configuration Class	Pre-compile time	X	All Variants
	Link time	–	
	Post-build time	–	
Configuration Parameters			

SWS Item	[ECUC_SwCluC_00130]		
Parameter Name	SwCluCLdComProxyUsedSatelliteRef		
Parent Container	SwCluCLdComProxyBaseSocket		
Description	<p>Reference to the SwCluCLdComBaseSocket which has access to a satellite of the Ld Com. The owning SwCluCLdComBaseSocket uses the LdCom satellite of the referenced SwCluCLdComBaseSocket.</p> <p>Tags: atp.Status=draft</p>		
Multiplicity	0..1		
Type	Reference to SwCluCLdComProxyBaseSocket		
Multiplicity Configuration Class	Pre-compile time	X	All Variants
	Link time	–	
	Post-build time	–	
Value Configuration Class	Pre-compile time	X	All Variants
	Link time	–	
	Post-build time	–	
Scope / Dependency	scope: ECU		

SWS Item	[ECUC_SwCluC_00147]		
Parameter Name	SwCluCProxyEcucPartitionRef		
Parent Container	SwCluCLdComProxyBaseSocket		
Description	<p>Reference to the EcucPartition.</p> <p>Tags: atp.Status=draft</p>		
Multiplicity	1..*		
Type	Reference to EcucPartition		
Multiplicity Configuration Class	Pre-compile time	X	All Variants
	Link time	–	
	Post-build time	–	
Value Configuration Class	Pre-compile time	X	All Variants
	Link time	–	
	Post-build time	–	
Scope / Dependency	scope: ECU		

SWS Item	[ECUC_SwCluC_00152]
Parameter Name	SwCluCResourceRef
Parent Container	SwCluCLdComProxyBaseSocket
Description	Reference to the CpSoftwareClusterServiceResource. Tags: atp.Status=draft
Multiplicity	1
Type	Foreign reference to CP-SOFTWARE-CLUSTER-SERVICE-RESOURCE
Scope / Dependency	scope: ECU

Included Containers		
Container Name	Multiplicity	Scope / Dependency
LdComUserModuleCnf	0..1	Contains the configuration parameters of the LdCom user module. Tags: atp.Status=draft

[SWS_SwCluC_CONSTR_02553]{DRAFT} [SwCluCLdComProxyBaseSocket](#) relates only to a [CpSoftwareClusterServiceResource](#) of category [SWCLUSTER_RES_LDCOM_BASE_SOCKET](#) [The [SwCluCLdComProxyBaseSocket.SwCluCResourceRef](#) shall only reference a [CpSoftwareClusterServiceResource](#) of category [SWCLUSTER_RES_LDCOM_BASE_SOCKET](#).]()

10.2.7.4.2 LdCom User module configuration

SWS Item	[ECUC_LdCom_00030]		
Container Name	LdComUserModuleCnf		
Parent Container	RteLdComUser, SwCluCLdComProxyBaseSocket		
Destination Uri Definition	LdComUser		
Description	Contains the configuration parameters of the LdCom user module. Tags: atp.Status=draft		
Post-Build Variant Multiplicity	false		
Multiplicity Configuration Class	Pre-compile time	X	All Variants
	Link time	–	
	Post-build time	–	
Configuration Parameters			

SWS Item	[ECUC_LdCom_00027]		
Parameter Name	LdComUserHeaderInclude		
Parent Container	LdComUserModuleCnf		
Description	Defines the header file where the LdCom user provides the function declarations for configured callbacks. Tags: atp.Status=draft		
Multiplicity	0..1		
Type	EcucStringParamDef		
Default value	–		





Regular Expression	-		
Post-Build Variant Value	false		
Multiplicity Configuration Class	Pre-compile time	X	All Variants
	Link time	-	
	Post-build time	-	
Value Configuration Class	Pre-compile time	X	All Variants
	Link time	-	
	Post-build time	-	
Scope / Dependency	scope: local		

Included Containers		
Container Name	Multiplicity	Scope / Dependency
LdComUserCallback	0..*	This container defines a LdCom callback function for a LdCom IPdu. Tags: atp.Status=draft
LdComUserIPdu	0..*	Contains the configuration parameters for the LdCom's signal (LdComIPdu) inside a LdCom user module. Tags: atp.Status=draft

10.2.7.4.3 LdCom User IPdus

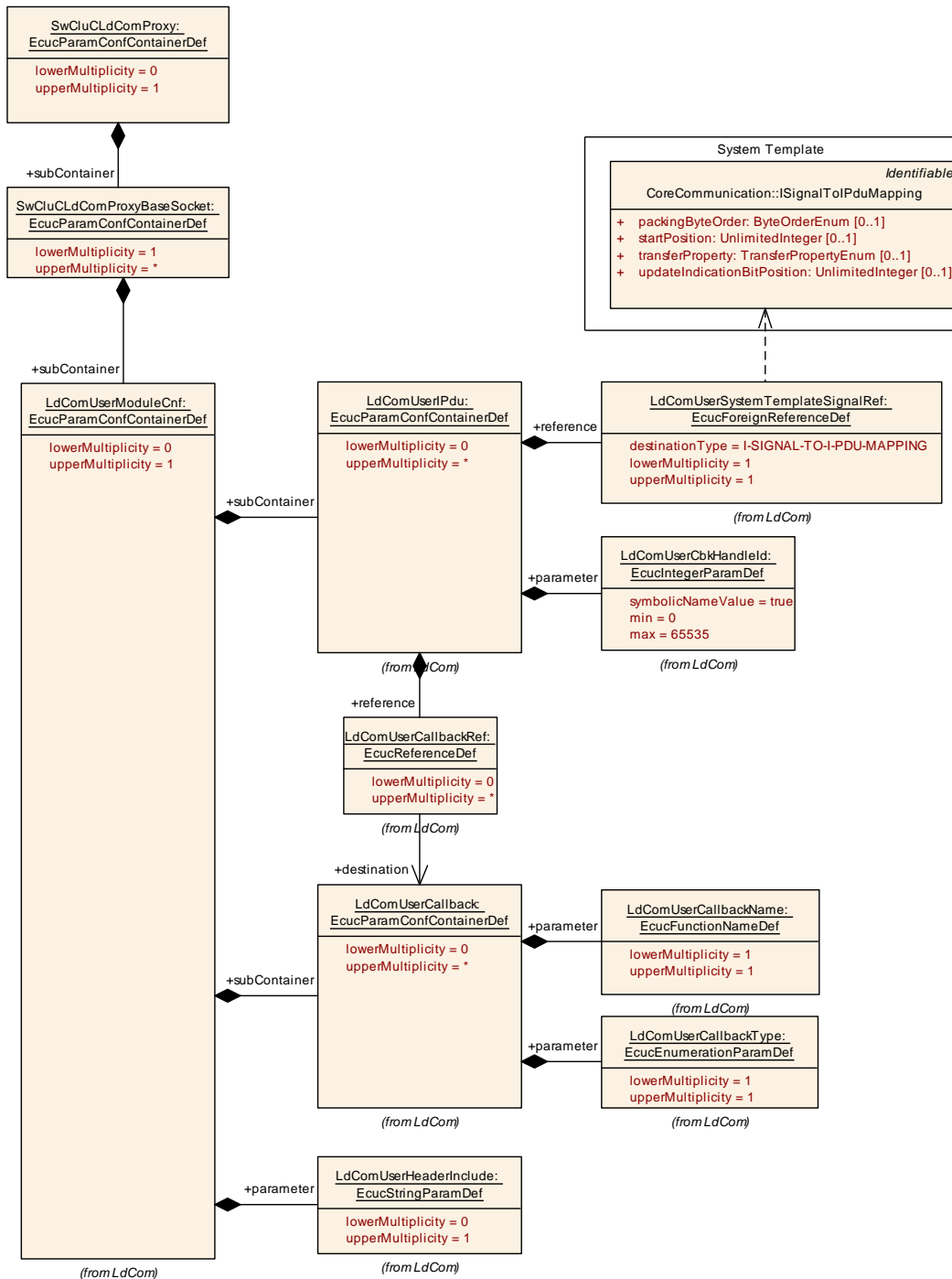

Figure 10.36: LdCom User module configuration

SWS Item	[ECUC_LdCom_00028]
Container Name	LdComUserIPdu
Parent Container	LdComUserModuleCnf





Description	Contains the configuration parameters for the LdCom's signal (LdComIPdu) inside a Ld Com user module. Tags: atp.Status=draft		
Post-Build Variant Multiplicity	true		
Multiplicity Configuration Class	Pre-compile time	X	VARIANT-PRE-COMPILE
	Link time	–	
	Post-build time	X	VARIANT-POST-BUILD
Configuration Parameters			

SWS Item	[ECUC_LdCom_00026]		
Parameter Name	LdComUserCbkJHandleId		
Parent Container	LdComUserIPdu		
Description	<p>The numerical value used as the LdCom user callback handle Id.</p> <p>This is the ID used by LdCom to invoke callbacks of a LdCom user (Rte, ScCluC Ld Com Low Proxy or CDDs) using LdComUserCbkJHandleId parameter respectively.</p> <p>A corresponding symbolic name reference is created, which may be used for the invocations of the user.</p> <p>Tags: atp.Status=draft</p>		
Multiplicity	1		
Type	EcucIntegerParamDef (Symbolic Name generated for this parameter)		
Range	0 .. 65535		
Default value	–		
Post-Build Variant Value	false		
Value Configuration Class	Pre-compile time	X	All Variants
	Link time	–	
	Post-build time	–	
Scope / Dependency	scope: ECU		

SWS Item	[ECUC_LdCom_00024]		
Parameter Name	LdComUserCallbackRef		
Parent Container	LdComUserIPdu		
Description	<p>Reference(s) to all callback(s) of this LdComIPdu.</p> <p>Tags: atp.Status=draft</p>		
Multiplicity	0..*		
Type	Reference to LdComUserCallback		
Post-Build Variant Multiplicity	true		
Post-Build Variant Value	true		
Multiplicity Configuration Class	Pre-compile time	X	VARIANT-PRE-COMPILE
	Link time	–	
	Post-build time	X	VARIANT-POST-BUILD
Value Configuration Class	Pre-compile time	X	VARIANT-PRE-COMPILE
	Link time	X	VARIANT-POST-BUILD
	Post-build time	–	
Scope / Dependency	scope: ECU		

SWS Item	[ECUC_LdCom_00033]		
Parameter Name	LdComUserSystemTemplateSignalRef		
Parent Container	LdComUserIPdu		
Description	Reference to the ISignalToIPduMapping that contains a reference to the ISignal (System Template). Tags: atp.Status=draft		
Multiplicity	1		
Type	Foreign reference to I-SIGNAL-TO-I-PDU-MAPPING		
Post-Build Variant Multiplicity	true		
Post-Build Variant Value	true		
Multiplicity Configuration Class	Pre-compile time	X	VARIANT-PRE-COMPILE
	Link time	–	
	Post-build time	X	VARIANT-POST-BUILD
Value Configuration Class	Pre-compile time	X	VARIANT-PRE-COMPILE
	Link time	–	
	Post-build time	X	VARIANT-POST-BUILD
Scope / Dependency	scope: ECU		

No Included Containers

10.2.7.4.4 LdCom User callbacks

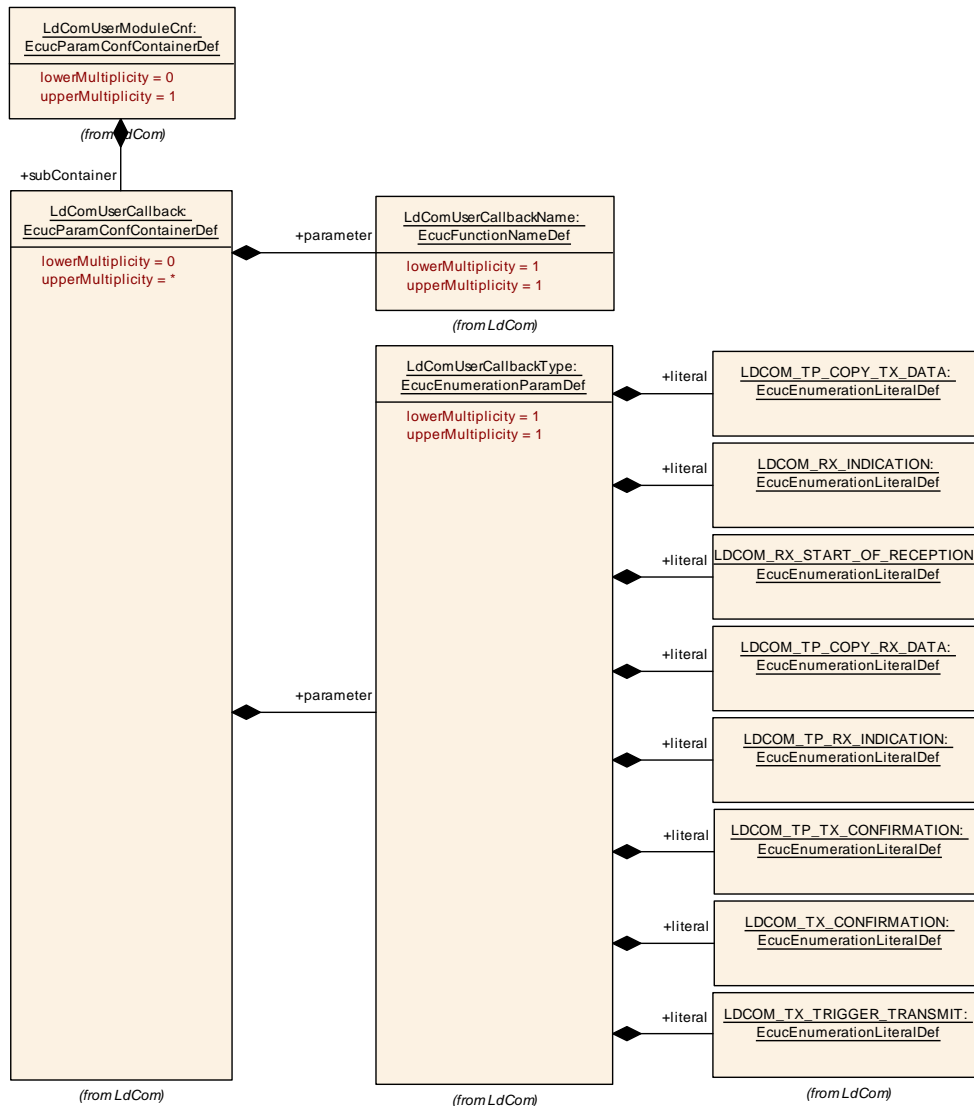

Figure 10.37: LdCom User callbacks

SWS Item	[ECUC_LdCom_00022]		
Container Name	LdComUserCallback		
Parent Container	LdComUserModuleCnf		
Description	This container defines a LdCom callback function for a LdComIPdu. Tags: atp.Status=draft		
Post-Build Variant Multiplicity	true		
Multiplicity Configuration Class	Pre-compile time	X	VARIANT-PRE-COMPILE
	Link time	X	VARIANT-POST-BUILD
	Post-build time	-	
Configuration Parameters			

SWS Item	[ECUC_LdCom_00023]		
Parameter Name	LdComUserCallbackName		
Parent Container	LdComUserCallback		
Description	The name of the callback function to be called. Tags: atp.Status=draft		
Multiplicity	1		
Type	EcucFunctionNameDef		
Default value	-		
Regular Expression	-		
Post-Build Variant Multiplicity	false		
Post-Build Variant Value	false		
Multiplicity Configuration Class	Pre-compile time	X	VARIANT-PRE-COMPILE
	Link time	X	VARIANT-POST-BUILD
	Post-build time	-	
Value Configuration Class	Pre-compile time	X	VARIANT-PRE-COMPILE
	Link time	X	VARIANT-POST-BUILD
	Post-build time	-	
Scope / Dependency	scope: ECU		

SWS Item	[ECUC_LdCom_00025]		
Parameter Name	LdComUserCallbackType		
Parent Container	LdComUserCallback		
Description	The type of the LdCom callback Tags: atp.Status=draft		
Multiplicity	1		
Type	EcucEnumerationParamDef		
Range	LDCOM_RX_INDICATION	LdComCbkJRxIndication callback indicates a received PDU from a lower layer communication interface module. Tags: atp.Status=draft	
	LDCOM_RX_START_OF_RECEPTION	LdComCbkJStartOfReception callback called at the start of receiving an N-SDU. Tags: atp.Status=draft	
	LDCOM_TP_COPY_RX_DATA	LdComCbkJCopyRxData callback to provide the received data of an I-PDU segment (N-PDU) to the upper layer. Tags: atp.Status=draft	
	LDCOM_TP_COPY_TX_DATA	LdComCbkJCopyTxData callback to acquire the transmit data of an I-PDU segment. Tags: atp.Status=draft	
	LDCOM_TP_RX_INDICATION	LdComCbkJTpRxIndication callback called after an I-PDU has been received via the TP API Tags: atp.Status=draft	
	LDCOM_TP_TX_CONFIRMATION	LdComCbkJTpTxConfirmation callback called after a Signal has been transmitted via the TP-API on its network. Tags: atp.Status=draft	





	LDCOM_TX_CONFIRMATION	LdComCbTxConfirmation callback which is called when the lower layer communication interface module confirms the transmission of a PDU, or the failure to transmit a PDU. Tags: atp.Status=draft	
	LDCOM_TX_TRIGGER_TRANSMIT	LdComCbTxConfirmation callback which is called when the lower layer communication interface module confirms the transmission of a PDU, or the failure to transmit a PDU. Tags: atp.Status=draft	
Post-Build Variant Multiplicity	false		
Post-Build Variant Value	false		
Multiplicity Configuration Class	Pre-compile time	X	VARIANT-PRE-COMPILE
	Link time	X	VARIANT-POST-BUILD
	Post-build time	–	
Value Configuration Class	Pre-compile time	X	VARIANT-PRE-COMPILE
	Link time	X	VARIANT-POST-BUILD
	Post-build time	–	
Scope / Dependency	scope: ECU		

No Included Containers

10.2.7.5 Dcm Proxy

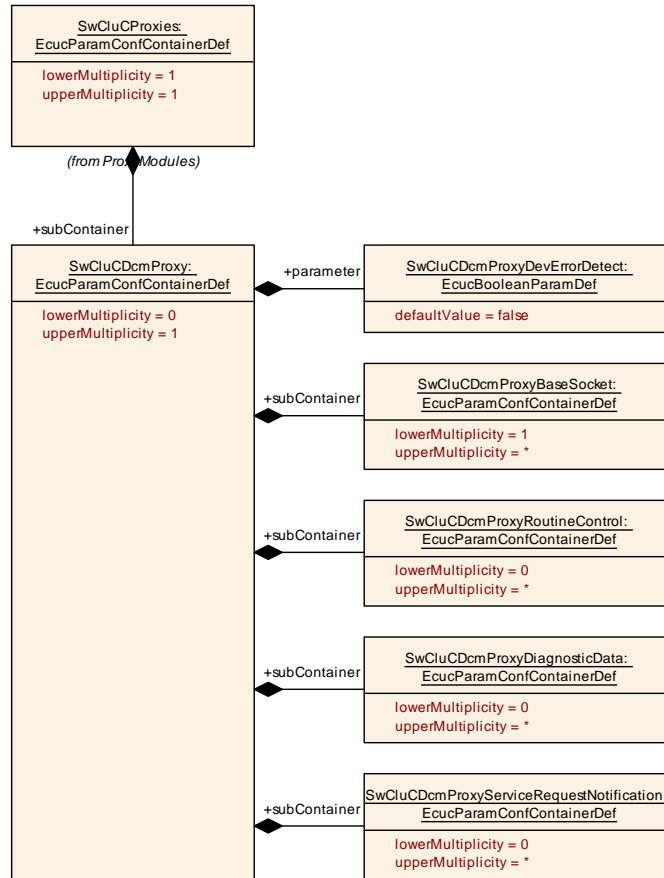

Figure 10.38: Dcm Proxy Parameter

SWS Item	[ECUC_SwCluC_00118]		
Container Name	SwCluCDcmProxy		
Parent Container	SwCluCProxies		
Description	Dcm Proxy specific parameters. Tags: atp.Status=draft		
Multiplicity Configuration Class	Pre-compile time	X	All Variants
	Link time	–	
	Post-build time	–	
Configuration Parameters			

SWS Item	[ECUC_SwCluC_00137]		
Parameter Name	SwCluCDcmProxyDevErrorDetect		
Parent Container	SwCluCDcmProxy		
Description	Switches the development error detection and notification on or off. <ul style="list-style-type: none"> • true: detection and notification is enabled. • false: detection and notification is disabled. Tags: atp.Status=draft		





Multiplicity	1		
Type	EcucBooleanParamDef		
Default value	false		
Post-Build Variant Value	false		
Value Configuration Class	Pre-compile time	X	All Variants
	Link time	–	
	Post-build time	–	
Scope / Dependency	scope: local		

Included Containers		
Container Name	Multiplicity	Scope / Dependency
SwCluCDcmProxyBaseSocket	1..*	<p>This container configures how many EcucPartitions specific API links are required for the Dcm Proxy and to which cluster resource the API set belongs.</p> <p>In the Dcm Low Proxy all offered API sets needs to be configured. In the Dcm High Proxy only the ones are configured which are offered inside this Application Software Cluster.</p> <p>The reference SwCluCProxyEcucPartitionRef denotes the Ecuc Partition on which the API set is provided.</p> <p>Tags: atp.Status=draft</p>
SwCluCDcmProxyDiagnosticData	0..*	<p>Configures a Diagnostic Data proxy for a DID or PID or IOControl.</p> <p>Tags: atp.Status=draft</p>
SwCluCDcmProxyRoutineControl	0..*	<p>Configures a Routine Control proxy.</p> <p>Tags: atp.Status=draft</p>
SwCluCDcmProxyServiceRequest Notification	0..*	<p>Configures a Service Request Notification proxy.</p> <p>Tags: atp.Status=draft</p>

10.2.7.5.1 Dcm Base Socket

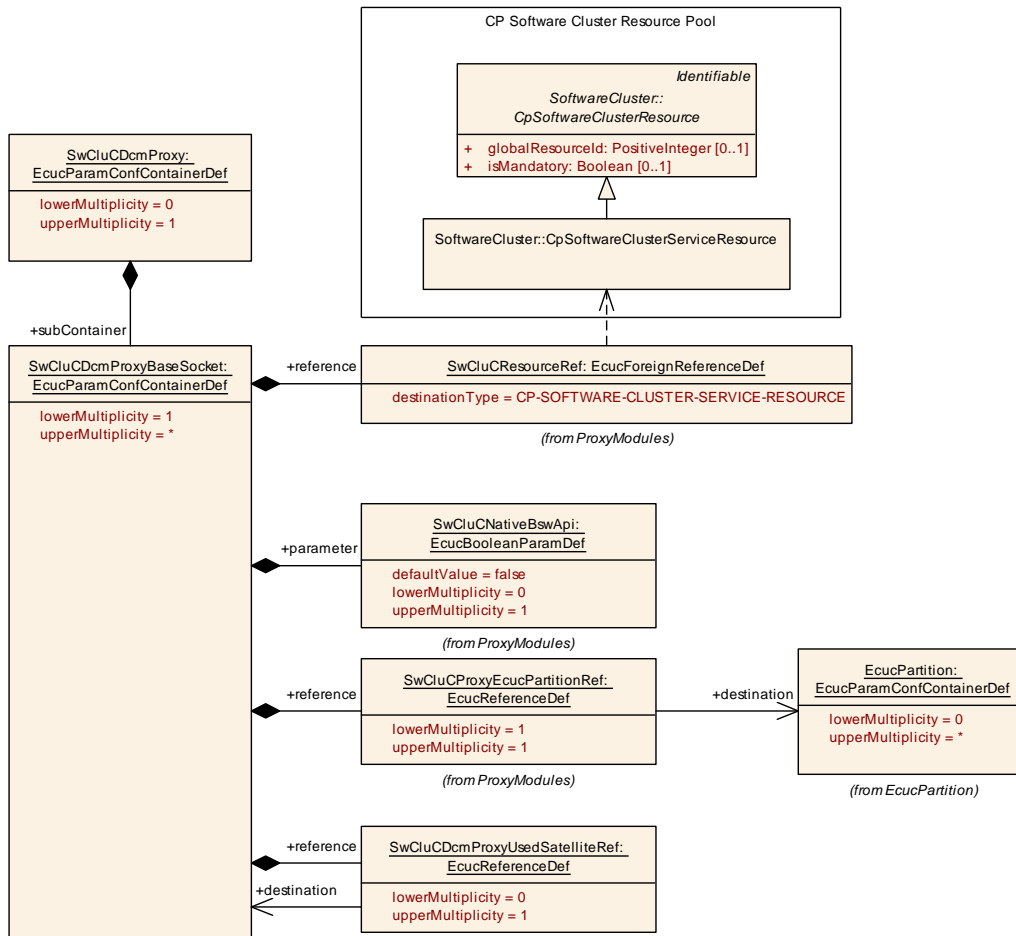

Figure 10.39: Dcm Proxy Base Socket

SWS Item	[ECUC_SwCluC_00120]		
Container Name	SwCluCdcmProxyBaseSocket		
Parent Container	SwCluCDcmProxy		
Description	<p>This container configures how many EcucPartitions specific API links are required for the Dcm Proxy and to which cluster resource the API set belongs.</p> <p>In the Dcm Low Proxy all offered API sets needs to be configured. In the Dcm High Proxy only the ones are configured which are offered inside this Application Software Cluster.</p> <p>The reference SwCluCProxyEcucPartitionRef denotes the EcucPartition on which the API set is provided.</p> <p>Tags: atp.Status=draft</p>		
Multiplicity Configuration Class	Pre-compile time	X	All Variants
	Link time	–	
	Post-build time	–	
Configuration Parameters			

SWS Item	[ECUC_SwCluC_00058]		
Parameter Name	SwCluCNativeBswApi		
Parent Container	SwCluCDcmProxyBaseSocket		
Description	<p>Defines if the native C-API without pre or suffixes is offered in the Application Software Cluster on this EcucPartition.</p> <p>This Parameter is only relevant for the NvM High Proxy.</p> <p>Tags: atp.Status=draft</p>		
Multiplicity	0..1		
Type	EcucBooleanParamDef		
Default value	false		
Post-Build Variant Value	false		
Multiplicity Configuration Class	Pre-compile time	X	All Variants
	Link time	–	
	Post-build time	–	
Value Configuration Class	Pre-compile time	X	All Variants
	Link time	–	
	Post-build time	–	
Scope / Dependency	scope: ECU		

SWS Item	[ECUC_SwCluC_00121]		
Parameter Name	SwCluCDcmProxyUsedSatelliteRef		
Parent Container	SwCluCDcmProxyBaseSocket		
Description	<p>Reference to the SwCluCDemBaseSocket which has access to a satellite of the Dcm. The owning SwCluCDemBaseSocket uses the Dcm satellite of the referenced SwCluCDemBaseSocket.</p> <p>Tags: atp.Status=draft</p>		
Multiplicity	0..1		
Type	Reference to SwCluCDcmProxyBaseSocket		
Multiplicity Configuration Class	Pre-compile time	X	All Variants
	Link time	–	
	Post-build time	–	
Value Configuration Class	Pre-compile time	X	All Variants
	Link time	–	
	Post-build time	–	
Scope / Dependency	scope: ECU		

SWS Item	[ECUC_SwCluC_00059]		
Parameter Name	SwCluCProxyEcucPartitionRef		
Parent Container	SwCluCDcmProxyBaseSocket		
Description	<p>Reference to the EcucPartition.</p> <p>Tags: atp.Status=draft</p>		
Multiplicity	1		
Type	Reference to EcucPartition		
Multiplicity Configuration Class	Pre-compile time	X	All Variants
	Link time	–	
	Post-build time	–	
Value Configuration Class	Pre-compile time	X	All Variants





	Link time	-	
	Post-build time	-	
Scope / Dependency	scope: ECU		

SWS Item	[ECUC_SwCluC_00149]
Parameter Name	SwCluCResourceRef
Parent Container	SwCluCDCmProxyBaseSocket
Description	Reference to the CpSoftwareClusterServiceResource. Tags: atp.Status=draft
Multiplicity	1
Type	Foreign reference to CP-SOFTWARE-CLUSTER-SERVICE-RESOURCE
Scope / Dependency	scope: ECU

No Included Containers

[SWS_SwCluC_CONSTR_02752]{DRAFT} [SwCluCDCmProxyBaseSocket](#) relates only to a [CpSoftwareClusterServiceResource](#) of category [SWCLUSTER_RES_DCM_BASE_SOCKET](#) [The [SwCluCDCmProxyBaseSocket.SwCluCResourceRef](#) shall only reference a [CpSoftwareClusterServiceResource](#) of category [SWCLUSTER_RES_DCM_BASE_SOCKET](#).]()

10.2.7.5.2 Dcm Proxy Diagnostic Data

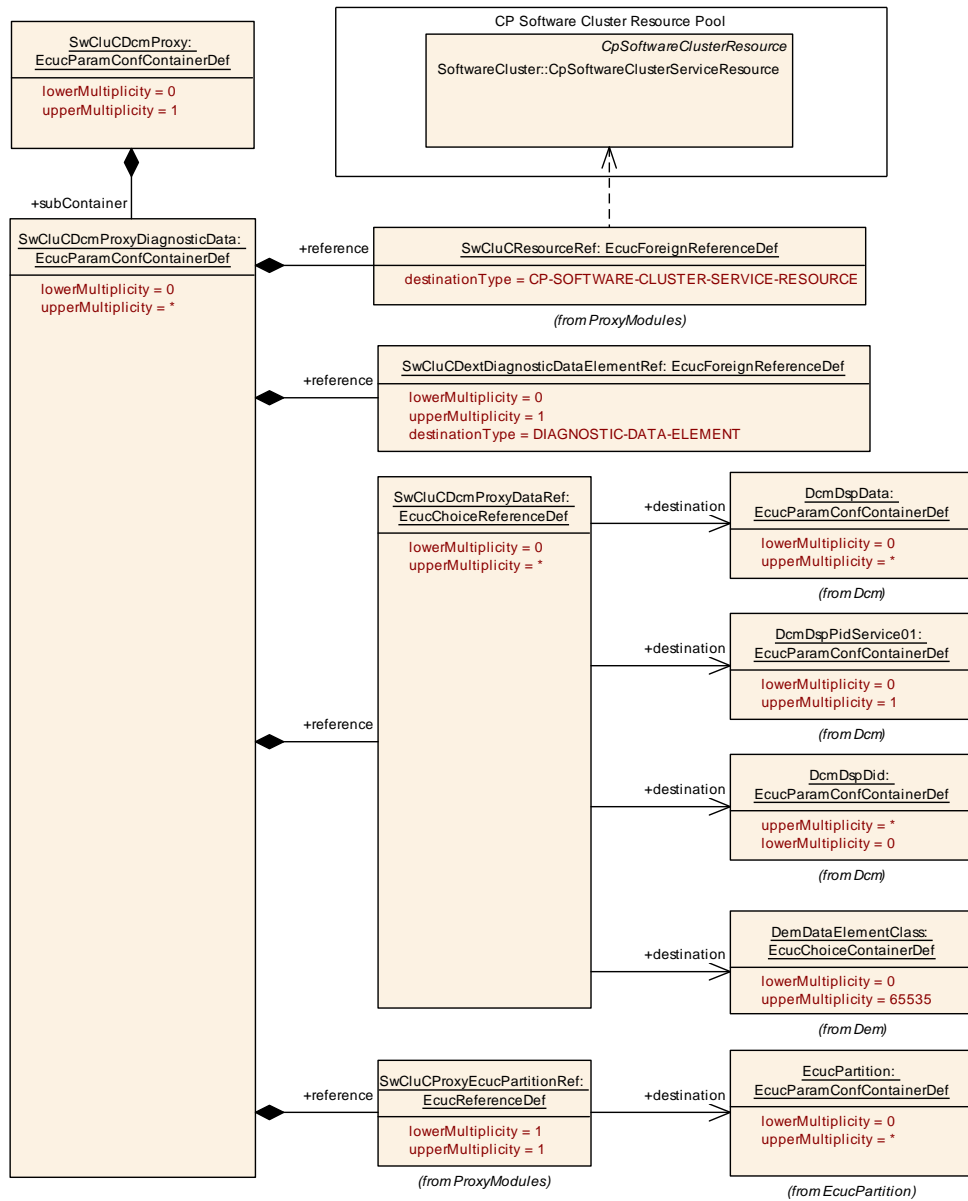

Figure 10.40: Dcm Proxy Diagnostic Data

SWS Item	[ECUC_SwCluC_00122]		
Container Name	SwCluCDcmProxyDiagnosticData		
Parent Container	SwCluCDcmProxy		
Description	Configures a Diagnostic Data proxy for a DID or PID or IOControl. Tags: atp.Status=draft		
Multiplicity Configuration Class	Pre-compile time	X	All Variants
	Link time	–	
	Post-build time	–	
Configuration Parameters			

SWS Item	[ECUC_SwCluC_00123]
Parameter Name	SwCluCDCmProxyDataRef
Parent Container	SwCluCDCmProxyDiagnosticData
Description	<p>Reference to the diagnostic data of Dcm which can either be a DcmDspData, or a DcmDspPidService01, or a DcmDspDid.</p> <p>The DcmDspDid reference is only applicable in the Application Software Cluster if the DID has exactly one Diagnostic Data Element requiring the DID based interface.</p> <p>The reference is mandatory in the Application Software Cluster and can be used in the Host Software Cluster to identify the related diagnostic data in the Dcm configuration.</p> <p>Tags: atp.Status=draft</p>
Multiplicity	0..*
Type	Choice reference to [DcmDspData , DcmDspDid , DcmDspPidService01 , DemDataElementClass]
Scope / Dependency	scope: ECU

SWS Item	[ECUC_SwCluC_00138]
Parameter Name	SwCluCDextDiagnosticDataElementRef
Parent Container	SwCluCDCmProxyDiagnosticData
Description	<p>Reference to the DiagnosticDataElement in DEXT for back-tracing in case of DEXT based configuration approaches</p> <p>Tags: atp.Status=draft</p>
Multiplicity	0..1
Type	Foreign reference to DIAGNOSTIC-DATA-ELEMENT
Scope / Dependency	scope: ECU

SWS Item	[ECUC_SwCluC_00059]		
Parameter Name	SwCluCProxyEcucPartitionRef		
Parent Container	SwCluCDCmProxyDiagnosticData		
Description	<p>Reference to the EcucPartition.</p> <p>Tags: atp.Status=draft</p>		
Multiplicity	1		
Type	Reference to EcucPartition		
Multiplicity Configuration Class	Pre-compile time	X	All Variants
	Link time	–	
	Post-build time	–	
Value Configuration Class	Pre-compile time	X	All Variants
	Link time	–	
	Post-build time	–	
Scope / Dependency	scope: ECU		

SWS Item	[ECUC_SwCluC_00139]
Parameter Name	SwCluCResourceRef
Parent Container	SwCluCDCmProxyDiagnosticData
Description	<p>Reference to the CpSoftwareClusterServiceResource.</p> <p>Tags: atp.Status=draft</p>
Multiplicity	1
Type	Foreign reference to CP-SOFTWARE-CLUSTER-SERVICE-RESOURCE
Scope / Dependency	scope: ECU

No Included Containers

[SWS_SwCluC_CONSTR_02427]{DRAFT} **SwCluCDcmProxyDiagnosticData** relates only to a **CpSoftwareClusterServiceResource** of category **SWCLUSTER_RES_DCM_DIAGNOSTIC_DATA** [The **SwCluCDcmProxyDiagnosticData.SwCluCResourceRef** shall only reference a **CpSoftwareClusterServiceResource** of category **SWCLUSTER_RES_DCM_DIAGNOSTIC_DATA**.]()

10.2.7.5.3 Dcm Proxy Routine Control

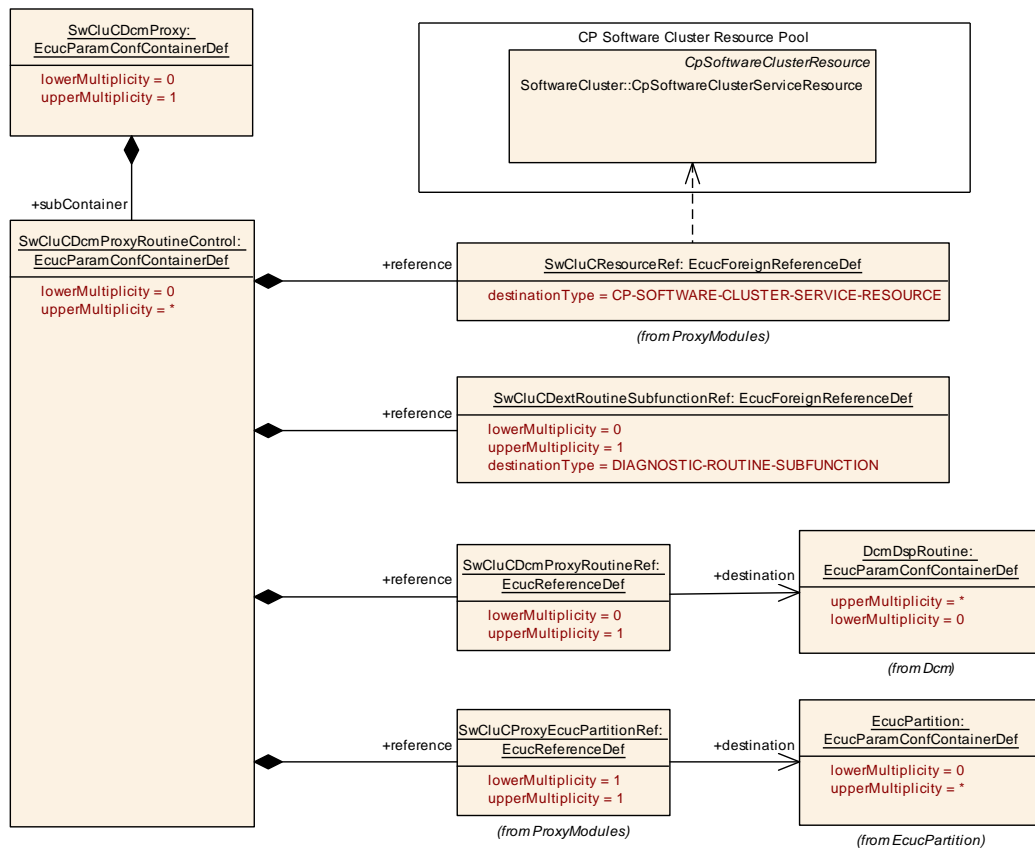

Figure 10.41: Dcm Proxy Routine Control

SWS Item	[ECUC_SwCluC_00133]		
Container Name	SwCluCDcmProxyRoutineControl		
Parent Container	SwCluCDcmProxy		
Description	Configures a Routine Control proxy. Tags: atp.Status=draft		
Multiplicity Configuration Class	Pre-compile time	X	All Variants
	Link time	-	
	Post-build time	-	





Configuration Parameters	
--------------------------	--

SWS Item	[ECUC_SwCluC_00136]
Parameter Name	SwCluCDcmProxyRoutineRef
Parent Container	SwCluCDcmProxyRoutineControl
Description	Reference to the routine configuration of Dcm. The reference is mandatory in the Application Software Cluster and can be used in the Host Software Cluster to identify the related routine control in the Dcm configuration. Tags: atp.Status=draft
Multiplicity	0..1
Type	Reference to DcmDspRoutine
Scope / Dependency	scope: ECU

SWS Item	[ECUC_SwCluC_00135]
Parameter Name	SwCluCDextRoutineSubfunctionRef
Parent Container	SwCluCDcmProxyRoutineControl
Description	Reference to the Routine Subfunction in DEXT for back-tracing in case of DEXT based configuration approaches Tags: atp.Status=draft
Multiplicity	0..1
Type	Foreign reference to DIAGNOSTIC-ROUTINE-SUBFUNCTION
Scope / Dependency	scope: ECU

SWS Item	[ECUC_SwCluC_00059]		
Parameter Name	SwCluCProxyEcucPartitionRef		
Parent Container	SwCluCDcmProxyRoutineControl		
Description	Reference to the EcucPartition. Tags: atp.Status=draft		
Multiplicity	1		
Type	Reference to EcucPartition		
Multiplicity Configuration Class	Pre-compile time	X	All Variants
	Link time	–	
	Post-build time	–	
Value Configuration Class	Pre-compile time	X	All Variants
	Link time	–	
	Post-build time	–	
Scope / Dependency	scope: ECU		

SWS Item	[ECUC_SwCluC_00134]
Parameter Name	SwCluCResourceRef
Parent Container	SwCluCDcmProxyRoutineControl
Description	Reference to the CpSoftwareClusterServiceResource. Tags: atp.Status=draft
Multiplicity	1
Type	Foreign reference to CP-SOFTWARE-CLUSTER-SERVICE-RESOURCE
Scope / Dependency	scope: ECU

No Included Containers

[SWS_SwCluC_CONSTR_02428]{DRAFT} **SwCluCDCmProxyRoutineControl** relates only to a **CpSoftwareClusterServiceResource** of category **SWCLUSTER_RES_DCM_ROUTINE_CONTROL** [The `SwCluCDCmProxyRoutineControl.SwCluCResourceRef` shall only reference a `CpSoftwareClusterServiceResource` of category `SWCLUSTER_RES_DCM_ROUTINE_CONTROL`.]()

10.2.7.5.4 Dcm Proxy Service Request Notification

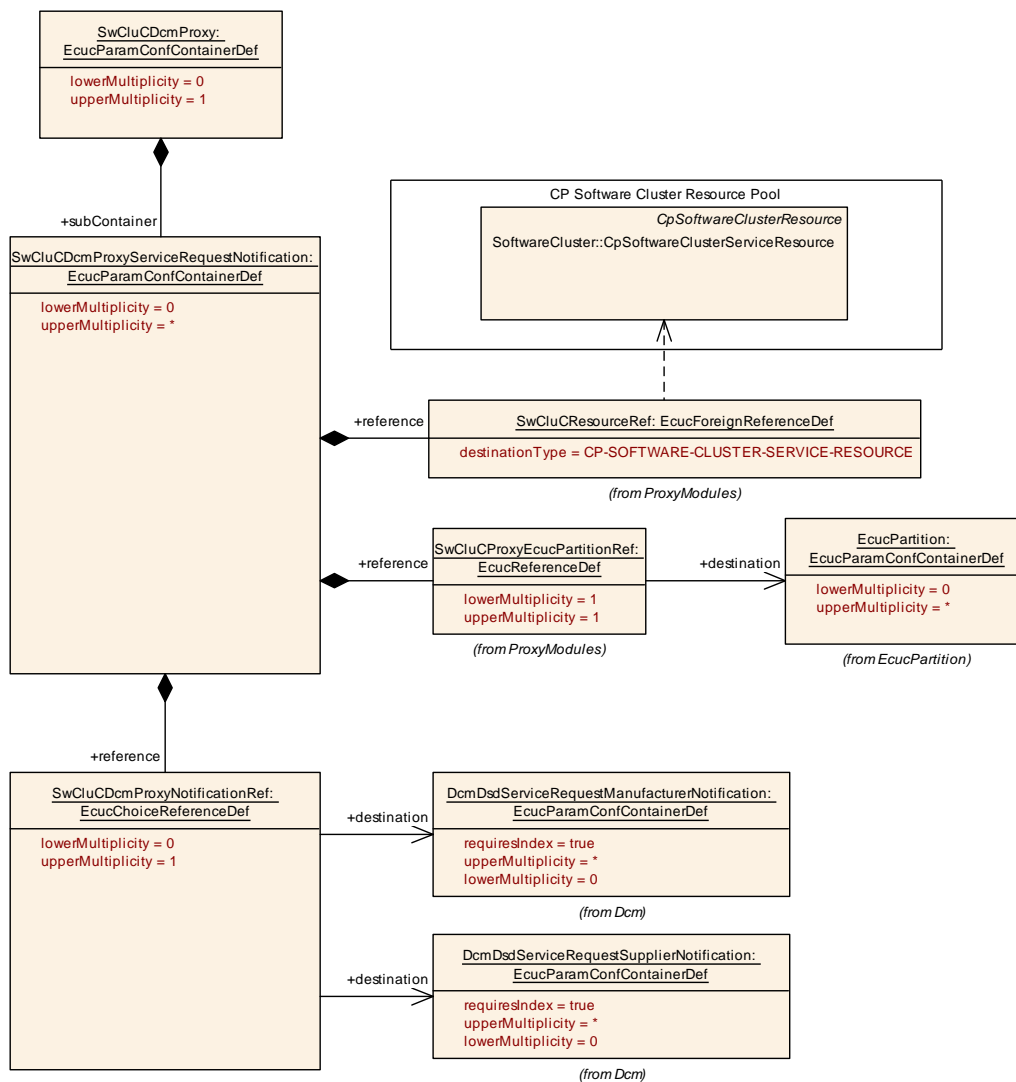

Figure 10.42: Dcm Proxy Service Request Notification

SWS Item	[ECUC_SwCluC_00145]
Container Name	SwCluCDcmProxyServiceRequestNotification
Parent Container	SwCluCDcmProxy





Description	Configures a Service Request Notification proxy. Tags: atp.Status=draft		
Multiplicity Configuration Class	Pre-compile time	X	All Variants
	Link time	–	
	Post-build time	–	
Configuration Parameters			

SWS Item	[ECUC_SwCluC_00146]		
Parameter Name	SwCluCDcmProxyNotificationRef		
Parent Container	SwCluCDcmProxyServiceRequestNotification		
Description	Reference to the Service Request Notification configuration of Dcm which can either be a DcmDsdServiceRequestSupplierNotification or DcmDsdServiceRequestManufacturerNotification The reference is mandatory in the Application Software Cluster and can be used in the Host Software Cluster to identify the related notification in the Dcm configuration. Tags: atp.Status=draft		
Multiplicity	0..1		
Type	Choice reference to [DcmDsdServiceRequestManufacturerNotification, DcmDsdServiceRequestSupplierNotification]		
Scope / Dependency	scope: ECU		

SWS Item	[ECUC_SwCluC_00059]		
Parameter Name	SwCluCProxyEcucPartitionRef		
Parent Container	SwCluCDcmProxyServiceRequestNotification		
Description	Reference to the EcucPartition. Tags: atp.Status=draft		
Multiplicity	1		
Type	Reference to EcucPartition		
Multiplicity Configuration Class	Pre-compile time	X	All Variants
	Link time	–	
	Post-build time	–	
Value Configuration Class	Pre-compile time	X	All Variants
	Link time	–	
	Post-build time	–	
Scope / Dependency	scope: ECU		

SWS Item	[ECUC_SwCluC_00143]		
Parameter Name	SwCluCResourceRef		
Parent Container	SwCluCDcmProxyServiceRequestNotification		
Description	Reference to the CpSoftwareClusterServiceResource. Tags: atp.Status=draft		
Multiplicity	1		
Type	Foreign reference to CP-SOFTWARE-CLUSTER-SERVICE-RESOURCE		
Scope / Dependency	scope: ECU		

No Included Containers

[SWS_SwCluC_CONSTR_02429]{DRAFT} [SwCluCDcmProxyServiceRequestNotification](#) relates only to a [CpSoftwareClusterServiceResource](#) of

category `SWCLUSTER_RES_DCM_SERVICE_REQUEST_NOTIFICATION` [The `SwCluCdmProxyServiceRequestNotification.SwCluCResourceRef` shall only reference a `CpSoftwareClusterServiceResource` of category `SWCLUSTER_RES_DCM_SERVICE_REQUEST_NOTIFICATION`.]()

10.2.7.6 Dem Proxy

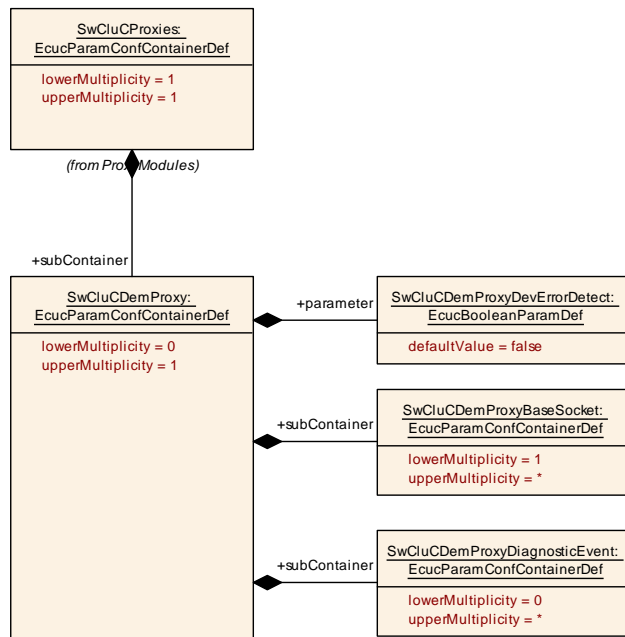

Figure 10.43: Dem Proxy Parameter

SWS Item	[ECUC_SwCluC_00112]		
Container Name	SwCluCDemProxy		
Parent Container	SwCluCPxies		
Description	DemProxy specific parameters. Tags: atp.Status=draft		
Multiplicity Configuration Class	Pre-compile time	X	All Variants
	Link time	–	
	Post-build time	–	
Configuration Parameters			

SWS Item	[ECUC_SwCluC_00113]		
Parameter Name	SwCluCDemProxyDevErrorDetect		
Parent Container	SwCluCDemProxy		





Description	Switches the development error detection and notification on or off. <ul style="list-style-type: none"> • true: detection and notification is enabled. • false: detection and notification is disabled. Tags: atp.Status=draft		
Multiplicity	1		
Type	EcucBooleanParamDef		
Default value	false		
Post-Build Variant Value	false		
Value Configuration Class	Pre-compile time	X	All Variants
	Link time	–	
	Post-build time	–	
Scope / Dependency	scope: local		

Included Containers		
Container Name	Multiplicity	Scope / Dependency
SwCluCProxyBaseSocket	1..*	<p>This container configures how many EcucPartitions specific API links are required for the Dem Proxy and to which cluster resource the API set belongs.</p> <p>In the Dem Low Proxy all offered API sets needs to be configured. In the Dem High Proxy only the ones are configured which are offered inside this Application Software Cluster.</p> <p>The reference SwCluCProxyEcucPartitionRef denotes the Ecuc Partition on which the API set is provided.</p> <p>Tags: atp.Status=draft</p>
SwCluCProxyDiagnosticEvent	0..*	<p>Configures a Diagnostic Event proxy.</p> <p>Tags: atp.Status=draft</p>

10.2.7.6.1 Dem Base Socket

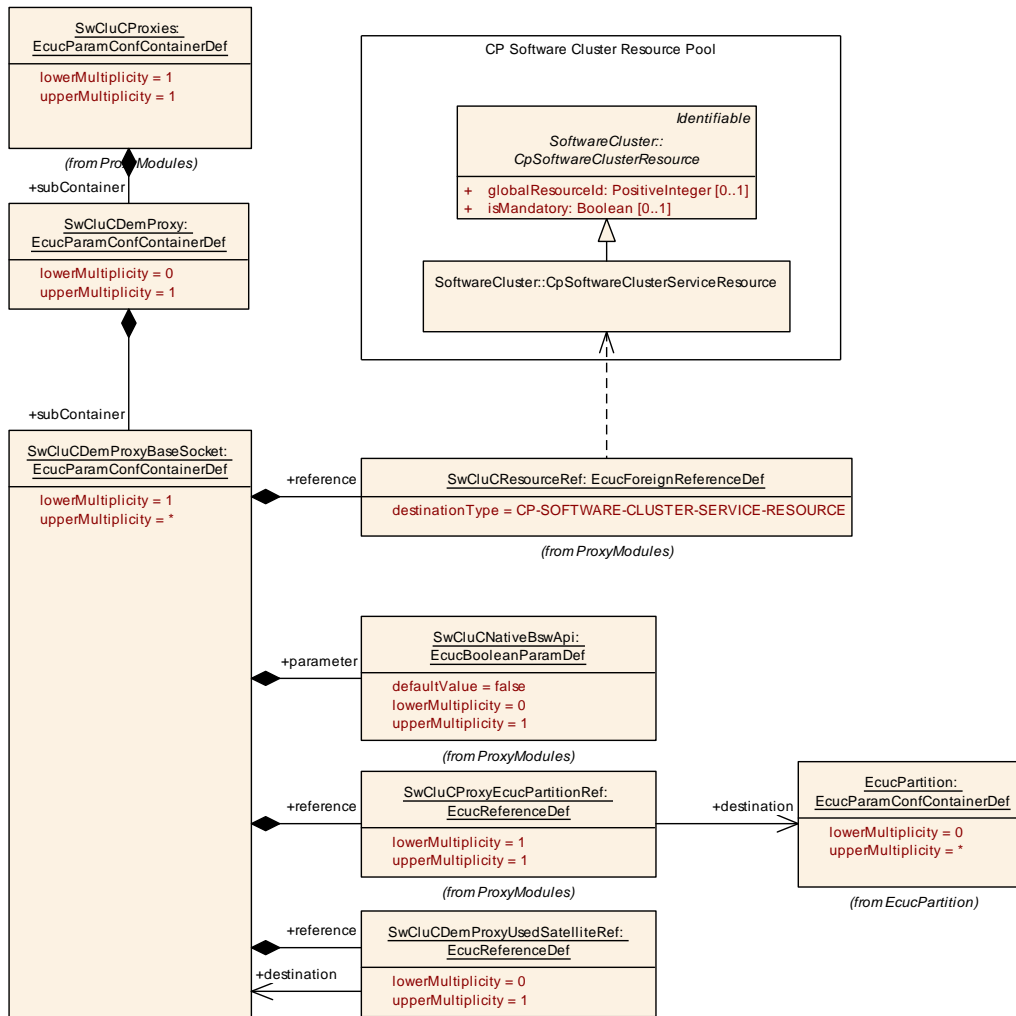

Figure 10.44: Dem Proxy Base Socket

SWS Item	[ECUC_SwCluC_00114]		
Container Name	SwCluCDemProxyBaseSocket		
Parent Container	SwCluCDemProxy		
Description	<p>This container configures how many EcucPartitions specific API links are required for the Dem Proxy and to which cluster resource the API set belongs.</p> <p>In the Dem Low Proxy all offered API sets needs to be configured. In the Dem High Proxy only the ones are configured which are offered inside this Application Software Cluster.</p> <p>The reference SwCluCProxyEcucPartitionRef denotes the EcucPartition on which the API set is provided.</p> <p>Tags: atp.Status=draft</p>		
Multiplicity Configuration Class	Pre-compile time	X	All Variants
	Link time	–	
	Post-build time	–	
Configuration Parameters			

SWS Item	[ECUC_SwCluC_00058]		
Parameter Name	SwCluCNativeBswApi		
Parent Container	SwCluCDemProxyBaseSocket		
Description	<p>Defines if the native C-API without pre or suffixes is offered in the Application Software Cluster on this EcucPartition.</p> <p>This Parameter is only relevant for the NvM High Proxy.</p> <p>Tags: atp.Status=draft</p>		
Multiplicity	0..1		
Type	EcucBooleanParamDef		
Default value	false		
Post-Build Variant Value	false		
Multiplicity Configuration Class	Pre-compile time	X	All Variants
	Link time	–	
	Post-build time	–	
Value Configuration Class	Pre-compile time	X	All Variants
	Link time	–	
	Post-build time	–	
Scope / Dependency	scope: ECU		

SWS Item	[ECUC_SwCluC_00115]		
Parameter Name	SwCluCDemProxyUsedSatelliteRef		
Parent Container	SwCluCDemProxyBaseSocket		
Description	<p>Reference to the SwCluCDemBaseSocket which has access to a satellite of the Dem. The owning SwCluCDemBaseSocket uses the Dem satellite of the referenced SwCluCDemBaseSocket.</p> <p>Tags: atp.Status=draft</p>		
Multiplicity	0..1		
Type	Reference to SwCluCDemProxyBaseSocket		
Multiplicity Configuration Class	Pre-compile time	X	All Variants
	Link time	–	
	Post-build time	–	
Value Configuration Class	Pre-compile time	X	All Variants
	Link time	–	
	Post-build time	–	
Scope / Dependency	scope: ECU		

SWS Item	[ECUC_SwCluC_00059]		
Parameter Name	SwCluCProxyEcucPartitionRef		
Parent Container	SwCluCDemProxyBaseSocket		
Description	<p>Reference to the EcucPartition.</p> <p>Tags: atp.Status=draft</p>		
Multiplicity	1		
Type	Reference to EcucPartition		
Multiplicity Configuration Class	Pre-compile time	X	All Variants
	Link time	–	
	Post-build time	–	
Value Configuration Class	Pre-compile time	X	All Variants





	Link time	-	
	Post-build time	-	
Scope / Dependency	scope: ECU		

SWS Item	[ECUC_SwCluC_00150]
Parameter Name	SwCluCResourceRef
Parent Container	SwCluCDemProxyBaseSocket
Description	Reference to the CpSoftwareClusterServiceResource. Tags: atp.Status=draft
Multiplicity	1
Type	Foreign reference to CP-SOFTWARE-CLUSTER-SERVICE-RESOURCE
Scope / Dependency	scope: ECU

No Included Containers

[SWS_SwCluC_CONSTR_02720]{DRAFT} [SwCluCDemProxyBaseSocket](#) relates only to a [CpSoftwareClusterServiceResource](#) of category [SWCLUSTER_RES_DEM_BASE_SOCKET](#) [The [SwCluCDemProxyBaseSocket.SwCluCResourceRef](#) shall only reference a [CpSoftwareClusterServiceResource](#) of category [SWCLUSTER_RES_DEM_BASE_SOCKET](#).]()

10.2.7.6.2 Dem Proxy Diagnostic Event

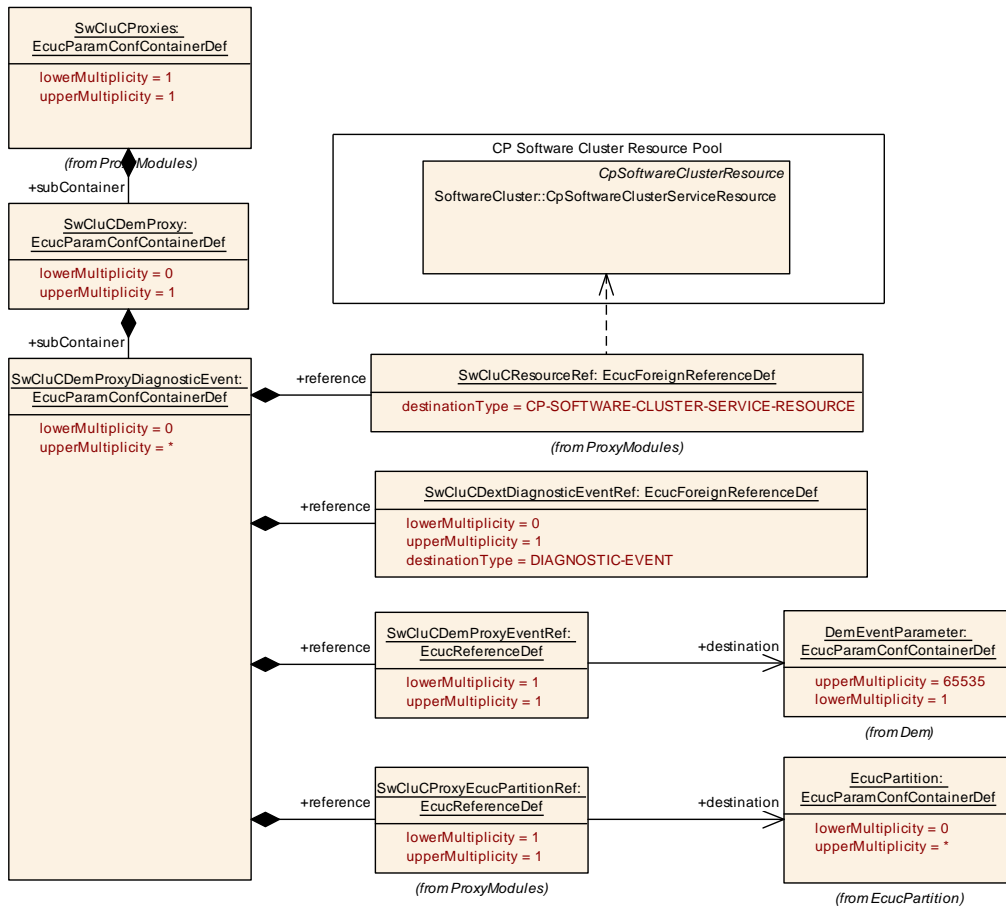

Figure 10.45: Dem Proxy Diagnostic Event

SWS Item	[ECUC_SwCluC_00116]		
Container Name	SwCluCDemProxyDiagnosticEvent		
Parent Container	SwCluCDemProxy		
Description	Configures a Diagnostic Event proxy. Tags: atp.Status=draft		
Multiplicity Configuration Class	Pre-compile time	X	All Variants
	Link time	–	
	Post-build time	–	
Configuration Parameters			

SWS Item	[ECUC_SwCluC_00117]		
Parameter Name	SwCluCDemProxyEventRef		
Parent Container	SwCluCDemProxyDiagnosticEvent		
Description	Reference to the diagnostic event of Dem Tags: atp.Status=draft		
Multiplicity	1		





Type	Reference to DemEventParameter
Scope / Dependency	scope: ECU

SWS Item	[ECUC_SwCluC_00140]
Parameter Name	SwCluCDEXTDiagnosticEventRef
Parent Container	SwCluCDemProxyDiagnosticEvent
Description	Reference to the Diagnostic Event in DEXT for back-tracing in case of DEXT based configuration approaches Tags: atp.Status=draft
Multiplicity	0..1
Type	Foreign reference to DIAGNOSTIC-EVENT
Scope / Dependency	scope: ECU

SWS Item	[ECUC_SwCluC_00059]		
Parameter Name	SwCluCProxyEcucPartitionRef		
Parent Container	SwCluCDemProxyDiagnosticEvent		
Description	Reference to the EcucPartition. Tags: atp.Status=draft		
Multiplicity	1		
Type	Reference to EcucPartition		
Multiplicity Configuration Class	Pre-compile time	X	All Variants
	Link time	–	
	Post-build time	–	
Value Configuration Class	Pre-compile time	X	All Variants
	Link time	–	
	Post-build time	–	
Scope / Dependency	scope: ECU		

SWS Item	[ECUC_SwCluC_00154]
Parameter Name	SwCluCResourceRef
Parent Container	SwCluCDemProxyDiagnosticEvent
Description	Reference to the CpSoftwareClusterServiceResource. Tags: atp.Status=draft
Multiplicity	1
Type	Foreign reference to CP-SOFTWARE-CLUSTER-SERVICE-RESOURCE
Scope / Dependency	scope: ECU

No Included Containers

[SWS_SwCluC_CONSTR_02721]{DRAFT} [SwCluCDemProxyDiagnosticEvent](#) relates only to a [CpSoftwareClusterServiceResource](#) of category [SWCLUSTER_RES_DEM_DIAGNOSTIC_EVENT](#) [The [SwCluCDemProxyDiagnosticEvent.SwCluCResourceRef](#) shall only reference a [CpSoftwareClusterServiceResource](#) of category [SWCLUSTER_RES_DEM_DIAGNOSTIC_EVENT](#).]()

10.2.7.7 FiM Proxy

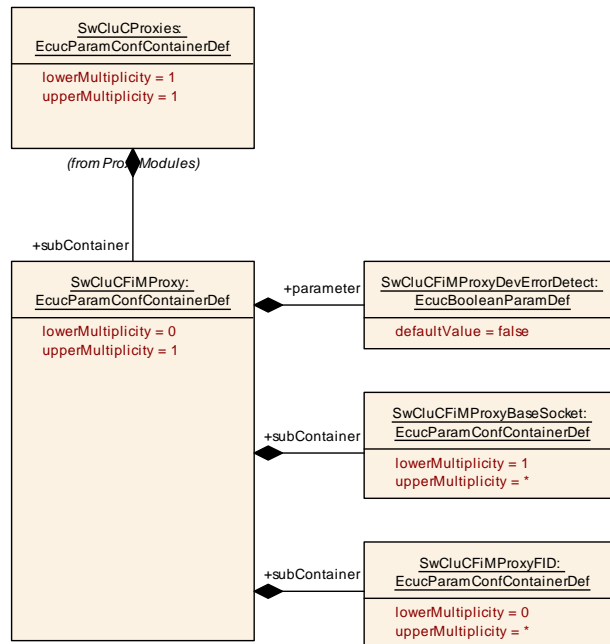

Figure 10.46: FiM Proxy Parameter

SWS Item	[ECUC_SwCluC_00105]		
Container Name	SwCluCFIMProxy		
Parent Container	SwCluCProxies		
Description	FiM Proxy specific parameters. Tags: atp.Status=draft		
Multiplicity Configuration Class	Pre-compile time	X	All Variants
	Link time	–	
	Post-build time	–	
Configuration Parameters			

SWS Item	[ECUC_SwCluC_00106]		
Parameter Name	SwCluCFIMProxyDevErrorDetect		
Parent Container	SwCluCFIMProxy		
Description	Switches the development error detection and notification on or off. <ul style="list-style-type: none"> • true: detection and notification is enabled. • false: detection and notification is disabled. Tags: atp.Status=draft		
Multiplicity	1		
Type	EcucBooleanParamDef		
Default value	false		
Post-Build Variant Value	false		
Value Configuration Class	Pre-compile time	X	All Variants
	Link time	–	
	Post-build time	–	





Scope / Dependency		scope: local
Included Containers		
Container Name	Multiplicity	Scope / Dependency
SwCluCFiMProxyBaseSocket	1..*	<p>This container configures how many EcucPartitions specific API links are required for the FiM Proxy and to which cluster resource the API set belongs.</p> <p>In the FiM Low Proxy all offered API sets needs to be configured. In the FiM High Proxy only the ones are configured which are offered inside this Application Software Cluster.</p> <p>The reference SwCluCProxyEcucPartitionRef denotes the Ecuc Partition on which the API set is provided.</p> <p>Tags: atp.Status=draft</p>
SwCluCFiMProxyFID	0..*	<p>Configures a Function Inhibition proxy.</p> <p>Tags: atp.Status=draft</p>

10.2.7.7.1 FiM Base Socket

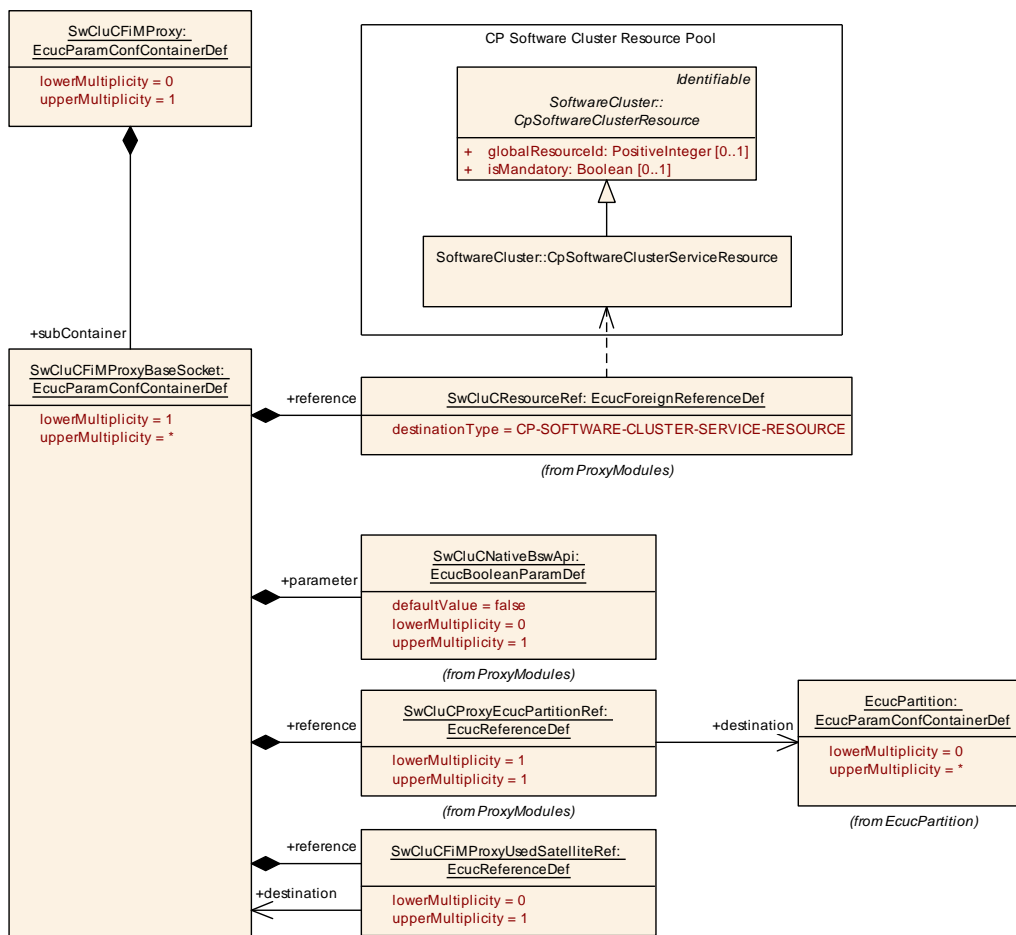

Figure 10.47: FiM Proxy Base Socket

SWS Item	[ECUC_SwCluC_00107]		
Container Name	SwCluCFiMProxyBaseSocket		
Parent Container	SwCluCFiMProxy		
Description	<p>This container configures how many EcucPartitions specific API links are required for the FiM Proxy and to which cluster resource the API set belongs.</p> <p>In the FiM Low Proxy all offered API sets needs to be configured. In the FiM High Proxy only the ones are configured which are offered inside this Application Software Cluster.</p> <p>The reference SwCluCProxyEcucPartitionRef denotes the EcucPartition on which the API set is provided.</p> <p>Tags: atp.Status=draft</p>		
Multiplicity Configuration Class	Pre-compile time	X	All Variants
	Link time	–	
	Post-build time	–	
Configuration Parameters			

SWS Item	[ECUC_SwCluC_00058]		
Parameter Name	SwCluCNativeBswApi		
Parent Container	SwCluCFiMProxyBaseSocket		
Description	<p>Defines if the native C-API without pre or suffixes is offered in the Application Software Cluster on this EcucPartition.</p> <p>This Parameter is only relevant for the NvM High Proxy.</p> <p>Tags: atp.Status=draft</p>		
Multiplicity	0..1		
Type	EcucBooleanParamDef		
Default value	false		
Post-Build Variant Value	false		
Multiplicity Configuration Class	Pre-compile time	X	All Variants
	Link time	–	
	Post-build time	–	
Value Configuration Class	Pre-compile time	X	All Variants
	Link time	–	
	Post-build time	–	
Scope / Dependency	scope: ECU		

SWS Item	[ECUC_SwCluC_00108]		
Parameter Name	SwCluCFiMProxyUsedSatelliteRef		
Parent Container	SwCluCFiMProxyBaseSocket		
Description	<p>Reference to the SwCluCFiMBaseSocket which has access to a satellite of the FiM. The owning SwCluCFiMBaseSocket uses the FiM satellite of the referenced SwCluCFiMBaseSocket.</p> <p>Tags: atp.Status=draft</p>		
Multiplicity	0..1		
Type	Reference to SwCluCFiMProxyBaseSocket		
Multiplicity Configuration Class	Pre-compile time	X	All Variants
	Link time	–	
	Post-build time	–	
Value Configuration Class	Pre-compile time	X	All Variants
	Link time	–	





	Post-build time	-	
Scope / Dependency	scope: ECU		

SWS Item	[ECUC_SwCluC_00059]		
Parameter Name	SwCluCProxyEcucPartitionRef		
Parent Container	SwCluCFiMProxyBaseSocket		
Description	Reference to the EcucPartition. Tags: atp.Status=draft		
Multiplicity	1		
Type	Reference to EcucPartition		
Multiplicity Configuration Class	Pre-compile time	X	All Variants
	Link time	-	
	Post-build time	-	
Value Configuration Class	Pre-compile time	X	All Variants
	Link time	-	
	Post-build time	-	
Scope / Dependency	scope: ECU		

SWS Item	[ECUC_SwCluC_00151]		
Parameter Name	SwCluCResourceRef		
Parent Container	SwCluCFiMProxyBaseSocket		
Description	Reference to the CpSoftwareClusterServiceResource. Tags: atp.Status=draft		
Multiplicity	1		
Type	Foreign reference to CP-SOFTWARE-CLUSTER-SERVICE-RESOURCE		
Scope / Dependency	scope: ECU		

No Included Containers

[SWS_SwCluC_CONSTR_03210]{DRAFT} [SwCluCFiMProxyBaseSocket](#) relates only to a [CpSoftwareClusterServiceResource](#) of category [SWCLUSTER_RES_FIM_BASE_SOCKET](#) [The [SwCluCFiMProxyBaseSocket.SwCluCResourceRef](#) shall only reference a [CpSoftwareClusterServiceResource](#) of category [SWCLUSTER_RES_FIM_BASE_SOCKET](#).]()

10.2.7.7.2 FiM Proxy FID

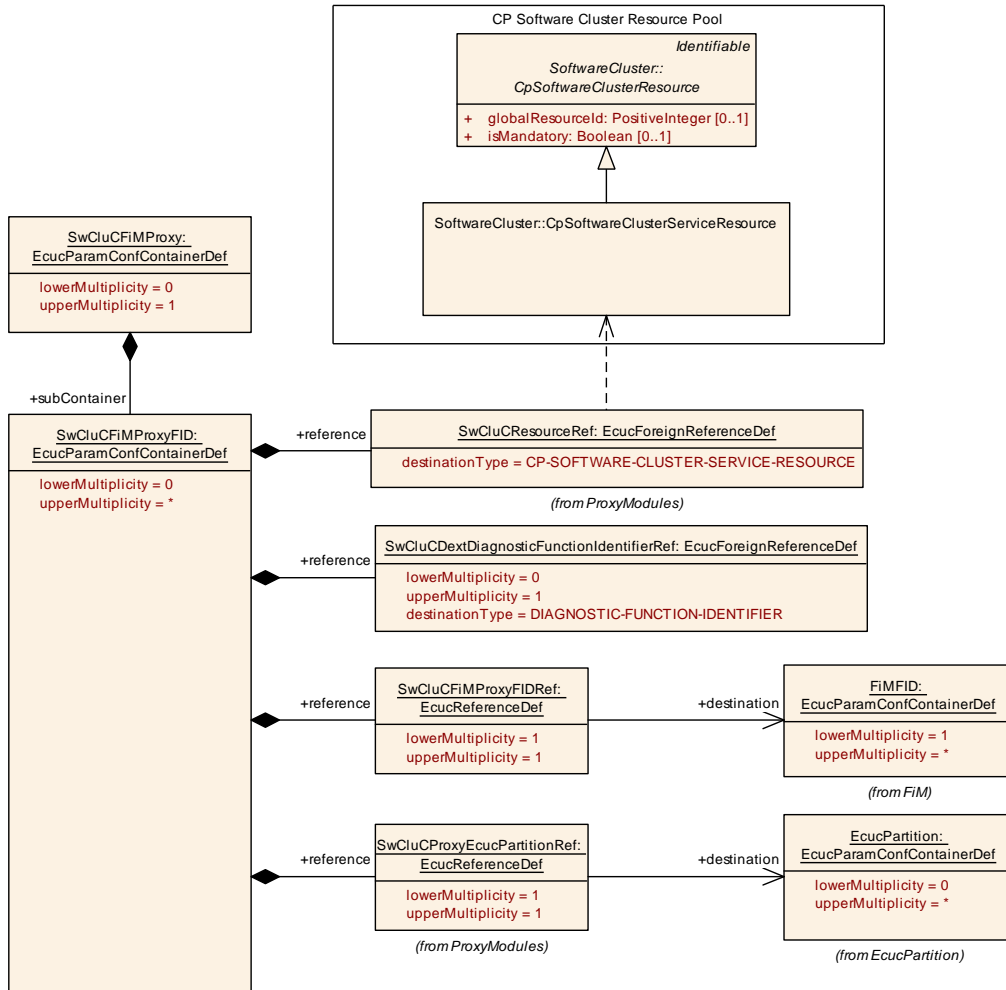

Figure 10.48: FiM Proxy FID

SWS Item	[ECUC_SwCluC_00109]		
Container Name	SwCluCFIMProxyFID		
Parent Container	SwCluCFIMProxy		
Description	Configures a Function Inhibition proxy. Tags: atp.Status=draft		
Multiplicity Configuration Class	Pre-compile time	X	All Variants
	Link time	-	
	Post-build time	-	
Configuration Parameters			

SWS Item	[ECUC_SwCluC_00142]		
Parameter Name	SwCluCxDextDiagnosticFunctionIdentifierRef		
Parent Container	SwCluCFIMProxyFID		





Description	Reference to the DiagnosticFunctionIdentifier in DEXT for back-tracing in case of DEXT based configuration approaches Tags: atp.Status=draft
Multiplicity	0..1
Type	Foreign reference to DIAGNOSTIC-FUNCTION-IDENTIFIER
Scope / Dependency	scope: ECU

SWS Item	[ECUC_SwCluC_00110]
Parameter Name	SwCluCFiMProxyFIDRef
Parent Container	SwCluCFiMProxyFID
Description	Reference to the FIMFID Tags: atp.Status=draft
Multiplicity	1
Type	Reference to FIMFID
Scope / Dependency	scope: ECU

SWS Item	[ECUC_SwCluC_00059]		
Parameter Name	SwCluCProxyEcucPartitionRef		
Parent Container	SwCluCFiMProxyFID		
Description	Reference to the EcucPartition. Tags: atp.Status=draft		
Multiplicity	1		
Type	Reference to EcucPartition		
Multiplicity Configuration Class	Pre-compile time	X	All Variants
	Link time	–	
	Post-build time	–	
Value Configuration Class	Pre-compile time	X	All Variants
	Link time	–	
	Post-build time	–	
Scope / Dependency	scope: ECU		

SWS Item	[ECUC_SwCluC_00141]
Parameter Name	SwCluCResourceRef
Parent Container	SwCluCFiMProxyFID
Description	Reference to the CpSoftwareClusterServiceResource. Tags: atp.Status=draft
Multiplicity	1
Type	Foreign reference to CP-SOFTWARE-CLUSTER-SERVICE-RESOURCE
Scope / Dependency	scope: ECU

No Included Containers

[SWS_SwCluC_CONSTR_03211]{DRAFT} [SwCluCFiMProxyFID](#) relates only to a [CpSoftwareClusterServiceResource](#) of category [SWCLUSTER_RES_FIM_FID](#) [The [SwCluCFiMProxyFID.SwCluCResourceRef](#) shall only reference a [CpSoftwareClusterServiceResource](#) of category [SWCLUSTER_RES_FIM_FID](#).]
()

10.3 Published Information

For details refer to the chapter 10.3 “Published Information” in SWS_BSWGeneral.

A Not applicable requirements

[SWS_SwCluC_NA_00999]{DRAFT} [These requirements are not applicable to this specification.] ([SRS_BSW_00344](#), [SRS_BSW_00404](#), [SRS_BSW_00405](#), [SRS_BSW_00170](#), [SRS_BSW_00380](#), [SRS_BSW_00419](#), [SRS_BSW_00438](#), [SRS_BSW_00375](#), [SRS_BSW_00416](#), [SRS_BSW_00406](#), [SRS_BSW_00467](#), [SRS_BSW_00437](#), [SRS_BSW_00168](#), [SRS_BSW_00423](#), [SRS_BSW_00424](#), [SRS_BSW_00425](#), [SRS_BSW_00426](#), [SRS_BSW_00427](#), [SRS_BSW_00432](#), [SRS_BSW_00433](#), [SRS_BSW_00450](#), [SRS_BSW_00461](#), [SRS_BSW_00451](#), [SRS_BSW_00478](#), [SRS_BSW_00339](#), [SRS_BSW_00422](#), [SRS_BSW_00417](#), [SRS_BSW_00409](#), [SRS_BSW_00452](#), [SRS_BSW_00458](#), [SRS_BSW_00466](#), [SRS_BSW_00488](#), [SRS_BSW_00469](#), [SRS_BSW_00470](#), [SRS_BSW_00471](#), [SRS_BSW_00472](#), [SRS_BSW_00473](#), [SRS_BSW_00161](#), [SRS_BSW_00162](#), [SRS_BSW_00005](#), [SRS_BSW_00415](#), [SRS_BSW_00164](#), [SRS_BSW_00325](#), [SRS_BSW_00342](#), [SRS_BSW_00343](#), [SRS_BSW_00160](#), [SRS_BSW_00453](#), [SRS_BSW_00456](#), [SRS_BSW_00457](#), [SRS_BSW_00479](#), [SRS_BSW_00483](#), [SRS_BSW_00007](#), [SRS_BSW_00413](#), [SRS_BSW_00347](#), [SRS_BSW_00307](#), [SRS_BSW_00373](#), [SRS_BSW_00335](#), [SRS_BSW_00410](#), [SRS_BSW_00411](#), [SRS_BSW_00463](#), [SRS_BSW_00481](#), [SRS_BSW_00346](#), [SRS_BSW_00314](#), [SRS_BSW_00447](#), [SRS_BSW_00348](#), [SRS_BSW_00353](#), [SRS_BSW_00301](#), [SRS_BSW_00302](#), [SRS_BSW_00328](#), [SRS_BSW_00312](#), [SRS_BSW_00006](#), [SRS_BSW_00439](#), [SRS_BSW_00448](#), [SRS_BSW_00449](#), [SRS_BSW_00357](#), [SRS_BSW_00377](#), [SRS_BSW_00304](#), [SRS_BSW_00378](#), [SRS_BSW_00306](#), [SRS_BSW_00308](#), [SRS_BSW_00309](#), [SRS_BSW_00484](#), [SRS_BSW_00485](#), [SRS_BSW_00486](#), [SRS_BSW_00414](#), [SRS_BSW_00359](#), [SRS_BSW_00360](#), [SRS_BSW_00440](#), [SRS_BSW_00330](#), [SRS_BSW_00331](#), [SRS_BSW_00454](#), [SRS_BSW_00477](#), [SRS_BSW_00459](#), [SRS_BSW_00460](#), [SRS_BSW_00336](#), [SRS_BSW_00351](#), [SRS_BSW_00383](#), [SRS_BSW_00384](#), [SRS_BSW_00386](#), [SRS_BSW_00388](#), [SRS_BSW_00389](#), [SRS_BSW_00345](#), [SRS_BSW_00390](#), [SRS_BSW_00392](#), [SRS_BSW_00393](#), [SRS_BSW_00394](#), [SRS_BSW_00395](#), [SRS_BSW_00396](#), [SRS_BSW_00399](#), [SRS_BSW_00401](#), [SRS_BSW_00403](#), [SRS_BSW_00462](#), [SRS_BSW_00490](#), [SRS_BSW_00492](#), [SRS_BSW_00494](#), [SRS_BSW_00493](#), [SRS_BSW_00491](#), [SRS_BSW_00489](#), [SRS_BSW_00465](#), [SRS_BSW_00464](#), [SRS_BSW_00429](#), [SRS_BSW_00408](#), [SRS_BSW_00402](#), [SRS_BSW_00400](#), [SRS_BSW_00398](#), [SRS_BSW_00397](#), [SRS_BSW_00379](#), [SRS_BSW_00374](#), [SRS_BSW_00341](#), [SRS_BSW_00318](#), [SRS_BSW_00321](#), [SRS_BSW_00300](#), [SRS_BSW_00171](#), [SRS_BSW_00159](#), [SRS_BSW_00010](#), [SRS_BSW_00009](#), [SRS_BSW_00004](#), [SRS_BSW_00003](#))

B Referenced Meta Classes

Class	AbstractAccessPoint (abstract)			
Package	M2::AUTOSARTemplates::SWComponentTemplate::SwcInternalBehavior::AccessCount			
Note	Abstract class indicating an access point from an ExecutableEntity.			
Base	ARObject, AtpClassifier, AtpFeature, AtpStructureElement, Identifiable , MultilanguageReferrable , Referrable			
Subclasses	AsynchronousServerCallResultPoint, ExternalTriggeringPointIdent, InternalTriggeringPoint, ModeAccessPointIdent, ModeSwitchPoint , ParameterAccess , ServerCallPoint , VariableAccess			
Aggregated by	AtpClassifier.atpFeature			
Attribute	Type	Mult.	Kind	Note
returnValue Provision	RteApiReturnValue ProvisionEnum	0..1	attr	This attribute controls the provision of return values for RTE APIs that correspond to the enclosing access point.

Table B.1: AbstractAccessPoint

Class	ApplicationArrayDataType			
Package	M2::AUTOSARTemplates::SWComponentTemplate::Datatype::Datatypes			
Note	An application data type which is an array, each element is of the same application data type. Tags: atp.recommendedPackage=ApplicationDataTypes			
Base	ARElement, ARObject, ApplicationCompositeDataType , ApplicationDataType , AtpBlueprint , AtpBlueprintable , AtpClassifier , AtpType , AutosarDataType , CollectableElement , Identifiable , MultilanguageReferrable , PackageableElement , Referrable			
Aggregated by	ARPackage.element			
Attribute	Type	Mult.	Kind	Note
dynamicArray SizeProfile	String	0..1	attr	Specifies the profile which the array will follow if it is a variable size array.
element	ApplicationArrayElement	0..1	aggr	This association implements the concept of an array element. That is, in some cases it is necessary to be able to identify single array elements, e.g. as input values for an interpolation routine.

Table B.2: ApplicationArrayDataType

Class	ApplicationArrayElement			
Package	M2::AUTOSARTemplates::SWComponentTemplate::Datatype::DataPrototypes			
Note	Describes the properties of the elements of an application array data type.			
Base	ARObject, ApplicationCompositeElementDataPrototype , AtpFeature , AtpPrototype , DataPrototype , Identifiable , MultilanguageReferrable , Referrable			
Aggregated by	ApplicationArrayDataType.element , AtpClassifier.atpFeature			
Attribute	Type	Mult.	Kind	Note
arraySize Handling	ArraySizeHandling Enum	0..1	attr	The way how the size of the array is handled.
arraySize Semantics	ArraySizeSemanticsEnum	0..1	attr	This attribute controls how the information about the array size shall be interpreted.
indexDataType	ApplicationPrimitiveDataType	0..1	ref	This reference can be taken to assign a CompuMethod of category TEXTTABLE to the array. The texttable entries associate a textual value to an index number such that the element with that index number is represented by a symbolic name.





Class	ApplicationArrayElement			
maxNumberOfElements	PositiveInteger	0..1	attr	The maximum number of elements that the array can contain. Stereotypes: atpVariation Tags: vh.latestBindingTime=preCompileTime

Table B.3: ApplicationArrayElement

Class	ApplicationCompositeElementDataPrototype (abstract)			
Package	M2::AUTOSARTemplates::SWComponentTemplate::Datatype::DataPrototypes			
Note	This class represents a data prototype which is aggregated within a composite application data type (record or array). It is introduced to provide a better distinction between target and context in instance Refs.			
Base	ARObject, AtpFeature, AtpPrototype, DataPrototype , Identifiable , MultilanguageReferrable , Referrable			
Subclasses	ApplicationArrayElement , ApplicationRecordElement			
Aggregated by	AtpClassifier.atpFeature			
Attribute	Type	Mult.	Kind	Note
type	ApplicationDataType	0..1	tref	This represents the corresponding data type. Stereotypes: isOfType

Table B.4: ApplicationCompositeElementDataPrototype

Class	ApplicationDataType (abstract)			
Package	M2::AUTOSARTemplates::SWComponentTemplate::Datatype::Datatypes			
Note	ApplicationDataType defines a data type from the application point of view. Especially it should be used whenever something "physical" is at stake. An ApplicationDataType represents a set of values as seen in the application model, such as measurement units. It does not consider implementation details such as bit-size, endianness, etc. It should be possible to model the application level aspects of a VFB system by using ApplicationDataTypes only.			
Base	ARElement, ARObject, AtpBlueprint, AtpBlueprintable, AtpClassifier, AtpType, AutosarDataType , CollectableElement , Identifiable , MultilanguageReferrable , PackageableElement , Referrable			
Subclasses	ApplicationCompositeDataType , ApplicationPrimitiveDataType			
Aggregated by	ARPackage.element			
Attribute	Type	Mult.	Kind	Note
–	–	–	–	–

Table B.5: ApplicationDataType

Class	ApplicationError			
Package	M2::AUTOSARTemplates::SWComponentTemplate::PortInterface			
Note	This is a user-defined error that is associated with an element of an AUTOSAR interface. It is specific for the particular functionality or service provided by the AUTOSAR software component.			
Base	ARObject, Identifiable , MultilanguageReferrable , Referrable			
Aggregated by	ClientServerInterface.possibleError			
Attribute	Type	Mult.	Kind	Note





Class	ApplicationError			
errorCode	Integer	0..1	attr	The RTE generator is forced to assign this value to the corresponding error symbol. Note that for error codes certain ranges are predefined (see RTE specification).

Table B.6: ApplicationError

Class	ApplicationPrimitiveDataType			
Package	M2::AUTOSARTemplates::SWComponentTemplate::Datatype::Datatypes			
Note	A primitive data type defines a set of allowed values. Tags: atp.recommendedPackage=ApplicationDataTypes			
Base	ARElement, ARObject, ApplicationDataType , AtpBlueprint, AtpBlueprintable, AtpClassifier, AtpType, AutosarDataType , CollectableElement, Identifiable , MultilanguageReferrable, PackageableElement, Referrable			
Aggregated by	ARPackage.element			
Attribute	Type	Mult.	Kind	Note
–	–	–	–	–

Table B.7: ApplicationPrimitiveDataType

Class	ApplicationRecordDataType			
Package	M2::AUTOSARTemplates::SWComponentTemplate::Datatype::Datatypes			
Note	An application data type which can be decomposed into prototypes of other application data types. Tags: atp.recommendedPackage=ApplicationDataTypes			
Base	ARElement, ARObject, ApplicationCompositeDataType , ApplicationDataType , AtpBlueprint, AtpBlueprintable, AtpClassifier, AtpType, AutosarDataType , CollectableElement , Identifiable , MultilanguageReferrable , PackageableElement , Referrable			
Aggregated by	ARPackage.element			
Attribute	Type	Mult.	Kind	Note
element (ordered)	ApplicationRecordElement	*	aggr	Specifies an element of a record. The aggregation of ApplicationRecordElement is subject to variability with the purpose to support the conditional existence of elements inside a ApplicationrecordDataType. Stereotypes: atpSplitable; atpVariation Tags: atp.Splitkey=element.shortName, element.variation Point.shortLabel vh.latestBindingTime=preCompileTime

Table B.8: ApplicationRecordDataType

Class	ApplicationRecordElement			
Package	M2::AUTOSARTemplates::SWComponentTemplate::Datatype::DataPrototypes			
Note	Describes the properties of one particular element of an application record data type.			
Base	ARObject, ApplicationCompositeElementDataPrototype , AtpFeature, AtpPrototype, DataPrototype , Identifiable , MultilanguageReferrable , Referrable			
Aggregated by	ApplicationRecordDataType.element , AtpClassifier.atpFeature			
Attribute	Type	Mult.	Kind	Note





Class	ApplicationRecordElement			
isOptional	Boolean	0..1	attr	<p>This attribute represents the ability to declare the enclosing ApplicationRecordElement as optional. This means the that, at runtime, the ApplicationRecordElement may or may not have a valid value and shall therefore be ignored.</p> <p>The underlying runtime software provides means to set the ApplicationRecordElement as not valid at the sending end of a communication and determine its validity at the receiving end.</p>

Table B.9: ApplicationRecordElement

Class	ArgumentDataPrototype			
Package	M2::AUTOSARTemplates::SWComponentTemplate::PortInterface			
Note	An argument of an operation, much like a data element, but also carries direction information and is owned by a particular ClientServerOperation.			
Base	ARObject, AtpFeature, AtpPrototype, AutosarDataPrototype, DataPrototype, Identifiable, Multilanguage Referrable, Referrable			
Aggregated by	AtpClassifier.atpFeature, ClientServerOperation.argument			
Attribute	Type	Mult.	Kind	Note
direction	ArgumentDirection Enum	0..1	attr	This attribute specifies the direction of the argument prototype.
serverArgument ImplPolicy	ServerArgumentImpl PolicyEnum	0..1	attr	<p>This defines how the argument type of the servers RunnableEntity is implemented.</p> <p>If the attribute is not defined this has the same semantics as if the attribute is set to the value useArgumentType for primitive arguments and structures.</p>

Table B.10: ArgumentDataPrototype

Enumeration	ArraySizeSemanticsEnum
Package	M2::AUTOSARTemplates::CommonStructure::ImplementationDataTypes
Note	This type controls how the information about the number of elements in an ApplicationArrayDataType is to be interpreted.
Aggregated by	ApplicationArrayElement.arraySizeSemantics, DiagnosticDataElement.arraySizeSemantics, ImplementationDataTypeElement.arraySizeSemantics, SwTextProps.arraySizeSemantics
Literal	Description
fixedSize	<p>This means that the ApplicationArrayDataType will always have a fixed number of elements.</p> <p>Tags:atp.EnumerationLiteralIndex=0</p>
variableSize	<p>This implies that the actual number of elements in the ApplicationArrayDataType might vary at run-time. The value of arraySize represents the maximum number of elements in the array.</p> <p>Tags:atp.EnumerationLiteralIndex=1</p>

Table B.11: ArraySizeSemanticsEnum

Class	AssemblySwConnector
Package	M2::AUTOSARTemplates::SWComponentTemplate::Composition
Note	AssemblySwConnectors are exclusively used to connect SwComponentPrototypes in the context of a CompositionSwComponentType.





Class	AssemblySwConnector			
Base	<i>ARObject</i> , <i>AtpClassifier</i> , <i>AtpFeature</i> , <i>AtpStructureElement</i> , Identifiable , MultilanguageReferrable , Referrable , <i>SwConnector</i>			
Aggregated by	<i>AtpClassifier</i> .atpFeature, CompositionSwComponentType.connector			
Attribute	Type	Mult.	Kind	Note
provider	AbstractProvidedPort Prototype	0..1	iref	Instance of providing port. InstanceRef implemented by: PPortInComposition InstanceRef
requester	AbstractRequiredPort Prototype	0..1	iref	Instance of requiring port. InstanceRef implemented by: RPortInComposition InstanceRef

Table B.12: AssemblySwConnector

Class	AsynchronousServerCallReturnsEvent			
Package	M2::AUTOSARTemplates::SWComponentTemplate::SwcInternalBehavior::RTEEvents			
Note	This event is raised when an asynchronous server call is finished.			
Base	<i>ARObject</i> , <i>AbstractEvent</i> , <i>AtpClassifier</i> , <i>AtpFeature</i> , <i>AtpStructureElement</i> , Identifiable , MultilanguageReferrable , RTEEvent , Referrable			
Aggregated by	<i>AtpClassifier</i> .atpFeature, SwcInternalBehavior.event			
Attribute	Type	Mult.	Kind	Note
eventSource	AsynchronousServer CallResultPoint	0..1	ref	The referenced AsynchronousServerCallResultPoint raises this AsynchronousServerCallReturnsEvent when the asynchronous server call returns.

Table B.13: AsynchronousServerCallReturnsEvent

Class	AutosarDataPrototype (abstract)			
Package	M2::AUTOSARTemplates::SWComponentTemplate::Datatype::DataPrototypes			
Note	Base class for prototypical roles of an AutosarDataType.			
Base	<i>ARObject</i> , <i>AtpFeature</i> , <i>AtpPrototype</i> , DataPrototype , Identifiable , MultilanguageReferrable , Referrable			
Subclasses	ArgumentDataPrototype , ParameterDataPrototype , VariableDataPrototype			
Aggregated by	<i>AtpClassifier</i> .atpFeature			
Attribute	Type	Mult.	Kind	Note
type	AutosarDataType	0..1	tref	This represents the corresponding data type. Stereotypes: isOfType

Table B.14: AutosarDataPrototype

Class	AutosarDataType (abstract)			
Package	M2::AUTOSARTemplates::SWComponentTemplate::Datatype::Datatypes			
Note	Abstract base class for user defined AUTOSAR data types for software.			
Base	<i>ARElement</i> , <i>ARObject</i> , <i>AtpClassifier</i> , <i>AtpType</i> , <i>CollectableElement</i> , Identifiable , MultilanguageReferrable , <i>PackageableElement</i> , Referrable			
Subclasses	<i>AbstractImplementationDataType</i> , ApplicationDataType			
Aggregated by	ARPackage.element			
Attribute	Type	Mult.	Kind	Note





Class	AutosarDataType (abstract)			
swDataDef Props	SwDataDefProps	0..1	aggr	The properties of this AutosarDataType. Stereotypes: atpSplitable Tags: atp.Splitkey=swDataDefProps

Table B.15: AutosarDataType

Class	BackgroundEvent			
Package	M2::AUTOSARTemplates::SWComponentTemplate::SwcInternalBehavior::RTEEvents			
Note	This event is used to start RunnableEntities that are supposed to be executed in the background.			
Base	ARObject, AbstractEvent, AtpClassifier, AtpFeature, AtpStructureElement, Identifiable , MultilanguageReferrable , RTEEvent , Referrable			
Aggregated by	AtpClassifier.atpFeature, SwcInternalBehavior.event			
Attribute	Type	Mult.	Kind	Note
–	–	–	–	–

Table B.16: BackgroundEvent

Class	BaseType (abstract)			
Package	M2::MSR::AsamHdo::BaseTypes			
Note	This abstract meta-class represents the ability to specify a platform dependent base type.			
Base	ARElement, ARObject, CollectableElement, Identifiable , MultilanguageReferrable , PackageableElement , Referrable			
Subclasses	SwBaseType			
Aggregated by	ARPackage.element			
Attribute	Type	Mult.	Kind	Note
baseType Definition	BaseTypeDefinition	1	aggr	This is the actual definition of the base type. Tags: xml.roleElement=false xml.roleWrapperElement=false xml.sequenceOffset=20 xml.typeElement=false xml.typeWrapperElement=false

Table B.17: BaseType

Class	BaseTypeDirectDefinition			
Package	M2::MSR::AsamHdo::BaseTypes			
Note	This BaseType is defined directly (as opposite to a derived BaseType)			
Base	ARObject, BaseTypeDefinition			
Aggregated by	BaseType.baseTypeDefinition			
Attribute	Type	Mult.	Kind	Note
baseType Encoding	BaseTypeEncoding String	0..1	attr	This specifies, how an object of the current BaseType is encoded, e.g. in an ECU within a message sequence. Tags: xml.sequenceOffset=90
baseTypeSize	PositiveInteger	0..1	attr	Describes the length of the data type specified in the container in bits. Tags: xml.sequenceOffset=70





Class	BaseTypeDirectDefinition			
byteOrder	ByteOrderEnum	0..1	attr	This attribute specifies the byte order of the base type. Tags: xml.sequenceOffset=110
memAlignment	PositiveInteger	0..1	attr	This attribute describes the alignment of the memory object in bits. E.g. "8" specifies, that the object in question is aligned to a byte while "32" specifies that it is aligned four byte. If the value is set to "0" the meaning shall be interpreted as "unspecified". Tags: xml.sequenceOffset=100
native Declaration	NativeDeclarationString	0..1	attr	This attribute describes the declaration of such a base type in the native programming language, primarily in the Programming language C. This can then be used by a code generator to include the necessary declarations into a header file. For example BaseType with shortName: "MyUnsignedInt" native Declaration: "unsigned short" Results in typedef unsigned short MyUnsignedInt; If the attribute is not defined the referring Implementation DataTypes will not be generated as a typedef by RTE. If a nativeDeclaration type is given it shall fulfill the characteristic given by basetypeEncoding and baseType Size. This is required to ensure the consistent handling and interpretation by software components, RTE, COM and MCM systems. Tags: xml.sequenceOffset=120

Table B.18: BaseTypeDirectDefinition

Class	BswEvent (abstract)			
Package	M2::AUTOSARTemplates::BswModuleTemplate::BswBehavior			
Note	Base class of various kinds of events which are used to trigger a BswModuleEntity of this BSW module or cluster. The event is local to the BSW module or cluster. The short name of the meta-class instance is intended as an input to configure the required API of the BSW Scheduler.			
Base	ARObject, AbstractEvent, Identifiable, MultilanguageReferrable, Referrable			
Subclasses	BswOperationInvokedEvent, BswScheduleEvent			
Aggregated by	BswInternalBehavior.event			
Attribute	Type	Mult.	Kind	Note
context Limitation	BswDistinguished Partition	*	ref	The existence of this reference indicates that the usage of the event is limited to the context of the referred Bsw DistinguishedPartitions.
disabledInMode	ModeDeclaration	*	iref	The modes, in which this event is disabled. Stereotypes: atpSplitable Tags: atp.Splitkey=disabledInMode.contextMode DeclarationGroup, disabledInMode.targetMode InstanceRef implemented by: ModeInBswModule DescriptionInstanceRef
startsOnEvent	BswModuleEntity	0..1	ref	The entity which is started by the event.

Table B.19: BswEvent

Class	BswExternalTriggerOccurredEvent			
Package	M2::AUTOSARTemplates::BswModuleTemplate::BswBehavior			
Note	A BswEvent resulting from a trigger released by another module or cluster.			
Base	ARObject, AbstractEvent, BswEvent , BswScheduleEvent, Identifiable , MultilanguageReferrable , Referrable			
Aggregated by	BswInternalBehavior.event			
Attribute	Type	Mult.	Kind	Note
trigger	Trigger	0..1	ref	The trigger associated with this event. The trigger is external to this module.

Table B.20: BswExternalTriggerOccurredEvent

Class	BswInternalTriggerOccurredEvent			
Package	M2::AUTOSARTemplates::BswModuleTemplate::BswBehavior			
Note	A BswEvent, which can happen sporadically. The event is activated by explicit calls from the module to the BSW Scheduler. The main purpose for such an event is to cause a context switch, e.g. from an ISR context into a task context. Activation and switching are handled within the same module or cluster only.			
Base	ARObject, AbstractEvent, BswEvent , BswScheduleEvent, Identifiable , MultilanguageReferrable , Referrable			
Aggregated by	BswInternalBehavior.event			
Attribute	Type	Mult.	Kind	Note
eventSource	BswInternalTriggering Point	0..1	ref	The activation point is the source of this event.

Table B.21: BswInternalTriggerOccurredEvent

Class	BswModeSwitchEvent			
Package	M2::AUTOSARTemplates::BswModuleTemplate::BswBehavior			
Note	A BswEvent resulting from a mode switch.			
Base	ARObject, AbstractEvent, BswEvent , BswScheduleEvent, Identifiable , MultilanguageReferrable , Referrable			
Aggregated by	BswInternalBehavior.event			
Attribute	Type	Mult.	Kind	Note
activation	ModeActivationKind	0..1	attr	Kind of activation w.r.t. to the referred mode.
mode (ordered)	ModeDeclaration	0..2	iref	Reference to one or two Modes that initiate the Mode Switch Event. InstanceRef implemented by: ModeInBswModule DescriptionInstanceRef

Table B.22: BswModeSwitchEvent

Class	BswModuleDescription			
Package	M2::AUTOSARTemplates::BswModuleTemplate::BswOverview			
Note	Root element for the description of a single BSW module or BSW cluster. In case it describes a BSW module, the short name of this element equals the name of the BSW module. Tags: atp.recommendedPackage=BswModuleDescriptions			
Base	ARElement, ARObject, AtpBlueprint, AtpBlueprintable, AtpClassifier, AtpFeature, AtpStructureElement, CollectableElement, Identifiable , MultilanguageReferrable , PackageableElement , Referrable			
Aggregated by	ARPackage.element, AtpClassifier.atpFeature			
Attribute	Type	Mult.	Kind	Note





Class	BswModuleDescription			
bswModule Dependency	BswModuleDependency	*	aggr	<p>Describes the dependency to another BSW module.</p> <p>Stereotypes: atpSplitable; atpVariation Tags: atp.Splitkey=bswModuleDependency.shortName, bswModuleDependency.variationPoint.shortLabel vh.latestBindingTime=preCompileTime xml.sequenceOffset=20</p>
bswModule Documentation	SwComponent Documentation	0..1	aggr	<p>This adds a documentation to the BSW module.</p> <p>Stereotypes: atpSplitable; atpVariation Tags: atp.Splitkey=bswModuleDocumentation, bswModuleDocumentation.variationPoint.shortLabel vh.latestBindingTime=preCompileTime xml.sequenceOffset=6</p>
expectedEntry	BswModuleEntry	*	ref	<p>Indicates an entry which is required by this module. Replacement of outgoingCallback / requiredEntry.</p> <p>Stereotypes: atpSplitable; atpVariation Tags: atp.Splitkey=expectedEntry.bswModuleEntry, expectedEntry.variationPoint.shortLabel vh.latestBindingTime=preCompileTime</p>
implemented Entry	BswModuleEntry	*	ref	<p>Specifies an entry provided by this module which can be called by other modules. This includes "main" functions, interrupt routines, and callbacks. Replacement of providedEntry / expectedCallback.</p> <p>Stereotypes: atpSplitable; atpVariation Tags: atp.Splitkey=implementedEntry.bswModuleEntry, implementedEntry.variationPoint.shortLabel vh.latestBindingTime=preCompileTime</p>
internalBehavior	BswInternalBehavior	*	aggr	<p>The various BswInternalBehaviors associated with a BswModuleDescription can be distributed over several physical files. Therefore the aggregation is <<atpSplitable>>.</p> <p>Stereotypes: atpSplitable Tags: atp.Splitkey=internalBehavior.shortName xml.sequenceOffset=65</p>
moduleId	PositiveInteger	0..1	attr	<p>Refers to the BSW Module Identifier defined by the AUTOSAR standard. For non-standardized modules, a proprietary identifier can be optionally chosen.</p> <p>Tags:xml.sequenceOffset=5</p>
providedClient ServerEntry	BswModuleClientServer Entry	*	aggr	<p>Specifies that this module provides a client server entry which can be called from another partition or core. This entry is declared locally to this context and will be connected to the requiredClientServerEntry of another or the same module via the configuration of the BSW Scheduler.</p> <p>Stereotypes: atpSplitable; atpVariation Tags: atp.Splitkey=providedClientServerEntry.shortName, providedClientServerEntry.variationPoint.shortLabel vh.latestBindingTime=preCompileTime xml.sequenceOffset=45</p>





Class	BswModuleDescription			
providedData	VariableDataPrototype	*	aggr	<p>Specifies a data prototype provided by this module in order to be read from another partition or core. The providedData is declared locally to this context and will be connected to the requiredData of another or the same module via the configuration of the BSW Scheduler.</p> <p>Stereotypes: atpSplitable; atpVariation Tags: atp.Splitkey=providedData.shortName, providedData.variationPoint.shortLabel vh.latestBindingTime=preCompileTime xml.sequenceOffset=55</p>
providedMode Group	ModeDeclarationGroup Prototype	*	aggr	<p>A set of modes which is owned and provided by this module or cluster. It can be connected to the required ModeGroups of other modules or clusters via the configuration of the BswScheduler. It can also be synchronized with modes provided via ports by an associated ServiceSwComponentType, EcuAbstraction SwComponentType or ComplexDeviceDriverSw ComponentType.</p> <p>Stereotypes: atpSplitable; atpVariation Tags: atp.Splitkey=providedModeGroup.shortName, provided ModeGroup.variationPoint.shortLabel vh.latestBindingTime=preCompileTime xml.sequenceOffset=25</p>
releasedTrigger	Trigger	*	aggr	<p>A Trigger released by this module or cluster. It can be connected to the requiredTriggers of other modules or clusters via the configuration of the BswScheduler. It can also be synchronized with Triggers provided via ports by an associated ServiceSwComponentType, Ecu AbstractionSwComponentType or ComplexDeviceDriver SwComponentType.</p> <p>Stereotypes: atpSplitable; atpVariation Tags: atp.Splitkey=releasedTrigger.shortName, released Trigger.variationPoint.shortLabel vh.latestBindingTime=preCompileTime xml.sequenceOffset=35</p>
requiredClient ServerEntry	BswModuleClientServer Entry	*	aggr	<p>Specifies that this module requires a client server entry which can be implemented on another partition or core. This entry is declared locally to this context and will be connected to the providedClientServerEntry of another or the same module via the configuration of the BSW Scheduler.</p> <p>Stereotypes: atpSplitable; atpVariation Tags: atp.Splitkey=requiredClientServerEntry.shortName, requiredClientServerEntry.variationPoint.shortLabel vh.latestBindingTime=preCompileTime xml.sequenceOffset=50</p>





Class	BswModuleDescription			
requiredData	VariableDataPrototype	*	aggr	<p>Specifies a data prototype required by this module in order to be provided from another partition or core. The required Data is declared locally to this context and will be connected to the providedData of another or the same module via the configuration of the BswScheduler.</p> <p>Stereotypes: atpSplitable; atpVariation Tags: atp.Splitkey=requiredData.shortName, requiredData.variationPoint.shortLabel vh.latestBindingTime=preCompileTime xml.sequenceOffset=60</p>
requiredMode Group	ModeDeclarationGroup Prototype	*	aggr	<p>Specifies that this module or cluster depends on a certain mode group. The requiredModeGroup is local to this context and will be connected to the providedModeGroup of another module or cluster via the configuration of the BswScheduler.</p> <p>Stereotypes: atpSplitable; atpVariation Tags: atp.Splitkey=requiredModeGroup.shortName, requiredModeGroup.variationPoint.shortLabel vh.latestBindingTime=preCompileTime xml.sequenceOffset=30</p>
requiredTrigger	Trigger	*	aggr	<p>Specifies that this module or cluster reacts upon an external trigger. This requiredTrigger is declared locally to this context and will be connected to the providedTrigger of another module or cluster via the configuration of the BswScheduler.</p> <p>Stereotypes: atpSplitable; atpVariation Tags: atp.Splitkey=requiredTrigger.shortName, requiredTrigger.variationPoint.shortLabel vh.latestBindingTime=preCompileTime xml.sequenceOffset=40</p>

Table B.23: BswModuleDescription

Class	<i>BswModuleEntity</i> (abstract)			
Package	M2::AUTOSARTemplates::BswModuleTemplate::BswBehavior			
Note	Specifies the smallest code fragment which can be described for a BSW module or cluster within AUTOSAR.			
Base	<i>ARObject</i> , ExecutableEntity , Identifiable , MultilanguageReferrable , Referrable			
Subclasses	BswCalledEntity , BswInterruptEntity , BswSchedulableEntity			
Aggregated by	BswInternalBehavior.entity			
Attribute	Type	Mult.	Kind	Note
accessedMode Group	ModeDeclarationGroup Prototype	*	ref	<p>A mode group which is accessed via API call by this entity. It shall be a ModeDeclarationGroupPrototype required by this module or cluster.</p> <p>Stereotypes: atpSplitable; atpVariation Tags: atp.Splitkey=accessedModeGroup.modeDeclarationGroupPrototype, accessedModeGroup.variationPoint.shortLabel vh.latestBindingTime=preCompileTime</p>





<i>Class</i>	<i>BswModuleEntity</i> (abstract)			
activationPoint	BswInternalTriggeringPoint	*	ref	<p>Activation point used by the module entity to activate one or more internal triggers.</p> <p>Stereotypes: atpSplitable; atpVariation Tags: atp.Splitkey=activationPoint.bswInternalTriggeringPoint, activationPoint.variationPoint.shortLabel vh.latestBindingTime=preCompileTime</p>
callPoint	BswModuleCallPoint	*	aggr	<p>A call point used in the code of this entity.</p> <p>The variability of this association is especially targeted at debug scenarios: It is possible to have one variant calling into the AUTOSAR debug module and another one which doesn't.</p> <p>Stereotypes: atpSplitable; atpVariation Tags: atp.Splitkey=callPoint.shortName, callPoint.variationPoint.shortLabel vh.latestBindingTime=preCompileTime</p>
dataReceivePoint	BswVariableAccess	*	aggr	<p>The data is received via the BSW Scheduler.</p> <p>Stereotypes: atpSplitable; atpVariation Tags: atp.Splitkey=dataReceivePoint.shortName, dataReceivePoint.variationPoint.shortLabel vh.latestBindingTime=preCompileTime</p>
dataSendPoint	BswVariableAccess	*	aggr	<p>The data is sent via the BSW Scheduler.</p> <p>Stereotypes: atpSplitable; atpVariation Tags: atp.Splitkey=dataSendPoint.shortName, dataSendPoint.variationPoint.shortLabel vh.latestBindingTime=preCompileTime</p>
implementedEntry	BswModuleEntry	0..1	ref	<p>The entry which is implemented by this module entity.</p>
issuedTrigger	Trigger	*	ref	<p>A trigger issued by this entity via BSW Scheduler API call. It shall be a BswTrigger released (i.e. owned) by this module or cluster.</p> <p>Stereotypes: atpSplitable; atpVariation Tags: atp.Splitkey=issuedTrigger.trigger, issuedTrigger.variationPoint.shortLabel vh.latestBindingTime=preCompileTime</p>
managedModeGroup	ModeDeclarationGroupPrototype	*	ref	<p>A mode group which is managed by this entity. It shall be a ModeDeclarationGroupPrototype provided by this module or cluster.</p> <p>Stereotypes: atpSplitable; atpVariation Tags: atp.Splitkey=managedModeGroup.modeDeclarationGroupPrototype, managedModeGroup.variationPoint.shortLabel vh.latestBindingTime=preCompileTime</p>
schedulerNamePrefix	BswSchedulerNamePrefix	0..1	ref	<p>A prefix to be used in generated names for the BswModuleScheduler in the context of this BswModuleEntity, for example entry point prototypes, macros for dealing with exclusive areas, header file names.</p> <p>Details are defined in the SWS RTE.</p> <p>The prefix supersedes default rules for the prefix of those names.</p>

Table B.24: BswModuleEntity

Class	BswSchedulableEntity			
Package	M2::AUTOSARTemplates::BswModuleTemplate::BswBehavior			
Note	BSW module entity, which is designed for control by the BSW Scheduler. It may for example implement a so-called "main" function.			
Base	<i>ARObject</i> , <i>BswModuleEntity</i> , <i>ExecutableEntity</i> , <i>Identifiable</i> , <i>MultilanguageReferrable</i> , <i>Referrable</i>			
Aggregated by	BswInternalBehavior.entity			
Attribute	Type	Mult.	Kind	Note
–	–	–	–	–

Table B.25: BswSchedulableEntity

Class	BswTimingEvent			
Package	M2::AUTOSARTemplates::BswModuleTemplate::BswBehavior			
Note	A recurring BswEvent driven by a time period.			
Base	<i>ARObject</i> , <i>AbstractEvent</i> , <i>BswEvent</i> , <i>BswScheduleEvent</i> , <i>Identifiable</i> , <i>MultilanguageReferrable</i> , <i>Referrable</i>			
Aggregated by	BswInternalBehavior.event			
Attribute	Type	Mult.	Kind	Note
period	TimeValue	0..1	attr	Requirement for the time period (in seconds) by which this event is triggered.

Table B.26: BswTimingEvent

Class	BswVariableAccess			
Package	M2::AUTOSARTemplates::BswModuleTemplate::BswBehavior			
Note	The presence of a BswVariableAccess implies that a BswModuleEntity needs access to a VariableData Prototype via the BSW Scheduler. The kind of access is specified by the role in which the class is used.			
Base	<i>ARObject</i> , <i>Referrable</i>			
Aggregated by	<i>BswModuleEntity.dataReceivePoint</i> , <i>BswModuleEntity.dataSendPoint</i>			
Attribute	Type	Mult.	Kind	Note
accessed Variable	<i>VariableDataPrototype</i>	0..1	ref	The data accessed via the BSW Scheduler.
context Limitation	BswDistinguished Partition	*	ref	The existence of this reference indicates that the variable is received resp. sent only in the context of the referred BswDistinguishedPartitions.

Table B.27: BswVariableAccess

Class	ClientServerApplicationErrorMapping			
Package	M2::AUTOSARTemplates::SWComponentTemplate::PortInterface			
Note	This meta-class represents the ability to map ApplicationErrors onto each other.			
Base	<i>ARObject</i>			
Aggregated by	ClientServerInterfaceMapping.errorMapping			
Attribute	Type	Mult.	Kind	Note
firstApplication Error	<i>ApplicationError</i>	0..1	ref	This represents the first ApplicationError in the context of the ClientServerApplicationErrorMapping.
second ApplicationError	<i>ApplicationError</i>	0..1	ref	This represents the second ApplicationError in the context of the ClientServerApplicationErrorMapping.

Table B.28: ClientServerApplicationErrorMapping

Class	ClientServerInterface			
Package	M2::AUTOSARTemplates::SWComponentTemplate::PortInterface			
Note	A client/server interface declares a number of operations that can be invoked on a server by a client. Tags: atp.recommendedPackage=PortInterfaces			
Base	<i>ARElement, ARObject, AtpBlueprint, AtpBlueprintable, AtpClassifier, AtpType, CollectableElement, Identifiable, MultilanguageReferrable, PackageableElement, PortInterface, Referrable</i>			
Aggregated by	ARPackage.element			
Attribute	Type	Mult.	Kind	Note
operation	ClientServerOperation	*	aggr	ClientServerOperation(s) of this ClientServerInterface. Stereotypes: atpSplitable; atpVariation Tags: atp.Splitkey=operation.shortName, operation.variation Point.shortLabel vh.latestBindingTime=blueprintDerivationTime
possibleError	ApplicationError	*	aggr	Application errors that are defined as part of this interface.

Table B.29: ClientServerInterface

Class	ClientServerOperation			
Package	M2::AUTOSARTemplates::SWComponentTemplate::PortInterface			
Note	An operation declared within the scope of a client/server interface.			
Base	<i>ARObject, AtpClassifier, AtpFeature, AtpStructureElement, Identifiable, MultilanguageReferrable, Referrable</i>			
Aggregated by	ApplicationInterface.command, <i>AtpClassifier.atpFeature</i> , ClientServerInterface.operation , DiagnosticDataElementInterface.read, DiagnosticDataIdentifierInterface.read, DiagnosticDataIdentifierInterface.write, DiagnosticRoutineInterface.requestResult, DiagnosticRoutineInterface.start, DiagnosticRoutineInterface.stop, PhmRecoveryActionInterface.recovery, ServiceInterface.method			
Attribute	Type	Mult.	Kind	Note
argument (ordered)	ArgumentDataPrototype	*	aggr	An argument of this ClientServerOperation Stereotypes: atpSplitable; atpVariation Tags: atp.Splitkey=argument.shortName, argument.variation Point.shortLabel vh.latestBindingTime=blueprintDerivationTime
diagArgIntegrity	Boolean	0..1	attr	This attribute shall only be used in the implementation of diagnostic routines to support the case where input and output arguments are allocated in a shared buffer and might unintentionally overwrite input arguments by tentative write operations to output arguments. This situation can happen during sliced execution or while output parameters are arrays (call by reference). The value true means that the ClientServerOperation is aware of the usage of a shared buffer and takes precautions to avoid unintentional overwrite of input arguments. If the attribute does not exist or is set to false the Client ServerOperation does not have to consider the usage of a shared buffer.
possibleError	ApplicationError	*	ref	Possible errors that may be raised by the referring operation.

Table B.30: ClientServerOperation

Class	ClientServerOperationComProps			
Package	M2::AUTOSARTemplates::SystemTemplate::SoftwareCluster			
Note	Defines additional attributes for the implementation of Client Server communication between software clusters Tags: atp.Status=draft			
Base	ARObject, CpSoftwareClusterCommunicationResourceProps			
Aggregated by	CpSoftwareClusterCommunicationResource.communicationResourceProps			
Attribute	Type	Mult.	Kind	Note
queueLength	PositiveInteger	0..1	attr	Length of call request queue on the server side. The queue is implemented by the SwCluC. The value shall be greater or equal to 1. Setting the value of queueLength to 1 implies that incoming requests are rejected while another request that arrived earlier is being processed. Tags: atp.Status=draft

Table B.31: ClientServerOperationComProps

Class	ClientServerOperationMapping			
Package	M2::AUTOSARTemplates::SWComponentTemplate::PortInterface			
Note	Defines the mapping of two particular ClientServerOperations in context of two different ClientServer Interfaces.			
Base	ARObject			
Aggregated by	ClientServerInterfaceMapping.operationMapping			
Attribute	Type	Mult.	Kind	Note
argument Mapping	DataPrototypeMapping	*	aggr	Defines the mapping of two particular ArgumentData Prototypes with unequal names or unequal semantic (resolution or range) in context of Operations.
firstOperation	ClientServerOperation	0..1	ref	First to-be-mapped ClientServerOperation of a Client ServerInterface.
firstToSecond Data Transformation	DataTransformation	0..1	ref	This reference indicates that a DataTransformation is intended in the context of the ClientServerOperation Mapping.
second Operation	ClientServerOperation	0..1	ref	Second to-be-mapped ClientServerOperation of a Client ServerInterface.

Table B.32: ClientServerOperationMapping

Class	CompositionSwComponentType			
Package	M2::AUTOSARTemplates::SWComponentTemplate::Composition			
Note	A CompositionSwComponentType aggregates SwComponentPrototypes (that in turn are typed by Sw ComponentTypes) as well as SwConnectors for primarily connecting SwComponentPrototypes among each others and towards the surface of the CompositionSwComponentType. By this means, hierarchical structures of software-components can be created. Tags: atp.recommendedPackage=SwComponentTypes			
Base	ARElement, ARObject, AtpBlueprint, AtpBlueprintable, AtpClassifier, AtpType, CollectableElement, Identifiable, MultilanguageReferrable, PackageableElement, Referrable, SwComponentType			
Aggregated by	ARPackage.element			
Attribute	Type	Mult.	Kind	Note





Class	CompositionSwComponentType			
component	SwComponent Prototype	*	aggr	<p>The instantiated components that are part of this composition. The aggregation of SwComponentPrototype is subject to variability with the purpose to support the conditional existence of a SwComponentPrototype. Please be aware: if the conditional existence of SwComponentPrototypes is resolved post-build the deselected SwComponentPrototypes are still contained in the ECUs build but the instances are inactive in that they are not scheduled by the RTE.</p> <p>The aggregation is marked as atpSplitable in order to allow the addition of service components to the ECU extract during the ECU integration.</p> <p>The use case for having 0 components owned by the CompositionSwComponentType could be to deliver an empty CompositionSwComponentType to e.g. a supplier for filling the internal structure.</p> <p>Stereotypes: atpSplitable; atpVariation Tags: atp.Splitkey=component.shortName, component.variation Point.shortLabel vh.latestBindingTime=postBuild</p>
connector	SwConnector	*	aggr	<p>SwConnectors have the principal ability to establish a connection among PortPrototypes. They can have many roles in the context of a CompositionSwComponentType. Details are refined by subclasses.</p> <p>The aggregation of SwConnectors is subject to variability with the purpose to support variant data flow.</p> <p>The aggregation is marked as atpSplitable in order to allow the extension of the ECU extract with AssemblySwConnectors between ApplicationSwComponentTypes and ServiceSwComponentTypes during the ECU integration.</p> <p>Stereotypes: atpSplitable; atpVariation Tags: atp.Splitkey=connector.shortName, connector.variation Point.shortLabel vh.latestBindingTime=postBuild</p>
constantValue Mapping	ConstantSpecification MappingSet	*	ref	<p>Reference to the ConstantSpecificationMapping to be applied for initValues of PPortComSpecs and RPortComSpec.</p> <p>Stereotypes: atpSplitable Tags:atp.Splitkey=constantValueMapping</p>





Class	CompositionSwComponentType			
dataTypeMapping	DataTypeMappingSet	*	ref	<p>Reference to the DataTypeMapping to be applied for the used ApplicationDataTypes in PortInterfaces.</p> <p>Background: when developing subsystems it may happen that ApplicationDataTypes are used on the surface of CompositionSwComponentTypes. In this case it would be reasonable to be able to also provide the intended mapping to the ImplementationDataTypes. However, this mapping shall be informal and not technically binding for the implementors mainly because the RTE generator is not concerned about the CompositionSwComponentTypes.</p> <p>Rationale: if the mapping of ApplicationDataTypes on the delegated and inner PortPrototype matches then the mapping to ImplementationDataTypes is not impacting compatibility.</p> <p>Stereotypes: atpSplittable Tags: atp.Splitkey=dataTypeMapping</p>
instantiationRTEEventProps	InstantiationRTEEventProps	*	aggr	<p>This allows to define instantiation specific properties for RTE Events, in particular for instance specific scheduling.</p> <p>Stereotypes: atpSplittable; atpVariation Tags: atp.Splitkey=instantiationRTEEventProps.shortLabel, instantiationRTEEventProps.variationPoint.shortLabel vh.latestBindingTime=codeGenerationTime</p>

Table B.33: CompositionSwComponentType

Class	Compu			
Package	M2::MSR::AsamHdo::ComputationMethod			
Note	This meta-class represents the ability to express one particular computation.			
Base	ARObject			
Aggregated by	CompuMethod.compuInternalToPhys , CompuMethod.compuPhysToInternal			
Attribute	Type	Mult.	Kind	Note
compuContent	CompuContent	0..1	aggr	<p>This specifies the details of the computation.</p> <p>Tags: xml.roleElement=false xml.roleWrapperElement=false xml.sequenceOffset=20 xml.typeElement=false xml.typeWrapperElement=false</p>
compuDefaultValue	CompuConst	0..1	aggr	<p>This property can be used to specify an output value for a conversion formula, if the value to be converted lies outside the plausibility limit. Although this is possible for all conversion formulae, it is especially valid for variables with tabular conversion formulae.</p> <p>Tags:xml.sequenceOffset=70</p>

Table B.34: Compu

Class	CompuConstFormulaContent			
Package	M2::MSR::AsamHdo::ComputationMethod			
Note	This meta-class represents the fact that the constant value of the computation method is represented by a variation point. This difference is due to compatibility with ASAM HDO.			





Class	CompuConstFormulaContent			
Base	<i>ARObject, CompuConstContent</i>			
Aggregated by	CompuConst.compuConstContentType			
Attribute	Type	Mult.	Kind	Note
vf	Numerical	1	attr	<p>Value calculated via a system constant. This element is included in every case where parameters should be generated from numerical values during compile time (not runtime!).</p> <p>Thus for example, the influence of the cylinder number on conversion formulae can be introduced in a repeatable manner.</p> <p>Stereotypes: atpVariation Tags: vh.latestBindingTime=codeGenerationTime xml.sequenceOffset=30</p>

Table B.35: CompuConstFormulaContent

Class	CompuConstTextContent			
Package	M2::MSR::AsamHdo::ComputationMethod			
Note	This meta-class represents the textual content of a scale.			
Base	<i>ARObject, CompuConstContent</i>			
Aggregated by	CompuConst.compuConstContentType			
Attribute	Type	Mult.	Kind	Note
vt	VerbatimString	0..1	attr	This represents a textual constant in the computation method.

Table B.36: CompuConstTextContent

Class	CompuMethod			
Package	M2::MSR::AsamHdo::ComputationMethod			
Note	<p>This meta-class represents the ability to express the relationship between a physical value and the mathematical representation.</p> <p>Note that this is still independent of the technical implementation in data types. It only specifies the formula how the internal value corresponds to its physical pendant.</p> <p>Tags:atp.recommendedPackage=CompuMethods</p>			
Base	<i>ARElement, ARObject, AtpBlueprint, AtpBlueprintable, CollectableElement, Identifiable, Multilanguage Referrable, PackageableElement, Referrable</i>			
Aggregated by	ARPackage.element			
Attribute	Type	Mult.	Kind	Note
compuInternalToPhys	Compu	0..1	aggr	<p>This specifies the computation from internal values to physical values.</p> <p>Tags:xml.sequenceOffset=80</p>
compuPhysToInternal	Compu	0..1	aggr	<p>This represents the computation from physical values to the internal values.</p> <p>Tags:xml.sequenceOffset=90</p>





Class	CompuMethod			
displayFormat	DisplayFormatString	0..1	attr	This property specifies, how the physical value shall be displayed e.g. in documents or measurement and calibration tools. Tags: xml.sequenceOffset=20
unit	Unit	0..1	ref	This is the physical unit of the Physical values for which the CompuMethod applies. Tags: xml.sequenceOffset=30

Table B.37: CompuMethod

Class	CompuNominatorDenominator			
Package	M2::MSR::AsamHdo::ComputationMethod			
Note	This class represents the ability to express a polynomial either as Nominator or as Denominator.			
Base	ARObject			
Aggregated by	CompuRationalCoeffs.compuDenominator , CompuRationalCoeffs.compuNumerator			
Attribute	Type	Mult.	Kind	Note
v (ordered)	Numerical	*	attr	this is the list of polynomial factors. Note that the first vf represents the power=0. The polynomial is v[0] * x^0 + v[1] * x^1 ... Stereotypes: atpVariation Tags: vh.latestBindingTime=preCompileTime xml.roleElement=true xml.roleWrapperElement=false xml.sequenceOffset=20 xml.typeElement=false xml.typeWrapperElement=false

Table B.38: CompuNominatorDenominator

Class	CompuRationalCoeffs			
Package	M2::MSR::AsamHdo::ComputationMethod			
Note	This meta-class represents the ability to express a rational function by specifying the coefficients of nominator and denominator.			
Base	ARObject			
Aggregated by	CompuScaleRationalFormula.compuRationalCoeffs			
Attribute	Type	Mult.	Kind	Note
compu Denominator	CompuNominatorDenominator	0..1	aggr	This is the denominator of the expression. Tags: xml.sequenceOffset=30
compu Numerator	CompuNominatorDenominator	0..1	aggr	This is the numerator of the rational expression. Tags: xml.sequenceOffset=20

Table B.39: CompuRationalCoeffs

Class	CompuScale			
Package	M2::MSR::AsamHdo::ComputationMethod			
Note	This meta-class represents the ability to specify one segment of a segmented computation method.			
Base	ARObject			





Class		CompuScale		
Aggregated by		CompuScales.compuScale		
Attribute	Type	Mult.	Kind	Note
compuInverse Value	CompuConst	0..1	aggr	This is the inverse value of the constraint. This supports the case that the scale is not reversible per se. Tags: xml.sequenceOffset=60
compuScale Contents	CompuScaleContents	0..1	aggr	This represents the computation details of the scale. Tags: xml.roleElement=false xml.roleWrapperElement=false xml.sequenceOffset=70 xml.typeElement=false xml.typeWrapperElement=false
desc	MultiLanguageOverview Paragraph	0..1	aggr	<desc> represents a general but brief description of the object in question. Tags: xml.sequenceOffset=30
lowerLimit	Limit	0..1	attr	This specifies the lower limit of the scale. Stereotypes: atpVariation Tags: vh.latestBindingTime=preCompileTime xml.sequenceOffset=40
mask	PositiveUnlimitedInteger	0..1	attr	In difference to all the other computational methods every COMPU-SCALE will be applied including the bit MASK. Therefore it is allowed for this type of COMPU-METHOD, that COMPU-SCALES overlap. To calculate the string reverse to a value, the string has to be split and the according value for each substring has to be summed up. The sum is finally transmitted. The processing has to be done in order of the COMPU-SCALE elements. Tags: xml.sequenceOffset=35
shortLabel	Identifier	0..1	attr	This element specifies a short name for the particular scale. The name can for example be used to derive a programming language identifier. Tags: xml.sequenceOffset=20
symbol	CIdentifier	0..1	attr	The symbol, if provided, is used by code generators to get a C identifier for the CompuScale. The name will be used as is for the code generation, therefore it needs to be unique within the generation context. Tags: xml.sequenceOffset=25
upperLimit	Limit	0..1	attr	This specifies the upper limit of a of the scale. Stereotypes: atpVariation Tags: vh.latestBindingTime=preCompileTime xml.sequenceOffset=50

Table B.40: CompuScale

Class		CompuScaleConstantContents
Package		M2::MSR::AsamHdo::ComputationMethod
Note		This meta-class represents the fact that a particular scale of the computation method is constant.
Base		<i>ARObject, CompuScaleContents</i>





Class	CompuScaleConstantContents			
Aggregated by	CompuScale.compuScaleContents			
Attribute	Type	Mult.	Kind	Note
compuConst	CompuConst	0..1	aggr	This represents the fact that the scale is a constant. The use case is mainly a non interpolated scale. It is a simplification of the fact that a constant scale can also be expressed as rational function of order 0. Tags: xml.sequenceOffset=90

Table B.41: CompuScaleConstantContents

Class	CompuScales			
Package	M2::MSR::AsamHdo::ComputationMethod			
Note	This meta-class represents the ability to stepwise express a computation method.			
Base	<i>ARObject</i> , <i>CompuContent</i>			
Aggregated by	Compu.compuContent			
Attribute	Type	Mult.	Kind	Note
compuScale (ordered)	CompuScale	*	aggr	This represents one scale within the compu method. Note that it contains a Variationpoint in order to support blueprints of enumerations. Stereotypes: atpSplitable; atpVariation Tags: atp.Splitkey=compuScale, compuScale.variationPoint.shortLabel vh.latestBindingTime=blueprintDerivationTime xml.roleElement=true xml.roleWrapperElement=true xml.sequenceOffset=40 xml.typeElement=false xml.typeWrapperElement=false

Table B.42: CompuScales

Class	CpSoftwareCluster			
Package	M2::AUTOSARTemplates::SystemTemplate::SoftwareCluster			
Note	This meta class provides the ability to define a CP Software Cluster. Each CP Software Cluster can be integrated and build individually. It defines the sub-set of hierarchical tree(s) of Software Components belonging to this CP Software Cluster. Resources required or provided by this CP Software Cluster are given in the according mappings. Tags: atp.Status=draft atp.recommendedPackage=CpSoftwareClusters			
Base	<i>ARElement</i> , <i>ARObject</i> , <i>CollectableElement</i> , <i>Identifiable</i> , <i>MultilanguageReferrable</i> , <i>PackageableElement</i> , <i>Referrable</i>			
Aggregated by	ARPackage.element			
Attribute	Type	Mult.	Kind	Note
softwareClusterId	PositiveInteger	0..1	attr	This attribute represents the value of the id of the corresponding CP software cluster.





Class	CpSoftwareCluster			
swComponent Assignment	SwComponent PrototypeAssignment	*	aggr	<p>This is the collection of SwComponentPrototype Assignments</p> <p>Stereotypes: atpSplitable; atpVariation</p> <p>Tags: atp.Splitkey=swComponentAssignment, swComponent Assignment.variationPoint.shortLabel atp.Status=draft vh.latestBindingTime=postBuild</p>
swComposition	CompositionSw ComponentType	*	ref	<p>Software Components in the context of a CompositionSw ComponentType belonging to this CP Software Cluster. This reference can be used to describe the belonging SWCs when the CP Software Cluster is described out of the context of a System, e.g. reusable CP Software Cluster.</p> <p>Stereotypes: atpSplitable; atpVariation</p> <p>Tags: atp.Splitkey=swComposition.compositionSwComponent Type, swComposition.variationPoint.shortLabel atp.Status=draft vh.latestBindingTime=systemDesignTime</p>

Table B.43: CpSoftwareCluster

Class	CpSoftwareClusterBinaryManifestDescriptor			
Package	M2::AUTOSARTemplates::SystemTemplate::SoftwareCluster::BinaryManifest			
Note	<p>This meta-class has the ability to act as a hub for all information related to the binary manifest of a given CP software cluster. The manifest is subject to integrator work and therefore not a part of the definition of the CP software cluster itself.</p> <p>Tags: atp.Status=draft atp.recommendedPackage=CpSoftwareClusterBinaryManifestDescriptors</p>			
Base	<i>ARElement, ARObject, CollectableElement, Identifiable, MultilanguageReferrable, Packageable Element, Referrable</i>			
Aggregated by	ARPackage.element			
Attribute	Type	Mult.	Kind	Note
cpSoftware Cluster	CpSoftwareCluster	0..1	ref	<p>This reference identifies the CpSoftwareCluster to which the enclosing CpSoftwareClusterBinaryManifest Descriptor belongs,</p> <p>The CpSoftwareClusterBinaryManifestDescriptor is defined in an integration phase while the referenced Cp SoftwareCluster represents a design element. Therefore, it makes sense to use a reference rather than an aggregation in the relation of the two meta-classes.</p> <p>Tags:atp.Status=draft</p>
metaDataField	BinaryManifestMeta DataField	*	aggr	<p>This aggregation identifies the collection of meta-data contained in the enclosing binary manifest.</p> <p>Tags:atp.Status=draft</p>
provide Resource	BinaryManifestProvide Resource	*	aggr	<p>This aggregation represents the collection of provided resources in the enclosing binary manifest.</p> <p>Tags:atp.Status=draft</p>
require Resource	BinaryManifestRequire Resource	*	aggr	<p>This aggregation represents the collection of required resources in the enclosing binary manifest.</p> <p>Tags:atp.Status=draft</p>





Class		CpSoftwareClusterBinaryManifestDescriptor		
resource Definition	BinaryManifest ResourceDefinition	*	aggr	This aggregation represents the collection of binary manifest resource definitions that belong to the enclosing CpSoftwareClusterBinaryManifestDescriptor. Tags: atp.Status=draft
softwareCluster Id	PositiveInteger	0..1	attr	This attribute represents the value of the id of the corresponding CP software cluster. This id is assigned by an integrator, but may also be copied from CpSoftwareCluster.softwareClusterId if available. Tags: atp.Status=draft

Table B.44: CpSoftwareClusterBinaryManifestDescriptor

Class		CpSoftwareClusterCommunicationResource		
Package	M2::AUTOSARTemplates::SystemTemplate::SoftwareCluster			
Note	Represents a single resource required or provided by a CP Software Cluster which relates to the port based communication on VFB level. Tags: atp.Status=draft			
Base	<i>ARObject</i> , <i>CpSoftwareClusterResource</i> , <i>Identifiable</i> , <i>MultilanguageReferrable</i> , <i>Referrable</i>			
Aggregated by	CpSoftwareClusterResourcePool.resource			
Attribute	Type	Mult.	Kind	Note
communication ResourceProps	CpSoftwareCluster Communication ResourceProps	0..1	aggr	This aggregation supports the further qualification of the enclosing CpSoftwareClusterCommunicationResource by means of additional attributes depending on the nature of the CpSoftwareClusterCommunicationResource.

Table B.45: CpSoftwareClusterCommunicationResource

Class		CpSoftwareClusterResource (abstract)		
Package	M2::AUTOSARTemplates::SystemTemplate::SoftwareCluster			
Note	Represents a single resource required or provided by a CP Software Cluster. Tags: atp.Status=draft atp.recommendedPackage=Resources			
Base	<i>ARObject</i> , <i>Identifiable</i> , <i>MultilanguageReferrable</i> , <i>Referrable</i>			
Subclasses	CpSoftwareClusterCommunicationResource , CpSoftwareClusterServiceResource			
Aggregated by	CpSoftwareClusterResourcePool.resource			
Attribute	Type	Mult.	Kind	Note
dependent Resource	RoleBasedResource Dependency	*	aggr	Link to a resource which depends on this resource to implement them. Tags: atp.Status=draft
globalResource Id	PositiveInteger	0..1	attr	A unique identifiers per resource used for the connection process. The identifier is required to be unique in the scope of a single machine. If software clusters are designed to be reused on multiple machines the uniqueness requirements applies for all the intended machines. Tags: atp.Status=draft





Class	CpSoftwareClusterResource (abstract)			
isMandatory	Boolean	0..1	attr	This attribute indicates, that the resource is mandatory to operate the Software Cluster. If the resource is not provided on the machine the connection process of any Software Cluster requiring this resource gets aborted. Tags: atp.Status=draft

Table B.46: CpSoftwareClusterResource

Class	CpSoftwareClusterResourcePool			
Package	M2::AUTOSARTemplates::SystemTemplate::SoftwareCluster			
Note	Represents the pool of resources which can be provided or required by CP Software Clusters. Tags: atp.Status=draft atp.recommendedPackage=CpSoftwareClusterResourcePools			
Base	ARElement, ARObject, CollectableElement, Identifiable, MultilanguageReferrable, PackageableElement, Referrable			
Aggregated by	ARPackage.element			
Attribute	Type	Mult.	Kind	Note
ecuScope	EcuInstance	*	ref	This reference identifies the EcuInstance in which the resource pool is defined. Stereotypes: atpSplitable Tags: atp.Splitkey=ecuScope atp.Status=draft
resource	CpSoftwareClusterResource	*	aggr	This aggregation represents the collection of resources in the enclosing resource pool. Stereotypes: atpSplitable Tags: atp.Splitkey=resource.shortName atp.Status=draft

Table B.47: CpSoftwareClusterResourcePool

Class	CpSoftwareClusterServiceResource			
Package	M2::AUTOSARTemplates::SystemTemplate::SoftwareCluster			
Note	Represents a single resource required or provided by a CP Software Cluster which relates to the BSW. Tags: atp.Status=draft			
Base	ARObject, CpSoftwareClusterResource, Identifiable, MultilanguageReferrable, Referrable			
Aggregated by	CpSoftwareClusterResourcePool.resource			
Attribute	Type	Mult.	Kind	Note
resourceNeeds	EcucContainerValue	*	ref	Reference(s) to one or multiple EcucContainerValue(s) qualifying the characteristics of the resource. Tags: atp.Status=draft

Table B.48: CpSoftwareClusterServiceResource

Class	DataComProps			
Package	M2::AUTOSARTemplates::SystemTemplate::SoftwareCluster			
Note	Represents a single resource required or provided by a CP Software Cluster which relates to the port based communication on VFB level. Tags: atp.Status=draft			
Base	ARObject, CpSoftwareClusterCommunicationResourceProps			
Aggregated by	CpSoftwareClusterCommunicationResource.communicationResourceProps			
Attribute	Type	Mult.	Kind	Note
data Consistency Policy	DataConsistencyPolicy Enum	0..1	attr	This attribute defines requirements on the data consistency mechanism in the cross cluster communication. If the attribute is not set, the default value consistencyMechanismRequired applies. Tags: atp.Status=draft
sendIndication	SendIndicationEnum	0..1	attr	Send indication behavior for last-is-the best data communication.

Table B.49: DataComProps

Enumeration	DataConsistencyPolicyEnum
Package	M2::AUTOSARTemplates::SystemTemplate::SoftwareCluster
Note	Defines how data consistency is ensured in the cross cluster communication.
Aggregated by	DataComProps.dataConsistencyPolicy
Literal	Description
consistency Mechanism Required	In this case the data consistency is ensured by the implementation of the SwClucC module. Tags: atp.EnumerationLiteralIndex=0
noConsistency Mechanism	In this case the data consistency is not ensured by the SwClucC module. In this case it has to be ensured by scheduling. Tags: atp.EnumerationLiteralIndex=1

Table B.50: DataConsistencyPolicyEnum

Class	DataConstr			
Package	M2::MSR::AsamHdo::Constraints::GlobalConstraints			
Note	This meta-class represents the ability to specify constraints on data. Tags: atp.recommendedPackage=DataConstrs			
Base	ARElement, ARObject, AtpBlueprint, AtpBlueprintable, CollectableElement, Identifiable, Multilanguage Referrable, PackageableElement, Referrable			
Aggregated by	ARPackage.element			
Attribute	Type	Mult.	Kind	Note
dataConstrRule	DataConstrRule	*	aggr	This is one particular rule within the data constraints. Tags: xml.roleElement=true xml.roleWrapperElement=true xml.sequenceOffset=30 xml.typeElement=false xml.typeWrapperElement=false

Table B.51: DataConstr

Class	DataConstrRule			
Package	M2::MSR::AsamHdo::Constraints::GlobalConstraints			
Note	This meta-class represents the ability to express one specific data constraint rule.			
Base	ARObject			
Aggregated by	DataConstr.dataConstrRule			
Attribute	Type	Mult.	Kind	Note
constrLevel	Integer	0..1	attr	This attribute describes the category of a constraint. One of its functions is in the area of constraint violation, where it can be used from a certain level, to produce error messages. The lower the level, the more stringent the check. Used to distinguish hard or soft limits. Tags: xml.sequenceOffset=20
internalConstrs	InternalConstrs	0..1	aggr	Describes the limitations applicable on the internal domain (as opposed to the physical domain). Tags: xml.sequenceOffset=40
physConstrs	PhysConstrs	0..1	aggr	Describes the limitations applicable on the physical domain (as opposed to the internal domain). Tags: xml.sequenceOffset=30

Table B.52: DataConstrRule

Class	DataMapping (abstract)			
Package	M2::AUTOSARTemplates::SystemTemplate::DataMapping			
Note	Mapping of port elements (data elements and parameters) to frames and signals.			
Base	ARObject			
Subclasses	ClientServerToSignalMapping, SenderReceiverCompositeElementToSignalMapping, SenderReceiverToSignalGroupMapping, SenderReceiverToSignalMapping, TriggerToSignalMapping			
Aggregated by	SystemMapping.dataMapping			
Attribute	Type	Mult.	Kind	Note
introduction	DocumentationBlock	0..1	aggr	This represents introductory documentation about the data mapping.

Table B.53: DataMapping

Class	DataPrototype (abstract)			
Package	M2::AUTOSARTemplates::SWComponentTemplate::Datatype::DataPrototypes			
Note	Base class for prototypical roles of any data type.			
Base	ARObject, AtpFeature, AtpPrototype, Identifiable , MultilanguageReferrable , Referrable			
Subclasses	ApplicationCompositeElementDataPrototype , AutosarDataPrototype			
Aggregated by	AtpClassifier.atpFeature			
Attribute	Type	Mult.	Kind	Note
swDataDef Props	SwDataDefProps	0..1	aggr	This property allows to specify data definition properties which apply on data prototype level. Stereotypes: atpSplitable Tags: atp.Splitkey=swDataDefProps

Table B.54: DataPrototype

Class	DataReceivedEvent			
Package	M2::AUTOSARTemplates::SWComponentTemplate::SwcInternalBehavior::RTEEvents			
Note	This event is raised when the referenced data element is received.			
Base	ARObject, AbstractEvent, AtpClassifier, AtpFeature, AtpStructureElement, Identifiable, MultilanguageReferrable, RTEEvent, Referrable			
Aggregated by	AtpClassifier.atpFeature, SwcInternalBehavior.event			
Attribute	Type	Mult.	Kind	Note
data	VariableDataPrototype	0..1	iref	The referenced VariableDataPrototype raises this DataReceivedEvent when the data has been received. InstanceRef implemented by: RVVariableInAtomicSwc InstanceRef

Table B.55: DataReceivedEvent

Class	DiagnosticEventInfoNeeds			
Package	M2::AUTOSARTemplates::CommonStructure::ServiceNeeds			
Note	This meta-class represents the needs of a software-component interested to get information regarding specific DTCs.			
Base	ARObject, DiagnosticCapabilityElement, Identifiable, MultilanguageReferrable, Referrable, ServiceNeeds			
Aggregated by	BswServiceDependency.serviceNeeds, SwcServiceDependency.serviceNeeds			
Attribute	Type	Mult.	Kind	Note
obdDtcNumber	PositiveInteger	0..1	attr	This represents a reasonable Diagnostic Trouble Code. This allows to predefine the Diagnostic Trouble Code, e.g. if the function developer has received a particular requirement from the OEM or from a standardization body. This attribute applies for the OBD diagnostics use case.
udsDtcNumber	PositiveInteger	0..1	attr	This represents a reasonable Diagnostic Trouble Code. This allows to predefine the Diagnostic Trouble Code, e.g. if the function developer has received a particular requirement from the OEM or from a standardization body. This attribute applies for the UDS diagnostics use case.

Table B.56: DiagnosticEventInfoNeeds

Class	DiagnosticEventNeeds			
Package	M2::AUTOSARTemplates::CommonStructure::ServiceNeeds			
Note	Specifies the abstract needs on the configuration of the Diagnostic Event Manager for one diagnostic event. Its shortName can be regarded as a symbol identifying the diagnostic event from the viewpoint of the component or module which owns this element. In case the diagnostic event specifies a production error, the shortName shall be the name of the production error.			
Base	ARObject, DiagnosticCapabilityElement, Identifiable, MultilanguageReferrable, Referrable, ServiceNeeds			
Aggregated by	BswServiceDependency.serviceNeeds, SwcServiceDependency.serviceNeeds			
Attribute	Type	Mult.	Kind	Note
deferringFid	FunctionInhibitionNeeds	*	ref	This reference contains the link to a function identifier within the FiM which is used by the monitor before delivering a result.





Class	DiagnosticEventNeeds			
diagEventDebounceAlgorithm	DiagEventDebounceAlgorithm	0..1	aggr	Specifies the abstract need on the Debounce Algorithm applied by the Diagnostic Event Manager.
inhibitingFid	FunctionInhibitionNeeds	0..1	ref	This represents the primary Function Inhibition Identifier used for inhibition of the diagnostic monitor. The FID might either inhibit the monitoring of a symptom or the reporting of detected faults.
inhibitingSecondaryFid	FunctionInhibitionNeeds	*	ref	This represents the secondary Function Inhibition Identifier used for inhibition of the diagnostic monitor. Any of the FID inhibitions leads to an inhibition of the monitoring of a symptom or the reporting of detected faults.
prestoredFreezeFrameStoredInNvm	Boolean	0..1	attr	If the Event uses a prestored freeze-frame (using the operations <code>PrestoreFreezeFrame</code> and <code>ClearPrestoredFreezeFrame</code> of the service interface <code>DiagnosticMonitor</code>) this attribute indicates if the Event requires the data to be stored in non-volatile memory. TRUE = Dem shall store the prestored data in non-volatile memory, FALSE = Data can be lost at shutdown (not stored in Nvm).
usesMonitorData	Boolean	0..1	attr	This attribute defines whether additional monitor data shall be added to the reporting of events.

Table B.57: DiagnosticEventNeeds

Class	EcuInstance			
Package	M2::AUTOSARTemplates::SystemTemplate::Fibex::FibexCore::CoreTopology			
Note	ECUInstances are used to define the ECUs used in the topology. The type of the ECU is defined by a reference to an ECU specified with the ECU resource description. Tags: atp.recommendedPackage=EcuInstances			
Base	ARObject , CollectableElement , FibexElement , Identifiable , MultilanguageReferrable , PackageableElement , Referrable			
Aggregated by	ARPackage.element			
Attribute	Type	Mult.	Kind	Note
associatedCommunicationPduGroup	ISignalPduGroup	*	ref	With this reference it is possible to identify which ISignalPduGroups are applicable for which Communication Connector/ ECU. Only top level ISignalPduGroups shall be referenced by an EcuInstance. If an ISignalPduGroup contains other ISignalPduGroups than these contained ISignalPduGroups shall not be referenced by the EcuInstance. Contained ISignalPduGroups are associated to an Ecu Instance via the top level ISignalPduGroup.
associatedConsumedProvidedServiceInstanceGroup	ConsumedProvidedServiceInstanceGroup	*	ref	With this reference it is possible to identify which ConsumedProvidedServiceInstanceGroups are applicable for which ECUInstance. Stereotypes: atpSplittable; atpVariation Tags: atp.Splitkey=associatedConsumedProvidedServiceInstanceGroup.consumedProvidedServiceInstanceGroup, associatedConsumedProvidedServiceInstanceGroup.variationPoint.shortLabel vh.latestBindingTime=postBuild
associatedPduRIPduGroup	PduRIPduGroup	*	ref	With this reference it is possible to identify which PduRIPdu Groups are applicable for which Communication Connector/ ECU.





Class	EcuInstance			
clientIdRange	ClientIdRange	0..1	aggr	Restriction of the Client Identifier for this Ecu to an allowed range of numerical values. The Client Identifier of the transaction handle is generated by the client RTE for inter-Ecu Client/Server communication.
com Configuration GwTimeBase	TimeValue	0..1	attr	The period between successive calls to Com_Main FunctionRouteSignals of the AUTOSAR COM module in seconds.
com ConfigurationRx TimeBase	TimeValue	0..1	attr	The period between successive calls to Com_Main FunctionRx of the AUTOSAR COM module in seconds.
com ConfigurationTx TimeBase	TimeValue	0..1	attr	The period between successive calls to Com_Main FunctionTx of the AUTOSAR COM module in seconds.
comEnable MDTForCyclic Transmission	Boolean	0..1	attr	Enables for the Com module of this EcuInstance the minimum delay time monitoring for cyclic and repeated transmissions (TransmissionModeTiming has cyclic Timing assigned or eventControlledTiming with numberOfRepetitions > 0).
commController	Communication Controller	1..*	aggr	CommunicationControllers of the ECU. Stereotypes: atpSplitable; atpVariation Tags: atp.Splitkey=commController.shortName, commController.variationPoint.shortLabel vh.latestBindingTime=postBuild
connector	Communication Connector	*	aggr	All channels controlled by a single controller. Stereotypes: atpSplitable; atpVariation Tags: atp.Splitkey=connector.shortName, connector.variationPoint.shortLabel vh.latestBindingTime=postBuild
dltConfig	DltConfig	0..1	aggr	Describes the Dlt configuration on this EcuInstance.
dolpConfig	DolpConfig	0..1	aggr	Dolp configuration on this EcuInstance. Tags: atp.Status=draft
ecuTaskProxy	OsTaskProxy	*	ref	Reference to OsTaskProxies assigned to the Ecu Instance. Stereotypes: atpSplitable Tags: atp.Splitkey=ecuTaskProxy
ethSwitchPort Group Derivation	Boolean	0..1	attr	Defines whether the derivation of SwitchPortGroups based on VLAN and/or CouplingPort.pncMapping shall be performed for this EcuInstance. If not defined the derivation shall not be done.
partition	EcuPartition	*	aggr	Optional definition of Partitions within an Ecu.
pncNmRequest	Boolean	0..1	attr	Defines if this EcuInstance shall request Nm on all its PhysicalChannels which have Nm variant set to FULL each time a PNC is requested.
pncPrepare SleepTimer	TimeValue	0..1	attr	Time in seconds the PNC state machine shall wait in PNC_PREPARE_SLEEP.
pnc Synchronous Wakeup	Boolean	0..1	attr	If this parameter is available and set to true then all available PNCs will be woken up as soon as a channel wakeup occurs. This is ensured by adding all PNCs to all channel wakeup sources during upstream mapping.
pnResetTime	TimeValue	0..1	attr	Specifies the runtime of the reset timer in seconds. This reset time is valid for the reset of PN requests in the EIRA and in the ERA.





Class	EcuInstance			
sleepModeSupported	Boolean	1	attr	Specifies whether the ECU instance may be put to a "low power mode" <ul style="list-style-type: none"> • true: sleep mode is supported • false: sleep mode is not supported Note: This flag may only be set to "true" if the feature is supported by both hardware and basic software.
tcpIcmpProps	EthTcpIcmpProps	0..1	ref	EcuInstance specific ICMP (Internet Control Message Protocol) attributes
tcpIProps	EthTcpIProps	0..1	ref	EcuInstance specific TcpI Stack attributes.
v2xSupported	V2xSupportEnum	0..1	attr	This attribute is used to control the existence of the V2X stack on the given EcuInstance.
wakeUpOverBusSupported	Boolean	1	attr	Driver support for wakeup over Bus.

Table B.58: EcuInstance

Class	EcucContainerDef (abstract)			
Package	M2::AUTOSARTemplates::ECUCParameterDefTemplate			
Note	Base class used to gather common attributes of configuration container definitions.			
Base	ARObject, AtpDefinition, EcucDefinitionElement, Identifiable , MultilanguageReferrable , Referrable			
Subclasses	EcucChoiceContainerDef, EcucParamConfContainerDef			
Aggregated by	EcucDestinationUriPolicy.container, EcucModuleDef.container , EcucParamConfContainerDef.subContainer			
Attribute	Type	Mult.	Kind	Note
destinationUri	EcucDestinationUriDef	*	ref	Several destinationUris can be defined for an Ecuc ContainerDef. With such destinationUris an Ecuc ContainerDef is applicable for several EcucUriReference Defs. Stereotypes: atpUriDef
multiplicityConfigClass	EcucMultiplicityConfigurationClass	*	aggr	Specifies which MultiplicityConfigurationClass this container is available for which ConfigurationVariant. This aggregation is optional if the surrounding EcucModuleDef has the Category STANDARDIZED_MODULE_DEFINITION. If the category attribute of the EcucModuleDef is set to VENDOR_SPECIFIC_MODULE_DEFINITION and if the upperMultiplicity is greater than the lowerMultiplicity then this aggregation is mandatory. Tags: xml.name Plural=MULTIPLICITY-CONFIG-CLASSES
origin	String	0..1	attr	This attribute specifies whether this configuration container is an AUTOSAR standardized container or whether it is vendor-specific.
postBuildVariantMultiplicity	Boolean	0..1	attr	Indicates if a container may have different number of instances in different post-build variants (previously known as post-build selectable configuration sets). TRUE means yes, FALSE means no.
requiresIndex	Boolean	0..1	attr	Used to define whether the value element for this definition shall be provided with an index.

Table B.59: EcucContainerDef

Class	EcucContainerValue			
Package	M2::AUTOSARTemplates::ECUCDescriptionTemplate			
Note	Represents a Container definition in the ECU Configuration Description.			
Base	<i>ARObject</i> , <i>EcucIndexableValue</i> , <i>Identifiable</i> , <i>MultilanguageReferrable</i> , <i>Referrable</i>			
Aggregated by	EcucContainerValue.subContainer , EcucModuleConfigurationValues.container			
Attribute	Type	Mult.	Kind	Note
definition	EcucContainerDef	0..1	ref	Reference to the definition of this Container in the ECU Configuration Parameter Definition. Tags: xml.sequenceOffset=-10
parameterValue	EcucParameterValue	*	aggr	Aggregates all ECU Configuration Values within this Container. atpVariation: [RS_ECUC_00079] Stereotypes: atpSplittable; atpVariation Tags: atp.Splitkey=parameterValue, parameterValue.variationPoint.shortLabel vh.latestBindingTime=postBuild
referenceValue	EcucAbstractReferenceValue	*	aggr	Aggregates all References with this container. atpVariation: [RS_ECUC_00079] Stereotypes: atpSplittable; atpVariation Tags: atp.Splitkey=referenceValue, referenceValue.variationPoint.shortLabel vh.latestBindingTime=postBuild
subContainer	EcucContainerValue	*	aggr	Aggregates all sub-containers within this container. atpVariation: [RS_ECUC_00078] Stereotypes: atpSplittable; atpVariation Tags: atp.Splitkey=subContainer.shortName, subContainer.variationPoint.shortLabel vh.latestBindingTime=postBuild

Table B.60: EcucContainerValue

Class	EcucEnumerationParamDef			
Package	M2::AUTOSARTemplates::ECUCParameterDefTemplate			
Note	Configuration parameter type for Enumeration.			
Base	<i>ARObject</i> , <i>AtpDefinition</i> , <i>EcucCommonAttributes</i> , <i>EcucDefinitionElement</i> , <i>EcucParameterDef</i> , <i>Identifiable</i> , <i>MultilanguageReferrable</i> , <i>Referrable</i>			
Aggregated by	EcucDestinationUriPolicy.parameter , EcucParamConfContainerDef.parameter			
Attribute	Type	Mult.	Kind	Note
defaultValue	Identifier	0..1	attr	Default value of the enumeration configuration parameter. This string needs to be one of the literals specified for this enumeration.
literal	EcucEnumerationLiteralDef	*	aggr	Aggregation on the literals used to define this enumeration parameter. This aggregation is optional if the surrounding EcucModuleDef has the category STANDARDIZED_MODULE_DEFINITION. If the category attribute of the EcucModuleDef is set to VENDOR_SPECIFIC_MODULE_DEFINITION then this aggregation is mandatory. Stereotypes: atpSplittable Tags: atp.Splitkey=literal.shortName

Table B.61: EcucEnumerationParamDef

Class	EcucForeignReferenceDef			
Package	M2::AUTOSARTemplates::ECUCParameterDefTemplate			
Note	Specify a reference to an XML description of an entity described in another AUTOSAR template.			
Base	<i>ARObject, AtpDefinition, EcucAbstractExternalReferenceDef, EcucAbstractReferenceDef, EcucCommonAttributes, EcucDefinitionElement, Identifiable, MultilanguageReferrable, Referrable</i>			
Aggregated by	EcucDestinationUriPolicy.reference, EcucParamConfContainerDef.reference			
Attribute	Type	Mult.	Kind	Note
destinationType	String	0..1	attr	The type in the AUTOSAR Metamodel to which instance this reference is allowed to point to.

Table B.62: EcucForeignReferenceDef

Class	EcucModuleConfigurationValues			
Package	M2::AUTOSARTemplates::ECUCDescriptionTemplate			
Note	<p>Head of the configuration of one Module. A Module can be a BSW module as well as the RTE and ECU Infrastructure.</p> <p>As part of the BSW module description, the EcucModuleConfigurationValues element has two different roles:</p> <p>The recommendedConfiguration contains parameter values recommended by the BSW module vendor.</p> <p>The preconfiguredConfiguration contains values for those parameters which are fixed by the implementation and cannot be changed.</p> <p>These two EcucModuleConfigurationValues are used when the base EcucModuleConfigurationValues (as part of the base ECU configuration) is created to fill parameters with initial values.</p> <p>Tags:atp.recommendedPackage=EcucModuleConfigurationValues</p>			
Base	<i>ARElement, ARObject, CollectableElement, Identifiable, MultilanguageReferrable, PackageableElement, Referrable</i>			
Aggregated by	ARPackage.element			
Attribute	Type	Mult.	Kind	Note
container	EcucContainerValue	*	aggr	<p>Aggregates all containers that belong to this module configuration.</p> <p>atpVariation: [RS_ECUC_00078]</p> <p>Stereotypes: atpSplittable; atpVariation</p> <p>Tags: atp.Splitkey=container.shortName, container.variationPoint.shortLabel vh.latestBindingTime=postBuild xml.sequenceOffset=10</p>
definition	EcucModuleDef	0..1	ref	<p>Reference to the definition of this EcucModule ConfigurationValues element. Typically, this is a vendor specific module configuration.</p> <p>Tags:xml.sequenceOffset=-10</p>
ecucDefEdition	RevisionLabelString	0..1	attr	<p>This is the version info of the ModuleDef ECUC Parameter definition to which this values conform to / are based on.</p> <p>For the Definition of ModuleDef ECUC Parameters the AdminData shall be used to express the semantic changes. The compatibility rules between the definition and value revision labels is up to the module's vendor.</p>





Class		EcucModuleConfigurationValues		
implementation ConfigVariant	EcucConfiguration VariantEnum	0..1	attr	Specifies the kind of deliverable this EcucModule ConfigurationValues element provides. If this element is not used in a particular role (e.g. preconfigured Configuration or recommendedConfiguration) then the value shall be one of VariantPreCompile, VariantLink Time, VariantPostBuild.
module Description	BswImplementation	0..1	ref	Referencing the BSW module description, which this EcucModuleConfigurationValues element is configuring. This is optional because the EcucModuleConfiguration Values element is also used to configure the ECU infrastructure (memory map) or Application SW-Cs. However in case the EcucModuleConfigurationValues are used to configure the module, the reference is mandatory in order to fetch module specific "common" published information.
postBuildVariant Used	Boolean	0..1	attr	Indicates whether a module implementation has or plans to have (i.e., introduced at link or post-build time) new post-build variation points. TRUE means yes, FALSE means no. If the attribute is not defined, FALSE semantics shall be assumed.

Table B.63: EcucModuleConfigurationValues

Class		EcucModuleDef		
Package		M2::AUTOSARTemplates::ECUCParameterDefTemplate		
Note		Used as the top-level element for configuration definition for Software Modules, including BSW and RTE as well as ECU Infrastructure. Tags: atp.recommendedPackage=EcucModuleDefs		
Base		ARElement, ARObject, AtpBlueprint, AtpBlueprintable, AtpDefinition, CollectableElement, Ecuc DefinitionElement, Identifiable, MultilanguageReferrable, PackageableElement, Referrable		
Aggregated by		ARPackage.element		
Attribute	Type	Mult.	Kind	Note
apiServicePrefix	CIdentifier	0..1	attr	For modules where several instances of the VSMD can be defined the apiServicePrefix defines the API namespace of the derived instances, e.g. Cdd, Xfrm (ComXf, SomelpXf, E2EXf).
container	EcucContainerDef	*	aggr	Aggregates the top-level container definitions of this specific module definition. Stereotypes: atpSplitable Tags: atp.Splitkey=container.shortName xml.sequenceOffset=11
postBuildVariant Support	Boolean	0..1	attr	Indicates if a module supports different post-build variants (previously known as post-build selectable configuration sets). TRUE means yes, FALSE means no.
refinedModule Def	EcucModuleDef	0..1	ref	Optional reference from the Vendor Specific Module Definition to the Standardized Module Definition it refines. In case this EcucModuleDef has the category STANDARDIZED_MODULE_DEFINITION this reference shall not be provided. In case this EcucModuleDef has the category VENDOR_SPECIFIC_MODULE_DEFINITION this reference is mandatory. Stereotypes: atpUriDef





Class	EcucModuleDef			
supported ConfigVariant	EcucConfiguration VariantEnum	*	attr	Specifies which ConfigurationVariants are supported by this software module. This attribute is optional if the Ecuc ModuleDef has the category STANDARDIZED_MODULE_DEFINITION. If the category attribute of the EcucModuleDef is set to VENDOR_SPECIFIC_MODULE_DEFINITION then this attribute is mandatory.

Table B.64: EcucModuleDef

Class	EcucParamConfContainerDef			
Package	M2::AUTOSARTemplates::ECUCParameterDefTemplate			
Note	Used to define configuration containers that can hierarchically contain other containers and/or parameter definitions.			
Base	ARObject, AtpDefinition, EcucContainerDef, EcucDefinitionElement, Identifiable, Multilanguage Referrable, Referrable			
Aggregated by	EcucChoiceContainerDef.choice, EcucDestinationUriPolicy.container, EcucModuleDef.container, EcucParamConfContainerDef.subContainer			
Attribute	Type	Mult.	Kind	Note
parameter	EcucParameterDef	*	aggr	The parameters defined within the EcucParamConf ContainerDef. Stereotypes: atpSplitable Tags: atp.Splitkey=parameter.shortName
reference	EcucAbstractReference Def	*	aggr	The references defined within the EcucParamConf ContainerDef. Stereotypes: atpSplitable Tags: atp.Splitkey=reference.shortName
subContainer	EcucContainerDef	*	aggr	The containers defined within the EcucParamConf ContainerDef. Stereotypes: atpSplitable Tags: atp.Splitkey=subContainer.shortName

Table B.65: EcucParamConfContainerDef

Class	ExecutableEntity (abstract)			
Package	M2::AUTOSARTemplates::CommonStructure::InternalBehavior			
Note	Abstraction of executable code.			
Base	ARObject, Identifiable, MultilanguageReferrable, Referrable			
Subclasses	BswModuleEntity, RunnableEntity			
Attribute	Type	Mult.	Kind	Note
activation Reason	ExecutableEntity ActivationReason	*	aggr	If the ExecutableEntity provides at least one activation Reason element the RTE resp. BSW Scheduler shall provide means to read the activation vector of this executable entity execution. If no activationReason element is provided the feature of being able to determine the activating RTEEvent is disabled for this ExecutableEntity.





Class	ExecutableEntity (abstract)			
canEnter	ExclusiveArea	*	ref	This means that the executable entity can enter/leave the referenced exclusive area through explicit API calls. Stereotypes: atpSplitable; atpVariation Tags: atp.Splitkey=canEnter.exclusiveArea, canEnter.variationPoint.shortLabel vh.latestBindingTime=preCompileTime
exclusiveAreaNestingOrder	ExclusiveAreaNestingOrder	*	ref	This represents the set of ExclusiveAreaNestingOrders recognized by this ExecutableEntity.
minimumStartInterval	TimeValue	0..1	attr	Specifies the time in seconds by which two consecutive starts of an ExecutableEntity are guaranteed to be separated.
reentrancyLevel	ReentrancyLevelEnum	0..1	attr	The reentrancy level of this ExecutableEntity. See the documentation of the enumeration type ReentrancyLevelEnum for details. Please note that nonReentrant interfaces can have also reentrant or multicoreReentrant implementations, and reentrant interfaces can also have multicoreReentrant implementations.
runsInside	ExclusiveArea	*	ref	The executable entity runs completely inside the referenced exclusive area. Stereotypes: atpSplitable; atpVariation Tags: atp.Splitkey=runsInside.exclusiveArea, runsInside.variationPoint.shortLabel vh.latestBindingTime=preCompileTime
swAddrMethod	SwAddrMethod	0..1	ref	Addressing method related to this code entity. Via an association to the same SwAddrMethod, it can be specified that several code entities (even of different modules or components) shall be located in the same memory without already specifying the memory section itself.

Table B.66: ExecutableEntity

Class	ExternalTriggerOccurredEvent			
Package	M2::AUTOSARTemplates::SWComponentTemplate::SwcInternalBehavior::RTEEvents			
Note	This event is raised when the referenced Trigger has occurred.			
Base	ARObject, AbstractEvent, AtpClassifier, AtpFeature, AtpStructureElement, Identifiable , MultilanguageReferrable , RTEEvent , Referrable			
Aggregated by	AtpClassifier.atpFeature, SwcInternalBehavior.event			
Attribute	Type	Mult.	Kind	Note
trigger	Trigger	0..1	iref	The referenced Trigger raises this ExternalTriggerOccurredEvent. InstanceRef implemented by: RTriggerInAtomicSwcInstanceRef

Table B.67: ExternalTriggerOccurredEvent

Class	ExternalTriggeringPoint			
Package	M2::AUTOSARTemplates::SWComponentTemplate::SwcInternalBehavior::Trigger			
Note	If a RunnableEntity owns an ExternalTriggeringPoint it is entitled to raise an ExternalTriggerOccurredEvent.			





Class	ExternalTriggeringPoint			
Base	ARObject			
Aggregated by	RunnableEntity.externalTriggeringPoint			
Attribute	Type	Mult.	Kind	Note
ident	ExternalTriggeringPoint Ident	0..1	aggr	<p>The aggregation in the role ident provides the ability to make the ExternalTriggeringPoint identifiable.</p> <p>From the semantical point of view, the ExternalTriggering Point is considered a first-class Identifiable and therefore the aggregation in the role ident shall always exist (until it may be possible to let ModeAccessPoint directly inherit from Identifiable).</p> <p>Stereotypes: atpIdentityContributor Tags:xml.sequenceOffset=-100</p>
trigger	Trigger	0..1	iref	<p>The trigger taken for the ExternalTriggeringPoint.</p> <p>Tags: xml.namePlural=TRIGGER-IREF xml.roleElement=false xml.roleWrapperElement=true xml.typeElement=true xml.typeWrapperElement=false InstanceRef implemented by:PTriggerInAtomicSwcType InstanceRef</p>

Table B.68: ExternalTriggeringPoint

Class	FlatInstanceDescriptor			
Package	M2::AUTOSARTemplates::CommonStructure::FlatMap			
Note	<p>Represents exactly one node (e.g. a component instance or data element) of the instance tree of a software system. The purpose of this element is to map the various nested representations of this instance to a flat representation and assign a unique name (shortName) to it.</p> <p>Use cases:</p> <ul style="list-style-type: none"> • Specify unique names of measurable data to be used by MCD tools • Specify unique names of calibration data to be used by MCD tool • Specify a unique name for an instance of a component prototype in the ECU extract of the system description <p>Note that in addition it is possible to assign alias names via AliasNameAssignment.</p>			
Base	ARObject, Identifiable, MultilanguageReferrable, Referrable			
Aggregated by	FlatMap.instance			
Attribute	Type	Mult.	Kind	Note
ecuExtract Reference	AtpFeature	0..1	iref	<p>Refers to the instance in the ECU extract. This is valid only, if the FlatMap is used in the context of an ECU extract.</p> <p>The reference shall be such that it uniquely defines the object instance. For example, if a data prototype is declared as a role within an SwcInternalBehavior, it is not enough to state the SwcInternalBehavior as context and the aggregated data prototype as target. In addition, the reference shall also include the complete path identifying instance of the component prototype and the Atomic SoftwareComponentType, which is referred by the particular SwcInternalBehavior.</p> <p>Tags:xml.sequenceOffset=40 InstanceRef implemented by:AnyInstanceRef</p>





Class		FlatInstanceDescriptor		
role	Identifier	0..1	attr	The role denotes the particular role of the downstream memory location described by this FlatInstanceDescriptor. It applies to use case where one upstream object results in multiple downstream objects, e.g. ModeDeclaration GroupPrototypes which are measurable. In this case the RTE will provide locations for current mode, previous mode and next mode.
rtePluginProps	RtePluginProps	0..1	aggr	The properties of a communication graph with respect to the utilization of RTE Implementation Plug-in. Stereotypes: atpSplitable Tags: atp.Splitkey=rtePluginProps
swDataDef Props	SwDataDefProps	0..1	aggr	The properties of this FlatInstanceDescriptor. Stereotypes: atpSplitable Tags: atp.Splitkey=swDataDefProps
upstream Reference	AtpFeature	0..1	iref	Refers to the instance in the context of an "upstream" descriptions, wich could be the system or system extract description, the basic software module description or (if a flat map is used in preliminary context) a description of an atomic component or composition. This reference is optional in case the flat map is used in ECU context. The reference shall be such that it uniquely defines the object instance in the given context. For example, if a data prototype is declared as a role within an SwcInternal Behavior, it is not enough to state the SwcInternal Behavior as context and the aggregated data prototype as target. In addition, the reference shall also include the complete path identifying the instance of the component prototype that contains the particular instance of Swc InternalBehavior. Tags: xml.sequenceOffset=20 InstanceRef implemented by: AnyInstanceRef

Table B.69: FlatInstanceDescriptor

Class		FunctionInhibitionAvailabilityNeeds		
Package	M2::AUTOSARTemplates::CommonStructure::ServiceNeeds			
Note	Specifies the abstract needs on the configuration of the Function Inhibition Manager to provide the control function for one Function Identifier (FID).			
Base	<i>AObject</i> , <i>Identifiable</i> , <i>MultilanguageReferrable</i> , <i>Referrable</i> , <i>ServiceNeeds</i>			
Aggregated by	BswServiceDependency.serviceNeeds, SwcServiceDependency.serviceNeeds			
Attribute	Type	Mult.	Kind	Note
controlledFid	FunctionInhibitionNeeds	0..1	ref	This reference represents the controlled FID

Table B.70: FunctionInhibitionAvailabilityNeeds

Class		FunctionInhibitionNeeds		
Package	M2::AUTOSARTemplates::CommonStructure::ServiceNeeds			
Note	Specifies the abstract needs on the configuration of the Function Inhibition Manager for one Function Identifier (FID). This class currently contains no attributes. Its name can be regarded as a symbol identifying the FID from the viewpoint of the component or module which owns this class.			
Base	<i>AObject</i> , <i>Identifiable</i> , <i>MultilanguageReferrable</i> , <i>Referrable</i> , <i>ServiceNeeds</i>			
Aggregated by	BswServiceDependency.serviceNeeds, SwcServiceDependency.serviceNeeds			





Class	FunctionInhibitionNeeds			
Attribute	Type	Mult.	Kind	Note
-	-	-	-	-

Table B.71: FunctionInhibitionNeeds

Enumeration	HandleInvalidEnum
Package	M2::AUTOSARTemplates::SWComponentTemplate::Communication
Note	Strategies of handling the reception of invalidValue.
Aggregated by	InvalidationPolicy.handleInvalid , ISignalPort.handleInvalid
Literal	Description
dontInvalidate	Invalidation is switched off. Tags: atp.EnumerationLiteralIndex=0
external Replacement	Replace a received invalidValue. The replacement value is sourced from the aggregation in the role replaceWith. Tags: atp.EnumerationLiteralIndex=1
keep	The application software is supposed to handle signal invalidation on RTE API level either by Data ReceiveErrorEvent or check of error code on read access. Tags: atp.EnumerationLiteralIndex=2
replace	Replace a received invalidValue. The replacement value is specified by the initValue. Tags: atp.EnumerationLiteralIndex=3

Table B.72: HandleInvalidEnum

Class	Identifiable (abstract)
Package	M2::AUTOSARTemplates::GenericStructure::GeneralTemplateClasses::Identifiable
Note	Instances of this class can be referred to by their identifier (within the namespace borders). In addition to this, Identifiables are objects which contribute significantly to the overall structure of an AUTOSAR description. In particular, Identifiables might contain Identifiables.
Base	ARObject , MultilanguageReferrable , Referrable
Subclasses	ARPackage , AbstractDolpLogicAddressProps , AbstractEvent , AbstractImplementationDataTypeElement , AbstractSecurityEventFilter , AbstractSecurityIdsmInstanceFilter , AbstractServiceInstance , AppOsTaskProxyToEcuTaskProxyMapping , ApplicationEndpoint , ApplicationError , ApplicationPartitionToEcuPartitionMapping , AsynchronousServerCallResultPoint , AtpBlueprint , AtpBlueprintable , AtpClassifier , AtpFeature , AutosarOperationArgumentInstance , AutosarVariableInstance , BinaryManifestAddressableObject , BinaryManifestItemDefinition , BinaryManifestResource , BinaryManifestResourceDefinition , BlockState , BswInternalTriggeringPoint , BswModuleDependency , BuildActionEntity , BuildActionEnvironment , CanTpAddress , CanTpChannel , CanTpNode , Chapter , ClassContentConditional , ClientIdDefinition , ClientServerOperation , Code , CollectableElement , ComManagementMapping , CommConnectorPort , CommunicationConnector , CommunicationController , Compiler , ConsistencyNeeds , ConsumedEventGroup , CouplingPort , CouplingPortStructuralElement , CpSoftwareClusterResource , CpSoftwareClusterResourceToApplicationPartitionMapping , CpSoftwareClusterToEcuInstanceMapping , CpSoftwareClusterToResourceMapping , CryptoServiceMapping , DataPrototypeGroup , DataTransformation , DependencyOnArtifact , DiagEventDebounceAlgorithm , DiagnosticConnectedIndicator , DiagnosticDataElement , DiagnosticDebounceAlgorithmProps , DiagnosticFunctionInhibitSource , DiagnosticParameterElement , DiagnosticRoutineSubfunction , DltApplication , DltArgument , DltLogChannel , DltMessage , DolpInterface , DolpLogicAddress , DolpRoutingActivation , ECUMapping , EOCExecutableEntityRefAbstract , EcuPartition , EcucContainerValue , EcucDefinitionElement , EcucDestinationUriDef , EcucEnumerationLiteralDef , EcucQuery , EcucValidationCondition , EndToEndProtection , EthernetWakeupSleepOnDataLineConfig , EventHandler , ExclusiveArea , ExecutableEntity , ExecutionTime , FMAttributeDef , FMFeatureMapAssertion , FMFeatureMapCondition , FMFeatureMapElement , FMFeatureRelation , FMFeatureRestriction , FMFeatureSelection , FlatInstanceDescriptor , FlexrayArTpNode , FlexrayTpConnectionControl , FlexrayTpNode , FlexrayTpPduPool , FrameTriggering , GeneralParameter , GlobalTimeGateway , GlobalTimeMaster ,





Class	Identifiable (abstract)			
	<p style="text-align: center;">△</p> <p><i>GlobalTimeSlave, HeapUsage, HwAttributeDef, HwAttributeLiteralDef, HwPin, HwPinGroup, IPSecRule, IPv6ExtHeaderFilterList, ISignalToIPduMapping, ISignalTriggering, IdentCaption, InternalTriggeringPoint, J1939SharedAddressCluster, J1939TpNode, Keyword, LifeCycleState, LinScheduleTable, LinTpNode, Linker, MacMulticastGroup, MacSecKayParticipant, McDataInstance, MemorySection, ModeDeclaration, ModeDeclarationMapping, ModeSwitchPoint, NetworkEndpoint, NmCluster, NmEcu, NmNode, NvBlockDescriptor, PackageableElement, ParameterAccess, PduActivationRoutingGroup, PduToFrameMapping, PduTriggering, PerInstanceMemory, PhysicalChannel, PortElementToCommunicationResourceMapping, PortGroup, PortInterfaceMapping, PossibleErrorReaction, ResourceConsumption, RootSwCompositionPrototype, RptComponent, RptContainer, RptExecutableEntity, RptExecutableEntityEvent, RptExecutionContext, RptProfile, RptServicePoint, RteEventInCompositionSeparation, RteEventInCompositionToOsTaskProxyMapping, RteEventInSystemSeparation, RteEventInSystemToOsTaskProxyMapping, RunnableEntityGroup, SdgAttribute, SdgClass, SecureCommunicationAuthenticationProps, SecureCommunicationFreshnessProps, SecurityEventContextProps, ServerCallPoint, ServiceNeeds, SignalServiceTranslationElementProps, SignalServiceTranslationEventProps, SignalServiceTranslationProps, SocketAddress, SomeipTpChannel, SpecElementReference, StackUsage, StaticSocketConnection, StructuredReq, SwGenericAxisParamType, SwServiceArg, SwcServiceDependency, SwcToApplicationPartitionMapping, SwcToEcuMapping, SwcToImplMapping, SystemMapping, TDCpSoftwareClusterMapping, TDCpSoftwareClusterResourceMapping, TcpOptionFilterList, TimingClock, TimingClockSyncAccuracy, TimingCondition, TimingConstraint, TimingDescription, TimingExtensionResource, TimingModelInstance, TlsCryptoCipherSuite, TlsCryptoCipherSuiteProps, Topic1, TpAddress, TraceableTable, TraceableText, TracedFailure, TransformationProps, TransformationTechnology, Trigger, VariableAccess, VariationPointProxy, ViewMap, VlanConfig, WaitPoint</i></p>			
Attribute	Type	Mult.	Kind	Note
adminData	AdminData	0..1	aggr	<p>This represents the administrative data for the identifiable object.</p> <p>Stereotypes: atpSplittable Tags: atp.Splitkey=adminData xml.sequenceOffset=-40</p>
annotation	Annotation	*	aggr	<p>Possibility to provide additional notes while defining a model element (e.g. the ECU Configuration Parameter Values). These are not intended as documentation but are mere design notes.</p> <p>Tags:xml.sequenceOffset=-25</p>
category	CategoryString	0..1	attr	<p>The category is a keyword that specializes the semantics of the Identifiable. It affects the expected existence of attributes and the applicability of constraints.</p> <p>Tags:xml.sequenceOffset=-50</p>
desc	MultiLanguageOverviewParagraph	0..1	aggr	<p>This represents a general but brief (one paragraph) description what the object in question is about. It is only one paragraph! Desc is intended to be collected into overview tables. This property helps a human reader to identify the object in question.</p> <p>More elaborate documentation, (in particular how the object is built or used) should go to "introduction".</p> <p>Tags:xml.sequenceOffset=-60</p>
introduction	DocumentationBlock	0..1	aggr	<p>This represents more information about how the object in question is built or is used. Therefore it is a DocumentationBlock.</p> <p>Tags:xml.sequenceOffset=-30</p>





Class	Identifiable (abstract)			
uuid	String	0..1	attr	<p>The purpose of this attribute is to provide a globally unique identifier for an instance of a meta-class. The values of this attribute should be globally unique strings prefixed by the type of identifier. For example, to include a DCE UUID as defined by The Open Group, the UUID would be preceded by "DCE:". The values of this attribute may be used to support merging of different AUTOSAR models. The form of the UUID (Universally Unique Identifier) is taken from a standard defined by the Open Group (was Open Software Foundation). This standard is widely used, including by Microsoft for COM (GUIDs) and by many companies for DCE, which is based on CORBA. The method for generating these 128-bit IDs is published in the standard and the effectiveness and uniqueness of the IDs is not in practice disputed. If the id namespace is omitted, DCE is assumed. An example is "DCE:2fac1234-31f8-11b4-a222-08002b34c003". The uuid attribute has no semantic meaning for an AUTOSAR model and there is no requirement for AUTOSAR tools to manage the timestamp.</p> <p>Tags:xml.attribute=true</p>

Table B.73: Identifiable

Class	ImplementationDataType			
Package	M2::AUTOSARTemplates::CommonStructure::ImplementationDataTypes			
Note	<p>Describes a reusable data type on the implementation level. This will typically correspond to a typedef in C-code.</p> <p>Tags:atp.recommendedPackage=ImplementationDataTypes</p>			
Base	<p><i>ARElement, ARObject, AbstractImplementationDataType, AtpBlueprint, AtpBlueprintable, AtpClassifier, AtpType, AutosarDataType, CollectableElement, Identifiable, MultilanguageReferrable, PackageableElement, Referrable</i></p>			
Aggregated by	ARPackage.element			
Attribute	Type	Mult.	Kind	Note
dynamicArraySizeProfile	String	0..1	attr	Specifies the profile which the array will follow in case this data type is a variable size array.
isStructWithOptionalElement	Boolean	0..1	attr	<p>This attribute is only valid if the attribute category is set to STRUCTURE.</p> <p>If set to true, this attribute indicates that the ImplementationDataType has been created with the intention to define at least one element of the structure as optional.</p>
subElement (ordered)	ImplementationDataTypeElement	*	aggr	<p>Specifies an element of an array, struct, or union data type.</p> <p>The aggregation of ImplementationDataTypeElement is subject to variability with the purpose to support the conditional existence of elements inside a ImplementationDataType representing a structure.</p> <p>Stereotypes: atpSplitable; atpVariation</p> <p>Tags: atp.Splitkey=subElement.shortName, subElement.variationPoint.shortLabel vh.latestBindingTime=preCompileTime</p>





Class	ImplementationDataType			
symbolProps	SymbolProps	0..1	aggr	This represents the SymbolProps for the ImplementationDataType. Stereotypes: atpSplitable Tags: atp.Splitkey=symbolProps.shortName
typeEmitter	NameToken	0..1	attr	This attribute is used to control which part of the AUTOSAR toolchain is supposed to trigger data type definitions.

Table B.74: ImplementationDataType

Class	ImplementationDataTypeElement			
Package	M2::AUTOSARTemplates::CommonStructure::ImplementationDataTypes			
Note	<p>Declares a data object which is locally aggregated. Such an element can only be used within the scope where it is aggregated.</p> <p>This element either consists of further subElements or it is further defined via its swDataDefProps.</p> <p>There are several use cases within the system of ImplementationDataTypes for such a local declaration:</p> <ul style="list-style-type: none"> • It can represent the elements of an array, defining the element type and array size • It can represent an element of a struct, defining its type • It can be the local declaration of a debug element. 			
Base	ARObject , AbstractImplementationDataTypeElement , AtpClassifier , AtpFeature , AtpStructureElement , Identifiable , MultilanguageReferrable , Referrable			
Aggregated by	AtpClassifier.atpFeature , ImplementationDataType.subElement , ImplementationDataTypeElement.subElement			
Attribute	Type	Mult.	Kind	Note
arrayImplPolicy	ArrayImplPolicyEnum	0..1	attr	This attribute controls the implementation of the payload of an array. It shall only be used if the enclosing ImplementationDataType constitutes an array.
arraySize	PositiveInteger	0..1	attr	The existence of this attributes (if bigger than 0) defines the size of an array and declares that this ImplementationDataTypeElement represents the type of each single array element. Stereotypes: atpVariation Tags: vh.latestBindingTime=preCompileTime
arraySizeHandling	ArraySizeHandlingEnum	0..1	attr	The way how the size of the array is handled in case of a variable size array.
arraySizeSemantics	ArraySizeSemanticsEnum	0..1	attr	This attribute controls the meaning of the value of the array size.
isOptional	Boolean	0..1	attr	<p>This attribute represents the ability to declare the enclosing ImplementationDataTypeElement as optional. This means that, at runtime, the ImplementationDataTypeElement may or may not have a valid value and shall therefore be ignored.</p> <p>The underlying runtime software provides means to set the CppImplementationDataTypeElement as not valid at the sending end of a communication and determine its validity at the receiving end.</p>





Class	ImplementationDataTypeElement			
subElement (ordered)	ImplementationDataTypeElement	*	aggr	<p>Element of an array, struct, or union in case of a nested declaration (i.e. without using "typedefs").</p> <p>The aggregation of ImplementationDataTypeElement is subject to variability with the purpose to support the conditional existence of elements inside a ImplementationDataType representing a structure.</p> <p>Stereotypes: atpSplitable; atpVariation Tags: atp.Splitkey=subElement.shortName, subElement.variationPoint.shortLabel vh.latestBindingTime=preCompileTime</p>
swDataDef Props	SwDataDefProps	0..1	aggr	<p>The properties of this ImplementationDataTypeElement.</p> <p>Stereotypes: atpSplitable Tags:atp.Splitkey=swDataDefProps</p>

Table B.75: ImplementationDataTypeElement

Class	InitEvent			
Package	M2::AUTOSARTemplates::SWComponentTemplate::SwcInternalBehavior::RTEEvents			
Note	This RTEEvent is supposed to be used for initialization purposes, i.e. for starting and restarting a partition. It is not guaranteed that all RunnableEntities referenced by this InitEvent are executed before the 'regular' RunnableEntities are executed for the first time. The execution order depends on the task mapping.			
Base	ARObject, AbstractEvent, AtpClassifier, AtpFeature, AtpStructureElement, Identifiable , MultilanguageReferrable, RTEEvent , Referrable			
Aggregated by	AtpClassifier.atpFeature, SwcInternalBehavior.event			
Attribute	Type	Mult.	Kind	Note
-	-	-	-	-

Table B.76: InitEvent

Class	<i>InternalBehavior</i> (abstract)			
Package	M2::AUTOSARTemplates::CommonStructure::InternalBehavior			
Note	Common base class (abstract) for the internal behavior of both software components and basic software modules/clusters.			
Base	ARObject, AtpClassifier, AtpFeature, AtpStructureElement, Identifiable , MultilanguageReferrable, Referrable			
Subclasses	BswInternalBehavior, SwcInternalBehavior			
Aggregated by	AtpClassifier.atpFeature			
Attribute	Type	Mult.	Kind	Note
-	-	-	-	-





Class	InternalBehavior (abstract)			
constantMemory	ParameterDataPrototype	*	aggr	<p>Describes a read only memory object containing characteristic value(s) implemented by this InternalBehavior.</p> <p>The shortName of ParameterDataPrototype has to be equal to the 'C' identifier of the described constant.</p> <p>The characteristic value(s) might be shared between SwComponentPrototypes of the same SwComponentType.</p> <p>The aggregation of constantMemory is subject to variability with the purpose to support variability in the software component or module implementations. Typically different algorithms in the implementation are requiring different number of memory objects.</p> <p>Stereotypes: atpSplittable; atpVariation Tags: atp.Splitkey=constantMemory.shortName, constantMemory.variationPoint.shortLabel vh.latestBindingTime=preCompileTime</p>
constantValueMapping	ConstantSpecificationMappingSet	*	ref	<p>Reference to the ConstantSpecificationMapping to be applied for the particular InternalBehavior</p> <p>Stereotypes: atpSplittable Tags:atp.Splitkey=constantValueMapping</p>
dataTypeMapping	DataTypeMappingSet	*	ref	<p>Reference to the DataTypeMapping to be applied for the particular InternalBehavior</p> <p>Stereotypes: atpSplittable Tags:atp.Splitkey=dataTypeMapping</p>
exclusiveArea	ExclusiveArea	*	aggr	<p>This specifies an ExclusiveArea for this InternalBehavior. The exclusiveArea is local to the component resp. module. The aggregation of ExclusiveAreas is subject to variability. Note: the number of ExclusiveAreas might vary due to the conditional existence of RunnableEntities or BswModuleEntities.</p> <p>Stereotypes: atpSplittable; atpVariation Tags: atp.Splitkey=exclusiveArea.shortName, exclusiveArea.variationPoint.shortLabel vh.latestBindingTime=preCompileTime</p>
exclusiveAreaNestingOrder	ExclusiveAreaNestingOrder	*	aggr	<p>This represents the set of ExclusiveAreaNestingOrder owned by the InternalBehavior.</p> <p>Stereotypes: atpSplittable; atpVariation Tags: atp.Splitkey=exclusiveAreaNestingOrder.shortName, exclusiveAreaNestingOrder.variationPoint.shortLabel vh.latestBindingTime=preCompileTime</p>





Class	InternalBehavior (abstract)			
staticMemory	VariableDataPrototype	*	aggr	<p>Describes a read and writeable static memory object representing measurement variables implemented by this software component. The term "static" is used in the meaning of "non-temporary" and does not necessarily specify a linker encapsulation. This kind of memory is only supported if supportsMultipleInstantiation is FALSE.</p> <p>The shortName of the VariableDataPrototype has to be equal with the "C" identifier of the described variable.</p> <p>The aggregation of staticMemory is subject to variability with the purpose to support variability in the software component's implementations.</p> <p>Typically different algorithms in the implementation are requiring different number of memory objects.</p> <p>Stereotypes: atpSplittable; atpVariation Tags: atp.Splitkey=staticMemory.shortName, staticMemory.variationPoint.shortLabel vh.latestBindingTime=preCompileTime</p>

Table B.77: InternalBehavior

Class	InternalConstrs			
Package	M2::MSR::AsamHdo::Constraints::GlobalConstraints			
Note	This meta-class represents the ability to express internal constraints.			
Base	<i>ARObject</i>			
Aggregated by	DataConstrRule.internalConstrs			
Attribute	Type	Mult.	Kind	Note
lowerLimit	Limit	0..1	attr	<p>This specifies the lower limit of the constraint.</p> <p>Stereotypes: atpVariation Tags: vh.latestBindingTime=preCompileTime xml.sequenceOffset=20</p>
maxDiff	Numerical	0..1	attr	<p>Maximum difference that is permitted between two consecutive values if the constraint is applied to an axis.</p> <p>Tags:xml.sequenceOffset=60</p>
maxGradient	Numerical	0..1	attr	<p>This element specifies the maximum slope that may be used in maps and curves.</p> <p>Tags:xml.sequenceOffset=50</p>
monotony	MonotonyEnum	0..1	attr	<p>This element specifies the monotony characteristics of the current internal or physical limits. The following table shows the monotony characteristics which are to be filled through the corresponding values.</p> <p>If the element has no contents or if it is omitted, "no Monotony" is the default content.</p> <p>Tags:xml.sequenceOffset=70</p>





Class	InternalConstrs			
scaleConstr (ordered)	ScaleConstr	*	aggr	This is one particular scale which contributes to the data constraints. Tags: xml.roleElement=true xml.roleWrapperElement=true xml.sequenceOffset=40 xml.typeElement=false xml.typeWrapperElement=false
upperLimit	Limit	0..1	attr	This specifies the upper limit defined by the constraint. Stereotypes: atpVariation Tags: vh.latestBindingTime=preCompileTime xml.sequenceOffset=30

Table B.78: InternalConstrs

Class	InternalTriggerOccurredEvent			
Package	M2::AUTOSARTemplates::SWComponentTemplate::SwcInternalBehavior::RTEEvents			
Note	This event is raised when the referenced InternalTriggeringPoint has occurred.			
Base	ARObject, AbstractEvent, AtpClassifier, AtpFeature, AtpStructureElement, Identifiable , MultilanguageReferrable , RTEEvent , Referrable			
Aggregated by	AtpClassifier.atpFeature, SwcInternalBehavior.event			
Attribute	Type	Mult.	Kind	Note
eventSource	InternalTriggeringPoint	0..1	ref	The referenced InternalTriggeringPoint raises this InternalTriggerOccurredEvent.

Table B.79: InternalTriggerOccurredEvent

Class	InvalidationPolicy			
Package	M2::AUTOSARTemplates::SWComponentTemplate::PortInterface			
Note	Specifies whether the component can actively invalidate a particular dataElement. If no invalidationPolicy points to a dataElement this is considered to yield the identical result as if the handleInvalid attribute was set to dontInvalidate.			
Base	ARObject			
Aggregated by	SenderReceiverInterface.invalidationPolicy			
Attribute	Type	Mult.	Kind	Note
dataElement	VariableDataPrototype	0..1	ref	Reference to the dataElement for which the InvalidationPolicy applies.
handleInvalid	HandleInvalidEnum	0..1	attr	This attribute controls how invalidation is applied to the dataElement.

Table B.80: InvalidationPolicy

Class	McDataInstance			
Package	M2::AUTOSARTemplates::CommonStructure::MeasurementCalibrationSupport			
Note	<p>Describes the specific properties of one data instance in order to support measurement and/or calibration of this data instance.</p> <p>The most important attributes are:</p> <ul style="list-style-type: none"> • Its shortName is copied from the ECU Flat map (if applicable) and will be used as identifier and for display by the MC system. • The category is copied from the corresponding data type (ApplicationDataType if defined, otherwise ImplementationDataType) as far as applicable. • The symbol is the one used in the programming language. It will be used to find out the actual memory address by the final generation tool with the help of linker generated information. <p>It is assumed that in the M1 model this part and all the aggregated and referred elements (with the exception of the Flat Map and the references from ImplementationElementInParameterInstanceRef and McAccessDetails) are completely generated from "upstream" information. This means, that even if an element like e.g. a CompuMethod is only used via reference here, it will be copied into the M1 artifact which holds the complete McSupportData for a given Implementation.</p>			
Base	<i>AObject</i> , <i>Identifiable</i> , <i>MultilanguageReferrable</i> , <i>Referrable</i>			
Aggregated by	McDataInstance.subElement , McSupportData.mcParameterInstance , McSupportData.mcVariableInstance			
Attribute	Type	Mult.	Kind	Note
arraySize	PositiveInteger	0..1	attr	The existence of this attribute turns the data instance into an array of data. The attribute determines the size of the array in terms of number of elements.
displayIdentifier	McIdentifier	0..1	attr	An optional attribute to be used to set the ASAM ASAP2 DISPLAY_IDENTIFIER attribute.
flatMapEntry	FlatInstanceDescriptor	0..1	ref	<p>Reference to the corresponding entry in the ECU Flat Map. This allows to trace back to the original specification of the generated data instance. This link shall be added by the RTE generator mainly for documentation purposes.</p> <p>The reference is optional because</p> <ul style="list-style-type: none"> • The McDataInstance may represent an array or struct in which only the subElements correspond to FlatMap entries. • The McDataInstance may represent a task local buffer for rapid prototyping access which is different from the "main instance" used for measurement access.
instanceInMemory	ImplementationElementInParameterInstanceRef	0..1	aggr	Reference to the corresponding data instance in the description of calibration data structures published by the RTE generator. This is used to support emulation methods inside the ECU, it is not required for A2L generation.
mcDataAccessDetails	McDataAccessDetails	0..1	aggr	Refers to "upstream" information on how the RTE uses this data instance. Use Case: Rapid Prototyping
mcDataAssignment	RoleBasedMcDataAssignment	*	aggr	An assignment between McDataInstances. This supports the indication of related McDataElement implementing the of "RP global buffer", "RP global measurement buffer", "RP enabler flag".
resultingProperties	SwDataDefProps	0..1	aggr	<p>These are the generated properties resulting from decisions taken by the RTE generator for the actually implemented data instance. Only those properties are relevant here, which are needed for the measurement and calibration system.</p> <p>Stereotypes: atpSplitable Tags:atp.Splitkey=resultingProperties</p>





Class	McDataInstance			
resultingRptSw Prototyping Access	RptSwPrototyping Access	0..1	aggr	Describes the implemented accessibility of data and modes by the rapid prototyping tooling.
role	Identifier	0..1	attr	An optional attribute to be used for additional information on the role of this data instance, for example in the context of rapid prototyping.
rptImplPolicy	RptImplPolicy	0..1	aggr	Describes the implemented code preparation for rapid prototyping at data accesses for a hook based bypassing.
subElement (ordered)	McDataInstance	*	aggr	<p>This relation indicates, that the target element is part of a "struct" which is given by the source element. This information will be used by the final generator to set up the correct addressing scheme.</p> <p>Stereotypes: atpSplitable; atpVariation Tags: atp.Splitkey=subElement.shortName, subElement.variationPoint.shortLabel vh.latestBindingTime=preCompileTime</p>
symbol	SymbolString	0..1	attr	<p>This String is used to determine the memory address during final generation of the MC configuration data (e.g. "A2L" file) . It shall be the name of the element in the programming language such that it can be identified in linker generated information.</p> <p>In case the McDataInstance is part of composite data in the programming language, the symbol String may include parts denoting the element context, unless the context is given by the symbol attribute of an enclosing McDataInstance. This means in particular for the C language that the "." character shall be used as a separator between the name of a "struct" variable the name of one of its elements.</p> <p>The symbol can differ from the shortName in case of generated C data declarations.</p> <p>It is an optional attribute since it may be missing in case the instance represents an element (e.g. a single array element) which has no name in the linker map.</p> <p>Stereotypes: atpSplitable Tags:atp.Splitkey=symbol</p>

Table B.81: McDataInstance

Class	McSupportData			
Package	M2::AUTOSARTemplates::CommonStructure::MeasurementCalibrationSupport			
Note	Root element for all measurement and calibration support data related to one Implementation artifact on an ECU. There shall be one such element related to the RTE implementation (if it owns MC data) and a separate one for each module or component, which owns private MC data.			
Base	ARObject			
Aggregated by	Implementation.mcSupport			
Attribute	Type	Mult.	Kind	Note





Class	McSupportData			
emulation Support	McSwEmulationMethod Support	*	aggr	<p>Describes the calibration method used by the RTE. This information is not needed for A2L generation, but to setup software emulation in the ECU.</p> <p>Stereotypes: atpSplitable; atpVariation Tags: atp.Splitkey=emulationSupport, emulationSupport.variationPoint.shortLabel vh.latestBindingTime=preCompileTime</p>
mcParameter Instance	McDataInstance	*	aggr	<p>A data instance to be used for calibration.</p> <p>Stereotypes: atpSplitable; atpVariation Tags: atp.Splitkey=mcParameterInstance.shortName, mcParameterInstance.variationPoint.shortLabel vh.latestBindingTime=postBuild</p>
mcVariable Instance	McDataInstance	*	aggr	<p>A data instance to be used for measurement.</p> <p>Stereotypes: atpSplitable; atpVariation Tags: atp.Splitkey=mcVariableInstance.shortName, mcVariableInstance.variationPoint.shortLabel vh.latestBindingTime=postBuild</p>
measurable System ConstantValues	SwSystemconstant ValueSet	*	ref	<p>Sets of system constant values to be transferred to the MCD system, because the system constants have been specified with "swCalibrationAccess" = readonly.</p>
rptSupportData	RptSupportData	0..1	aggr	<p>The rapid prototyping support data belonging to this implementation. The aggregation is <<atpSplitable>> because in case of an already existing BSW Implementation model, this description will be added later in the process, namely at code generation time.</p> <p>Stereotypes: atpSplitable Tags:atp.Splitkey=rptSupportData</p>

Table B.82: McSupportData

Class	ModeAccessPoint			
Package	M2::AUTOSARTemplates::SWComponentTemplate::SwcInternalBehavior::ModeDeclarationGroup			
Note	A ModeAccessPoint is required by a RunnableEntity owned by a Mode Manager or Mode User. Its semantics implies the ability to access the current mode (provided by the RTE) of a ModeDeclaration GroupPrototype's ModeDeclarationGroup.			
Base	<i>ARObject</i>			
Aggregated by	RunnableEntity.modeAccessPoint			
Attribute	Type	Mult.	Kind	Note
ident	ModeAccessPointIdent	0..1	aggr	<p>The aggregation in the role ident provides the ability to make the ModeAccessPoint identifiable.</p> <p>From the semantical point of view, the ModeAccessPoint is considered a first-class Identifiable and therefore the aggregation in the role ident shall always exist (until it may be possible to let ModeAccessPoint directly inherit from Identifiable).</p> <p>Stereotypes: atpIdentifyContributor Tags:xml.sequenceOffset=-100</p>





Class	ModeAccessPoint			
modeGroup	ModeDeclarationGroup Prototype	0..1	iref	The mode declaration group that is accessed by this runnable. Tags: xml.typeElement=true InstanceRef implemented by: ModeGroupInAtomicSwc InstanceRef

Table B.83: ModeAccessPoint

Class	ModeDeclaration			
Package	M2::AUTOSARTemplates::CommonStructure::ModeDeclaration			
Note	Declaration of one Mode. The name and semantics of a specific mode is not defined in the meta-model.			
Base	<i>ARObject, AtpClassifier, AtpFeature, AtpStructureElement, Identifiable, MultilanguageReferrable, Referrable</i>			
Aggregated by	<i>AtpClassifier.atpFeature, ModeDeclarationGroup.modeDeclaration</i>			
Attribute	Type	Mult.	Kind	Note
value	PositiveInteger	0..1	attr	The RTE shall take the value of this attribute for generating the source code representation of this Mode Declaration.

Table B.84: ModeDeclaration

Class	ModeDeclarationGroup			
Package	M2::AUTOSARTemplates::CommonStructure::ModeDeclaration			
Note	A collection of Mode Declarations. Also, the initial mode is explicitly identified. Tags: atp.recommendedPackage=ModeDeclarationGroups			
Base	<i>ARElement, ARObject, AtpBlueprint, AtpBlueprintable, AtpClassifier, AtpType, CollectableElement, Identifiable, MultilanguageReferrable, PackageableElement, Referrable</i>			
Aggregated by	ARPackage.element			
Attribute	Type	Mult.	Kind	Note
initialMode	ModeDeclaration	0..1	ref	The initial mode of the ModeDeclarationGroup. This mode is active before any mode switches occurred.
mode Declaration	ModeDeclaration	*	aggr	The ModeDeclarations collected in this ModeDeclaration Group. Stereotypes: atpSplitable; atpVariation Tags: atp.Splitkey=modeDeclaration.shortName, mode Declaration.variationPoint.shortLabel vh.latestBindingTime=blueprintDerivationTime
modeManager ErrorBehavior	ModeErrorBehavior	0..1	aggr	This represents the ability to define the error behavior expected by the mode manager in case of errors on the mode user side (e.g. terminated mode user).
modeTransition	ModeTransition	*	aggr	This represents the available ModeTransitions of the ModeDeclarationGroup
modeUserError Behavior	ModeErrorBehavior	0..1	aggr	This represents the definition of the error behavior expected by the mode user in case of errors on the mode manager side (e.g. terminated mode manager).
onTransition Value	PositiveInteger	0..1	attr	The value of this attribute shall be taken into account by the RTE generator for programmatically representing a value used for the transition between two statuses.

Table B.85: ModeDeclarationGroup

Class	ModeDeclarationGroupPrototype			
Package	M2::AUTOSARTemplates::CommonStructure::ModeDeclaration			
Note	The ModeDeclarationGroupPrototype specifies a set of Modes (ModeDeclarationGroup) which is provided or required in the given context.			
Base	ARObject, AtpFeature, AtpPrototype, Identifiable , MultilanguageReferrable , Referrable			
Aggregated by	AtpClassifier.atpFeature, BswModuleDescription.providedModeGroup , BswModuleDescription.requiredModeGroup , FirewallStateSwitchInterface.firewallStateMachine, FunctionGroupSet.functionGroup, ModeSwitchInterface.modeGroup , Process.processStateMachine, StateManagementStateNotification.stateMachine			
Attribute	Type	Mult.	Kind	Note
swCalibrationAccess	SwCalibrationAccessEnum	0..1	attr	This allows for specifying whether or not the enclosing ModeDeclarationGroupPrototype can be measured at run-time.
type	ModeDeclarationGroup	0..1	tref	The "collection of ModeDeclarations" (= ModeDeclarationGroup) supported by a component Stereotypes: isOfType

Table B.86: ModeDeclarationGroupPrototype

Class	ModeDeclarationMappingSet			
Package	M2::AUTOSARTemplates::SWComponentTemplate::PortInterface			
Note	This meta-class implements a container for ModeDeclarationGroupMappings Tags: atp.recommendedPackage=PortInterfaceMappingSets			
Base	ARElement, ARObject, AtpClassifier, AtpType, CollectableElement, Identifiable , MultilanguageReferrable , PackageableElement , Referrable			
Aggregated by	ARPackage.element			
Attribute	Type	Mult.	Kind	Note
modeDeclarationMapping	ModeDeclarationMapping	*	aggr	This represents the collection of ModeDeclarationMappings owned by the enclosing ModeDeclarationMappingSet.

Table B.87: ModeDeclarationMappingSet

Class	ModeErrorBehavior			
Package	M2::AUTOSARTemplates::CommonStructure::ModeDeclaration			
Note	This represents the ability to define the error behavior in the context of mode handling.			
Base	ARObject			
Aggregated by	ModeDeclarationGroup.modeManagerErrorBehavior , ModeDeclarationGroup.modeUserErrorBehavior			
Attribute	Type	Mult.	Kind	Note
defaultMode	ModeDeclaration	0..1	ref	This represents the ModeDeclaration that is considered the error mode in the context of the enclosing ModeDeclarationGroup.
errorReactionPolicy	ModeErrorReactionPolicyEnum	0..1	attr	This represents the ability to define the policy in terms of which default model shall apply in case an error occurs.

Table B.88: ModeErrorBehavior

Class	ModeSwitchInterface			
Package	M2::AUTOSARTemplates::SWComponentTemplate::PortInterface			
Note	A mode switch interface declares a ModeDeclarationGroupPrototype to be sent and received. Tags: atp.recommendedPackage=PortInterfaces			
Base	ARElement , ARObject , AtpBlueprint , AtpBlueprintable , AtpClassifier , AtpType , CollectableElement , Identifiable , MultilanguageReferrable , PackageableElement , PortInterface , Referrable			
Aggregated by	ARPackage.element			
Attribute	Type	Mult.	Kind	Note
modeGroup	ModeDeclarationGroupPrototype	0..1	aggr	The ModeDeclarationGroupPrototype of this mode interface.

Table B.89: ModeSwitchInterface

Class	ModeSwitchPoint			
Package	M2::AUTOSARTemplates::SWComponentTemplate::SwcInternalBehavior::ModeDeclarationGroup			
Note	A ModeSwitchPoint is required by a RunnableEntity owned a Mode Manager. Its semantics implies the ability to initiate a mode switch.			
Base	ARObject , AbstractAccessPoint , AtpClassifier , AtpFeature , AtpStructureElement , Identifiable , MultilanguageReferrable , Referrable			
Aggregated by	AtpClassifier.atpFeature , RunnableEntity.modeSwitchPoint			
Attribute	Type	Mult.	Kind	Note
modeGroup	ModeDeclarationGroupPrototype	0..1	iref	The mode declaration group that is switched by this runnable. InstanceRef implemented by: PModeGroupInAtomicSwcInstanceRef

Table B.90: ModeSwitchPoint

Class	ModeTransition			
Package	M2::AUTOSARTemplates::CommonStructure::ModeDeclaration			
Note	This meta-class represents the ability to describe possible ModeTransitions in the context of a Mode DeclarationGroup.			
Base	ARObject , AtpClassifier , AtpFeature , AtpStructureElement , Identifiable , MultilanguageReferrable , Referrable			
Aggregated by	AtpClassifier.atpFeature , ModeDeclarationGroup.modeTransition			
Attribute	Type	Mult.	Kind	Note
enteredMode	ModeDeclaration	0..1	ref	This represents the entered model of the ModeTransition.
exitedMode	ModeDeclaration	0..1	ref	This represents the exited mode of the ModeTransition

Table B.91: ModeTransition

Enumeration	MonotonyEnum			
Package	M2::AUTOSARTemplates::GenericStructure::GeneralTemplateClasses::PrimitiveTypes			
Note	This enumerator denotes the values for specification of monotony for e.g. curves.			
Aggregated by	InternalConstrs.monotony , PhysConstrs.monotony , SwCalprmAxisTypeProps.monotony			
Literal	Description			
decreasing	This indicates that the related curve needs to be monotony decreasing. Tags: atp.EnumerationLiteralIndex=0			





Enumeration	MonotonyEnum
increasing	This indicates that the related curve needs to be monotony increasing. Tags: atp.EnumerationLiteralIndex=1
monotonous	This indicates that the values shall be monotonously decreasing or increasing, depending on the trend set by the first values of the series. Tags: atp.EnumerationLiteralIndex=2
noMonotony	This indicates that the related curve needs not to be monotony. Tags: atp.EnumerationLiteralIndex=3
strictlyDecreasing	This indicates that the related curve needs to be strictly monotony decreasing. Tags: atp.EnumerationLiteralIndex=4
strictlyIncreasing	This indicates that the related curve needs to be strictly monotony increasing. Tags: atp.EnumerationLiteralIndex=5
strictMonotonous	This indicates that the values shall be strict monotonously decreasing or increasing, depending on the trend set by the first values of the series. Tags: atp.EnumerationLiteralIndex=6

Table B.92: MonotonyEnum

Class	NonqueuedReceiverComSpec			
Package	M2::AUTOSARTemplates::SWComponentTemplate::Communication			
Note	Communication attributes specific to non-queued receiving.			
Base	ARObject, RPortComSpec, ReceiverComSpec			
Aggregated by	AbstractRequiredPortPrototype.requiredComSpec, PortPrototypeBlueprint.requiredComSpec			
Attribute	Type	Mult.	Kind	Note
aliveTimeout	TimeValue	0..1	attr	Specify the amount of time (in seconds) after which the software component (via the RTE) needs to be notified if the corresponding data item have not been received according to the specified timing description. If the aliveTimeout attribute is 0 no timeout monitoring shall be performed.
enableUpdate	Boolean	0..1	attr	This attribute controls whether application code is entitled to check whether the value of the corresponding VariableDataPrototype has been updated.
filter	DataFilter	0..1	aggr	The applicable filter algorithm for filtering the value of the corresponding dataElement.
handleData Status	Boolean	0..1	attr	If this attribute is set to true, then the Rte_IStatus API shall exist. If the attribute does not exist or is set to false, then the Rte_IStatus API may still exist in response to the existence of further conditions.
handleNever Received	Boolean	0..1	attr	This attribute specifies whether for the corresponding VariableDataPrototype the "never received" flag is available. If yes, the RTE is supposed to assume that initially the VariableDataPrototype has not been received before. After the first reception of the corresponding VariableDataPrototype the flag is cleared. <ul style="list-style-type: none"> • If the value of this attribute is set to "true" the flag is required. • If set to "false", the RTE shall not support the "never received" functionality for the corresponding VariableDataPrototype.
handleTimeout Type	HandleTimeoutEnum	0..1	attr	This attribute controls the behavior with respect to the handling of timeouts.





Class	NonqueuedReceiverComSpec			
initValue	ValueSpecification	0..1	aggr	Initial value to be used in case the sending component is not yet initialized. If the sender also specifies an initial value, then the receiver's value will be used.
timeout Substitution Value	ValueSpecification	0..1	aggr	This attribute represents the substitution value applicable in the case of a timeout.

Table B.93: NonqueuedReceiverComSpec

Class	NonqueuedSenderComSpec			
Package	M2::AUTOSARTemplates::SWComponentTemplate::Communication			
Note	Communication attributes for non-queued sender/receiver communication (sender side)			
Base	ARObject, PPortComSpec, SenderComSpec			
Aggregated by	AbstractProvidedPortPrototype.providedComSpec, PortPrototypeBlueprint.providedComSpec			
Attribute	Type	Mult.	Kind	Note
dataFilter	DataFilter	0..1	aggr	The applicable filter algorithm for filtering the value of the corresponding dataElement.
initValue	ValueSpecification	0..1	aggr	Initial value to be sent if sender component is not yet fully initialized, but receiver needs data already.

Table B.94: NonqueuedSenderComSpec

Class	NvBlockNeeds			
Package	M2::AUTOSARTemplates::CommonStructure::ServiceNeeds			
Note	Specifies the abstract needs on the configuration of a single NVRAM Block.			
Base	ARObject, Identifiable, MultilanguageReferrable, Referrable, ServiceNeeds			
Aggregated by	BswServiceDependency.serviceNeeds, NvBlockDescriptor.nvBlockNeeds, SwcServiceDependency.serviceNeeds			
Attribute	Type	Mult.	Kind	Note
calcRamBlock Crc	Boolean	0..1	attr	Defines if CRC (re)calculation for the permanent RAM Block is required.
checkStatic BlockId	Boolean	0..1	attr	Defines if the Static Block Id check shall be enabled.
cyclicWriting Period	TimeValue	0..1	attr	This represents the period for cyclic writing of NvData to store the associated RAM Block.
nDataSets	PositiveInteger	0..1	attr	Number of data sets to be provided by the NVRAM manager for this block. This is the total number of ROM Blocks and RAM Blocks.
nRomBlocks	PositiveInteger	0..1	attr	Number of ROM Blocks to be provided by the NVRAM manager for this block. Please note that these multiple ROM Blocks are given in a contiguous area.
ramBlockStatus Control	RamBlockStatusControl Enum	0..1	attr	This attribute defines how the management of the RAM Block status is controlled.
readonly	Boolean	0..1	attr	true: data of this NVRAM Block are write protected for normal operation (but protection can be disabled) false: no restriction
reliability	NvBlockNeeds ReliabilityEnum	0..1	attr	Reliability against data loss on the non-volatile medium.





Class	NvBlockNeeds			
resistantTo ChangedSw	Boolean	0..1	attr	Defines whether an NVRAM Block shall be treated resistant to configuration changes (true) or not (false). For details how to handle initialization in the latter case, please refer to the NVRAM specification.
restoreAtStart	Boolean	0..1	attr	Defines whether the associated RAM Block shall be implicitly restored during startup by the basic software.
selectBlockFor FirstInitAll	Boolean	0..1	attr	If this attribute is set to true the NvM shall process this block in the NvM_FirstInitAll() function.
storeAt Shutdown	Boolean	0..1	attr	Defines whether or not the associated RAM Block shall be implicitly stored during shutdown by the basic software.
storeCyclic	Boolean	0..1	attr	Defines whether or not the associated RAM Block shall be implicitly stored periodically by the basic software.
store Emergency	Boolean	0..1	attr	Defines whether or not the associated RAM Block shall be implicitly stored in case of ECU failure (e.g. loss of power) by the basic software. If the attribute store Emergency is set to true the associated RAM Block shall be configured to have immediate priority.
storeImmediate	Boolean	0..1	attr	Defines whether or not the associated RAM Block shall be implicitly stored immediately during or after execution of the according SW-C RunnableEntity by the basic software.
storeOnChange	Boolean	0..1	attr	This attribute defines whether the associated RAM Block shall be stored immediately if the written value is different to the value stored in the associated RAM Block(s) during or after execution of the according SW-C RunnableEntity.
useAuto ValidationAt ShutDown	Boolean	0..1	attr	If set to true the RAM Block shall be auto validated during shutdown phase.
useCRCComp Mechanism	Boolean	0..1	attr	If set to true the CRC of the RAM Block shall be compared during a write job with the CRC which was calculated during the last successful read or write job in order to skip unnecessary NVRAM writings.
writeOnlyOnce	Boolean	0..1	attr	Defines write protection after first write: true: This block is prevented from being changed/erased or being replaced with the default ROM data after first initialization by the software-component. false: No such restriction.
writeVerification	Boolean	0..1	attr	Defines if Write Verification shall be enabled for this NVRAM Block.
writing Frequency	PositiveInteger	0..1	attr	Provides the amount of updates to this block from the application point of view. It has to be provided in "number of write access per year".
writingPriority	NvBlockNeedsWriting PriorityEnum	0..1	attr	Requires the priority of writing this block in case of concurrent requests to write other blocks.

Table B.95: NvBlockNeeds

Class	NvDataInterface
Package	M2::AUTOSARTemplates::SWComponentTemplate::PortInterface
Note	A non volatile data interface declares a number of VariableDataPrototypes to be exchanged between non volatile block components and atomic software components. Tags: atp.recommendedPackage=PortInterfaces





Class	NvDataInterface			
Base	<i>ARElement, ARObject, AtpBlueprint, AtpBlueprintable, AtpClassifier, AtpType, CollectableElement, DataInterface, Identifiable, MultilanguageReferrable, PackageableElement, PortInterface, Referrable</i>			
Aggregated by	ARPackage.element			
Attribute	Type	Mult.	Kind	Note
nvData	VariableDataPrototype	*	aggr	The VariableDataPrototype of this nv data interface.

Table B.96: NvDataInterface

Class	OperationInvokedEvent			
Package	M2::AUTOSARTemplates::SWComponentTemplate::SwcInternalBehavior::RTEEvents			
Note	This event is raised when the ClientServerOperation referenced in OperationInvokedEvent.operation shall be invoked.			
Base	<i>ARObject, AbstractEvent, AtpClassifier, AtpFeature, AtpStructureElement, Identifiable, MultilanguageReferrable, RTEEvent, Referrable</i>			
Aggregated by	<i>AtpClassifier.atpFeature, SwcInternalBehavior.event</i>			
Attribute	Type	Mult.	Kind	Note
operation	ClientServerOperation	0..1	iref	This represents the ClientServerOperation which shall be invoked. InstanceRef implemented by: POperationInAtomicSwc InstanceRef

Table B.97: OperationInvokedEvent

Class	OsTaskExecutionEvent			
Package	M2::AUTOSARTemplates::SWComponentTemplate::SwcInternalBehavior::RTEEvents			
Note	This RTEEvent is supposed to execute RunnableEntities which have to react on the execution of specific OsTasks. Therefore, this event is unconditionally raised whenever the OsTask on which it is mapped is executed. The main use case for this event is scheduling of Runnables of Complex Drivers which have to react on task executions. Tags: atp.Status=draft			
Base	<i>ARObject, AbstractEvent, AtpClassifier, AtpFeature, AtpStructureElement, Identifiable, MultilanguageReferrable, RTEEvent, Referrable</i>			
Aggregated by	<i>AtpClassifier.atpFeature, SwcInternalBehavior.event</i>			
Attribute	Type	Mult.	Kind	Note
–	–	–	–	–

Table B.98: OsTaskExecutionEvent

Class	PPortPrototype			
Package	M2::AUTOSARTemplates::SWComponentTemplate::Components			
Note	Component port providing a certain port interface.			
Base	<i>ARObject, AbstractProvidedPortPrototype, AtpBlueprintable, AtpFeature, AtpPrototype, Identifiable, MultilanguageReferrable, PortPrototype, Referrable</i>			
Aggregated by	<i>AtpClassifier.atpFeature, SwComponentType.port</i>			
Attribute	Type	Mult.	Kind	Note
provided Interface	PortInterface	0..1	tref	The interface that this port provides. Stereotypes: isOfType

Table B.99: PPortPrototype

Class	PRPortPrototype			
Package	M2::AUTOSARTemplates::SWComponentTemplate::Components			
Note	This kind of PortPrototype can take the role of both a required and a provided PortPrototype.			
Base	ARObject, AbstractProvidedPortPrototype, AbstractRequiredPortPrototype, AtpBlueprintable, AtpFeature, AtpPrototype, Identifiable, MultilanguageReferrable, PortPrototype, Referrable			
Aggregated by	AtpClassifier.atpFeature, SwComponentType.port			
Attribute	Type	Mult.	Kind	Note
provided Required Interface	PortInterface	0..1	tref	This represents the PortInterface used to type the PRPort Prototype Stereotypes: isOfType

Table B.100: PRPortPrototype

Class	ParameterAccess			
Package	M2::AUTOSARTemplates::SWComponentTemplate::SwcInternalBehavior::DataElements			
Note	The presence of a ParameterAccess implies that a RunnableEntity needs access to a ParameterData Prototype.			
Base	ARObject, AbstractAccessPoint, AtpClassifier, AtpFeature, AtpStructureElement, Identifiable, MultilanguageReferrable, Referrable			
Aggregated by	AtpClassifier.atpFeature, RunnableEntity.parameterAccess			
Attribute	Type	Mult.	Kind	Note
accessed Parameter	AutosarParameterRef	0..1	aggr	Reference to the accessed calibration parameter.
swDataDef Props	SwDataDefProps	0..1	aggr	This allows denote instance and access specific properties, mainly input values and common axis. Stereotypes: atpSplitable Tags: atp.Splitkey=swDataDefProps

Table B.101: ParameterAccess

Class	ParameterDataPrototype			
Package	M2::AUTOSARTemplates::SWComponentTemplate::Datatype::DataPrototypes			
Note	A ParameterDataPrototype represents a formalized generic piece of information that is typically immutable by the application software layer, but mutable by measurement and calibration tools. ParameterDataPrototype is used in various contexts and the specific context gives the otherwise generic ParameterDataPrototype a dedicated semantics.			
Base	ARObject, AtpFeature, AtpPrototype, AutosarDataPrototype, DataPrototype, Identifiable, Multilanguage Referrable, Referrable			
Aggregated by	AtpClassifier.atpFeature, BswInternalBehavior.perInstanceParameter, InternalBehavior.constant Memory, NvBlockDescriptor.romBlock, ParameterInterface.parameter, SwcInternalBehavior.perInstance Parameter, SwcInternalBehavior.sharedParameter			
Attribute	Type	Mult.	Kind	Note
initValue	ValueSpecification	0..1	aggr	Specifies initial value(s) of the ParameterDataPrototype

Table B.102: ParameterDataPrototype

Class	ParameterInterface			
Package	M2::AUTOSARTemplates::SWComponentTemplate::PortInterface			
Note	A parameter interface declares a number of parameter and characteristic values to be exchanged between parameter components and software components. Tags: atp.recommendedPackage=PortInterfaces			
Base	<i>ARElement</i> , <i>ARObject</i> , <i>AtpBlueprint</i> , <i>AtpBlueprintable</i> , <i>AtpClassifier</i> , <i>AtpType</i> , <i>CollectableElement</i> , <i>DataInterface</i> , <i>Identifiable</i> , <i>MultilanguageReferrable</i> , <i>PackageableElement</i> , <i>PortInterface</i> , <i>Referrable</i>			
Aggregated by	ARPackage.element			
Attribute	Type	Mult.	Kind	Note
parameter	ParameterData Prototype	*	aggr	The ParameterDataPrototype of this ParameterInterface.

Table B.103: ParameterInterface

Class	ParameterRequireComSpec			
Package	M2::AUTOSARTemplates::SWComponentTemplate::Communication			
Note	"Communication" specification that applies to parameters on the required side of a connection.			
Base	<i>ARObject</i> , <i>RPortComSpec</i>			
Aggregated by	<i>AbstractRequiredPortPrototype.requiredComSpec</i> , <i>PortPrototypeBlueprint.requiredComSpec</i>			
Attribute	Type	Mult.	Kind	Note
initValue	ValueSpecification	0..1	aggr	The initial value applicable for the corresponding ParameterDataPrototype.
parameter	ParameterData Prototype	0..1	ref	The ParameterDataPrototype to which the Parameter RequireComSpec applies.

Table B.104: ParameterRequireComSpec

Class	PhysConstrs			
Package	M2::MSR::AsamHdo::Constraints::GlobalConstraints			
Note	This meta-class represents the ability to express physical constraints. Therefore it has (in opposite to InternalConstrs) a reference to a Unit.			
Base	<i>ARObject</i>			
Aggregated by	DataConstrRule.physConstrs			
Attribute	Type	Mult.	Kind	Note
lowerLimit	Limit	0..1	attr	This specifies the lower limit of the constraint. Stereotypes: atpVariation Tags: vh.latestBindingTime=preCompileTime xml.sequenceOffset=20
maxDiff	Numerical	0..1	attr	Maximum difference that is permitted between two consecutive values if the constraint is applied to an axis. Tags: xml.sequenceOffset=60
maxGradient	Numerical	0..1	attr	This element specifies the maximum slope that may be used in curves and maps. Tags: xml.sequenceOffset=50
monotony	MonotonyEnum	0..1	attr	This specifies the monotony constraints on the data object. Note that this applies only to curves and maps. Tags: xml.sequenceOffset=70





Class	PhysConstrs			
scaleConstr (ordered)	ScaleConstr	*	aggr	This is one particular scale which contributes to the data constraints. Tags: xml.roleElement=true xml.roleWrapperElement=true xml.sequenceOffset=40 xml.typeElement=false xml.typeWrapperElement=false
unit	Unit	0..1	ref	This is the unit to which the physical constraints relate to. In particular, it is the physical unit of the specified limits. Tags: xml.sequenceOffset=80
upperLimit	Limit	0..1	attr	This specifies the upper limit of the constraint. Stereotypes: atpVariation Tags: vh.latestBindingTime=preCompileTime xml.sequenceOffset=30

Table B.105: PhysConstrs

Class	PhysicalDimension				
Package	M2::MSR::AsamHdo::Units				
Note	<p>This class represents a physical dimension. If the physical dimension of two units is identical, then a conversion between them is possible. The conversion between units is related to the definition of the physical dimension.</p> <p>Note that the equivalence of the exponents does not per se define the convertibility. For example Energy and Torque share the same exponents (Nm).</p> <p>Please note further the value of an exponent does not necessarily have to be an integer number. It is also possible that the value yields a rational number, e.g. to compute the square root of a given physical quantity. In this case the exponent value would be a rational number where the numerator value is 1 and the denominator value is 2.</p> <p>Tags:atp.recommendedPackage=PhysicalDimensions</p>				
Base	<i>ARElement, ARObject, CollectableElement, Identifiable, MultilanguageReferrable, PackageableElement, Referrable</i>				
Aggregated by	ARPackage.element				
Attribute	Type	Mult.	Kind	Note	
currentExp	Numerical	0..1	attr	This attribute represents the exponent of the physical dimension "electric current". Tags: xml.sequenceOffset=50	
lengthExp	Numerical	0..1	attr	The exponent of the physical dimension "length". Tags: xml.sequenceOffset=20	
luminous IntensityExp	Numerical	0..1	attr	The exponent of the physical dimension "luminous intensity". Tags: xml.sequenceOffset=80	
massExp	Numerical	0..1	attr	The exponent of the physical dimension "mass". Tags: xml.sequenceOffset=30	
molarAmount Exp	Numerical	0..1	attr	The exponent of the physical dimension "quantity of substance". Tags: xml.sequenceOffset=70	





Class	PhysicalDimension			
temperatureExp	Numerical	0..1	attr	The exponent of the physical dimension "temperature". Tags: xml.sequenceOffset=60
timeExp	Numerical	0..1	attr	The exponent of the physical dimension "time". Tags: xml.sequenceOffset=40

Table B.106: PhysicalDimension

Class	PortElementToCommunicationResourceMapping			
Package	M2::AUTOSARTemplates::SystemTemplate			
Note	This meta class maps a communication resource to CP Software Clusters. In this case the kind of Port Prototype specified whether the Software Cluster has to provide or to require the resource. Tags: atp.Status=draft			
Base	ARObject, Identifiable , MultilanguageReferrable , Referrable			
Aggregated by	CpSoftwareClusterMappingSet.portElementToComResourceMapping, SystemMapping.portElementToComResourceMapping			
Attribute	Type	Mult.	Kind	Note
clientServerOperation	ClientServerOperation	0..1	iref	ClientServerOperation instance qualifying the communication resource Tags: atp.Status=draft InstanceRef implemented by: OperationInSystemInstanceRef
communicationResource	CpSoftwareClusterCommunicationResource	0..1	ref	Communication resource for which the mapping applies. Tags: atp.Status=draft
modeDeclarationGroupPrototype	ModeDeclarationGroupPrototype	0..1	iref	ModeDeclarationGroupPrototype instance qualifying the communication resource Tags: atp.Status=draft InstanceRef implemented by: ModeDeclarationGroupPrototypeInSystemInstanceRef
parameterDataPrototype	ParameterDataPrototype	0..1	iref	ParameterDataPrototype instance qualifying the communication resource. Tags: atp.Status=draft InstanceRef implemented by: ParameterDataPrototypeInSystemInstanceRef
trigger	Trigger	0..1	iref	Trigger instance qualifying the communication resource. Tags: atp.Status=draft InstanceRef implemented by: TriggerInSystemInstanceRef
variableDataPrototype	VariableDataPrototype	0..1	iref	VariableDataPrototype instance qualifying the communication resource Tags: atp.Status=draft InstanceRef implemented by: VariableDataPrototypeInSystemInstanceRef

Table B.107: PortElementToCommunicationResourceMapping

Class	PortInterface (abstract)			
Package	M2::AUTOSARTemplates::SWComponentTemplate::PortInterface			
Note	Abstract base class for an interface that is either provided or required by a port of a software component.			
Base	ARElement , ARObject , AtpBlueprint , AtpBlueprintable , AtpClassifier , AtpType , CollectableElement , Identifiable , MultilanguageReferrable , PackageableElement , Referrable			
Subclasses	ClientServerInterface , DataInterface , ModeSwitchInterface , TriggerInterface			
Aggregated by	ARPackage.element			
Attribute	Type	Mult.	Kind	Note
isService	Boolean	0..1	attr	<p>This flag is set if the PortInterface is to be used for communication between an</p> <ul style="list-style-type: none"> • ApplicationSwComponentType or • ServiceProxySwComponentType or • SensorActuatorSwComponentType or • ComplexDeviceDriverSwComponentType • ServiceSwComponentType • EcuAbstractionSwComponentType <p>and a ServiceSwComponentType (namely an AUTOSAR Service) located on the same ECU. Otherwise the flag is not set.</p> <p>Stereotypes: atpVariation Tags: vh.latestBindingTime=blueprintDerivationTime</p>
serviceKind	ServiceProviderEnum	0..1	attr	This attribute provides further details about the nature of the applied service.

Table B.108: PortInterface

Class	PortInterfaceMapping (abstract)			
Package	M2::AUTOSARTemplates::SWComponentTemplate::PortInterface			
Note	Specifies one PortInterfaceMapping to support the connection of Ports typed by two different Port Interfaces with PortInterface elements having unequal names and/or unequal semantic (resolution or range).			
Base	ARObject , AtpBlueprint , AtpBlueprintable , Identifiable , MultilanguageReferrable , Referrable			
Subclasses	ClientServerInterfaceMapping , ModelInterfaceMapping , TriggerInterfaceMapping , VariableAndParameterInterfaceMapping			
Aggregated by	PortInterfaceMappingSet.portInterfaceMapping			
Attribute	Type	Mult.	Kind	Note
–	–	–	–	–

Table B.109: PortInterfaceMapping

Class	PortPrototype (abstract)			
Package	M2::AUTOSARTemplates::SWComponentTemplate::Components			
Note	<p>Base class for the ports of an AUTOSAR software component.</p> <p>The aggregation of PortPrototypes is subject to variability with the purpose to support the conditional existence of ports.</p>			
Base	ARObject , AtpBlueprintable , AtpFeature , AtpPrototype , Identifiable , MultilanguageReferrable , Referrable			
Subclasses	AbstractProvidedPortPrototype , AbstractRequiredPortPrototype			
Aggregated by	AtpClassifier.atpFeature , SwComponentType.port			
Attribute	Type	Mult.	Kind	Note





Class	PortPrototype (abstract)			
clientServer Annotation	ClientServerAnnotation	*	aggr	Annotation of this PortPrototype with respect to client/server communication.
delegatedPort Annotation	DelegatedPort Annotation	0..1	aggr	Annotations on this delegated port.
ioHwAbstraction Server Annotation	IoHwAbstractionServer Annotation	*	aggr	Annotations on this IO Hardware Abstraction port.
modePort Annotation	ModePortAnnotation	*	aggr	Annotations on this mode port.
nvDataPort Annotation	NvDataPortAnnotation	*	aggr	Annotations on this non volatile data port.
parameterPort Annotation	ParameterPort Annotation	*	aggr	Annotations on this parameter port.
senderReceiver Annotation	SenderReceiver Annotation	*	aggr	Collection of annotations of this ports sender/receiver communication.
triggerPort Annotation	TriggerPortAnnotation	*	aggr	Annotations on this trigger port.

Table B.110: PortPrototype

Class	QueuedReceiverComSpec			
Package	M2::AUTOSARTemplates::SWComponentTemplate::Communication			
Note	Communication attributes specific to queued receiving.			
Base	<i>ARObject, RPortComSpec, ReceiverComSpec</i>			
Aggregated by	<i>AbstractRequiredPortPrototype.requiredComSpec, PortPrototypeBlueprint.requiredComSpec</i>			
Attribute	Type	Mult.	Kind	Note
queueLength	PositiveInteger	0..1	attr	Length of queue for received events.

Table B.111: QueuedReceiverComSpec

Class	RModelInAtomicSwcInstanceRef			
Package	M2::AUTOSARTemplates::SWComponentTemplate::Components::InstanceRefs			
Note				
Base	<i>ARObject, AtpInstanceRef</i>			
Aggregated by	<i>RTEEvent.disabledMode, SwcModeSwitchEvent.mode</i>			
Attribute	Type	Mult.	Kind	Note
base	AtomicSwComponent Type	0..1	ref	Stereotypes: atpDerived Tags: xml.sequenceOffset=10
contextMode Declaration GroupPrototype	ModeDeclarationGroup Prototype	0..1	ref	Tags: xml.sequenceOffset=30
contextPort	AbstractRequiredPort Prototype	0..1	ref	Tags: xml.sequenceOffset=20
targetMode Declaration	ModeDeclaration	0..1	ref	Tags: xml.sequenceOffset=40

Table B.112: RModelInAtomicSwcInstanceRef

Class	RPortPrototype			
Package	M2::AUTOSARTemplates::SWComponentTemplate::Components			
Note	Component port requiring a certain port interface.			
Base	<i>ARObject, AbstractRequiredPortPrototype, AtpBlueprintable, AtpFeature, AtpPrototype, Identifiable, MultilanguageReferrable, PortPrototype, Referrable</i>			
Aggregated by	<i>AtpClassifier.atpFeature, SwComponentType.port</i>			
Attribute	Type	Mult.	Kind	Note
mayBeUnconnected	Boolean	0..1	attr	If set to true, this attribute indicates that the enclosing RPortPrototype may be left unconnected and that this aspect has explicitly been considered in the software-component's design.
requiredInterface	PortInterface	0..1	tref	The interface that this port requires. Stereotypes: isOfType

Table B.113: RPortPrototype

Class	RTEEvent (abstract)			
Package	M2::AUTOSARTemplates::SWComponentTemplate::SwcInternalBehavior::RTEEvents			
Note	Abstract base class for all RTE-related events			
Base	<i>ARObject, AbstractEvent, AtpClassifier, AtpFeature, AtpStructureElement, Identifiable, MultilanguageReferrable, Referrable</i>			
Subclasses	AsynchronousServerCallReturnsEvent , BackgroundEvent , DataReceiveErrorEvent , DataReceivedEvent , DataSendCompletedEvent , DataWriteCompletedEvent , ExternalTriggerOccurredEvent , InitEvent , InternalTriggerOccurredEvent , ModeSwitchedAckEvent , OperationInvokedEvent , OsTaskExecutionEvent , SwcModeManagerErrorEvent , SwcModeSwitchEvent , TimingEvent , TransformerHardErrorEvent			
Aggregated by	<i>AtpClassifier.atpFeature, SwcInternalBehavior.event</i>			
Attribute	Type	Mult.	Kind	Note
disabledMode	ModeDeclaration	*	iref	Reference to the Modes that disable the Event. Stereotypes: atpSplitable Tags: atp.Splitkey=disabledMode.contextPort, disabledMode.contextModeDeclarationGroupPrototype, disabledMode.targetModeDeclaration InstanceRef implemented by: RModeInAtomicSwcInstanceRef
startOnEvent	RunnableEntity	0..1	ref	The referenced RunnableEntity starts when the corresponding RTEEvent is raised.

Table B.114: RTEEvent

Class	RTriggerInAtomicSwcInstanceRef			
Package	M2::AUTOSARTemplates::SWComponentTemplate::Components::InstanceRefs			
Note				
Base	<i>ARObject, AtpInstanceRef, TriggerInAtomicSwcInstanceRef</i>			
Aggregated by	ExternalTriggerOccurredEvent.trigger , TransformerHardErrorEvent.requiredTrigger			
Attribute	Type	Mult.	Kind	Note
contextRPort	AbstractRequiredPortPrototype	0..1	ref	Tags: xml.sequenceOffset=20
targetTrigger	Trigger	0..1	ref	Tags: xml.sequenceOffset=30

Table B.115: RTriggerInAtomicSwcInstanceRef

Class	Referrable (abstract)			
Package	M2::AUTOSARTemplates::GenericStructure::GeneralTemplateClasses::Identifiable			
Note	Instances of this class can be referred to by their identifier (while adhering to namespace borders).			
Base	ARObject			
Subclasses	AtpDefinition, BswDistinguishedPartition, BswModuleCallPoint, BswModuleClientServerEntry, BswVariableAccess, CouplingPortTrafficClassAssignment, DiagnosticEnvModeElement, EthernetPriorityRegeneration, ExclusiveAreaNestingOrder, HwDescriptionEntity, ImplementationProps, LinSlaveConfigIdent, ModeTransition, MultilanguageReferrable, PncMappingIdent, SingleLanguageReferrable, SoConlPdulIdentifier, SocketConnectionBundle, TimeSyncServerConfiguration, TpConnectionIdent			
Attribute	Type	Mult.	Kind	Note
shortName	Identifier	1	attr	This specifies an identifying shortName for the object. It needs to be unique within its context and is intended for humans but even more for technical reference. Stereotypes: atpIdentityContributor Tags: xml.enforceMinMultiplicity=true xml.sequenceOffset=-100
shortName Fragment	ShortNameFragment	*	aggr	This specifies how the Referrable.shortName is composed of several shortNameFragments. Tags: xml.sequenceOffset=-90

Table B.116: Referrable

Class	RtePluginProps			
Package	M2::AUTOSARTemplates::CommonStructure::FlatMap			
Note	The properties of a communication graph with respect to the utilization of RTE Implementation Plug-in.			
Base	ARObject			
Aggregated by	FlatInstanceDescriptor.rtePluginProps			
Attribute	Type	Mult.	Kind	Note
associated CrossSwCluster ComRtePlugin	EucucContainerValue	0..1	ref	This associates a communication graph to a specific RTE Implementation Plug-in handling cross Software Cluster communication.
associatedRte Plugin	EucucContainerValue	0..1	ref	This associates a communication graph to a specific RTE Implementation Plug-in handling local Software Cluster communication or communication in a non-cluster ECU.

Table B.117: RtePluginProps

Class	RunnableEntity			
Package	M2::AUTOSARTemplates::SWComponentTemplate::SwcInternalBehavior			
Note	A RunnableEntity represents the smallest code-fragment that is provided by an AtomicSwComponent Type and are executed under control of the RTE. RunnableEntities are for instance set up to respond to data reception or operation invocation on a server.			
Base	ARObject, AtpClassifier, AtpFeature, AtpStructureElement, ExecutableEntity, Identifiable, MultilanguageReferrable, Referrable			
Aggregated by	AtpClassifier.atpFeature, SwcInternalBehavior.runnable			
Attribute	Type	Mult.	Kind	Note
argument (ordered)	RunnableEntity Argument	*	aggr	This represents the formal definition of an argument to a RunnableEntity.





Class	RunnableEntity			
asynchronous ServerCall ResultPoint	AsynchronousServer CallResultPoint	*	aggr	<p>The server call result point admits a runnable to fetch the result of an asynchronous server call.</p> <p>The aggregation of AsynchronousServerCallResultPoint is subject to variability with the purpose to support the conditional existence of client server PortPrototypes and the variant existence of server call result points in the implementation.</p> <p>Stereotypes: atpSplitable; atpVariation Tags: atp.Splitkey=asynchronousServerCallResultPoint.shortName, asynchronousServerCallResultPoint.variationPoint.shortLabel vh.latestBindingTime=preCompileTime</p>
canBelvoked Concurrently	Boolean	0..1	attr	<p>If the value of this attribute is set to "true" the enclosing RunnableEntity can be invoked concurrently (even for one instance of the corresponding AtomicSwComponent Type). This implies that it is the responsibility of the implementation of the RunnableEntity to take care of this form of concurrency.</p>
dataRead Access	VariableAccess	*	aggr	<p>RunnableEntity has implicit read access to dataElement of a sender-receiver PortPrototype or nv data of a nv data PortPrototype.</p> <p>The aggregation of dataReadAccess is subject to variability with the purpose to support the conditional existence of sender receiver ports or the variant existence of dataReadAccess in the implementation.</p> <p>Stereotypes: atpSplitable; atpVariation Tags: atp.Splitkey=dataReadAccess.shortName, dataReadAccess.variationPoint.shortLabel vh.latestBindingTime=preCompileTime</p>
dataReceive PointBy Argument	VariableAccess	*	aggr	<p>RunnableEntity has explicit read access to dataElement of a sender-receiver PortPrototype or nv data of a nv data PortPrototype. The result is passed back to the application by means of an argument in the function signature.</p> <p>The aggregation of dataReceivePointByArgument is subject to variability with the purpose to support the conditional existence of sender receiver PortPrototype or the variant existence of data receive points in the implementation.</p> <p>Stereotypes: atpSplitable; atpVariation Tags: atp.Splitkey=dataReceivePointByArgument.shortName, dataReceivePointByArgument.variationPoint.shortLabel vh.latestBindingTime=preCompileTime</p>





Class	RunnableEntity			
dataReceivePointByValue	VariableAccess	*	aggr	<p>RunnableEntity has explicit read access to dataElement of a sender-receiver PortPrototype or nv data of a nv data PortPrototype.</p> <p>The result is passed back to the application by means of the return value. The aggregation of dataReceivePointByValue is subject to variability with the purpose to support the conditional existence of sender receiver ports or the variant existence of data receive points in the implementation.</p> <p>Stereotypes: atpSplitable; atpVariation Tags: atp.Splitkey=dataReceivePointByValue.shortName, dataReceivePointByValue.variationPoint.shortLabel vh.latestBindingTime=preCompileTime</p>
dataSendPoint	VariableAccess	*	aggr	<p>RunnableEntity has explicit write access to dataElement of a sender-receiver PortPrototype or nv data of a nv data PortPrototype.</p> <p>The aggregation of dataSendPoint is subject to variability with the purpose to support the conditional existence of sender receiver PortPrototype or the variant existence of data send points in the implementation.</p> <p>Stereotypes: atpSplitable; atpVariation Tags: atp.Splitkey=dataSendPoint.shortName, dataSendPoint.variationPoint.shortLabel vh.latestBindingTime=preCompileTime</p>
dataWriteAccess	VariableAccess	*	aggr	<p>RunnableEntity has implicit write access to dataElement of a sender-receiver PortPrototype or nv data of a nv data PortPrototype.</p> <p>The aggregation of dataWriteAccess is subject to variability with the purpose to support the conditional existence of sender receiver ports or the variant existence of dataWriteAccess in the implementation.</p> <p>Stereotypes: atpSplitable; atpVariation Tags: atp.Splitkey=dataWriteAccess.shortName, dataWriteAccess.variationPoint.shortLabel vh.latestBindingTime=preCompileTime</p>
externalTriggeringPoint	ExternalTriggeringPoint	*	aggr	<p>The aggregation of ExternalTriggeringPoint is subject to variability with the purpose to support the conditional existence of trigger ports or the variant existence of external triggering points in the implementation.</p> <p>Stereotypes: atpSplitable; atpVariation Tags: atp.Splitkey=externalTriggeringPoint.ident.shortName, externalTriggeringPoint.variationPoint.shortLabel vh.latestBindingTime=preCompileTime</p>
internalTriggeringPoint	InternalTriggeringPoint	*	aggr	<p>The aggregation of InternalTriggeringPoint is subject to variability with the purpose to support the variant existence of internal triggering points in the implementation.</p> <p>Stereotypes: atpSplitable; atpVariation Tags: atp.Splitkey=internalTriggeringPoint.shortName, internalTriggeringPoint.variationPoint.shortLabel vh.latestBindingTime=preCompileTime</p>





Class	RunnableEntity			
modeAccess Point	ModeAccessPoint	*	aggr	<p>The runnable has a mode access point. The aggregation of ModeAccessPoint is subject to variability with the purpose to support the conditional existence of mode ports or the variant existence of mode access points in the implementation.</p> <p>Stereotypes: atpSplitable; atpVariation Tags: atp.Splitkey=modeAccessPoint.ident.shortName, modeAccessPoint.variationPoint.shortLabel vh.latestBindingTime=preCompileTime</p>
modeSwitch Point	ModeSwitchPoint	*	aggr	<p>The runnable has a mode switch point. The aggregation of ModeSwitchPoint is subject to variability with the purpose to support the conditional existence of mode ports or the variant existence of mode switch points in the implementation.</p> <p>Stereotypes: atpSplitable; atpVariation Tags: atp.Splitkey=modeSwitchPoint.shortName, modeSwitchPoint.variationPoint.shortLabel vh.latestBindingTime=preCompileTime</p>
parameter Access	ParameterAccess	*	aggr	<p>The presence of a ParameterAccess implies that a RunnableEntity needs read only access to a ParameterDataPrototype which may either be local or within a Port Prototype.</p> <p>The aggregation of ParameterAccess is subject to variability with the purpose to support the conditional existence of parameter ports and component local parameters as well as the variant existence of Parameter Access (points) in the implementation.</p> <p>Stereotypes: atpSplitable; atpVariation Tags: atp.Splitkey=parameterAccess.shortName, parameterAccess.variationPoint.shortLabel vh.latestBindingTime=preCompileTime</p>
readLocal Variable	VariableAccess	*	aggr	<p>The presence of a readLocalVariable implies that a RunnableEntity needs read access to a VariableData Prototype in the role of implicitInterRunnableVariable or explicitInterRunnableVariable.</p> <p>The aggregation of readLocalVariable is subject to variability with the purpose to support the conditional existence of implicitInterRunnableVariable and explicit InterRunnableVariable or the variant existence of read LocalVariable (points) in the implementation.</p> <p>Stereotypes: atpSplitable; atpVariation Tags: atp.Splitkey=readLocalVariable.shortName, readLocalVariable.variationPoint.shortLabel vh.latestBindingTime=preCompileTime</p>
serverCallPoint	ServerCallPoint	*	aggr	<p>The RunnableEntity has a ServerCallPoint. The aggregation of ServerCallPoint is subject to variability with the purpose to support the conditional existence of client server PortPrototypes or the variant existence of server call points in the implementation.</p> <p>Stereotypes: atpSplitable; atpVariation Tags: atp.Splitkey=serverCallPoint.shortName, serverCallPoint.variationPoint.shortLabel vh.latestBindingTime=preCompileTime</p>





Class	RunnableEntity			
symbol	CIdentifier	0..1	attr	The symbol describing this RunnableEntity's entry point. This is considered the API of the RunnableEntity and is required during the RTE contract phase.
waitPoint	WaitPoint	*	aggr	The WaitPoint associated with the RunnableEntity.
writtenLocalVariable	VariableAccess	*	aggr	<p>The presence of a writtenLocalVariable implies that a RunnableEntity needs write access to a VariableData Prototype in the role of implicitInterRunnableVariable or explicitInterRunnableVariable.</p> <p>The aggregation of writtenLocalVariable is subject to variability with the purpose to support the conditional existence of implicitInterRunnableVariable and explicitInterRunnableVariable or the variant existence of writtenLocalVariable (points) in the implementation.</p> <p>Stereotypes: atpSplitable; atpVariation Tags: atp.Splitkey=writtenLocalVariable.shortName, writtenLocalVariable.variationPoint.shortLabel vh.latestBindingTime=preCompileTime</p>

Table B.118: RunnableEntity

Enumeration	SendIndicationEnum
Package	M2::AUTOSARTemplates::SystemTemplate::SoftwareCluster
Note	<p>This meta-class provides a way to specify in which way redundancy shall be applied on collection level.</p> <p>Tags:atp.Status=draft</p>
Aggregated by	DataComProps.sendIndication
Literal	Description
anySendOperation	<p>This value represents the requirement that any send operation of the Software Cluster is indicated.</p> <p>Tags: atp.EnumerationLiteralIndex=2 atp.Status=draft</p>
none	<p>This value represents the requirement that send operations of the Software Cluster are not indicated.</p> <p>Tags: atp.EnumerationLiteralIndex=1 atp.Status=draft</p>

Table B.119: SendIndicationEnum

Class	SenderReceiverInterface			
Package	M2::AUTOSARTemplates::SWComponentTemplate::PortInterface			
Note	<p>A sender/receiver interface declares a number of data elements to be sent and received.</p> <p>Tags:atp.recommendedPackage=PortInterfaces</p>			
Base	ARElement , ARObject , AtpBlueprint , AtpBlueprintable , AtpClassifier , AtpType , CollectableElement , DataInterface , Identifiable , MultilanguageReferrable , PackageableElement , PortInterface , Referrable			
Aggregated by	ARPackage.element			
Attribute	Type	Mult.	Kind	Note
dataElement	VariableDataPrototype	*	aggr	The data elements of this SenderReceiverInterface.
invalidationPolicy	InvalidationPolicy	*	aggr	InvalidationPolicy for a particular dataElement





Class	SenderReceiverInterface			
metaDataItemSet	MetaDatumItemSet	*	aggr	This aggregation defines fixed sets of meta-data items associated with dataElements of the enclosing Sender ReceiverInterface

Table B.120: SenderReceiverInterface

Class	ServerCallPoint (abstract)			
Package	M2::AUTOSARTemplates::SWComponentTemplate::SwcInternalBehavior::ServerCall			
Note	If a RunnableEntity owns a ServerCallPoint it is entitled to invoke a particular ClientServerOperation of a specific RPortPrototype of the corresponding AtomicSwComponentType			
Base	ARObject, AbstractAccessPoint , AtpClassifier , AtpFeature , AtpStructureElement , Identifiable , MultilanguageReferrable , Referrable			
Subclasses	AsynchronousServerCallPoint, SynchronousServerCallPoint			
Aggregated by	AtpClassifier.atpFeature , RunnableEntity.serverCallPoint			
Attribute	Type	Mult.	Kind	Note
operation	ClientServerOperation	0..1	iref	The operation that is called by this runnable. InstanceRef implemented by: ROperationInAtomicSwc InstanceRef
timeout	TimeValue	0..1	attr	Time in seconds before the server call times out and returns with an error message. It depends on the call type (synchronous or asynchronous) how this is reported.

Table B.121: ServerCallPoint

Class	ServerComSpec			
Package	M2::AUTOSARTemplates::SWComponentTemplate::Communication			
Note	Communication attributes for a server port (PPortPrototype and ClientServerInterface).			
Base	ARObject, PPortComSpec			
Aggregated by	AbstractProvidedPortPrototype.providedComSpec , PortPrototypeBlueprint.providedComSpec			
Attribute	Type	Mult.	Kind	Note
operation	ClientServerOperation	0..1	ref	Operation these communication attributes apply to.
queueLength	PositiveInteger	0..1	attr	Length of call queue on the server side. The queue is implemented by the RTE. The value shall be greater or equal to 1. Setting the value of queueLength to 1 implies that incoming requests are rejected while another request that arrived earlier is being processed.
transformationComSpecProps	TransformationComSpecProps	*	aggr	This references the TransformationComSpecProps which define port-specific configuration for data transformation.

Table B.122: ServerComSpec

Class	SubElementMapping			
Package	M2::AUTOSARTemplates::SWComponentTemplate::PortInterface			
Note	This meta-class allows for the definition of mappings of elements of a composite data type.			
Base	ARObject			
Aggregated by	DataPrototypeMapping.subElementMapping			
Attribute	Type	Mult.	Kind	Note





Class	SubElementMapping			
firstElement	SubElementRef	0..1	aggr	This represents the first element referenced in the scope of the mapping. Stereotypes: atpSplittable; atpVariation Tags: atp.Splitkey=firstElement, firstElement.variation Point.shortLabel vh.latestBindingTime=preCompileTime
secondElement	SubElementRef	0..1	aggr	This represents the second element referenced in the scope of the mapping. Stereotypes: atpSplittable; atpVariation Tags: atp.Splitkey=secondElement, secondElement.variation Point.shortLabel vh.latestBindingTime=preCompileTime
textTable Mapping	TextTableMapping	0..2	aggr	This allows for the text-table translation of individual elements of a composite data type.

Table B.123: SubElementMapping

Class	SwBaseType			
Package	M2::MSR::AsamHdo::BaseTypes			
Note	This meta-class represents a base type used within ECU software. Tags: atp.recommendedPackage=BaseTypes			
Base	ARElement, ARObject, AtpBlueprint, AtpBlueprintable, BaseType, CollectableElement, Identifiable, MultilanguageReferrable, PackageableElement, Referrable			
Aggregated by	ARPackage.element			
Attribute	Type	Mult.	Kind	Note
–	–	–	–	–

Table B.124: SwBaseType

Enumeration	SwCalibrationAccessEnum
Package	M2::MSR::DataDictionary::DataDefProperties
Note	Determines the access rights to a data object w.r.t. measurement and calibration.
Aggregated by	ModeDeclarationGroupPrototype.swCalibrationAccess , SwCalprmAxis.swCalibrationAccess , SwDataDefProps.swCalibrationAccess
Literal	Description
notAccessible	The element will not be accessible via MCD tools, i.e. will not appear in the ASAP file. Tags: atp.EnumerationLiteralIndex=0
readOnly	The element will only appear as read-only in an ASAP file. Tags: atp.EnumerationLiteralIndex=1
readWrite	The element will appear in the ASAP file with both read and write access. Tags: atp.EnumerationLiteralIndex=2

Table B.125: SwCalibrationAccessEnum

Class	SwComponentPrototype			
Package	M2::AUTOSARTemplates::SWComponentTemplate::Composition			
Note	Role of a software component within a composition.			
Base	<i>ARObject</i> , <i>AtpFeature</i> , <i>AtpPrototype</i> , <i>Identifiable</i> , <i>MultilanguageReferrable</i> , <i>Referrable</i>			
Aggregated by	<i>AtpClassifier.atpFeature</i> , CompositionSwComponentType.component			
Attribute	Type	Mult.	Kind	Note
type	SwComponentType	0..1	tref	Type of the instance. Stereotypes: isOfType

Table B.126: SwComponentPrototype

Class	<<atpVariation>> SwDataDefProps			
Package	M2::MSR::DataDictionary::DataDefProperties			
Note	<p>This class is a collection of properties relevant for data objects under various aspects. One could consider this class as a "pattern of inheritance by aggregation". The properties can be applied to all objects of all classes in which SwDataDefProps is aggregated.</p> <p>Note that not all of the attributes or associated elements are useful all of the time. Hence, the process definition (e.g. expressed with an OCL or a Document Control Instance MSR-DCI) has the task of implementing limitations.</p> <p>SwDataDefProps covers various aspects:</p> <ul style="list-style-type: none"> • Structure of the data element for calibration use cases: is it a single value, a curve, or a map, but also the recordLayouts which specify how such elements are mapped/converted to the Data Types in the programming language (or in AUTOSAR). This is mainly expressed by properties like swRecordLayout and swCalprmAxisSet • Implementation aspects, mainly expressed by swImplPolicy, swVariableAccessImplPolicy, swAddrMethod, swPointerTargetProps, baseType, implementationDataType and additionalNativeTypeQualifier • Access policy for the MCD system, mainly expressed by swCalibrationAccess • Semantics of the data element, mainly expressed by compuMethod and/or unit, dataConstr, invalidValue • Code generation policy provided by swRecordLayout <p>Tags:vh.latestBindingTime=codeGenerationTime</p>			
Base	<i>ARObject</i>			
Aggregated by	AutosarDataType.swDataDefProps , CompositeNetworkRepresentation.networkRepresentation , DataPrototype.swDataDefProps , DataPrototypeTransformationProps.networkRepresentationProps , DiagnosticDataElement.swDataDefProps , DiagnosticEnvDataElementCondition.swDataDefProps , DltArgument.networkRepresentation , FlatInstanceDescriptor.swDataDefProps , ImplementationDataTypeElement.swDataDefProps , InstantiationDataDefProps.swDataDefProps , ISignal.networkRepresentationProps , McDataInstance.resultingProperties , ParameterAccess.swDataDefProps , PerInstanceMemory.swDataDefProps , ReceiverComSpec.networkRepresentation , SenderComSpec.networkRepresentation , SomeipDataPrototypeTransformationProps.networkRepresentation , SwPointerTargetProps.swDataDefProps , SwServiceArg.swDataDefProps , SwSystemconst.swDataDefProps , SystemSignal.physicalProps			
Attribute	Type	Mult.	Kind	Note
additionalNativeTypeQualifier	NativeDeclarationString	0..1	attr	<p>This attribute is used to declare native qualifiers of the programming language which can neither be deduced from the baseType (e.g. because the data object describes a pointer) nor from other more abstract attributes. Examples are qualifiers like "volatile", "strict" or "enum" of the C-language. All such declarations have to be put into one string.</p> <p>Tags:xml.sequenceOffset=235</p>





Class	<<atpVariation>> SwDataDefProps			
annotation	Annotation	*	aggr	This aggregation allows to add annotations (yellow pads ...) related to the current data object. Tags: xml.roleElement=true xml.roleWrapperElement=true xml.sequenceOffset=20 xml.typeElement=false xml.typeWrapperElement=false
baseType	SwBaseType	0..1	ref	Base type associated with the containing data object. Tags: xml.sequenceOffset=50
compuMethod	CompuMethod	0..1	ref	Computation method associated with the semantics of this data object. Tags: xml.sequenceOffset=180
dataConstr	DataConstr	0..1	ref	Data constraint for this data object. Tags: xml.sequenceOffset=190
displayFormat	DisplayFormatString	0..1	attr	This property describes how a number is to be rendered e.g. in documents or in a measurement and calibration system. Tags: xml.sequenceOffset=210
display Presentation	DisplayPresentation Enum	0..1	attr	This attribute controls the presentation of the related data for measurement and calibration tools.
implementation DataType	AbstractImplementation DataType	0..1	ref	This association denotes the ImplementationDataType of a data declaration via its aggregated SwDataDefProps. It is used whenever a data declaration is not directly referring to a base type. Especially <ul style="list-style-type: none"> • redefinition of an ImplementationDataType via a "typedef" to another ImplementationDatatype • the target type of a pointer (see SwPointerTarget Props), if it does not refer to a base type directly • the data type of an array or record element within an ImplementationDataType, if it does not refer to a base type directly • the data type of an SwServiceArg, if it does not refer to a base type directly Tags: xml.sequenceOffset=215
invalidValue	ValueSpecification	0..1	aggr	Optional value to express invalidity of the actual data element. Tags: xml.sequenceOffset=255
stepSize	Float	0..1	attr	This attribute can be used to define a value which is added to or subtracted from the value of a DataPrototype when using up/down keys while calibrating.
swAddrMethod	SwAddrMethod	0..1	ref	Addressing method related to this data object. Via an association to the same SwAddrMethod it can be specified that several DataPrototypes shall be located in the same memory without already specifying the memory section itself. Tags: xml.sequenceOffset=30





Class	<<atpVariation>> SwDataDefProps			
swAlignment	AlignmentType	0..1	attr	The attribute describes the intended typical alignment of the DataPrototype. If the attribute is not defined the alignment is determined by the swBaseType size and the memoryAllocationKeywordPolicy of the referenced Sw AddrMethod. Tags: xml.sequenceOffset=33
swBit Representation	SwBitRepresentation	0..1	aggr	Description of the binary representation in case of a bit variable. Tags: xml.sequenceOffset=60
swCalibration Access	SwCalibrationAccess Enum	0..1	attr	Specifies the read or write access by MCD tools for this data object. Tags: xml.sequenceOffset=70
swCalprmAxis Set	SwCalprmAxisSet	0..1	aggr	This specifies the properties of the axes in case of a curve or map etc. This is mainly applicable to calibration parameters. Tags: xml.sequenceOffset=90
swComparison Variable	SwVariableRefProxy	*	aggr	Variables used for comparison in an MCD process. Tags: xml.sequenceOffset=170 xml.typeElement=false
swData Dependency	SwDataDependency	0..1	aggr	Describes how the value of the data object has to be calculated from the value of another data object (by the MCD system). Tags: xml.sequenceOffset=200
swHostVariable	SwVariableRefProxy	0..1	aggr	Contains a reference to a variable which serves as a host-variable for a bit variable. Only applicable to bit objects. Tags: xml.sequenceOffset=220 xml.typeElement=false
swImplPolicy	SwImplPolicyEnum	0..1	attr	Implementation policy for this data object. Tags: xml.sequenceOffset=230
swIntended Resolution	Numerical	0..1	attr	The purpose of this element is to describe the requested quantization of data objects early on in the design process. The resolution ultimately occurs via the conversion formula present (compuMethod), which specifies the transition from the physical world to the standardized world (and vice-versa) (here, "the slope per bit" is present implicitly in the conversion formula). In the case of a development phase without a fixed conversion formula, a pre-specification can occur through swIntendedResolution. The resolution is specified in the physical domain according to the property "unit". Tags: xml.sequenceOffset=240
swInterpolation Method	Identifier	0..1	attr	This is a keyword identifying the mathematical method to be applied for interpolation. The keyword needs to be related to the interpolation routine which needs to be invoked. Tags: xml.sequenceOffset=250





Class	<<atpVariation>> SwDataDefProps			
swIsVirtual	Boolean	0..1	attr	This element distinguishes virtual objects. Virtual objects do not appear in the memory, their derivation is much more dependent on other objects and hence they shall have a swDataDependency . Tags: xml.sequenceOffset=260
swPointerTarget Props	SwPointerTargetProps	0..1	aggr	Specifies that the containing data object is a pointer to another data object. Tags: xml.sequenceOffset=280
swRecord Layout	SwRecordLayout	0..1	ref	Record layout for this data object. Tags: xml.sequenceOffset=290
swRefresh Timing	MultidimensionalTime	0..1	aggr	This element specifies the frequency in which the object involved shall be or is called or calculated. This timing can be collected from the task in which write access processes to the variable run. But this cannot be done by the MCD system. So this attribute can be used in an early phase to express the desired refresh timing and later on to specify the real refresh timing. Tags: xml.sequenceOffset=300
swTextProps	SwTextProps	0..1	aggr	the specific properties if the data object is a text object. Tags: xml.sequenceOffset=120
swValueBlock Size	Numerical	0..1	attr	This represents the size of a Value Block Stereotypes: atpVariation Tags: vh.latestBindingTime=preCompileTime xml.sequenceOffset=80
swValueBlock SizeMult (ordered)	Numerical	*	attr	This attribute is used to specify the dimensions of a value block (VAL_BLK) for the case that that value block has more than one dimension. The dimensions given in this attribute are ordered such that the first entry represents the first dimension, the second entry represents the second dimension, and so on. For one-dimensional value blocks the attribute swValueBlockSize shall be used and this attribute shall not exist. Stereotypes: atpVariation Tags: vh.latestBindingTime=preCompileTime
unit	Unit	0..1	ref	Physical unit associated with the semantics of this data object. This attribute applies if no compuMethod is specified. If both units (this as well as via compuMethod) are specified the units shall be compatible. Tags: xml.sequenceOffset=350
valueAxisData Type	ApplicationPrimitive DataType	0..1	ref	The referenced ApplicationPrimitiveDataType represents the primitive data type of the value axis within a compound primitive (e.g. curve, map). It supersedes CompuMethod, Unit, and BaseType. Tags: xml.sequenceOffset=355

Table B.127: SwDataDefProps

Enumeration	SwImplPolicyEnum
Package	M2::MSR::DataDictionary::DataDefProperties
Note	Specifies the implementation strategy with respect to consistency mechanisms of variables.
Aggregated by	BswInternalTriggeringPoint.swImplPolicy, InternalTriggeringPoint.swImplPolicy, SwDataDefProps.swImplPolicy , Trigger.swImplPolicy
Literal	Description
const	forced implementation such that the running software within the ECU shall not modify it. For example implemented with the "const" modifier in C. This can be applied for parameters (not for those in NVRAM) as well as argument data prototypes. Tags: atp.EnumerationLiteralIndex=0
fixed	This data element is fixed. In particular this indicates, that it might also be implemented e.g. as in place data, (#DEFINE). Tags: atp.EnumerationLiteralIndex=1
measurementPoint	The data element is created for measurement purposes only. The data element is never read directly within the ECU software. In contrast to a "standard" data element in an unconnected provide port is, this unconnection is guaranteed for measurementPoint data elements. Tags: atp.EnumerationLiteralIndex=2
queued	The content of the data element is queued and the data element has 'event' semantics, i.e. data elements are stored in a queue and all data elements are processed in 'first in first out' order. The queuing is intended to be implemented by RTE Generator. This value is not applicable for parameters. Tags: atp.EnumerationLiteralIndex=3
standard	This is applicable for all kinds of data elements. For variable data prototypes the 'last is best' semantics applies. For parameter there is no specific implementation directive. Tags: atp.EnumerationLiteralIndex=4

Table B.128: SwImplPolicyEnum

Class	SwRecordLayout			
Package	M2::MSR::DataDictionary::RecordLayout			
Note	Defines how the data objects (variables, calibration parameters etc.) are to be stored in the ECU memory. As an example, this definition specifies the sequence of axis points in the ECU memory. Iterations through axis values are stored within the sub-elements swRecordLayoutGroup. Tags: atp.recommendedPackage=SwRecordLayouts			
Base	ARElement , ARObject , CollectableElement , Identifiable , MultilanguageReferrable , PackageableElement , Referrable			
Aggregated by	ARPackage.element			
Attribute	Type	Mult.	Kind	Note
swRecordLayoutGroup	SwRecordLayoutGroup	0..1	aggr	This is the top level record layout group. Tags: xml.roleElement=true xml.roleWrapperElement=false xml.sequenceOffset=20 xml.typeElement=false xml.typeWrapperElement=false

Table B.129: SwRecordLayout

Class	SwcModeSwitchEvent
Package	M2::AUTOSARTemplates::SWComponentTemplate::SwcInternalBehavior::RTEEvents
Note	This event is raised when the specified mode change occurs.
Base	ARObject , AbstractEvent , AtpClassifier , AtpFeature , AtpStructureElement , Identifiable , MultilanguageReferrable , RTEEvent , Referrable





Class	SwcModeSwitchEvent			
Aggregated by	AtpClassifier.atpFeature, SwcInternalBehavior.event			
Attribute	Type	Mult.	Kind	Note
activation	ModeActivationKind	0..1	attr	Specifies if the event is raised on entering or exiting a specific mode or is raised on the transition between two modes.
mode (ordered)	ModeDeclaration	0..2	iref	The referenced mode or the transition between two modes raises this SwcModeSwitchEvent. InstanceRef implemented by: RModelInAtomicSwc InstanceRef

Table B.130: SwcModeSwitchEvent

Class	SynchronousServerCallPoint			
Package	M2::AUTOSARTemplates::SWComponentTemplate::SwcInternalBehavior::ServerCall			
Note	This means that the RunnableEntity is supposed to perform a blocking wait for a response from the server.			
Base	ARObject, AbstractAccessPoint , AtpClassifier, AtpFeature, AtpStructureElement, Identifiable , MultilanguageReferrable , Referrable , ServerCallPoint			
Aggregated by	AtpClassifier.atpFeature, RunnableEntity.serverCallPoint			
Attribute	Type	Mult.	Kind	Note
calledFrom WithinExclusive Area	ExclusiveAreaNesting Order	0..1	ref	This indicates that the call point is located at the deepest level inside one or more ExclusiveAreas that are nested in the given order.

Table B.131: SynchronousServerCallPoint

Class	System			
Package	M2::AUTOSARTemplates::SystemTemplate			
Note	<p>The top level element of the System Description. The System description defines five major elements: Topology, Software, Communication, Mapping and Mapping Constraints.</p> <p>The System element directly aggregates the elements describing the Software, Mapping and Mapping Constraints; it contains a reference to an ASAM FIBEX description specifying Communication and Topology.</p> <p>Tags:atp.recommendedPackage=Systems</p>			
Base	ARElement, ARObject, AtpClassifier, AtpFeature, AtpStructureElement, CollectableElement , Identifiable , MultilanguageReferrable , PackageableElement , Referrable			
Aggregated by	ARPackage.element, AtpClassifier.atpFeature			
Attribute	Type	Mult.	Kind	Note
clientId DefinitionSet	ClientIdDefinitionSet	*	ref	Set of Client Identifiers that are used for inter-ECU client-server communication in the System.
containerIPdu HeaderByte Order	ByteOrderEnum	0..1	attr	Defines the byteOrder of the header in ContainerIPdus.
ecuExtract Version	RevisionLabelString	0..1	attr	Version number of the Ecu Extract.





Class	System			
fibexElement	FibexElement	*	ref	<p>Reference to ASAM FIBEX elements specifying Communication and Topology.</p> <p>All Fibex Elements used within a System Description shall be referenced from the System Element.</p> <p>atpVariation: In order to describe a product-line, all Fibex Elements can be optional.</p> <p>Stereotypes: atpSplittable; atpVariation Tags: atp.Splitkey=fibexElement.fibexElement, fibexElement.variationPoint.shortLabel vh.latestBindingTime=postBuild</p>
interpolationRoutineMappingSet	InterpolationRoutineMappingSet	*	ref	<p>This reference identifies the InterpolationRoutineMapping Sets that are relevant in the context of the enclosing System.</p>
j1939SharedAddressCluster	J1939SharedAddressCluster	*	aggr	<p>Collection of J1939Clusters that share a common address space for the routing of messages.</p> <p>Stereotypes: atpSplittable; atpVariation Tags: atp.Splitkey=j1939SharedAddressCluster.shortName, j1939SharedAddressCluster.variationPoint.shortLabel vh.latestBindingTime=postBuild</p>
mapping	SystemMapping	*	aggr	<p>Aggregation of all mapping aspects (mapping of SW components to ECUs, mapping of data elements to signals, and mapping constraints).</p> <p>In order to support OEM / Tier 1 interaction and shared development for one common System this aggregation is atpSplittable and atpVariation. The content of System Mapping can be provided by several parties using different names for the SystemMapping.</p> <p>This element is not required when the System description is used for a network-only use-case.</p> <p>Stereotypes: atpSplittable; atpVariation Tags: atp.Splitkey=mapping.shortName, mapping.variationPoint.shortLabel vh.latestBindingTime=postBuild</p>
pncVectorLength	PositiveInteger	0..1	attr	<p>Length of the partial networking request release information vector (in bytes).</p>
pncVectorOffset	PositiveInteger	0..1	attr	<p>Absolute offset (with respect to the NM-PDU) of the partial networking request release information vector that is defined in bytes as an index starting with 0.</p>
rootSoftwareComposition	RootSwCompositionPrototype	0..1	aggr	<p>Aggregation of the root software composition, containing all software components in the System in a hierarchical structure. This element is not required when the System description is used for a network-only use-case.</p> <p>atpVariation: The RootSwCompositionPrototype can vary.</p> <p>Stereotypes: atpSplittable; atpVariation Tags: atp.Splitkey=rootSoftwareComposition.shortName, rootSoftwareComposition.variationPoint.shortLabel vh.latestBindingTime=systemDesignTime</p>





Class	System			
swCluster	CpSoftwareCluster	*	ref	CP Software Clusters of this System Stereotypes: atpSplitable; atpVariation Tags: atp.Splitkey=swCluster.cpSoftwareCluster, swCluster.variationPoint.shortLabel atp.Status=draft vh.latestBindingTime=systemDesignTime
systemDocumentation	Chapter	*	aggr	Possibility to provide additional documentation while defining the System. The System documentation can be composed of several chapters. Stereotypes: atpSplitable; atpVariation Tags: atp.Splitkey=systemDocumentation.shortName, systemDocumentation.variationPoint.shortLabel vh.latestBindingTime=systemDesignTime xml.sequenceOffset=-10
systemVersion	RevisionLabelString	1	attr	Version number of the System Description.

Table B.132: System

Class	TimingEvent			
Package	M2::AUTOSARTemplates::SWComponentTemplate::SwcInternalBehavior::RTEEvents			
Note	This event is used to start RunnableEntities that shall be executed periodically.			
Base	<i>ARObject, AbstractEvent, AtpClassifier, AtpFeature, AtpStructureElement, Identifiable, MultilanguageReferrable, RTEEvent, Referrable</i>			
Aggregated by	<i>AtpClassifier.atpFeature, SwcInternalBehavior.event</i>			
Attribute	Type	Mult.	Kind	Note
offset	TimeValue	0..1	attr	The value makes an assumption about the time offset of the first activation of the RunnableEntity triggered by the mapped TimingEvent relative to the periodic activation of the time base of this TimingEvent. Unit: second.
period	TimeValue	0..1	attr	Period of timing event in seconds. The value of this attribute shall be greater than zero.

Table B.133: TimingEvent

Class	Trigger			
Package	M2::AUTOSARTemplates::CommonStructure::TriggerDeclaration			
Note	A trigger which is provided (i.e. released) or required (i.e. used to activate something) in the given context.			
Base	<i>ARObject, AtpClassifier, AtpFeature, AtpStructureElement, Identifiable, MultilanguageReferrable, Referrable</i>			
Aggregated by	<i>AtpClassifier.atpFeature, BswModuleDescription.releasedTrigger, BswModuleDescription.requiredTrigger, ServiceInterface.trigger, TriggerInterface.trigger</i>			
Attribute	Type	Mult.	Kind	Note
swImplPolicy	SwImplPolicyEnum	0..1	attr	This attribute, when set to value queued, allows for a queued processing of Triggers.
triggerPeriod	MultidimensionalTime	0..1	aggr	Optional definition of a period in case of a periodically (time or angle) driven external trigger.

Table B.134: Trigger

Class	TriggerInterface			
Package	M2::AUTOSARTemplates::SWComponentTemplate::PortInterface			
Note	A trigger interface declares a number of triggers that can be sent by an trigger source. Tags: atp.recommendedPackage=PortInterfaces			
Base	<i>ARElement, ARObject, AtpBlueprint, AtpBlueprintable, AtpClassifier, AtpType, CollectableElement, Identifiable, MultilanguageReferrable, PackageableElement, PortInterface, Referrable</i>			
Aggregated by	ARPackage.element			
Attribute	Type	Mult.	Kind	Note
trigger	Trigger	*	aggr	The Trigger of this trigger interface.

Table B.135: TriggerInterface

Class	Unit			
Package	M2::MSR::AsamHdo::Units			
Note	<p>This is a physical measurement unit. All units that might be defined should stem from SI units. In order to convert one unit into another factor and offset are defined.</p> <p>For the calculation from SI-unit to the defined unit the factor (factorSiToUnit) and the offset (offsetSiToUnit) are applied as follows:</p> $x \{unit\} := y * \{siUnit\} * factorSiToUnit \{unit\} / \{siUnit\} + offsetSiToUnit \{unit\}$ <p>For the calculation from a unit to SI-unit the reciprocal of the factor (factorSiToUnit) and the negation of the offset (offsetSiToUnit) are applied.</p> $y \{siUnit\} := (x * \{unit\} - offsetSiToUnit \{unit\}) / (factorSiToUnit \{unit\} / \{siUnit\})$ <p>Tags:atp.recommendedPackage=Units</p>			
Base	<i>ARElement, ARObject, CollectableElement, Identifiable, MultilanguageReferrable, PackageableElement, Referrable</i>			
Aggregated by	ARPackage.element			
Attribute	Type	Mult.	Kind	Note
displayName	SingleLanguageUnit Names	0..1	aggr	This specifies how the unit shall be displayed in documents or in user interfaces of tools.The displayName corresponds to the Unit.Display in an ASAM MCD-2MC file. Tags: xml.sequenceOffset=20
factorSiToUnit	Float	0..1	attr	This is the factor for the conversion from SI Units to units. The inverse is used for conversion from units to SI Units. Tags: xml.sequenceOffset=30
offsetSiToUnit	Float	0..1	attr	This is the offset for the conversion from and to siUnits. Tags: xml.sequenceOffset=40
physical Dimension	PhysicalDimension	0..1	ref	This association represents the physical dimension to which the unit belongs to. Note that only values with units of the same physical dimensions might be converted. Tags: xml.sequenceOffset=50

Table B.136: Unit

Class	VariableAccess			
Package	M2::AUTOSARTemplates::SWComponentTemplate::SwcInternalBehavior::DataElements			
Note	<p>The presence of a VariableAccess implies that a RunnableEntity needs access to a VariableData Prototype.</p> <p>The kind of access is specified by the role in which the class is used.</p>			





Class	VariableAccess			
Base	<i>ARObject</i> , AbstractAccessPoint , <i>AtpClassifier</i> , <i>AtpFeature</i> , <i>AtpStructureElement</i> , Identifiable , MultilanguageReferrable , Referrable			
Aggregated by	<i>AtpClassifier.atpFeature</i> , <i>ReceiverComSpec.replaceWith</i> , RunnableEntity.dataReadAccess , RunnableEntity.dataReceivePointByArgument , RunnableEntity.dataReceivePointByValue , RunnableEntity.dataSendPoint , RunnableEntity.dataWriteAccess , RunnableEntity.readLocalVariable , RunnableEntity.writtenLocalVariable			
Attribute	Type	Mult.	Kind	Note
accessed Variable	AutosarVariableRef	0..1	aggr	This denotes the accessed variable.
scope	VariableAccessScope Enum	0..1	attr	This attribute allows for constraining the scope of the corresponding communication. For example, it possible to express whether the communication is intended to cross the boundary of an ECU or whether it is intended not to cross the boundary of a single partition.

Table B.137: VariableAccess

Class	VariableDataPrototype			
Package	M2::AUTOSARTemplates::SWComponentTemplate::Datatype::DataPrototypes			
Note	A VariableDataPrototype represents a formalized generic piece of information that is typically mutable by the application software layer. VariableDataPrototype is used in various contexts and the specific context gives the otherwise generic VariableDataPrototype a dedicated semantics.			
Base	<i>ARObject</i> , <i>AtpFeature</i> , <i>AtpPrototype</i> , AutosarDataPrototype , DataPrototype , Identifiable , MultilanguageReferrable , Referrable			
Aggregated by	ApplicationInterface.indication, <i>AtpClassifier.atpFeature</i> , BswInternalBehavior.arTypedPerInstanceMemory, BswModuleDescription.providedData , BswModuleDescription.requiredData , BulkNvDataDescriptor.bulkNvBlock, InternalBehavior.staticMemory , NvBlockDescriptor.ramBlock, NvDataInterface.nvData , SenderReceiverInterface.dataElement , ServiceInterface.event, SwcInternalBehavior.arTypedPerInstanceMemory, SwcInternalBehavior.explicitInterRunnableVariable, SwcInternalBehavior.implicitInterRunnableVariable			
Attribute	Type	Mult.	Kind	Note
initValue	ValueSpecification	0..1	aggr	Specifies initial value(s) of the VariableDataPrototype

Table B.138: VariableDataPrototype

C Referenced ECUC Configuration Parameters

C.1 EcuC

C.1.1 EcucPartition

SWS Item	[ECUC_EcuC_00005]		
Container Name	EcucPartition		
Parent Container	EcucPartitionCollection		
Description	Definition of one Partition on this ECU. One Partition will be implemented using one Os-Application.		
Post-Build Variant Multiplicity	false		
Multiplicity Configuration Class	Pre-compile time	X	VARIANT-PRE-COMPILE, VARIANT-POST-BUILD
	Link time	–	
	Post-build time	–	
Configuration Parameters			

SWS Item	[ECUC_EcuC_00037]		
Parameter Name	EcucDefaultBswPartition		
Parent Container	EcucPartition		
Description	Denotes the default BSW partition. This partition will host all BSW Modules, which are not explicitly mapped to a different partition. For partitions other than the default BSW partition this parameter can be omitted.		
Multiplicity	0..1		
Type	EcucBooleanParamDef		
Default value	–		
Post-Build Variant Multiplicity	false		
Post-Build Variant Value	false		
Multiplicity Configuration Class	Pre-compile time	X	All Variants
	Link time	–	
	Post-build time	–	
Value Configuration Class	Pre-compile time	X	All Variants
	Link time	–	
	Post-build time	–	
Scope / Dependency			

SWS Item	[ECUC_EcuC_00006]		
Parameter Name	PartitionCanBeRestarted		
Parent Container	EcucPartition		
Description	Specifies the requirement whether the Partition can be restarted. If set to true all software executing in this partition shall be capable of handling a restart.		
Multiplicity	1		
Type	EcucBooleanParamDef		
Default value	–		
Post-Build Variant Value	false		
Value Configuration Class	Pre-compile time	X	All Variants
	Link time	–	





	Post-build time	-	
Scope / Dependency			

SWS Item	[ECUC_EcuC_00083]		
Parameter Name	EcuEcuPartitionRef		
Parent Container	EcuPartition		
Description	Reference to the EcuPartition to define the link to the partition described in the System description. Tags: atp.Status=draft		
Multiplicity	0..1		
Type	Foreign reference to ECU-PARTITION		
Multiplicity Configuration Class	Pre-compile time	X	All Variants
	Link time	-	
	Post-build time	-	
Value Configuration Class	Pre-compile time	X	All Variants
	Link time	-	
	Post-build time	-	
Scope / Dependency	scope: ECU		

SWS Item	[ECUC_EcuC_00068]		
Parameter Name	EcuPartitionBswModuleDistinguishedPartition		
Parent Container	EcuPartition		
Description	This maps the abstract partition of the Bsw Module to a concrete Partition existing in the ECU.		
Multiplicity	0..*		
Type	Foreign reference to BSW-DISTINGUISHED-PARTITION		
Post-Build Variant Multiplicity	false		
Post-Build Variant Value	false		
Multiplicity Configuration Class	Pre-compile time	X	All Variants
	Link time	-	
	Post-build time	-	
Value Configuration Class	Pre-compile time	X	All Variants
	Link time	-	
	Post-build time	-	
Scope / Dependency			

SWS Item	[ECUC_EcuC_00036]		
Parameter Name	EcuPartitionSoftwareComponentInstanceRef		
Parent Container	EcuPartition		
Description	References the SW Component instances from the Ecu Extract that shall be executed in this partition.		
Multiplicity	0..*		
Type	Instance reference to SW-COMPONENT-PROTOTYPE context: ROOT-SW-COMPOSITION-PROTOTYPE		
Post-Build Variant Multiplicity	false		
Post-Build Variant Value	false		
Multiplicity Configuration Class	Pre-compile time	X	All Variants
	Link time	-	





	Post-build time	–	
Value Configuration Class	Pre-compile time	X	All Variants
	Link time	–	
	Post-build time	–	
Scope / Dependency			

No Included Containers

C.1.2 Pdu

SWS Item	[ECUC_EcuC_00001]		
Container Name	Pdu		
Parent Container	EcuC_PduCollection		
Description	One Pdu flowing through the COM-Stack. This Pdu is used by all Com-Stack modules to agree on referencing the same Pdu.		
Post-Build Variant Multiplicity	true		
Multiplicity Configuration Class	Pre-compile time	X	VARIANT-PRE-COMPILE
	Link time	–	
	Post-build time	X	VARIANT-POST-BUILD
Configuration Parameters			

SWS Item	[ECUC_EcuC_00078]		
Parameter Name	DynamicLength		
Parent Container	Pdu		
Description	This parameter defines whether the Pdu has dynamic length (true) or not (false). Please note that the usage of this attribute is restricted by [constr_3448].		
Multiplicity	0..1		
Type	EcuC_BooleanParamDef		
Default value	–		
Post-Build Variant Multiplicity	true		
Post-Build Variant Value	true		
Multiplicity Configuration Class	Pre-compile time	X	VARIANT-PRE-COMPILE
	Link time	–	
	Post-build time	X	VARIANT-POST-BUILD
Value Configuration Class	Pre-compile time	X	VARIANT-PRE-COMPILE
	Link time	–	
	Post-build time	X	VARIANT-POST-BUILD
Scope / Dependency			

SWS Item	[ECUC_EcuC_00072]		
Parameter Name	J1939Requestable		
Parent Container	Pdu		
Description	Pdu can be triggered by the J1939 request message.		
Multiplicity	0..1		
Type	EcuC_BooleanParamDef		





Default value	–		
Post-Build Variant Multiplicity	true		
Post-Build Variant Value	true		
Multiplicity Configuration Class	Pre-compile time	X	VARIANT-PRE-COMPILE
	Link time	–	
	Post-build time	X	VARIANT-POST-BUILD
Value Configuration Class	Pre-compile time	X	VARIANT-PRE-COMPILE
	Link time	–	
	Post-build time	X	VARIANT-POST-BUILD
Scope / Dependency			

SWS Item	[ECUC_EcuC_00003]		
Parameter Name	PduLength		
Parent Container	Pdu		
Description	Length of the Pdu in bytes. It should be noted that in former AUTOSAR releases (Rel 2.1, Rel 3.0, Rel 3.1, Rel 4.0 Rev. 1) this parameter was defined in bits.		
Multiplicity	1		
Type	EcucIntegerParamDef		
Range	0 .. 4294967295		
Default value	–		
Post-Build Variant Value	true		
Value Configuration Class	Pre-compile time	X	VARIANT-PRE-COMPILE
	Link time	–	
	Post-build time	X	VARIANT-POST-BUILD
Scope / Dependency			

SWS Item	[ECUC_EcuC_00082]		
Parameter Name	EcucPduDefaultPartitionRef		
Parent Container	Pdu		
Description	Reference to EcucPartition, where the according Pdu is assigned to.		
Multiplicity	0..1		
Type	Reference to EcucPartition		
Post-Build Variant Multiplicity	false		
Post-Build Variant Value	false		
Multiplicity Configuration Class	Pre-compile time	X	All Variants
	Link time	–	
	Post-build time	–	
Value Configuration Class	Pre-compile time	X	All Variants
	Link time	–	
	Post-build time	–	
Scope / Dependency	scope: local		

SWS Item	[ECUC_EcuC_00077]		
Parameter Name	MetaDataTypeRef		
Parent Container	Pdu		
Description	Reference to meta data that is transported in the Pdu through the AUTOSAR layers.		
Multiplicity	0..1		





Type	Reference to MetaDataType		
Post-Build Variant Value	false		
Value Configuration Class	Pre-compile time	X	All Variants
	Link time	–	
	Post-build time	–	
Scope / Dependency			

SWS Item	[ECUC_EcuC_00052]		
Parameter Name	SysTPduToFrameTriggeringRef		
Parent Container	Pdu		
Description	Reference to the FrameTriggering from the SystemTemplate which this Pdu belongs to. SysTPduToFrameTriggeringRef shall be used for UserDefinedPdus, NmPdus and NPdus which are not going through the Pdu Router. This reference shall not be used if SysTPduToPduTriggeringRef exists.		
Multiplicity	0..1		
Type	Foreign reference to FRAME-TRIGGERING		
Post-Build Variant Multiplicity	true		
Post-Build Variant Value	true		
Multiplicity Configuration Class	Pre-compile time	X	VARIANT-PRE-COMPILE
	Link time	–	
	Post-build time	X	VARIANT-POST-BUILD
Value Configuration Class	Pre-compile time	X	VARIANT-PRE-COMPILE
	Link time	–	
	Post-build time	X	VARIANT-POST-BUILD
Scope / Dependency	dependency: SysTPduToFrameTriggeringRef shall be used for UserDefinedPdus, NmPdus and NPdus which are not going through the Pdu Router. This reference shall not be used if SysTPduToPduTriggeringRef exists.		

SWS Item	[ECUC_EcuC_00054]		
Parameter Name	SysTPduToPduTriggeringRef		
Parent Container	Pdu		
Description	Reference to the PduTriggering from the SystemTemplate which this Pdu represents. SysTPduToPduTriggeringRef shall be used for all Pdus except UserDefinedPdus, NmPdus and NPdus which are not going through the Pdu Router. For these Pdus, SysTPduToFrameTriggeringRef shall be used.		
Multiplicity	0..1		
Type	Foreign reference to PDU-TRIGGERING		
Post-Build Variant Multiplicity	true		
Post-Build Variant Value	true		
Multiplicity Configuration Class	Pre-compile time	X	VARIANT-PRE-COMPILE
	Link time	–	
	Post-build time	X	VARIANT-POST-BUILD
Value Configuration Class	Pre-compile time	X	VARIANT-PRE-COMPILE
	Link time	–	
	Post-build time	X	VARIANT-POST-BUILD
Scope / Dependency	dependency: SysTPduToPduTriggeringRef shall be used for all Pdus except User DefinedPdus, NmPdus and NPdus which are not going through the Pdu Router. This reference shall not be used if SysTPduToFrameTriggeringRef exists.		

Included Containers		
Container Name	Multiplicity	Scope / Dependency
EcucPduDedicatedPartition	0..*	Module specific container for Pdu to partition assignment.

C.1.3 EcucPduDedicatedPartition

SWS Item	[ECUC_EcuC_00079]		
Container Name	EcucPduDedicatedPartition		
Parent Container	Pdu		
Description	Module specific container for Pdu to partition assignment.		
Post-Build Variant Multiplicity	true		
Multiplicity Configuration Class	Pre-compile time	X	All Variants
	Link time	–	
	Post-build time	–	
Configuration Parameters			

SWS Item	[ECUC_EcuC_00080]		
Parameter Name	EcucPduDedicatedPartitionBswModuleRef		
Parent Container	EcucPduDedicatedPartition		
Description	Reference to BSW module, for which the according dedicated Pdu assignment is valid.		
Multiplicity	1		
Type	Foreign reference to ECUC-MODULE-CONFIGURATION-VALUES		
Post-Build Variant Value	false		
Value Configuration Class	Pre-compile time	X	All Variants
	Link time	–	
	Post-build time	–	
Scope / Dependency	scope: local		

SWS Item	[ECUC_EcuC_00081]		
Parameter Name	EcucPduDedicatedPartitionRef		
Parent Container	EcucPduDedicatedPartition		
Description	Module specific reference to EcucPartition, where the according Pdu is assigned to. The dedicated partition reference shall overrule the default partition reference for the respective module.		
Multiplicity	1		
Type	Reference to EcucPartition		
Post-Build Variant Value	false		
Value Configuration Class	Pre-compile time	X	All Variants
	Link time	–	
	Post-build time	–	
Scope / Dependency	scope: local		

No Included Containers

C.2 RTE

C.2.1 RteEventToTaskMapping

SWS Item	[ECUC_Rte_09020]
Container Name	RteEventToTaskMapping
Parent Container	RteSwComponentInstance
Description	Maps an instance of a RunnableEntity onto one OsTask based on the activating RTEEvent. In the case of a RunnableEntity executed via a direct or trusted function call this RteEventToTaskMapping is still specified but no RteMappedToTask element is included. The RtePositionInTask parameter is necessary to provide an ordering of events invoked by the same RTE API.
Configuration Parameters	

SWS Item	[ECUC_Rte_09018]		
Parameter Name	RteActivationOffset		
Parent Container	RteEventToTaskMapping		
Description	Activation offset in seconds.		
Multiplicity	0..1		
Type	EcucFloatParamDef		
Range	[0 .. INF]		
Default value	-		
Post-Build Variant Multiplicity	false		
Post-Build Variant Value	false		
Multiplicity Configuration Class	Pre-compile time	X	All Variants
	Link time	-	
	Post-build time	-	
Value Configuration Class	Pre-compile time	X	All Variants
	Link time	-	
	Post-build time	-	
Scope / Dependency	scope: local		

SWS Item	[ECUC_Rte_09092]		
Parameter Name	RteImmediateRestart		
Parent Container	RteEventToTaskMapping		
Description	<p>When RteImmediateRestart is set to true the RunnableEntity shall be immediately re-started after termination if it was activated by this RTEEvent while it was already started.</p> <p>This parameter shall not be set to true when the mapped RTEEvent refers to a RunnableEntity which minimumStartInterval attribute is > 0.</p>		
Multiplicity	1		
Type	EcucBooleanParamDef		
Default value	false		
Post-Build Variant Value	false		
Value Configuration Class	Pre-compile time	X	All Variants
	Link time	-	
	Post-build time	-	
Scope / Dependency	scope: local		

SWS Item	[ECUC_Rte_09022]		
Parameter Name	RteOsSchedulePoint		
Parent Container	RteEventToTaskMapping		
Description	<p>Introduce a schedule point by explicitly calling Os Schedule service after the execution of the ExecutableEntity. The Rte generator is allowed to optimize several consecutive calls to Os schedule into one single call if the ExecutableEntity executions in between have been skipped.</p> <p>The absence of this parameter is interpreted as "NONE".</p> <p>It shall be considered an invalid configuration if the task is preemptable and the value of this parameter is not set to "NONE" or the parameter is absent.</p>		
Multiplicity	0..1		
Type	EcucEnumerationParamDef		
Range	CONDITIONAL	A Schedule Point shall be introduced at the end of the execution of this ExecutableEntity. The Schedule Point can be skipped if several Schedule Points would be called without any ExecutableEntity execution in between.	
	NONE	No Schedule Point shall be introduced at the end of the execution of this ExecutableEntity.	
	UNCONDITIONAL	A Schedule Point shall always be introduced at the end of the execution of this ExecutableEntity.	
Post-Build Variant Multiplicity	false		
Post-Build Variant Value	false		
Multiplicity Configuration Class	Pre-compile time	X	All Variants
	Link time	–	
	Post-build time	–	
Value Configuration Class	Pre-compile time	X	All Variants
	Link time	–	
	Post-build time	–	
Scope / Dependency	scope: local		

SWS Item	[ECUC_Rte_09023]		
Parameter Name	RtePositionInTask		
Parent Container	RteEventToTaskMapping		
Description	<p>Each RunnableEntity mapped to an OsTask has a specific position within the task execution. For periodic activation this is the order of execution. For event driver activation this is the order of evaluation which actual RunnableEntity has to be executed. In case of direct or trusted function calls this parameter is necessary to provide an ordering of events when several ExecutableEntities are invoked by the same RTE API.</p>		
Multiplicity	0..1		
Type	EcucIntegerParamDef		
Range	0 .. 65535		
Default value	–		
Post-Build Variant Multiplicity	false		
Post-Build Variant Value	false		
Multiplicity Configuration Class	Pre-compile time	X	All Variants
	Link time	–	
	Post-build time	–	
Value Configuration Class	Pre-compile time	X	All Variants
	Link time	–	





	Post-build time	–	
Scope / Dependency	scope: local		

SWS Item	[ECUC_Rte_09214]		
Parameter Name	RteServerNumberOfRequestProcessing		
Parent Container	RteEventToTaskMapping		
Description	Specifies the maximum number of queued requests that can be handled within one Os Task execution.		
Multiplicity	0..1		
Type	EcucIntegerParamDef		
Range	1 .. 65535		
Default value	–		
Post-Build Variant Multiplicity	false		
Post-Build Variant Value	false		
Multiplicity Configuration Class	Pre-compile time	X	All Variants
	Link time	–	
	Post-build time	–	
Value Configuration Class	Pre-compile time	X	All Variants
	Link time	–	
	Post-build time	–	
Scope / Dependency	scope: local		

SWS Item	[ECUC_Rte_09133]		
Parameter Name	RteServerQueueLength		
Parent Container	RteEventToTaskMapping		
Description	Specifies the length of the queue for the server call serialization. This value overwrites the queueLength specified at the ServerComSpec.		
Multiplicity	0..1		
Type	EcucIntegerParamDef		
Range	0 .. 65535		
Default value	–		
Post-Build Variant Multiplicity	false		
Post-Build Variant Value	false		
Multiplicity Configuration Class	Pre-compile time	X	All Variants
	Link time	–	
	Post-build time	–	
Value Configuration Class	Pre-compile time	X	All Variants
	Link time	–	
	Post-build time	–	
Scope / Dependency	scope: local		

SWS Item	[ECUC_Rte_09128]		
Parameter Name	RteEventPredecessorSyncPointRef		
Parent Container	RteEventToTaskMapping		





Description	<p>The RteEventPredecessorSyncPointRef is necessary to provide a cross core synchronization in case of RteEvents triggered by the same event source but mapped to tasks belonging to different partitions on different cores.</p> <p>The synchronization point must be reached by all referencing RteEvents before the execution in all related tasks is continued.</p> <p>In case of RteEventPredecessorSyncPointRef the RunnableEntity activated by the mapped RteEvent is executed after the synchronization point is passed.</p>		
Multiplicity	0..1		
Type	Reference to RteSyncPoint		
Post-Build Variant Multiplicity	false		
Post-Build Variant Value	false		
Multiplicity Configuration Class	Pre-compile time	X	All Variants
	Link time	–	
	Post-build time	–	
Value Configuration Class	Pre-compile time	X	All Variants
	Link time	–	
	Post-build time	–	
Scope / Dependency	scope: local		

SWS Item	[ECUC_Rte_09019]		
Parameter Name	RteEventRef		
Parent Container	RteEventToTaskMapping		
Description	<p>Reference to the description of the RTEEvent which is pointing to the RunnableEntity being mapped. This allows a fine grained mapping of RunnableEntites based on the activating RTEEvent.</p>		
Multiplicity	1..*		
Type	Foreign reference to RTE-EVENT		
Post-Build Variant Value	false		
Value Configuration Class	Pre-compile time	X	All Variants
	Link time	–	
	Post-build time	–	
Scope / Dependency	scope: local		

SWS Item	[ECUC_Rte_09129]		
Parameter Name	RteEventSuccessorSyncPointRef		
Parent Container	RteEventToTaskMapping		
Description	<p>The RteEventSuccessorSyncPointRef is necessary to provide a cross core synchronization in case of RteEvents triggered by the same event source but mapped to tasks belonging to different partitions on different cores.</p> <p>The synchronization point must be reached by all referencing RteEvents before the execution in all related tasks is continued.</p> <p>In case of RteEventSuccessorSyncPointRef the RunnableEntity activated by the mapped RteEvent is executed before the synchronization point is entered.</p>		
Multiplicity	0..1		
Type	Reference to RteSyncPoint		
Post-Build Variant Multiplicity	false		
Post-Build Variant Value	false		
Multiplicity Configuration Class	Pre-compile time	X	All Variants
	Link time	–	





	Post-build time	–	
Value Configuration Class	Pre-compile time	X	All Variants
	Link time	–	
	Post-build time	–	
Scope / Dependency	scope: local		

SWS Item	[ECUC_Rte_09021]		
Parameter Name	RteMappedToTaskRef		
Parent Container	RteEventToTaskMapping		
Description	<p>Reference to the OsTask the RunnableEntity activated by the RteEventRef is mapped to.</p> <p>If no reference to the OsTask is specified the RunnableEntity shall be executed via a direct or trusted function call.</p> <p>The fact that no reference to an OsTask is specified for a RunnableEntity does not necessarily imply that every RTE generator has to support the implementation of this RunnableEntity as a direct or trusted function call. The standard set of use cases for direct or trusted function calls that has to be supported by every RTE generator is explicitly stated as requirements in this document. For further optimization RTE vendors are free to support additional scenarios of direct or trusted function call implementations that are not explicitly required in this document.</p>		
Multiplicity	0..1		
Type	Reference to OsTask		
Post-Build Variant Multiplicity	false		
Post-Build Variant Value	false		
Multiplicity Configuration Class	Pre-compile time	X	All Variants
	Link time	–	
	Post-build time	–	
Value Configuration Class	Pre-compile time	X	All Variants
	Link time	–	
	Post-build time	–	
Scope / Dependency	scope: local		

SWS Item	[ECUC_Rte_89005]		
Parameter Name	RteRipsFillRoutineRef		
Parent Container	RteEventToTaskMapping		
Description	<p>Reference to a Buffer-Fill Routine implemented by an RTE Implementation Plug-In. This routine gets invoked directly before the ExecutableEntity is started.</p> <p>Attributes: requiresIndex=true</p>		
Multiplicity	0..*		
Type	Reference to destinationUri RteRipsUriDefSet/RteRipsPluginFillFlushRoutine		
Post-Build Variant Multiplicity	false		
Post-Build Variant Value	false		
Multiplicity Configuration Class	Pre-compile time	X	All Variants
	Link time	–	
	Post-build time	–	
Value Configuration Class	Pre-compile time	X	All Variants
	Link time	–	
	Post-build time	–	
Scope / Dependency	scope: local		

SWS Item	[ECUC_Rte_89006]		
Parameter Name	RteRipsFlushRoutineRef		
Parent Container	RteEventToTaskMapping		
Description	Reference to a Buffer-Flush Routine implemented by an RTE Implementation Plug-In. This routine gets invoked directly after the ExecutableEntity has terminated. Attributes: requiresIndex=true		
Multiplicity	0..*		
Type	Reference to destinationUri RteRipsUriDefSet/RteRipsPluginFillFlushRoutine		
Post-Build Variant Multiplicity	false		
Post-Build Variant Value	false		
Multiplicity Configuration Class	Pre-compile time	X	All Variants
	Link time	–	
	Post-build time	–	
Value Configuration Class	Pre-compile time	X	All Variants
	Link time	–	
	Post-build time	–	
Scope / Dependency	scope: local		

SWS Item	[ECUC_Rte_89008]		
Parameter Name	RteRipsInvocationHandlerRef		
Parent Container	RteEventToTaskMapping		
Description	Reference to a Buffer-Fill Routine implemented by an RTE Implementation Plug-In. This routine gets invoked directly before the ExecutableEntity is started.		
Multiplicity	0..1		
Type	Reference to destinationUri RteRipsUriDefSet/RteRipsInvocationHandler		
Post-Build Variant Multiplicity	false		
Post-Build Variant Value	false		
Multiplicity Configuration Class	Pre-compile time	X	All Variants
	Link time	–	
	Post-build time	–	
Value Configuration Class	Pre-compile time	X	All Variants
	Link time	–	
	Post-build time	–	
Scope / Dependency	scope: local		

SWS Item	[ECUC_Rte_09116]		
Parameter Name	RteUsedInitFnc		
Parent Container	RteEventToTaskMapping		
Description	The RunnableEntity is executed during initialization in the context of the Rte_Init_<Init Container> function.		
Multiplicity	0..1		
Type	Reference to RteInitializationRunnableBatch		
Post-Build Variant Multiplicity	false		
Post-Build Variant Value	false		
Multiplicity Configuration Class	Pre-compile time	X	All Variants
	Link time	–	
	Post-build time	–	
Value Configuration Class	Pre-compile time	X	All Variants





	Link time	–	
	Post-build time	–	
Scope / Dependency	scope: local		

SWS Item	[ECUC_Rte_09024]		
Parameter Name	RteUsedOsAlarmRef		
Parent Container	RteEventToTaskMapping		
Description	If an OsAlarm is used to activate the OsTask this RteEvent is mapped to it shall be referenced here.		
Multiplicity	0..1		
Type	Reference to OsAlarm		
Post-Build Variant Multiplicity	false		
Post-Build Variant Value	false		
Multiplicity Configuration Class	Pre-compile time	X	All Variants
	Link time	–	
	Post-build time	–	
Value Configuration Class	Pre-compile time	X	All Variants
	Link time	–	
	Post-build time	–	
Scope / Dependency	scope: local		

SWS Item	[ECUC_Rte_09025]		
Parameter Name	RteUsedOsEventRef		
Parent Container	RteEventToTaskMapping		
Description	If an OsEvent is used to activate the OsTask this RteEvent is mapped to it shall be referenced here.		
Multiplicity	0..1		
Type	Reference to OsEvent		
Post-Build Variant Multiplicity	false		
Post-Build Variant Value	false		
Multiplicity Configuration Class	Pre-compile time	X	All Variants
	Link time	–	
	Post-build time	–	
Value Configuration Class	Pre-compile time	X	All Variants
	Link time	–	
	Post-build time	–	
Scope / Dependency	scope: local		

SWS Item	[ECUC_Rte_09026]		
Parameter Name	RteUsedOsSchTblExpiryPointRef		
Parent Container	RteEventToTaskMapping		
Description	If an OsScheduleTableExpiryPoint is used to activate the OsTask this RteEvent is mapped to it shall be referenced here.		
Multiplicity	0..1		
Type	Reference to OsScheduleTableExpiryPoint		
Post-Build Variant Multiplicity	false		
Post-Build Variant Value	false		





Multiplicity Configuration Class	Pre-compile time	X	All Variants
	Link time	–	
	Post-build time	–	
Value Configuration Class	Pre-compile time	X	All Variants
	Link time	–	
	Post-build time	–	
Scope / Dependency	scope: local		

SWS Item	[ECUC_Rte_09027]		
Parameter Name	RteVirtuallyMappedToTaskRef		
Parent Container	RteEventToTaskMapping		
Description	Optional reference to an OsTask where the activation of this RteEvent shall be evaluated. The actual execution of the Runnable Entity shall happen in the OsTask referenced by RteMappedToTaskRef.		
Multiplicity	0..1		
Type	Reference to OsTask		
Post-Build Variant Multiplicity	false		
Post-Build Variant Value	false		
Multiplicity Configuration Class	Pre-compile time	X	All Variants
	Link time	–	
	Post-build time	–	
Value Configuration Class	Pre-compile time	X	All Variants
	Link time	–	
	Post-build time	–	
Scope / Dependency	scope: local		

No Included Containers

C.2.2 RteInitializationRunnableBatch

SWS Item	[ECUC_Rte_09115]
Container Name	RteInitializationRunnableBatch
Parent Container	Rte
Description	This container corresponds to an Rte_Init_<shortName of this container> function invoking the mapped RunnableEntities.
Configuration Parameters	

No Included Containers

C.3 Os

C.3.1 OsAlarm

SWS Item	[ECUC_Os_00003]
Container Name	OsAlarm
Parent Container	Os
Description	An OsAlarm may be used to asynchronously inform or activate a specific task. It is possible to start alarms automatically at system start-up depending on the application mode.
Configuration Parameters	

SWS Item	[ECUC_Os_00004]		
Parameter Name	OsAlarmAccessingApplication		
Parent Container	OsAlarm		
Description	Reference to applications which have an access to this object.		
Multiplicity	0..*		
Type	Reference to OsApplication		
Post-Build Variant Multiplicity	false		
Post-Build Variant Value	false		
Multiplicity Configuration Class	Pre-compile time	X	All Variants
	Link time	–	
	Post-build time	–	
Value Configuration Class	Pre-compile time	X	All Variants
	Link time	–	
	Post-build time	–	
Scope / Dependency			

SWS Item	[ECUC_Os_00005]		
Parameter Name	OsAlarmCounterRef		
Parent Container	OsAlarm		
Description	Reference to the assigned counter for that alarm		
Multiplicity	1		
Type	Reference to OsCounter		
Post-Build Variant Value	false		
Value Configuration Class	Pre-compile time	X	All Variants
	Link time	–	
	Post-build time	–	
Scope / Dependency	scope: local		

Included Containers		
Container Name	Multiplicity	Scope / Dependency
OsAlarmAction	1	This container defines which type of notification is used when the alarm expires.
OsAlarmAutostart	0..1	If present this container defines if an alarm is started automatically at system start-up depending on the application mode.

C.3.2 OsApplication

SWS Item	[ECUC_Os_00114]
Container Name	OsApplication
Parent Container	Os
Description	<p>An AUTOSAR OS must be capable of supporting a collection of OS objects (tasks, interrupts, alarms, hooks etc.) that form a cohesive functional unit. This collection of objects is termed an OS-Application.</p> <p>All objects which belong to the same OS-Application have access to each other. Access means to allow to use these objects within API services.</p> <p>Access by other applications can be granted separately.</p>
Configuration Parameters	

SWS Item	[ECUC_Os_00115]		
Parameter Name	OsTrusted		
Parent Container	OsApplication		
Description	<p>Parameter to specify if an OS-Application is trusted or not.</p> <p>true: OS-Application is trusted false: OS-Application is not trusted (default)</p>		
Multiplicity	1		
Type	EcucBooleanParamDef		
Default value	false		
Post-Build Variant Value	false		
Value Configuration Class	Pre-compile time	X	All Variants
	Link time	–	
	Post-build time	–	
Scope / Dependency	<p>scope: ECU</p> <p>dependency: Required for scalability class 3 and 4.</p>		

SWS Item	[ECUC_Os_00395]		
Parameter Name	OsTrustedApplicationDelayTimingViolationCall		
Parent Container	OsApplication		
Description	<p>Parameter to specify if a timing violation which occurs within an trusted OS-Application is raised immediately or if it is delayed until the current task returns to the calling OS-Application (return of CallTrustedFunction) true: violation / call to ProtectionHook() is delayed false: timing violation cause an immediate call to the ProtectionHook().</p>		
Multiplicity	1		
Type	EcucBooleanParamDef		
Default value	true		
Post-Build Variant Value	false		
Value Configuration Class	Pre-compile time	X	All Variants
	Link time	–	
	Post-build time	–	
Scope / Dependency	scope: ECU		

SWS Item	[ECUC_Os_00394]
Parameter Name	OsTrustedApplicationWithProtection
Parent Container	OsApplication





Description	Parameter to specify if a trusted OS-Application is executed with memory protection or not. true: OS-Application runs within a protected environment. This means that write access is limited. false: OS-Application has full write access (default)		
Multiplicity	1		
Type	EcucBooleanParamDef		
Default value	false		
Post-Build Variant Value	false		
Value Configuration Class	Pre-compile time	X	All Variants
	Link time	–	
	Post-build time	–	
Scope / Dependency	scope: ECU		

SWS Item	[ECUC_Os_00231]		
Parameter Name	OsAppAlarmRef		
Parent Container	OsApplication		
Description	Specifies the OsAlarms that belong to the OsApplication.		
Multiplicity	0..*		
Type	Reference to OsAlarm		
Post-Build Variant Multiplicity	false		
Post-Build Variant Value	false		
Multiplicity Configuration Class	Pre-compile time	X	All Variants
	Link time	–	
	Post-build time	–	
Value Configuration Class	Pre-compile time	X	All Variants
	Link time	–	
	Post-build time	–	
Scope / Dependency	scope: ECU		

SWS Item	[ECUC_Os_00234]		
Parameter Name	OsAppCounterRef		
Parent Container	OsApplication		
Description	References the OsCounters that belong to the OsApplication.		
Multiplicity	0..*		
Type	Reference to OsCounter		
Post-Build Variant Multiplicity	false		
Post-Build Variant Value	false		
Multiplicity Configuration Class	Pre-compile time	X	All Variants
	Link time	–	
	Post-build time	–	
Value Configuration Class	Pre-compile time	X	All Variants
	Link time	–	
	Post-build time	–	
Scope / Dependency	scope: ECU		

SWS Item	[ECUC_Os_00392]		
Parameter Name	OsAppEcucPartitionRef		
Parent Container	OsApplication		
Description	Denotes which "EcucPartition" is implemented by this "OSApplication".		
Multiplicity	0..1		
Type	Reference to EcucPartition		
Post-Build Variant Multiplicity	false		
Post-Build Variant Value	false		
Multiplicity Configuration Class	Pre-compile time	X	All Variants
	Link time	–	
	Post-build time	–	
Value Configuration Class	Pre-compile time	X	All Variants
	Link time	–	
	Post-build time	–	
Scope / Dependency			

SWS Item	[ECUC_Os_00221]		
Parameter Name	OsApplsRef		
Parent Container	OsApplication		
Description	references which Oslsrs belong to the OsApplication		
Multiplicity	0..*		
Type	Reference to Oslsr		
Post-Build Variant Multiplicity	false		
Post-Build Variant Value	false		
Multiplicity Configuration Class	Pre-compile time	X	All Variants
	Link time	–	
	Post-build time	–	
Value Configuration Class	Pre-compile time	X	All Variants
	Link time	–	
	Post-build time	–	
Scope / Dependency	scope: ECU		

SWS Item	[ECUC_Os_00393]		
Parameter Name	OsApplicationCoreRef		
Parent Container	OsApplication		
Description	Reference to the Core Definition in the Ecuc Module where the CoreId is defined. This reference is used to describe to which Core the OsApplication is bound.		
Multiplicity	0..1		
Type	Reference to EcucCoreDefinition		
Post-Build Variant Multiplicity	false		
Post-Build Variant Value	false		
Multiplicity Configuration Class	Pre-compile time	X	All Variants
	Link time	–	
	Post-build time	–	
Value Configuration Class	Pre-compile time	X	All Variants
	Link time	–	
	Post-build time	–	





Scope / Dependency	scope: local
---------------------------	--------------

SWS Item	[ECUC_Os_00230]		
Parameter Name	OsAppScheduleTableRef		
Parent Container	OsApplication		
Description	References the OsScheduleTables that belong to the OsApplication.		
Multiplicity	0..*		
Type	Reference to OsScheduleTable		
Post-Build Variant Multiplicity	false		
Post-Build Variant Value	false		
Multiplicity Configuration Class	Pre-compile time	X	All Variants
	Link time	–	
	Post-build time	–	
Value Configuration Class	Pre-compile time	X	All Variants
	Link time	–	
	Post-build time	–	
Scope / Dependency	scope: ECU		

SWS Item	[ECUC_Os_00116]		
Parameter Name	OsAppTaskRef		
Parent Container	OsApplication		
Description	references which OsTasks belong to the OsApplication		
Multiplicity	0..*		
Type	Reference to OsTask		
Post-Build Variant Multiplicity	false		
Post-Build Variant Value	false		
Multiplicity Configuration Class	Pre-compile time	X	All Variants
	Link time	–	
	Post-build time	–	
Value Configuration Class	Pre-compile time	X	All Variants
	Link time	–	
	Post-build time	–	
Scope / Dependency	scope: ECU		

SWS Item	[ECUC_Os_00402]		
Parameter Name	OsMemoryMappingCodeLocationRef		
Parent Container	OsApplication		
Description	Reference to the memory mapping containing details about the section where the code is placed.		
Multiplicity	0..1		
Type	Foreign reference to SW-ADDR-METHOD		
Post-Build Variant Value	false		
Value Configuration Class	Pre-compile time	X	All Variants
	Link time	–	
	Post-build time	–	
Scope / Dependency	scope: ECU		

SWS Item	[ECUC_Os_00120]		
Parameter Name	OsRestartTask		
Parent Container	OsApplication		
Description	<p>Optionally one task of an OS-Application may be defined as Restart Task.</p> <p>Multiplicity = 1: Restart Task is activated by the Operating System if the protection hook requests it.</p> <p>Multiplicity = 0: No task is automatically started after a protection error happened.</p>		
Multiplicity	0..1		
Type	Reference to OsTask		
Post-Build Variant Multiplicity	false		
Post-Build Variant Value	false		
Multiplicity Configuration Class	Pre-compile time	X	All Variants
	Link time	–	
	Post-build time	–	
Value Configuration Class	Pre-compile time	X	All Variants
	Link time	–	
	Post-build time	–	
Scope / Dependency	scope: ECU dependency: Required for scalability class 3 and 4.		

Included Containers		
Container Name	Multiplicity	Scope / Dependency
OsApplicationHooks	1	Container to structure the OS-Application-specific hooks
OsApplicationTrustedFunction	0..*	Container to structure the configuration parameters of trusted functions

C.3.3 OsCounter

SWS Item	[ECUC_Os_00026]		
Container Name	OsCounter		
Parent Container	Os		
Description	Configuration information for the counters that belong to the OsApplication.		
Configuration Parameters			

SWS Item	[ECUC_Os_00027]		
Parameter Name	OsCounterMaxAllowedValue		
Parent Container	OsCounter		
Description	Maximum possible allowed value of the system counter in ticks.		
Multiplicity	1		
Type	EcucIntegerParamDef		
Range	1 .. 18446744073709551615		
Default value	–		
Post-Build Variant Value	false		
Value Configuration Class	Pre-compile time	X	All Variants
	Link time	–	





	Post-build time	–	
Scope / Dependency	scope: local		

SWS Item	[ECUC_Os_00028]		
Parameter Name	OsCounterMinCycle		
Parent Container	OsCounter		
Description	The MINCYCLE attribute specifies the minimum allowed number of counter ticks for a cyclic alarm linked to the counter.		
Multiplicity	1		
Type	EcucIntegerParamDef		
Range	1 .. 18446744073709551615		
Default value	–		
Post-Build Variant Value	false		
Value Configuration Class	Pre-compile time	X	All Variants
	Link time	–	
	Post-build time	–	
Scope / Dependency	scope: local		

SWS Item	[ECUC_Os_00029]		
Parameter Name	OsCounterTicksPerBase		
Parent Container	OsCounter		
Description	The TICKSPERBASE attribute specifies the number of ticks required to reach a counterspecific unit. The interpretation is implementation-specific.		
Multiplicity	1		
Type	EcucIntegerParamDef		
Range	1 .. 4294967295		
Default value	–		
Post-Build Variant Value	false		
Value Configuration Class	Pre-compile time	X	All Variants
	Link time	–	
	Post-build time	–	
Scope / Dependency	scope: local		

SWS Item	[ECUC_Os_00255]		
Parameter Name	OsCounterType		
Parent Container	OsCounter		
Description	This parameter contains the natural type or unit of the counter.		
Multiplicity	1		
Type	EcucEnumerationParamDef		
Range	HARDWARE	This counter is driven by some hardware e.g. a hardware timer unit.	
	SOFTWARE	The counter is driven by some software which calls the IncrementCounter service.	
Post-Build Variant Value	false		
Value Configuration Class	Pre-compile time	X	All Variants
	Link time	–	
	Post-build time	–	
Scope / Dependency	scope: ECU		

SWS Item	[ECUC_Os_00030]		
Parameter Name	OsSecondsPerTick		
Parent Container	OsCounter		
Description	Time of one counter tick in seconds.		
Multiplicity	0..1		
Type	EcucFloatParamDef		
Range	[0 .. INF]		
Default value	-		
Post-Build Variant Multiplicity	false		
Post-Build Variant Value	false		
Multiplicity Configuration Class	Pre-compile time	X	All Variants
	Link time	-	
	Post-build time	-	
Value Configuration Class	Pre-compile time	X	All Variants
	Link time	-	
	Post-build time	-	
Scope / Dependency	scope: ECU		

SWS Item	[ECUC_Os_00031]		
Parameter Name	OsCounterAccessingApplication		
Parent Container	OsCounter		
Description	Reference to applications which have an access to this object.		
Multiplicity	0..*		
Type	Reference to OsApplication		
Post-Build Variant Multiplicity	false		
Post-Build Variant Value	false		
Multiplicity Configuration Class	Pre-compile time	X	All Variants
	Link time	-	
	Post-build time	-	
Value Configuration Class	Pre-compile time	X	All Variants
	Link time	-	
	Post-build time	-	
Scope / Dependency	scope: local		

Included Containers		
Container Name	Multiplicity	Scope / Dependency
OsDriver	0..1	<p>This Container contains the information who will drive the counter. This configuration is only valid if the counter has Os CounterType set to HARDWARE.</p> <p>If the container does not exist (multiplicity=0) the timer is managed by the OS internally (OSINTERNAL).</p> <p>If the container exists the OS can use the GPT interface to manage the timer. The user have to supply the GPT channel.</p> <p>If the counter is driven by some other (external to the OS) source (like a TPU for example) this must be described as a vendor specific extension.</p>





Included Containers		
Container Name	Multiplicity	Scope / Dependency
OsTimeConstant	0..*	Allows the user to define constants which can be e.g. used to compare time values with timer tick values. A time value will be converted to a timer tick value during generation and can later on accessed via the OsConstName. The conversation is done by rounding time values to the nearest fitting tick value.

C.3.4 OsEvent

SWS Item	[ECUC_Os_00033]
Container Name	OsEvent
Parent Container	Os
Description	Representation of OS events in the configuration context. Adopted from the ISO 17356-6 specification.
Configuration Parameters	

SWS Item	[ECUC_Os_00034]		
Parameter Name	OsEventMask		
Parent Container	OsEvent		
Description	If event mask would be set to AUTO in OIL, this parameter should be omitted here.		
Multiplicity	0..1		
Type	EcucIntegerParamDef		
Range	0 .. 18446744073709551615		
Default value	-		
Post-Build Variant Multiplicity	false		
Post-Build Variant Value	false		
Multiplicity Configuration Class	Pre-compile time	X	All Variants
	Link time	-	
	Post-build time	-	
Value Configuration Class	Pre-compile time	X	All Variants
	Link time	-	
	Post-build time	-	
Scope / Dependency	scope: local		

No Included Containers

C.3.5 OsResource

SWS Item	[ECUC_Os_00252]
Container Name	OsResource
Parent Container	Os





Description	An OsResource object is used to co-ordinate the concurrent access by tasks and ISRs to a shared resource, e.g. the scheduler, any program sequence, memory or any hardware area.
Configuration Parameters	

SWS Item	[ECUC_Os_00050]		
Parameter Name	OsResourceProperty		
Parent Container	OsResource		
Description	This specifies the type of the resource.		
Multiplicity	1		
Type	EcucEnumerationParamDef		
Range	INTERNAL	The resource is an internal resource.	
	LINKED	The resource is a linked resource (a second name for a existing resource).	
	STANDARD	The resource is a standard resource.	
Post-Build Variant Value	false		
Value Configuration Class	Pre-compile time	X	All Variants
	Link time	–	
	Post-build time	–	
Scope / Dependency	scope: local		

SWS Item	[ECUC_Os_00051]		
Parameter Name	OsResourceAccessingApplication		
Parent Container	OsResource		
Description	Reference to applications which have an access to this object.		
Multiplicity	0..*		
Type	Reference to OsApplication		
Post-Build Variant Multiplicity	false		
Post-Build Variant Value	false		
Multiplicity Configuration Class	Pre-compile time	X	All Variants
	Link time	–	
	Post-build time	–	
Value Configuration Class	Pre-compile time	X	All Variants
	Link time	–	
	Post-build time	–	
Scope / Dependency	scope: local		

SWS Item	[ECUC_Os_00052]		
Parameter Name	OsResourceLinkedResourceRef		
Parent Container	OsResource		
Description	The link to the resource. Must be valid if OsResourceProperty is LINKED. If Os ResourceProperty is not LINKED the value is ignored.		
Multiplicity	0..1		
Type	Reference to OsResource		
Post-Build Variant Multiplicity	false		
Post-Build Variant Value	false		
Multiplicity Configuration Class	Pre-compile time	X	All Variants
	Link time	–	





	Post-build time	–	
Value Configuration Class	Pre-compile time	X	All Variants
	Link time	–	
	Post-build time	–	
Scope / Dependency	scope: local		

No Included Containers

C.3.6 OsScheduleTable

SWS Item	[ECUC_Os_00141]		
Container Name	OsScheduleTable		
Parent Container	Os		
Description	An OsScheduleTable addresses the synchronization issue by providing an encapsulation of a statically defined set of alarms that cannot be modified at runtime.		
Configuration Parameters			

SWS Item	[ECUC_Os_00053]		
Parameter Name	OsScheduleTableDuration		
Parent Container	OsScheduleTable		
Description	This parameter defines the modulus of the schedule table (in ticks).		
Multiplicity	1		
Type	EcucIntegerParamDef		
Range	0 .. 18446744073709551615		
Default value	–		
Post-Build Variant Value	false		
Value Configuration Class	Pre-compile time	X	All Variants
	Link time	–	
	Post-build time	–	
Scope / Dependency	scope: local		

SWS Item	[ECUC_Os_00144]		
Parameter Name	OsScheduleTableRepeating		
Parent Container	OsScheduleTable		
Description	true: first expiry point on the schedule table shall be processed at final expiry point delay ticks after the final expiry point is processed. false: the schedule table processing stops when the final expiry point is processed.		
Multiplicity	1		
Type	EcucBooleanParamDef		
Default value	–		
Post-Build Variant Value	false		
Value Configuration Class	Pre-compile time	X	All Variants
	Link time	–	
	Post-build time	–	
Scope / Dependency	scope: ECU		

SWS Item	[ECUC_Os_00145]		
Parameter Name	OsScheduleTableCounterRef		
Parent Container	OsScheduleTable		
Description	This parameter contains a reference to the counter which drives the schedule table.		
Multiplicity	1		
Type	Reference to OsCounter		
Post-Build Variant Value	false		
Value Configuration Class	Pre-compile time	X	All Variants
	Link time	–	
	Post-build time	–	
Scope / Dependency	scope: ECU		

SWS Item	[ECUC_Os_00054]		
Parameter Name	OsSchTblAccessingApplication		
Parent Container	OsScheduleTable		
Description	Reference to applications which have an access to this object.		
Multiplicity	0..*		
Type	Reference to OsApplication		
Post-Build Variant Multiplicity	false		
Post-Build Variant Value	false		
Multiplicity Configuration Class	Pre-compile time	X	All Variants
	Link time	–	
	Post-build time	–	
Value Configuration Class	Pre-compile time	X	All Variants
	Link time	–	
	Post-build time	–	
Scope / Dependency	scope: local		

Included Containers		
Container Name	Multiplicity	Scope / Dependency
OsScheduleTableAutostart	0..1	This container specifies if and how the schedule table is started on startup of the Operating System. The options to start a schedule table correspond to the API calls to start schedule tables during runtime.
OsScheduleTableExpiryPoint	1..*	The point on a Schedule Table at which the OS activates tasks and/or sets events
OsScheduleTableSync	0..1	This container specifies the synchronization parameters of the schedule table.

C.3.7 OsScheduleTableExpiryPoint

SWS Item	[ECUC_Os_00143]
Container Name	OsScheduleTableExpiryPoint
Parent Container	OsScheduleTable
Description	The point on a Schedule Table at which the OS activates tasks and/or sets events
Configuration Parameters	

SWS Item	[ECUC_Os_00062]		
Parameter Name	OsScheduleTblExpPointOffset		
Parent Container	OsScheduleTableExpiryPoint		
Description	The offset from zero (in ticks) at which the expiry point is to be processed.		
Multiplicity	1		
Type	EcucIntegerParamDef		
Range	0 .. 18446744073709551615		
Default value	-		
Post-Build Variant Value	false		
Value Configuration Class	Pre-compile time	X	All Variants
	Link time	-	
	Post-build time	-	
Scope / Dependency			

Included Containers		
Container Name	Multiplicity	Scope / Dependency
OsScheduleTableEventSetting	0..*	Event that is triggered by that schedule table.
OsScheduleTableTaskActivation	0..*	Task that is triggered by that schedule table.
OsScheduleTblAdjustableExpPoint	0..1	Adjustable expiry point

C.3.8 OsSpinlock

SWS Item	[ECUC_Os_00258]		
Container Name	OsSpinlock		
Parent Container	Os		
Description	An OsSpinlock object is used to co-ordinate concurrent access by TASKs/ISR2s on different cores to a shared resource.		
Configuration Parameters			

SWS Item	[ECUC_Os_01038]		
Parameter Name	OsSpinlockLockMethod		
Parent Container	OsSpinlock		
Description	Lock method which is used when a spinlock is taken. Note that it is possible that a user (e.g. a Task) might hold more than one spinlock. In this case the last lock taken is forced to use at least a lock method which locks as strong as the current one.		
Multiplicity	1		
Type	EcucEnumerationParamDef		
Range	LOCK_ALL_INTERRUPTS	-	
	LOCK_CAT2_INTERRUPTS	-	
	LOCK_NOTHING	-	
	LOCK_WITH_RES_SCHEDULER	-	
Default value	LOCK_NOTHING		
Post-Build Variant Value	false		
Value Configuration Class	Pre-compile time	X	All Variants





	Link time	–	
	Post-build time	–	
Scope / Dependency	scope: local		

SWS Item	[ECUC_Os_01021]		
Parameter Name	OsSpinlockAccessingApplication		
Parent Container	OsSpinlock		
Description	Reference to OsApplications that have an access to this object.		
Multiplicity	1..*		
Type	Reference to OsApplication		
Post-Build Variant Multiplicity	false		
Post-Build Variant Value	false		
Multiplicity Configuration Class	Pre-compile time	X	All Variants
	Link time	–	
	Post-build time	–	
Value Configuration Class	Pre-compile time	X	All Variants
	Link time	–	
	Post-build time	–	
Scope / Dependency	scope: local		

SWS Item	[ECUC_Os_01022]		
Parameter Name	OsSpinlockSuccessor		
Parent Container	OsSpinlock		
Description	<p>Reference to OsApplications that have an access to this object.</p> <p>To check whether a spinlock can be occupied (in a nested way) without any danger of deadlock, a linked list of spinlocks can be defined. A spinlock can only be occupied in the order of the linked list. It is allowed to skip a spinlock.</p> <p>If no linked list is specified, spinlocks cannot be nested.</p>		
Multiplicity	0..1		
Type	Reference to OsSpinlock		
Post-Build Variant Multiplicity	false		
Post-Build Variant Value	false		
Multiplicity Configuration Class	Pre-compile time	X	All Variants
	Link time	–	
	Post-build time	–	
Value Configuration Class	Pre-compile time	X	All Variants
	Link time	–	
	Post-build time	–	
Scope / Dependency	scope: local		

No Included Containers

C.3.9 OsTask

SWS Item	[ECUC_Os_00073]
Container Name	OsTask
Parent Container	Os
Description	This container represents an ISO 17356 task.
Configuration Parameters	

SWS Item	[ECUC_Os_00074]		
Parameter Name	OsTaskActivation		
Parent Container	OsTask		
Description	This attribute defines the maximum number of queued activation requests for the task. A value equal to "1" means that at any time only a single activation is permitted for this task. Note that the value must be a natural number starting at 1.		
Multiplicity	1		
Type	EcucIntegerParamDef		
Range	1 .. 4294967295		
Default value	-		
Post-Build Variant Value	false		
Value Configuration Class	Pre-compile time	X	All Variants
	Link time	-	
	Post-build time	-	
Scope / Dependency	scope: local		

SWS Item	[ECUC_Os_00404]		
Parameter Name	OsTaskPeriod		
Parent Container	OsTask		
Description	<p>This parameter specifies the period in seconds of this task in case of a cyclically activated task.</p> <p>If this parameter is not given the task can be activated sporadically or cyclically with a unknown period value.</p> <p>This value is information, e.g. for time base calculations in the RTE in case Timing Events are mapped onto this OsTask. Be aware, that this parameter is not supposed to be relevant for the OS! This information is given as part of the OS configuration to support configuration work flows using a fixed set of OsTasks.</p>		
Multiplicity	0..1		
Type	EcucFloatParamDef		
Range	[-INF .. INF]		
Default value	-		
Post-Build Variant Multiplicity	false		
Post-Build Variant Value	false		
Multiplicity Configuration Class	Pre-compile time	X	All Variants
	Link time	-	
	Post-build time	-	
Value Configuration Class	Pre-compile time	X	All Variants
	Link time	-	
	Post-build time	-	
Scope / Dependency	scope: ECU		

SWS Item	[ECUC_Os_00075]		
Parameter Name	OsTaskPriority		
Parent Container	OsTask		
Description	<p>The priority of a task is defined by the value of this attribute. This value has to be understood as a relative value, i.e. the values show only the relative ordering of the tasks.</p> <p>ISO 17356-3 defines the lowest priority as zero (0); larger values correspond to higher priorities.</p>		
Multiplicity	1		
Type	EcucIntegerParamDef		
Range	0 .. 4294967295		
Default value	-		
Post-Build Variant Value	false		
Value Configuration Class	Pre-compile time	X	All Variants
	Link time	-	
	Post-build time	-	
Scope / Dependency	scope: local		

SWS Item	[ECUC_Os_00076]		
Parameter Name	OsTaskSchedule		
Parent Container	OsTask		
Description	<p>The OsTaskSchedule attribute defines the preemptability of the task.</p> <p>If this attribute is set to NON, no internal resources may be assigned to this task.</p>		
Multiplicity	1		
Type	EcucEnumerationParamDef		
Range	FULL		Task is preemptable.
	NON		Task is not preemptable.
Post-Build Variant Value	false		
Value Configuration Class	Pre-compile time	X	All Variants
	Link time	-	
	Post-build time	-	
Scope / Dependency	scope: local		

SWS Item	[ECUC_Os_00402]		
Parameter Name	OsMemoryMappingCodeLocationRef		
Parent Container	OsTask		
Description	Reference to the memory mapping containing details about the section where the code is placed.		
Multiplicity	0..1		
Type	Foreign reference to SW-ADDR-METHOD		
Post-Build Variant Value	false		
Value Configuration Class	Pre-compile time	X	All Variants
	Link time	-	
	Post-build time	-	
Scope / Dependency	scope: ECU		

SWS Item	[ECUC_Os_00077]		
Parameter Name	OsTaskAccessingApplication		
Parent Container	OsTask		
Description	Reference to applications which have an access to this object.		
Multiplicity	0..*		
Type	Reference to OsApplication		
Post-Build Variant Multiplicity	false		
Post-Build Variant Value	false		
Multiplicity Configuration Class	Pre-compile time	X	All Variants
	Link time	–	
	Post-build time	–	
Value Configuration Class	Pre-compile time	X	All Variants
	Link time	–	
	Post-build time	–	
Scope / Dependency	scope: local		

SWS Item	[ECUC_Os_00078]		
Parameter Name	OsTaskEventRef		
Parent Container	OsTask		
Description	This reference defines the list of events the extended task may react on.		
Multiplicity	0..*		
Type	Reference to OsEvent		
Post-Build Variant Multiplicity	false		
Post-Build Variant Value	false		
Multiplicity Configuration Class	Pre-compile time	X	All Variants
	Link time	–	
	Post-build time	–	
Value Configuration Class	Pre-compile time	X	All Variants
	Link time	–	
	Post-build time	–	
Scope / Dependency	scope: local		

SWS Item	[ECUC_Os_00079]		
Parameter Name	OsTaskResourceRef		
Parent Container	OsTask		
Description	This reference defines a list of resources accessed by this task.		
Multiplicity	0..*		
Type	Reference to OsResource		
Post-Build Variant Multiplicity	false		
Post-Build Variant Value	false		
Multiplicity Configuration Class	Pre-compile time	X	All Variants
	Link time	–	
	Post-build time	–	
Value Configuration Class	Pre-compile time	X	All Variants
	Link time	–	
	Post-build time	–	
Scope / Dependency	scope: local		

Included Containers		
Container Name	Multiplicity	Scope / Dependency
OsTaskAutostart	0..1	This container determines whether the task is activated during the system start-up procedure or not for some specific application modes. If the task shall be activated during the system start-up, this container is present and holds the references to the application modes in which the task is auto-started.
OsTaskTimingProtection	0..1	This container contains all parameters regarding timing protection of the task.

C.4 NvM

C.4.1 NvMBlockDescriptor

SWS Item	[ECUC_NvM_00061]
Container Name	NvMBlockDescriptor
Parent Container	NvM
Description	Container for a management structure to configure the composition of a given NVRAM Block Management Type. Its multiplicity describes the number of configured NVRAM blocks, one block is required to be configured. The NVRAM block descriptors are condensed in the NVRAM block descriptor table.
Configuration Parameters	

SWS Item	[ECUC_NvM_00476]		
Parameter Name	NvMBlockCrcType		
Parent Container	NvMBlockDescriptor		
Description	Defines CRC data width for the NVRAM block. Default: NVM_CRC16, i.e. CRC16 will be used if NVM_BLOCK_USE_CRC==true		
Multiplicity	0..1		
Type	EcucEnumerationParamDef		
Range	NVM_CRC16	(Default) CRC16 will be used if NVM_BLOCK_USE_CRC==true.	
	NVM_CRC32	CRC32 is selected for this NVRAM block if NVM_BLOCK_USE_CRC==true.	
	NVM_CRC8	CRC8 is selected for this NVRAM block if NVM_BLOCK_USE_CRC==true.	
Post-Build Variant Multiplicity	false		
Post-Build Variant Value	false		
Multiplicity Configuration Class	Pre-compile time	X	VARIANT-PRE-COMPILE
	Link time	X	VARIANT-LINK-TIME
	Post-build time	–	
Value Configuration Class	Pre-compile time	X	VARIANT-PRE-COMPILE
	Link time	X	VARIANT-LINK-TIME
	Post-build time	–	
Scope / Dependency	scope: local dependency: NVM_BLOCK_USE_CRC, NVM_CALC_RAM_BLOCK_CRC		

SWS Item	[ECUC_NvM_00554]		
Parameter Name	NvMBlockHeaderInclude		
Parent Container	NvMBlockDescriptor		
Description	Defines the header file where the owner of the NVRAM block has the declarations of the permanent RAM data block, ROM data block (if configured) and the callback function prototype for each configured callback. If no permanent RAM block, ROM block or callback functions are configured then this configuration parameter shall be ignored.		
Multiplicity	0..1		
Type	EcucStringParamDef		
Default value	-		
Regular Expression	-		
Post-Build Variant Multiplicity	false		
Post-Build Variant Value	false		
Multiplicity Configuration Class	Pre-compile time	X	VARIANT-PRE-COMPILE
	Link time	X	VARIANT-LINK-TIME
	Post-build time	-	
Value Configuration Class	Pre-compile time	X	VARIANT-PRE-COMPILE
	Link time	X	VARIANT-LINK-TIME
	Post-build time	-	
Scope / Dependency	scope: local		

SWS Item	[ECUC_NvM_00477]		
Parameter Name	NvMBlockJobPriority		
Parent Container	NvMBlockDescriptor		
Description	Defines the job priority for a NVRAM block (0 = Immediate priority).		
Multiplicity	1		
Type	EcucIntegerParamDef		
Range	0 .. 255		
Default value	-		
Post-Build Variant Value	false		
Value Configuration Class	Pre-compile time	X	VARIANT-PRE-COMPILE
	Link time	X	VARIANT-LINK-TIME
	Post-build time	-	
Scope / Dependency	scope: local		

SWS Item	[ECUC_NvM_00062]		
Parameter Name	NvMBlockManagementType		
Parent Container	NvMBlockDescriptor		
Description	Defines the block management type for the NVRAM block.[SWS_NvM_00137]		
Multiplicity	1		
Type	EcucEnumerationParamDef		
Range	NVM_BLOCK_DATASET	NVRAM block is configured to be of dataset type.	
	NVM_BLOCK_NATIVE	NVRAM block is configured to be of native type.	
	NVM_BLOCK_REDUNDANT	NVRAM block is configured to be of redundant type.	
Post-Build Variant Value	false		
Value Configuration Class	Pre-compile time	X	VARIANT-PRE-COMPILE





	Link time	X	VARIANT-LINK-TIME
	Post-build time	–	
Scope / Dependency	scope: local		

SWS Item	[ECUC_NvM_00557]		
Parameter Name	NvMBlockUseAutoValidation		
Parent Container	NvMBlockDescriptor		
Description	Defines whether the RAM Block shall be auto validated during shutdown phase. true: if auto validation mechanism is used, false: otherwise		
Multiplicity	1		
Type	EcucBooleanParamDef		
Default value	false		
Post-Build Variant Value	false		
Value Configuration Class	Pre-compile time	X	VARIANT-PRE-COMPILE
	Link time	X	VARIANT-LINK-TIME
	Post-build time	–	
Scope / Dependency	scope: local		

SWS Item	[ECUC_NvM_00563]		
Parameter Name	NvMBlockUseCompression		
Parent Container	NvMBlockDescriptor		
Description	Defines whether the data is compressed before written. true: data compression activated (takes more time to read and write) false: no compression Tags: atp.Status=draft		
Multiplicity	1		
Type	EcucBooleanParamDef		
Default value	false		
Post-Build Variant Value	false		
Value Configuration Class	Pre-compile time	X	VARIANT-PRE-COMPILE
	Link time	X	VARIANT-LINK-TIME
	Post-build time	–	
Scope / Dependency	scope: local		

SWS Item	[ECUC_NvM_00036]		
Parameter Name	NvMBlockUseCrc		
Parent Container	NvMBlockDescriptor		
Description	Defines CRC usage for the NVRAM block, i.e. memory space for CRC is reserved in RAM and NV memory. true: CRC will be used for this NVRAM block. false: CRC will not be used for this NVRAM block. Note: Configuring CRC for a block with immediate priority is not recommended, since the CRC calculation may extend over more than one NvM main function and this could increase the time of writing the immediate data significantly, thus defeating the purpose of immediate priority.		
Multiplicity	1		
Type	EcucBooleanParamDef		
Default value	–		
Post-Build Variant Value	false		





Value Configuration Class	Pre-compile time	X	VARIANT-PRE-COMPILE
	Link time	X	VARIANT-LINK-TIME
	Post-build time	–	
Scope / Dependency	scope: local		

SWS Item	[ECUC_NvM_00556]		
Parameter Name	NvMBlockUseCRCCompMechanism		
Parent Container	NvMBlockDescriptor		
Description	<p>Defines whether the CRC of the RAM Block shall be compared during a write job with the CRC which was calculated during the last successful read or write job.</p> <p>true: if compare mechanism is used, false: otherwise</p>		
Multiplicity	1		
Type	EcucBooleanParamDef		
Default value	false		
Post-Build Variant Value	false		
Value Configuration Class	Pre-compile time	X	VARIANT-PRE-COMPILE
	Link time	X	VARIANT-LINK-TIME
	Post-build time	–	
Scope / Dependency	scope: local dependency: False if NvMBlockUseCrc = False		

SWS Item	[ECUC_NvM_00559]		
Parameter Name	NvMBlockUsePort		
Parent Container	NvMBlockDescriptor		
Description	<p>If this parameter is true it defines whether:</p> <ul style="list-style-type: none"> the port with interface 'NvMMirror' for synchronization mechanism callbacks are generated if the parameter NvMBlockUseSyncMechanism is configured TRUE; the port with interface 'NvMNotifyInitBlock' for initialization block callback is generated if NvMInitBlockCallback parameter is configured (independent of the content); the port with interface 'NvMNotifyJobFinished' for single block callback is generated if NvMSingleBlockCallback parameter is configured (independent of the content); the port with interface 'NvMAdmin' for SetBlockProtection operation is generated. 		
Multiplicity	1		
Type	EcucBooleanParamDef		
Default value	–		
Multiplicity Configuration Class	Pre-compile time	X	VARIANT-PRE-COMPILE
	Link time	X	VARIANT-LINK-TIME
	Post-build time	–	
Value Configuration Class	Pre-compile time	X	VARIANT-PRE-COMPILE
	Link time	X	VARIANT-LINK-TIME
	Post-build time	–	
Scope / Dependency	scope: local		

SWS Item	[ECUC_NvM_00552]		
Parameter Name	NvMBlockUseSetRamBlockStatus		
Parent Container	NvMBlockDescriptor		
Description	<p>Defines if NvMSetRamBlockStatusApi shall be used for this block or not.</p> <p>Note: If NvMSetRamBlockStatusApi is disabled this configuration parameter shall be ignored.</p> <p>true: calling of NvMSetRamBlockStatus for this RAM block shall set the status of the RAM block.</p> <p>false: calling of NvMSetRamBlockStatus for this RAM block shall be ignored.</p>		
Multiplicity	1		
Type	EcucBooleanParamDef		
Default value	-		
Post-Build Variant Value	false		
Value Configuration Class	Pre-compile time	X	VARIANT-PRE-COMPILE
	Link time	X	VARIANT-LINK-TIME
	Post-build time	-	
Scope / Dependency	scope: local		

SWS Item	[ECUC_NvM_00519]		
Parameter Name	NvMBlockUseSyncMechanism		
Parent Container	NvMBlockDescriptor		
Description	<p>Defines whether an explicit synchronization mechanism with a RAM mirror and callback routines for transferring data to and from NvM module's RAM mirror is used for NV block. true if synchronization mechanism is used, false otherwise.</p>		
Multiplicity	1		
Type	EcucBooleanParamDef		
Default value	false		
Post-Build Variant Value	false		
Value Configuration Class	Pre-compile time	X	VARIANT-PRE-COMPILE
	Link time	X	VARIANT-LINK-TIME
	Post-build time	-	
Scope / Dependency	scope: local		

SWS Item	[ECUC_NvM_00033]		
Parameter Name	NvMBlockWriteProt		
Parent Container	NvMBlockDescriptor		
Description	<p>Defines an initial write protection of the NV block</p> <p>true: Initial block write protection is enabled. false: Initial block write protection is disabled.</p>		
Multiplicity	1		
Type	EcucBooleanParamDef		
Default value	-		
Post-Build Variant Value	false		
Value Configuration Class	Pre-compile time	X	VARIANT-PRE-COMPILE
	Link time	X	VARIANT-LINK-TIME
	Post-build time	-	
Scope / Dependency	scope: local		

SWS Item	[ECUC_NvM_00551]		
Parameter Name	NvMBswMBlockStatusInformation		
Parent Container	NvMBlockDescriptor		
Description	This parameter specifies whether BswM is informed about the current status of the specified block. True: Call BswM_NvM_CurrentBlockMode on changes False: Don't inform BswM at all		
Multiplicity	1		
Type	EcucBooleanParamDef		
Default value	false		
Post-Build Variant Value	false		
Value Configuration Class	Pre-compile time	X	VARIANT-PRE-COMPILE
	Link time	X	VARIANT-LINK-TIME
	Post-build time	–	
Scope / Dependency	scope: local		

SWS Item	[ECUC_NvM_00119]		
Parameter Name	NvMCalcRamBlockCrc		
Parent Container	NvMBlockDescriptor		
Description	Defines CRC (re)calculation for the permanent RAM block or NVRAM blocks which are configured to use explicit synchronization mechanism. true: CRC will be (re)calculated for this permanent RAM block. false: CRC will not be (re)calculated for this permanent RAM block.		
Multiplicity	0..1		
Type	EcucBooleanParamDef		
Default value	–		
Post-Build Variant Multiplicity	false		
Post-Build Variant Value	false		
Multiplicity Configuration Class	Pre-compile time	X	VARIANT-PRE-COMPILE
	Link time	X	VARIANT-LINK-TIME
	Post-build time	–	
Value Configuration Class	Pre-compile time	X	VARIANT-PRE-COMPILE
	Link time	X	VARIANT-LINK-TIME
	Post-build time	–	
Scope / Dependency	scope: local dependency: NVM_BLOCK_USE_CRC		

SWS Item	[ECUC_NvM_00533]		
Parameter Name	NvMMaxNumOfReadRetries		
Parent Container	NvMBlockDescriptor		
Description	Defines the maximum number of read retries.		
Multiplicity	1		
Type	EcucIntegerParamDef		
Range	0 .. 7		
Default value	0		
Post-Build Variant Value	false		
Value Configuration Class	Pre-compile time	X	VARIANT-PRE-COMPILE
	Link time	X	VARIANT-LINK-TIME
	Post-build time	–	





Scope / Dependency	scope: local
---------------------------	--------------

SWS Item	[ECUC_NvM_00499]		
Parameter Name	NvMMaxNumOfWriteRetries		
Parent Container	NvMBlockDescriptor		
Description	Defines the maximum number of write retries for a NVRAM block with [ECUC_NvM_00061] . Regardless of configuration a consistency check (and maybe write retries) are always forced for each block which is processed by the request NvM_WriteAll and NvM_WriteBlock.		
Multiplicity	1		
Type	EcucIntegerParamDef		
Range	0 .. 7		
Default value	-		
Post-Build Variant Value	false		
Value Configuration Class	Pre-compile time	X	VARIANT-PRE-COMPILE
	Link time	X	VARIANT-LINK-TIME
	Post-build time	-	
Scope / Dependency	scope: local		

SWS Item	[ECUC_NvM_00478]		
Parameter Name	NvMNvBlockBaseNumber		
Parent Container	NvMBlockDescriptor		
Description	Configuration parameter to perform the link between the NVM_NVRAM_BLOCK_IDENTIFIER used by the SW-Cs and the FEE_BLOCK_NUMBER expected by the memory abstraction modules. The parameter value equals the FEE_BLOCK_NUMBER or EA_BLOCK_NUMBER shifted to the right by NvMDatasetSelectionBits bits. (ref. to chapter 7.1.2.1). Calculation Formula: value = TargetBlockReference.[Ea/Fee]BlockConfiguration.[Ea/Fee]BlockNumber >> NvMDatasetSelectionBits		
Multiplicity	1		
Type	EcucIntegerParamDef		
Range	1 .. 65534		
Default value	-		
Post-Build Variant Value	false		
Value Configuration Class	Pre-compile time	X	VARIANT-PRE-COMPILE
	Link time	X	VARIANT-LINK-TIME
	Post-build time	-	
Scope / Dependency	scope: local dependency: FEE_BLOCK_NUMBER, EA_BLOCK_NUMBER		

SWS Item	[ECUC_NvM_00479]		
Parameter Name	NvMNvBlockLength		
Parent Container	NvMBlockDescriptor		





Description	Defines the NV block data length in bytes. Note: The implementer can add the attribute 'withAuto' to the parameter definition which indicates that the length can be calculated by the generator automatically (e.g. by using a parser that searches and analyzes the data structure corresponding to the block). When 'withAuto' is set to 'true' for this parameter definition the 'isAutoValue' can be set to 'true'. If 'isAutoValue' is set to 'true' the actual value will not be considered during ECU Configuration but will be (re-)calculated by the code generator and stored in the value attribute afterwards.		
Multiplicity	1		
Type	EcucIntegerParamDef		
Range	1 .. 65535		
Default value	-		
Post-Build Variant Value	false		
Value Configuration Class	Pre-compile time	X	VARIANT-PRE-COMPILE
	Link time	X	VARIANT-LINK-TIME
	Post-build time	-	
Scope / Dependency	scope: local		

SWS Item	[ECUC_NvM_00480]		
Parameter Name	NvMNvBlockNum		
Parent Container	NvMBlockDescriptor		
Description	Defines the number of multiple NV blocks in a contiguous area according to the given block management type. 1-255 For NVRAM blocks to be configured of block management type NVM_BLOCK_DATASET. The actual range is limited according to SWS_NvM_00444. 1 For NVRAM blocks to be configured of block management type NVM_BLOCK_NATIVE 2 For NVRAM blocks to be configured of block management type NVM_BLOCK_REDUNDANT		
Multiplicity	1		
Type	EcucIntegerParamDef		
Range	1 .. 255		
Default value	-		
Post-Build Variant Value	false		
Value Configuration Class	Pre-compile time	X	VARIANT-PRE-COMPILE
	Link time	X	VARIANT-LINK-TIME
	Post-build time	-	
Scope / Dependency	scope: local dependency: NVM_BLOCK_MANAGEMENT_TYPE		

SWS Item	[ECUC_NvM_00481]		
Parameter Name	NvMNvramBlockIdentifier		
Parent Container	NvMBlockDescriptor		
Description	Identification of a NVRAM block via a unique block identifier. Implementation Type: NvM_BlockIdType. $min = 2 \ max = 2^{(16 - NVM_DATASET_SELECTION_BITS)} - 1$ Reserved NVRAM block IDs: 0 -> to derive multi block request results via NvM_GetErrorStatus 1 -> redundant NVRAM block which holds the configuration ID (generation tool should check that this block is correctly configured from type, CRC and size point of view)		





Multiplicity	1		
Type	EcucIntegerParamDef (Symbolic Name generated for this parameter)		
Range	2 .. 65535		
Default value	-		
Post-Build Variant Value	false		
Value Configuration Class	Pre-compile time	X	All Variants
	Link time	-	
	Post-build time	-	
Scope / Dependency	scope: local dependency: NVM_DATASET_SELECTION_BITS		

SWS Item	[ECUC_NvM_00035]		
Parameter Name	NvMNvramDeviceId		
Parent Container	NvMBlockDescriptor		
Description	Defines the NVRAM device ID where the NVRAM block is located. Calculation Formula: value = TargetBlockReference.[Ea/Fee]DeviceIndex		
Multiplicity	1		
Type	EcucIntegerParamDef		
Range	0 .. 1		
Default value	-		
Post-Build Variant Value	false		
Value Configuration Class	Pre-compile time	X	VARIANT-PRE-COMPILE
	Link time	X	VARIANT-LINK-TIME
	Post-build time	-	
Scope / Dependency	scope: local dependency: EA_DEVICE_INDEX, FEE_DEVICE_INDEX		

SWS Item	[ECUC_NvM_00482]		
Parameter Name	NvMRamBlockDataAddress		
Parent Container	NvMBlockDescriptor		
Description	Defines the start address of the RAM block data. If this is not configured, no permanent RAM data block is available for the selected block management type.		
Multiplicity	0..1		
Type	EcucStringParamDef		
Default value	-		
Regular Expression	-		
Post-Build Variant Multiplicity	false		
Post-Build Variant Value	false		
Multiplicity Configuration Class	Pre-compile time	X	VARIANT-PRE-COMPILE
	Link time	X	VARIANT-LINK-TIME
	Post-build time	-	
Value Configuration Class	Pre-compile time	X	VARIANT-PRE-COMPILE
	Link time	X	VARIANT-LINK-TIME
	Post-build time	-	
Scope / Dependency	scope: local		

SWS Item	[ECUC_NvM_00521]		
Parameter Name	NvMReadRamBlockFromNvCallback		
Parent Container	NvMBlockDescriptor		
Description	Entry address of a block specific callback routine which shall be called in order to let the application copy data from the NvM module's mirror to RAM block. Implementation type: Std_ReturnType E_OK: copy was successful E_NOT_OK: copy was not successful, callback routine to be called again		
Multiplicity	0..1		
Type	EcucFunctionNameDef		
Default value	-		
Regular Expression	-		
Post-Build Variant Multiplicity	false		
Post-Build Variant Value	false		
Multiplicity Configuration Class	Pre-compile time	X	VARIANT-PRE-COMPILE
	Link time	X	VARIANT-LINK-TIME
	Post-build time	-	
Value Configuration Class	Pre-compile time	X	VARIANT-PRE-COMPILE
	Link time	X	VARIANT-LINK-TIME
	Post-build time	-	
Scope / Dependency	scope: local		

SWS Item	[ECUC_NvM_00483]		
Parameter Name	NvMResistantToChangedSw		
Parent Container	NvMBlockDescriptor		
Description	Defines whether a NVRAM block shall be treated resistant to configuration changes or not. If there is no default data available at configuration time then the application shall be responsible for providing the default initialization data. In this case the application has to use NvM_GetErrorStatus() to be able to distinguish between first initialization and corrupted data. true: NVRAM block is resistant to changed software. false: NVRAM block is not resistant to changed software.		
Multiplicity	1		
Type	EcucBooleanParamDef		
Default value	-		
Post-Build Variant Value	false		
Value Configuration Class	Pre-compile time	X	VARIANT-PRE-COMPILE
	Link time	X	VARIANT-LINK-TIME
	Post-build time	-	
Scope / Dependency	scope: local		

SWS Item	[ECUC_NvM_00484]		
Parameter Name	NvMRomBlockDataAddress		
Parent Container	NvMBlockDescriptor		
Description	Defines the start address of the ROM block data. If not configured, no ROM block is available for the selected block management type.		
Multiplicity	0..1		
Type	EcucStringParamDef		
Default value	-		





Regular Expression	-		
Post-Build Variant Multiplicity	false		
Post-Build Variant Value	false		
Multiplicity Configuration Class	Pre-compile time	X	VARIANT-PRE-COMPILE
	Link time	X	VARIANT-LINK-TIME
	Post-build time	-	
Value Configuration Class	Pre-compile time	X	VARIANT-PRE-COMPILE
	Link time	X	VARIANT-LINK-TIME
	Post-build time	-	
Scope / Dependency	scope: local		

SWS Item	[ECUC_NvM_00485]		
Parameter Name	NvMRomBlockNum		
Parent Container	NvMBlockDescriptor		
Description	<p>Defines the number of multiple ROM blocks in a contiguous area according to the given block management type.</p> <p>0-254 For NVRAM blocks to be configured of block management type NVM_BLOCK_DATASET. The actual range is limited according to SWS_NvM_00444.</p> <p>0-1 For NVRAM blocks to be configured of block management type NVM_BLOCK_NATIVE</p> <p>0-1 For NVRAM blocks to be configured of block management type NVM_BLOCK_REDUNDANT</p>		
Multiplicity	1		
Type	EcucIntegerParamDef		
Range	0 .. 254		
Default value	-		
Post-Build Variant Value	false		
Value Configuration Class	Pre-compile time	X	VARIANT-PRE-COMPILE
	Link time	X	VARIANT-LINK-TIME
	Post-build time	-	
Scope / Dependency	scope: local dependency: NVM_BLOCK_MANAGEMENT_TYPE, NVM_NV_BLOCK_NUM		

SWS Item	[ECUC_NvM_00558]		
Parameter Name	NvMSelectBlockForFirstInitAll		
Parent Container	NvMBlockDescriptor		
Description	<p>Defines whether a block will be processed or not by NvM_FirstInitAll. A block can be configured to be processed even if it doesn't have permanent RAM and/or explicit synchronization.</p> <p>TRUE: block will be processed by NvM_FirstInitAll</p> <p>FALSE: block will not be processed by NvM_FirstInitAll</p>		
Multiplicity	0..1		
Type	EcucBooleanParamDef		
Default value	false		
Post-Build Variant Multiplicity	false		
Post-Build Variant Value	false		
Multiplicity Configuration Class	Pre-compile time	X	VARIANT-PRE-COMPILE
	Link time	X	VARIANT-LINK-TIME





	Post-build time	–	
Value Configuration Class	Pre-compile time	X	VARIANT-PRE-COMPILE
	Link time	X	VARIANT-LINK-TIME
	Post-build time	–	
Scope / Dependency	scope: local		

SWS Item	[ECUC_NvM_00117]		
Parameter Name	NvMSelectBlockForReadAll		
Parent Container	NvMBlockDescriptor		
Description	<p>Defines whether a NVRAM block shall be processed during NvM_ReadAll or not. This configuration parameter has only influence on those NVRAM blocks which are configured to have a permanent RAM block or which are configured to use explicit synchronization mechanism.</p> <p>true: NVRAM block shall be processed by NvM_ReadAll false: NVRAM block shall not be processed by NvM_ReadAll</p>		
Multiplicity	0..1		
Type	EcucBooleanParamDef		
Default value	–		
Post-Build Variant Multiplicity	false		
Post-Build Variant Value	false		
Multiplicity Configuration Class	Pre-compile time	X	VARIANT-PRE-COMPILE
	Link time	X	VARIANT-LINK-TIME
	Post-build time	–	
Value Configuration Class	Pre-compile time	X	VARIANT-PRE-COMPILE
	Link time	X	VARIANT-LINK-TIME
	Post-build time	–	
Scope / Dependency	scope: local dependency: NVM_RAM_BLOCK_DATA_ADDRESS		

SWS Item	[ECUC_NvM_00549]		
Parameter Name	NvMSelectBlockForWriteAll		
Parent Container	NvMBlockDescriptor		
Description	<p>Defines whether a NVRAM block shall be processed during NvM_WriteAll or not. This configuration parameter has only influence on those NVRAM blocks which are configured to have a permanent RAM block or which are configured to use explicit synchronization mechanism.</p> <p>true: NVRAM block shall be processed by NvM_WriteAll false: NVRAM block shall not be processed by NvM_WriteAll</p>		
Multiplicity	0..1		
Type	EcucBooleanParamDef		
Default value	–		
Post-Build Variant Multiplicity	false		
Post-Build Variant Value	false		
Multiplicity Configuration Class	Pre-compile time	X	VARIANT-PRE-COMPILE
	Link time	X	VARIANT-LINK-TIME
	Post-build time	–	
Value Configuration Class	Pre-compile time	X	VARIANT-PRE-COMPILE
	Link time	X	VARIANT-LINK-TIME
	Post-build time	–	





Scope / Dependency	scope: local dependency: NVM_RAM_BLOCK_DATA_ADDRESS
---------------------------	--

SWS Item	[ECUC_NvM_00532]		
Parameter Name	NvMStaticBlockIDCheck		
Parent Container	NvMBlockDescriptor		
Description	Defines if the Static Block ID check is enabled. false: Static Block ID check is disabled. true: Static Block ID check is enabled.		
Multiplicity	1		
Type	EcucBooleanParamDef		
Default value	false		
Post-Build Variant Value	false		
Value Configuration Class	Pre-compile time	X	VARIANT-PRE-COMPILE
	Link time	X	VARIANT-LINK-TIME
	Post-build time	–	
Scope / Dependency	scope: local		

SWS Item	[ECUC_NvM_00072]		
Parameter Name	NvMWriteBlockOnce		
Parent Container	NvMBlockDescriptor		
Description	Defines write protection after first write. The NVRAM manager sets the write protection bit either after the NV block was written the first time or if the block was already written and it is detected as valid and consistent during a read for it. true: Defines write protection after first write is enabled. false: Defines write protection after first write is disabled.		
Multiplicity	1		
Type	EcucBooleanParamDef		
Default value	–		
Post-Build Variant Value	false		
Value Configuration Class	Pre-compile time	X	VARIANT-PRE-COMPILE
	Link time	X	VARIANT-LINK-TIME
	Post-build time	–	
Scope / Dependency	scope: local		

SWS Item	[ECUC_NvM_00520]		
Parameter Name	NvMWriteRamBlockToNvCallback		
Parent Container	NvMBlockDescriptor		
Description	Entry address of a block specific callback routine which shall be called in order to let the application copy data from RAM block to NvM module's mirror. Implementation type: Std_ReturnType E_OK: copy was successful E_NOT_OK: copy was not successful, callback routine to be called again		
Multiplicity	0..1		
Type	EcucFunctionNameDef		
Default value	–		
Regular Expression	–		
Post-Build Variant Multiplicity	false		
Post-Build Variant Value	false		





Multiplicity Configuration Class	Pre-compile time	X	VARIANT-PRE-COMPILE
	Link time	X	VARIANT-LINK-TIME
	Post-build time	–	
Value Configuration Class	Pre-compile time	X	VARIANT-PRE-COMPILE
	Link time	X	VARIANT-LINK-TIME
	Post-build time	–	
Scope / Dependency	scope: local		

SWS Item	[ECUC_NvM_00534]		
Parameter Name	NvMWriteVerification		
Parent Container	NvMBlockDescriptor		
Description	Defines if Write Verification is enabled. false: Write verification is disabled. true: Write Verification is enabled.		
Multiplicity	1		
Type	EcucBooleanParamDef		
Default value	false		
Post-Build Variant Value	false		
Value Configuration Class	Pre-compile time	X	VARIANT-PRE-COMPILE
	Link time	X	VARIANT-LINK-TIME
	Post-build time	–	
Scope / Dependency	scope: local		

SWS Item	[ECUC_NvM_00538]		
Parameter Name	NvMWriteVerificationDataSize		
Parent Container	NvMBlockDescriptor		
Description	Defines the number of bytes to compare in each step when comparing the content of a RAM Block and a block read back.		
Multiplicity	1		
Type	EcucIntegerParamDef		
Range	1 .. 65535		
Default value	–		
Post-Build Variant Value	false		
Value Configuration Class	Pre-compile time	X	VARIANT-PRE-COMPILE
	Link time	X	VARIANT-LINK-TIME
	Post-build time	–	
Scope / Dependency	scope: local		

SWS Item	[ECUC_NvM_00567]		
Parameter Name	NvMBlockCipherringRef		
Parent Container	NvMBlockDescriptor		
Description	Reference to cipherring container. If configured, NvM encrypt the data before storage and decrypt the data after restoring. If empty, the NvM stores and restore the original user data. Tags: atp.Status=draft		
Multiplicity	0..1		
Type	Reference to NvMBlockCipherring		
Post-Build Variant Multiplicity	false		





Post-Build Variant Value	false		
Multiplicity Configuration Class	Pre-compile time	X	All Variants
	Link time	–	
	Post-build time	–	
Value Configuration Class	Pre-compile time	X	All Variants
	Link time	–	
	Post-build time	–	
Scope / Dependency	scope: local dependency: Key will be located in RAM if this configuration item is not present.		

SWS Item	[ECUC_NvM_00564]		
Parameter Name	NvMBlockEcucPartitionRef		
Parent Container	NvMBlockDescriptor		
Description	Maps the NV block to zero or one ECUC partition to limit the access to this NV block. The ECUC partition referenced is within the subset of the ECUC partitions where the NvM is mapped to.		
Multiplicity	0..1		
Type	Reference to EcucPartition		
Value Configuration Class	Pre-compile time	X	All Variants
	Link time	–	
	Post-build time	–	
Scope / Dependency	scope: ECU		

Included Containers		
Container Name	Multiplicity	Scope / Dependency
NvMInitBlockCallback	0..1	<p>The presence of this container indicates, that a block specific callback routine is called if no ROM data is available for initialization of the NVRAM block. If the container is not present, no callback routine is called for initialization of the NVRAM block with default data.</p> <p>In case the container has a NvMInitBlockCallbackFnc, the NvM will call this function.</p> <p>In case there is no NvMInitBlockCallbackFnc, the NvM will have an port PNIB_{Block}.</p>
NvMSingleBlockCallback	0..1	<p>The presence of this container indicates, that the block specific callback routine which shall be invoked on termination of each asynchronous single block request [SWS_NvM_00113] If the container is not present, no callback routine is called..</p> <p>In case the container has a NvMSingleBlockCallbackFnc, the NvM will call this function.</p> <p>In case there is no NvMSingleBlockCallbackFnc, the NvM will have an port PNJF_{Block}.</p>
NvMTargetBlockReference	1	This parameter is just a container for the parameters for EA and FEE

C.4.2 NvMInitBlockCallback

SWS Item	[ECUC_NvM_00561]		
Container Name	NvMInitBlockCallback		
Parent Container	NvMBlockDescriptor		
Description	<p>The presence of this container indicates, that a block specific callback routine is called if no ROM data is available for initialization of the NVRAM block. If the container is not present, no callback routine is called for initialization of the NVRAM block with default data.</p> <p>In case the container has a NvMInitBlockCallbackFnc, the NvM will call this function.</p> <p>In case there is no NvMInitBlockCallbackFnc, the NvM will have an port PNIB_{Block}.</p>		
Multiplicity Configuration Class	Pre-compile time	X	VARIANT-PRE-COMPILE
	Link time	X	VARIANT-LINK-TIME
	Post-build time	–	
Configuration Parameters			

SWS Item	[ECUC_NvM_00116]		
Parameter Name	NvMInitBlockCallbackFnc		
Parent Container	NvMInitBlockCallback		
Description	<p>Entry address of a block specific callback routine which shall be called if no ROM data is available for initialization of the NVRAM block.</p> <p>If not configured, no specific callback routine shall be called for initialization of the NVRAM block with default data.</p>		
Multiplicity	0..1		
Type	EcucFunctionNameDef		
Default value	–		
Regular Expression	–		
Post-Build Variant Multiplicity	false		
Post-Build Variant Value	false		
Multiplicity Configuration Class	Pre-compile time	X	VARIANT-PRE-COMPILE
	Link time	X	VARIANT-LINK-TIME
	Post-build time	–	
Value Configuration Class	Pre-compile time	X	VARIANT-PRE-COMPILE
	Link time	X	VARIANT-LINK-TIME
	Post-build time	–	
Scope / Dependency	scope: local		

No Included Containers

C.4.3 NvMSingleBlockCallback

SWS Item	[ECUC_NvM_00562]		
Container Name	NvMSingleBlockCallback		
Parent Container	NvMBlockDescriptor		





Description	The presence of this container indicates, that the block specific callback routine which shall be invoked on termination of each asynchronous single block request [SWS_NvM_00113] If the container is not present, no callback routine is called.. In case the container has a NvMSingleBlockCallbackFnc, the NvM will call this function. In case there is no NvMSingleBlockCallbackFnc, the NvM will have an port PNJF_{Block}.		
Multiplicity Configuration Class	Pre-compile time	X	VARIANT-PRE-COMPILE
	Link time	X	VARIANT-LINK-TIME
	Post-build time	–	
Configuration Parameters			

SWS Item	[ECUC_NvM_00506]		
Parameter Name	NvMSingleBlockCallbackFnc		
Parent Container	NvMSingleBlockCallback		
Description	Entry address of the block specific callback routine which shall be invoked on termination of each asynchronous single block request [SWS_NvM_00113].		
Multiplicity	0..1		
Type	EcucFunctionNameDef		
Default value	–		
Regular Expression	–		
Post-Build Variant Multiplicity	false		
Post-Build Variant Value	false		
Multiplicity Configuration Class	Pre-compile time	X	VARIANT-PRE-COMPILE
	Link time	X	VARIANT-LINK-TIME
	Post-build time	–	
Value Configuration Class	Pre-compile time	X	VARIANT-PRE-COMPILE
	Link time	X	VARIANT-LINK-TIME
	Post-build time	–	
Scope / Dependency	scope: local		

No Included Containers

C.5 Dcm

C.5.1 DcmDspDid

SWS Item	[ECUC_Dcm_00601]
Container Name	DcmDspDid
Parent Container	DcmDsp
Description	This container contains the configuration (parameters) of the DID.
Configuration Parameters	

SWS Item	[ECUC_Dcm_00602]		
Parameter Name	DcmDspDidIdentifier		
Parent Container	DcmDspDid		
Description	2 byte Identifier of the DID Within each DcmConfigSet all DcmDspDidIdentifier values shall be unique.		
Multiplicity	1		
Type	EcucIntegerParamDef		
Range	0 .. 65535		
Default value	–		
Post-Build Variant Value	false		
Value Configuration Class	Pre-compile time	X	VARIANT-PRE-COMPILE, VARIANT-POST-BUILD
	Link time	X	VARIANT-LINK-TIME
	Post-build time	–	
Scope / Dependency	scope: ECU		

SWS Item	[ECUC_Dcm_01099]		
Parameter Name	DcmDspDidSize		
Parent Container	DcmDspDid		
Description	Length of a DID in byte(s).		
Multiplicity	0..1		
Type	EcucIntegerParamDef		
Range	0 .. 65535		
Default value	–		
Post-Build Variant Value	false		
Value Configuration Class	Pre-compile time	X	VARIANT-PRE-COMPILE, VARIANT-POST-BUILD
	Link time	X	VARIANT-LINK-TIME
	Post-build time	–	
Scope / Dependency	scope: ECU		

SWS Item	[ECUC_Dcm_00805]		
Parameter Name	DcmDspDidUsed		
Parent Container	DcmDspDid		
Description	Allow to activate or deactivate the usage of a DID, for multi purpose ECUs true = DID available false = DID not available		
Multiplicity	1		
Type	EcucBooleanParamDef		
Default value	–		
Post-Build Variant Value	true		
Value Configuration Class	Pre-compile time	X	VARIANT-PRE-COMPILE
	Link time	X	VARIANT-LINK-TIME
	Post-build time	X	VARIANT-POST-BUILD
Scope / Dependency	scope: ECU		

SWS Item	[ECUC_Dcm_01122]		
Parameter Name	DcmDspDidUsePort		
Parent Container	DcmDspDid		
Description	Selects application interface type for DID data elements between a single operation for all data elements or data element specific operations.		
Multiplicity	1		
Type	EcucEnumerationParamDef		
Range	USE_ATOMIC_BNDM	The DID shall be read/written from/to BndM.	
	USE_ATOMIC_NV_DATA_INTERFACE	A single sender receiver interface with Nv Data-Ports is used for all data elements of this DID.	
	USE_ATOMIC_SENDER_RECEIVER_INTERFACE	A single sender receiver interface is used to access all data elements of this DID. The sender receiver interface is typed with IsService=false.	
	USE_ATOMIC_SENDER_RECEIVER_INTERFACE_AS_SERVICE	A single sender receiver interface is used to access all data elements of this DID. The sender receiver interface is typed with IsService=true.	
	USE_DATA_ELEMENT_SPECIFIC_INTERFACES	The data elements of this DID are collected by using the data element specific interfaces defined by DcmDspDataUsePort.	
Default value	USE_DATA_ELEMENT_SPECIFIC_INTERFACES		
Post-Build Variant Value	false		
Value Configuration Class	Pre-compile time	X	All Variants
	Link time	–	
	Post-build time	–	
Scope / Dependency			

SWS Item	[ECUC_Dcm_01185]		
Parameter Name	DcmDspDidBndMBlockIdRef		
Parent Container	DcmDspDid		
Description	Associate this DID with a BndM blockId.		
Multiplicity	0..1		
Type	Symbolic name reference to BndMBlockDescriptor		
Post-Build Variant Multiplicity	false		
Post-Build Variant Value	false		
Multiplicity Configuration Class	Pre-compile time	X	All Variants
	Link time	–	
	Post-build time	–	
Value Configuration Class	Pre-compile time	X	All Variants
	Link time	–	
	Post-build time	–	
Scope / Dependency	scope: ECU dependency: DcmDspDidUsePort == USE_ATOMIC_BNDM		

SWS Item	[ECUC_Dcm_00604]		
Parameter Name	DcmDspDidInfoRef		
Parent Container	DcmDspDid		
Description	Reference to DcmDspDidInfo containing information on this DID.		
Multiplicity	1		





Type	Reference to DcmDspDidInfo		
Post-Build Variant Value	false		
Value Configuration Class	Pre-compile time	X	VARIANT-PRE-COMPILE, VARIANT-POST-BUILD
	Link time	X	VARIANT-LINK-TIME
	Post-build time	–	
Scope / Dependency	scope: ECU		

SWS Item	[ECUC_Dcm_00606]		
Parameter Name	DcmDspDidRef		
Parent Container	DcmDspDid		
Description	Reference to DcmDspDid in case this DID refer to one or several other DID's Attributes: requiresIndex=true		
Multiplicity	0..*		
Type	Reference to DcmDspDid		
Post-Build Variant Multiplicity	false		
Post-Build Variant Value	false		
Multiplicity Configuration Class	Pre-compile time	X	VARIANT-PRE-COMPILE, VARIANT-POST-BUILD
	Link time	X	VARIANT-LINK-TIME
	Post-build time	–	
Value Configuration Class	Pre-compile time	X	VARIANT-PRE-COMPILE, VARIANT-POST-BUILD
	Link time	X	VARIANT-LINK-TIME
	Post-build time	–	
Scope / Dependency	scope: ECU		

Included Containers		
Container Name	Multiplicity	Scope / Dependency
DcmDspDidSignal	0..*	This container defines the reference to 1 DcmDspData container and position relevant for this DID.
DcmDspDidSignalCompositePool	0..*	Defines a collection of all contained signals for this root signal.
DcmDspDidSupportInfo	0..1	This container defines the support information to declare the usability of the data bytes within the DIDs

C.5.2 DcmDspDidInfo

SWS Item	[ECUC_Dcm_00607]
Container Name	DcmDspDidInfo
Parent Container	DcmDsp
Description	This container contains the configuration (parameters) of the DID's Info
Configuration Parameters	

SWS Item	[ECUC_Dcm_00970]		
Parameter Name	DcmDspDDDIDMaxElements		
Parent Container	DcmDspDidInfo		
Description	Maximum number of source elements of a DDDID.		
Multiplicity	0..1		
Type	EcucIntegerParamDef		
Range	1 .. 255		
Default value	–		
Post-Build Variant Multiplicity	false		
Post-Build Variant Value	false		
Multiplicity Configuration Class	Pre-compile time	X	VARIANT-PRE-COMPILE, VARIANT-POST-BUILD
	Link time	X	VARIANT-LINK-TIME
	Post-build time	–	
Value Configuration Class	Pre-compile time	X	VARIANT-PRE-COMPILE, VARIANT-POST-BUILD
	Link time	X	VARIANT-LINK-TIME
	Post-build time	–	
Scope / Dependency	scope: local		

SWS Item	[ECUC_Dcm_00612]		
Parameter Name	DcmDspDidDynamicallyDefined		
Parent Container	DcmDspDidInfo		
Description	Indicates if this DID can be dynamically defined true = DID can be dynamically defined false = DID can not be dynamically defined		
Multiplicity	1		
Type	EcucBooleanParamDef		
Default value	–		
Post-Build Variant Value	false		
Value Configuration Class	Pre-compile time	X	VARIANT-PRE-COMPILE, VARIANT-POST-BUILD
	Link time	X	VARIANT-LINK-TIME
	Post-build time	–	
Scope / Dependency	scope: ECU		

Included Containers		
Container Name	Multiplicity	Scope / Dependency
DcmDspDidControl	0..1	This container contains the configuration (parameters) of the DID control.
DcmDspDidRead	0..1	This container contains the configuration (parameters) of the DID read.
DcmDspDidWrite	0..1	This container contains the configuration (parameters) of the DID write.

C.5.3 DcmDspData

SWS Item	[ECUC_Dcm_00869]
Container Name	DcmDspData
Parent Container	DcmDsp
Description	This container contains the configuration (parameters) of a Data belonging to a DID
Configuration Parameters	

SWS Item	[ECUC_Dcm_01106]		
Parameter Name	DcmDspDataByteSize		
Parent Container	DcmDspData		
Description	Defines the array length in bytes or the the maximum array length for variable datalengths.		
Multiplicity	0..1		
Type	EcucIntegerParamDef		
Range	0 .. 65535		
Default value	-		
Post-Build Variant Multiplicity	false		
Post-Build Variant Value	false		
Multiplicity Configuration Class	Pre-compile time	X	VARIANT-PRE-COMPILE, VARIANT-POST-BUILD
	Link time	X	VARIANT-LINK-TIME
	Post-build time	-	
Value Configuration Class	Pre-compile time	X	VARIANT-PRE-COMPILE, VARIANT-POST-BUILD
	Link time	X	VARIANT-LINK-TIME
	Post-build time	-	
Scope / Dependency	scope: ECU		

SWS Item	[ECUC_Dcm_00677]		
Parameter Name	DcmDspDataConditionCheckReadFnc		
Parent Container	DcmDspData		
Description	Function name to demand application if the conditions (e.g. System state) to read the DID are correct. (ConditionCheckRead-function). Multiplicity shall be equal to parameter DcmDspDataReadFnc. This parameter is related to the interface Xxx_ConditionCheckRead.		
Multiplicity	0..1		
Type	EcucFunctionNameDef		
Default value	-		
Regular Expression	-		
Post-Build Variant Multiplicity	false		
Post-Build Variant Value	false		
Multiplicity Configuration Class	Pre-compile time	X	All Variants
	Link time	-	
	Post-build time	-	
Value Configuration Class	Pre-compile time	X	All Variants
	Link time	-	
	Post-build time	-	
Scope / Dependency	scope: ECU		

SWS Item	[ECUC_Dcm_00955]		
Parameter Name	DcmDspDataConditionCheckReadFncUsed		
Parent Container	DcmDspData		
Description	This parameter determines if a condition check function is available or not.		
Multiplicity	0..1		
Type	EcucBooleanParamDef		
Default value	-		
Post-Build Variant Multiplicity	false		
Post-Build Variant Value	false		
Multiplicity Configuration Class	Pre-compile time	X	All Variants
	Link time	-	
	Post-build time	-	
Value Configuration Class	Pre-compile time	X	All Variants
	Link time	-	
	Post-build time	-	
Scope / Dependency	scope: local		

SWS Item	[ECUC_Dcm_00825]		
Parameter Name	DcmDspDataEcuSignal		
Parent Container	DcmDspData		
Description	Function name to control the access to a certain ECU Signal by the DCM. (IoHwAb_Dcm_<symbolic name of ECU signal>-function).		
Multiplicity	0..1		
Type	EcucFunctionNameDef		
Default value	-		
Regular Expression	-		
Post-Build Variant Multiplicity	false		
Post-Build Variant Value	false		
Multiplicity Configuration Class	Pre-compile time	X	All Variants
	Link time	-	
	Post-build time	-	
Value Configuration Class	Pre-compile time	X	All Variants
	Link time	-	
	Post-build time	-	
Scope / Dependency	scope: ECU		

SWS Item	[ECUC_Dcm_00986]		
Parameter Name	DcmDspDataEndianness		
Parent Container	DcmDspData		
Description	Defines the endianness of the data belonging to a DID in a diagnostic request or response message.		
Multiplicity	0..1		
Type	EcucEnumerationParamDef		
Range	BIG_ENDIAN	Most significant byte shall be stored at the lowest address.	
	LITTLE_ENDIAN	Most significant byte shall be stored at the highest address.	
	OPAQUE	Opaque data endianness	





Post-Build Variant Multiplicity	false		
Post-Build Variant Value	false		
Multiplicity Configuration Class	Pre-compile time	X	VARIANT-PRE-COMPILE, VARIANT-POST-BUILD
	Link time	X	VARIANT-LINK-TIME
	Post-build time	–	
Value Configuration Class	Pre-compile time	X	VARIANT-PRE-COMPILE, VARIANT-POST-BUILD
	Link time	X	VARIANT-LINK-TIME
	Post-build time	–	
Scope / Dependency	scope: local		

SWS Item	[ECUC_Dcm_00674]		
Parameter Name	DcmDspDataFreezeCurrentStateFnc		
Parent Container	DcmDspData		
Description	Function name to request to application to freeze the current state of an IOControl. (FreezeCurrentState-function). This parameter is related to the interface Xxx_FreezeCurrentState.		
Multiplicity	0..1		
Type	EcucFunctionNameDef		
Default value	–		
Regular Expression	–		
Post-Build Variant Multiplicity	false		
Post-Build Variant Value	false		
Multiplicity Configuration Class	Pre-compile time	X	All Variants
	Link time	–	
	Post-build time	–	
Value Configuration Class	Pre-compile time	X	All Variants
	Link time	–	
	Post-build time	–	
Scope / Dependency	scope: ECU		

SWS Item	[ECUC_Dcm_00676]		
Parameter Name	DcmDspDataGetScalingInfoFnc		
Parent Container	DcmDspData		
Description	Function name to request to application the scaling information of the DID. (GetScaling Information-function). This parameter is related to the interface Xxxx_GetScaling Information.		
Multiplicity	0..1		
Type	EcucFunctionNameDef		
Default value	–		
Regular Expression	–		
Post-Build Variant Multiplicity	false		
Post-Build Variant Value	false		
Multiplicity Configuration Class	Pre-compile time	X	All Variants
	Link time	–	
	Post-build time	–	
Value Configuration Class	Pre-compile time	X	All Variants





	Link time	–	
	Post-build time	–	
Scope / Dependency	scope: ECU		

SWS Item	[ECUC_Dcm_00671]		
Parameter Name	DcmDspDataReadDataLengthFnc		
Parent Container	DcmDspData		
Description	Function name to request from application the data length of a DID. (ReadDataLength-function). This parameter is related to the interface Xxx_ReadDataLength.		
Multiplicity	0..1		
Type	EcucFunctionNameDef		
Default value	–		
Regular Expression	–		
Post-Build Variant Multiplicity	false		
Post-Build Variant Value	false		
Multiplicity Configuration Class	Pre-compile time	X	All Variants
	Link time	–	
	Post-build time	–	
Value Configuration Class	Pre-compile time	X	All Variants
	Link time	–	
	Post-build time	–	
Scope / Dependency	scope: ECU		

SWS Item	[ECUC_Dcm_00824]		
Parameter Name	DcmDspDataReadEcuSignal		
Parent Container	DcmDspData		
Description	Function name for read access to a certain ECU Signal by the DCM. (IoHwAb_Dcm_Read<EcuSignalName>-function). Only relevant if DcmDspDataUsePort==USE_ECU_SIGNAL.		
Multiplicity	0..1		
Type	EcucFunctionNameDef		
Default value	–		
Regular Expression	–		
Post-Build Variant Multiplicity	false		
Post-Build Variant Value	false		
Multiplicity Configuration Class	Pre-compile time	X	All Variants
	Link time	–	
	Post-build time	–	
Value Configuration Class	Pre-compile time	X	All Variants
	Link time	–	
	Post-build time	–	
Scope / Dependency	scope: ECU		

SWS Item	[ECUC_Dcm_00669]		
Parameter Name	DcmDspDataReadFnc		
Parent Container	DcmDspData		





Description	Function name to request from application the data value of a DID. (Read Data-function). This parameter is related to the interface Xxx_ReadData.		
Multiplicity	0..1		
Type	EcucFunctionNameDef		
Default value	–		
Regular Expression	–		
Post-Build Variant Multiplicity	false		
Post-Build Variant Value	false		
Multiplicity Configuration Class	Pre-compile time	X	All Variants
	Link time	–	
	Post-build time	–	
Value Configuration Class	Pre-compile time	X	All Variants
	Link time	–	
	Post-build time	–	
Scope / Dependency	scope: local		

SWS Item	[ECUC_Dcm_00673]		
Parameter Name	DcmDspDataResetToDefaultFnc		
Parent Container	DcmDspData		
Description	Function name to request to application to reset an IOControl to default value. (Reset ToDefault-function). This parameter is related to the interface Xxx_ResetToDefault.		
Multiplicity	0..1		
Type	EcucFunctionNameDef		
Default value	–		
Regular Expression	–		
Post-Build Variant Multiplicity	false		
Post-Build Variant Value	false		
Multiplicity Configuration Class	Pre-compile time	X	All Variants
	Link time	–	
	Post-build time	–	
Value Configuration Class	Pre-compile time	X	All Variants
	Link time	–	
	Post-build time	–	
Scope / Dependency	scope: ECU		

SWS Item	[ECUC_Dcm_00672]		
Parameter Name	DcmDspDataReturnControlToEcuFnc		
Parent Container	DcmDspData		
Description	Function name to request to application to return control to ECU of an IOControl. (ReturnControlToECU-function). This parameter is related to the interface Xxx_ReturnControlToECU.		
Multiplicity	0..1		
Type	EcucFunctionNameDef		
Default value	–		
Regular Expression	–		
Post-Build Variant Multiplicity	false		
Post-Build Variant Value	false		
Multiplicity Configuration Class	Pre-compile time	X	All Variants





	Link time	–	
	Post-build time	–	
Value Configuration Class	Pre-compile time	X	All Variants
	Link time	–	
	Post-build time	–	
Scope / Dependency	scope: ECU		

SWS Item	[ECUC_Dcm_00675]		
Parameter Name	DcmDspDataShortTermAdjustmentFnc		
Parent Container	DcmDspData		
Description	Function name to request to application to adjust the IO signal. (ShortTerm Adjustment-function). This parameter is related to the interface Xxx_ShortTermAdjustment.		
Multiplicity	0..1		
Type	EcucFunctionNameDef		
Default value	–		
Regular Expression	–		
Post-Build Variant Multiplicity	false		
Post-Build Variant Value	false		
Multiplicity Configuration Class	Pre-compile time	X	All Variants
	Link time	–	
	Post-build time	–	
Value Configuration Class	Pre-compile time	X	All Variants
	Link time	–	
	Post-build time	–	
Scope / Dependency	scope: ECU		

SWS Item	[ECUC_Dcm_00985]	
Parameter Name	DcmDspDataType	
Parent Container	DcmDspData	
Description	Provide the implementation data type of data belonging to a DID.	
Multiplicity	1	
Type	EcucEnumerationParamDef	
Range	BOOLEAN	Type of the data is boolean.
	FLOAT	Type of the data is float.
	FLOAT_N	Type of the data is float array.
	SINT16	Type of the data is sint16.
	SINT16_N	Type of the data is sint16 array.
	SINT32	Type of the data is sint32.
	SINT32_N	Type of the data is sint32 array.
	SINT8	Type of the data is sint8.
	SINT8_N	Type of the data is sint8 array.
	UINT16	Type of the data is uint16.
	UINT16_N	Type of the data is uint16 array.
	UINT32	Type of the data is uint32.
	UINT32_N	Type of the data is uint32 array.





	UINT8	Type of the data is uint8.	
	UINT8_DYN	Type of the data is uint8 array with dynamic length.	
	UINT8_N	Type of the data is uint8 array.	
Post-Build Variant Value	false		
Value Configuration Class	Pre-compile time	X	VARIANT-PRE-COMPILE, VARIANT-POST-BUILD
	Link time	X	VARIANT-LINK-TIME
	Post-build time	–	
Scope / Dependency	scope: ECU		

SWS Item	[ECUC_Dcm_00713]		
Parameter Name	DcmDspDataUsePort		
Parent Container	DcmDspData		
Description	Defines which interface shall be used to access the data.		
Multiplicity	1		
Type	EcucEnumerationParamDef		
Range	USE_BLOCK_ID	The DCM will access the Data using the NVRAM Apis with the BlockId defined in DcmDspData BlockId	
	USE_DATA_ASYNC_CLIENT_SERVER	The DCM will access the Data using an R-Port requiring a asynchronous ClientServerInterface DataServices_{Data}. The R-Port is named Data Services_{Data} where {Data} is the name of the container DcmDspData.	
	USE_DATA_ASYNC_CLIENT_SERVER_ERROR	The Dcm will access the Data using an R-Port requiring a asynchronous ClientServerInterface DataServices_{Data}. The parameter ErrorCode can be returned to allow the application to trigger a negative response during the operation. The R-Port is named DataServices_{Data} where {Data} is the name of the container DcmDspData.	
	USE_DATA_ASYNC_FNC	The DCM will access the Data using the functions that are defined in parameters of type EcucFunctionNameDef (but without DcmDsp DataReadDataLengthFnc) in the DcmDspData container. DCM_E_PENDING return is allowed. OpStatus is existing as IN parameter.	
	USE_DATA_ASYNC_FNC_ERROR	The DCM will access the Data using the functions that are defined in parameters of type EcucFunctionNameDef (but without DcmDsp DataReadDataLengthFnc) in the DcmDspData container. DCM_E_PENDING return is allowed. OpStatus is existing as IN parameter. The parameter ErrorCode can be returned to allow the application to trigger a negative response during the operation.	
	USE_DATA_ASYNC_FNC_PROXY	The DCM will access the Data using the functions that are defined in parameters of type EcucFunctionNameDef (with DataLength and ErrorCode parameter). DCM_E_PENDING return is allowed. OpStatus is existing as IN parameter. Tags: atp.Status=draft	





	USE_DATA_SENDER_RECEIVER	The DCM will access the Data using an Port requiring a SenderReceiverInterface (with is Service=false) DataServices_{Data}. The Port is namedDataServices_{Data} where {Data} is the name of the container DcmDspData.	
	USE_DATA_SENDER_RECEIVER_AS_SERVICE	The DCM will access the Data using an service Port requiring a SenderReceiverInterface (with is Service=true) DataServices_{Data} . The Port is namedDataServices_{Data} where {Data} is the name of the container DcmDspData.	
	USE_DATA_SYNCH_CLIENT_SERVER	The DCM will access the Data using an R-Port requiring a synchronous ClientServerInterface DataServices_{Data}. The R-Port is named Data Services_{Data} where {Data} is the name of the container DcmDspData.	
	USE_DATA_SYNCH_FNC	The DCM will access the Data using the functions that are defined in parameters of type EcucFunctionNameDef (but without DcmDsp DataReadDataLengthFnc) in the DcmDspData container. DCM_E_PENDING return value is not allowed and OpStatus parameter is not existing in the prototype.	
	USE_DATA_SYNCH_FNC_PROXY	The DCM will access the Data using the functions that are defined in parameters of type EcucFunctionNameDef (with DataLength and ErrorCode parameter). DCM_E_PENDING return value is not allowed and OpStatus parameter is not existing in the prototype. Tags: atp.Status=draft	
	USE_ECU_SIGNAL	The DCM will access the Data using a direct access to IoHwAb	
Post-Build Variant Value	false		
Value Configuration Class	Pre-compile time	X	All Variants
	Link time	–	
	Post-build time	–	
Scope / Dependency	scope: ECU		

SWS Item	[ECUC_Dcm_00670]		
Parameter Name	DcmDspDataWriteFnc		
Parent Container	DcmDspData		
Description	Function name to request application to write the data value of a DID. (Write Data-function). This parameter is related to the interface Xxx_WriteData.		
Multiplicity	0..1		
Type	EcucFunctionNameDef		
Default value	–		
Regular Expression	–		
Post-Build Variant Multiplicity	false		
Post-Build Variant Value	false		
Multiplicity Configuration Class	Pre-compile time	X	All Variants
	Link time	–	
	Post-build time	–	
Value Configuration Class	Pre-compile time	X	All Variants
	Link time	–	
	Post-build time	–	





Scope / Dependency	scope: ECU		
SWS Item	[ECUC_Dcm_00988]		
Parameter Name	DcmDspOdxDataDescription		
Parent Container	DcmDspData		
Description	Defines additional description for ODX documentation		
Multiplicity	0..1		
Type	EcucAddInfoParamDef		
Default value	-		
Post-Build Variant Multiplicity	false		
Post-Build Variant Value	false		
Multiplicity Configuration Class	Pre-compile time	X	All Variants
	Link time	-	
	Post-build time	-	
Value Configuration Class	Pre-compile time	X	All Variants
	Link time	-	
	Post-build time	-	
Scope / Dependency	scope: local		

SWS Item	[ECUC_Dcm_00809]		
Parameter Name	DcmDspDataBlockIdRef		
Parent Container	DcmDspData		
Description	NRAM blockId to access the data. Only relevant if DcmDspDataUsePort==USE_BLOCK_ID.		
Multiplicity	0..1		
Type	Symbolic name reference to NvMBlockDescriptor		
Post-Build Variant Multiplicity	false		
Post-Build Variant Value	false		
Multiplicity Configuration Class	Pre-compile time	X	All Variants
	Link time	-	
	Post-build time	-	
Value Configuration Class	Pre-compile time	X	All Variants
	Link time	-	
	Post-build time	-	
Scope / Dependency	scope: ECU		

SWS Item	[ECUC_Dcm_00811]		
Parameter Name	DcmDspDataInfoRef		
Parent Container	DcmDspData		
Description	Reference to 1 DcmDspDataInfo		
Multiplicity	0..1		
Type	Reference to DcmDspDataInfo		
Post-Build Variant Value	false		
Value Configuration Class	Pre-compile time	X	All Variants
	Link time	-	
	Post-build time	-	





Scope / Dependency	scope: ECU
---------------------------	------------

Included Containers		
Container Name	Multiplicity	Scope / Dependency
DcmDspDiagnosisScaling	0..1	This container contains the configuration (parameters) of an alternative Diagnosis Representation. Out if this the scaling between Diagnosis and ECU internal representation and vice versa can be calculated.
DcmDspDidDataSupportInfo	0..1	This container defines the supported information.
DcmDspExternalSRDataElement Class	0..1	This container defines the source of data in a provided port which shall be read respectively the target of data in a required port which shall be written. This container shall contain either one DcmSubElementInData ElementInstance OR DcmDataElementInstance OR DcmSub ElementInImplDataElementInstance reference.

C.5.4 DcmDspDataInfo

SWS Item	[ECUC_Dcm_00810]
Container Name	DcmDspDataInfo
Parent Container	DcmDsp
Description	This container contains the configuration (parameters) of one Data.
Configuration Parameters	

SWS Item	[ECUC_Dcm_00611]		
Parameter Name	DcmDspDataScalingInfoSize		
Parent Container	DcmDspDataInfo		
Description	If Scaling information service is available for this Data, it provides the size in bytes of the scaling information.		
Multiplicity	0..1		
Type	EcuIntegerParamDef		
Range	0 .. 4294967295		
Default value	-		
Post-Build Variant Multiplicity	false		
Post-Build Variant Value	false		
Multiplicity Configuration Class	Pre-compile time	X	VARIANT-PRE-COMPILE, VARIANT-POST-BUILD
	Link time	X	VARIANT-LINK-TIME
	Post-build time	-	
Value Configuration Class	Pre-compile time	X	VARIANT-PRE-COMPILE, VARIANT-POST-BUILD
	Link time	X	VARIANT-LINK-TIME
	Post-build time	-	
Scope / Dependency	scope: ECU		

No Included Containers

C.5.5 DcmDspPidService01

SWS Item	[ECUC_Dcm_00894]
Container Name	DcmDspPidService01
Parent Container	DcmDspPidData
Description	Contains specific configuration parameter of PID for service \$01. This container exists only if DcmDspPidService is set to DCM_SERVICE_01 or DCM_SERVICE_01_02.
Configuration Parameters	

SWS Item	[ECUC_Dcm_01012]		
Parameter Name	DcmDspPidDataEndianness		
Parent Container	DcmDspPidService01		
Description	Defines the endianness of the data belonging to a PID in a diagnostic response message. If no DcmDspPidDataEndianness is defined the value of DcmDspDataDefault Endianness is applicable.		
Multiplicity	0..1		
Type	EcucEnumerationParamDef		
Range	BIG_ENDIAN	Most significant byte shall be stored at the lowest address.	
	LITTLE_ENDIAN	Most significant byte shall be stored at the highest address	
	OPAQUE	Opaque data endianness	
Post-Build Variant Multiplicity	false		
Post-Build Variant Value	false		
Multiplicity Configuration Class	Pre-compile time	X	All Variants
	Link time	–	
	Post-build time	–	
Value Configuration Class	Pre-compile time	X	All Variants
	Link time	–	
	Post-build time	–	
Scope / Dependency	scope: ECU		

SWS Item	[ECUC_Dcm_00629]		
Parameter Name	DcmDspPidDataReadFnc		
Parent Container	DcmDspPidService01		
Description	Function name for reading PID data value. This is only relevant if DcmDspPidDataUse Port==USE_DATA_SYNCH_FNC. This parameter is related to the interface Xxx_ReadData.		
Multiplicity	0..1		
Type	EcucFunctionNameDef		
Default value	–		
Regular Expression	–		
Post-Build Variant Multiplicity	false		
Post-Build Variant Value	false		
Multiplicity Configuration Class	Pre-compile time	X	All Variants
	Link time	–	
	Post-build time	–	
Value Configuration Class	Pre-compile time	X	All Variants





	Link time	–	
	Post-build time	–	
Scope / Dependency	scope: ECU		

SWS Item	[ECUC_Dcm_01018]		
Parameter Name	DcmDspPidDataType		
Parent Container	DcmDspPidService01		
Description	Provide the implementation data type of data belonging to a PID.		
Multiplicity	1		
Type	EcucEnumerationParamDef		
Range	BOOLEAN		Type of the data is boolean.
	SINT16		Type of the data is sint16.
	SINT16_N		Type of the data is sint16 array.
	SINT32		Type of the data is sint32.
	SINT32_N		Type of the data is sint32 array.
	SINT8		Type of the data is sint8.
	SINT8_N		Type of the data is sint8 array.
	UINT16		Type of the data is uint16.
	UINT16_N		Type of the data is uint16 array.
	UINT32		Type of the data is uint32.
	UINT32_N		Type of the data is uint32 array.
	UINT8		Type of the data is uint8.
	UINT8_N		Type of the data is uint8 array.
Post-Build Variant Multiplicity	false		
Post-Build Variant Value	false		
Multiplicity Configuration Class	Pre-compile time	X	VARIANT-PRE-COMPILE, VARIANT-POST-BUILD
	Link time	X	VARIANT-LINK-TIME
	Post-build time	–	
Value Configuration Class	Pre-compile time	X	VARIANT-PRE-COMPILE, VARIANT-POST-BUILD
	Link time	X	VARIANT-LINK-TIME
	Post-build time	–	
Scope / Dependency	scope: ECU		

SWS Item	[ECUC_Dcm_00720]		
Parameter Name	DcmDspPidDataUsePort		
Parent Container	DcmDspPidService01		
Description	<p>If this parameter is set to USE_DATA_SYNCH_FNC, the Dcm will use the function defined in DcmDspPidDataReadFnc to get the PID data value.</p> <p>If this parameter is set to USE_DATA_SYNCH_CLIENT_SERVER, the Dcm will have an R-Port requiring the interface DataServices_{Data}.</p> <p>If this parameter is set to USE_DATA_SENDER_RECEIVER or USE_DATA_SENDER_RECEIVER_AS_SERVICE, the DCM will have an R-Port requiring a SenderReceiver Interface.</p> <p>The R-Port is named DataServices_{Data} where {Data} is the name of the container DcmDspPidData.</p>		





Multiplicity	1		
Type	EcucEnumerationParamDef		
Range	USE_DATA_SENDER_RECEIVER	-	
	USE_DATA_SENDER_RECEIVER_AS_SERVICE	-	
	USE_DATA_SYNCH_CLIENT_SERVER	-	
	USE_DATA_SYNCH_FNC	-	
Post-Build Variant Value	false		
Value Configuration Class	Pre-compile time	X	All Variants
	Link time	-	
	Post-build time	-	
Scope / Dependency	scope: ECU		

Included Containers		
Container Name	Multiplicity	Scope / Dependency
DcmDspDiagnosisScaling	0..1	This container contains the configuration (parameters) of an alternative Diagnosis Representation. Out if this the scaling between Diagnosis and ECU internal representation and vice versa can be calculated.
DcmDspPidService01ExternalSRDataElementClass	0..1	This container defines the source of data in a provided port which shall be read respectively the target of data in a required port which shall be written. This container shall contain either one DcmSubElementInDataElementInstance OR DcmDataElementInstance OR DcmSubElementInImplDataElementInstance reference.

C.5.6 DcmDspDidRead

SWS Item	[ECUC_Dcm_00613]
Container Name	DcmDspDidRead
Parent Container	DcmDspDidInfo
Description	This container contains the configuration (parameters) of the DID read.
Configuration Parameters	

SWS Item	[ECUC_Dcm_00917]
Parameter Name	DcmDspDidReadModeRuleRef
Parent Container	DcmDspDidRead
Description	Reference to DcmModeRule Mode rule which controls to read this DID. If there is no reference, no check of the mode rule shall be done.
Multiplicity	0..1
Type	Reference to DcmModeRule
Post-Build Variant Multiplicity	false
Post-Build Variant Value	false





Multiplicity Configuration Class	Pre-compile time	X	VARIANT-PRE-COMPILE, VARIANT-POST-BUILD
	Link time	X	VARIANT-LINK-TIME
	Post-build time	–	
Value Configuration Class	Pre-compile time	X	VARIANT-PRE-COMPILE, VARIANT-POST-BUILD
	Link time	X	VARIANT-LINK-TIME
	Post-build time	–	
Scope / Dependency	scope: ECU		

SWS Item	[ECUC_Dcm_01141]		
Parameter Name	DcmDspDidReadRoleRef		
Parent Container	DcmDspDidRead		
Description	Reference to DcmDspAuthenticationRow that defines a role in that this DID can be read.		
Multiplicity	0..32		
Type	Reference to DcmDspAuthenticationRow		
Post-Build Variant Multiplicity	false		
Post-Build Variant Value	false		
Value Configuration Class	Pre-compile time	X	All Variants
	Link time	–	
	Post-build time	–	
Scope / Dependency	scope: ECU		

SWS Item	[ECUC_Dcm_00614]		
Parameter Name	DcmDspDidReadSecurityLevelRef		
Parent Container	DcmDspDidRead		
Description	Reference to DcmDspSecurityRow Referenced security levels are allowed to read this DID. If there is no reference, no check of security level shall be done.		
Multiplicity	0..*		
Type	Reference to DcmDspSecurityRow		
Post-Build Variant Multiplicity	false		
Post-Build Variant Value	false		
Multiplicity Configuration Class	Pre-compile time	X	VARIANT-PRE-COMPILE, VARIANT-POST-BUILD
	Link time	X	VARIANT-LINK-TIME
	Post-build time	–	
Value Configuration Class	Pre-compile time	X	VARIANT-PRE-COMPILE, VARIANT-POST-BUILD
	Link time	X	VARIANT-LINK-TIME
	Post-build time	–	
Scope / Dependency	scope: ECU		

SWS Item	[ECUC_Dcm_00615]		
Parameter Name	DcmDspDidReadSessionRef		
Parent Container	DcmDspDidRead		





Description	Reference to DcmDspSessionRow Referenced sessions are allowed to read this DID. If there is no reference, no check of session level shall be done.		
Multiplicity	0..*		
Type	Reference to DcmDspSessionRow		
Post-Build Variant Multiplicity	false		
Post-Build Variant Value	false		
Multiplicity Configuration Class	Pre-compile time	X	VARIANT-PRE-COMPILE, VARIANT-POST-BUILD
	Link time	X	VARIANT-LINK-TIME
	Post-build time	–	
Value Configuration Class	Pre-compile time	X	VARIANT-PRE-COMPILE, VARIANT-POST-BUILD
	Link time	X	VARIANT-LINK-TIME
	Post-build time	–	
Scope / Dependency	scope: ECU		

No Included Containers

C.5.7 DcmDspDidWrite

SWS Item	[ECUC_Dcm_00616]
Container Name	DcmDspDidWrite
Parent Container	DcmDspDidInfo
Description	This container contains the configuration (parameters) of the DID write.
Configuration Parameters	

SWS Item	[ECUC_Dcm_00922]		
Parameter Name	DcmDspDidWriteModeRuleRef		
Parent Container	DcmDspDidWrite		
Description	Reference to DcmModeRule Mode rule which controls to write this DID. If there is no reference, no check of the mode rule shall be done.		
Multiplicity	0..1		
Type	Reference to DcmModeRule		
Post-Build Variant Multiplicity	false		
Post-Build Variant Value	false		
Multiplicity Configuration Class	Pre-compile time	X	VARIANT-PRE-COMPILE, VARIANT-POST-BUILD
	Link time	X	VARIANT-LINK-TIME
	Post-build time	–	
Value Configuration Class	Pre-compile time	X	VARIANT-PRE-COMPILE, VARIANT-POST-BUILD
	Link time	X	VARIANT-LINK-TIME
	Post-build time	–	
Scope / Dependency	scope: ECU		

SWS Item	[ECUC_Dcm_01142]		
Parameter Name	DcmDspDidWriteRoleRef		
Parent Container	DcmDspDidWrite		
Description	Reference to DcmDspAuthenticationRow that defines a role in that this DID can be written.		
Multiplicity	0..32		
Type	Reference to DcmDspAuthenticationRow		
Post-Build Variant Multiplicity	false		
Post-Build Variant Value	false		
Value Configuration Class	Pre-compile time	X	All Variants
	Link time	–	
	Post-build time	–	
Scope / Dependency	scope: ECU		

SWS Item	[ECUC_Dcm_00617]		
Parameter Name	DcmDspDidWriteSecurityLevelRef		
Parent Container	DcmDspDidWrite		
Description	Reference to DcmDspSecurityRow Referenced security levels are allowed to wirte this DID. If there is no reference, no check of security level shall be done.		
Multiplicity	0..*		
Type	Reference to DcmDspSecurityRow		
Post-Build Variant Multiplicity	false		
Post-Build Variant Value	false		
Multiplicity Configuration Class	Pre-compile time	X	VARIANT-PRE-COMPILE, VARIANT-POST-BUILD
	Link time	X	VARIANT-LINK-TIME
	Post-build time	–	
Value Configuration Class	Pre-compile time	X	VARIANT-PRE-COMPILE, VARIANT-POST-BUILD
	Link time	X	VARIANT-LINK-TIME
	Post-build time	–	
Scope / Dependency	scope: ECU		

SWS Item	[ECUC_Dcm_00618]		
Parameter Name	DcmDspDidWriteSessionRef		
Parent Container	DcmDspDidWrite		
Description	Reference to DcmDspSessionRow Referenced sessions are allowed to write this DID. If there is no reference, no check of session level shall be done.		
Multiplicity	0..*		
Type	Reference to DcmDspSessionRow		
Post-Build Variant Multiplicity	false		
Post-Build Variant Value	false		
Multiplicity Configuration Class	Pre-compile time	X	VARIANT-PRE-COMPILE, VARIANT-POST-BUILD
	Link time	X	VARIANT-LINK-TIME
	Post-build time	–	
Value Configuration Class	Pre-compile time	X	VARIANT-PRE-COMPILE, VARIANT-POST-BUILD





	Link time	X	VARIANT-LINK-TIME
	Post-build time	–	
Scope / Dependency	scope: ECU		

No Included Containers

C.5.8 DcmDspDidControl

SWS Item	[ECUC_Dcm_00619]		
Container Name	DcmDspDidControl		
Parent Container	DcmDspDidInfo		
Description	This container contains the configuration (parameters) of the DID control.		
Configuration Parameters			

SWS Item	[ECUC_Dcm_01059]		
Parameter Name	DcmDspDidControlMask		
Parent Container	DcmDspDidControl		
Description	This indicates the presence of "controlEnableMask" in SWC service interfaces and defines how the Dcm treats a service request.		
Multiplicity	1		
Type	EcucEnumerationParamDef		
Range	DCM_CONTROLMASK_EXTERNAL	The control enable mask record shall be forwarded within each interface and is handled externally.	
	DCM_CONTROLMASK_INTERNAL	The control enable mask record is handled internally and Dcm controls only the included signals.	
	DCM_CONTROLMASK_NO	No control enable mask handling.	
Default value	DCM_CONTROLMASK_INTERNAL		
Post-Build Variant Value	false		
Value Configuration Class	Pre-compile time	X	All Variants
	Link time	–	
	Post-build time	–	
Scope / Dependency	scope: ECU		

SWS Item	[ECUC_Dcm_01060]		
Parameter Name	DcmDspDidControlMaskSize		
Parent Container	DcmDspDidControl		
Description	The value defines the size of the controlEnableMaskRecord in bytes.		
Multiplicity	0..1		
Type	EcucIntegerParamDef		
Range	1 .. 4294967294		
Default value	–		
Post-Build Variant Value	false		
Value Configuration Class	Pre-compile time	X	All Variants
	Link time	–	
	Post-build time	–	





	Link time	–	
	Post-build time	–	
Scope / Dependency	scope: ECU		

SWS Item	[ECUC_Dcm_00624]		
Parameter Name	DcmDspDidFreezeCurrentState		
Parent Container	DcmDspDidControl		
Description	This indicates the presence of "FreezeCurrentState".		
Multiplicity	1		
Type	EcucBooleanParamDef		
Default value	–		
Post-Build Variant Value	false		
Value Configuration Class	Pre-compile time	X	All Variants
	Link time	–	
	Post-build time	–	
Scope / Dependency	scope: ECU		

SWS Item	[ECUC_Dcm_00623]		
Parameter Name	DcmDspDidResetToDefault		
Parent Container	DcmDspDidControl		
Description	This indicates the presence of "ResetToDefault".		
Multiplicity	1		
Type	EcucBooleanParamDef		
Default value	–		
Post-Build Variant Value	false		
Value Configuration Class	Pre-compile time	X	All Variants
	Link time	–	
	Post-build time	–	
Scope / Dependency	scope: ECU		

SWS Item	[ECUC_Dcm_00625]		
Parameter Name	DcmDspDidShortTermAdjustment		
Parent Container	DcmDspDidControl		
Description	This indicates the presence of "ShortTermAdjustment".		
Multiplicity	1		
Type	EcucBooleanParamDef		
Default value	–		
Post-Build Variant Value	false		
Value Configuration Class	Pre-compile time	X	All Variants
	Link time	–	
	Post-build time	–	
Scope / Dependency	scope: ECU		

SWS Item	[ECUC_Dcm_00923]		
Parameter Name	DcmDspDidControlModeRuleRef		
Parent Container	DcmDspDidControl		





Description	Reference to DcmModeRule Mode rule which controls this DID. If there is no reference, no check of the mode rule shall be done.		
Multiplicity	0..1		
Type	Reference to DcmModeRule		
Post-Build Variant Multiplicity	false		
Post-Build Variant Value	false		
Multiplicity Configuration Class	Pre-compile time	X	VARIANT-PRE-COMPILE, VARIANT-POST-BUILD
	Link time	X	VARIANT-LINK-TIME
	Post-build time	–	
Value Configuration Class	Pre-compile time	X	VARIANT-PRE-COMPILE, VARIANT-POST-BUILD
	Link time	X	VARIANT-LINK-TIME
	Post-build time	–	
Scope / Dependency	scope: ECU		

SWS Item	[ECUC_Dcm_01143]		
Parameter Name	DcmDspDidControlRoleRef		
Parent Container	DcmDspDidControl		
Description	Reference to DcmDspAuthenticationRow that defines a role in that this IO can be controlled.		
Multiplicity	0..32		
Type	Reference to DcmDspAuthenticationRow		
Post-Build Variant Multiplicity	false		
Post-Build Variant Value	false		
Value Configuration Class	Pre-compile time	X	All Variants
	Link time	–	
	Post-build time	–	
Scope / Dependency	scope: ECU		

SWS Item	[ECUC_Dcm_00620]		
Parameter Name	DcmDspDidControlSecurityLevelRef		
Parent Container	DcmDspDidControl		
Description	Reference to DcmDspSecurityRow Security levels allowed to control this DID. If there is no reference, no check of security level shall be done.		
Multiplicity	0..*		
Type	Reference to DcmDspSecurityRow		
Post-Build Variant Multiplicity	false		
Post-Build Variant Value	false		
Multiplicity Configuration Class	Pre-compile time	X	VARIANT-PRE-COMPILE, VARIANT-POST-BUILD
	Link time	X	VARIANT-LINK-TIME
	Post-build time	–	
Value Configuration Class	Pre-compile time	X	VARIANT-PRE-COMPILE, VARIANT-POST-BUILD
	Link time	X	VARIANT-LINK-TIME
	Post-build time	–	
Scope / Dependency	scope: ECU		

SWS Item	[ECUC_Dcm_00621]		
Parameter Name	DcmDspDidControlSessionRef		
Parent Container	DcmDspDidControl		
Description	Reference to DcmDspSessionRow Sessions allowed to control this DID. If there is no reference, no check of session level shall be done.		
Multiplicity	0..*		
Type	Reference to DcmDspSessionRow		
Post-Build Variant Multiplicity	false		
Post-Build Variant Value	false		
Multiplicity Configuration Class	Pre-compile time	X	VARIANT-PRE-COMPILE, VARIANT-POST-BUILD
	Link time	X	VARIANT-LINK-TIME
	Post-build time	–	
Value Configuration Class	Pre-compile time	X	VARIANT-PRE-COMPILE, VARIANT-POST-BUILD
	Link time	X	VARIANT-LINK-TIME
	Post-build time	–	
Scope / Dependency	scope: ECU		

Included Containers		
Container Name	Multiplicity	Scope / Dependency
DcmDspDidControlEnableMask	0..32	The shortname of the container value defines the symbol of the controlMask.

C.5.9 DcmDspRoutine

SWS Item	[ECUC_Dcm_00640]
Container Name	DcmDspRoutine
Parent Container	DcmDsp
Description	This container contains the configuration (parameters) for Routines
Configuration Parameters	

SWS Item	[ECUC_Dcm_01215]
Parameter Name	DcmDspRoutineFncSignature
Parent Container	DcmDspRoutine
Description	<p>If the parameter is set to ROUTINE_FNC_NORMAL the routine control functions DcmDspStartRoutineFnc, DcmDspStopRoutineFnc or DcmDspRequestResultsRoutineFnc are defined with the signature for a cluster local user with separate arguments per signal. If the parameter is set to ROUTINE_FNC_PROXY the routine control functions DcmDspStartRoutineFnc, DcmDspStopRoutineFnc or DcmDspRequestResultsRoutineFnc with a fixed number of arguments passing a common buffer for all signals and a DataLength.</p> <p>Tags: atp.Status=draft</p>
Multiplicity	1
Type	EcucEnumerationParamDef





Range	ROUTINE_FNC_NORMAL	Function calls with normal set of arguments used for Sw Cluster internal interfaces. Tags: atp.Status=draft	
	ROUTINE_FNC_PROXY	Function call used with generic set of arguments used for Dcm low proxy. Tags: atp.Status=draft	
Default value	ROUTINE_FNC_NORMAL		
Post-Build Variant Value	false		
Value Configuration Class	Pre-compile time	X	All Variants
	Link time	–	
	Post-build time	–	
Scope / Dependency	scope: ECU		

SWS Item	[ECUC_Dcm_00641]		
Parameter Name	DcmDspRoutineIdentifier		
Parent Container	DcmDspRoutine		
Description	2 bytes Identifier of the RID Within each DcmConfigSet all DcmDspRoutineIdentifier values shall be unique.		
Multiplicity	1		
Type	EcucIntegerParamDef		
Range	0 .. 65535		
Default value	–		
Post-Build Variant Value	false		
Value Configuration Class	Pre-compile time	X	VARIANT-PRE-COMPILE, VARIANT-POST-BUILD
	Link time	X	VARIANT-LINK-TIME
	Post-build time	–	
Scope / Dependency	scope: ECU		

SWS Item	[ECUC_Dcm_01063]		
Parameter Name	DcmDspRoutineInfoByte		
Parent Container	DcmDspRoutine		
Description	Manufacturer specific value reported to the tester for the record identifiers 0xE000 to 0xE1FF. (OBD use cases)		
Multiplicity	0..1		
Type	EcucIntegerParamDef		
Range	0 .. 255		
Default value	–		
Post-Build Variant Value	false		
Value Configuration Class	Pre-compile time	X	VARIANT-PRE-COMPILE, VARIANT-POST-BUILD
	Link time	X	VARIANT-LINK-TIME
	Post-build time	–	
Scope / Dependency	scope: ECU		

SWS Item	[ECUC_Dcm_00807]		
Parameter Name	DcmDspRoutineUsed		
Parent Container	DcmDspRoutine		
Description	Allow to activate or deactivate the usage of a Routine, for multi purpose ECUs True = Routine is available False = Routine is not available		
Multiplicity	1		
Type	EcucBooleanParamDef		
Default value	-		
Post-Build Variant Value	true		
Value Configuration Class	Pre-compile time	X	VARIANT-PRE-COMPILE
	Link time	X	VARIANT-LINK-TIME
	Post-build time	X	VARIANT-POST-BUILD
Scope / Dependency	scope: ECU		

SWS Item	[ECUC_Dcm_00724]		
Parameter Name	DcmDspRoutineUsePort		
Parent Container	DcmDspRoutine		
Description	<p>If this parameter is set to true, the DCM uses a port requiring a PortInterface Routine Services_{RoutineName}.</p> <p>The R-Port is named RoutineServices_{RoutineName} where {RoutineName} is the name of the container DcmDspRoutine In that case, the configuration must not provide function names in DcmDspStartRoutineFnc, DcmDspStopRoutineFnc or DcmDsp RequestResultsRoutineFnc. If this is false, the DCM expects to find the names of the functions to be used in DcmDspStartRoutineFnc, DcmDspStopRoutineFnc or DcmDsp RequestResultsRoutineFnc.</p>		
Multiplicity	1		
Type	EcucBooleanParamDef		
Default value	-		
Post-Build Variant Multiplicity	false		
Post-Build Variant Value	false		
Multiplicity Configuration Class	Pre-compile time	X	All Variants
	Link time	-	
	Post-build time	-	
Value Configuration Class	Pre-compile time	X	All Variants
	Link time	-	
	Post-build time	-	
Scope / Dependency	scope: ECU		

Included Containers		
Container Name	Multiplicity	Scope / Dependency
DcmDspRequestRoutineResults	0..1	Provides the configuration of RequestResult subservice for RoutineControl service. Existence indicates that the Request RoutineResults in the RoutineControl is supported.
DcmDspStartRoutine	0..1	Provides the configuration of Start subservice for RoutineControl service.
DcmDspStopRoutine	0..1	Provides the configuration of Stop subservice for RoutineControl service. Existence indicates that the StopRoutine in the Routine Control is supported.

C.6 Dem

C.6.1 DemEventParameter

SWS Item	[ECUC_Dem_00661]
Container Name	DemEventParameter
Parent Container	DemConfigSet
Description	This container contains the configuration (parameters) for events.
Configuration Parameters	

SWS Item	[ECUC_Dem_00921]		
Parameter Name	DemCausalityDelayTime		
Parent Container	DemEventParameter		
Description	Time to wait until the event is considered as causal. The parameter is specified in seconds.		
Multiplicity	0..1		
Type	EcucFloatParamDef		
Range	[0 .. 2.5]		
Default value	0		
Post-Build Variant Multiplicity	false		
Post-Build Variant Value	false		
Multiplicity Configuration Class	Pre-compile time	X	All Variants
	Link time	–	
	Post-build time	–	
Value Configuration Class	Pre-compile time	X	All Variants
	Link time	–	
	Post-build time	–	
Scope / Dependency	scope: local		

SWS Item	[ECUC_Dem_00909]		
Parameter Name	DemComponentPriority		
Parent Container	DemEventParameter		
Description	Specifies the priority within the component. A lower value means higher priority.		
Multiplicity	0..1		
Type	EcucIntegerParamDef		
Range	0 .. 255		
Default value	–		
Post-Build Variant Multiplicity	false		
Post-Build Variant Value	false		
Multiplicity Configuration Class	Pre-compile time	X	All Variants
	Link time	–	
	Post-build time	–	
Value Configuration Class	Pre-compile time	X	All Variants
	Link time	–	
	Post-build time	–	
Scope / Dependency	scope: local		

SWS Item	[ECUC_Dem_00969]		
Parameter Name	DemEventAssociatedIdentification		
Parent Container	DemEventParameter		
Description	Event associated identifier that allows to identify an event. This value can be reported as internal data element in snapshot records or extended data records.		
Multiplicity	0..1		
Type	EcucIntegerParamDef		
Range	0 .. 65535		
Default value	–		
Post-Build Variant Value	true		
Value Configuration Class	Pre-compile time	X	VARIANT-PRE-COMPILE
	Link time	–	
	Post-build time	X	VARIANT-POST-BUILD
Scope / Dependency	scope: ECU		

SWS Item	[ECUC_Dem_00792]		
Parameter Name	DemEventAvailable		
Parent Container	DemEventParameter		
Description	This parameter configures an Event as unavailable. It is treated by Dem as if it does not exist. true = Event is available false = Event is not available		
Multiplicity	1		
Type	EcucBooleanParamDef		
Default value	–		
Post-Build Variant Value	true		
Value Configuration Class	Pre-compile time	X	VARIANT-PRE-COMPILE
	Link time	–	
	Post-build time	X	VARIANT-POST-BUILD
Scope / Dependency	scope: ECU		

SWS Item	[ECUC_Dem_00968]		
Parameter Name	DemEventAvailableInVariant		
Parent Container	DemEventParameter		
Description	This parameter defines the enabled or disabled status of an event. If set to FALSE, the Event is generally disabled, even though the SW-C is integrated and the Event is described in the ECUC. The Dem shall ignore all calls from the SW-C. If set to TRUE, the availability of the event depends on other availability sources.		
Multiplicity	0..1		
Type	EcucBooleanParamDef		
Default value	true		
Post-Build Variant Multiplicity	false		
Post-Build Variant Value	true		
Multiplicity Configuration Class	Pre-compile time	X	All Variants
	Link time	–	
	Post-build time	–	
Value Configuration Class	Pre-compile time	X	VARIANT-PRE-COMPILE
	Link time	–	
	Post-build time	X	VARIANT-POST-BUILD
Scope / Dependency	scope: ECU		

SWS Item	[ECUC_Dem_00924]		
Parameter Name	DemEventConfirmationThreshold		
Parent Container	DemEventParameter		
Description	Defines the operation cycle threshold of the DTC confirmation status according "Confirmation Threshold" of ISO 14229-1.		
Multiplicity	1		
Type	EcucIntegerParamDef		
Range	1 .. 255		
Default value	1		
Post-Build Variant Value	true		
Value Configuration Class	Pre-compile time	X	VARIANT-PRE-COMPILE
	Link time	–	
	Post-build time	X	VARIANT-POST-BUILD
Scope / Dependency	scope: ECU		

SWS Item	[ECUC_Dem_00929]		
Parameter Name	DemEventConfirmationThresholdCounterAdaptable		
Parent Container	DemEventParameter		
Description	Indicates whether the events confirmation Cycle threshold can be adapted by Dem_Set EventConfirmationThresholdCounter.		
Multiplicity	0..1		
Type	EcucBooleanParamDef		
Default value	false		
Post-Build Variant Value	false		
Value Configuration Class	Pre-compile time	X	All Variants
	Link time	–	
	Post-build time	–	
Scope / Dependency	scope: ECU		

SWS Item	[ECUC_Dem_00659]		
Parameter Name	DemEventId		
Parent Container	DemEventParameter		
Description	<p>Unique identifier of a diagnostic event.</p> <p>This parameter should not be changeable by user, because the Id should be generated by Dem itself to prevent gaps and multiple use of an Id. The events should be sequentially ordered beginning with 1 and no gaps in between.</p>		
Multiplicity	1		
Type	EcucIntegerParamDef (Symbolic Name generated for this parameter)		
Range	1 .. 65535		
Default value	–		
Post-Build Variant Value	false		
Value Configuration Class	Pre-compile time	X	All Variants
	Link time	–	
	Post-build time	–	
Scope / Dependency	scope: ECU		

SWS Item	[ECUC_Dem_00660]		
Parameter Name	DemEventKind		
Parent Container	DemEventParameter		
Description	This parameter is used to distinguish between SW-C and BSW events.		
Multiplicity	1		
Type	EcucEnumerationParamDef		
Range	DEM_EVENT_KIND_BSW	The event is assigned to a BSW module	
	DEM_EVENT_KIND_SWC	The event is assigned to a SW-C	
Default value	DEM_EVENT_KIND_SWC		
Post-Build Variant Value	false		
Value Configuration Class	Pre-compile time	X	All Variants
	Link time	–	
	Post-build time	–	
Scope / Dependency			

SWS Item	[ECUC_Dem_00916]		
Parameter Name	DemEventRecoverableInSameOperationCycle		
Parent Container	DemEventParameter		
Description	If parameter is configured to FALSE, reporting of PASSED will be ignored if the event is already "testfailed this operation cycle".		
Multiplicity	0..1		
Type	EcucBooleanParamDef		
Default value	true		
Post-Build Variant Value	true		
Value Configuration Class	Pre-compile time	X	All Variants
	Link time	–	
	Post-build time	–	
Scope / Dependency	scope: ECU		

SWS Item	[ECUC_Dem_00970]		
Parameter Name	DemEventReportingType		
Parent Container	DemEventParameter		
Description	This parameter defines the way a monitor can report an event to the Dem. There are various ways to report an event and the Dem provides different APIs for it. Tags: atp.Status=draft		
Multiplicity	1		
Type	EcucEnumerationParamDef		
Range	IMMEDIATE_FAIL_AND_SYNCHRONOUS_PROCESSING	The event is reported over the API Dem_SetEventFailedWithSyncFreezeFrame. Tags: atp.Status=draft	
	STANDARD_REPORTING	The event is reported over the API Dem_SetEventStatus. Tags: atp.Status=draft	
	STANDARD_REPORTING_WITH_MONITOR_DATA	The event is reported over the API Dem_SetEventStatusWithMonitorData. Tags: atp.Status=draft	
Default value	STANDARD_REPORTING		
Post-Build Variant Value	false		





Value Configuration Class	Pre-compile time	X	All Variants
	Link time	–	
	Post-build time	–	
Scope / Dependency	scope: local		

SWS Item	[ECUC_Dem_00948]		
Parameter Name	DemFFPrestorageInNvm		
Parent Container	DemEventParameter		
Description	If the event uses a pre-stored freeze-frame this attribute indicates if the event requires the pre-stored data to be stored in non-volatile memory. TRUE = store the pre-stored data in non-volatile memory, FALSE = pre-stored data is not stored in non-volatile memory.		
Multiplicity	0..1		
Type	EcucBooleanParamDef		
Default value	–		
Post-Build Variant Value	false		
Value Configuration Class	Pre-compile time	X	All Variants
	Link time	–	
	Post-build time	–	
Scope / Dependency	scope: local		

SWS Item	[ECUC_Dem_00671]		
Parameter Name	DemFFPrestorageSupported		
Parent Container	DemEventParameter		
Description	If this parameter is set to true, then the Prestorage of FreezeFrames is supported by the assigned event. This parameter is useful to calculate the buffer size.		
Multiplicity	1		
Type	EcucBooleanParamDef		
Default value	false		
Post-Build Variant Value	false		
Value Configuration Class	Pre-compile time	X	All Variants
	Link time	–	
	Post-build time	–	
Scope / Dependency	scope: ECU		

SWS Item	[ECUC_Dem_00894]		
Parameter Name	DemReportBehavior		
Parent Container	DemEventParameter		
Description	Indicates the reporting behavior of the BSW Module (DemEventKind == DEM_EVENT_KIND_BSW) in order to determine the size of the reporting queue. If the parameter is not defined it means REPORT_BEFORE_INIT.		
Multiplicity	0..1		
Type	EcucEnumerationParamDef		
Range	REPORT_AFTER_INIT	Indicates that the Event will not be reported before Dem_Init().	
	REPORT_BEFORE_INIT	Indicates that the Event may be reported before Dem_Init().	
Default value	REPORT_BEFORE_INIT		





Post-Build Variant Multiplicity	false		
Post-Build Variant Value	false		
Multiplicity Configuration Class	Pre-compile time	X	All Variants
	Link time	–	
	Post-build time	–	
Value Configuration Class	Pre-compile time	X	All Variants
	Link time	–	
	Post-build time	–	
Scope / Dependency	scope: local		

SWS Item	[ECUC_Dem_00908]		
Parameter Name	DemComponentClassRef		
Parent Container	DemEventParameter		
Description	Reference to the monitored component.		
Multiplicity	0..1		
Type	Reference to DemComponent		
Post-Build Variant Multiplicity	false		
Post-Build Variant Value	false		
Multiplicity Configuration Class	Pre-compile time	X	All Variants
	Link time	–	
	Post-build time	–	
Value Configuration Class	Pre-compile time	X	All Variants
	Link time	–	
	Post-build time	–	
Scope / Dependency	scope: local		

SWS Item	[ECUC_Dem_00888]		
Parameter Name	DemDTCRef		
Parent Container	DemEventParameter		
Description	<p>This parameter defines the DTC configuration (typically Uds) associated with the diagnostic event.</p> <p>It is allowed to have events without a DTC (e.g. for ECU-internal events triggering safety reactions without being reported via diagnostic communication). The same DemDTCAttributes can be used from several events, to combine these (refer to chapter "Combination of diagnostic event").</p>		
Multiplicity	0..1		
Type	Reference to DemDTC		
Post-Build Variant Multiplicity	false		
Post-Build Variant Value	false		
Multiplicity Configuration Class	Pre-compile time	X	All Variants
	Link time	–	
	Post-build time	–	
Value Configuration Class	Pre-compile time	X	All Variants
	Link time	–	
	Post-build time	–	
Scope / Dependency			

SWS Item	[ECUC_Dem_00746]		
Parameter Name	DemEnableConditionGroupRef		
Parent Container	DemEventParameter		
Description	References an enable condition group.		
Multiplicity	0..1		
Type	Reference to DemEnableConditionGroup		
Post-Build Variant Multiplicity	false		
Post-Build Variant Value	false		
Multiplicity Configuration Class	Pre-compile time	X	All Variants
	Link time	–	
	Post-build time	–	
Value Configuration Class	Pre-compile time	X	All Variants
	Link time	–	
	Post-build time	–	
Scope / Dependency	scope: ECU		

SWS Item	[ECUC_Dem_00839]		
Parameter Name	DemOBDDGroupingAssociativeEventsRef		
Parent Container	DemEventParameter		
Description	This parameter defines a reference which points to a representative event of one group of associate events. The "reverence event" must refer to it self. Note: One event is only allowed to be reverenced to only one group of associate events.		
Multiplicity	0..1		
Type	Reference to DemEventParameter		
Post-Build Variant Multiplicity	false		
Post-Build Variant Value	false		
Multiplicity Configuration Class	Pre-compile time	X	All Variants
	Link time	–	
	Post-build time	–	
Value Configuration Class	Pre-compile time	X	All Variants
	Link time	–	
	Post-build time	–	
Scope / Dependency	scope: ECU		

SWS Item	[ECUC_Dem_00702]		
Parameter Name	DemOperationCycleRef		
Parent Container	DemEventParameter		
Description	Kind of operation cycle for the event (e.g. power cycle, driving cycle, ...)		
Multiplicity	1		
Type	Reference to DemOperationCycle		
Post-Build Variant Value	false		
Value Configuration Class	Pre-compile time	X	All Variants
	Link time	–	
	Post-build time	–	
Scope / Dependency	scope: ECU		

SWS Item	[ECUC_Dem_00769]		
Parameter Name	DemStorageConditionGroupRef		
Parent Container	DemEventParameter		
Description	References a storage condition group.		
Multiplicity	0..1		
Type	Reference to DemStorageConditionGroup		
Post-Build Variant Multiplicity	false		
Post-Build Variant Value	false		
Multiplicity Configuration Class	Pre-compile time	X	All Variants
	Link time	–	
	Post-build time	–	
Value Configuration Class	Pre-compile time	X	All Variants
	Link time	–	
	Post-build time	–	
Scope / Dependency	scope: ECU		

Included Containers		
Container Name	Multiplicity	Scope / Dependency
DemCallbackClearEventAllowed	0..1	<p>The presence of this container indicates that the Dem has access to a "ClearEventAllowed" callback.</p> <p>In case there is a DemCallbackClearEventAllowedFnc, this parameter defines the name of the function that the Dem will call.</p> <p>In case there is no DemCallbackClearEventAllowedFnc, the Dem will have an R-Port requiring the interface CallbackClearEventAllowed whose name is generated by using the unique callback-prefix followed by the event name.</p>
DemCallbackEventDataChanged	0..1	<p>The presence of this container indicates that the Dem has access to an "EventDataChanged" callback.</p> <p>In case there is a DemCallbackEventDataChangedFnc, this parameter defines the name of the function that the Dem will call.</p> <p>In case there is no DemCallbackEventDataChangedFnc, the Dem will have an R-Port requiring the interface CallbackEventDataChanged whose name is generated by using the unique callback-prefix followed by the event name.</p>
DemCallbackEventSyncStorageProcessed	0..1	<p>The presence of this container indicates that the Dem will call the configured callback after an event status reported with Dem_SetEventFailedWithSyncFreezeFrame is finished and the Dem is ready to process a next call for this event.</p> <p>Tags: atp.Status=draft</p>
DemCallbackEventUdsStatusChanged	0..*	<p>The presence of this container indicates, that the Dem has access to an "EventUdsStatusChanged" callback, which the Dem will call to notify other components about the change in the status of an event.</p> <p>In case there is a DemCallbackEventUdsStatusChangedFnc, this parameter defines the name of the function that the Dem will call.</p> <p>In case there is no DemCallbackEventUdsStatusChangedFnc, the Dem will have an R-Port requiring the interface CallbackEventUdsStatusChanged, whose name is generated by using the unique callback-prefix followed by the event name.</p>





Included Containers		
Container Name	Multiplicity	Scope / Dependency
DemCallbackInitMForE	0..1	<p>The presence of this container indicates, that the Dem has access to an "InitMonitorForEvent" callback, which the Dem will call to initialize a monitor.</p> <p>In case the container has a DemCallbackInitMForEFnc, this parameter defines the name of the function that the Dem will call.</p> <p>In case there is no DemCallbackInitMForEFnc, the Dem will have an R-Port requiring the interface CallbackInitMonitorForEvent, whose name is generated by using the unique callback-prefix followed by the event name.</p>
DemCallbackMonitorStatus Changed	0..*	<p>The presence of this container indicates, that the Dem has access to an "MonitorStatusChanged" callback, which the Dem will call to notify other components about the change in the status of an event.</p> <p>In case there is a DemCallbackMonitorStatusChangedFnc, this parameter defines the name of the function that the Dem will call.</p> <p>In case there is no DemCallbackMonitorStatusChangedFnc, the Dem will have an R-Port requiring the interface CallbackMonitorStatusChanged, whose name is generated by using the unique callback-prefix followed by the event name.</p>
DemDebounceAlgorithmClass	1	Debounce algorithm class: counter based, time based, or monitor internal.
DemIndicatorAttribute	0..255	This container contains the event specific configuration of Indicators.

C.6.2 DemDataElementClass

SWS Item	[ECUC_Dem_00610]
Choice Container Name	DemDataElementClass
Parent Container	DemGeneral
Description	This container contains the configuration (parameters) for an internal/external data element class.

Container Choices		
Container Name	Multiplicity	Scope / Dependency
DemExternalCSDataElementClass	0..1	<p>This container contains the configuration (parameters) for an external client/server based data element class.</p> <p>It defines, how the Dem can obtain the value of the data element from either a SW-C or another BSW module. Whether a client/server port or a C function-call is used, is defined by DemDataElementUsePort.</p>
DemExternalSRDataElementClass	0..1	This container contains the configuration (parameters) for an external sender/receiver based data element class. It defines, how the Dem can obtain the value of the data element from a SW-C, by using a sender/receiver port.
DemInternalDataElementClass	0..1	This container contains the configuration (parameters) for an internal data element class.

C.7 FiM

C.7.1 FiMFID

SWS Item	[ECUC_FiM_00039]
Container Name	FiMFID
Parent Container	FiMConfigSet
Description	This container includes symbolic names of all FIDs.
Configuration Parameters	

SWS Item	[ECUC_FiM_00085]		
Parameter Name	FiMFunctionId		
Parent Container	FiMFID		
Description	<p>Unique identifier of a FimFunctionId. This parameter should not be changeable by user, because the Id should be generated by Fim itself to prevent gaps and multiple use of an Id.</p> <p>Note: The implementer can add the attribute 'withAuto' to the parameter definition which indicates that the value can be calculated by the generator automatically. When 'withAuto' is set to 'true' for this parameter definition the 'isAutoValue' can be set to 'true'. If 'isAutoValue' is set to 'true' the actual value will not be considered during ECU Configuration but will be (re-)calculated by the code generator and stored in the value attribute afterwards.</p>		
Multiplicity	1		
Type	EcucIntegerParamDef (Symbolic Name generated for this parameter)		
Range	0 .. 65535		
Default value	-		
Post-Build Variant Value	false		
Value Configuration Class	Pre-compile time	X	All Variants
	Link time	-	
	Post-build time	-	
Scope / Dependency	scope: ECU		

No Included Containers

C.8 Com

C.8.1 ComMainFunctionTx

SWS Item	[ECUC_Com_10014]		
Container Name	ComMainFunctionTx		
Parent Container	ComConfig		
Description	Each element of this container defines one instance of Com_MainFunctionTx.		
Post-Build Variant Multiplicity	false		
Multiplicity Configuration Class	Pre-compile time	X	All Variants
	Link time	-	
	Post-build time	-	





Configuration Parameters

SWS Item	[ECUC_Com_10010]		
Parameter Name	ComMainTxTimeBase		
Parent Container	ComMainFunctionTx		
Description	<p>The period between successive calls to according instance of Com_MainFunctionTx in seconds. This parameter may be used by the COM generator to transform the values of the reception related timing configuration parameters of the COM module to internal implementation specific counter or tick values. The COM module's internal timing handling is implementation specific.</p> <p>The COM module (generator) may rely on the fact that Com_MainFunctionTx is scheduled according to the value configured here.</p>		
Multiplicity	1		
Type	EcucFloatParamDef		
Range]0 .. INF[
Default value	-		
Post-Build Variant Value	false		
Value Configuration Class	Pre-compile time	X	All Variants
	Link time	-	
	Post-build time	-	
Scope / Dependency	scope: local		

SWS Item	[ECUC_Com_10020]		
Parameter Name	ComPreparationNotification		
Parent Container	ComMainFunctionTx		
Description	<p>This callback function indicates that the signals/signal groups to be sent via a dedicated Com_MainFunctionTx instance will now be prepared for transmission.</p> <p>If this parameter is omitted no notification shall take place.</p>		
Multiplicity	0..1		
Type	EcucFunctionNameDef		
Default value	-		
Regular Expression	-		
Post-Build Variant Multiplicity	false		
Post-Build Variant Value	false		
Multiplicity Configuration Class	Pre-compile time	X	All Variants
	Link time	-	
	Post-build time	-	
Value Configuration Class	Pre-compile time	X	All Variants
	Link time	-	
	Post-build time	-	
Scope / Dependency	scope: local		

SWS Item	[ECUC_Com_10019]		
Parameter Name	ComMainTxPartitionRef		
Parent Container	ComMainFunctionTx		
Description	Reference to EcucPartition, where the according Com_MainFunction instance is assigned to.		
Multiplicity	0..1		





Type	Reference to EcucPartition		
Post-Build Variant Multiplicity	false		
Post-Build Variant Value	false		
Multiplicity Configuration Class	Pre-compile time	X	All Variants
	Link time	–	
	Post-build time	–	
Value Configuration Class	Pre-compile time	X	All Variants
	Link time	–	
	Post-build time	–	
Scope / Dependency	scope: local		

No Included Containers

C.8.2 ComMainFunctionRx

SWS Item	[ECUC_Com_10011]		
Container Name	ComMainFunctionRx		
Parent Container	ComConfig		
Description	Each element of this container defines one instance of Com_MainFunctionRx.		
Post-Build Variant Multiplicity	false		
Multiplicity Configuration Class	Pre-compile time	X	All Variants
	Link time	–	
	Post-build time	–	
Configuration Parameters			

SWS Item	[ECUC_Com_10018]		
Parameter Name	ComMainRxTimeBase		
Parent Container	ComMainFunctionRx		
Description	<p>The period between successive calls to according instance of Com_MainFunctionRx in seconds. This parameter may be used by the COM generator to transform the values of the reception related timing configuration parameters of the COM module to internal implementation specific counter or tick values. The COM module's internal timing handling is implementation specific.</p> <p>The COM module (generator) may rely on the fact that Com_MainFunctionRx is scheduled according to the value configured here.</p>		
Multiplicity	1		
Type	EcucFloatParamDef		
Range]0 .. INF[
Default value	–		
Post-Build Variant Value	false		
Value Configuration Class	Pre-compile time	X	All Variants
	Link time	–	
	Post-build time	–	
Scope / Dependency	scope: local		

SWS Item	[ECUC_Com_10017]		
Parameter Name	ComMainRxPartitionRef		
Parent Container	ComMainFunctionRx		
Description	Reference to EcucPartition, where the according Com_MainFunction instance is assigned to.		
Multiplicity	0..1		
Type	Reference to EcucPartition		
Post-Build Variant Multiplicity	false		
Post-Build Variant Value	false		
Multiplicity Configuration Class	Pre-compile time	X	All Variants
	Link time	–	
	Post-build time	–	
Value Configuration Class	Pre-compile time	X	All Variants
	Link time	–	
	Post-build time	–	
Scope / Dependency	scope: local		

No Included Containers

C.8.3 ComGroupSignal

SWS Item	[ECUC_Com_00520]		
Container Name	ComGroupSignal		
Parent Container	ComSignalGroup		
Description	This container contains the configuration parameters of group signals. I.e. signals that are included within a signal group.		
Post-Build Variant Multiplicity	true		
Multiplicity Configuration Class	Pre-compile time	X	VARIANT-PRE-COMPILE
	Link time	X	VARIANT-LINK-TIME
	Post-build time	X	VARIANT-POST-BUILD
Configuration Parameters			

SWS Item	[ECUC_Com_00259]		
Parameter Name	ComBitPosition		
Parent Container	ComGroupSignal		
Description	Starting position within the I-PDU. This parameter refers to the position in the I-PDU and not in the shadow buffer. If the endianness conversion is configured to Opaque the parameter ComBitPosition shall define the bit0 of the first byte like in little endian byte order		
Multiplicity	1		
Type	EcucIntegerParamDef		
Range	0 .. 4294967295		
Default value	–		
Post-Build Variant Value	true		
Value Configuration Class	Pre-compile time	X	VARIANT-PRE-COMPILE
	Link time	X	VARIANT-LINK-TIME





	Post-build time	X	VARIANT-POST-BUILD
Scope / Dependency	scope: local		

SWS Item	[ECUC_Com_00158]		
Parameter Name	ComBitSize		
Parent Container	ComGroupSignal		
Description	Size in bits, for integer signal types. For ComSignalType UINT8_N and UINT8_DYN the size shall be configured by ComSignalLength. For ComSignalTypes FLOAT32 and FLOAT64 the size is already defined by the signal type and therefore may be omitted.		
Multiplicity	0..1		
Type	EcucIntegerParamDef		
Range	0 .. 64		
Default value	–		
Post-Build Variant Multiplicity	true		
Post-Build Variant Value	true		
Multiplicity Configuration Class	Pre-compile time	X	VARIANT-PRE-COMPILE
	Link time	X	VARIANT-LINK-TIME
	Post-build time	X	VARIANT-POST-BUILD
Value Configuration Class	Pre-compile time	X	VARIANT-PRE-COMPILE
	Link time	X	VARIANT-LINK-TIME
	Post-build time	X	VARIANT-POST-BUILD
Scope / Dependency	scope: local		

SWS Item	[ECUC_Com_00165]		
Parameter Name	ComHandleId		
Parent Container	ComGroupSignal		
Description	The numerical value used as the ID. This ID identifies signals and signal groups in the COM APIs using Com_SignalIdType or Com_SignalGroupIdType parameter respectively.		
Multiplicity	0..1		
Type	EcucIntegerParamDef (Symbolic Name generated for this parameter)		
Range	0 .. 65535		
Default value	–		
Post-Build Variant Multiplicity	false		
Post-Build Variant Value	false		
Multiplicity Configuration Class	Pre-compile time	X	All Variants
	Link time	–	
	Post-build time	–	
Value Configuration Class	Pre-compile time	X	All Variants
	Link time	–	
	Post-build time	–	
Scope / Dependency	scope: ECU		

SWS Item	[ECUC_Com_00391]		
Parameter Name	ComSignalDataInvalidValue		
Parent Container	ComGroupSignal		





Description	<p>Defines the data invalid value of the signal.</p> <p>In case the ComSignalType is UINT8, UINT16, UINT32, UINT64, SINT8, SINT16, SINT32, SINT64 the string shall be interpreted as defined in the chapter Integer Type in the AUTOSAR EcuC specification. In case the ComSignalType is FLOAT32, FLOAT64 the string shall be interpreted as defined in the chapter Float Type in the AUTOSAR EcuC specification. In case the ComSignalType is BOOLEAN the string shall be interpreted as defined in the chapter Boolean Type in the AUTOSAR EcuC specification. In case the ComSignal is a UINT8_N, UINT8_DYN the string shall be interpreted as a decimal representation of the characters separated by blanks, e.g. "97 98 100" means a string "abd", where the char "a" is in byte 0(lowest address), "b" is in byte 1, and "d" is in byte 2 and (highest address). For the ComSignalType UINT8_DYN the dynamic length shall be set to the number of configured characters. An empty string "" shall be interpreted as 0-sized dynamic signal.</p>		
Multiplicity	0..1		
Type	EcucStringParamDef		
Default value	–		
Regular Expression	–		
Post-Build Variant Multiplicity	false		
Post-Build Variant Value	false		
Multiplicity Configuration Class	Pre-compile time	X	VARIANT-PRE-COMPILE
	Link time	X	VARIANT-LINK-TIME, VARIANT-POST-BUILD
	Post-build time	–	
Value Configuration Class	Pre-compile time	X	VARIANT-PRE-COMPILE
	Link time	X	VARIANT-LINK-TIME, VARIANT-POST-BUILD
	Post-build time	–	
Scope / Dependency	<p>scope: local</p> <p>dependency: In case of UINT8_N the length of ComSignalDataInvalidValue has to be the same as ComSignalLength.</p>		

SWS Item	[ECUC_Com_00157]		
Parameter Name	ComSignalEndianness		
Parent Container	ComGroupSignal		
Description	Defines the endianness of the signal's network representation.		
Multiplicity	1		
Type	EcucEnumerationParamDef		
Range	BIG_ENDIAN	–	
	LITTLE_ENDIAN	–	
	OPAQUE	–	
Post-Build Variant Value	true		
Value Configuration Class	Pre-compile time	X	VARIANT-PRE-COMPILE
	Link time	X	VARIANT-LINK-TIME
	Post-build time	X	VARIANT-POST-BUILD
Scope / Dependency	scope: local		

SWS Item	[ECUC_Com_00170]		
Parameter Name	ComSignalInitValue		
Parent Container	ComGroupSignal		





Description	<p>Initial value for this signal. In case of UINT8_N the default value is a string of length ComSignalLength with all bytes set to 0x00. In case of UINT8_DYN the initial size shall be 0.</p> <p>In case the ComSignalType is UINT8, UINT16, UINT32, UINT64, SINT8, SINT16, SINT32, SINT64 the string shall be interpreted as defined in the chapter Integer Type in the AUTOSAR EcuC specification. In case the ComSignalType is FLOAT32, FLOAT64 the string shall be interpreted as defined in the chapter Float Type in the AUTOSAR EcuC specification. In case the ComSignalType is BOOLEAN the string shall be interpreted as defined in the chapter Boolean Type in the AUTOSAR EcuC specification. In case the ComSignal is a UINT8_N, UINT8_DYN the string shall be interpreted as a decimal representation of the characters separated by blanks, e.g. "97 98 100" means a string "abd", where the char "a" is in byte 0(lowest address), "b" is in byte 1, and "d" is in byte 2 and (highest address). For the ComSignalType UINT8_DYN the dynamic length shall be set to the number of configured characters. An empty string "" shall be interpreted as 0-sized dynamic signal.</p>		
Multiplicity	0..1		
Type	EcucStringParamDef		
Default value	0		
Regular Expression	-		
Post-Build Variant Multiplicity	true		
Post-Build Variant Value	true		
Multiplicity Configuration Class	Pre-compile time	X	VARIANT-PRE-COMPILE
	Link time	X	VARIANT-LINK-TIME
	Post-build time	X	VARIANT-POST-BUILD
Value Configuration Class	Pre-compile time	X	VARIANT-PRE-COMPILE
	Link time	X	VARIANT-LINK-TIME
	Post-build time	X	VARIANT-POST-BUILD
Scope / Dependency	<p>scope: local</p> <p>dependency: In case of UINT8_N the length of ComSignalInitValue has to be the same as ComSignalLength.</p>		

SWS Item	[ECUC_Com_00437]		
Parameter Name	ComSignalLength		
Parent Container	ComGroupSignal		
Description	<p>Description: For ComSignalType UINT8_N this parameter specifies the length n in bytes. For ComSignalType UINT8_DYN it specifies the maximum length in bytes. For all other types this parameter shall be ignored.</p> <p>The supported maximum length is restricted by the used transportation system. For non TP-PDUs the maximum size of a PDU, and therefore also of any included signal, is limited by the concrete bus characteristic. For example, the limit is 8 bytes for CAN and LIN, 64 bytes for CAN FD and 254 for FlexRay.</p>		
Multiplicity	0..1		
Type	EcucIntegerParamDef		
Range	0 .. 4294967295		
Default value	-		
Post-Build Variant Multiplicity	false		
Post-Build Variant Value	false		
Multiplicity Configuration Class	Pre-compile time	X	VARIANT-PRE-COMPILE
	Link time	X	VARIANT-LINK-TIME, VARIANT-POST-BUILD
	Post-build time	-	
Value Configuration Class	Pre-compile time	X	VARIANT-PRE-COMPILE





	Link time	X	VARIANT-LINK-TIME, VARIANT-POST-BUILD
	Post-build time	–	
Scope / Dependency	scope: local		

SWS Item	[ECUC_Com_00127]		
Parameter Name	ComSignalType		
Parent Container	ComGroupSignal		
Description	The AUTOSAR type of the signal. Whether or not the signal is signed or unsigned can be found by examining the value of this attribute. This type could also be used to reserved appropriate storage in AUTOSAR COM.		
Multiplicity	1		
Type	EcucEnumerationParamDef		
Range	BOOLEAN	–	
	FLOAT32	–	
	FLOAT64	–	
	SINT16	–	
	SINT32	–	
	SINT64	–	
	SINT8	–	
	UINT16	–	
	UINT32	–	
	UINT64	–	
	UINT8	–	
	UINT8_DYN	–	
	UINT8_N	–	
Post-Build Variant Value	false		
Value Configuration Class	Pre-compile time	X	VARIANT-PRE-COMPILE
	Link time	X	VARIANT-LINK-TIME, VARIANT-POST-BUILD
	Post-build time	–	
Scope / Dependency	scope: local		

SWS Item	[ECUC_Com_10006]		
Parameter Name	ComTimeoutSubstitutionValue		
Parent Container	ComGroupSignal		
Description	<p>The signal substitution value will be used in case of a timeout and ComRxDataTimeout Action is set to SUBSTITUTE. In case of UINT8_N the default value is a string of length ComSignalLength with all bytes set to 0x00.</p> <p>In case of UINT8_DYN the initial size shall be 0.</p> <p>In case the ComSignalType is UINT8, UINT16, UINT32, UINT64, SINT8, SINT16, SINT32, SINT64 the string shall be interpreted as defined in the chapter Integer Type in the AUTOSAR EcuC specification.</p> <p>In case the ComSignalType is FLOAT32, FLOAT64 the string shall be interpreted as defined in the chapter Float Type in the AUTOSAR EcuC specification.</p> <p>In case the ComSignalType is BOOLEAN the string shall be interpreted as defined in the chapter Boolean Type in the AUTOSAR EcuC specification.</p> <p>In case the ComSignal is a UINT8_N, UINT8_DYN the string shall be interpreted as a decimal representation of the characters separated by blanks, e.g. "97 98 100" means</p>		





	<p>△ a string "abd", where the char "a" is in byte 0(lowest address), "b" is in byte 1, and "d" is in byte 2 and (highest address). For the ComSignalType UINT8_DYN the dynamic length shall be set to the number of configured characters. An empty string "" shall be interpreted as 0-sized dynamic signal.</p>		
Multiplicity	0..1		
Type	EcucStringParamDef		
Default value	-		
Regular Expression	-		
Post-Build Variant Multiplicity	true		
Post-Build Variant Value	true		
Multiplicity Configuration Class	Pre-compile time	X	VARIANT-PRE-COMPILE
	Link time	X	VARIANT-LINK-TIME
	Post-build time	X	VARIANT-POST-BUILD
Value Configuration Class	Pre-compile time	X	VARIANT-PRE-COMPILE
	Link time	X	VARIANT-LINK-TIME
	Post-build time	X	VARIANT-POST-BUILD
Scope / Dependency	scope: local		

SWS Item	[ECUC_Com_00560]		
Parameter Name	ComTransferProperty		
Parent Container	ComGroupSignal		
Description	Optionally defines whether this group signal shall contribute to the TRIGGERED_ON_CHANGE transfer property of the signal group. If at least one group signal of a signal group has the "ComTransferProperty" configured all other group signals of that signal group shall have the attribute configured as well.		
Multiplicity	0..1		
Type	EcucEnumerationParamDef		
Range	PENDING	A change of the value of this group signal shall not be considered in the evaluation of the signal groups ComTransferProperty.	
	TRIGGERED_ON_CHANGE	A change of the value of this group signal shall be considered in the evaluation of the signal groups ComTransferProperty.	
Post-Build Variant Multiplicity	true		
Post-Build Variant Value	true		
Multiplicity Configuration Class	Pre-compile time	X	VARIANT-PRE-COMPILE
	Link time	X	VARIANT-LINK-TIME
	Post-build time	X	VARIANT-POST-BUILD
Value Configuration Class	Pre-compile time	X	VARIANT-PRE-COMPILE
	Link time	X	VARIANT-LINK-TIME
	Post-build time	X	VARIANT-POST-BUILD
Scope / Dependency	scope: local		

SWS Item	[ECUC_Com_00002]		
Parameter Name	ComSystemTemplateSystemSignalRef		
Parent Container	ComGroupSignal		
Description	Reference to the ISignalToIPduMapping that contains a reference to the ISignal (System Template) which this ComSignal (or ComGroupSignal) represents.		





Multiplicity	0..1		
Type	Foreign reference to I-SIGNAL-TO-I-PDU-MAPPING		
Post-Build Variant Multiplicity	true		
Post-Build Variant Value	true		
Multiplicity Configuration Class	Pre-compile time	X	VARIANT-PRE-COMPILE
	Link time	X	VARIANT-LINK-TIME
	Post-build time	X	VARIANT-POST-BUILD
Value Configuration Class	Pre-compile time	X	VARIANT-PRE-COMPILE
	Link time	X	VARIANT-LINK-TIME
	Post-build time	X	VARIANT-POST-BUILD
Scope / Dependency	scope: ECU		

Included Containers		
Container Name	Multiplicity	Scope / Dependency
ComFilter	0..1	This container contains the configuration parameters of the AUTOSAR COM module's filters. Note: On sender side the container is used to specify the transmission mode conditions.

C.8.4 ComIPdu

SWS Item	[ECUC_Com_00340]		
Container Name	ComIPdu		
Parent Container	ComConfig		
Description	Contains the configuration parameters of the AUTOSAR COM module's I-PDUs.		
Post-Build Variant Multiplicity	true		
Multiplicity Configuration Class	Pre-compile time	X	VARIANT-PRE-COMPILE
	Link time	X	VARIANT-LINK-TIME
	Post-build time	X	VARIANT-POST-BUILD
Configuration Parameters			

SWS Item	[ECUC_Com_00387]		
Parameter Name	ComIPduCallout		
Parent Container	ComIPdu		
Description	This parameter defines the existence and the name of a callout function for the corresponding I-PDU. If this parameter is omitted no I-PDU callout shall take place for the corresponding I-PDU.		
Multiplicity	0..1		
Type	EcucFunctionNameDef		
Default value	-		
Regular Expression	-		
Post-Build Variant Multiplicity	false		
Post-Build Variant Value	false		
Multiplicity Configuration Class	Pre-compile time	X	All Variants
	Link time	-	
	Post-build time	-	





Value Configuration Class	Pre-compile time	X	All Variants
	Link time	–	
	Post-build time	–	
Scope / Dependency	scope: local		

SWS Item	[ECUC_Com_00709]		
Parameter Name	ComIPduCancellationSupport		
Parent Container	ComIPdu		
Description	<p>Defines for I-PDUs with ComIPduType NORMAL: If the underlying IF-modul supports cancellation of transmit requests.</p> <p>Defines for I-PDUs with ComIPduType TP: If the underlying TP-module supports RX and TX cancellation of ongoing requests.</p>		
Multiplicity	0..1		
Type	EcucBooleanParamDef		
Default value	false		
Post-Build Variant Multiplicity	true		
Post-Build Variant Value	true		
Multiplicity Configuration Class	Pre-compile time	X	VARIANT-PRE-COMPILE
	Link time	–	
	Post-build time	X	VARIANT-POST-BUILD
Value Configuration Class	Pre-compile time	X	VARIANT-PRE-COMPILE
	Link time	–	
	Post-build time	X	VARIANT-POST-BUILD
Scope / Dependency	scope: ECU dependency: This parameter shall not be set to true if ComCancellationSupport is set to false		

SWS Item	[ECUC_Com_00493]		
Parameter Name	ComIPduDirection		
Parent Container	ComIPdu		
Description	The direction defines if this I-PDU, and therefore the contributing signals and signal groups, shall be sent or received.		
Multiplicity	1		
Type	EcucEnumerationParamDef		
Range	RECEIVE	–	
	SEND	–	
Post-Build Variant Value	false		
Value Configuration Class	Pre-compile time	X	VARIANT-PRE-COMPILE
	Link time	X	VARIANT-LINK-TIME, VARIANT-POST-BUILD
	Post-build time	–	
Scope / Dependency	scope: local dependency: If configured to Sent also a ComTxIpdu container shall be included, see ECUC_Com_00496		

SWS Item	[ECUC_Com_00175]		
Parameter Name	ComIPduHandleId		
Parent Container	ComIPdu		





Description	The numerical value used as the ID of this I-PDU. The ComIPduHandleId is required by the API calls Com_RxIndication, Com_TpRxIndication, Com_StartOfReception and Com_CopyRxData to receive I-PDUs from the PduR (ComIP-duDirection: Receive), as well as the PduId passed to an Rx-I-PDU-callout. For Tx-I-PDUs (ComIPduDirection: Send), this handle Id is used for the APIs calls Com_TxConfirmation, Com_TriggerTransmit, Com_TriggerIPDUSend or Com_TriggerIPDUSendWithMetaData, Com_CopyTxData and Com_TpTxConfirmation to transmit respectively confirm transmissions of I-PDUs, as well as the PduId passed to the Tx-I-PDU-callout configured with ComIPduCallout and/or ComIPduTriggerTransmitCallout.		
Multiplicity	0..1		
Type	EcucIntegerParamDef (Symbolic Name generated for this parameter)		
Range	0 .. 65535		
Default value	-		
Post-Build Variant Multiplicity	false		
Post-Build Variant Value	false		
Multiplicity Configuration Class	Pre-compile time	X	All Variants
	Link time	-	
	Post-build time	-	
Value Configuration Class	Pre-compile time	X	All Variants
	Link time	-	
	Post-build time	-	
Scope / Dependency	scope: ECU		

SWS Item	[ECUC_Com_00119]		
Parameter Name	ComIPduSignalProcessing		
Parent Container	ComIPdu		
Description	For the definition of the two modes Immediate and Deferred.		
Multiplicity	1		
Type	EcucEnumerationParamDef		
Range	DEFERRED	signal indication / confirmations are deferred for example to a cyclic task	
	IMMEDIATE	the signal indications / confirmations are performed in Com_RxIndication/ Com_Tx Confirmation	
Post-Build Variant Value	true		
Value Configuration Class	Pre-compile time	X	VARIANT-PRE-COMPILE
	Link time	X	VARIANT-LINK-TIME
	Post-build time	X	VARIANT-POST-BUILD
Scope / Dependency	scope: local		

SWS Item	[ECUC_Com_00765]		
Parameter Name	ComIPduTriggerTransmitCallout		
Parent Container	ComIPdu		
Description	If there is a trigger transmit callout defined for this I-PDU this parameter contains the name of the callout function.		
Multiplicity	0..1		
Type	EcucFunctionNameDef		
Default value	-		
Regular Expression	-		
Post-Build Variant Multiplicity	false		





Post-Build Variant Value	false		
Multiplicity Configuration Class	Pre-compile time	X	All Variants
	Link time	–	
	Post-build time	–	
Value Configuration Class	Pre-compile time	X	All Variants
	Link time	–	
	Post-build time	–	
Scope / Dependency	scope: local		

SWS Item	[ECUC_Com_00761]		
Parameter Name	ComIPduType		
Parent Container	ComIPdu		
Description	Defines if this I-PDU is a normal I-PDU that can be sent unfragmented or if this is a large I-PDU that shall be sent via the Transport Protocol of the underlying bus.		
Multiplicity	1		
Type	EcucEnumerationParamDef		
Range	NORMAL	sent or received via normal L-PDU	
	TP	sent or received via TP	
Post-Build Variant Value	true		
Value Configuration Class	Pre-compile time	X	VARIANT-PRE-COMPILE
	Link time	X	VARIANT-LINK-TIME
	Post-build time	X	VARIANT-POST-BUILD
Scope / Dependency	scope: local		

SWS Item	[ECUC_Com_00206]		
Parameter Name	ComIPduGroupRef		
Parent Container	ComIPdu		
Description	Reference to the I-PDU groups this I-PDU belongs to.		
Multiplicity	0..*		
Type	Reference to ComIPduGroup		
Post-Build Variant Multiplicity	true		
Post-Build Variant Value	true		
Multiplicity Configuration Class	Pre-compile time	X	VARIANT-PRE-COMPILE
	Link time	X	VARIANT-LINK-TIME
	Post-build time	X	VARIANT-POST-BUILD
Value Configuration Class	Pre-compile time	X	VARIANT-PRE-COMPILE
	Link time	X	VARIANT-LINK-TIME
	Post-build time	X	VARIANT-POST-BUILD
Scope / Dependency	scope: local		

SWS Item	[ECUC_Com_10012]		
Parameter Name	ComIPduMainFunctionRef		
Parent Container	ComIPdu		
Description	Reference to the Com_MainFunctionRx/Com_MainFunctionTx this I-PDU belongs to. Mandatory, if multiple main functions of the relevant type are defined.		
Multiplicity	0..1		
Type	Choice reference to [ComMainFunctionRx , ComMainFunctionTx]		





Post-Build Variant Multiplicity	false		
Post-Build Variant Value	false		
Multiplicity Configuration Class	Pre-compile time	X	All Variants
	Link time	–	
	Post-build time	–	
Value Configuration Class	Pre-compile time	X	All Variants
	Link time	–	
	Post-build time	–	
Scope / Dependency	scope: local		

SWS Item	[ECUC_Com_00519]		
Parameter Name	ComIPduSignalGroupRef		
Parent Container	ComIPdu		
Description	References to all signal groups contained in this I-Pdu		
Multiplicity	0..*		
Type	Reference to ComSignalGroup		
Post-Build Variant Multiplicity	true		
Post-Build Variant Value	true		
Multiplicity Configuration Class	Pre-compile time	X	VARIANT-PRE-COMPILE
	Link time	X	VARIANT-LINK-TIME
	Post-build time	X	VARIANT-POST-BUILD
Value Configuration Class	Pre-compile time	X	VARIANT-PRE-COMPILE
	Link time	X	VARIANT-LINK-TIME
	Post-build time	X	VARIANT-POST-BUILD
Scope / Dependency	scope: local		

SWS Item	[ECUC_Com_00518]		
Parameter Name	ComIPduSignalRef		
Parent Container	ComIPdu		
Description	References to all signals contained in this I-PDU.		
Multiplicity	0..*		
Type	Reference to ComSignal		
Post-Build Variant Multiplicity	true		
Post-Build Variant Value	true		
Multiplicity Configuration Class	Pre-compile time	X	VARIANT-PRE-COMPILE
	Link time	X	VARIANT-LINK-TIME
	Post-build time	X	VARIANT-POST-BUILD
Value Configuration Class	Pre-compile time	X	VARIANT-PRE-COMPILE
	Link time	X	VARIANT-LINK-TIME
	Post-build time	X	VARIANT-POST-BUILD
Scope / Dependency	scope: local		

SWS Item	[ECUC_Com_10021]		
Parameter Name	ComMainFunctionRouteSignalsRef		
Parent Container	ComIPdu		





Description	Reference to ComMainFunctionRouteSignals which performs signal gateway related activities.		
Multiplicity	0..1		
Type	Reference to ComMainFunctionRouteSignals		
Post-Build Variant Multiplicity	false		
Post-Build Variant Value	false		
Multiplicity Configuration Class	Pre-compile time	X	All Variants
	Link time	–	
	Post-build time	–	
Value Configuration Class	Pre-compile time	X	All Variants
	Link time	–	
	Post-build time	–	
Scope / Dependency	scope: local		

SWS Item	[ECUC_Com_00711]		
Parameter Name	ComPduldRef		
Parent Container	ComIPdu		
Description	Reference to the "global" Pdu structure to allow harmonization of handle IDs in the COM-Stack.		
Multiplicity	1		
Type	Reference to Pdu		
Post-Build Variant Value	false		
Value Configuration Class	Pre-compile time	X	VARIANT-PRE-COMPILE
	Link time	X	VARIANT-LINK-TIME, VARIANT-POST-BUILD
	Post-build time	–	
Scope / Dependency			

Included Containers		
Container Name	Multiplicity	Scope / Dependency
ComTxIPdu	0..1	This container must be included if COM_IPDU_DIRECTION is configured to SEND.

C.8.5 ComSignal

SWS Item	[ECUC_Com_00344]		
Container Name	ComSignal		
Parent Container	ComConfig		
Description	Contains the configuration parameters of the AUTOSAR COM module's signals.		
Post-Build Variant Multiplicity	true		
Multiplicity Configuration Class	Pre-compile time	X	VARIANT-PRE-COMPILE
	Link time	X	VARIANT-LINK-TIME
	Post-build time	X	VARIANT-POST-BUILD
Configuration Parameters			

SWS Item	[ECUC_Com_00259]		
Parameter Name	ComBitPosition		
Parent Container	ComSignal		
Description	Starting position within the I-PDU. This parameter refers to the position in the I-PDU and not in the shadow buffer. If the endianness conversion is configured to Opaque the parameter ComBitPosition shall define the bit0 of the first byte like in little endian byte order		
Multiplicity	1		
Type	EcucIntegerParamDef		
Range	0 .. 4294967295		
Default value	-		
Post-Build Variant Value	true		
Value Configuration Class	Pre-compile time	X	VARIANT-PRE-COMPILE
	Link time	X	VARIANT-LINK-TIME
	Post-build time	X	VARIANT-POST-BUILD
Scope / Dependency	scope: local		

SWS Item	[ECUC_Com_00158]		
Parameter Name	ComBitSize		
Parent Container	ComSignal		
Description	Size in bits, for integer signal types. For ComSignalType UINT8_N and UINT8_DYN the size shall be configured by ComSignalLength. For ComSignalTypes FLOAT32 and FLOAT64 the size is already defined by the signal type and therefore may be omitted.		
Multiplicity	0..1		
Type	EcucIntegerParamDef		
Range	0 .. 64		
Default value	-		
Post-Build Variant Multiplicity	true		
Post-Build Variant Value	true		
Multiplicity Configuration Class	Pre-compile time	X	VARIANT-PRE-COMPILE
	Link time	X	VARIANT-LINK-TIME
	Post-build time	X	VARIANT-POST-BUILD
Value Configuration Class	Pre-compile time	X	VARIANT-PRE-COMPILE
	Link time	X	VARIANT-LINK-TIME
	Post-build time	X	VARIANT-POST-BUILD
Scope / Dependency	scope: local		

SWS Item	[ECUC_Com_00314]		
Parameter Name	ComDataInvalidAction		
Parent Container	ComSignal		
Description	This parameter defines the action performed upon reception of an invalid signal. Relating to signal groups the action in case if one of the included signals is an invalid signal. If Replace is used the ComSignalInitValue will be used for the replacement.		
Multiplicity	0..1		
Type	EcucEnumerationParamDef		
Range	NOTIFY		-
	REPLACE		Literal for DataInvalidAction
Post-Build Variant Multiplicity	false		
Post-Build Variant Value	false		





Multiplicity Configuration Class	Pre-compile time	X	VARIANT-PRE-COMPILE
	Link time	X	VARIANT-LINK-TIME, VARIANT-POST-BUILD
	Post-build time	–	
Value Configuration Class	Pre-compile time	X	VARIANT-PRE-COMPILE
	Link time	X	VARIANT-LINK-TIME, VARIANT-POST-BUILD
	Post-build time	–	
Scope / Dependency	scope: local		

SWS Item	[ECUC_Com_00183]		
Parameter Name	ComFirstTimeout		
Parent Container	ComSignal		
Description	Defines the length of the first deadline monitoring timeout period in seconds. This timeout is used immediately after start (or restart) of the deadline monitoring service. The timeout period of the successive periods is configured by ECUC_Com_00263.		
Multiplicity	0..1		
Type	EcucFloatParamDef		
Range	[0 .. 3600]		
Default value	–		
Post-Build Variant Multiplicity	true		
Post-Build Variant Value	true		
Multiplicity Configuration Class	Pre-compile time	X	VARIANT-PRE-COMPILE
	Link time	X	VARIANT-LINK-TIME
	Post-build time	X	VARIANT-POST-BUILD
Value Configuration Class	Pre-compile time	X	VARIANT-PRE-COMPILE
	Link time	X	VARIANT-LINK-TIME
	Post-build time	X	VARIANT-POST-BUILD
Scope / Dependency	scope: local		

SWS Item	[ECUC_Com_00165]		
Parameter Name	ComHandleId		
Parent Container	ComSignal		
Description	The numerical value used as the ID. This ID identifies signals and signal groups in the COM APIs using Com_SignalIdType or Com_SignalGroupIdType parameter respectively.		
Multiplicity	0..1		
Type	EcucIntegerParamDef (Symbolic Name generated for this parameter)		
Range	0 .. 65535		
Default value	–		
Post-Build Variant Multiplicity	false		
Post-Build Variant Value	false		
Multiplicity Configuration Class	Pre-compile time	X	All Variants
	Link time	–	
	Post-build time	–	
Value Configuration Class	Pre-compile time	X	All Variants
	Link time	–	
	Post-build time	–	





Scope / Dependency	scope: ECU
---------------------------	------------

SWS Item	[ECUC_Com_00811]		
Parameter Name	ComInitialValueOnly		
Parent Container	ComSignal		
Description	This parameter defines that the respective signal's initial value shall be put into the respective PDU but there will not be any update of the value through the users (e.g. RTE, SwCluC). Thus the Com implementation does not need to expect any API calls for this signal (group).		
Multiplicity	0..1		
Type	EcucBooleanParamDef		
Default value	false		
Post-Build Variant Multiplicity	false		
Post-Build Variant Value	false		
Multiplicity Configuration Class	Pre-compile time	X	VARIANT-PRE-COMPILE
	Link time	X	VARIANT-LINK-TIME, VARIANT-POST-BUILD
	Post-build time	–	
Value Configuration Class	Pre-compile time	X	VARIANT-PRE-COMPILE
	Link time	X	VARIANT-LINK-TIME, VARIANT-POST-BUILD
	Post-build time	–	
Scope / Dependency	scope: local		

SWS Item	[ECUC_Com_00412]		
Parameter Name	ComRxDataTimeoutAction		
Parent Container	ComSignal		
Description	This parameter defines the action performed upon expiration of the reception deadline monitoring timer.		
Multiplicity	0..1		
Type	EcucEnumerationParamDef		
Range	NONE	no replacement shall take place	
	REPLACE	signals shall be replaced by their ComSignalInit Value	
	SUBSTITUTE	signals shall be replaced by their ComTimeout SubstitutionValue	
Post-Build Variant Multiplicity	false		
Post-Build Variant Value	false		
Multiplicity Configuration Class	Pre-compile time	X	VARIANT-PRE-COMPILE
	Link time	X	VARIANT-LINK-TIME, VARIANT-POST-BUILD
	Post-build time	–	
Value Configuration Class	Pre-compile time	X	VARIANT-PRE-COMPILE
	Link time	X	VARIANT-LINK-TIME, VARIANT-POST-BUILD
	Post-build time	–	
Scope / Dependency	scope: local		

SWS Item	[ECUC_Com_00391]		
Parameter Name	ComSignalDataInvalidValue		
Parent Container	ComSignal		
Description	<p>Defines the data invalid value of the signal.</p> <p>In case the ComSignalType is UINT8, UINT16, UINT32, UINT64, SINT8, SINT16, SINT32, SINT64 the string shall be interpreted as defined in the chapter Integer Type in the AUTOSAR EcuC specification. In case the ComSignalType is FLOAT32, FLOAT64 the string shall be interpreted as defined in the chapter Float Type in the AUTOSAR EcuC specification. In case the ComSignalType is BOOLEAN the string shall be interpreted as defined in the chapter Boolean Type in the AUTOSAR EcuC specification. In case the ComSignal is a UINT8_N, UINT8_DYN the string shall be interpreted as a decimal representation of the characters separated by blanks, e.g. "97 98 100" means a string "abd", where the char "a" is in byte 0(lowest address), "b" is in byte 1, and "d" is in byte 2 and (highest address). For the ComSignalType UINT8_DYN the dynamic length shall be set to the number of configured characters. An empty string "" shall be interpreted as 0-sized dynamic signal.</p>		
Multiplicity	0..1		
Type	EcucStringParamDef		
Default value	-		
Regular Expression	-		
Post-Build Variant Multiplicity	false		
Post-Build Variant Value	false		
Multiplicity Configuration Class	Pre-compile time	X	VARIANT-PRE-COMPILE
	Link time	X	VARIANT-LINK-TIME, VARIANT-POST-BUILD
	Post-build time	-	
Value Configuration Class	Pre-compile time	X	VARIANT-PRE-COMPILE
	Link time	X	VARIANT-LINK-TIME, VARIANT-POST-BUILD
	Post-build time	-	
Scope / Dependency	scope: local dependency: In case of UINT8_N the length of ComSignalDataInvalidValue has to be the same as ComSignalLength.		

SWS Item	[ECUC_Com_00157]		
Parameter Name	ComSignalEndianness		
Parent Container	ComSignal		
Description	Defines the endianness of the signal's network representation.		
Multiplicity	1		
Type	EcucEnumerationParamDef		
Range	BIG_ENDIAN	-	
	LITTLE_ENDIAN	-	
	OPAQUE	-	
Post-Build Variant Value	true		
Value Configuration Class	Pre-compile time	X	VARIANT-PRE-COMPILE
	Link time	X	VARIANT-LINK-TIME
	Post-build time	X	VARIANT-POST-BUILD
Scope / Dependency	scope: local		

SWS Item	[ECUC_Com_00170]		
Parameter Name	ComSignalInitValue		
Parent Container	ComSignal		
Description	<p>Initial value for this signal. In case of UINT8_N the default value is a string of length ComSignalLength with all bytes set to 0x00. In case of UINT8_DYN the initial size shall be 0.</p> <p>In case the ComSignalType is UINT8, UINT16, UINT32, UINT64, SINT8, SINT16, SINT32, SINT64 the string shall be interpreted as defined in the chapter Integer Type in the AUTOSAR EcuC specification. In case the ComSignalType is FLOAT32, FLOAT64 the string shall be interpreted as defined in the chapter Float Type in the AUTOSAR EcuC specification. In case the ComSignalType is BOOLEAN the string shall be interpreted as defined in the chapter Boolean Type in the AUTOSAR EcuC specification. In case the ComSignal is a UINT8_N, UINT8_DYN the string shall be interpreted as a decimal representation of the characters separated by blanks, e.g. "97 98 100" means a string "abd", where the char "a" is in byte 0(lowest address), "b" is in byte 1, and "d" is in byte 2 and (highest address). For the ComSignalType UINT8_DYN the dynamic length shall be set to the number of configured characters. An empty string "" shall be interpreted as 0-sized dynamic signal.</p>		
Multiplicity	0..1		
Type	EcucStringParamDef		
Default value	0		
Regular Expression	-		
Post-Build Variant Multiplicity	true		
Post-Build Variant Value	true		
Multiplicity Configuration Class	Pre-compile time	X	VARIANT-PRE-COMPILE
	Link time	X	VARIANT-LINK-TIME
	Post-build time	X	VARIANT-POST-BUILD
Value Configuration Class	Pre-compile time	X	VARIANT-PRE-COMPILE
	Link time	X	VARIANT-LINK-TIME
	Post-build time	X	VARIANT-POST-BUILD
Scope / Dependency	scope: local dependency: In case of UINT8_N the length of ComSignalInitValue has to be the same as ComSignalLength.		

SWS Item	[ECUC_Com_00437]		
Parameter Name	ComSignalLength		
Parent Container	ComSignal		
Description	<p>Description: For ComSignalType UINT8_N this parameter specifies the length n in bytes. For ComSignalType UINT8_DYN it specifies the maximum length in bytes. For all other types this parameter shall be ignored.</p> <p>The supported maximum length is restricted by the used transportation system. For non TP-PDUs the maximum size of a PDU, and therefore also of any included signal, is limited by the concrete bus characteristic. For example, the limit is 8 bytes for CAN and LIN, 64 bytes for CAN FD and 254 for FlexRay.</p>		
Multiplicity	0..1		
Type	EcucIntegerParamDef		
Range	0 .. 4294967295		
Default value	-		
Post-Build Variant Multiplicity	false		
Post-Build Variant Value	false		
Multiplicity Configuration Class	Pre-compile time	X	VARIANT-PRE-COMPILE





	Link time	X	VARIANT-LINK-TIME, VARIANT-POST-BUILD
	Post-build time	–	
Value Configuration Class	Pre-compile time	X	VARIANT-PRE-COMPILE
	Link time	X	VARIANT-LINK-TIME, VARIANT-POST-BUILD
	Post-build time	–	
Scope / Dependency	scope: local		

SWS Item	[ECUC_Com_00127]		
Parameter Name	ComSignalType		
Parent Container	ComSignal		
Description	The AUTOSAR type of the signal. Whether or not the signal is signed or unsigned can be found by examining the value of this attribute. This type could also be used to reserved appropriate storage in AUTOSAR COM.		
Multiplicity	1		
Type	EcucEnumerationParamDef		
Range	BOOLEAN	–	
	FLOAT32	–	
	FLOAT64	–	
	SINT16	–	
	SINT32	–	
	SINT64	–	
	SINT8	–	
	UINT16	–	
	UINT32	–	
	UINT64	–	
	UINT8	–	
	UINT8_DYN	–	
	UINT8_N	–	
Post-Build Variant Value	false		
Value Configuration Class	Pre-compile time	X	VARIANT-PRE-COMPILE
	Link time	X	VARIANT-LINK-TIME, VARIANT-POST-BUILD
	Post-build time	–	
Scope / Dependency	scope: local		

SWS Item	[ECUC_Com_00263]		
Parameter Name	ComTimeout		
Parent Container	ComSignal		
Description	Defines the length of the deadline monitoring timeout period in seconds. The period for the first timeout period can be configured separately by ECUC_Com_00183.		
Multiplicity	0..1		
Type	EcucFloatParamDef		
Range	[0 .. 3600]		
Default value	–		
Post-Build Variant Multiplicity	true		
Post-Build Variant Value	true		
Multiplicity Configuration Class	Pre-compile time	X	VARIANT-PRE-COMPILE





Value Configuration Class	Link time	X	VARIANT-LINK-TIME
	Post-build time	X	VARIANT-POST-BUILD
	Pre-compile time	X	VARIANT-PRE-COMPILE
	Link time	X	VARIANT-LINK-TIME
	Post-build time	X	VARIANT-POST-BUILD
Scope / Dependency	scope: local		

SWS Item	[ECUC_Com_10006]		
Parameter Name	ComTimeoutSubstitutionValue		
Parent Container	ComSignal		
Description	<p>The signal substitution value will be used in case of a timeout and ComRxDataTimeout Action is set to SUBSTITUTE. In case of UINT8_N the default value is a string of length ComSignalLength with all bytes set to 0x00.</p> <p>In case of UINT8_DYN the initial size shall be 0.</p> <p>In case the ComSignalType is UINT8, UINT16, UINT32, UINT64, SINT8, SINT16, SINT32, SINT64 the string shall be interpreted as defined in the chapter Integer Type in the AUTOSAR EcuC specification.</p> <p>In case the ComSignalType is FLOAT32, FLOAT64 the string shall be interpreted as defined in the chapter Float Type in the AUTOSAR EcuC specification.</p> <p>In case the ComSignalType is BOOLEAN the string shall be interpreted as defined in the chapter Boolean Type in the AUTOSAR EcuC specification.</p> <p>In case the ComSignal is a UINT8_N, UINT8_DYN the string shall be interpreted as a decimal representation of the characters separated by blanks, e.g. "97 98 100" means a string "abd", where the char "a" is in byte 0(lowest address), "b" is in byte 1, and "d" is in byte 2 and (highest address). For the ComSignalType UINT8_DYN the dynamic length shall be set to the number of configured characters. An empty string "" shall be interpreted as 0-sized dynamic signal.</p>		
Multiplicity	0..1		
Type	EcucStringParamDef		
Default value	-		
Regular Expression	-		
Post-Build Variant Multiplicity	true		
Post-Build Variant Value	true		
Multiplicity Configuration Class	Pre-compile time	X	VARIANT-PRE-COMPILE
	Link time	X	VARIANT-LINK-TIME
	Post-build time	X	VARIANT-POST-BUILD
Value Configuration Class	Pre-compile time	X	VARIANT-PRE-COMPILE
	Link time	X	VARIANT-LINK-TIME
	Post-build time	X	VARIANT-POST-BUILD
Scope / Dependency	scope: local		

SWS Item	[ECUC_Com_00232]		
Parameter Name	ComTransferProperty		
Parent Container	ComSignal		
Description	<p>Defines if a write access to this signal can trigger the transmission of the corresponding I-PDU. If the I-PDU is triggered, depends also on the transmission mode of the corresponding I-PDU.</p>		
Multiplicity	0..1		
Type	EcucEnumerationParamDef		





Range	PENDING	A write access to this signal never triggers the transmission of the corresponding I-PDU.	
	TRIGGERED	Depending on the transmission mode, a write access to this signal can trigger the transmission of the corresponding I-PDU.	
	TRIGGERED_ON_CHANGE	Depending on the transmission mode, a write access to this signal can trigger the transmission of the corresponding I-PDU, but only in case the written value is different to the locally stored (last sent or initial value) in length or value.	
	TRIGGERED_ON_CHANGE_WITHOUT_REPETITION	Depending on the transmission mode, a write access to this signal can trigger the transmission of the corresponding I-PDU just once without a repetition, but only in case the written value is different to the locally stored (last sent or initial value) in length or value.	
	TRIGGERED_WITHOUT_REPETITION	Depending on the transmission mode, a write access to this signal can trigger the transmission of the corresponding I-PDU just once without a repetition.	
Post-Build Variant Multiplicity	true		
Post-Build Variant Value	true		
Multiplicity Configuration Class	Pre-compile time	X	VARIANT-PRE-COMPILE
	Link time	X	VARIANT-LINK-TIME
	Post-build time	X	VARIANT-POST-BUILD
Value Configuration Class	Pre-compile time	X	VARIANT-PRE-COMPILE
	Link time	X	VARIANT-LINK-TIME
	Post-build time	X	VARIANT-POST-BUILD
Scope / Dependency	scope: local		

SWS Item	[ECUC_Com_00257]		
Parameter Name	ComUpdateBitPosition		
Parent Container	ComSignal		
Description	Bit position of update-bit inside I-PDU. If this attribute is omitted then there is no update-bit. This setting must be consistently on sender and on receiver side. Range: 0..63 for CAN and LIN, 0..511 for CAN FD, 0..2031 for FlexRay, 0..4294967295 for TP.		
Multiplicity	0..1		
Type	EcucIntegerParamDef		
Range	0 .. 4294967295		
Default value	-		
Post-Build Variant Multiplicity	true		
Post-Build Variant Value	true		
Multiplicity Configuration Class	Pre-compile time	X	VARIANT-PRE-COMPILE
	Link time	X	VARIANT-LINK-TIME
	Post-build time	X	VARIANT-POST-BUILD
Value Configuration Class	Pre-compile time	X	VARIANT-PRE-COMPILE
	Link time	X	VARIANT-LINK-TIME
	Post-build time	X	VARIANT-POST-BUILD
Scope / Dependency	scope: local		

SWS Item	[ECUC_Com_00002]		
Parameter Name	ComSystemTemplateSystemSignalRef		
Parent Container	ComSignal		
Description	Reference to the ISignalToIPduMapping that contains a reference to the ISignal (System Template) which this ComSignal (or ComGroupSignal) represents.		
Multiplicity	0..1		
Type	Foreign reference to I-SIGNAL-TO-I-PDU-MAPPING		
Post-Build Variant Multiplicity	true		
Post-Build Variant Value	true		
Multiplicity Configuration Class	Pre-compile time	X	VARIANT-PRE-COMPILE
	Link time	X	VARIANT-LINK-TIME
	Post-build time	X	VARIANT-POST-BUILD
Value Configuration Class	Pre-compile time	X	VARIANT-PRE-COMPILE
	Link time	X	VARIANT-LINK-TIME
	Post-build time	X	VARIANT-POST-BUILD
Scope / Dependency	scope: ECU		

Included Containers		
Container Name	Multiplicity	Scope / Dependency
ComFilter	0..1	This container contains the configuration parameters of the AUTOSAR COM module's Filters. Note: On sender side the container is used to specify the transmission mode conditions.

C.8.6 ComUserModule

SWS Item	[ECUC_Com_10031]		
Container Name	ComUserModule		
Parent Container	ComConfig		
Description	Contains the configuration parameters of the Com user modules. Tags: atp.Status=draft		
Post-Build Variant Multiplicity	false		
Multiplicity Configuration Class	Pre-compile time	X	All Variants
	Link time	–	
	Post-build time	–	
Configuration Parameters			

SWS Item	[ECUC_Com_10029]		
Parameter Name	ComUserModuleCnfRef		
Parent Container	ComUserModule		
Description	Reference to the Com user module configuration. Tags: atp.Status=draft		
Multiplicity	1		
Type	Reference to destinationUri ComUserUriDefSet/ComUser		
Post-Build Variant Multiplicity	false		





Post-Build Variant Value	false		
Value Configuration Class	Pre-compile time	X	All Variants
	Link time	–	
	Post-build time	–	
Scope / Dependency	scope: ECU		

No Included Containers

C.8.7 ComUserUriDefSet

SWS Item	[ECUC_Com_10039]
EcucDestinationUriDefSet Name	ComUserUriDefSet
Description	Defines the set of DestinationUriDefs for the Com module.
Included EcucDestinationUriDefs	
Name	Description
ComUser	Defines the configuration container content of the Com user modules relevant settings.

SWS Item	[ECUC_Com_10040]
EcucDestinationUriDef Name	ComUser
Destination Uri Definition Set	ComUserUriDefSet
Description	Defines the configuration container content of the Com user modules relevant settings.
destinationUriNestingContract	vertexOfTargetContainer
Configuration Parameters	

Included Containers		
Container Name	Multiplicity	Scope / Dependency
ComUserModuleCnf	0..1	Contains the configuration parameters of the Com user module. Tags: atp.Status=draft

C.8.8 ComSignalGroup

SWS Item	[ECUC_Com_00345]		
Container Name	ComSignalGroup		
Parent Container	ComConfig		
Description	Contains the configuration parameters of the AUTOSAR COM module's signal groups.		
Post-Build Variant Multiplicity	true		
Multiplicity Configuration Class	Pre-compile time	X	VARIANT-PRE-COMPILE
	Link time	X	VARIANT-LINK-TIME
	Post-build time	X	VARIANT-POST-BUILD





Configuration Parameters

SWS Item	[ECUC_Com_00314]		
Parameter Name	ComDataInvalidAction		
Parent Container	ComSignalGroup		
Description	This parameter defines the action performed upon reception of an invalid signal. Relating to signal groups the action in case if one of the included signals is an invalid signal. If Replace is used the ComSignalInitValue will be used for the replacement.		
Multiplicity	0..1		
Type	EcucEnumerationParamDef		
Range	NOTIFY	–	
	REPLACE	Literal for DataInvalidAction	
Post-Build Variant Multiplicity	false		
Post-Build Variant Value	false		
Multiplicity Configuration Class	Pre-compile time	X	VARIANT-PRE-COMPILE
	Link time	X	VARIANT-LINK-TIME, VARIANT-POST-BUILD
	Post-build time	–	
Value Configuration Class	Pre-compile time	X	VARIANT-PRE-COMPILE
	Link time	X	VARIANT-LINK-TIME, VARIANT-POST-BUILD
	Post-build time	–	
Scope / Dependency	scope: local		

SWS Item	[ECUC_Com_00183]		
Parameter Name	ComFirstTimeout		
Parent Container	ComSignalGroup		
Description	Defines the length of the first deadline monitoring timeout period in seconds. This timeout is used immediately after start (or restart) of the deadline monitoring service. The timeout period of the successive periods is configured by ECUC_Com_00263.		
Multiplicity	0..1		
Type	EcucFloatParamDef		
Range	[0 .. 3600]		
Default value	–		
Post-Build Variant Multiplicity	true		
Post-Build Variant Value	true		
Multiplicity Configuration Class	Pre-compile time	X	VARIANT-PRE-COMPILE
	Link time	X	VARIANT-LINK-TIME
	Post-build time	X	VARIANT-POST-BUILD
Value Configuration Class	Pre-compile time	X	VARIANT-PRE-COMPILE
	Link time	X	VARIANT-LINK-TIME
	Post-build time	X	VARIANT-POST-BUILD
Scope / Dependency	scope: local		

SWS Item	[ECUC_Com_00165]		
Parameter Name	ComHandleId		
Parent Container	ComSignalGroup		





Description	The numerical value used as the ID. This ID identifies signals and signal groups in the COM APIs using Com_SignalIdType or Com_SignalGroupIdType parameter respectively.		
Multiplicity	0..1		
Type	EcucIntegerParamDef (Symbolic Name generated for this parameter)		
Range	0 .. 65535		
Default value	-		
Post-Build Variant Multiplicity	false		
Post-Build Variant Value	false		
Multiplicity Configuration Class	Pre-compile time	X	All Variants
	Link time	-	
	Post-build time	-	
Value Configuration Class	Pre-compile time	X	All Variants
	Link time	-	
	Post-build time	-	
Scope / Dependency	scope: ECU		

SWS Item	[ECUC_Com_00811]		
Parameter Name	ComInitialValueOnly		
Parent Container	ComSignalGroup		
Description	This parameter defines that the respective signal's initial value shall be put into the respective PDU but there will not be any update of the value through the users (e.g. RTE, SwCluC). Thus the Com implementation does not need to expect any API calls for this signal (group).		
Multiplicity	0..1		
Type	EcucBooleanParamDef		
Default value	false		
Post-Build Variant Multiplicity	false		
Post-Build Variant Value	false		
Multiplicity Configuration Class	Pre-compile time	X	VARIANT-PRE-COMPILE
	Link time	X	VARIANT-LINK-TIME, VARIANT-POST-BUILD
	Post-build time	-	
Value Configuration Class	Pre-compile time	X	VARIANT-PRE-COMPILE
	Link time	X	VARIANT-LINK-TIME, VARIANT-POST-BUILD
	Post-build time	-	
Scope / Dependency	scope: local		

SWS Item	[ECUC_Com_00412]		
Parameter Name	ComRxDataTimeoutAction		
Parent Container	ComSignalGroup		
Description	This parameter defines the action performed upon expiration of the reception deadline monitoring timer.		
Multiplicity	0..1		
Type	EcucEnumerationParamDef		
Range	NONE	no replacement shall take place	
	REPLACE	signals shall be replaced by their ComSignalInit Value	





	SUBSTITUTE	signals shall be replaced by their ComTimeout SubstitutionValue	
Post-Build Variant Multiplicity	false		
Post-Build Variant Value	false		
Multiplicity Configuration Class	Pre-compile time	X	VARIANT-PRE-COMPILE
	Link time	X	VARIANT-LINK-TIME, VARIANT-POST-BUILD
	Post-build time	–	
Value Configuration Class	Pre-compile time	X	VARIANT-PRE-COMPILE
	Link time	X	VARIANT-LINK-TIME, VARIANT-POST-BUILD
	Post-build time	–	
Scope / Dependency	scope: local		

SWS Item	[ECUC_Com_10003]		
Parameter Name	ComSignalGroupArrayAccess		
Parent Container	ComSignalGroup		
Description	Defines whether the uint8-array based access shall be used for this ComSignalGroup.		
Multiplicity	0..1		
Type	EcucBooleanParamDef		
Default value	–		
Post-Build Variant Multiplicity	false		
Post-Build Variant Value	false		
Multiplicity Configuration Class	Pre-compile time	X	All Variants
	Link time	–	
	Post-build time	–	
Value Configuration Class	Pre-compile time	X	All Variants
	Link time	–	
	Post-build time	–	
Scope / Dependency			

SWS Item	[ECUC_Com_00263]		
Parameter Name	ComTimeout		
Parent Container	ComSignalGroup		
Description	Defines the length of the deadline monitoring timeout period in seconds. The period for the first timeout period can be configured separately by ECUC_Com_00183.		
Multiplicity	0..1		
Type	EcucFloatParamDef		
Range	[0 .. 3600]		
Default value	–		
Post-Build Variant Multiplicity	true		
Post-Build Variant Value	true		
Multiplicity Configuration Class	Pre-compile time	X	VARIANT-PRE-COMPILE
	Link time	X	VARIANT-LINK-TIME
	Post-build time	X	VARIANT-POST-BUILD
Value Configuration Class	Pre-compile time	X	VARIANT-PRE-COMPILE
	Link time	X	VARIANT-LINK-TIME
	Post-build time	X	VARIANT-POST-BUILD





Scope / Dependency	scope: local
---------------------------	--------------

SWS Item	[ECUC_Com_00232]		
Parameter Name	ComTransferProperty		
Parent Container	ComSignalGroup		
Description	Defines if a write access to this signal can trigger the transmission of the corresponding I-PDU. If the I-PDU is triggered, depends also on the transmission mode of the corresponding I-PDU.		
Multiplicity	0..1		
Type	EcucEnumerationParamDef		
Range	PENDING	A write access to this signal never triggers the transmission of the corresponding I-PDU.	
	TRIGGERED	Depending on the transmission mode, a write access to this signal can trigger the transmission of the corresponding I-PDU.	
	TRIGGERED_ON_CHANGE	Depending on the transmission mode, a write access to this signal can trigger the transmission of the corresponding I-PDU, but only in case the written value is different to the locally stored (last sent or initial value) in length or value.	
	TRIGGERED_ON_CHANGE_WITHOUT_REPETITION	Depending on the transmission mode, a write access to this signal can trigger the transmission of the corresponding I-PDU just once without a repetition, but only in case the written value is different to the locally stored (last sent or initial value) in length or value.	
	TRIGGERED_WITHOUT_REPETITION	Depending on the transmission mode, a write access to this signal can trigger the transmission of the corresponding I-PDU just once without a repetition.	
Post-Build Variant Multiplicity	true		
Post-Build Variant Value	true		
Multiplicity Configuration Class	Pre-compile time	X	VARIANT-PRE-COMPILE
	Link time	X	VARIANT-LINK-TIME
	Post-build time	X	VARIANT-POST-BUILD
Value Configuration Class	Pre-compile time	X	VARIANT-PRE-COMPILE
	Link time	X	VARIANT-LINK-TIME
	Post-build time	X	VARIANT-POST-BUILD
Scope / Dependency	scope: local		

SWS Item	[ECUC_Com_00257]		
Parameter Name	ComUpdateBitPosition		
Parent Container	ComSignalGroup		
Description	Bit position of update-bit inside I-PDU. If this attribute is omitted then there is no update-bit. This setting must be consistently on sender and on receiver side. Range: 0..63 for CAN and LIN, 0..511 for CAN FD, 0..2031 for FlexRay, 0..4294967295 for TP.		
Multiplicity	0..1		
Type	EcucIntegerParamDef		
Range	0 .. 4294967295		
Default value	-		





Post-Build Variant Multiplicity	true		
Post-Build Variant Value	true		
Multiplicity Configuration Class	Pre-compile time	X	VARIANT-PRE-COMPILE
	Link time	X	VARIANT-LINK-TIME
	Post-build time	X	VARIANT-POST-BUILD
Value Configuration Class	Pre-compile time	X	VARIANT-PRE-COMPILE
	Link time	X	VARIANT-LINK-TIME
	Post-build time	X	VARIANT-POST-BUILD
Scope / Dependency	scope: local		

SWS Item	[ECUC_Com_00001]		
Parameter Name	ComSystemTemplateSignalGroupRef		
Parent Container	ComSignalGroup		
Description	Reference to the ISignalToIPduMapping that contains a reference to the ISignalGroup (SystemTemplate) which this ComSignalGroup represents.		
Multiplicity	0..1		
Type	Foreign reference to I-SIGNAL-TO-I-PDU-MAPPING		
Post-Build Variant Multiplicity	true		
Post-Build Variant Value	true		
Multiplicity Configuration Class	Pre-compile time	X	VARIANT-PRE-COMPILE
	Link time	X	VARIANT-LINK-TIME
	Post-build time	X	VARIANT-POST-BUILD
Value Configuration Class	Pre-compile time	X	VARIANT-PRE-COMPILE
	Link time	X	VARIANT-LINK-TIME
	Post-build time	X	VARIANT-POST-BUILD
Scope / Dependency	scope: ECU		

Included Containers		
Container Name	Multiplicity	Scope / Dependency
ComGroupSignal	0..*	This container contains the configuration parameters of group signals. I.e. signals that are included within a signal group.

C.9 LdCom

SWS Item	[ECUC_LdCom_00001]
Module Name	LdCom
Description	Configuration of the AUTOSAR LdCom module.
Post-Build Variant Support	true
Supported Config Variants	VARIANT-LINK-TIME, VARIANT-POST-BUILD, VARIANT-PRE-COMPILE

Included Containers		
Container Name	Multiplicity	Scope / Dependency
LdComConfig	1	This container contains the configuration parameters and sub containers of the AUTOSAR LdCom module.
LdComGeneral	1	Contains the general configuration parameters of the LdCom module.

C.9.1 LdComConfig

SWS Item	[ECUC_LdCom_00003]
Container Name	LdComConfig
Parent Container	LdCom
Description	This container contains the configuration parameters and sub containers of the AUTOSAR LdCom module.
Configuration Parameters	

Included Containers		
Container Name	Multiplicity	Scope / Dependency
LdComIPdu	0..*	Contains the configuration parameters of the LdCom's signal (IPdu) inside LdCom.
LdComUserModule	0..*	Contains the configuration parameters of the LdCom user modules. Tags: atp.Status=draft

C.9.2 LdComIPdu

SWS Item	[ECUC_LdCom_00006]		
Container Name	LdComIPdu		
Parent Container	LdComConfig		
Description	Contains the configuration parameters of the LdCom's signal (IPdu) inside LdCom.		
Post-Build Variant Multiplicity	true		
Multiplicity Configuration Class	Pre-compile time	X	VARIANT-PRE-COMPILE
	Link time	X	VARIANT-LINK-TIME
	Post-build time	X	VARIANT-POST-BUILD
Configuration Parameters			

SWS Item	[ECUC_LdCom_00002]		
Parameter Name	LdComApiType		
Parent Container	LdComIPdu		
Description	Defines if this I-PDU is a normal I-PDU that shall be sent unfragmented or if this is a large I-PDU that shall be sent via the Transport Protocol of the underlying bus. This setting is used by RTE to invoke the proper API.		
Multiplicity	1		
Type	EcucEnumerationParamDef		
Range	LDCOM_IF	sent or received via interface API.	
	LDCOM_TP	sent or received via transport protocol API.	
Post-Build Variant Value	false		
Value Configuration Class	Pre-compile time	X	VARIANT-PRE-COMPILE
	Link time	X	VARIANT-LINK-TIME, VARIANT-POST-BUILD
	Post-build time	–	
Scope / Dependency	scope: ECU		

SWS Item	[ECUC_LdCom_00005]		
Parameter Name	LdComHandleId		
Parent Container	LdComIPdu		
Description	This is the ID used by the LdCom users (e.g. RTE) to invoke LdCom. A corresponding shortName is created, which is used for the invocations of the users (e.g. RTE). The same ID is used for invocations by PduR.		
Multiplicity	1		
Type	EcucIntegerParamDef (Symbolic Name generated for this parameter)		
Range	0 .. 65535		
Default value	-		
Post-Build Variant Value	false		
Value Configuration Class	Pre-compile time	X	All Variants
	Link time	-	
	Post-build time	-	
Scope / Dependency	scope: ECU		

SWS Item	[ECUC_LdCom_00007]		
Parameter Name	LdComIPduDirection		
Parent Container	LdComIPdu		
Description	The direction defines if this IPdu, and therefore the contributing signal, shall be sent or received.		
Multiplicity	1		
Type	EcucEnumerationParamDef		
Range	LDCOM_RECEIVE	-	
	LDCOM_SEND	-	
Post-Build Variant Value	false		
Value Configuration Class	Pre-compile time	X	VARIANT-PRE-COMPILE
	Link time	X	VARIANT-LINK-TIME, VARIANT-POST-BUILD
	Post-build time	-	
Scope / Dependency	scope: local		

SWS Item	[ECUC_LdCom_00010]		
Parameter Name	LdComPduRef		
Parent Container	LdComIPdu		
Description	Reference to the global Pdu.		
Multiplicity	1		
Type	Reference to Pdu		
Post-Build Variant Value	false		
Value Configuration Class	Pre-compile time	X	VARIANT-PRE-COMPILE
	Link time	X	VARIANT-LINK-TIME, VARIANT-POST-BUILD
	Post-build time	-	
Scope / Dependency	scope: ECU		

SWS Item	[ECUC_LdCom_00011]		
Parameter Name	LdComSystemTemplateSignalRef		
Parent Container	LdComIPdu		





Description	Reference to the ISignalToIPduMapping that contains a reference to the ISignal (System Template).		
Multiplicity	0..1		
Type	Foreign reference to I-SIGNAL-TO-I-PDU-MAPPING		
Post-Build Variant Multiplicity	true		
Post-Build Variant Value	true		
Multiplicity Configuration Class	Pre-compile time	X	VARIANT-PRE-COMPILE
	Link time	X	VARIANT-LINK-TIME
	Post-build time	X	VARIANT-POST-BUILD
Value Configuration Class	Pre-compile time	X	VARIANT-PRE-COMPILE
	Link time	X	VARIANT-LINK-TIME
	Post-build time	X	VARIANT-POST-BUILD
Scope / Dependency	scope: ECU		

No Included Containers

C.9.3 LdComUserModule

SWS Item	[ECUC_LdCom_00029]		
Container Name	LdComUserModule		
Parent Container	LdComConfig		
Description	Contains the configuration parameters of the LdCom user modules. Tags: atp.Status=draft		
Post-Build Variant Multiplicity	false		
Multiplicity Configuration Class	Pre-compile time	X	All Variants
	Link time	–	
	Post-build time	–	
Configuration Parameters			

SWS Item	[ECUC_LdCom_00032]		
Parameter Name	LdComUserModuleCnfRef		
Parent Container	LdComUserModule		
Description	Reference to the LdCom user module configuration. Tags: atp.Status=draft		
Multiplicity	1		
Type	Reference to destinationUri LdComUserUriDefSet/LdComUser		
Post-Build Variant Multiplicity	false		
Post-Build Variant Value	false		
Value Configuration Class	Pre-compile time	X	All Variants
	Link time	–	
	Post-build time	–	
Scope / Dependency	scope: ECU		

No Included Containers

C.9.4 LdComUserUriDefSet

SWS Item	[ECUC_LdCom_00034]
EcucDestinationUriDefSet Name	LdComUserUriDefSet
Description	Defines the set of DestinationUriDefs for the LdCom module.
Included EcucDestinationUriDefs	
Name	Description
LdComUser	Defines the configuration container content of the LdCom user modules relevant settings.

SWS Item	[ECUC_LdCom_00035]
EcucDestinationUriDef Name	LdComUser
Destination Uri Definition Set	LdComUserUriDefSet
Description	Defines the configuration container content of the LdCom user modules relevant settings.
destinationUriNestingContract	vertexOfTargetContainer
Configuration Parameters	

Included Containers		
Container Name	Multiplicity	Scope / Dependency
LdComUserModuleCnf	0..1	Contains the configuration parameters of the LdCom user module. Tags: atp.Status=draft

C.10 WdgM

C.10.1 WdgMTransitionProxy

SWS Item	[ECUC_WdgM_00364]
Container Name	WdgMTransitionProxy
Parent Container	WdgMExternalLogicalSupervision
Description	The WdgMTransitionProxy defines a proxy for a transition between the Host Software Cluster and an Application Software Cluster and vice versa. From the Host Software Cluster perspective a Cross Cluster Transition graph leaves the host after the transition which has the WdgMTransitionProxy as a destination or initial reference and returns in this WdgMTransitionProxy after the configured transitions are occurred in the related Application Software Cluster. Afterwards the transition in the host are expected which are referencing the WdgMTransitionProxy by a source or final reference. Tags: atp.Status=draft
Configuration Parameters	

SWS Item	[ECUC_WdgM_00367]
Parameter Name	WdgMResourceRef
Parent Container	WdgMTransitionProxy





Description	Reference to the CpSoftwareClusterServiceResource. Tags: atp.Status=draft
Multiplicity	1
Type	Foreign reference to CP-SOFTWARE-CLUSTER-SERVICE-RESOURCE
Scope / Dependency	scope: ECU

No Included Containers

C.10.2 WdgMBaseSocket

SWS Item	[ECUC_WdgM_00377]		
Container Name	WdgMBaseSocket		
Parent Container	WdgMGeneral		
Description	<p>This container configures how many EcucPartitions specific infrastructure links are required for the WdgM instances in Application Software Clusters provided by the Host Software Cluster. Such infrastructure links serve for: the initialization of Application Software Cluster WdgM instances by Host WdgM instance the transmission of supervision results from Application Software Cluster WdgM instances to Host WdgM instance any other implementation specific purpose which is need for the interaction of Application Software Cluster WdgM instances and Host WdgM instance</p> <p>If the infrastructure connection is specific to one or several EcucPartition(s) the WdgMSocketEcucPartitionRef(s) denotes the applicable EcucPartition.</p> <p>Tags: atp.Status=draft</p>		
Multiplicity Configuration Class	Pre-compile time	X	All Variants
	Link time	–	
	Post-build time	–	
Configuration Parameters			

SWS Item	[ECUC_WdgM_00378]		
Parameter Name	WdgMResourceRef		
Parent Container	WdgMBaseSocket		
Description	Reference to the CpSoftwareClusterServiceResource. Tags: atp.Status=draft		
Multiplicity	1		
Type	Foreign reference to CP-SOFTWARE-CLUSTER-SERVICE-RESOURCE		
Scope / Dependency	scope: ECU		

SWS Item	[ECUC_WdgM_00366]		
Parameter Name	WdgMSocketEcucPartitionRef		
Parent Container	WdgMBaseSocket		
Description	Reference to the EcucPartition. Tags: atp.Status=draft		
Multiplicity	0..*		
Type	Reference to EcucPartition		
Multiplicity Configuration Class	Pre-compile time	X	All Variants



△

	Link time	-	
	Post-build time	-	
Value Configuration Class	Pre-compile time	X	All Variants
	Link time	-	
	Post-build time	-	
Scope / Dependency	scope: ECU		

No Included Containers

D Referenced C-API

D.1 RTE

D.1.1 Rte_Rips_DatalsUpdated

Service Name	Rte_Rips_<PlugIn>_DatalsUpdated_<SwcBswI>_<CGI> (draft)	
Syntax	boolean Rte_Rips_<PlugIn>_DataIsUpdated_<SwcBswI>_<CGI> (void)	
Service ID [hex]	0xB4	
Sync/Async	Synchronous	
Reentrancy	Reentrant	
Parameters (in)	None	
Parameters (inout)	None	
Parameters (out)	None	
Return value	boolean	The return value is used to indicate if the data has been updated or not.
Description	The Rte_Rips_DatalsUpdated API provides access to the update flag for an explicit receiver Tags: atp.Status=draft	
Available via	Rte_Rips_<PlugIn>_<SwcBswI>.h	

D.1.2 Rte_Rips_DRead

Service Name	Rte_Rips_<PlugIn>_DRead_<SwcBswI>[Partition][_<ExE>]_<CGI>(draft)	
Syntax	<return> Rte_Rips_<PlugIn>_DRead_<SwcBswI> [Partition] [_<ExE>]_<CGI> ([Std_TransformerError transformerError])	
Service ID [hex]	0xFF	
Sync/Async	Synchronous	
Reentrancy	Reentrant	
Parameters (in)	None	
Parameters (inout)	None	
Parameters (out)	transformerError	The OUT parameter transformerError contains the transformer error which occurred during execution of the transformer chain.
Return value	<return>	Return value provides access to the data value of the Variable DataPrototype. For details of the <return> value definition see section 5.2.6.6.
Description	Rte_Rips_DRead Performs an "explicit" read on a sender-receiver communication data element typed by a primitive data type.	
Available via	Rte_Rips_<PlugIn>_<SwcBswI>.h	

D.1.3 Rte_Rips_DatalsUpdated_EventActivation

Service Name	Rte_Rips_<PlugIn>_DatalsUpdatedEventActivation_<SwcBswI>_<DR>_<CGI> (draft)	
Syntax	<pre>boolean Rte_Rips_<PlugIn>_DataIsUpdatedEventActivation_<SwcBswI>_<DR>_<CGI> (void)</pre>	
Service ID [hex]	0xB5	
Sync/Async	Synchronous	
Reentrancy	Reentrant	
Parameters (in)	None	
Parameters (inout)	None	
Parameters (out)	None	
Return value	boolean	The return value is used to indicate if the Runnable shall be activated or not.
Description	<p>The Rte_Rips_DatalsUpdated_EventActivation API indicates the RTE to activate the Runnable Entity triggered by DataReceivedEvent when the related VariableDataPrototype has been updated</p> <p>Tags: atp.Status=draft</p>	
Available via	Rte_Rips_<PlugIn>.h	

D.1.4 Rte_Rips_Feedback

Service Name	Rte_Rips_<PlugIn>_Feedback_[<SwcBswI>][Partition]_<CGI> (draft)	
Syntax	<pre>Std_ReturnType Rte_Rips_<PlugIn>_Feedback_[<SwcBswI>][Partition]_<CGI> (void)</pre>	
Service ID [hex]	0xB6	
Sync/Async	Synchronous	
Reentrancy	Reentrant	
Parameters (in)	None	
Parameters (inout)	None	
Parameters (out)	None	
Return value	Std_ReturnType	The return value is used to pass error notifications.
Description	<p>The Rte_Rips_Feedback API provides access to acknowledgment notifications for explicit and implicit sender-receiver communication and to pass error notification to senders in a Software Cluster</p> <p>Tags: atp.Status=draft</p>	
Available via	Rte_Rips_<PlugIn>_<SwcBswI>.h	

D.1.5 Rte_Rips_Invoke

Service Name	Rte_Rips_<PlugIn>_Invoke_<SwcBswI>_<CGI>(draft)	
Syntax	<pre>Std_ReturnType Rte_Rips_<PlugIn>_Invoke_<SwcBswI>_<CGI> ([IN IN/OUT OUT] <data_1>, [IN IN/OUT OUT] ..., [IN IN/OUT OUT] <data_n>, [Std_TransformerError transformerError])</pre>	
Service ID [hex]	0xEC	
Sync/Async	Synchronous	
Reentrancy	Reentrant	
Parameters (in)	<data_1>	The Rte_Rips_Invoke API includes zero or more IN, IN/OUT and OUT parameters according SWS_Rte_01102 and none in case of triggers
Parameters (inout)	...	The Rte_Rips_Invoke API includes zero or more IN, IN/OUT and OUT parameters according SWS_Rte_01102 and none in case of triggers
Parameters (out)	<data_n>	The Rte_Rips_Invoke API includes zero or more IN, IN/OUT and OUT parameters according SWS_Rte_01102 and none in case of triggers
	transformerError	The OUT parameter transformerError contains the transformer error which occurred during execution of the transformer chain.
Return value	Std_ReturnType	The return value is used to indicate communication errors.
Description	Rte_Rips_Invoke performs a transformer or cross cluster invocation for clients or trigger sources.	
Available via	Rte_Rips_<PlugIn>_<SwcBswI>.h	

D.1.6 Rte_Rips_InvocationHandler

Service Name	<name of the Invocation Handler>
Syntax	<pre>void <name of the Invocation Handler> (void)</pre>
Service ID [hex]	0xEE
Sync/Async	Synchronous
Reentrancy	Conditional Reentrant
Parameters (in)	None
Parameters (inout)	None
Parameters (out)	None
Return value	None
Description	Performs invocation of server runnables, hard error runnables, ASCR runnables and triggered runnables via a transformer".
Available via	Rte_Rips_<PlugIn>.h

D.1.7 Rte_Rips_Prm

Service Name	Rte_Rips_<PlugIn>_Prm_<CGI> (draft)	
Syntax	<return> Rte_Rips_<PlugIn>_Prm_<CGI> (void)	
Service ID [hex]	0x100	
Sync/Async	Synchronous	
Reentrancy	Reentrant	
Parameters (in)	None	
Parameters (inout)	None	
Parameters (out)	None	
Return value	<return>	For primitive data types, the Rte_Rips_Prm API returns the parameter value. For composite data types, the Rte_Rips_Prm API returns a reference (in C, a pointer) to the constant parameter.
Description	The Rte_Rips_Prm API provides access to a parameter provided by another Software Cluster Tags: atp.Status=draft	
Available via	Rte_Rips_<PlugIn>_<SwcBswl>.h	

D.1.8 Rte_Rips_Read

Service Name	Rte_Rips_<PlugIn>_Read_<SwcBswl>[Partition][_<ExE>]_<CGI>(draft)	
Syntax	Std_ReturnType Rte_Rips_<PlugIn>_Read_<SwcBswl> [Partition] [_<ExE>]_<CGI> (OUT <data>, [Std_TransformerError transformerError])	
Service ID [hex]	0xEA	
Sync/Async	Synchronous	
Reentrancy	Reentrant	
Parameters (in)	None	
Parameters (inout)	None	
Parameters (out)	<data>	The OUT parameter <data> pass back the received data.
	transformerError	The OUT parameter transformerError contains the transformer error which occurred during execution of the transformer chain.
Return value	Std_ReturnType	The return value is used to indicate communication errors.
Description	Rte_Rips_Read Performs an "explicit" read on a sender-receiver communication data element.	
Available via	Rte_Rips_<PlugIn>_<SwcBswl>.h	

D.1.9 Rte_Rips_ReturnResult

Service Name	Rte_Rips_<PlugIn>_ReturnResult_<SwcBswI>_<CGI>(draft)	
Syntax	<pre>Std_ReturnType Rte_Rips_<PlugIn>_ReturnResult_<SwcBswI>_<CGI> ([IN/OUT OUT] <param_1>, [IN/OUT OUT] <param_n>, [Std_TransformerError transformerError])</pre>	
Service ID [hex]	0xED	
Sync/Async	Synchronous	
Reentrancy	Reentrant	
Parameters (in)	None	
Parameters (inout)	<param_1>	The Rte_Rips_ReturnResult API includes zero or more IN/OUT and OUT parameters according SWS_Rte_01111.
Parameters (out)	<param_n>	The Rte_Rips_ReturnResult API includes zero or more IN/OUT and OUT parameters according SWS_Rte_01111.
	transformerError	The OUT parameter transformerError contains the transformer error which occurred during execution of the transformer chain.
Return value	Std_ReturnType	The return value is used to indicate communication errors
Description	Rte_Rips_ReturnResult get the server results of a performed a transformer or cross cluster invocation for clients.	
Available via	Rte_Rips_<PlugIn>_<SwcBswI>.h	

D.1.10 Rte_Rips_Start

Service Name	Rte_Rips_<PlugIn>_Rte_Start	
Syntax	<pre>void Rte_Rips_<PlugIn>_Rte_Start (void)</pre>	
Service ID [hex]	0xF1	
Sync/Async	Synchronous	
Reentrancy	Non Reentrant	
Parameters (in)	None	
Parameters (inout)	None	
Parameters (out)	None	
Return value	None	
Description	Rte_Rips_Rte_Start initializes those RTE Implementation Plug-In parts which are relevant for the RTE related operation.	
Available via	Rte_Rips_<PlugIn>.h	

D.1.11 Rte_Rips_Stop

Service Name	Rte_Rips_<PlugIn>_Rte_Stop
Syntax	void Rte_Rips_<PlugIn>_Rte_Stop (void)
Service ID [hex]	0xF2
Sync/Async	Synchronous
Reentrancy	Non Reentrant
Parameters (in)	None
Parameters (inout)	None
Parameters (out)	None
Return value	None
Description	Rte_Rips_Rte_Stop deinitializes those RTE Implementation Plug-In parts which are relevant for the RTE related operation.
Available via	Rte_Rips_<PlugIn>.h

D.1.12 Rte_Rips_SchM_Deinit

Service Name	Rte_Rips_SchM_Deinit
Syntax	void Rte_Rips_SchM_Deinit (void)
Service ID [hex]	0xF3
Sync/Async	Synchronous
Reentrancy	Non Reentrant
Parameters (in)	None
Parameters (inout)	None
Parameters (out)	None
Return value	None
Description	Rte_Rips_SchM_Deinit deinitializes those RTE Implementation Plug-In parts which are relevant for the SchM related operations.
Available via	Rte_Rips_<PlugIn>.h

D.1.13 Rte_Rips_SchM_Init

Service Name	Rte_Rips_<PlugIn>_SchM_Init
Syntax	void Rte_Rips_<PlugIn>_SchM_Init (void)
Service ID [hex]	0xF0
Sync/Async	Synchronous
Reentrancy	Non Reentrant





Parameters (in)	None
Parameters (inout)	None
Parameters (out)	None
Return value	None
Description	Rte_Rips_SchM_Init initializes those RTE Implementation Plug-In parts which are relevant for the SchM related operations.
Available via	Rte_Rips_<PlugIn>.h

D.1.14 Rte_Rips_SwitchNotificationStatusType

Name	Rte_Rips_SwitchNotificationStatusType (draft)		
Kind	Type		
Derived from	uint8		
Range	RTE_SWITCH_NOTIFICATION_SKIP	0x00	mode switch notification cannot be dequeued
	RTE_SWITCH_NOTIFICATION_ENQUEUED_FIRST	0x01	mode switch notification is enqueued into an empty mode queue
	RTE_SWITCH_NOTIFICATION_ENQUEUED_NOT_FIRST	0x02	mode switch notification is enqueued into a non empty mode queue
	RTE_SWITCH_NOTIFICATION_ENQUEUE_FAILED	0x03	enqueue operation into a non empty mode queue failed
	RTE_SWITCH_NOTIFICATION_DEQUEUED_LAST	0x04	last mode switch notification was enqueued from mode queue
	RTE_SWITCH_NOTIFICATION_DEQUEUED_NOT_LAST	0x05	mode switch notification was enqueued from mode queue, further mode switch notifications are in the queue
Description	Status of the en- and dequeue operation on a mode queue Tags: atp.Status=draft		
Available via	Rte_Type.h		

D.1.15 Rte_Rips_Switch

Service Name	Rte_Rips_<PlugIn>_Switch_<BswSwcI>_<MMI> (draft)
Syntax	<pre>void Rte_Rips_<PlugIn>_Switch_<BswSwcI>_<MMI> (Rte_Rips_SwitchNotificationStatusType switchNotificationStatus, uint32 previousmode, uint32 nextmode)</pre>
Service ID [hex]	0xB0





Sync/Async	Synchronous	
Reentrancy	Reentrant	
Parameters (in)	switchNotificationStatus	Status of the enqueue operation
	previousmode	The value of the ModeDeclaration of the mode being left
	nextmode	The value of the ModeDeclaration of the mode being entered
Parameters (inout)	None	
Parameters (out)	None	
Return value	None	
Description	Rte_Rips_StartModeSwitch notifies the RTE Implementation Plug-In about an enqueue operation in a mode queue. Tags: atp.Status=draft	
Available via	Rte_Rips_<PlugIn>.h	

D.1.16 Rte_Rips_DequeueModeSwitch

Service Name	Rte_Rips_<PlugIn>_DequeueModeSwitch_<MMI>_<OsTask> (draft)	
Syntax	<pre>Rte_Rips_SwitchNotificationStatusType Rte_Rips_<PlugIn>_DequeueModeSwitch_<MMI>_<OsTask> (void)</pre>	
Service ID [hex]	0xB1	
Sync/Async	Synchronous	
Reentrancy	Reentrant	
Parameters (in)	None	
Parameters (inout)	None	
Parameters (out)	None	
Return value	Rte_Rips_SwitchNotificationStatusType	The return value is used indicate the status of the dequeue operation in a mode queue
Description	Rte_Rips_DequeueModeSwitch dequeues a mode switch notification from the mode queue when it is called after the last on-entry ExecutableEntity terminated. Tags: atp.Status=draft	
Available via	Rte_Buffers.h	

D.1.17 Rte_Rips_Trigger

Service Name	Rte_Rips_<PlugIn>_Trigger_<BswSwcI>_<MMI> (draft)	
Syntax	<pre>void Rte_Rips_<PlugIn>_Trigger_<BswSwcI>_<MMI> (void)</pre>	
Service ID [hex]	0xB2	
Sync/Async	Synchronous	
Reentrancy	Reentrant	





Parameters (in)	None
Parameters (inout)	None
Parameters (out)	None
Return value	None
Description	Rte_Rips_Trigger notifies the RTE Implementation Plug-In about a raised trigger. Tags: atp.Status=draft
Available via	Rte_Rips_<PlugIn>.h

D.1.18 Rte_Rips_Write

Service Name	Rte_Rips_<PlugIn>_Write_<SwcBswl>[[Partition][_<ExE>]_<CGI>](draft)	
Syntax	<pre>Std_ReturnType Rte_Rips_<PlugIn>_Write_<SwcBswl> [[Partition] [_<ExE>]_<CGI> (IN <data>, [Std_TransformerError transformerError])</pre>	
Service ID [hex]	0xEB	
Sync/Async	Synchronous	
Reentrancy	Reentrant	
Parameters (in)	<data>	The IN parameter <data> pass the received data.
Parameters (inout)	None	
Parameters (out)	transformerError	The OUT parameter transformerError contains the transformer error which occurred during execution of the transformer chain.
Return value	Std_ReturnType	The return value is used to indicate communication errors.
Description	Rte_Rips_Write Performs an "explicit" write on a sender-receiver communication data element.	
Available via	Rte_Rips_<PlugIn>_<SwcBswl>.h	

D.2 OS

See document [5] and [23] as reference for Os.

- TASK
- ActivateTask
- ChainTask
- TerminateTask
- GetResource
- ReleaseResource
- SuspendOSInterrupts

- ResumeOSInterrupts
- GetSpinlock
- ReleaseSpinlock
- GetApplicationID
- StartScheduleTable
- StopScheduleTable
- Schedule
- DisableAllInterrupts
- EnableAllInterrupts
- SuspendAllInterrupts
- ResumeAllInterrupts
- GetResource
- ReleaseResource
- SuspendOSInterrupts
- ResumeOSInterrupts
- ReleaseResource
- GetSpinlock
- ReleaseSpinlock
- GetApplicationID
- CallTrustedFunction
- GetCoreID

D.3 NvM

D.3.1 NvM_CancelJobs

Service Name	NvM_CancelJobs
Syntax	Std_ReturnType NvM_CancelJobs (NvM_BlockIdType BlockId)
Service ID [hex]	0x10
Sync/Async	Synchronous





Reentrancy	Reentrant	
Parameters (in)	BlockId	The block identifier uniquely identifies one NVRAM block descriptor. A NVRAM block descriptor contains all needed information about a single NVRAM block.
Parameters (inout)	None	
Parameters (out)	None	
Return value	Std_ReturnType	E_OK: The job was successfully removed from queue. E_NOT_OK: The job could not be found in the queue.
Description	Service to cancel all jobs pending for a NV block.	
Available via	NvM.h	

D.3.2 NvM_EraseNvBlock

Service Name	NvM_EraseNvBlock	
Syntax	Std_ReturnType NvM_EraseNvBlock (NvM_BlockIdType BlockId)	
Service ID [hex]	0x09	
Sync/Async	Asynchronous	
Reentrancy	Reentrant	
Parameters (in)	BlockId	The block identifier uniquely identifies one NVRAM block descriptor. A NVRAM block descriptor contains all needed information about a single NVRAM block.
Parameters (inout)	None	
Parameters (out)	None	
Return value	Std_ReturnType	E_OK: request has been accepted E_NOT_OK: request has not been accepted
Description	Service to erase a NV block.	
Available via	NvM.h	

D.3.3 NvM_GetDataIndex

Service Name	NvM_GetDataIndex	
Syntax	Std_ReturnType NvM_GetDataIndex (NvM_BlockIdType BlockId, uint8* DataIndexPtr)	
Service ID [hex]	0x02	
Sync/Async	Synchronous	
Reentrancy	Reentrant	
Parameters (in)	BlockId	The block identifier uniquely identifies one NVRAM block descriptor. A NVRAM block descriptor contains all needed information about a single NVRAM block.
Parameters (inout)	None	





Parameters (out)	DataIndexPtr	Pointer to where to store the current dataset index (0..255)
Return value	Std_ReturnType	E_OK: The index position has been retrieved successfully. E_NOT_OK: An error occurred.
Description	Service for getting the currently set DataIndex of a dataset NVRAM block	
Available via	NvM.h	

D.3.4 NvM_GetErrorStatus

Service Name	NvM_GetErrorStatus	
Syntax	<pre>Std_ReturnType NvM_GetErrorStatus (NvM_BlockIdType BlockId, NvM_RequestResultType* RequestResultPtr)</pre>	
Service ID [hex]	0x04	
Sync/Async	Synchronous	
Reentrancy	Reentrant	
Parameters (in)	BlockId	The block identifier uniquely identifies one NVRAM block descriptor. A NVRAM block descriptor contains all needed information about a single NVRAM block.
Parameters (inout)	None	
Parameters (out)	RequestResultPtr	Pointer to where to store the request result. See NvM_RequestResultType .
Return value	Std_ReturnType	E_OK: The block dependent error/status information was read successfully. E_NOT_OK: An error occurred.
Description	Service to read the block dependent error/status information.	
Available via	NvM.h	

D.3.5 NvM_InvalidateNvBlock

Service Name	NvM_InvalidateNvBlock	
Syntax	<pre>Std_ReturnType NvM_InvalidateNvBlock (NvM_BlockIdType BlockId)</pre>	
Service ID [hex]	0x0b	
Sync/Async	Asynchronous	
Reentrancy	Reentrant	
Parameters (in)	BlockId	The block identifier uniquely identifies one NVRAM block descriptor. A NVRAM block descriptor contains all needed information about a single NVRAM block.
Parameters (inout)	None	
Parameters (out)	None	
Return value	Std_ReturnType	E_OK: request has been accepted E_NOT_OK: request has not been accepted





Description	Service to invalidate a NV block.
Available via	NvM.h

D.3.6 NvM_ReadBlock

Service Name	NvM_ReadBlock	
Syntax	<pre>Std_ReturnType NvM_ReadBlock (NvM_BlockIdType BlockId, void* NvM_DstPtr)</pre>	
Service ID [hex]	0x06	
Sync/Async	Asynchronous	
Reentrancy	Reentrant	
Parameters (in)	BlockId	The block identifier uniquely identifies one NVRAM block descriptor. A NVRAM block descriptor contains all needed information about a single NVRAM block.
Parameters (inout)	None	
Parameters (out)	NvM_DstPtr	Pointer to the RAM data block.
Return value	Std_ReturnType	E_OK: request has been accepted E_NOT_OK: request has not been accepted
Description	Service to copy the data of the NV block to its corresponding RAM block.	
Available via	NvM.h	

D.3.7 NvM_ReadPRAMBlock

Service Name	NvM_ReadPRAMBlock	
Syntax	<pre>Std_ReturnType NvM_ReadPRAMBlock (NvM_BlockIdType BlockId)</pre>	
Service ID [hex]	0x16	
Sync/Async	Asynchronous	
Reentrancy	Reentrant	
Parameters (in)	BlockId	The block identifier uniquely identifies one NVRAM block descriptor. A NVRAM block descriptor contains all needed information about a single NVRAM block.
Parameters (inout)	None	
Parameters (out)	None	
Return value	Std_ReturnType	E_OK: request has been accepted E_NOT_OK: request has not been accepted
Description	Service to copy the data of the NV block to its corresponding permanent RAM block.	
Available via	NvM.h	

D.3.8 NvM_RestoreBlockDefaults

Service Name	NvM_RestoreBlockDefaults	
Syntax	<pre>Std_ReturnType NvM_RestoreBlockDefaults (NvM_BlockIdType BlockId, void* NvM_DestPtr)</pre>	
Service ID [hex]	0x08	
Sync/Async	Asynchronous	
Reentrancy	Non Reentrant	
Parameters (in)	BlockId	The block identifier uniquely identifies one NVRAM block descriptor. A NVRAM block descriptor contains all needed information about a single NVRAM block.
Parameters (inout)	None	
Parameters (out)	NvM_DestPtr	Pointer to the RAM data block.
Return value	Std_ReturnType	E_OK: request has been accepted E_NOT_OK: request has not been accepted
Description	Service to restore the default data to its corresponding RAM block.	
Available via	NvM.h	

D.3.9 NvM_RestorePRAMBlockDefaults

Service Name	NvM_RestorePRAMBlockDefaults	
Syntax	<pre>Std_ReturnType NvM_RestorePRAMBlockDefaults (NvM_BlockIdType BlockId)</pre>	
Service ID [hex]	0x18	
Sync/Async	Asynchronous	
Reentrancy	Non Reentrant	
Parameters (in)	BlockId	The block identifier uniquely identifies one NVRAM block descriptor. A NVRAM block descriptor contains all needed information about a single NVRAM block.
Parameters (inout)	None	
Parameters (out)	None	
Return value	Std_ReturnType	E_OK: request has been accepted E_NOT_OK: request has not been accepted
Description	Service to restore the default data to its corresponding permanent RAM block.	
Available via	NvM.h	

D.3.10 NvM_SetBlockLockStatus

Service Name	NvM_SetBlockLockStatus	
Syntax	<pre>void NvM_SetBlockLockStatus (NvM_BlockIdType BlockId, boolean BlockLocked)</pre>	
Service ID [hex]	0x13	
Sync/Async	Synchronous	
Reentrancy	Reentrant	
Parameters (in)	BlockId	The block identifier uniquely identifies one NVRAM block descriptor. A NVRAM block descriptor contains all needed information about a single NVRAM block.
	BlockLocked	TRUE: Mark the RAM.block as locked FALSE: Mark the RAM.block as unlocked
Parameters (inout)	None	
Parameters (out)	None	
Return value	None	
Description	Service for setting the lock status of a permanent RAM block or of the explicit synchronization of a NVRAM block.	
Available via	NvM.h	

D.3.11 NvM_SetBlockProtection

Service Name	NvM_SetBlockProtection	
Syntax	<pre>Std_ReturnType NvM_SetBlockProtection (NvM_BlockIdType BlockId, boolean ProtectionEnabled)</pre>	
Service ID [hex]	0x03	
Sync/Async	Synchronous	
Reentrancy	Reentrant	
Parameters (in)	BlockId	The block identifier uniquely identifies one NVRAM block descriptor. A NVRAM block descriptor contains all needed information about a single NVRAM block.
	ProtectionEnabled	TRUE: Write protection shall be enabled FALSE: Write protection shall be disabled
Parameters (inout)	None	
Parameters (out)	None	
Return value	Std_ReturnType	E_OK: The block was enabled/disabled as requested E_NOT_OK: An error occurred.
Description	Service for setting/resetting the write protection for a NV block.	
Available via	NvM.h	

D.3.12 NvM_SetDataIndex

Service Name	NvM_SetDataIndex	
Syntax	<pre>Std_ReturnType NvM_SetDataIndex (NvM_BlockIdType BlockId, uint8 DataIndex)</pre>	
Service ID [hex]	0x01	
Sync/Async	Synchronous	
Reentrancy	Reentrant	
Parameters (in)	BlockId	The block identifier uniquely identifies one NVRAM block descriptor. A NVRAM block descriptor contains all needed information about a single NVRAM block.
	DataIndex	Index position (association) of a NV/ROM block.
Parameters (inout)	None	
Parameters (out)	None	
Return value	Std_ReturnType	E_OK: The index position was set successfully. E_NOT_OK: An error occurred.
Description	Service for setting the DataIndex of a dataset NVRAM block.	
Available via	NvM.h	

D.3.13 NvM_SetRamBlockStatus

Service Name	NvM_SetRamBlockStatus	
Syntax	<pre>Std_ReturnType NvM_SetRamBlockStatus (NvM_BlockIdType BlockId, boolean BlockChanged)</pre>	
Service ID [hex]	0x05	
Sync/Async	Synchronous	
Reentrancy	Reentrant	
Parameters (in)	BlockId	The block identifier uniquely identifies one NVRAM block descriptor. A NVRAM block descriptor contains all needed information about a single NVRAM block.
	BlockChanged	TRUE: Validate the permanent RAM block or the explicit synchronization and mark block as changed. FALSE: Invalidate the permanent RAM block or the explicit synchronization and mark block as unchanged.
Parameters (inout)	None	
Parameters (out)	None	
Return value	Std_ReturnType	E_OK: The status of the permanent RAM block or the explicit synchronization was changed as requested. E_NOT_OK: An error occurred.
Description	Service for setting the RAM block status of a permanent RAM block or the status of the explicit synchronization of a NVRAM block.	
Available via	NvM.h	

D.3.14 NvM_WriteBlock

Service Name	NvM_WriteBlock	
Syntax	<pre>Std_ReturnType NvM_WriteBlock (NvM_BlockIdType BlockId, const void* NvM_SrcPtr)</pre>	
Service ID [hex]	0x07	
Sync/Async	Asynchronous	
Reentrancy	Reentrant	
Parameters (in)	BlockId	The block identifier uniquely identifies one NVRAM block descriptor. A NVRAM block descriptor contains all needed information about a single NVRAM block.
	NvM_SrcPtr	Pointer to the RAM data block.
Parameters (inout)	None	
Parameters (out)	None	
Return value	Std_ReturnType	E_OK: request has been accepted E_NOT_OK: request has not been accepted
Description	Service to copy the data of the RAM block to its corresponding NV block.	
Available via	NvM.h	

D.3.15 NvM_WritePRAMBlock

Service Name	NvM_WritePRAMBlock	
Syntax	<pre>Std_ReturnType NvM_WritePRAMBlock (NvM_BlockIdType BlockId)</pre>	
Service ID [hex]	0x17	
Sync/Async	Asynchronous	
Reentrancy	Reentrant	
Parameters (in)	BlockId	The block identifier uniquely identifies one NVRAM block descriptor. A NVRAM block descriptor contains all needed information about a single NVRAM block.
Parameters (inout)	None	
Parameters (out)	None	
Return value	Std_ReturnType	E_OK: request has been accepted E_NOT_OK: request has not been accepted
Description	Service to copy the data of the permanent RAM block to its corresponding NV block.	
Available via	NvM.h	

D.3.16 NvM_SingleBlockCallbackFunction

Service Name	NvM_SingleBlockCallbackFunction	
Syntax	<pre>Std_ReturnType NvM_SingleBlockCallbackFunction (NvM_BlockRequestType BlockRequest, NvM_RequestResultType JobResult)</pre>	
Sync/Async	Synchronous	
Reentrancy	Non Reentrant	
Parameters (in)	BlockRequest	The request type (read, write, ... etc.) of the previous processed block job
	JobResult	The request result of the previous processed block job.
Parameters (inout)	None	
Parameters (out)	None	
Return value	Std_ReturnType	E_OK: callback function has been processed successfully any other: callback function has been processed unsuccessfully
Description	Per block callback routine to notify the upper layer that an asynchronous single block request has been finished.	
Available via	NvM_Externals.h	

D.3.17 NvM_InitBlockCallbackFunction

Service Name	NvM_InitBlockCallbackFunction	
Syntax	<pre>Std_ReturnType NvM_InitBlockCallbackFunction (NvM_InitBlockRequestType InitBlockRequest)</pre>	
Sync/Async	Synchronous	
Reentrancy	Non Reentrant	
Parameters (in)	InitBlockRequest	The request type (read, restore, ... etc.) of the currently processed block
Parameters (inout)	None	
Parameters (out)	None	
Return value	Std_ReturnType	E_OK: callback function has been processed successfully any other: callback function has been processed unsuccessfully
Description	Per block callback routine which shall be called by the NvM module when default data needs to be restored in RAM, and a ROM block is not configured.	
Available via	NvM_Externals.h	

D.3.18 NvM_ReadRamBlockFromNvm

Service Name	NvM_ReadRamBlockFromNvm	
Syntax	<pre>Std_ReturnType NvM_ReadRamBlockFromNvm (const void* NvMBuffer)</pre>	





Sync/Async	Synchronous	
Reentrancy	Non Reentrant	
Parameters (in)	NvMBuffer	the address of the buffer where the data can be read from
Parameters (inout)	None	
Parameters (out)	None	
Return value	Std_ReturnType	E_OK: callback function has been processed successfully any other: callback function has been processed unsuccessfully
Description	Block specific callback routine which shall be called in order to let the application copy data from NvM module's mirror to RAM block.	
Available via	NvM_Externals.h	

D.3.19 NvM_WriteRamBlockToNvm

Service Name	NvM_WriteRamBlockToNvm	
Syntax	Std_ReturnType NvM_WriteRamBlockToNvm (void* NvMBuffer)	
Sync/Async	Synchronous	
Reentrancy	Non Reentrant	
Parameters (in)	None	
Parameters (inout)	None	
Parameters (out)	NvMBuffer	the address of the buffer where the data shall be written to
Return value	Std_ReturnType	E_OK: callback function has been processed successfully any other: callback function has been processed unsuccessfully
Description	Block specific callback routine which shall be called in order to let the application copy data from RAM block to NvM module's mirror.	
Available via	NvM_Externals.h	

D.4 Com

D.4.1 Com_SendSignal

Service Name	Com_SendSignal	
Syntax	uint8 Com_SendSignal (Com_SignalIdType SignalId, const void* SignalDataPtr)	
Service ID [hex]	0x0a	
Sync/Async	Asynchronous	
Reentrancy	Reentrant	
Parameters (in)	SignalId	Id of signal to be sent.
	SignalDataPtr	Reference to the signal data to be transmitted.





Parameters (inout)	None	
Parameters (out)	None	
Return value	uint8	E_OK: service has been accepted COM_SERVICE_NOT_AVAILABLE: corresponding I-PDU group was stopped COM_BUSY: in case the TP-Buffer is locked for large data types handling
Description	The service Com_SendSignal updates the signal object identified by SignalId with the signal referenced by the SignalDataPtr parameter.	
Available via	Com.h	

D.4.2 Com_SendDynSignal

Service Name	Com_SendDynSignal	
Syntax	<pre>uint8 Com_SendDynSignal (Com_SignalIdType SignalId, const void* SignalDataPtr, uint16 Length)</pre>	
Service ID [hex]	0x21	
Sync/Async	Asynchronous	
Reentrancy	Reentrant	
Parameters (in)	SignalId	Id of signal to be sent.
	SignalDataPtr	Reference to the signal data to be transmitted.
	Length	Length of the dynamic length signal
Parameters (inout)	None	
Parameters (out)	None	
Return value	uint8	E_OK: service has been accepted E_NOT_OK: in case the Length is greater than the configured ComSignalLength of this sent signal COM_SERVICE_NOT_AVAILABLE: corresponding I-PDU group was stopped COM_BUSY: in case the TP-Buffer is locked
Description	The service Com_SendDynSignal updates the signal object identified by SignalId with the signal referenced by the SignalDataPtr parameter.	
Available via	Com.h	

D.4.3 Com_SendSignalGroup

Service Name	Com_SendSignalGroup	
Syntax	<pre>uint8 Com_SendSignalGroup (Com_SignalGroupIdType SignalGroupId)</pre>	
Service ID [hex]	0x0d	
Sync/Async	Asynchronous	





Reentrancy	Reentrant	
Parameters (in)	SignalGroupId	Id of signal group to be sent.
Parameters (inout)	None	
Parameters (out)	None	
Return value	uint8	E_OK: service has been accepted COM_SERVICE_NOT_AVAILABLE: corresponding I-PDU group was stopped COM_BUSY: in case the TP-Buffer is locked for large data types handling
Description	The service Com_SendSignalGroup copies the content of the associated shadow buffer to the associated I-PDU.	
Available via	Com.h	

D.4.4 Com_SendSignalGroupArray

Service Name	Com_SendSignalGroupArray	
Syntax	<pre>uint8 Com_SendSignalGroupArray (Com_SignalGroupIdType SignalGroupId, const uint8* SignalGroupArrayPtr)</pre>	
Service ID [hex]	0x23	
Sync/Async	Asynchronous	
Reentrancy	Reentrant	
Parameters (in)	SignalGroupId	Id of signal group to be sent.
	SignalGroupArrayPtr	Reference to the signal group array.
Parameters (inout)	None	
Parameters (out)	None	
Return value	uint8	E_OK: service has been accepted COM_SERVICE_NOT_AVAILABLE: corresponding I-PDU group was stopped COM_BUSY: in case the TP-Buffer is locked for large data types handling
Description	The service Com_SendSignalGroupArray copies the content of the provided SignalGroupArray Ptr to the associated I-PDU. The provided data shall correspond to the array representation of the signal group.	
Available via	Com.h	

D.4.5 Com_SendSignalWithMetaData

Service Name	Com_SendSignalWithMetaData	
Syntax	<pre>uint8 Com_SendSignalWithMetaData (Com_SignalIdType SignalId, const void* SignalDataPtr, const uint8* MetaDataPtr)</pre>	





Service ID [hex]	0x4d	
Sync/Async	Asynchronous	
Reentrancy	Reentrant	
Parameters (in)	SignalId	Id of signal to be sent.
	SignalDataPtr	Reference to the signal data to be transmitted.
	MetaDataPtr	Pointer to the meta data of the signal
Parameters (inout)	None	
Parameters (out)	None	
Return value	uint8	E_OK: service has been accepted COM_SERVICE_NOT_AVAILABLE: corresponding I-PDU group was stopped COM_BUSY: in case the TP-Buffer is locked for large data types handling
Description	The service Com_SendSignalWithMetaData updates the signal object identified by SignalId with the signal referenced by the SignalDataPtr parameter. The meta data is provided via the MetaDataPtr parameter.	
Available via	Com.h	

D.4.6 Com_SendDynSignalWithMetaData

Service Name	Com_SendDynSignalWithMetaData	
Syntax	<pre>uint8 Com_SendDynSignalWithMetaData (Com_SignalIdType SignalId, const void* SignalDataPtr, uint16 Length, const uint8* MetaDataPtr)</pre>	
Service ID [hex]	0x4e	
Sync/Async	Asynchronous	
Reentrancy	Reentrant	
Parameters (in)	SignalId	Id of signal to be sent.
	SignalDataPtr	Reference to the signal data to be transmitted.
	Length	Length of the dynamic length signal
	MetaDataPtr	Pointer to the meta data of the signal
Parameters (inout)	None	
Parameters (out)	None	
Return value	uint8	E_OK: service has been accepted E_NOT_OK: in case the Length is greater than the configured ComSignalLength of this sent signal COM_SERVICE_NOT_AVAILABLE: corresponding I-PDU group was stopped COM_BUSY: in case the TP-Buffer is locked
Description	The service Com_SendDynSignalWithMetaData updates the signal object identified by SignalId with the signal referenced by the SignalDataPtr parameter. The meta data is provided via the MetaDataPtr parameter.	
Available via	Com.h	

D.4.7 Com_SendSignalGroupWithMetaData

Service Name	Com_SendSignalGroupWithMetaData	
Syntax	<pre>uint8 Com_SendSignalGroupWithMetaData (Com_SignalGroupIdType SignalGroupId, const uint8* MetaDataPtr)</pre>	
Service ID [hex]	0x4f	
Sync/Async	Asynchronous	
Reentrancy	Reentrant	
Parameters (in)	SignalGroupId	Id of signal group to be sent.
	MetaDataPtr	Pointer to the meta data of the signal group
Parameters (inout)	None	
Parameters (out)	None	
Return value	uint8	E_OK: service has been accepted COM_SERVICE_NOT_AVAILABLE: corresponding I-PDU group was stopped COM_BUSY: in case the TP-Buffer is locked for large data types handling
Description	The service Com_SendSignalGroupWithMetaData copies the content of the associated shadow buffer to the associated I-PDU. The meta data is provided via the MetaDataPtr parameter.	
Available via	Com.h	

D.4.8 Com_SendSignalGroupArrayWithMetaData

Service Name	Com_SendSignalGroupArrayWithMetaData	
Syntax	<pre>uint8 Com_SendSignalGroupArrayWithMetaData (Com_SignalGroupIdType SignalGroupId, const uint8* SignalGroupArrayPtr, const uint8* MetaDataPtr)</pre>	
Service ID [hex]	0x50	
Sync/Async	Asynchronous	
Reentrancy	Reentrant	
Parameters (in)	SignalGroupId	Id of signal group to be sent.
	SignalGroupArrayPtr	Reference to the signal group array.
	MetaDataPtr	Pointer to the meta data of the signal group.
Parameters (inout)	None	
Parameters (out)	None	
Return value	uint8	E_OK: service has been accepted COM_SERVICE_NOT_AVAILABLE: corresponding I-PDU group was stopped COM_BUSY: in case the TP-Buffer is locked for large data types handling
Description	The service Com_SendSignalGroupArrayWithMetaData copies the content of the provided SignalGroupArrayPtr to the associated I-PDU. The provided data shall correspond to the array representation of the signal group. The meta data is provided via the MetaDataPtr parameter.	
Available via	Com.h	

D.4.9 Com_ReceiveSignal

Service Name	Com_ReceiveSignal	
Syntax	<pre>uint8 Com_ReceiveSignal (Com_SignalIdType SignalId, void* SignalDataPtr)</pre>	
Service ID [hex]	0x0b	
Sync/Async	Synchronous	
Reentrancy	Reentrant	
Parameters (in)	SignalId	Id of signal to be received.
Parameters (inout)	None	
Parameters (out)	SignalDataPtr	Reference to the location where the received signal data shall be stored
Return value	uint8	E_OK: service has been accepted COM_SERVICE_NOT_AVAILABLE: corresponding I-PDU group was stopped COM_BUSY: in case the TP-Buffer is locked for large data types handling
Description	Com_ReceiveSignal copies the data of the signal identified by SignalId to the location specified by SignalDataPtr.	
Available via	Com.h	

D.4.10 Com_ReceiveDynSignal

Service Name	Com_ReceiveDynSignal	
Syntax	<pre>uint8 Com_ReceiveDynSignal (Com_SignalIdType SignalId, void* SignalDataPtr, uint16* Length)</pre>	
Service ID [hex]	0x22	
Sync/Async	Synchronous	
Reentrancy	Reentrant	
Parameters (in)	SignalId	Id of signal to be received.
Parameters (inout)	Length	in: maximum length that could be received out: length of the dynamic length signal
Parameters (out)	SignalDataPtr	reference to the location where the received signal data shall be stored
Return value	uint8	E_OK: service has been accepted E_NOT_OK: in case the Length (as in-parameter) is smaller than the received length of the dynamic length signal COM_SERVICE_NOT_AVAILABLE: corresponding I-PDU group was stopped COM_BUSY: in case the TP-Buffer is locked
Description	Com_ReceiveDynSignal copies the data of the signal identified by SignalId to the location specified by SignalDataPtr and stores the length of the dynamical length signal at the position given by the Length parameter.	
Available via	Com.h	

D.4.11 Com_ReceiveSignalGroup

Service Name	Com_ReceiveSignalGroup	
Syntax	<pre>uint8 Com_ReceiveSignalGroup (Com_SignalGroupIdType SignalGroupId)</pre>	
Service ID [hex]	0x0e	
Sync/Async	Synchronous	
Reentrancy	Reentrant	
Parameters (in)	SignalGroupId	Id of signal group to be received.
Parameters (inout)	None	
Parameters (out)	None	
Return value	uint8	E_OK: service has been accepted COM_SERVICE_NOT_AVAILABLE: corresponding I-PDU group was stopped COM_BUSY: in case the TP-Buffer is locked for large data types handling
Description	The service Com_ReceiveSignalGroup copies the received signal group from the I-PDU to the shadow buffer.	
Available via	Com.h	

D.4.12 Com_ReceiveSignalGroupArray

Service Name	Com_ReceiveSignalGroupArray	
Syntax	<pre>uint8 Com_ReceiveSignalGroupArray (Com_SignalGroupIdType SignalGroupId, uint8* SignalGroupArrayPtr)</pre>	
Service ID [hex]	0x24	
Sync/Async	Synchronous	
Reentrancy	Reentrant	
Parameters (in)	SignalGroupId	Id of signal group to be received.
Parameters (inout)	None	
Parameters (out)	SignalGroupArrayPtr	reference to the location where the received signal group array shall be stored
Return value	uint8	E_OK: service has been accepted COM_SERVICE_NOT_AVAILABLE: corresponding I-PDU group was stopped COM_BUSY: in case the TP-Buffer is locked for large data types handling
Description	The service Com_ReceiveSignalGroupArray copies the received signal group array representation from the PDU to the location designated by SignalGroupArrayPtr.	
Available via	Com.h	

D.4.13 Com_ReceiveSignalWithMetaData

Service Name	Com_ReceiveSignalWithMetaData	
Syntax	<pre>uint8 Com_ReceiveSignalWithMetaData (Com_SignalIdType SignalId, void* SignalDataPtr, uint8* MetaDataPtr)</pre>	
Service ID [hex]	0x49	
Sync/Async	Synchronous	
Reentrancy	Reentrant	
Parameters (in)	SignalId	Id of signal to be received.
Parameters (inout)	None	
Parameters (out)	SignalDataPtr	Reference to the location where the received signal data shall be stored
	MetaDataPtr	Pointer to the meta data of the signal
Return value	uint8	–
Description	Com_ReceiveSignalWithMetaData copies the data of the signal identified by SignalId to the location specified by SignalDataPtr. The received meta data is stored at the position given by the MetaDataPtr parameter.	
Available via	Com.h	

D.4.14 Com_ReceiveDynSignalWithMetaData

Service Name	Com_ReceiveDynSignalWithMetaData	
Syntax	<pre>uint8 Com_ReceiveDynSignalWithMetaData (Com_SignalIdType SignalId, void* SignalDataPtr, uint16* Length, uint8* MetaDataPtr)</pre>	
Service ID [hex]	0x4a	
Sync/Async	Synchronous	
Reentrancy	Reentrant	
Parameters (in)	SignalId	Id of signal to be received.
Parameters (inout)	None	
Parameters (out)	SignalDataPtr	reference to the location where the received signal data shall be stored
	Length	–
	MetaDataPtr	Pointer to the meta data of the signal
Return value	uint8	E_OK: service has been accepted E_NOT_OK: in case the Length (as in-parameter) is smaller than the received length of the dynamic length signal COM_SERVICE_NOT_AVAILABLE: corresponding I-PDU group was stopped COM_BUSY: in case the TP-Buffer is locked
Description	Com_ReceiveDynSignalWithMetaData copies the data of the signal identified by SignalId to the location specified by SignalDataPtr and stores the length of the dynamical length signal at the position given by the Length parameter. The received meta data is stored at the position given by the MetaDataPtr parameter.	
Available via	Com.h	

D.4.15 Com_ReceiveSignalGroupWithMetaData

Service Name	Com_ReceiveSignalGroupWithMetaData	
Syntax	<pre>uint8 Com_ReceiveSignalGroupWithMetaData (Com_SignalGroupIdType SignalGroupId, uint8* MetaDataPtr)</pre>	
Service ID [hex]	0x4b	
Sync/Async	Synchronous	
Reentrancy	Reentrant	
Parameters (in)	SignalGroupId	Id of signal group to be received.
Parameters (inout)	None	
Parameters (out)	MetaDataPtr	Pointer to the meta data of the signal group
Return value	uint8	E_OK: service has been accepted COM_SERVICE_NOT_AVAILABLE: corresponding I-PDU group was stopped COM_BUSY: in case the TP-Buffer is locked for large data types handling
Description	The service Com_ReceiveSignalGroupWithMetaData copies the received signal group from the I-PDU to the shadow buffer. The received meta data is stored at the position given by the MetaDataPtr parameter.	
Available via	Com.h	

D.4.16 Com_ReceiveSignalGroupArrayWithMetaData

Service Name	Com_ReceiveSignalGroupArrayWithMetaData	
Syntax	<pre>void Com_ReceiveSignalGroupArrayWithMetaData (Com_SignalGroupIdType SignalGroupId, uint8* SignalGroupArrayPtr, uint8* MetaDataPtr)</pre>	
Service ID [hex]	0x4c	
Sync/Async	Synchronous	
Reentrancy	Reentrant	
Parameters (in)	SignalGroupId	Id of signal group to be received.
Parameters (inout)	None	
Parameters (out)	SignalGroupArrayPtr	reference to the location where the received signal group array shall be stored
	MetaDataPtr	Pointer to the meta data of the signal group.
Return value	None	
Description	The service Com_ReceiveSignalGroupArrayWithMetaData copies the received signal group array representation from the PDU to the location designated by SignalGroupArrayPtr. The received meta data is stored at the position given by the MetaDataPtr parameter.	
Available via	Com.h	

D.4.17 Com_InvalidateSignal

Service Name	Com_InvalidateSignal	
Syntax	<pre>uint8 Com_InvalidateSignal (Com_SignalIdType SignalId)</pre>	
Service ID [hex]	0x10	
Sync/Async	Asynchronous	
Reentrancy	Reentrant	
Parameters (in)	SignalId	Id of signal to be invalidated.
Parameters (inout)	None	
Parameters (out)	None	
Return value	uint8	E_OK: service has been accepted COM_SERVICE_NOT_AVAILABLE: corresponding I-PDU group is stopped, no ComSignalDataInvalidValue is configured for the given signalId COM_BUSY: in case the TP-Buffer is locked
Description	The service Com_InvalidateSignal invalidates the signal with the given SignalId by setting its value to its configured ComSignalDataInvalidValue.	
Available via	Com.h	

D.4.18 Com_InvalidateSignalGroup

Service Name	Com_InvalidateSignalGroup	
Syntax	<pre>uint8 Com_InvalidateSignalGroup (Com_SignalGroupIdType SignalGroupId)</pre>	
Service ID [hex]	0x1b	
Sync/Async	Asynchronous	
Reentrancy	Reentrant	
Parameters (in)	SignalGroupId	Id of signal group to be invalidated.
Parameters (inout)	None	
Parameters (out)	None	
Return value	uint8	E_OK: service has been accepted COM_SERVICE_NOT_AVAILABLE: corresponding I-PDU group is stopped, no ComSignalDataInvalidValue is configured for any of the group signals COM_BUSY: in case the TP-Buffer is locked
Description	The service Com_InvalidateSignalGroup invalidates all group signals of the signal group with the given SignalGroupId by setting their values to their configured ComSignalDataInvalidValues.	
Available via	Com.h	

D.5 LdCom

D.5.1 LdCom_Transmit

Service Name	LdCom_Transmit	
Syntax	<pre>Std_ReturnType LdCom_Transmit (PduIdType Id, const PduInfoType* InfoPtr)</pre>	
Service ID [hex]	0x49	
Sync/Async	Synchronous	
Reentrancy	Reentrant for different Ids. Non reentrant for the same Id.	
Parameters (in)	Id	Identifier of the signal to be transmitted.
	InfoPtr	Length of and pointer to the signal data and pointer to MetaData.
Parameters (inout)	None	
Parameters (out)	None	
Return value	Std_ReturnType	E_OK: Transmit request has been accepted. E_NOT_OK: Transmit request has not been accepted.
Description	Requests transmission of a signal.	
Available via	LdCom.h	

D.6 Dcm

D.6.1 DataServices

D.6.1.1 ReadData

If `DcmDspDataUsePort` is set to `USE_DATA_SYNCH_FNC_PROXY`, the following definition is used:

Service Name	Xxx_ReadData (draft)	
Syntax	<pre>Std_ReturnType Xxx_ReadData (uint8* Data, uint16 DataLength, Dcm_NegativeResponseType* ErrorCode)</pre>	
Service ID [hex]	0x68	
Sync/Async	Synchronous	
Reentrancy	Non Reentrant	
Parameters (in)	DataLength	Length in byte of the data to be read
Parameters (inout)	None	
Parameters (out)	Data	Buffer where the requested data shall be copied to
	ErrorCode	If the operation <code>Xxx_ReadData</code> returns value <code>E_NOT_OK</code> , the <code>Dcm</code> module shall send a negative response with NRC code equal to the parameter <code>ErrorCode</code> parameter value.





Return value	Std_ReturnType	E_OK: Request was successful. E_NOT_OK: Request was not successful.
Description	This function requests to the application a data value of a DID/PID if DcmDspDataUsePort is set to USE_DATA_SYNCH_FNC_PROXY. Tags: atp.Status=draft	
Available via	Dcm_Externals.h	

If `DcmDspDataUsePort` is set to `USE_DATA_ASYNC_FNC_PROXY`, the following definition is used:

Service Name	Xxx_ReadData (draft)	
Syntax	<pre>Std_ReturnType Xxx_ReadData (Dcm_OpStatusType OpStatus, uint8* Data, uint16 DataLength, Dcm_NegativeResponseCodeType* ErrorCode)</pre>	
Service ID [hex]	0x69	
Sync/Async	Synchronous	
Reentrancy	Non Reentrant	
Parameters (in)	OpStatus	Status of the current operation
	DataLength	Length in byte of the data to be read
Parameters (inout)	None	
Parameters (out)	Data	Buffer where the requested data shall be copied to
	ErrorCode	If the operation <code>Xxx_ReadData</code> returns value <code>E_NOT_OK</code> , the <code>Dcm</code> module shall send a negative response with NRC code equal to the parameter <code>ErrorCode</code> parameter value.
Return value	Std_ReturnType	E_OK: Request was successful. E_NOT_OK: Request was not successful.
Description	This function requests to the application a data value of a DID/PID if <code>DcmDspDataUsePort</code> is set to <code>USE_DATA_ASYNC_FNC_PROXY</code> . Tags: atp.Status=draft	
Available via	Dcm_Externals.h	

D.6.1.2 WriteData

If `DcmDspDataType` is set to `USE_DATA_SYNCH_FNC_PROXY`, the following definition is used:

Service Name	Xxx_WriteData (draft)	
Syntax	<pre>Std_ReturnType Xxx_WriteData (const uint8* Data, uint16 DataLength, Dcm_NegativeResponseCodeType* ErrorCode)</pre>	
Service ID [hex]	0x70	
Sync/Async	Synchronous	





Reentrancy	Non Reentrant	
Parameters (in)	Data	Buffer containing the data to be written
	DataLength	Length in byte of the data to be written
Parameters (inout)	None	
Parameters (out)	ErrorCode	If the operation Xxx_WriteData returns value E_NOT_OK, the DCM module shall send a negative response with NRC code equal to the parameter ErrorCode parameter value.
Return value	Std_ReturnType	E_OK: Request was successful. E_NOT_OK: Request was not successful.
Description	This function requests the application to write a data value of a DID if DcmDspDataUsePort is set to USE_DATA_SYNCH_FNC_PROXY. Tags: atp.Status=draft	
Available via	Dcm_Externals.h	

If `DcmDspDataType` is set to `USE_DATA_ASYNC_FNC_PROXY`, the following definition is used:

Service Name	Xxx_WriteData (draft)	
Syntax	<pre>Std_ReturnType Xxx_WriteData (const uint8* Data, uint16 DataLength, Dcm_OpStatusType OpStatus, Dcm_NegativeResponseType* ErrorCode)</pre>	
Service ID [hex]	0x71	
Sync/Async	Asynchronous	
Reentrancy	Non Reentrant	
Parameters (in)	Data	Buffer containing the data to be written
	DataLength	Length in byte of the data to be written
	OpStatus	Status of the current operation
Parameters (inout)	None	
Parameters (out)	ErrorCode	If the operation Xxx_WriteData returns value E_NOT_OK, the DCM module shall send a negative response with NRC code equal to the parameter ErrorCode parameter value.
Return value	Std_ReturnType	E_OK: Request was successful. E_NOT_OK: Request was not successful. DCM_E_PENDING: Request is not yet finished. Further call(s) required to finish.
Description	This function requests the application to write a data value of a DID if DcmDspDataUsePort is set to USE_DATA_ASYNC_FNC_PROXY. Tags: atp.Status=draft	
Available via	Dcm_Externals.h	

D.6.1.3 ConditionCheckRead

If `DcmDspDataUsePort` is set to `USE_DATA_ASYNC_CLIENT_SERVER` or `USE_DATA_ASYNC_FNC`, or `USE_DATA_ASYNC_CLIENT_SERVER_ERROR`, `USE_DATA_ASYNC_FNC_ERROR` or `USE_DATA_ASYNC_FNC_PROXY`, the following definition is used:

Service Name	Xxx_ConditionCheckRead	
Syntax	Std_ReturnType Xxx_ConditionCheckRead (Dcm_OpStatusType OpStatus, Dcm_NegativeResponseCodeType* ErrorCode)	
Service ID [hex]	0x37	
Sync/Async	Asynchronous	
Reentrancy	Non Reentrant	
Parameters (in)	OpStatus	Status of the current operation
Parameters (inout)	None	
Parameters (out)	ErrorCode	If the operation Xxx_ConditionCheckRead returns value E_NOT_OK, the DCM module shall send a negative response with NRC code equal to the parameter ErrorCode parameter value.
Return value	Std_ReturnType	E_OK: Request was successful. E_NOT_OK: Request was not successful. DCM_E_PENDING: Request is not yet finished. Further call(s) required to finish.
Description	This function requests to the application if the conditions to read the Data are correct.	
Available via	Dcm_Externals.h	

D.6.1.4 ReadDataLength

If `DcmDspDataUsePort` is set to `USE_DATA_SYNCH_CLIENT_SERVER`, or `USE_DATA_SYNCH_FNC`, or `USE_DATA_SYNCH_FNC_PROXY`, the following definition is used:

Service Name	Xxx_ReadDataLength (draft)	
Syntax	Std_ReturnType Xxx_ReadDataLength (uint16* DataLength)	
Service ID [hex]	0x36	
Sync/Async	Synchronous	
Reentrancy	Non Reentrant	
Parameters (in)	None	
Parameters (inout)	None	
Parameters (out)	DataLength	Length in byte of the data to be read
Return value	Std_ReturnType	E_OK: Request was successful. E_NOT_OK: Request was not successful.
Description	This function requests the application to return the data length in byte of a Data. Tags: atp.Status=draft	
Available via	Dcm_Externals.h	

If `DcmDspDataUsePort` is set to `USE_DATA_ASYNC_CLIENT_SERVER` or `USE_DATA_ASYNC_CLIENT_SERVER_ERROR` or `USE_DATA_ASYNC_FNC` or `USE_DATA_ASYNC_FNC_ERROR`, or `USE_DATA_SYNCH_FNC_PROXY`, or `USE_DATA_ASYNC_FNC_PROXY`, the following definition is used:

Service Name	Xxx_ReadDataLength (draft)	
Syntax	Std_ReturnType Xxx_ReadDataLength (Dcm_OpStatusType OpStatus, uint16* DataLength)	
Service ID [hex]	0x4c	
Sync/Async	Asynchronous	
Reentrancy	Non Reentrant	
Parameters (in)	OpStatus	Status of the current operation
Parameters (inout)	None	
Parameters (out)	DataLength	Length in byte of the data to be read
Return value	Std_ReturnType	E_OK: this value is always returned. E_NOT_OK: Request was not successful. DCM_E_PENDING: Request is not yet finished. Further call(s) required to finish.
Description	This function requests the application to return the data length in byte of a Data. Tags: atp.Status=draft	
Available via	Dcm_Externals.h	

D.6.1.5 GetScalingInformation

If `DcmDspDataUsePort` is set to `USE_DATA_SYNCH_FNC_PROXY`, the following definition is used:

Service Name	Xxx_GetScalingInformation (draft)	
Syntax	Std_ReturnType Xxx_GetScalingInformation (uint8* ScalingInfo, uint8 ScalingInfoLength, Dcm_NegativeResponseType* ErrorCode)	
Service ID [hex]	0x72	
Sync/Async	Synchronous	
Reentrancy	Non Reentrant	
Variation	({ecuc(Dcm/DcmConfigSet/DcmDsp/DcmDspData.DcmDspDataUsePort)}== (USE_DATA_SYNCH_FNC_PROXY) && ({ecuc(Dcm/DcmConfigSet/DcmDsp/DcmDspData/DcmDspDataInfoRef->DcmDspDataScalingInfoSize)} != NULL))	
Parameters (in)	ScalingInfoLength	Length in byte of the scaling information to be read
Parameters (inout)	None	
Parameters (out)	ScalingInfo	Scaling information (scalingByte and scalingByteExtension)
	ErrorCode	If the operation <code>Xxx_GetScalingInformation</code> returns value <code>E_NOT_OK</code> , the DCM module shall send a negative response with NRC code equal to the parameter <code>ErrorCode</code> parameter value.
Return value	Std_ReturnType	E_OK: Request was successful. E_NOT_OK: Request was not successful.
Description	This function requests to the application for the scaling information of a Data. Tags: atp.Status=draft	
Available via	Dcm_Externals.h	

If `DcmDspDataUsePort` is set to `USE_DATA_ASYNC_FNC_PROXY`, the following definition is used:

Service Name	Xxx_GetScalingInformation (draft)	
Syntax	<pre>Std_ReturnType Xxx_GetScalingInformation (Dcm_OpStatusType OpStatus, uint8* ScalingInfo, uint8 ScalingInfoLength, Dcm_NegativeResponseCodeType* ErrorCode)</pre>	
Service ID [hex]	0x73	
Sync/Async	Asynchronous	
Reentrancy	Non Reentrant	
Variation	$(\{ecuc(Dcm/DcmConfigSet/DcmDsp/DcmDspData.DcmDspDataUsePort)\} == (USE_DATA_ASYNC_FNC_PROXY) \ \&\& \ (\{ecuc(Dcm/DcmConfigSet/DcmDsp/DcmDspData/DcmDspDataInfoRef->DcmDspDataScalingInfoSize)\} \neq NULL)$	
Parameters (in)	OpStatus	Status of the current operation
	ScalingInfoLength	Length in byte of the scaling information to be read
Parameters (inout)	None	
Parameters (out)	ScalingInfo	Scaling information (scalingByte and scalingByteExtension)
	ErrorCode	If the operation <code>Xxx_GetScalingInformation</code> returns value <code>E_NOT_OK</code> , the DCM module shall send a negative response with NRC code equal to the parameter <code>ErrorCode</code> parameter value.
Return value	Std_ReturnType	<code>E_OK</code> : Request was successful. <code>E_NOT_OK</code> : Request was not successful. <code>DCM_E_PENDING</code> : Request is not yet finished. Further call(s) required to finish.
Description	This function requests to the application for the scaling information of a Data. Tags: atp.Status=draft	
Available via	Dcm_Externals.h	

D.6.1.6 ReturnControlToECU

If `DcmDspDataUsePort` is set to `USE_DATA_SYNC_FNC_PROXY` or `USE_DATA_ASYNC_FNC_PROXY`, the following definition is used:

Service Name	Xxx_ReturnControlToECU (draft)	
Syntax	<pre>Std_ReturnType Xxx_ReturnControlToECU (uint8* controlMask, uint8 controlMaskLength, Dcm_NegativeResponseCodeType ErrorCode)</pre>	
Service ID [hex]	0x74	
Sync/Async	Synchronous	
Reentrancy	Non Reentrant	
Variation	$(\{ecuc(Dcm/DcmConfigSet/DcmDsp/DcmDspData.DcmDspDataUsePort)\} == (USE_DATA_SYNC_FNC_PROXY \ \ USE_DATA_ASYNC_FNC_PROXY) \ \&\& \ (\{ecuc(Dcm/DcmConfigSet/DcmDsp/DcmDspDid/DcmDspDidInfoRef->DcmDspDidInfo/DcmDspDidControl)\} \neq NULL)$	
Parameters (in)	controlMask	Control enable mask





	controlMaskLength	Control enable mask length in byte
Parameters (inout)	None	
Parameters (out)	ErrorCode	If the operation Xxx_ReturnControlToECU returns value E_NOT_OK, the DCM module shall send a negative response with NRC code equal to the parameter ErrorCode parameter value.
Return value	Std_ReturnType	E_OK: Request was successful. E_NOT_OK: Request was not successful.
Description	This function requests to the application to return control to ECU of an IOControl. Tags: atp.Status=draft	
Available via	Dcm_Externals.h	

D.6.1.7 ResetToDefault

If `DcmDspDataUsePort` is set to `USE_DATA_SYNCH_FNC_PROXY`, the following definition is used:

Service Name	Xxx_ResetToDefault (draft)	
Syntax	<pre>Std_ReturnType Xxx_ResetToDefault (uint8* controlMask, uint8 controlMaskLength, Dcm_NegativeResponseCodeType* ErrorCode)</pre>	
Service ID [hex]	0x75	
Sync/Async	Synchronous	
Reentrancy	Non Reentrant	
Variation	<code>((ecuc(Dcm/DcmConfigSet/DcmDsp/DcmDspData.DcmDspDataUsePort)) == USE_DATA_SYNCH_FNC_PROXY) && ((ecuc(Dcm/DcmConfigSet/DcmDsp/DcmDspDidInfo/DcmDspDidControl/DcmDspDidResetToDefault)) == TRUE)</code>	
Parameters (in)	controlMask	Control enable mask
	controlMaskLength	Control enable mask length in byte
Parameters (inout)	None	
Parameters (out)	ErrorCode	If the operation Xxx_ResetToDefault returns value E_NOT_OK, the DCM module shall send a negative response with NRC code equal to the parameter ErrorCode parameter value.
Return value	Std_ReturnType	E_OK: Request was successful. E_NOT_OK: Request was not successful.
Description	This function requests to the application to reset an IOControl to default value. Tags: atp.Status=draft	
Available via	Dcm_Externals.h	

If `DcmDspDataUsePort` is set to `USE_DATA_ASYNC_CLIENT_SERVER` or `USE_DATA_ASYNC_FNC` or `USE_DATA_ASYNC_CLIENT_SERVER_ERROR` or `USE_DATA_ASYNC_FNC_ERROR`, the following definition is used:

Service Name	Xxx_ResetToDefault	
Syntax	<pre>Std_ReturnType Xxx_ResetToDefault (Dcm_OpStatusType OpStatus, [Dcm_ControlMask_{DID}Type controlMask], [uint8* controlMask], Dcm_NegativeResponseCodeType* ErrorCode)</pre>	
Service ID [hex]	0x3c	
Sync/Async	Asynchronous	
Reentrancy	Non Reentrant	
Variation	({ecuc(Dcm/DcmConfigSet/DcmDsp/DcmDspData.DcmDspDataUsePort)} == (USE_DATA_ASYNC_FNC USE_DATA_ASYNC_FNC_ERROR USE_DATA_ASYNC_CLIENT_SERVER USE_DATA_ASYNC_CLIENT_SERVER_ERROR)) && ({ecuc(Dcm/DcmConfigSet/DcmDsp/DcmDspDidInfo/DcmDspDidControl/DcmDspDidResetToDefault)} == TRUE)	
Parameters (in)	OpStatus	Status of the current operation
	controlMask	–
	Type	Dcm_ControlMask_{DID}Type
	Variation	({ecuc(Dcm/DcmConfigSet/DcmDsp/DcmDspDid/DcmDspDidInfoRef -> DcmDspDidInfo/DcmDspDidControl/DcmDspDidControlMask)} == DCM_CONTROLMASK_EXTERNAL)&& ({ecuc(Dcm/DcmConfigSet/DcmDsp/DcmDspDid/DcmDspDidInfoRef->DcmDspDidInfo/DcmDspDidControl/DcmDspDidControlMaskSize)} <= 0x04)
	controlMask	–
	Type	uint8*
Variation	({ecuc(Dcm/DcmConfigSet/DcmDsp/DcmDspData.DcmDspDataUsePort)} == (USE_DATA_ASYNC_CLIENT_SERVER USE_DATA_ASYNC_CLIENT_SERVER_ERROR)) && ({ecuc(Dcm/DcmConfigSet/DcmDsp/DcmDspDid/DcmDspDidInfoRef -> DcmDspDidInfo/DcmDspDidControl/DcmDspDidControlMask)} == DCM_CONTROLMASK_EXTERNAL)&& ({ecuc(Dcm/DcmConfigSet/DcmDsp/DcmDspDid/DcmDspDidInfoRef->DcmDspDidInfo/DcmDspDidControl/DcmDspDidControlMaskSize)} => 0x05)	
Parameters (inout)	None	
Parameters (out)	ErrorCode	If the operation Xxx_ResetToDefault returns value E_NOT_OK, the DCM module shall send a negative response with NRC code equal to the parameter ErrorCode parameter value.
Return value	Std_ReturnType	E_OK: Request was successful. E_NOT_OK: Request was not successful. DCM_E_PENDING: Request is not yet finished. Further call(s) required to finish.
Description	This function requests to the application to reset an IOControl to default value.	
Available via	Dcm_Externals.h	

Note: Square brackets [] indicate that an argument is optional.

D.6.1.8 FreezeCurrentState

If [DcmDspDataUsePort](#) is set to [USE_DATA_SYNCH_FNC_PROXY](#), the following definition is used:

Service Name	Xxx_FreezeCurrentState (draft)	
Syntax	<pre>Std_ReturnType Xxx_FreezeCurrentState (uint8* controlMask, uint8 controlMaskLength, Dcm_NegativeResponseCodeType* ErrorCode)</pre>	
Service ID [hex]	0x77	
Sync/Async	Synchronous	
Reentrancy	Non Reentrant	
Variation	({ecuc(Dcm/DcmConfigSet/DcmDsp/DcmDspData.DcmDspDataUsePort)}== USE_DATA_SYNCH_FNC_PROXY) && ({ecuc(Dcm/DcmConfigSet/DcmDsp/DcmDspDidInfo/DcmDspDidControl/DcmDspDidFreezeCurrentState)} == TRUE)	
Parameters (in)	controlMask	Control enable mask
	controlMaskLength	Control enable mask length in byte
Parameters (inout)	None	
Parameters (out)	ErrorCode	If the operation Xxx_FreezeCurrentState returns value E_NOT_OK, the DCM module shall send a negative response with NRC code equal to the parameter ErrorCode parameter value.
Return value	Std_ReturnType	E_OK: Request was successful. E_NOT_OK: Request was not successful.
Description	This function requests to the application to freeze the current state of an IOControl. Tags: atp.Status=draft	
Available via	Dcm_Externals.h	

If `DcmDspDataUsePort` is set to `USE_DATA_ASYNC_FNC_PROXY`, the following definition is used:

Service Name	Xxx_FreezeCurrentState (draft)	
Syntax	<pre>Std_ReturnType Xxx_FreezeCurrentState (Dcm_OpStatusType OpStatus, uint8* controlMask, uint8 controlMaskLength, Dcm_NegativeResponseCodeType* ErrorCode)</pre>	
Service ID [hex]	0x78	
Sync/Async	Asynchronous	
Reentrancy	Non Reentrant	
Variation	({ecuc(Dcm/DcmConfigSet/DcmDsp/DcmDspData.DcmDspDataUsePort)}== USE_DATA_ASYNC_FNC_PROXY) && ({ecuc(Dcm/DcmConfigSet/DcmDsp/DcmDspDidInfo/DcmDspDidControl/DcmDspDidFreezeCurrentState)} == TRUE)	
Parameters (in)	OpStatus	Status of the current operation
	controlMask	Control enable mask
	controlMaskLength	Control enable mask length in byte
Parameters (inout)	None	
Parameters (out)	ErrorCode	If the operation Xxx_FreezeCurrentState returns value E_NOT_OK, the DCM module shall send a negative response with NRC code equal to the parameter ErrorCode parameter value.
Return value	Std_ReturnType	E_OK: Request was successful. E_NOT_OK: Request was not successful. DCM_E_PENDING: Request is not yet finished. Further call(s) required to finish.





Description	This function requests to the application to freeze the current state of an IOControl. Tags: atp.Status=draft
Available via	Dcm_Externals.h

D.6.1.9 ShortTermAdjustment

If `DcmDspDataUsePort` is set to `USE_DATA_SYNCH_FNC_PROXY`, the following definition is used:

Service Name	Xxx_ShortTermAdjustment (draft)	
Syntax	<pre>Std_ReturnType Xxx_ShortTermAdjustment (const uint8* ControlStateInfo, uint16 DataLength, uint8* controlMask, uint8 controlMaskLength, Dcm_NegativeResponseCodeType* ErrorCode)</pre>	
Service ID [hex]	0x79	
Sync/Async	Synchronous	
Reentrancy	Non Reentrant	
Variation	<code>((ecuc(Dcm/DcmConfigSet/DcmDsp/DcmDspData.DcmDspDataUsePort)) == USE_DATA_SYNCH_FNC_PROXY) && ((ecuc(Dcm/DcmConfigSet/DcmDsp/DcmDspDidInfo/DcmDspDidControl/DcmDspDidShortTermAdjustment)) == TRUE)</code>	
Parameters (in)	ControlStateInfo	ControlState information contained in the ControlOptionRecord parameter of the InputOutputControlByIdentifier diagnostic request
	DataLength	ControlState information length in byte
	controlMask	Control enable mask
	controlMaskLength	Control enable mask length in byte
Parameters (inout)	None	
Parameters (out)	ErrorCode	If the operation <code>Xxx_ShortTermAdjustment</code> returns value <code>E_NOT_OK</code> , the DCM module shall send a negative response with NRC code equal to the parameter <code>ErrorCode</code> parameter value.
Return value	Std_ReturnType	<code>E_OK</code> : Request was successful. <code>E_NOT_OK</code> : Request was not successful.
Description	This function requests to the application to adjust the IO signal. Tags: atp.Status=draft	
Available via	Dcm_Externals.h	

If `DcmDspDataUsePort` is set to `USE_DATA_ASYNC_FNC_PROXY`, the following definition is used:

Service Name	Xxx_ShortTermAdjustment (draft)	
Syntax	<pre>Std_ReturnType Xxx_ShortTermAdjustment (const uint8* ControlStateInfo, uint16 DataLength, Dcm_OpStatusType OpStatus, uint8* controlMask, uint8 controlMaskLength, Dcm_NegativeResponseCodeType* ErrorCode)</pre>	
Service ID [hex]	0x83	
Sync/Async	Synchronous	
Reentrancy	Non Reentrant	
Variation	({ecuc(Dcm/DcmConfigSet/DcmDsp/DcmDspData.DcmDspDataUsePort)}== USE_DATA_ ASYNCH_FNC_PROXY) && ({ecuc(Dcm/DcmConfigSet/DcmDsp/DcmDspDidInfo/DcmDspDidControl/DcmDspDidShortTermAdjustment)} == TRUE)	
Parameters (in)	ControlStateInfo	ControlState information contained in the ControlOptionRecord parameter of the InputOutputControlByIdentifier diagnostic request
	DataLength	ControlState information length in byte
	OpStatus	Status of the current operation
	controlMask	Control enable mask
	controlMaskLength	Control enable mask length in byte
Parameters (inout)	None	
Parameters (out)	ErrorCode	If the operation Xxx_ShortTermAdjustment returns value E_NOT_OK, the DCM module shall send a negative response with NRC code equal to the parameter ErrorCode parameter value.
Return value	Std_ReturnType	E_OK: Request was successful. E_NOT_OK: Request was not successful DCM_E_PENDING: Request is not yet finished. Further call(s) required to finish.
Description	This function requests to the application to adjust the IO signal. Tags: atp.Status=draft	
Available via	Dcm_Externals.h	

D.6.2 RoutineServices

D.6.2.1 Xxx_Start Operation

Service Name	Xxx_Start (draft)	
Syntax	<pre>Std_ReturnType Xxx_Start (Dcm_OpStatusType OpStatus, uint8* dataInOut, uint16* currentDataLength, Dcm_NegativeResponseCodeType* ErrorCode)</pre>	
Service ID [hex]	0x80	
Sync/Async	Asynchronous	
Reentrancy	Non Reentrant	
Parameters (in)	OpStatus	Status of the current operation





Parameters (inout)	dataInOut	Input and output data in the routine control request / response
	currentDataLength	This parameter contains the length in bytes of the dataInOut array. It include fixed length and variable length data.
Parameters (out)	ErrorCode	If the operation Xxx_Start returns value E_NOT_OK, the Dcm module shall send a negative response with NRC code equal to the parameter ErrorCode parameter value.
Return value	Std_ReturnType	E_OK: Request was successful. E_NOT_OK: Request was not successful. DCM_E_PENDING: Request is not yet finished. Further call(s) required to finish. DCM_E_FORCE_RCRRP: application requests the transmission of a response Pending (NRC 0x78)
Description	This function requests to the application to start the execution of a routine. Tags: atp.Status=draft	
Available via	Dcm_Externals.h	

D.6.2.2 Xxx_StartConfirmation Operation

If `DcmDspRoutineFncSignature` is set to `ROUTINE_FNC_NORMAL` or `ROUTINE_FNC_PROXY`, the following definition is used:

Service Name	Xxx_StartConfirmation	
Syntax	Std_ReturnType Xxx_StartConfirmation (Dcm_ConfirmationStatusType ConfirmationStatus)	
Sync/Async	Synchronous	
Reentrancy	Non Reentrant	
Parameters (in)	ConfirmationStatus	Confirmation status of a StartRoutine request
Parameters (inout)	None	
Parameters (out)	None	
Return value	Std_ReturnType	E_OK: Request was successful. E_NOT_OK: Request was not successful.
Description	This function indicates the transmission of a response to a StartRoutine request	
Available via	Dcm_Externals.h	

D.6.2.3 Xxx_Stop Operation

If `DcmDspRoutineFncSignature` is set to `ROUTINE_FNC_PROXY`, the following definition is used:

Service Name	Xxx_Stop (draft)	
Syntax	<pre>Std_ReturnType Xxx_Stop (Dcm_OpStatusType OpStatus, uint8* dataInOut, uint16* currentDataLength, Dcm_NegativeResponseCodeType* ErrorCode)</pre>	
Service ID [hex]	0x81	
Sync/Async	Asynchronous	
Reentrancy	Non Reentrant	
Parameters (in)	OpStatus	Status of the current operation
Parameters (inout)	dataInOut	Input and output data in the routine control request / response
	currentDataLength	This parameter contains the length in bytes of the dataInOut array. It include fixed length and variable length data.
Parameters (out)	ErrorCode	If the operation Xxx_Stop returns value E_NOT_OK, the Dcm module shall send a negative response with NRC code equal to the parameter ErrorCode parameter value.
Return value	Std_ReturnType	E_OK: Request was successful. E_NOT_OK: Request was not successful. DCM_E_PENDING: Request is not yet finished. Further call(s) required to finish DCM_E_FORCE_RCRRP: application requests the transmission of a response Pending (NRC 0x78)
Description	This function requests to the application to stop the execution of a routine Tags: atp.Status=draft	
Available via	Dcm_Externals.h	

D.6.2.4 Xxx_StopConfirmation Operation

If `DcmDspRoutineFncSignature` is set to `ROUTINE_FNC_NORMAL` or `ROUTINE_FNC_PROXY`, the following definition is used:

Service Name	Xxx_StopConfirmation	
Syntax	<pre>Std_ReturnType Xxx_StopConfirmation (Dcm_ConfirmationStatusType ConfirmationStatus)</pre>	
Service ID [hex]	0x69	
Sync/Async	Synchronous	
Reentrancy	Non Reentrant	
Parameters (in)	ConfirmationStatus	Dcm_ConfirmationStatus Confirmation status of a StopRoutine request
Parameters (inout)	None	
Parameters (out)	None	
Return value	Std_ReturnType	E_OK: Request was successful. E_NOT_OK: Request was not successful.
Description	This function indicates the transmission of a response to a StopRoutine request	
Available via	Dcm_Externals.h	

D.6.2.5 Xxx_RequestResults Operation

If `DcmDspRoutineFncSignature` is set to `ROUTINE_FNC_PROXY`, the following definition is used:

Service Name	Xxx_RequestResults (draft)	
Syntax	<pre>Std_ReturnType Xxx_RequestResults (Dcm_OpStatusType OpStatus, uint8* dataInOut, uint16* currentDataLength, Dcm_NegativeResponseCodeType* ErrorCode)</pre>	
Service ID [hex]	0x82	
Sync/Async	Asynchronous	
Reentrancy	Non Reentrant	
Parameters (in)	OpStatus	Status of the current operation
Parameters (inout)	dataInOut	Input and output data in the routine control request / response. If variable length routine input data is used, this parameter contains the length in bytes of the dataInVar array. If variable length routine output data is used, this parameter contains the length in bytes of the dataOutVar parameter.
	currentDataLength	This parameter contains the length in bytes of the dataInOut array. It includes fixed length and variable length data.
Parameters (out)	ErrorCode	If the operation Xxx_RequestResults returns value E_NOT_OK, the Dcm module shall send a negative response with N.
Return value	Std_ReturnType	E_OK: Request was successful. E_NOT_OK: Request was not successful. DCM_E_PENDING: Request is not yet finished. Further call(s) required to finish. DCM_E_FORCE_RCRRP: application requests the transmission of a response Pending (NRC 0x78)
Description	This function requests to the application the result of a routine execution. Tags: atp.Status=draft	
Available via	Dcm_Externals.h	

D.6.2.6 Xxx_RequestResultsConfirmation Operation

If `DcmDspRoutineFncSignature` is set to `ROUTINE_FNC_NORMAL` or `ROUTINE_FNC_PROXY`, the following definition is used:

Service Name	Xxx_RequestResultsConfirmation	
Syntax	<pre>Std_ReturnType Xxx_RequestResultsConfirmation (Dcm_ConfirmationStatusType ConfirmationStatus)</pre>	
Service ID [hex]	0x70	
Sync/Async	Synchronous	
Reentrancy	Non Reentrant	
Parameters (in)	ConfirmationStatus	Confirmation status of a RequestRoutineResults request
Parameters (inout)	None	
Parameters (out)	None	





Return value	Std_ReturnType	E_OK: Request was successful. E_NOT_OK: Request was not successful.
Description	This function indicates the transmission of a response to a RequestRoutineResults request	
Available via	Dcm_Externals.h	

D.6.3 ServiceRequestNotification

From the point of view of the DCM, the operations has the following signatures:

D.6.3.1 Indication

Service Name	Xxx_Indication	
Syntax	<pre>Std_ReturnType Xxx_Indication (uint8 SID, const uint8* RequestData, uint32 DataSize, uint8 ReqType, uint16 ConnectionId, Dcm_NegativeResponseCodeType* ErrorCode, Dcm_ProtocolType ProtocolType, uint16 TesterSourceAddress)</pre>	
Service ID [hex]	0x65	
Sync/Async	Synchronous	
Reentrancy	Non Reentrant	
Parameters (in)	SID	–
	RequestData	Complete request data (diagnostic buffer), except the service ID
	DataSize	Number of valid bytes in the RequestData parameter
	ReqType	Addressing type of the request(0=physical request,1=functional request)
	ConnectionId	Unique connection identifier
	ProtocolType	Type of the protocol to be indicated
	TesterSourceAddress	source address of the tester
Parameters (inout)	None	
Parameters (out)	ErrorCode	If the operation Xxx_Indication re- turns value E_NOT_OK, the Dcm module shall send a negative response with NRC code equal to the parameter ErrorCode parameter value
Return value	Std_ReturnType	E_OK: Request was successful. E_NOT_OK: Request was not successful. E_REQUEST_NOT_ACCEPTED : Request not accepted
Description	This function indicates to the application that a service is about to be executed and allows the application to reject the execution of the service request	
Available via	Dcm_Externals.h	

D.6.3.2 Confirmation

Service Name	Xxx_Confirmation	
Syntax	<pre>Std_ReturnType Xxx_Confirmation (uint8 SID, uint8 ReqType, uint16 ConnectionId, Dcm_ConfirmationStatusType ConfirmationStatus, Dcm_ProtocolType ProtocolType, uint16 TesterSourceAddress)</pre>	
Service ID [hex]	0x66	
Sync/Async	Synchronous	
Reentrancy	Non Reentrant	
Parameters (in)	SID	Value of service identifier
	ReqType	Addressing type of the request(0=physical request,1=functional request)
	ConnectionId	Unique connection identifier
	ConfirmationStatus	Confirmation of a successful transmission or a transmission error of a diagnostic service.
	ProtocolType	Type of Dcm Protocol
	TesterSourceAddress	source address of the tester
Parameters (inout)	None	
Parameters (out)	None	
Return value	Std_ReturnType	E_OK: Request was successful. E_NOT_OK: Request was not successful.
Description	This function confirms to the application the successful transmission or a transmission error of a diagnostic service.	
Available via	Dcm_Externals.h	

D.7 Dem

D.7.1 Dem_ClearPrestoredFreezeFrame

Service Name	Dem_ClearPrestoredFreezeFrame	
Syntax	<pre>Std_ReturnType Dem_ClearPrestoredFreezeFrame (Dem_EventIdType EventId)</pre>	
Service ID [hex]	0x07	
Sync/Async	Synchronous	
Reentrancy	Reentrant for different EventIds. Non reentrant for the same EventId.	
Parameters (in)	EventId	Identification of an event by assigned EventId.
Parameters (inout)	None	
Parameters (out)	None	
Return value	Std_ReturnType	E_OK: Clear prestored freeze frame was successful E_NOT_OK: Clear prestored freeze frame failed





Description	<p>Clears a prestored freeze frame of a specific event. This API can only be used through the RTE and therefore no declaration is exported via Dem.h.</p> <p>API Availability: This API will be available only if $\{\{ecuc(Dem/DemConfigSet/DemEventParameter.DemFFPrestorageSupported)\} == true\}$</p>
Available via	Dem.h

D.7.2 Dem_PrestoreFreezeFrame

Service Name	Dem_PrestoreFreezeFrame	
Syntax	<pre>Std_ReturnType Dem_PrestoreFreezeFrame (Dem_EventIdType EventId)</pre>	
Service ID [hex]	0x06	
Sync/Async	Synchronous	
Reentrancy	Reentrant for different EventIds. Non reentrant for the same EventId.	
Parameters (in)	EventId	Identification of an event by assigned EventId.
Parameters (inout)	None	
Parameters (out)	None	
Return value	Std_ReturnType	E_OK Freeze frame prestorage was successful E_NOT_OK Freeze frame prestorage failed
Description	<p>Captures the freeze frame data for a specific event. This API can only be used through the RTE and therefore no declaration is exported via Dem.h.</p> <p>API Availability: This API will be available only if $\{\{ecuc(Dem/DemConfigSet/DemEventParameter.DemFFPrestorageSupported)\} == true\}$</p>	
Available via	Dem.h	

D.7.3 Dem_ResetEventDebounceStatus

Service Name	Dem_ResetEventDebounceStatus	
Syntax	<pre>Std_ReturnType Dem_ResetEventDebounceStatus (Dem_EventIdType EventId, Dem_DebounceResetStatusType DebounceResetStatus)</pre>	
Service ID [hex]	0x09	
Sync/Async	Synchronous	
Reentrancy	Reentrant for different EventIds. Non reentrant for the same EventId.	
Parameters (in)	EventId	Identification of an event by assigned EventId.
	DebounceResetStatus	Freeze or reset the internal debounce counter/timer of the specified event.
Parameters (inout)	None	
Parameters (out)	None	
Return value	Std_ReturnType	E_OK: Operation was successful E_NOT_OK: Only on development error





Description	Control the internal debounce counter/timer by BSW modules and SW-Cs. The event qualification will not be affected by these debounce state changes. This API is available for BSW modules as soon as Dem_Prenit has been completed (refer to SWS_Dem_00438 and SWS_Dem_00167).
Available via	Dem.h

D.7.4 Dem_ResetEventStatus

Service Name	Dem_ResetEventStatus	
Syntax	Std_ReturnType Dem_ResetEventStatus (Dem_EventIdType EventId)	
Service ID [hex]	0x05	
Sync/Async	Asynchronous	
Reentrancy	Reentrant for different EventIds. Non reentrant for the same EventId.	
Parameters (in)	EventId	Identification of an event by assigned EventId.
Parameters (inout)	None	
Parameters (out)	None	
Return value	Std_ReturnType	E_OK: Request to reset the event status was successful accepted. E_NOT_OK: Request to reset the event status failed or is not allowed, because the event is already tested in this operation cycle.
Description	Resets the event failed status. This API can only be used through the RTE and therefore no declaration is exported via Dem.h.	
Available via	Dem.h	

D.7.5 Dem_SetEventDisabled

Service Name	Dem_SetEventDisabled	
Syntax	Std_ReturnType Dem_SetEventDisabled (Dem_EventIdType EventId)	
Service ID [hex]	0x51	
Sync/Async	Synchronous	
Reentrancy	Reentrant for different EventIds. Non reentrant for the same EventId.	
Parameters (in)	EventId	Identification of an event by assigned EventId.
Parameters (inout)	None	
Parameters (out)	None	
Return value	Std_ReturnType	E_OK set of event to disabled was successfull. E_NOT_OK set of event disabled failed





Description	Service for reporting the event as disabled to the Dem for the PID \$41 computation. API is needed in OBD-relevant ECUs only. API Availability: This API will be available only if $\{(\text{ecuc}(\text{Dem}/\text{DemGeneral}.\text{DemOBDSupport}) \neq \text{DEM_OBD_NO_OBD_SUPPORT})\}$
Available via	Dem.h

D.7.6 Dem_SetEventStatus

Service Name	Dem_SetEventStatus	
Syntax	<pre>Std_ReturnType Dem_SetEventStatus (Dem_EventIdType EventId, Dem_EventStatusType EventStatus)</pre>	
Service ID [hex]	0x04	
Sync/Async	Synchronous	
Reentrancy	Reentrant for different EventIds. Non reentrant for the same EventId.	
Parameters (in)	EventId	Identification of an event by assigned EventId.
	EventStatus	Monitor test result
Parameters (inout)	None	
Parameters (out)	None	
Return value	Std_ReturnType	E_OK: set of event status was successful E_NOT_OK: Event status setting or processing failed or could not be accepted.
Description	Called by SW-Cs or BSW modules to report monitor status information to the Dem. BSW modules calling Dem_SetEventStatus can safely ignore the return value. This API will be available only if $\{(\text{Dem}/\text{DemConfigSet}/\text{DemEventParameter}/\text{DemEventReportingType}) == \text{STANDARD_REPORTING}\}$	
Available via	Dem.h	

D.7.7 Dem_GetDTCOfEvent

Service Name	Dem_GetDTCOfEvent	
Syntax	<pre>Std_ReturnType Dem_GetDTCOfEvent (Dem_EventIdType EventId, Dem_DTCFormatType DTCFormat, uint32* DTCOfEvent)</pre>	
Service ID [hex]	0x0d	
Sync/Async	Synchronous	
Reentrancy	Reentrant	
Parameters (in)	EventId	Identification of an event by assigned EventId.
	DTCFormat	Defines the output-format of the requested DTC value.
Parameters (inout)	None	





Parameters (out)	DTCOfEvent	Receives the DTC value in respective format returned by this function. If the return value of the function is other than E_OK this parameter does not contain valid data.
Return value	Std_ReturnType	E_OK: get of DTC was successful E_NOT_OK: the call was not successful DEM_E_NO_DTC_AVAILABLE: there is no DTC configured in the requested format
Description	Gets the DTC of an event.	
Available via	Dem.h	

D.7.8 Dem_GetDebouncingOfEvent

Service Name	Dem_GetDebouncingOfEvent	
Syntax	Std_ReturnType Dem_GetDebouncingOfEvent (Dem_EventIdType EventId, Dem_DebouncingStateType* DebouncingState)	
Service ID [hex]	0x9f	
Sync/Async	Synchronous	
Reentrancy	Reentrant	
Parameters (in)	EventId	Identification of an event by assigned EventId.
Parameters (inout)	None	
Parameters (out)	DebouncingState	Bit 0 Temporarily Defective (corresponds to 0 < FDC < 127) Bit 1 finally Defective (corresponds to FDC = 127) Bit 2 temporarily healed (corresponds to -128 < FDC < 0) Bit 3 Test complete (corresponds to FDC = -128 or FDC = 127) Bit 4 DTR Update (= Test complete && Debouncing complete && enable conditions / storage conditions fulfilled)
Return value	Std_ReturnType	E_OK: get of debouncing status per event state successful E_NOT_OK: get of debouncing per event state failed
Description	Gets the debouncing status of an event. This function shall not be used for EventId with native debouncing within their functions. It is rather for EventIds using debouncing within the Dem.	
Available via	Dem.h	

D.7.9 Dem_GetEventAvailable

Service Name	Dem_GetEventAvailable	
Syntax	Std_ReturnType Dem_GetEventAvailable (Dem_EventIdType EventId, boolean* AvailableStatus)	
Service ID [hex]	0xbe	
Sync/Async	Synchronous	
Reentrancy	Reentrant	
Parameters (in)	EventId	Identification of an event by assigned EventId.





Parameters (inout)	None	
Parameters (out)	AvailableStatus	TRUE if the event is available. FALSE if the event is not available.
Return value	Std_ReturnType	E_OK : Event availability has been obtained. E_NOT_OK : Event availability cannot be obtained.
Description	Get the Event's availability.	
Available via	Dem.h	

D.7.10 Dem_GetEventExtendedDataRecordEx

Service Name	Dem_GetEventExtendedDataRecordEx	
Syntax	<pre>Std_ReturnType Dem_GetEventExtendedDataRecordEx (Dem_EventIdType EventId, uint8 RecordNumber, uint8* DestBuffer, uint16* BufSize)</pre>	
Service ID [hex]	0x6d	
Sync/Async	Synchronous	
Reentrancy	Reentrant	
Parameters (in)	EventId	Identification of an event by assigned EventId.
	RecordNumber	Identification of requested Extended data record. Valid values are between 0x01 and 0xEF as defined in ISO14229-1.
Parameters (inout)	BufSize	When the function is called this parameter contains the maximum number of data bytes that can be written to the buffer. The function returns the actual number of written data bytes in this parameter.
Parameters (out)	DestBuffer	This parameter contains a byte pointer that points to the buffer, to which the extended data shall be written to. The format is raw hexadecimal values and contains no header-information.
Return value	Std_ReturnType	E_OK: Operation was successful E_NOT_OK: Operation could not be performed DEM_NO_SUCH_ELEMENT: The requested event data is not currently stored (but the request was valid) OR the requested record number is not supported by the event. DEM_BUFFER_TOO_SMALL: The provided buffer size is too small.
Description	Gets the data of an extended data record by event.	
Available via	Dem.h	

D.7.11 Dem_GetEventFreezeFrameDataEx

Service Name	Dem_GetEventFreezeFrameDataEx	
Syntax	<pre>Std_ReturnType Dem_GetEventFreezeFrameDataEx (Dem_EventIdType EventId, uint8 RecordNumber, uint16 DataId, uint8* DestBuffer, uint16* BufSize)</pre>	
Service ID [hex]	0x6e	
Sync/Async	Synchronous	
Reentrancy	Reentrant	
Parameters (in)	EventId	Identification of an event by assigned EventId.
	RecordNumber	This parameter is a unique identifier for a freeze frame record as defined in ISO14229-1. 0xFF means most recent freeze frame record is returned. 0x00 is only supported if the Dem module supports WWH-OBd (refer to DemOBDSupport)
	DataId	This parameter specifies the DID (ISO14229-1) that shall be copied to the destination buffer.
Parameters (inout)	BufSize	When the function is called this parameter contains the maximum number of data bytes that can be written to the buffer. The function returns the actual number of written data bytes in this parameter.
Parameters (out)	DestBuffer	This parameter contains a byte pointer that points to the buffer, to which the freeze frame data record shall be written to. The format is raw hexadecimal values and contains no header-information.
Return value	Std_ReturnType	<p>E_OK: Operation was successful</p> <p>E_NOT_OK: Operation could not be performed</p> <p>DEM_NO_SUCH_ELEMENT: The requested event data is not currently stored (but the request was valid) OR The requested record number is not supported by the event OR The requested DID is not supported by the freeze frame.</p> <p>DEM_BUFFER_TOO_SMALL: The provided buffer size is too small.</p>
Description	Gets the data of a freeze frame by event.	
Available via	Dem.h	

D.7.12 Dem_GetEventUdsStatus

Service Name	Dem_GetEventUdsStatus	
Syntax	<pre>Std_ReturnType Dem_GetEventUdsStatus (Dem_EventIdType EventId, Dem_UdsStatusByteType* UDSStatusByte)</pre>	
Service ID [hex]	0xb6	
Sync/Async	Synchronous	
Reentrancy	Reentrant	
Parameters (in)	EventId	Identification of an event by assigned EventId.
Parameters (inout)	None	





Parameters (out)	UDSStatusByte	UDS DTC status byte of the requested event (refer to chapter "Status bit support"). If the return value of the function call is E_NOT_OK, this parameter does not contain valid data.
Return value	Std_ReturnType	E_OK: get of event status was successful E_NOT_OK: get of event status failed
Description	Gets the current UDS status byte assigned to the DTC for the event	
Available via	Dem.h	

D.7.13 Dem_GetFaultDetectionCounter

Service Name	Dem_GetFaultDetectionCounter	
Syntax	<pre>Std_ReturnType Dem_GetFaultDetectionCounter (Dem_EventIdType EventId, sint8* FaultDetectionCounter)</pre>	
Service ID [hex]	0x3e	
Sync/Async	Synchronous	
Reentrancy	Non Reentrant	
Parameters (in)	EventId	Identification of an event by assigned EventId.
Parameters (inout)	None	
Parameters (out)	FaultDetectionCounter	This parameter receives the Fault Detection Counter information of the requested EventId. If the return value of the function call is other than E_OK this parameter does not contain valid data. -128dec...127dec PASSED...FAILED according to ISO 14229-1
Return value	Std_ReturnType	E_OK: request was successful E_NOT_OK: request failed DEM_E_NO_FDC_AVAILABLE: there is no fault detection counter available for the requested event
Description	Gets the fault detection counter of an event. This API can only be used through the RTE, and therefore no declaration is exported via Dem.h.	
Available via	Dem.h	

D.7.14 Dem_GetMonitorStatus

Service Name	Dem_GetMonitorStatus	
Syntax	<pre>Std_ReturnType Dem_GetMonitorStatus (Dem_EventIdType EventID, Dem_MonitorStatusType* MonitorStatus)</pre>	
Service ID [hex]	0xb5	
Sync/Async	Synchronous	
Reentrancy	Reentrant	
Parameters (in)	EventID	Identification of an event by assigned EventId.
Parameters (inout)	None	





Parameters (out)	MonitorStatus	Monitor status byte of the requested event. If the return value of the function call is E_NOT_OK, this parameter does not contain valid data.
Return value	Std_ReturnType	E_OK: Get monitor status was successful, E_NOT_OK: getting the monitor status failed.
Description	Gets the current monitor status for an event.	
Available via	Dem.h	

D.7.15 Dem_SetEventStatusWithMonitorData

Service Name	Dem_SetEventStatusWithMonitorData	
Syntax	<pre>Std_ReturnType Dem_SetEventStatusWithMonitorData (Dem_EventIdType EventId, Dem_EventStatusType EventStatus, Dem_MonitorDataType monitorData0, Dem_MonitorDataType monitorData1)</pre>	
Service ID [hex]	0xbd	
Sync/Async	Synchronous/Asynchronous	
Reentrancy	Reentrant for different EventIds. Non reentrant for the same EventId.	
Parameters (in)	EventId	Identification of an event by assigned EventId.
	EventStatus	Monitor test result
	monitorData0	–
	monitorData1	–
Parameters (inout)	None	
Parameters (out)	None	
Return value	Std_ReturnType	E_OK: set of event status was successful E_NOT_OK: Event status setting or processing failed or could not be accepted.
Description	This API will be available only if ({Dem/DemConfigSet/DemEventParameter/DemEventReportingType} == STANDARD_REPORTING_WITH_MONITOR_DATA)	
Available via	Dem.h	

D.7.16 Dem_SetWIRStatus

Service Name	Dem_SetWIRStatus	
Syntax	<pre>Std_ReturnType Dem_SetWIRStatus (Dem_EventIdType EventId, boolean WIRStatus)</pre>	
Service ID [hex]	0x7a	
Sync/Async	Asynchronous	
Reentrancy	Reentrant for different EventIds. Non reentrant for the same EventId.	





Parameters (in)	EventId	Identification of an event by assigned EventId. The Event Number is configured in the DEM. Min.: 1 (0: Indication of no Event or Failure) Max.:Result of configuration of Event Numbers in DEM (Max is either 255 or 65535)
	WIRStatus	Requested status of event related WIR-bit (regarding to the current status of function inhibition) WIRStatus = TRUE -> WIR-bit shall be set to "1" WIRStatus = FALSE -> WIR-bit shall be set to "0"
Parameters (inout)	None	
Parameters (out)	None	
Return value	Std_ReturnType	E_OK: Request to set the WIR status was successful. E_NOT_OK: Request to set the WIR status was not accepted (e.g. disabled controlDTCSetting) and should be repeated.
Description	Sets the WIR status bit via failsafe SW-Cs. This API can only be used through the RTE and therefore no declaration is exported via Dem.h.	
Available via	Dem.h	

D.7.17 <Module>_DemGetFaultDetectionCounter<ForEvent>

Service Name	<Module>_DemGetFaultDetectionCounter<ForEvent>	
Syntax	Std_ReturnType <Module>_DemGetFaultDetectionCounter<ForEvent> (sint8* FaultDetectionCounter)	
Sync/Async	Synchronous	
Reentrancy	Reentrant	
Parameters (in)	None	
Parameters (inout)	None	
Parameters (out)	FaultDetectionCounter	This parameter receives the fault detection counter information of the requested EventId. If the return value of the function call is other than E_OK this parameter does not contain valid data. -128dec...127dec PASSED...FAILED according to ISO 14229-1
Return value	Std_ReturnType	E_OK: request was successful E_NOT_OK: request failed
Description	Gets the current fault detection counter value. There is one c-callback per event using monitor-internal debouncing, if no port interface is provided by the Dem.	
Available via	Dem_Externals.h	

D.7.18 <Module>_DemInitMonitorFor<EventName>

Service Name	<Module>_DemInitMonitorFor<EventName>	
Syntax	Std_ReturnType <Module>_DemInitMonitorFor<EventName> (Dem_InitMonitorReasonType InitMonitorReason)	





Sync/Async	Synchronous	
Reentrancy	Reentrant	
Parameters (in)	InitMonitorReason	Specific (re-)initialization reason evaluated from the monitor to identify the initialization kind to be performed.
Parameters (inout)	None	
Parameters (out)	None	
Return value	Std_ReturnType	Return value unused - only for compatibility with according RTE operation.
Description	Initiates the diagnostic monitor of a specific event. There is one separate callback per event (if configured), if no port interface is provided by the Dem.	
Available via	Dem_Externals.h	

D.7.19 <Module>_DemTriggerOnMonitorStatus

Service Name	<Module>_DemTriggerOnMonitorStatus	
Syntax	Std_ReturnType <Module>_DemTriggerOnMonitorStatus (void)	
Sync/Async	Synchronous	
Reentrancy	Reentrant	
Parameters (in)	None	
Parameters (inout)	None	
Parameters (out)	None	
Return value	Std_ReturnType	E_OK: this function always returns E_OK for compatibility reasons with RTE
Description	Triggers on changes of the monitor status. Called synchronously in context of event status reporting.	
Available via	Dem_Externals.h	

D.7.20 <Module>_DemClearEventAllowed<ForCondition>

Service Name	<Module>_DemClearEventAllowed<ForCondition>	
Syntax	Std_ReturnType <Module>_DemClearEventAllowed<ForCondition> (boolean* Allowed)	
Sync/Async	Synchronous	
Reentrancy	Reentrant	
Parameters (in)	None	
Parameters (inout)	None	
Parameters (out)	Allowed	True - clearance of event is allowed False - clearance of event is not allowed
Return value	Std_ReturnType	E_OK: Operation was successful E_NOT_OK: Operation failed





Description	Triggers on DTC-deletion, which is not allowed if the out-parameter returns False. There is one separate callback per condition, which can be assigned to one or several events, if no port interface is provided by the Dem. Parameter "Allowed" will be unchanged in case E_NOT_OK is returned.
Available via	Dem_Externals.h

D.7.21 <Module>_DemTriggerOnEventData

Service Name	<Module>_DemTriggerOnEventData	
Syntax	Std_ReturnType <Module>_DemTriggerOnEventData (Dem_EventIdType EventId)	
Sync/Async	Synchronous	
Reentrancy	Reentrant	
Parameters (in)	EventId	Identification of an event by assigned EventId.
Parameters (inout)	None	
Parameters (out)	None	
Return value	Std_ReturnType	E_OK: this function always returns E_OK for compatibility reasons with RTE.
Description	Triggers on changes of the event related data in the event memory.	
Available via	Dem_Externals.h	

D.7.22 <Module>_DemTriggerOnEventUdsStatus

Service Name	<Module>_DemTriggerOnEventUdsStatus	
Syntax	Std_ReturnType <Module>_DemTriggerOnEventUdsStatus (Dem_UdsStatusByteType EventStatusByteOld, Dem_UdsStatusByteType EventStatusByteNew)	
Sync/Async	Synchronous	
Reentrancy	Reentrant	
Parameters (in)	EventStatusByteOld	UDS DTC status byte of event before change (refer to chapter "Status bit support").
	EventStatusByteNew	UDS DTC status byte of event after change (refer to chapter "Status bit support").
Parameters (inout)	None	
Parameters (out)	None	
Return value	Std_ReturnType	E_OK: this function always returns E_OK for compatibility reasons with RTE
Description	Triggers on changes of the UDS DTC status byte.	
Available via	Dem_Externals.h	

D.8 FiM

D.8.1 FiM_GetFunctionPermission

Service Name	FiM_GetFunctionPermission	
Syntax	<pre>Std_ReturnType FiM_GetFunctionPermission (FiM_FunctionIdType FID, boolean* Permission)</pre>	
Service ID [hex]	0x01	
Sync/Async	Synchronous	
Reentrancy	Reentrant	
Parameters (in)	FID	Identification of a functionality by assigned FID. The FunctionId is configured in the FiM. Min.: 1 (0: Indication of no functionality) Max.: Result of configuration of FIDs in FiM (Max is either 255 or 65535)
Parameters (inout)	None	
Parameters (out)	Permission	TRUE: FID has permission to run FALSE: FID has no permission to run, i.e. shall not be executed
Return value	Std_ReturnType	E_OK: The request is accepted E_NOT_OK: The request is not accepted, ie. initialization of FiM not completed
Description	This service reports the permission state to the functionality.	
Available via	FiM.h	

D.8.2 FiM_SetFunctionAvailable

Service Name	FiM_SetFunctionAvailable	
Syntax	<pre>Std_ReturnType FiM_SetFunctionAvailable (FiM_FunctionIdType FID, boolean Availability)</pre>	
Service ID [hex]	0x07	
Sync/Async	Synchronous	
Reentrancy	Reentrant	
Parameters (in)	FID	Identification of a functionality by assigned FID.
	Availability	The permission of the requested FID: TRUE: Function is available. FALSE: Function is not available.
Parameters (inout)	None	
Parameters (out)	None	
Return value	Std_ReturnType	E_OK: The request is accepted E_NOT_OK: Request is not accepted (e.g. invalid FID is given)
Description	This service sets the availability of a function. The function is only available if FiMAvailability Support is configured as True.	
Available via	FiM.h	

E Referenced Service Interfaces

E.1 Os

E.2 NvM

E.2.1 NvM_BlockIdType

Name	NvM_BlockIdType		
Kind	Type		
Derived from	uint16		
Range	0..2 ^(16- NvMDataset SelectionBits) -1	–	–
Description	Identification of a NVRAM block via a unique block identifier. Reserved NVRAM block IDs: 0 -> to derive multi block request results via NvM_GetErrorStatus 1 -> redundant NVRAM block which holds the configuration ID		
Variation	–		
Available via	Rte_NvM_Type.h		

E.2.2 NvM_BlockRequestType

Name	NvM_BlockRequestType		
Kind	Type		
Derived from	uint8		
Range	NVM_READ_BLOCK	0x00	NvM_ReadBlock/ NvM_Read PRAMBlock was performed on the block
	NVM_WRITE_BLOCK	0x01	NvM_WriteBlock/ NvM_Write PRAMBlock was performed on the block
	NVM_RESTORE_BLOCK_DEFAULTS	0x02	NvM_RestoreBlockDefaults/ NvM_RestorePRAMBlockDefaults was performed on the block
	NVM_ERASE_NV_BLOCK	0x03	NvM_EraseNvBlock was performed on the block
	NVM_INVALIDATE_NV_BLOCK	0x04	NvM_InvalidateNvBlock was performed on the block
	NVM_READ_ALL_BLOCK	0x05	NvM_ReadAll has finished processing this block
Description	Identifies the type of request performed on a block when signaled via the callback function		
Variation	–		
Available via	Rte_NvM_Type.h		

E.2.3 NvM_InitBlockRequestType

Name	NvM_InitBlockRequestType		
Kind	Type		
Derived from	uint8		
Range	NVM_INIT_READ_BLOCK	0x00	NvM_ReadBlock/ NvM_ReadPRAMBlock is requested on the block
	NVM_INIT_RESTORE_BLOCK_DEFAULTS	0x01	NvM_RestoreBlockDefaults/ NvM_RestorePRAMBlockDefaults is requested on the block
	NVM_INIT_READ_ALL_BLOCK	0x02	NvM_ReadAll is processing this block
	NVM_INIT_FIRST_INIT_ALL	0x03	NvM_FirstInitAll is processing this block
Description	Identifies the type of request performed on a block when signaled via the callback function		
Variation	–		
Available via	Rte_NvM_Type.h		

E.2.4 NvM_RequestResultType

Name	NvM_RequestResultType		
Kind	Type		
Derived from	uint8		
Range	NVM_REQ_OK	0x00	The last asynchronous request has been finished successfully. This shall be the default value after reset. This status shall have the value 0.
	NVM_REQ_NOT_OK	0x01	The last asynchronous read/write/control request has been finished unsuccessfully.
	NVM_REQ_PENDING	0x02	An asynchronous read/write/control request is currently pending.
	NVM_REQ_INTEGRITY_FAILED	0x03	The result of the last asynchronous request NvM_ReadBlock or NvM_ReadAll is a data integrity failure. Note: In case of NvM_ReadBlock the content of the RAM block has changed but has become invalid. The application is responsible to renew and validate the RAM block content.





	NVM_REQ_BLOCK_SKIPPED	0x04	The referenced block was skipped during execution of NvM_ReadAll or NvM_WriteAll, e.g. Dataset NVRAM blocks (NvM_ReadAll) or NVRAM blocks without a permanently configured RAM block.
	NVM_REQ_NV_INVALIDATED	0x05	The referenced NV block is invalidated.
	NVM_REQ_CANCELED	0x06	The multi block request NvM_WriteAll was canceled by calling NvM_CancelWriteAll. Or Any single block job request (NvM_ReadBlock, NvM_WriteBlock, NvM_EraseNvBlock, NvM_InvalidateNvBlock and NvM_RestoreBlock Defaults) was canceled by calling NvM_CancelJobs.
	NVM_REQ_RESTORED_DEFAULTS	0x08	The referenced NV block had the default values copied to the RAM image.
Description	This is an asynchronous request result returned by the API service NvM_GetErrorStatus. The availability of an asynchronous request result can be additionally signaled via a callback function.		
Variation	–		
Available via	Rte_NvM_Type.h		

E.2.5 NvMService

Name	NvMService		
Comment	–		
IsService	true		
Variation	–		
Possible Errors	0	E_OK	Operation successful
	1	E_NOT_OK	Operation failed

Operation	EraseBlock
Comment	Service to erase a NV block.
Mapped to API	NvM_EraseNvBlock
Variation	<pre>FOR configClass : ECV.subEltList ("NvM/NvMCommon/NvMApiConfigClass"); LET isConfigClass3 = configClass.value() == "NVM_API_CONFIG_CLASS_3"; WHERE isConfigClass3;</pre>
Possible Errors	E_OK E_NOT_OK

Operation	GetDataIndex
Comment	Service for getting the currently set DataIndex of a dataset NVRAM block
Mapped to API	NvM_GetDataIndex





Variation	<pre>FOR configClass : ECV.subEltList("NvM/NvMCommon/NvMApiConfigClass"); LET isConfigClass2 = configClass.value() == "NVM_API_CONFIG_CLASS_2"; WHERE isConfigClass2;</pre>	
Parameters	DataIndex	
	Type	uint8
	Direction	OUT
	Comment	–
	Variation	–
Possible Errors	E_OK E_NOT_OK	

Operation	GetErrorStatus	
Comment	Service to read the block dependent error/status information.	
Mapped to API	NvM_GetErrorStatus	
Variation	–	
Parameters	RequestResult	
	Type	NvM_RequestResultType
	Direction	OUT
	Comment	–
	Variation	–
Possible Errors	E_OK E_NOT_OK	

Operation	InvalidateNvBlock	
Comment	Service to invalidate a NV block.	
Mapped to API	NvM_InvalidateNvBlock	
Variation	<pre>FOR configClass : ECV.subEltList("NvM/NvMCommon/NvMApiConfigClass"); LET isConfigClass3 = configClass.value() == "NVM_API_CONFIG_CLASS_3"; WHERE isConfigClass3;</pre>	
Possible Errors	E_OK E_NOT_OK	

Operation	ReadBlock	
Comment	Service to copy the data of the NV block to its corresponding RAM block.	
Mapped to API	NvM_ReadBlock	
Variation	<pre>FOR configClass : ECV.subEltList("NvM/NvMCommon/NvMApiConfigClass"); LET isConfigClass2 = configClass.value() == "NVM_API_CONFIG_CLASS_2"; isConfigClass3 = configClass.value() == "NVM_API_CONFIG_CLASS_3"; WHERE isConfigClass2 OR isConfigClass3;</pre>	
Parameters	DstPtr	
	Type	VoidPtr
	Direction	IN





	Comment	The parameter "DstPtr" shall be typed by an ImplementationDataType of category DATA_REFERENCE with the pointer target void to pass an address (pointer) to the RAM Block.
	Variation	–
Possible Errors	E_OK E_NOT_OK	

Operation	ReadPRAMBlock
Comment	–
Mapped to API	–
Variation	<pre>FOR configClass : ECV.subEltList ("NvM/NvMCommon/NvMApiConfigClass"); LET isConfigClass2 = configClass.value() == "NVM_API_CONFIG_CLASS_2"; isConfigClass3 = configClass.value() == "NVM_API_CONFIG_CLASS_3"; WHERE isConfigClass2 OR isConfigClass3;</pre>
Possible Errors	E_OK E_NOT_OK

Operation	RestoreBlockDefaults	
Comment	Service to restore the default data to its corresponding RAM block.	
Mapped to API	NvM_RestoreBlockDefaults	
Variation	<pre>FOR configClass : ECV.subEltList ("NvM/NvMCommon/NvMApiConfigClass"); LET isConfigClass2 = configClass.value() == "NVM_API_CONFIG_CLASS_2"; isConfigClass3 = configClass.value() == "NVM_API_CONFIG_CLASS_3"; WHERE isConfigClass2 OR isConfigClass3;</pre>	
Parameters	DstPtr	
	Type	VoidPtr
	Direction	IN
	Comment	The parameter "DstPtr" shall be typed by an ImplementationDataType of category DATA_REFERENCE with the pointer target void to pass an address (pointer) to the RAM Block.
	Variation	–
Possible Errors	E_OK E_NOT_OK	

Operation	RestorePRAMBlockDefaults
Comment	–
Mapped to API	–
Variation	<pre>FOR configClass : ECV.subEltList ("NvM/NvMCommon/NvMApiConfigClass"); LET isConfigClass2 = configClass.value() == "NVM_API_CONFIG_CLASS_2"; isConfigClass3 = configClass.value() == "NVM_API_CONFIG_CLASS_3"; WHERE isConfigClass2 OR isConfigClass3;</pre>
Possible Errors	E_OK E_NOT_OK

Operation	SetDataIndex	
Comment	Service for setting the DataIndex of a dataset NVRAM block.	
Mapped to API	NvM_SetDataIndex	
Variation	<pre> FOR configClass : ECV.subEltList("NvM/NvMCommon/NvMApiConfigClass"); LET isConfigClass2 = configClass.value() == "NVM_API_CONFIG_CLASS_2"; isConfigClass3 = configClass.value() == "NVM_API_CONFIG_CLASS_3"; blockMgmTypes = ECV.subEltList("NvM/NvMBlockDescriptor/ NvMBlockManagementType"); isMgd(mgmtType) = mgmtType.value() == "NVM_BLOCK_DATASET"; datasetMgdCount = blockMgmTypes.filter(isMgd).count(); WHERE (isConfigClass2 OR isConfigClass3) AND (datasetMgdCount > 0); </pre>	
Parameters	DataIndex	
	Type	uint8
	Direction	IN
	Comment	-
	Variation	-
Possible Errors	E_OK E_NOT_OK	

Operation	SetRamBlockStatus	
Comment	Service for setting the RAM block status of an NVRAM block.	
Mapped to API	NvM_SetRamBlockStatus	
Variation	<pre> LET nvMBlockUseSetRamBlockStatus = ECV.subEltList("NvM/ NvMBlockDescriptor/NvMBlockUseSetRamBlockStatus"); useSetRamBlockStatus(useApi) = useApi.value() == true; useSetRamBlockStatusCount = nvMBlockUseSetRamBlockStatus.filter(useSetRamBlockStatus).count(); WHERE (useSetRamBlockStatusCount > 0); </pre>	
Parameters	BlockChanged	
	Type	boolean
	Direction	IN
	Comment	-
	Variation	-
Possible Errors	E_OK E_NOT_OK	

Operation	WriteBlock	
Comment	Service to copy the data of the RAM block to its corresponding NV block.	
Mapped to API	NvM_WriteBlock	
Variation	<pre> FOR configClass : ECV.subEltList("NvM/NvMCommon/NvMApiConfigClass"); LET isConfigClass2 = configClass.value() == "NVM_API_CONFIG_CLASS_2"; isConfigClass3 = configClass.value() == "NVM_API_CONFIG_CLASS_3"; WHERE isConfigClass2 OR isConfigClass3; </pre>	
Parameters	SrcPtr	
	Type	ConstVoidPtr



△

	Direction	IN
	Comment	The parameter "SrcPtr" shall be typed by an ImplementationDataType of category DATA_REFERENCE with the pointer target void to pass an address (pointer) to the RAM Block.
	Variation	–
Possible Errors	E_OK E_NOT_OK	

Operation	WritePRAMBlock
Comment	–
Mapped to API	–
Variation	<pre>FOR configClass : ECV.subEltList ("NvM/NvMCommon/NvMApiConfigClass"); LET isConfigClass2 = configClass.value() == "NVM_API_CONFIG_CLASS_2"; isConfigClass3 = configClass.value() == "NVM_API_CONFIG_CLASS_3"; WHERE isConfigClass2 OR isConfigClass3;</pre>
Possible Errors	E_OK E_NOT_OK

E.2.6 NvMAdmin

Name	NvMAdmin		
Comment	–		
IsService	true		
Variation	–		
Possible Errors	0	E_OK	Operation successful
	1	E_NOT_OK	Operation failed

Operation	SetBlockProtection		
Comment	Service for setting/resetting the write protection for a NV block.		
Mapped to API	NvM_SetBlockProtection		
Variation	<pre>FOR configClass : ECV.subEltList ("NvM/NvMCommon/NvMApiConfigClass"); LET isConfigClass3 = configClass.value() == "NVM_API_CONFIG_CLASS_3"; WHERE isConfigClass3;</pre>		
Parameters	ProtectionEnabled		
	Type	boolean	
	Direction	IN	
	Comment	–	
	Variation	–	
Possible Errors	E_OK E_NOT_OK		

E.2.7 NvMNotifyJobFinished

Name	NvMNotifyJobFinished		
Comment	Callback that is called when a job has finished		
IsService	true		
Variation	–		
Possible Errors	0	E_OK	Operation successful

Operation	JobFinished		
Comment	Callback that gets called if a job has finished		
Mapped to API	–		
Variation	–		
Parameters	BlockRequest		
	Type	NvM_BlockRequestType	
	Direction	IN	
	Comment	–	
	Variation	–	
	JobResult		
	Type	NvM_RequestResultType	
	Direction	IN	
	Variation	–	
Possible Errors	E_OK		

E.2.8 NvMNotifyInitBlock

Name	NvMNotifyInitBlock		
Comment	Callback that is called by the NvM module when default data needs to be restored to the RAM image		
IsService	true		
Variation	–		
Possible Errors	0	E_OK	RAM block content was updated
	1	RTE_E_RAM_UNCHANGED	RAM block content was not changed

Operation	InitBlock		
Comment	This callback is called if the initialization of a block has completed.		
Mapped to API	–		
Variation	–		
Parameters	InitBlockRequest		
	Type	NvM_InitBlockRequestType	
	Direction	IN	
	Comment	–	
	Variation	–	
Possible Errors	–		

E.2.9 NvMMirror

Name	NvMMirror		
Comment	–		
IsService	true		
Variation	–		
Possible Errors	0	E_OK	Operation successful
	1	E_NOT_OK	Operation failed

Operation	ReadRamBlockFromNvM		
Comment	Block specific callback routine which shall be called in order to let the application copy data from NvM module's mirror to RAM block.		
Mapped to API	NvM_ReadRamBlockFromNvm		
Variation	–		
Parameters	SrcPtr		
	Type	ConstVoidPtr	
	Direction	IN	
	Comment	The parameter "SrcPtr" shall be typed by an ImplementationDataType of category DATA_REFERENCE with the pointer target void to pass an address (pointer) to the RAM Block.	
	Variation	–	
Possible Errors	E_OK E_NOT_OK		

Operation	WriteRamBlockToNvM		
Comment	Block specific callback routine which shall be called in order to let the application copy data from RAM block to NvM module's mirror.		
Mapped to API	NvM_WriteRamBlockToNvm		
Variation	–		
Parameters	DstPtr		
	Type	VoidPtr	
	Direction	IN	
	Comment	The parameter "DstPtr" shall be typed by an ImplementationDataType of category DATA_REFERENCE with the pointer target void to pass an address (pointer) to the RAM Block.	
	Variation	–	
Possible Errors	E_OK E_NOT_OK		

E.2.10 PS_{Block}

Name	PS_{Block}		
Kind	ProvidedPort	Interface	NvMService
Description	–		
Port Defined Argument Value(s)	Type	NvM_BlockIdType	





	Value	FOR nvBlockDescriptor : ECV.subEltList("NvM/ NvMBlockDescriptor"); LET Block = nvBlockDescriptor.shortname(); BlockId = nvBlockDescriptor.subElt("NvMNvramBlockIdentifier").value();
Variation		FOR nvBlockDescriptor : ECV.subEltList("NvM/NvMBlockDescriptor"); LET Block = nvBlockDescriptor.shortname(); UsePort = nvBlockDescriptor.subElt("NvMBlockUsePort").value() == true; WHERE UsePort;

E.2.11 PAdmin_{Block}

Name	PAdmin_{Block}		
Kind	ProvidedPort	Interface	NvMAdmin
Description	-		
Port Defined Argument Value(s)	Type	NvM_BlockIdType	
	Value	FOR nvBlockDescriptor : ECV.subEltList("NvM/ NvMBlockDescriptor"); LET Block = nvBlockDescriptor.shortname(); BlockId = nvBlockDescriptor.subElt("NvMNvramBlockIdentifier").value();	
Variation	FOR nvBlockDescriptor : ECV.subEltList("NvM/NvMBlockDescriptor"); LET Block = nvBlockDescriptor.shortname(); UsePort = nvBlockDescriptor.subElt("NvMBlockUsePort").value() == true; WHERE UsePort;		

E.2.12 PNJF_{Block}

Name	PNJF_{Block}		
Kind	RequiredPort	Interface	NvMNotifyJobFinished
Description	-		





Variation	<pre> FOR nvBlockDescriptor : ECV.subEltList("NvM/NvMBlockDescriptor"); LET Block = nvBlockDescriptor.shortname(); UsePort = nvBlockDescriptor.subElt("NvMBlockUsePort"). value() == true; SingleBlockCallbackDef = nvBlockDescriptor.subElt(" NvMSingleBlockCallback").isDefined(); SingleBlockCallbackFncDef = nvBlockDescriptor.subElt(" NvMSingleBlockCallback/NvMSingleBlockCallbackFnc").isDefined(); WHERE UsePort AND SingleBlockCallbackDef AND NOT SingleBlockCallbackFncDef; </pre>
------------------	---

E.2.13 PNIB_{Block}

Name	PNIB_{Block}		
Kind	RequiredPort	Interface	NvMNotifyInitBlock
Description	-		
Variation	<pre> FOR nvBlockDescriptor : ECV.subEltList("NvM/NvMBlockDescriptor"); LET Block = nvBlockDescriptor.shortname(); UsePort = nvBlockDescriptor.subElt("NvMBlockUsePort"). value() == true; InitBlockCallbackDef = nvBlockDescriptor.subElt(" NvMInitBlockCallback").isDefined(); InitBlockCallbackFncDef = nvBlockDescriptor.subElt(" NvMInitBlockCallback/NvMInitBlockCallbackFnc").isDefined(); WHERE UsePort AND InitBlockCallbackDef AND NOT InitBlockCallbackFncDef; </pre>		

E.2.14 PM_{Block}

Name	PM_{Block}		
Kind	RequiredPort	Interface	NvMMirror
Description	-		
Variation	<pre> FOR nvBlockDescriptor : ECV.subEltList("NvM/NvMBlockDescriptor"); LET Block = nvBlockDescriptor.shortname(); UsePort = nvBlockDescriptor.subElt("NvMBlockUsePort").value() == true; UsePortSyncMech = nvBlockDescriptor.subElt("NvMBlockUseSyncMechanism") .value() == true; WHERE UsePort AND UsePortSyncMech; </pre>		

E.3 Dcm

E.3.1 Implementation Data Types

E.3.1.1 Dcm_OpStatusType

Name	Dcm_OpStatusType		
Kind	Type		
Derived from	uint8		
Range	DCM_INITIAL	0x00	Indicates the initial call to the operation
	DCM_PENDING	0x01	Indicates that a pending return has been done on the previous call of the operation
	DCM_CANCEL	0x02	Indicates that the DCM requests to cancel the pending operation
	DCM_FORCE_RCRRP_OK	0x03	Confirm a response pending transmission
Description	–		
Variation	–		
Available via	Rte_Dcm_Type.h		

E.3.1.2 Dcm_ConfirmationStatusType

Name	Dcm_ConfirmationStatusType		
Kind	Type		
Derived from	uint8		
Range	DCM_RES_POS_OK	0x00	–
	DCM_RES_POS_NOT_OK	0x01	–
	DCM_RES_NEG_OK	0x02	–
	DCM_RES_NEG_NOT_OK	0x03	–
Description	–		
Variation	–		
Available via	Rte_Dcm_Type.h		

Name	Dcm_ProtocolType		
Kind	Type		
Derived from	uint8		
Range	DCM_OBD_ON_CAN	0x00	OBD on CAN (ISO15765-4; ISO15031-5)
	DCM_OBD_ON_FLEXRAY	0x01	(OBD on Flexray (Manufacturer specific; ISO15031-5))
	DCM_OBD_ON_IP	0x02	(OBD on Internet Protocol (Manufacturer specific; ISO15031-5))





DCM_UDS_ON_CAN	0x03	UDS on CAN (ISO15765-3; ISO14229-1)
DCM_UDS_ON_FLEXRAY	0x04	UDS on FlexRay (Manufacturer specific; ISO14229-1)
DCM_UDS_ON_IP	0x05	(UDS on Internet Protocol (Manufacturer specific; ISO14229-1))
DCM_ROE_ON_CAN	0x06	Response On Event on CAN
DCM_ROE_ON_FLEXRAY	0x07	Response On Event on FlexRay
DCM_ROE_ON_IP	0x08	(Response on Event on Internet Protocol)
DCM_PERIODICTRANS_ON_CAN	0x09	Periodic Transmission on CAN
DCM_PERIODICTRANS_ON_FLEXRAY	0x0A	Periodic Transmission on FlexRay
DCM_PERIODICTRANS_ON_IP	0x0B	(Periodic Transmission on Internet Protocol)
DCM_NO_ACTIVE_PROTOCOL	0x0C	No protocol has been started
DCM_UDS_ON_LIN	0x0D	UDS on LIN (ISO14229-1; ISO14229-7)
Reserved for further AUTOSAR implementation	0x0E..0xEF	–
DCM_SUPPLIER_1	0xF0	Reserved for SW supplier specific.
DCM_SUPPLIER_2	0xF1	Reserved for SW supplier specific.
DCM_SUPPLIER_3	0xF2	Reserved for SW supplier specific.
DCM_SUPPLIER_4	0xF3	Reserved for SW supplier specific.
DCM_SUPPLIER_5	0xF4	Reserved for SW supplier specific.
DCM_SUPPLIER_6	0xF5	Reserved for SW supplier specific.
DCM_SUPPLIER_7	0xF6	Reserved for SW supplier specific.
DCM_SUPPLIER_8	0xF7	Reserved for SW supplier specific.
DCM_SUPPLIER_9	0xF8	Reserved for SW supplier specific.
DCM_SUPPLIER_10	0xF9	Reserved for SW supplier specific.
DCM_SUPPLIER_11	0xFA	Reserved for SW supplier specific.
DCM_SUPPLIER_12	0xFB	Reserved for SW supplier specific.
DCM_SUPPLIER_13	0xFC	Reserved for SW supplier specific.
DCM_SUPPLIER_14	0xFD	Reserved for SW supplier specific.
DCM_SUPPLIER_15	0xFE	Reserved for SW supplier specific.





Description	Protocol type definition
Variation	–
Available via	Rte_Dcm_Type.h

E.3.1.3 Dcm_NegativeResponseType

Name	Dcm_NegativeResponseType		
Kind	Type		
Derived from	uint8		
Range	DCM_POS_RESP	0x00	PR
	range of values 0x01..0x0F reserved by ISO 14229	0x01..0x0F	ISOSAERESRVD
	DCM_E_GENERALREJECT	0x10	GR
	DCM_E_SERVICENOTSUPPORTED	0x11	SNS
	DCM_E_SUBFUNCTIONNOTSUPPORTED	0x12	SFNS
	DCM_E_INCORRECTMESSAGELENGTHORINVALIDFORMAT	0x13	IMLOIF
	DCM_E_RESPONSETOOLONG	0x14	RTL
	range of values 0x15..0x20 reserved by ISO 14229	0x15..0x20	ISOSAERESRVD
	DCM_E_BUSYREPEATREQUEST	0x21	BRR
	DCM_E_CONDITIONSNOTCORRECT	0x22	CNC
	value 0x23 reserved by ISO 14229	0x23	ISOSAERESRVD
	DCM_E_REQUESTSEQUENCEERROR	0x24	RSE
	DCM_E_NORESPONSEFROMSUBNETCOMPONENT	0x25	NRFSC
	DCM_E_FAILUREPREVENTSEXCUTIONOFREQUESTEDACTION	0x26	FPEORA
	range of values 0x27..0x30 reserved by ISO 14229	0x27..0x30	ISOSAERESRVD
	DCM_E_REQUESTOUTOFRANGE	0x31	ROOR
	value 0x32 reserved by ISO 14229	0x32	ISOSAERESRVD
	DCM_E_SECURITYACCESSDENIED	0x33	SAD
	value 0x34 reserved by ISO 14229	0x34	ISOSAERESRVD
	DCM_E_INVALIDKEY	0x35	IK





DCM_E_EXCEEDNUMBEROFATTEMPTS	0x36	ENOA
DCM_E_REQUIRED-TIMEDELAYNOTEXPIRED	0x37	RTDNE
range of values 0x38..0x4F reserved by ISO 15764	0x38..0x4F	RBEDLSD
range of values 0x50..0x6F reserved by ISO 14229	0x50..0x6F	ISOSAERESRVD
DCM_E_UPLOADDOWN-LOADNOTACCEPTED	0x70	UDNA
DCM_E_TRANSFERDATA-SUSPENDED	0x71	TDS
DCM_E_GENERALPRO-GRAMMINGFAILURE	0x72	GPF
DCM_E_WRONGBLOCK-SEQUENCECOUNTER	0x73	WBSC
range of values 0x74..0x77 reserved by ISO 14229	0x74..0x77	ISOSAERESRVD
range of values 0x79..0x7D reserved by ISO 14229	0x79..0x7D	ISOSAERESRVD
DCM_E_SUBFUNCTION-NOTSUPPORTEDINAC-TIVESESSION	0x7E	SFNSIAS
DCM_E_SERVICE-NOTSUPPORTE-DINACTIVESESSION	0x7F	SNSIAS
value 0x80 reserved by ISO 14229	0x80	ISOSAERESRVD
DCM_E_RPMTOOHIGH	0x81	RPMTH
DCM_E_RPMTOOLOW	0x82	RPMTL
DCM_E_ENGINEISRUNNING	0x83	EIR
DCM_E_ENGINEISNOTRUNNING	0x84	EINR
DCM_E_ENGINE-RUN-TIMETOLOW	0x85	ERTTL
DCM_E_TEMPERATURETOOHIGH	0x86	TEMPH
DCM_E_TEMPERATURETOOLOW	0x87	TEMPTL
DCM_E_VEHCLESPEEDTOOHIGH	0x88	VSTH
DCM_E_VEHCLESPEEDTOOLOW	0x89	VSTL
DCM_E_THROTTLE-PEDALTOOHIGH	0x8A	TPTH
DCM_E_THROTTLE-PEDALTOOLOW	0x8B	TPTL
DCM_E_TRANSMISSION-RANGENOTINNEUTRAL	0x8C	TRNIN
DCM_E_TRANSMISSION-RANGENOTINGEAR	0x8D	TRNIG
value 0x8E reserved by ISO 14229	0x8E	ISOSAERESRVD
DCM_E_BRAKESWITCH-NOTCLOSED	0x8F	BSNC





	DCM_E_SHIFTERLEVER-NOTINPARK	0x90	SLNIP
	DCM_E_TORQUECONVERTERCLUTCHLOCKED	0x91	TCCL
	DCM_E_VOLTAGETOOHIGH	0x92	VTH
	DCM_E_VOLTAGETOLOW	0x93	VTL
	range of values 0x94..0xEF reserved by ISO 14229	0x94..0xEF	RFSCNC
	DCM_E_VMSCNC_0	0xF0	VMSCNC
	DCM_E_VMSCNC_1	0xF1	VMSCNC1
	DCM_E_VMSCNC_2	0xF2	VMSCNC2
	DCM_E_VMSCNC_3	0xF3	VMSCNC3
	DCM_E_VMSCNC_4	0xF4	VMSCNC4
	DCM_E_VMSCNC_5	0xF5	VMSCNC5
	DCM_E_VMSCNC_6	0xF6	VMSCNC6
	DCM_E_VMSCNC_7	0xF7	VMSCNC7
	DCM_E_VMSCNC_8	0xF8	VMSCNC8
	DCM_E_VMSCNC_9	0xF9	VMSCNC9
	DCM_E_VMSCNC_A	0xFA	VMSCNCA
	DCM_E_VMSCNC_B	0xFB	VMSCNCB
	DCM_E_VMSCNC_C	0xFC	VMSCNCC
	DCM_E_VMSCNC_D	0xFD	VMSCNCD
	DCM_E_VMSCNC_E	0xFE	VMSCNCE
	value 0xFF reserved by ISO 14229	0xFF	ISOSAERESRVD
Description	This Table of available Negative Response Codes represents the allowed Response Codes an AUTOSAR SW Component shall return after a function call. For the allowed NRC of the executed Service ID please refer to the specification of the service in ISO14229-1 (UDS) and ISO15031-5 (OBD/CARB) (see chapter 4.2.4 Response code parameter definition Table 12).		
Variation	-		
Available via	Rte_Dcm_Type.h		

E.3.1.4 Dcm_DataElementType_{Data}Type

Name	Dcm_DataElement_{Data}Type	
Kind	Type	
Derived from	Basetype	Variation
	Dcm_DataElement_{Data}_ArrayType	((ecuc(Dcm/?DcmConfigSet/?DcmDsp/?DcmDspData.?DcmDspDataType)) == ([S U]INT[8 16 32] FLOAT)_N) (ecuc(Dcm/?DcmConfigSet/?DcmDsp/?DcmDspPid/?DcmDspPidData/?DcmDspPidService01.?DcmDspPidDataType)) == ([S U]INT[8 16 32] FLOAT)_N))





	Dcm_DataElement_{Data}_PrimitiveType	(({ecuc(Dcm/?DcmConfigSet/?DcmDsp/?DcmDspData.?DcmDspData Type)} == (BOOLEAN [S U]INT[8 16 32] FLOAT)) ({ecuc(Dcm/?DcmConfigSet/?DcmDsp/?DcmDspPid/?DcmDspPidData/?DcmDspPidService01.?DcmDspPidData Type)} == (BOOLEAN [S U]INT[8 16 32] FLOAT)))
	Dcm_DataElement_{Data}_StructuredType	DcmDspDidSignal with at least one DcmDspDidSignalComposite Ref.
Description	Common description for S/R and C/S data elements.	
Variation	(({Dcm/DcmConfigSet/DcmDsp/DcmDspDid/DcmDspDidUsePort == USE_DATA_ELEMENT_SPECIFIC_INTERFACES}) && (({ecuc(Dcm/DcmConfigSet/DcmDsp/DcmDspData/DcmDspDataUsePort)} == USE_DATA_SENDER_RECEIVER) ({ecuc(Dcm/DcmConfigSet/DcmDsp/DcmDspPid/DcmDspPidData/DcmDspPidDataUsePort)} == USE_DATA_SENDER_RECEIVER) ({ecuc(Dcm/DcmConfigSet/DcmDsp/DcmDspPid/DcmDspPidData/DcmDspPidService01/DcmDspPidDataUsePort)} == USE_DATA_SENDER_RECEIVER_AS_SERVICE) ({ecuc(Dcm/DcmConfigSet/DcmDsp/DcmDspData/DcmDspDataUsePort)} == USE_DATA_SENDER_RECEIVER_AS_SERVICE) ({ecuc(Dcm/DcmConfigSet/DcmDsp/DcmDspData.DcmDspDataUsePort)} == USE_DATA_SYNCH_CLIENT_SERVER) ({ecuc(Dcm/DcmConfigSet/DcmDsp/DcmDspData.DcmDspDataUsePort)} == USE_DATA_ASYNC_CLIENT_SERVER) ({ecuc(Dcm/DcmConfigSet/DcmDsp/DcmDspData.DcmDspDataUsePort)} == USE_DATA_ASYNC_CLIENT_SERVER_ERROR) ({ecuc(Dcm/DcmConfigSet/DcmDsp/DcmDspPid/DcmDspPidData/DcmDspPidService01.DcmDspPidDataUsePort)} == USE_DATA_SYNCH_CLIENT_SERVER))) Data = ({ecuc(Dcm/DcmConfigSet/DcmDsp/DcmDspData.SHORT-NAME)}) ({ecuc(Dcm/DcmConfigSet/DcmDsp/DcmDspPid/DcmDspPidData.SHORT-NAME)})	
Available via	Rte_Dcm_Type.h	

E.3.1.5 Dcm_DataElementType_{Data}ArrayType

Name	Dcm_DataElement_{Data}_ArrayType	
Kind	Array	
Element type	Type	Variation
	float32	(({ecuc(Dcm/?DcmConfigSet/?DcmDsp/?DcmDspData.?DcmDspData Type)} == FLOAT_N) ({ecuc(Dcm/?DcmConfigSet/?DcmDsp/?DcmDspPid/?DcmDspPidData/?DcmDspPidService01.?DcmDspPidData Type)} == FLOAT_N))
	sint16	(({ecuc(Dcm/?DcmConfigSet/?DcmDsp/?DcmDspData.?DcmDspData Type)} == SINT16_N) ({ecuc(Dcm/?DcmConfigSet/?DcmDsp/?DcmDspPid/?DcmDspPidData/?DcmDspPidService01.?DcmDspPidData Type)} == SINT16_N))
	sint32	(({ecuc(Dcm/?DcmConfigSet/?DcmDsp/?DcmDspData.?DcmDspData Type)} == SINT32_N) ({ecuc(Dcm/?DcmConfigSet/?DcmDsp/?DcmDspPid/?DcmDspPidData/?DcmDspPidService01.?DcmDspPidData Type)} == SINT32_N))
	sint8	(({ecuc(Dcm/?DcmConfigSet/?DcmDsp/?DcmDspData.?DcmDspData Type)} == SINT8_N) ({ecuc(Dcm/?DcmConfigSet/?DcmDsp/?DcmDspPid/?DcmDspPidData/?DcmDspPidService01.?DcmDspPidData Type)} == SINT8_N))
	uint16	(({ecuc(Dcm/?DcmConfigSet/?DcmDsp/?DcmDspData.?DcmDspData Type)} == UINT16_N) ({ecuc(Dcm/?DcmConfigSet/?DcmDsp/?DcmDspPid/?DcmDspPidData/?DcmDspPidService01.?DcmDspPidData Type)} == UINT16_N))





	uint32	{{{ecuc(Dcm/?DcmConfigSet/?DcmDsp/?DcmDspData.?DcmDspDataType) == UINT32_N} {{{ecuc(Dcm/?DcmConfigSet/?DcmDsp/?DcmDspPid/?DcmDspPidData/?DcmDspPidService01.?DcmDspPidDataType) == UINT32_N}}}}
	uint8	{{{ecuc(Dcm/?DcmConfigSet/?DcmDsp/?DcmDspData.?DcmDspDataType) == UINT8_N} {{{ecuc(Dcm/?DcmConfigSet/?DcmDsp/?DcmDspPid/?DcmDspPidData/?DcmDspPidService01.?DcmDspPidDataType) == UINT8_N}}}}
Size	-	
Description	-	
Variation	{{{{ecuc(Dcm/DcmConfigSet/DcmDsp/DcmDspData.DcmDspDataType) == ([S U]INT[8 16 32] FLOAT)_N} {{{ecuc(Dcm/DcmConfigSet/DcmDsp/DcmDspPid/DcmDspPidData/DcmDspPidService01.DcmDspPidDataType) == ([S U]INT[8 16 32] FLOAT)_N}}}} && {{{Dcm/DcmConfigSet/DcmDsp/DcmDspDid/DcmDspDidUsePort == USE_DATA_ELEMENT_SPECIFIC_INTERFACES}}}} && {{{{ecuc(Dcm/DcmConfigSet/DcmDsp/DcmDspData/DcmDspDataUsePort) == USE_DATA_SENDER_RECEIVER} {{{ecuc(Dcm/DcmConfigSet/DcmDsp/DcmDspPid/DcmDspPidData/DcmDspPidService01/DcmDspPidDataUsePort) == USE_DATA_SENDER_RECEIVER} {{{ecuc(Dcm/DcmConfigSet/DcmDsp/DcmDspPid/DcmDspPidData/DcmDspPidService01/DcmDspPidDataUsePort) == USE_DATA_SENDER_RECEIVER_AS_SERVICE} {{{ecuc(Dcm/DcmConfigSet/DcmDsp/DcmDspData/DcmDspDataUsePort) == USE_DATA_SENDER_RECEIVER_AS_SERVICE} {{{ecuc(Dcm/DcmConfigSet/DcmDsp/DcmDspData.DcmDspDataUsePort) == USE_DATA_SYNCH_CLIENT_SERVER} {{{ecuc(Dcm/DcmConfigSet/DcmDsp/DcmDspData.DcmDspDataUsePort) == USE_DATA_ASYNCH_CLIENT_SERVER} {{{ecuc(Dcm/DcmConfigSet/DcmDsp/DcmDspData.DcmDspDataUsePort) == USE_DATA_ASYNCH_CLIENT_SERVER_ERROR} {{{ecuc(Dcm/DcmConfigSet/DcmDsp/DcmDspPid/DcmDspPidData/DcmDspPidService01.DcmDspPidDataUsePort) == USE_DATA_SYNCH_CLIENT_SERVER}}}}}}}}}} Data = {{{ecuc(Dcm/DcmConfigSet/DcmDsp/DcmDspData.SHORT-NAME)}}} {{{ecuc(Dcm/DcmConfigSet/DcmDsp/DcmDspPid/DcmDspPidData.SHORT-NAME)}}}	
Available via	Rte_Dcm_Type.h	

E.3.1.6 Dcm_DataElement_{Data}PrimitiveType

Name	Dcm_DataElement_{Data}_PrimitiveType	
Kind	Type	
Derived from	Basetype	Variation
	boolean	{{{ecuc(Dcm/?DcmConfigSet/?DcmDsp/?DcmDspData.?DcmDspDataType) == BOOLEAN} {{{ecuc(Dcm/?DcmConfigSet/?DcmDsp/?DcmDspPid/?DcmDspPidData/?DcmDspPidService01.?DcmDspPidDataType) == BOOLEAN}}}}
	float32	{{{ecuc(Dcm/?DcmConfigSet/?DcmDsp/?DcmDspData.?DcmDspDataType) == FLOAT} {{{ecuc(Dcm/?DcmConfigSet/?DcmDsp/?DcmDspPid/?DcmDspPidData/?DcmDspPidService01.?DcmDspPidDataType) == FLOAT}}}}
	sint16	{{{ecuc(Dcm/?DcmConfigSet/?DcmDsp/?DcmDspData.?DcmDspDataType) == SINT16} {{{ecuc(Dcm/?DcmConfigSet/?DcmDsp/?DcmDspPid/?DcmDspPidData/?DcmDspPidService01.?DcmDspPidDataType) == SINT16}}}}
	sint32	{{{ecuc(Dcm/?DcmConfigSet/?DcmDsp/?DcmDspData.?DcmDspDataType) == SINT32} {{{ecuc(Dcm/?DcmConfigSet/?DcmDsp/?DcmDspPid/?DcmDspPidData/?DcmDspPidService01.?DcmDspPidDataType) == SINT32}}}}





	sint8	(({ecuc(Dcm/?DcmConfigSet/?DcmDsp/?DcmDspData.?DcmDspData Type)} == SINT8) ({ecuc(Dcm/?DcmConfigSet/?DcmDsp/?DcmDspPid/?DcmDspPidData/?DcmDspPidService01.?DcmDspPidData Type)} == SINT8))
	uint16	(({ecuc(Dcm/?DcmConfigSet/?DcmDsp/?DcmDspData.?DcmDspData Type)} == UINT16) ({ecuc(Dcm/?DcmConfigSet/?DcmDsp/?DcmDspPid/?DcmDspPidData/?DcmDspPidService01.?DcmDspPidData Type)} == UINT16))
	uint32	(({ecuc(Dcm/?DcmConfigSet/?DcmDsp/?DcmDspData.?DcmDspData Type)} == UINT32) ({ecuc(Dcm/?DcmConfigSet/?DcmDsp/?DcmDspPid/?DcmDspPidData/?DcmDspPidService01.?DcmDspPidData Type)} == UINT32))
	uint8	(({ecuc(Dcm/?DcmConfigSet/?DcmDsp/?DcmDspData.?DcmDspData Type)} == UINT8) ({ecuc(Dcm/?DcmConfigSet/?DcmDsp/?DcmDspPid/?DcmDspPidData/?DcmDspPidService01.?DcmDspPidData Type)} == UINT8))
Description	-	
Variation	((({ecuc(Dcm/DcmConfigSet/DcmDsp/DcmDspData.DcmDspData Type)} == (BOOLEAN [S U]INT[8 16 32]FLOAT)) ({ecuc(Dcm/DcmConfigSet/DcmDsp/DcmDspPid/DcmDspPidData/DcmDspPidService01.DcmDspPidData Type)} == (BOOLEAN [S U]INT[8 16 32]FLOAT))) && ({Dcm/DcmConfigSet/DcmDsp/DcmDspDid/DcmDspDidUsePort == USE_DATA_ELEMENT_SPECIFIC_INTERFACES}) && ({ecuc(Dcm/DcmConfigSet/DcmDsp/DcmDspData/DcmDspDataUsePort)} == USE_DATA_SENDER_RECEIVER) ({ecuc(Dcm/DcmConfigSet/DcmDsp/DcmDspPid/DcmDspPidData/DcmDspPidService01/DcmDspPidDataUsePort)} == USE_DATA_SENDER_RECEIVER) ({ecuc(Dcm/DcmConfigSet/DcmDsp/DcmDspPid/DcmDspPidData/DcmDspPidService01/DcmDspPidDataUsePort)} == USE_DATA_SENDER_RECEIVER_AS_SERVICE) ({ecuc(Dcm/DcmConfigSet/DcmDsp/DcmDspData/DcmDspDataUsePort)} == USE_DATA_SENDER_RECEIVER_AS_SERVICE) ({ecuc(Dcm/DcmConfigSet/DcmDsp/DcmDspData.DcmDspDataUsePort)} == USE_DATA_SYNCH_CLIENT_SERVER) ({ecuc(Dcm/DcmConfigSet/DcmDsp/DcmDspData.DcmDspDataUsePort)} == USE_DATA_ASYNCH_CLIENT_SERVER) ({ecuc(Dcm/DcmConfigSet/DcmDsp/DcmDspData.DcmDspDataUsePort)} == USE_DATA_ASYNCH_CLIENT_SERVER_ERROR) ({ecuc(Dcm/DcmConfigSet/DcmDsp/DcmDspPid/DcmDspPidData/DcmDspPidService01.DcmDspPidDataUsePort)} == USE_DATA_SYNCH_CLIENT_SERVER))) Data = ({ecuc(Dcm/DcmConfigSet/DcmDsp/DcmDspData.SHORT-NAME)}) ({ecuc(Dcm/DcmConfigSet/DcmDsp/DcmDspPid/DcmDspPidData.SHORT-NAME)})	
Available via	Rte_Dcm_Type.h	

E.3.1.7 Dcm_DataArrayTypeUint8_{Data}Type

Name	Dcm_DataArrayTypeUint8_{Data}Type		
Kind	Array	Element type	uint8
Size	((({ecuc(Dcm/DcmConfigSet/DcmDsp/DcmDspData.DcmDspDataByteSize)}) ({ecuc(Dcm/DcmConfigSet/DcmDsp/DcmDspPid/DcmDspPidData.DcmDspPidDataByteSize)})) Elements		
Description	-		
Variation	(({ecuc(Dcm/DcmConfigSet/DcmDsp/DcmDspDid/DcmDspDidUsePort)} == USE_DATA_ELEMENT_SPECIFIC_INTERFACES) && ({ecuc(Dcm/DcmConfigSet/DcmDsp/DcmDspData.DcmDspData Type)} == UINT8_N) ({ecuc(Dcm/DcmConfigSet/DcmDsp/DcmDspData.DcmDspData Type)} == UINT8_DYN) ({ecuc(Dcm/DcmConfigSet/DcmDsp/DcmDspPid/DcmDspPidData/DcmDspPidService01.DcmDspPidData Type)} == UINT8_N)) Data = ({ecuc(Dcm/DcmConfigSet/DcmDsp/DcmDspData.SHORT-NAME)}) ({ecuc(Dcm/DcmConfigSet/DcmDsp/DcmDspPid/DcmDspPidData.SHORT-NAME)})		
Available via	Rte_Dcm_Type.h		

E.3.1.8 {DID}_Struct_DataType

This data type has a different modeling as other data types. The {DID}_Struct_DataType datatype is modeled as prosa text only. At the time this specification was created there are no means to visualize this datatype with existing AUTOSAR tooling as table as all the other data types. Still AUTOSAR allows modeling such data types. Simply that they cannot be shown here as table.

Name	{DID}_Struct_DataType
Kind	Structure
Description	The elements of this structure data type is a composition of all DcmDspDataElement of the DcmDspDid. Example: A DID with the 3 data elements uint32 data1, sint8 data2 and sint16 data 3, has a structure definition of struct { uint32 data1, sint8 data2, sint16 data 3}.
Variation	((ecuc(Dcm/DcmConfigSet/DcmDsp/DcmDspDid/DcmDspDidUsePort)) == ((USE_ATOMIC_SENDER_RECEIVER_INTERFACE USE_ATOMIC_SENDER_RECEIVER_INTERFACE_AS_SERVICE) USE_ATOMIC_NV_DATA_INTERFACE)) DID = ({ecuc(Dcm/DcmConfigSet/DcmDsp/DcmDspDid.SHORT-NAME)})
Available via	Rte_Dcm_Type.h

E.3.1.9 Dcm_RangeArray_{Range}Type

Name	Dcm_RangeArray_{Range}Type		
Kind	Array	Element type	uint8
Size	{ecuc(Dcm/DcmConfigSet/DcmDsp/DcmDspDidRangeMaxDataLength)} Elements		
Description	–		
Variation	{ecuc(Dcm/DcmConfigSet/DcmDsp/DcmDspDidRange.DcmDspDidRangeUsePort)} == TRUE Range = {ecuc(Dcm/DcmConfigSet/DcmDsp/DcmDspDidRange.SHORT-NAME)}		
Available via	Rte_Dcm_Type.h		

E.3.1.10 Dcm_ScalingInfoArray_{Data}Type

Name	Dcm_ScalingInfoArray_{Data}Type		
Kind	Array	Element type	uint8
Size	{ecuc(Dcm/DcmConfigSet/DcmDsp/DcmDspDataInfo.DcmDspDataScalingInfoSize)} Elements		
Description	–		
Variation	(((ecuc(Dcm/DcmConfigSet/DcmDsp/DcmDspData.DcmDspDataUsePort)) == USE_DATA_ASYNC_CLIENT_SERVER) ((ecuc(Dcm/DcmConfigSet/DcmDsp/DcmDspData.DcmDspDataUsePort)) == USE_DATA_SYNC_CLIENT_SERVER) ((ecuc(Dcm/DcmConfigSet/DcmDsp/DcmDspData.DcmDspDataUsePort)) == USE_DATA_ASYNC_CLIENT_SERVER_ERROR)) && ((ecuc(Dcm/DcmConfigSet/DcmDsp/DcmDspData->DcmDspDataInfoRef.DcmDspDataScalingInfoSize)) != NULL) Data = {ecuc(Dcm/DcmConfigSet/DcmDsp/DcmDspData.SHORT-NAME)}		
Available via	Rte_Dcm_Type.h		

E.3.1.11 Dcm_RequestDataOut_{Routine}_{Signal}PrimitivType

Name	Dcm_RequestDataOut_{Routine}_{Signal}PrimitivType	
Kind	Type	
Derived from	Basetype	Variation
	float32	{ecuc(Dcm/DcmConfigSet/DcmDsp/DcmDspRoutine/DcmDspRequestRoutineResults/DcmDspRequestRoutineResultsOut/DcmDspRequestRoutineResultsOutSignal.DcmDspRoutineSignalType)} == FLOAT
	sint16	{ecuc(Dcm/DcmConfigSet/DcmDsp/DcmDspRoutine/DcmDspRequestRoutineResults/DcmDspRequestRoutineResultsOut/DcmDspRequestRoutineResultsOutSignal.DcmDspRoutineSignalType)} == SINT16
	sint32	{ecuc(Dcm/DcmConfigSet/DcmDsp/DcmDspRoutine/DcmDspRequestRoutineResults/DcmDspRequestRoutineResultsOut/DcmDspRequestRoutineResultsOutSignal.DcmDspRoutineSignalType)} == SINT32
	sint8	{ecuc(Dcm/DcmConfigSet/DcmDsp/DcmDspRoutine/DcmDspRequestRoutineResults/DcmDspRequestRoutineResultsOut/DcmDspRequestRoutineResultsOutSignal.DcmDspRoutineSignalType)} == SINT8
	uint16	{ecuc(Dcm/DcmConfigSet/DcmDsp/DcmDspRoutine/DcmDspRequestRoutineResults/DcmDspRequestRoutineResultsOut/DcmDspRequestRoutineResultsOutSignal.DcmDspRoutineSignalType)} == UINT16
	uint32	{ecuc(Dcm/DcmConfigSet/DcmDsp/DcmDspRoutine/DcmDspRequestRoutineResults/DcmDspRequestRoutineResultsOut/DcmDspRequestRoutineResultsOutSignal.DcmDspRoutineSignalType)} == UINT32
	uint8	{ecuc(Dcm/DcmConfigSet/DcmDsp/DcmDspRoutine/DcmDspRequestRoutineResults/DcmDspRequestRoutineResultsOut/DcmDspRequestRoutineResultsOutSignal.DcmDspRoutineSignalType)} == UINT8
Description	–	
Variation	({ecuc(Dcm/DcmConfigSet/DcmDsp/DcmDspRoutine/DcmDspRequestRoutineResults/DcmDspRequestRoutineResultsOut/DcmDspRequestRoutineResultsOutSignal.DcmDspRoutineSignalType)} == [U S]INT[8 16 32]FLOAT) && ({ecuc(Dcm/DcmConfigSet/DcmDsp/DcmDspRoutine/DcmDspRoutineUsePort)} == TRUE) Signal = {ecuc(Dcm/DcmConfigSet/DcmDsp/DcmDspRoutine/DcmDspRequestRoutineResults/DcmDspRequestRoutineResultsOut/DcmDspRequestRoutineResultsOutSignal.SHORT-NAME)} Routine = {ecuc(Dcm/DcmConfigSet/DcmDsp/DcmDspRoutine.SHORT-NAME)}	
Available via	Rte_Dcm_Type.h	

E.3.1.12 Dcm_RequestDataIn_{Routine}_{Signal}PrimitiveType

Name	Dcm_RequestDataIn_{Routine}_{Signal}PrimitiveType	
Kind	Type	
Derived from	Basetype	Variation





	float32	{ecuc(Dcm/DcmConfigSet/DcmDsp/DcmDspRoutine/DcmDspRequestRoutineResults/DcmDspRequestRoutineResultsIn/DcmDspRequestRoutineResultsInSignal.DcmDspRoutineSignalType)} == FLOAT
	sint16	{ecuc(Dcm/DcmConfigSet/DcmDsp/DcmDspRoutine/DcmDspRequestRoutineResults/DcmDspRequestRoutineResultsIn/DcmDspRequestRoutineResultsInSignal.DcmDspRoutineSignalType)} == SINT16
	sint32	{ecuc(Dcm/DcmConfigSet/DcmDsp/DcmDspRoutine/DcmDspRequestRoutineResults/DcmDspRequestRoutineResultsIn/DcmDspRequestRoutineResultsInSignal.DcmDspRoutineSignalType)} == SINT32
	sint8	{ecuc(Dcm/DcmConfigSet/DcmDsp/DcmDspRoutine/DcmDspRequestRoutineResults/DcmDspRequestRoutineResultsIn/DcmDspRequestRoutineResultsInSignal.DcmDspRoutineSignalType)} == SINT8
	uint16	{ecuc(Dcm/DcmConfigSet/DcmDsp/DcmDspRoutine/DcmDspRequestRoutineResults/DcmDspRequestRoutineResultsIn/DcmDspRequestRoutineResultsInSignal.DcmDspRoutineSignalType)} == UINT16
	uint32	{ecuc(Dcm/DcmConfigSet/DcmDsp/DcmDspRoutine/DcmDspRequestRoutineResults/DcmDspRequestRoutineResultsIn/DcmDspRequestRoutineResultsInSignal.DcmDspRoutineSignalType)} == UINT32
	uint8	{ecuc(Dcm/DcmConfigSet/DcmDsp/DcmDspRoutine/DcmDspRequestRoutineResults/DcmDspRequestRoutineResultsIn/DcmDspRequestRoutineResultsInSignal.DcmDspRoutineSignalType)} == UINT8
Description	-	
Variation	({ecuc(Dcm/DcmConfigSet/DcmDsp/DcmDspRoutine/DcmDspRequestRoutineResults/DcmDspRequestRoutineResultsIn/DcmDspRequestRoutineResultsInSignal.DcmDspRoutineSignalType)} == [U S]INT[8 16 32]FLOAT) && ({ecuc(Dcm/DcmConfigSet/DcmDsp/DcmDspRoutine/DcmDspRoutineUsePort)} == TRUE) Signal = {ecuc(Dcm/DcmConfigSet/DcmDsp/DcmDspRoutine/DcmDspRequestRoutineResults/DcmDspRequestRoutineResultsIn/DcmDspRequestRoutineResultsInSignal.SHORT-NAME)} Routine = {ecuc(Dcm/DcmConfigSet/DcmDsp/DcmDspRoutine.SHORT-NAME)}	
Available via	Rte_Dcm_Type.h	

E.3.1.13 Dcm_RequestDataOut_{Routine}_{Signal}Type

Name	Dcm_RequestDataOut_{Routine}_{Signal}Type	
Kind	Type	
Derived from	Basetype	Variation
	Dcm_RequestDataOut_{Routine}_{Signal}PrimitiveType	({ecuc(Dcm/DcmConfigSet/DcmDsp/DcmDspRoutine/DcmDspRequestRoutineResults/DcmDspRequestRoutineResultsOut/DcmDspRequestRoutineResultsOutSignal.DcmDspRoutineSignalType)} == ([U S]INT[8 16 32]FLOAT))
	Dcm_RequestDataOut_{Routine}_{Signal}ArrayType	({ecuc(Dcm/DcmConfigSet/DcmDsp/DcmDspRoutine/DcmDspRequestRoutineResults/DcmDspRequestRoutineResultsOut/DcmDspRequestRoutineResultsOutSignal.DcmDspRoutineSignalType)} == ([U S]INT[8 16 32]FLOAT)_N)





	Dcm_RequestDataOut_{Routine}_{Signal}Structured Type	DcmDspRequestRoutineResultsOutSignal with at least one DcmDspRequestRoutineResultsOutSignalCompositeSignalRef.
Description	–	
Variation	({ecuc(Dcm/DcmConfigSet/DcmDsp/DcmDspRoutine/DcmDspRoutineUsePort)} == TRUE) Signal = {ecuc(Dcm/DcmConfigSet/DcmDsp/DcmDspRoutine/DcmDspRequestRoutineResults/DcmDspRequestRoutineResultsOut/DcmDspRequestRoutineResultsOutSignal.SHORT-NAME)} Routine = {ecuc(Dcm/DcmConfigSet/DcmDsp/DcmDspRoutine.SHORT-NAME)}	
Available via	Rte_Dcm_Type.h	

E.3.1.14 Dcm_RequestDataIn_{Routine}_{Signal}Type

Name	Dcm_RequestDataIn_{Routine}_{Signal}Type	
Kind	Type	
Derived from	Basetype	Variation
	Dcm_RequestDataIn_{Routine}_{Signal}Primitive Type	({ecuc(Dcm/DcmConfigSet/DcmDsp/DcmDspRoutine/DcmDspRequestRoutineResults/DcmDspRequestRoutineResultsIn/DcmDspRequestRoutineResultsInSignal.DcmDspRoutineSignalType)} == ([U S]INT[8 16 32] FLOAT))
	Dcm_RequestDataIn_{Routine}_{Signal}ArrayType	({ecuc(Dcm/DcmConfigSet/DcmDsp/DcmDspRoutine/DcmDspRequestRoutineResults/DcmDspRequestRoutineResultsIn/DcmDspRequestRoutineResultsInSignal.DcmDspRoutineSignalType)} == ([U S]INT[8 16 32] FLOAT)_N)
	Dcm_RequestDataIn_{Routine}_{Signal}Structured Type	DcmDspRequestRoutineResultsInSignal with at least one DcmDspRequestRoutineResultsInSignalCompositeSignalRef.
Description	–	
Variation	({ecuc(Dcm/DcmConfigSet/DcmDsp/DcmDspRoutine/DcmDspRoutineUsePort)} == TRUE) Signal = {ecuc(Dcm/DcmConfigSet/DcmDsp/DcmDspRoutine/DcmDspRequestRoutineResults/DcmDspRequestRoutineResultsIn/DcmDspRequestRoutineResultsInSignal.SHORT-NAME)} Routine = {ecuc(Dcm/DcmConfigSet/DcmDsp/DcmDspRoutine.SHORT-NAME)}	
Available via	Rte_Dcm_Type.h	

E.3.1.15 Dcm_RequestDataOut_{Routine}_{Signal}ArrayType

Name	Dcm_RequestDataOut_{Routine}_{Signal}ArrayType	
Kind	Array	
Element type	Type	Variation
	float32	({ecuc(Dcm/DcmConfigSet/DcmDsp/DcmDspRoutine/DcmDspRequestRoutineResults/DcmDspRequestRoutineResultsOut/DcmDspRequestRoutineResultsOutSignal.DcmDspRoutineSignalType)} == FLOAT_N)
	sint16	({ecuc(Dcm/DcmConfigSet/DcmDsp/DcmDspRoutine/DcmDspRequestRoutineResults/DcmDspRequestRoutineResultsOut/DcmDspRequestRoutineResultsOutSignal.DcmDspRoutineSignalType)} == SINT16_N)





	sint32	{{ecuc(Dcm/DcmConfigSet/DcmDsp/DcmDspRoutine/DcmDspRequestRoutineResults/DcmDspRequestRoutineResultsOut/DcmDspRequestRoutineResultsOutSignal.DcmDspRoutineSignalType)} == SINT32_N}
	sint8	{{ecuc(Dcm/DcmConfigSet/DcmDsp/DcmDspRoutine/DcmDspRequestRoutineResults/DcmDspRequestRoutineResultsOut/DcmDspRequestRoutineResultsOutSignal.DcmDspRoutineSignalType)} == SINT8_N}
	uint16	{{ecuc(Dcm/DcmConfigSet/DcmDsp/DcmDspRoutine/DcmDspRequestRoutineResults/DcmDspRequestRoutineResultsOut/DcmDspRequestRoutineResultsOutSignal.DcmDspRoutineSignalType)} == UINT16_N}
	uint32	{{ecuc(Dcm/DcmConfigSet/DcmDsp/DcmDspRoutine/DcmDspRequestRoutineResults/DcmDspRequestRoutineResultsOut/DcmDspRequestRoutineResultsOutSignal.DcmDspRoutineSignalType)} == UINT32_N}
	uint8	{{ecuc(Dcm/DcmConfigSet/DcmDsp/DcmDspRoutine/DcmDspRequestRoutineResults/DcmDspRequestRoutineResultsOut/DcmDspRequestRoutineResultsOutSignal.DcmDspRoutineSignalType)} == UINT8_N}
Size	{ecuc(Dcm/DcmConfigSet/DcmDsp/DcmDspRoutine/DcmDspRequestRoutineResults/DcmDspRequestRoutineResultsOut/DcmDspRequestRoutineResultsOutSignal.DcmDspRoutineParameterSize)} Elements	
Description	–	
Variation	{{ecuc(Dcm/DcmConfigSet/DcmDsp/DcmDspRoutine/DcmDspRequestRoutineResults/DcmDspRequestRoutineResultsOut/DcmDspRequestRoutineResultsOutSignal.DcmDspRoutineSignalType)} == ([U S]INT[8 16 32] FLOAT)_N} && {{ecuc(Dcm/DcmConfigSet/DcmDsp/DcmDspRoutine/DcmDspRoutineUsePort)} == TRUE} Signal = {ecuc(Dcm/DcmConfigSet/DcmDsp/DcmDspRoutine/DcmDspRequestRoutineResults/DcmDspRequestRoutineResultsOut/DcmDspRequestRoutineResultsOutSignal.SHORT-NAME)} Routine = {ecuc(Dcm/DcmConfigSet/DcmDsp/DcmDspRoutine.SHORT-NAME)}	
Available via	Rte_Dcm_Type.h	

E.3.1.16 Dcm_RequestDataIn_{Routine}_{Signal}ArrayType

Name	Dcm_RequestDataIn_{Routine}_{Signal}ArrayType	
Kind	Array	
Element type	Type	Variation
	float32	{ecuc(Dcm/DcmConfigSet/DcmDsp/DcmDspRoutine/DcmDspRequestRoutineResults/DcmDspRequestRoutineResultsIn/DcmDspRequestRoutineResultsInSignal.DcmDspRoutineSignalType)} == FLOAT_N
	sint16	{ecuc(Dcm/DcmConfigSet/DcmDsp/DcmDspRoutine/DcmDspRequestRoutineResults/DcmDspRequestRoutineResultsIn/DcmDspRequestRoutineResultsInSignal.DcmDspRoutineSignalType)} == SINT16_N
	sint32	{ecuc(Dcm/DcmConfigSet/DcmDsp/DcmDspRoutine/DcmDspRequestRoutineResults/DcmDspRequestRoutineResultsIn/DcmDspRequestRoutineResultsInSignal.DcmDspRoutineSignalType)} == SINT32_N
	sint8	{ecuc(Dcm/DcmConfigSet/DcmDsp/DcmDspRoutine/DcmDspRequestRoutineResults/DcmDspRequestRoutineResultsIn/DcmDspRequestRoutineResultsInSignal.DcmDspRoutineSignalType)} == SINT8_N
	uint16	{ecuc(Dcm/DcmConfigSet/DcmDsp/DcmDspRoutine/DcmDspRequestRoutineResults/DcmDspRequestRoutineResultsIn/DcmDspRequestRoutineResultsInSignal.DcmDspRoutineSignalType)} == UINT16_N





	uint32	{ecuc(Dcm/DcmConfigSet/DcmDsp/DcmDspRoutine/DcmDspRequestRoutineResults/DcmDspRequestRoutineResultsIn/DcmDspRequestRoutineResultsInSignal.DcmDspRoutineSignalType)} == UINT32_N
	uint8	{ecuc(Dcm/DcmConfigSet/DcmDsp/DcmDspRoutine/DcmDspRequestRoutineResults/DcmDspRequestRoutineResultsIn/DcmDspRequestRoutineResultsInSignal.DcmDspRoutineSignalType)} == UINT8_N
Size	{ecuc(Dcm/DcmConfigSet/DcmDsp/DcmDspRoutine/DcmDspRequestRoutineResults/DcmDspRequestRoutineResultsIn/DcmDspRequestRoutineResultsInSignal.DcmDspRoutineParameterSize)} Elements	
Description	-	
Variation	((ecuc(Dcm/DcmConfigSet/DcmDsp/DcmDspRoutine/DcmDspRequestRoutineResults/DcmDspRequestRoutineResultsIn/DcmDspRequestRoutineResultsInSignal.DcmDspRoutineSignalType)} == ([U S INT[8 16 32] FLOAT)_N) && {ecuc(Dcm/DcmConfigSet/DcmDsp/DcmDspRoutine/DcmDspRoutineUsePort)} == TRUE) Signal = {ecuc(Dcm/DcmConfigSet/DcmDsp/DcmDspRoutine/DcmDspRequestRoutineResults/DcmDspRequestRoutineResultsIn/DcmDspRequestRoutineResultsInSignal.SHORT-NAME)} Routine = {ecuc(Dcm/DcmConfigSet/DcmDsp/DcmDspRoutine.SHORT-NAME)}	
Available via	Rte_Dcm_Type.h	

E.3.1.17 Dcm_RequestFlexibleOutArrayData_{Routine}_{Signal}Type

Name	Dcm_RequestFlexibleOutArrayData_{Routine}_{Signal}Type		
Kind	Array	Element type	uint8
Size	{(ecuc(Dcm/DcmConfigSet/DcmDsp/DcmDspRoutine/DcmDspRequestRoutineResults/DcmDspRequestRoutineResultsOut/DcmDspRequestRoutineResultsOutSignal.DcmDspRoutineParameterSize)} Elements		
Description	-		
Variation	((ecuc(Dcm/DcmConfigSet/DcmDsp/DcmDspRoutine/DcmDspRequestRoutineResults/DcmDspRequestRoutineResultsOut/DcmDspRequestRoutineResultsOutSignal.DcmDspRoutineSignalType)} == VARIABLE_LENGTH) && {ecuc(Dcm/DcmConfigSet/DcmDsp/DcmDspRoutine/DcmDspRoutineUsePort)} == TRUE) Signal = {ecuc(Dcm/DcmConfigSet/DcmDsp/DcmDspRoutine/DcmDspRequestRoutineResults/DcmDspRequestRoutineResultsOut/DcmDspRequestRoutineResultsOutSignal.SHORT-NAME)} Routine = {ecuc(Dcm/DcmConfigSet/DcmDsp/DcmDspRoutine.SHORT-NAME)}		
Available via	Rte_Dcm_Type.h		

E.3.1.18 Dcm_RequestFlexibleInArrayData_{Routine}_{Signal}Type

Name	Dcm_RequestFlexibleInArrayData_{Routine}_{Signal}Type		
Kind	Array	Element type	uint8
Size	{(ecuc(Dcm/DcmConfigSet/DcmDsp/DcmDspRoutine/DcmDspRequestRoutineResults/DcmDspRequestRoutineResultsIn/DcmDspRequestRoutineResultsInSignal.DcmDspRoutineParameterSize)} Elements		
Description	-		





Variation	{ecuc(Dcm/DcmConfigSet/DcmDsp/DcmDspRoutine/DcmDspRequestRoutineResults/DcmDspRequestRoutineResultsIn/DcmDspRequestRoutineResultsInSignal.DcmDspRoutineSignalType)} == VARIABLE_LENGTH) && ({ecuc(Dcm/DcmConfigSet/DcmDsp/DcmDspRoutine/DcmDspRoutineUsePort)} == TRUE) Signal = {ecuc(Dcm/DcmConfigSet/DcmDsp/DcmDspRoutine/DcmDspRequestRoutineResults/DcmDspRequestRoutineResultsIn/DcmDspRequestRoutineResultsInSignal.SHORT-NAME)} Routine = {ecuc(Dcm/DcmConfigSet/DcmDsp/DcmDspRoutine.SHORT-NAME)}
Available via	Rte_Dcm_Type.h

E.3.1.19 Dcm_StartDataIn_{Routine}_{Signal}PrimitivType

Name	Dcm_StartDataIn_{Routine}_{Signal}PrimitivType	
Kind	Type	
Derived from	Basetype	Variation
	float32	{ecuc(Dcm/DcmConfigSet/DcmDsp/DcmDspRoutine/DcmDspStartRoutine/DcmDspStartRoutineIn/DcmDspStartRoutineInSignal.DcmDspRoutineSignalType)} == FLOAT
	sint16	{ecuc(Dcm/DcmConfigSet/DcmDsp/DcmDspRoutine/DcmDspStartRoutine/DcmDspStartRoutineIn/DcmDspStartRoutineInSignal.DcmDspRoutineSignalType)} == SINT16
	sint32	{ecuc(Dcm/DcmConfigSet/DcmDsp/DcmDspRoutine/DcmDspStartRoutine/DcmDspStartRoutineIn/DcmDspStartRoutineInSignal.DcmDspRoutineSignalType)} == SINT32
	sint8	{ecuc(Dcm/DcmConfigSet/DcmDsp/DcmDspRoutine/DcmDspStartRoutine/DcmDspStartRoutineIn/DcmDspStartRoutineInSignal.DcmDspRoutineSignalType)} == SINT8
	uint16	{ecuc(Dcm/DcmConfigSet/DcmDsp/DcmDspRoutine/DcmDspStartRoutine/DcmDspStartRoutineIn/DcmDspStartRoutineInSignal.DcmDspRoutineSignalType)} == UINT16
	uint32	{ecuc(Dcm/DcmConfigSet/DcmDsp/DcmDspRoutine/DcmDspStartRoutine/DcmDspStartRoutineIn/DcmDspStartRoutineInSignal.DcmDspRoutineSignalType)} == UINT32
uint8	{ecuc(Dcm/DcmConfigSet/DcmDsp/DcmDspRoutine/DcmDspStartRoutine/DcmDspStartRoutineIn/DcmDspStartRoutineInSignal.DcmDspRoutineSignalType)} == UINT8	
Description	–	
Variation	{ecuc(Dcm/DcmConfigSet/DcmDsp/DcmDspRoutine/DcmDspStartRoutine/DcmDspStartRoutineIn/DcmDspStartRoutineInSignal.DcmDspRoutineSignalType)} == [U S]INT[8 16 32][FLOAT] && ({ecuc(Dcm/DcmConfigSet/DcmDsp/DcmDspRoutine/DcmDspRoutineUsePort)} == TRUE) Signal = {ecuc(Dcm/DcmConfigSet/DcmDsp/DcmDspRoutine/DcmDspStartRoutine/DcmDspStartRoutineIn/DcmDspStartRoutineInSignal.SHORT-NAME)} Routine = {ecuc(Dcm/DcmConfigSet/DcmDsp/DcmDspRoutine.SHORT-NAME)}	
Available via	Rte_Dcm_Type.h	

E.3.1.20 Dcm_StartDataIn_{Routine}_{Signal}Type

Name	Dcm_StartDataIn_{Routine}_{Signal}Type	
Kind	Type	
Derived from	Basetype	Variation
	Dcm_StartDataIn_{Routine}_{Signal}PrimitivType	{{ecuc(Dcm/DcmConfigSet/DcmDsp/DcmDspRoutine/DcmDspStartRoutine/DcmDspStartRoutineIn/DcmDspStartRoutineInSignal.DcmDspRoutineSignalType)} == ([U S]INT[8 16 32] FLOAT)}
	Dcm_StartDataIn_{Routine}_{Signal}ArrayType	{{ecuc(Dcm/DcmConfigSet/DcmDsp/DcmDspRoutine/DcmDspStartRoutine/DcmDspStartRoutineIn/DcmDspStartRoutineInSignal.DcmDspRoutineSignalType)} == ([U S]INT[8 16 32] FLOAT)_N}
	Dcm_StartDataIn_{Routine}_{Signal}StructuredType	DcmDspStartRoutineInSignal with at least one DcmDspStartRoutineInSignalCompositeSignalRef.
Description	-	
Variation	{{ecuc(Dcm/DcmConfigSet/DcmDsp/DcmDspRoutine/DcmDspRoutineUsePort)} == TRUE} Signal = {ecuc(Dcm/DcmConfigSet/DcmDsp/DcmDspRoutine/DcmDspStartRoutine/DcmDspStartRoutineIn/DcmDspStartRoutineInSignal.SHORT-NAME)} Routine = {ecuc(Dcm/DcmConfigSet/DcmDsp/DcmDspRoutine.SHORT-NAME)}	
Available via	Rte_Dcm_Type.h	

E.3.1.21 Dcm_StartDataIn_{Routine}_{Signal}ArrayType

Name	Dcm_StartDataIn_{Routine}_{Signal}ArrayType	
Kind	Array	
Element type	Type	Variation
	float32	{{ecuc(Dcm/DcmConfigSet/DcmDsp/DcmDspRoutine/DcmDspStartRoutine/DcmDspStartRoutineIn/DcmDspStartRoutineInSignal.DcmDspRoutineSignalType)} == FLOAT_N}
	sint16	{{ecuc(Dcm/DcmConfigSet/DcmDsp/DcmDspRoutine/DcmDspStartRoutine/DcmDspStartRoutineIn/DcmDspStartRoutineInSignal.DcmDspRoutineSignalType)} == SINT16_N}
	sint32	{{ecuc(Dcm/DcmConfigSet/DcmDsp/DcmDspRoutine/DcmDspStartRoutine/DcmDspStartRoutineIn/DcmDspStartRoutineInSignal.DcmDspRoutineSignalType)} == SINT32_N}
	sint8	{{ecuc(Dcm/DcmConfigSet/DcmDsp/DcmDspRoutine/DcmDspStartRoutine/DcmDspStartRoutineIn/DcmDspStartRoutineInSignal.DcmDspRoutineSignalType)} == SINT8_N}
	uint16	{{ecuc(Dcm/DcmConfigSet/DcmDsp/DcmDspRoutine/DcmDspStartRoutine/DcmDspStartRoutineIn/DcmDspStartRoutineInSignal.DcmDspRoutineSignalType)} == UINT16_N}
	uint32	{{ecuc(Dcm/DcmConfigSet/DcmDsp/DcmDspRoutine/DcmDspStartRoutine/DcmDspStartRoutineIn/DcmDspStartRoutineInSignal.DcmDspRoutineSignalType)} == UINT32_N}
	uint8	{{ecuc(Dcm/DcmConfigSet/DcmDsp/DcmDspRoutine/DcmDspStartRoutine/DcmDspStartRoutineIn/DcmDspStartRoutineInSignal.DcmDspRoutineSignalType)} == UINT8_N}
Size	{ecuc(Dcm/DcmConfigSet/DcmDsp/DcmDspRoutine/DcmDspStartRoutine/DcmDspStartRoutineIn/DcmDspStartRoutineInSignal.DcmDspRoutineParameterSize)} Elements	





Description	–
Variation	{ecuc(Dcm/DcmConfigSet/DcmDsp/DcmDspRoutine/DcmDspStartRoutine/DcmDspStartRoutineIn/DcmDspStartRoutineInSignal.DcmDspRoutineSignalType)} == ([U S]INT[8 16 32] FLOAT)_N && ({ecuc(Dcm/DcmConfigSet/DcmDsp/DcmDspRoutine/DcmDspRoutineUsePort)} == TRUE) Signal = {ecuc(Dcm/DcmConfigSet/DcmDsp/DcmDspRoutine/DcmDspStartRoutine/DcmDspStartRoutineIn/DcmDspStartRoutineInSignal.SHORT-NAME)} Routine = {ecuc(Dcm/DcmConfigSet/DcmDsp/DcmDspRoutine.SHORT-NAME)}
Available via	Rte_Dcm_Type.h

E.3.1.22 Dcm_StartDataOut_{Routine}_{Signal}PrimitivType

Name	Dcm_StartDataOut_{Routine}_{Signal}PrimitivType	
Kind	Type	
Derived from	Basetype	Variation
	float32	{ecuc(Dcm/DcmConfigSet/DcmDsp/DcmDspRoutine/DcmDspStartRoutine/DcmDspStartRoutineOut/DcmDspStartRoutineOutSignal.DcmDspRoutineSignalType)} == FLOAT
	sint16	{ecuc(Dcm/DcmConfigSet/DcmDsp/DcmDspRoutine/DcmDspStartRoutine/DcmDspStartRoutineOut/DcmDspStartRoutineOutSignal.DcmDspRoutineSignalType)} == SINT16
	sint32	{ecuc(Dcm/DcmConfigSet/DcmDsp/DcmDspRoutine/DcmDspStartRoutine/DcmDspStartRoutineOut/DcmDspStartRoutineOutSignal.DcmDspRoutineSignalType)} == SINT32
	sint8	{ecuc(Dcm/DcmConfigSet/DcmDsp/DcmDspRoutine/DcmDspStartRoutine/DcmDspStartRoutineOut/DcmDspStartRoutineOutSignal.DcmDspRoutineSignalType)} == SINT8
	uint16	{ecuc(Dcm/DcmConfigSet/DcmDsp/DcmDspRoutine/DcmDspStartRoutine/DcmDspStartRoutineOut/DcmDspStartRoutineOutSignal.DcmDspRoutineSignalType)} == UINT16
	uint32	{ecuc(Dcm/DcmConfigSet/DcmDsp/DcmDspRoutine/DcmDspStartRoutine/DcmDspStartRoutineOut/DcmDspStartRoutineOutSignal.DcmDspRoutineSignalType)} == UINT32
	uint8	{ecuc(Dcm/DcmConfigSet/DcmDsp/DcmDspRoutine/DcmDspStartRoutine/DcmDspStartRoutineOut/DcmDspStartRoutineOutSignal.DcmDspRoutineSignalType)} == UINT8
Description	–	
Variation	{ecuc(Dcm/DcmConfigSet/DcmDsp/DcmDspRoutine/DcmDspStartRoutine/DcmDspStartRoutineOut/DcmDspStartRoutineOutSignal.DcmDspRoutineSignalType)} == [U S]INT[8 16 32] FLOAT && ({ecuc(Dcm/DcmConfigSet/DcmDsp/DcmDspRoutine/DcmDspRoutineUsePort)} == TRUE) Signal = {ecuc(Dcm/DcmConfigSet/DcmDsp/DcmDspRoutine/DcmDspStartRoutine/DcmDspStartRoutineOut/DcmDspStartRoutineOutSignal.SHORT-NAME)} Routine = {ecuc(Dcm/DcmConfigSet/DcmDsp/DcmDspRoutine.SHORT-NAME)}	
Available via	Rte_Dcm_Type.h	

E.3.1.23 Dcm_StartDataOut_{Routine}_{Signal}Type

Name	Dcm_StartDataOut_{Routine}_{Signal}Type	
Kind	Type	
Derived from	Basetype	Variation
	Dcm_StartDataOut_{Routine}_{Signal}PrimitiveType	{{ecuc(Dcm/DcmConfigSet/DcmDsp/DcmDspRoutine/DcmDspStartRoutine/DcmDspStartRoutineOut/DcmDspStartRoutineOutSignal.DcmDspRoutineSignalType)} == ([U S]INT[8 16 32] FLOAT)}
	Dcm_StartDataOut_{Routine}_{Signal}ArrayType	{{ecuc(Dcm/DcmConfigSet/DcmDsp/DcmDspRoutine/DcmDspStartRoutine/DcmDspStartRoutineOut/DcmDspStartRoutineOutSignal.DcmDspRoutineSignalType)} == ([U S]INT[8 16 32] FLOAT)_N}
	Dcm_StartDataOut_{Routine}_{Signal}StructuredType	DcmDspStartRoutineOutSignal with at least one DcmDspStartRoutineOutSignalCompositeSignalRef.
Description	–	
Variation	{{ecuc(Dcm/DcmConfigSet/DcmDsp/DcmDspRoutine/DcmDspRoutineUsePort)} == TRUE) Signal = {ecuc(Dcm/DcmConfigSet/DcmDsp/DcmDspRoutine/DcmDspStartRoutine/DcmDspStartRoutineOut/DcmDspStartRoutineOutSignal.SHORT-NAME)} Routine = {ecuc(Dcm/DcmConfigSet/DcmDsp/DcmDspRoutine.SHORT-NAME)}	
Available via	Rte_Dcm_Type.h	

E.3.1.24 Dcm_StartDataOut_{Routine}_{Signal}ArrayType

Name	Dcm_StartDataOut_{Routine}_{Signal}ArrayType	
Kind	Array	
Element type	Type	Variation
	float32	{{ecuc(Dcm/DcmConfigSet/DcmDsp/DcmDspRoutine/DcmDspStartRoutine/DcmDspStartRoutineOut/DcmDspStartRoutineOutSignal.DcmDspRoutineSignalType)} == FLOAT_N}
	sint16	{{ecuc(Dcm/DcmConfigSet/DcmDsp/DcmDspRoutine/DcmDspStartRoutine/DcmDspStartRoutineOut/DcmDspStartRoutineOutSignal.DcmDspRoutineSignalType)} == SINT16_N}
	sint32	{{ecuc(Dcm/DcmConfigSet/DcmDsp/DcmDspRoutine/DcmDspStartRoutine/DcmDspStartRoutineOut/DcmDspStartRoutineOutSignal.DcmDspRoutineSignalType)} == SINT32_N}
	sint8	{{ecuc(Dcm/DcmConfigSet/DcmDsp/DcmDspRoutine/DcmDspStartRoutine/DcmDspStartRoutineOut/DcmDspStartRoutineOutSignal.DcmDspRoutineSignalType)} == SINT8_N}
	uint16	{{ecuc(Dcm/DcmConfigSet/DcmDsp/DcmDspRoutine/DcmDspStartRoutine/DcmDspStartRoutineOut/DcmDspStartRoutineOutSignal.DcmDspRoutineSignalType)} == UINT16_N}
	uint32	{{ecuc(Dcm/DcmConfigSet/DcmDsp/DcmDspRoutine/DcmDspStartRoutine/DcmDspStartRoutineOut/DcmDspStartRoutineOutSignal.DcmDspRoutineSignalType)} == UINT32_N}
uint8	{{ecuc(Dcm/DcmConfigSet/DcmDsp/DcmDspRoutine/DcmDspStartRoutine/DcmDspStartRoutineOut/DcmDspStartRoutineOutSignal.DcmDspRoutineSignalType)} == UINT8_N}	





Size	{ecuc(Dcm/DcmConfigSet/DcmDsp/DcmDspRoutine/DcmDspStartRoutine/DcmDspStartRoutineOut/DcmDspStartRoutineOutSignal.DcmDspRoutineParameterSize)} Elements
Description	–
Variation	((ecuc(Dcm/DcmConfigSet/DcmDsp/DcmDspRoutine/DcmDspStartRoutine/DcmDspStartRoutineOut/DcmDspStartRoutineOutSignal.DcmDspRoutineSignalType)) == ([U S]INT[8 16 32] FLOAT)_N) && ((ecuc(Dcm/DcmConfigSet/DcmDsp/DcmDspRoutine/DcmDspRoutineUsePort)) == TRUE) Signal = {ecuc(Dcm/DcmConfigSet/DcmDsp/DcmDspRoutine/DcmDspStartRoutine/DcmDspStartRoutineOut/DcmDspStartRoutineOutSignal.SHORT-NAME)} Routine = {ecuc(Dcm/DcmConfigSet/DcmDsp/DcmDspRoutine.SHORT-NAME)}
Available via	Rte_Dcm_Type.h

E.3.1.25 Dcm_StartFlexibleInArrayData_{Routine}_{Signal}Type

Name	Dcm_StartFlexibleInArrayData_{Routine}_{Signal}Type		
Kind	Array	Element type	uint8
Size	{(ecuc(Dcm/DcmConfigSet/DcmDsp/DcmDspRoutine/DcmDspStartRoutine/DcmDspStartRoutineIn/DcmDspStartRoutineInSignal.DcmDspRoutineParameterSize)} Elements		
Description	–		
Variation	((ecuc(Dcm/DcmConfigSet/DcmDsp/DcmDspRoutine/DcmDspStartRoutine/DcmDspStartRoutineIn/DcmDspStartRoutineInSignal.DcmDspRoutineSignalType)) == VARIABLE_LENGTH) && ((ecuc(Dcm/DcmConfigSet/DcmDsp/DcmDspRoutine/DcmDspRoutineUsePort)) == TRUE) Signal = {ecuc(Dcm/DcmConfigSet/DcmDsp/DcmDspRoutine/DcmDspStartRoutine/DcmDspStartRoutineIn/DcmDspStartRoutineInSignal.SHORT-NAME)} Routine = {ecuc(Dcm/DcmConfigSet/DcmDsp/DcmDspRoutine.SHORT-NAME)}		
Available via	Rte_Dcm_Type.h		

E.3.1.26 Dcm_StartFlexibleOutArrayData_{Routine}_{Signal}Type

Name	Dcm_StartFlexibleOutArrayData_{Routine}_{Signal}Type		
Kind	Array	Element type	uint8
Size	{(ecuc(Dcm/DcmConfigSet/DcmDsp/DcmDspRoutine/DcmDspStartRoutine/DcmDspStartRoutineOut/DcmDspStartRoutineOutSignal.DcmDspRoutineParameterSize)} Elements		
Description	–		
Variation	((ecuc(Dcm/DcmConfigSet/DcmDsp/DcmDspRoutine/DcmDspStartRoutine/DcmDspStartRoutineOut/DcmDspStartRoutineOutSignal.DcmDspRoutineSignalType)) == VARIABLE_LENGTH) && ((ecuc(Dcm/DcmConfigSet/DcmDsp/DcmDspRoutine/DcmDspRoutineUsePort)) == TRUE) Signal = {ecuc(Dcm/DcmConfigSet/DcmDsp/DcmDspRoutine/DcmDspStartRoutine/DcmDspStartRoutineOut/DcmDspStartRoutineOutSignal.SHORT-NAME)} Routine = {ecuc(Dcm/DcmConfigSet/DcmDsp/DcmDspRoutine.SHORT-NAME)}		
Available via	Rte_Dcm_Type.h		

E.3.1.27 Dcm_StopDataIn_{Routine}_{Signal}PrimitivType

Name	Dcm_StopDataIn_{Routine}_{Signal}PrimitivType	
Kind	Type	
Derived from	Basetype	Variation
	float32	{ecuc(Dcm/DcmConfigSet/DcmDsp/DcmDspRoutine/DcmDspStopRoutine/DcmDspStopRoutineIn/DcmDspStopRoutineInSignal.DcmDspRoutineSignalType)} == FLOAT
	sint16	{ecuc(Dcm/DcmConfigSet/DcmDsp/DcmDspRoutine/DcmDspStopRoutine/DcmDspStopRoutineIn/DcmDspStopRoutineInSignal.DcmDspRoutineSignalType)} == SINT16
	sint32	{ecuc(Dcm/DcmConfigSet/DcmDsp/DcmDspRoutine/DcmDspStopRoutine/DcmDspStopRoutineIn/DcmDspStopRoutineInSignal.DcmDspRoutineSignalType)} == SINT32
	sint8	{ecuc(Dcm/DcmConfigSet/DcmDsp/DcmDspRoutine/DcmDspStopRoutine/DcmDspStopRoutineIn/DcmDspStopRoutineInSignal.DcmDspRoutineSignalType)} == SINT8
	uint16	{ecuc(Dcm/DcmConfigSet/DcmDsp/DcmDspRoutine/DcmDspStopRoutine/DcmDspStopRoutineIn/DcmDspStopRoutineInSignal.DcmDspRoutineSignalType)} == UINT16
	uint32	{ecuc(Dcm/DcmConfigSet/DcmDsp/DcmDspRoutine/DcmDspStopRoutine/DcmDspStopRoutineIn/DcmDspStopRoutineInSignal.DcmDspRoutineSignalType)} == UINT32
	uint8	{ecuc(Dcm/DcmConfigSet/DcmDsp/DcmDspRoutine/DcmDspStopRoutine/DcmDspStopRoutineIn/DcmDspStopRoutineInSignal.DcmDspRoutineSignalType)} == UINT8
Description	–	
Variation	({ecuc(Dcm/DcmConfigSet/DcmDsp/DcmDspRoutine/DcmDspStopRoutine/DcmDspStopRoutineIn/DcmDspStopRoutineInSignal.DcmDspRoutineSignalType)} == ([U S]INT[8 16 32] FLOAT)) && ({ecuc(Dcm/DcmConfigSet/DcmDsp/DcmDspRoutine/DcmDspRoutineUsePort)} == TRUE) Signal = {ecuc(Dcm/DcmConfigSet/DcmDsp/DcmDspRoutine/DcmDspStopRoutine/DcmDspStopRoutineIn/DcmDspStopRoutineInSignal.SHORT-NAME)} Routine = {ecuc(Dcm/DcmConfigSet/DcmDsp/DcmDspRoutine.SHORT-NAME)}	
Available via	Rte_Dcm_Type.h	

E.3.1.28 Dcm_StopDataIn_{Routine}_{Signal}Type

Name	Dcm_StopDataIn_{Routine}_{Signal}Type	
Kind	Type	
Derived from	Basetype	Variation
	Dcm_StopDataIn_{Routine}_{Signal}PrimitivType	({ecuc(Dcm/DcmConfigSet/DcmDsp/DcmDspRoutine/DcmDspStopRoutine/DcmDspStopRoutineIn/DcmDspStopRoutineInSignal.DcmDspRoutineSignalType)} == ([U S]INT[8 16 32] FLOAT)) && ([U S]INT[8 16 32] FLOAT)
	Dcm_StopDataIn_{Routine}_{Signal}ArrayType	({ecuc(Dcm/DcmConfigSet/DcmDsp/DcmDspRoutine/DcmDspStopRoutine/DcmDspStopRoutineIn/DcmDspStopRoutineInSignal.DcmDspRoutineSignalType)} == ([U S]INT[8 16 32] FLOAT)_N)
Dcm_StopDataIn_{Routine}_{Signal}StructuredType	DcmDspStopRoutineInSignal with at least one DcmDspStopRoutineInSignalCompositeSignalRef.	





Description	–
Variation	{ecuc(Dcm/DcmConfigSet/DcmDsp/DcmDspRoutine/DcmDspRoutineUsePort)} == TRUE Signal = {ecuc(Dcm/DcmConfigSet/DcmDsp/DcmDspRoutine/DcmDspStopRoutine/DcmDspStopRoutineIn/DcmDspStopRoutineInSignal.SHORT-NAME)} Routine = {ecuc(Dcm/DcmConfigSet/DcmDsp/DcmDspRoutine.SHORT-NAME)}
Available via	Rte_Dcm_Type.h

E.3.1.29 Dcm_StopDataIn_{Routine}_{Signal}ArrayType

Name	Dcm_StopDataIn_{Routine}_{Signal}ArrayType	
Kind	Array	
Element type	Type	Variation
	float32	{ecuc(Dcm/DcmConfigSet/DcmDsp/DcmDspRoutine/DcmDspStopRoutine/DcmDspStopRoutineIn/DcmDspStopRoutineInSignal.DcmDspRoutineSignalType)} == FLOAT_N
	sint16	{ecuc(Dcm/DcmConfigSet/DcmDsp/DcmDspRoutine/DcmDspStopRoutine/DcmDspStopRoutineIn/DcmDspStopRoutineInSignal.DcmDspRoutineSignalType)} == SINT16_N
	sint32	{ecuc(Dcm/DcmConfigSet/DcmDsp/DcmDspRoutine/DcmDspStopRoutine/DcmDspStopRoutineIn/DcmDspStopRoutineInSignal.DcmDspRoutineSignalType)} == SINT32_N
	sint8	{ecuc(Dcm/DcmConfigSet/DcmDsp/DcmDspRoutine/DcmDspStopRoutine/DcmDspStopRoutineIn/DcmDspStopRoutineInSignal.DcmDspRoutineSignalType)} == SINT8_N
	uint16	{ecuc(Dcm/DcmConfigSet/DcmDsp/DcmDspRoutine/DcmDspStopRoutine/DcmDspStopRoutineIn/DcmDspStopRoutineInSignal.DcmDspRoutineSignalType)} == UINT16_N
	uint32	{ecuc(Dcm/DcmConfigSet/DcmDsp/DcmDspRoutine/DcmDspStopRoutine/DcmDspStopRoutineIn/DcmDspStopRoutineInSignal.DcmDspRoutineSignalType)} == UINT32_N
	uint8	{ecuc(Dcm/DcmConfigSet/DcmDsp/DcmDspRoutine/DcmDspStopRoutine/DcmDspStopRoutineIn/DcmDspStopRoutineInSignal.DcmDspRoutineSignalType)} == UINT8_N
Size	{ecuc(Dcm/DcmConfigSet/DcmDsp/DcmDspRoutine/DcmDspStopRoutine/DcmDspStopRoutineIn/DcmDspStopRoutineInSignal.DcmDspRoutineParameterSize)} Elements	
Description	–	
Variation	{ecuc(Dcm/DcmConfigSet/DcmDsp/DcmDspRoutine/DcmDspStopRoutine/DcmDspStopRoutineIn/DcmDspStopRoutineInSignal.DcmDspRoutineSignalType)} == ([U S]INT[8 16 32] FLOAT)_N && {ecuc(Dcm/DcmConfigSet/DcmDsp/DcmDspRoutine/DcmDspRoutineUsePort)} == TRUE Signal = {ecuc(Dcm/DcmConfigSet/DcmDsp/DcmDspRoutine/DcmDspStopRoutine/DcmDspStopRoutineIn/DcmDspStopRoutineInSignal.SHORT-NAME)} Routine = {ecuc(Dcm/DcmConfigSet/DcmDsp/DcmDspRoutine.SHORT-NAME)}	
Available via	Rte_Dcm_Type.h	

E.3.1.30 Dcm_StopDataOut_{Routine}_{Signal}PrimitivType

Name	Dcm_StopDataOut_{Routine}_{Signal}PrimitivType	
Kind	Type	
Derived from	Basetype	Variation
	float32	{ecuc(Dcm/DcmConfigSet/DcmDsp/DcmDspRoutine/DcmDspStopRoutine/DcmDspStopRoutineOut/DcmDspStopRoutineOutSignal.DcmDspRoutineSignalType)} == FLOAT
	sint16	{ecuc(Dcm/DcmConfigSet/DcmDsp/DcmDspRoutine/DcmDspStopRoutine/DcmDspStopRoutineOut/DcmDspStopRoutineOutSignal.DcmDspRoutineSignalType)} == SINT16
	sint32	{ecuc(Dcm/DcmConfigSet/DcmDsp/DcmDspRoutine/DcmDspStopRoutine/DcmDspStopRoutineOut/DcmDspStopRoutineOutSignal.DcmDspRoutineSignalType)} == SINT32
	sint8	{ecuc(Dcm/DcmConfigSet/DcmDsp/DcmDspRoutine/DcmDspStopRoutine/DcmDspStopRoutineOut/DcmDspStopRoutineOutSignal.DcmDspRoutineSignalType)} == SINT8
	uint16	{ecuc(Dcm/DcmConfigSet/DcmDsp/DcmDspRoutine/DcmDspStopRoutine/DcmDspStopRoutineOut/DcmDspStopRoutineOutSignal.DcmDspRoutineSignalType)} == UINT16
	uint32	{ecuc(Dcm/DcmConfigSet/DcmDsp/DcmDspRoutine/DcmDspStopRoutine/DcmDspStopRoutineOut/DcmDspStopRoutineOutSignal.DcmDspRoutineSignalType)} == UINT32
	uint8	{ecuc(Dcm/DcmConfigSet/DcmDsp/DcmDspRoutine/DcmDspStopRoutine/DcmDspStopRoutineOut/DcmDspStopRoutineOutSignal.DcmDspRoutineSignalType)} == UINT8
Description	-	
Variation	({ecuc(Dcm/DcmConfigSet/DcmDsp/DcmDspRoutine/DcmDspStopRoutine/DcmDspStopRoutineOut/DcmDspStopRoutineOutSignal.DcmDspRoutineSignalType)} == [U S]INT[8 16 32] FLOAT) && ({ecuc(Dcm/DcmConfigSet/DcmDsp/DcmDspRoutine/DcmDspRoutineUsePort)} == TRUE) Signal = {ecuc(Dcm/DcmConfigSet/DcmDsp/DcmDspRoutine/DcmDspStopRoutine/DcmDspStopRoutineOut/DcmDspStopRoutineOutSignal.SHORT-NAME)} Routine = {ecuc(Dcm/DcmConfigSet/DcmDsp/DcmDspRoutine.SHORT-NAME)}	
Available via	Rte_Dcm_Type.h	

E.3.1.31 Dcm_StopDataOut_{Routine}_{Signal}Type

Name	Dcm_StopDataOut_{Routine}_{Signal}Type	
Kind	Type	
Derived from	Basetype	Variation
	Dcm_StopDataOut_{Routine}_{Signal}PrimitivType	({ecuc(Dcm/DcmConfigSet/DcmDsp/DcmDspRoutine/DcmDspStopRoutine/DcmDspStopRoutineOut/DcmDspStopRoutineOutSignal.DcmDspRoutineSignalType)} == ([U S]INT[8 16 32] FLOAT))
	Dcm_StopDataOut_{Routine}_{Signal}ArrayType	({ecuc(Dcm/DcmConfigSet/DcmDsp/DcmDspRoutine/DcmDspStopRoutine/DcmDspStopRoutineOut/DcmDspStopRoutineOutSignal.DcmDspRoutineSignalType)} == ([U S]INT[8 16 32] FLOAT)_N)





	Dcm_StopDataOut_{Routine}_{Signal}Structured Type	DcmDspStopRoutineOutSignal with at least one DcmDspStopRoutineOutSignalCompositeSignalRef.
Description	–	
Variation	({ecuc(Dcm/DcmConfigSet/DcmDsp/DcmDspRoutine/DcmDspRoutineUsePort)} == TRUE) Signal = {ecuc(Dcm/DcmConfigSet/DcmDsp/DcmDspRoutine/DcmDspStopRoutine/DcmDspStopRoutineOut/DcmDspStopRoutineOutSignal.SHORT-NAME)} Routine = {ecuc(Dcm/DcmConfigSet/DcmDsp/DcmDspRoutine.SHORT-NAME)}	
Available via	Rte_Dcm_Type.h	

E.3.1.32 Dcm_StopDataOut_{Routine}_{Signal}ArrayType

Name	Dcm_StopDataOut_{Routine}_{Signal}ArrayType	
Kind	Array	
Element type	Type	Variation
	float32	{ecuc(Dcm/DcmConfigSet/DcmDsp/DcmDspRoutine/DcmDspStopRoutine/DcmDspStopRoutineOut/DcmDspStopRoutineOutSignal.DcmDspRoutineSignalType)} == FLOAT_N
	sint16	{ecuc(Dcm/DcmConfigSet/DcmDsp/DcmDspRoutine/DcmDspStopRoutine/DcmDspStopRoutineOut/DcmDspStopRoutineOutSignal.DcmDspRoutineSignalType)} == SINT16_N
	sint32	{ecuc(Dcm/DcmConfigSet/DcmDsp/DcmDspRoutine/DcmDspStopRoutine/DcmDspStopRoutineOut/DcmDspStopRoutineOutSignal.DcmDspRoutineSignalType)} == SINT32_N
	sint8	{ecuc(Dcm/DcmConfigSet/DcmDsp/DcmDspRoutine/DcmDspStopRoutine/DcmDspStopRoutineOut/DcmDspStopRoutineOutSignal.DcmDspRoutineSignalType)} == SINT8_N
	uint16	{ecuc(Dcm/DcmConfigSet/DcmDsp/DcmDspRoutine/DcmDspStopRoutine/DcmDspStopRoutineOut/DcmDspStopRoutineOutSignal.DcmDspRoutineSignalType)} == UINT16_N
	uint32	{ecuc(Dcm/DcmConfigSet/DcmDsp/DcmDspRoutine/DcmDspStopRoutine/DcmDspStopRoutineOut/DcmDspStopRoutineOutSignal.DcmDspRoutineSignalType)} == UINT32_N
	uint8	{ecuc(Dcm/DcmConfigSet/DcmDsp/DcmDspRoutine/DcmDspStopRoutine/DcmDspStopRoutineOut/DcmDspStopRoutineOutSignal.DcmDspRoutineSignalType)} == UINT8_N
Size	{ecuc(Dcm/DcmConfigSet/DcmDsp/DcmDspRoutine/DcmDspStopRoutine/DcmDspStopRoutineOut/DcmDspStopRoutineOutSignal.DcmDspRoutineParameterSize)} Elements	
Description	–	
Variation	({ecuc(Dcm/DcmConfigSet/DcmDsp/DcmDspRoutine/DcmDspStopRoutine/DcmDspStopRoutineOut/DcmDspStopRoutineOutSignal.DcmDspRoutineSignalType)} == ([U S INT[8 16 32] FLOAT)_N) && ({ecuc(Dcm/DcmConfigSet/DcmDsp/DcmDspRoutine/DcmDspRoutineUsePort)} == TRUE) Signal = {ecuc(Dcm/DcmConfigSet/DcmDsp/DcmDspRoutine/DcmDspStopRoutine/DcmDspStopRoutineOut/DcmDspStopRoutineOutSignal.SHORT-NAME)} Routine = {ecuc(Dcm/DcmConfigSet/DcmDsp/DcmDspRoutine.SHORT-NAME)}	
Available via	Rte_Dcm_Type.h	

E.3.1.33 Dcm_StopFlexibleInArrayData_{Routine}_{Signal}Type

Name	Dcm_StopFlexibleInArrayData_{Routine}_{Signal}Type		
Kind	Array	Element type	uint8
Size	{(ecuc(Dcm/DcmConfigSet/DcmDsp/DcmDspRoutine/DcmDspStopRoutine/DcmDspStopRoutineIn/DcmDspStopRoutineInSignal.DcmDspRoutineParameterSize) Elements		
Description	–		
Variation	((ecuc(Dcm/DcmConfigSet/DcmDsp/DcmDspRoutine/DcmDspStopRoutine/DcmDspStopRoutineIn/DcmDspStopRoutineInSignal.DcmDspRoutineSignalType)) == VARIABLE_LENGTH) && ((ecuc(Dcm/DcmConfigSet/DcmDsp/DcmDspRoutine/DcmDspRoutineUsePort)) == TRUE) Signal = {ecuc(Dcm/DcmConfigSet/DcmDsp/DcmDspRoutine/DcmDspStopRoutine/DcmDspStopRoutineIn/DcmDspStopRoutineInSignal.SHORT-NAME)} Routine = {ecuc(Dcm/DcmConfigSet/DcmDsp/DcmDspRoutine.SHORT-NAME)}		
Available via	Rte_Dcm_Type.h		

E.3.1.34 Dcm_StopFlexibleOutArrayData_{Routine}_{Signal}Type

Name	Dcm_StopFlexibleOutArrayData_{Routine}_{Signal}Type		
Kind	Array	Element type	uint8
Size	{(ecuc(Dcm/DcmConfigSet/DcmDsp/DcmDspRoutine/DcmDspStopRoutine/DcmDspStopRoutineOut/DcmDspStopRoutineOutSignal.DcmDspRoutineParameterSize) Elements		
Description	–		
Variation	((ecuc(Dcm/DcmConfigSet/DcmDsp/DcmDspRoutine/DcmDspStopRoutine/DcmDspStopRoutineOut/DcmDspStopRoutineOutSignal.DcmDspRoutineSignalType)) == VARIABLE_LENGTH) && ((ecuc(Dcm/DcmConfigSet/DcmDsp/DcmDspRoutine/DcmDspRoutineUsePort)) == TRUE) Signal = {ecuc(Dcm/DcmConfigSet/DcmDsp/DcmDspRoutine/DcmDspStopRoutine/DcmDspStopRoutineOut/DcmDspStopRoutineOutSignal.SHORT-NAME)} Routine = {ecuc(Dcm/DcmConfigSet/DcmDsp/DcmDspRoutine.SHORT-NAME)}		
Available via	Rte_Dcm_Type.h		

E.3.1.35 Dcm_KeyArray_{SecurityLevel}Type

Name	Dcm_KeyArray_{SecurityLevel}Type		
Kind	Array	Element type	uint8
Size	{ecuc(Dcm/DcmConfigSet/DcmDsp/DcmDspSecurity/DcmDspSecurityRow.DcmDspSecurityKeySize)} Elements		
Description	–		
Variation	{ecuc(Dcm/DcmConfigSet/DcmDsp/DcmDspSecurity/DcmDspSecurityRow.DcmDspSecurityUsePort)} == USE_ASYNC_CLIENT_SERVER SecurityLevel = {ecuc(Dcm/DcmConfigSet/DcmDsp/DcmDspSecurity/DcmDspSecurityRow.SHORT-NAME)}		
Available via	Rte_Dcm_Type.h		

E.3.1.36 Dcm_SeedArray_{SecurityLevel}Type

Name	Dcm_SeedArray_{SecurityLevel}Type		
Kind	Array	Element type	uint8
Size	{ecuc(Dcm/DcmConfigSet/DcmDsp/DcmDspSecurity/DcmDspSecurityRow.DcmDspSecuritySeed Size)} Elements		
Description	–		
Variation	{ecuc(Dcm/DcmConfigSet/DcmDsp/DcmDspSecurity/DcmDspSecurityRow.DcmDspSecurityUse Port)} == USE_ASYNC_CLIENT_SERVER SecurityLevel = {ecuc(Dcm/DcmConfigSet/DcmDsp/DcmDspSecurity/DcmDspSecurity Row.SHORT-NAME)}		
Available via	Rte_Dcm_Type.h		

E.3.1.37 Dcm_SecurityAccessDataRecordArray_{SecurityLevel}Type

Name	Dcm_SecurityAccessDataRecordArray_{SecurityLevel}Type		
Kind	Array	Element type	uint8
Size	{ecuc(Dcm/DcmConfigSet/DcmDsp/DcmDsp/DcmDspSecurity/DcmDspSecurityRow/DcmDsp SecurityADRSIZE)} Elements		
Description	–		
Variation	({ecuc(Dcm/DcmConfigSet/DcmDsp/DcmDspSecurity/DcmDspSecurityRow.DcmDspSecurityUse Port)} == USE_ASYNC_CLIENT_SERVER) && ({ecuc(Dcm/DcmConfigSet/DcmDsp/DcmDsp Security/DcmDspSecurityRow.DcmDspSecurityADRSIZE)} != NULL) SecurityLevel = {ecuc(Dcm/DcmConfigSet/DcmDsp/DcmDspSecurity/DcmDspSecurity Row.SHORT-NAME)}		
Available via	Rte_Dcm_Type.h		

E.3.1.38 Dcm_RequestDataArrayType

Name	Dcm_RequestDataArrayType		
Kind	Array	Element type	uint8
Size	(MAX({ecuc(Dcm/DcmConfigSet/DcmDsl/DcmDslProtocol/DcmDslProtocolRow/DcmDslProtocol RxBufferID->DcmDslBuffer.DcmDslBufferSize)}) - 1) Elements		
Description	–		
Variation	–		
Available via	Rte_Dcm_Type.h		

E.3.1.39 Dcm_ControlMask_{DID}Type

Name	Dcm_ControlMask_{DID}Type		
Kind	Type		
Derived from	Basetype	Variation	
	Dcm_ControlMask_{Data} ArrayType	<pre>(((ecuc(Dcm/DcmConfigSet/DcmDsp/DcmDspDid/DcmDspDidInfoRef->DcmDspDidInfo/DcmDspDidControl/DcmDspDidControlMaskSize)) >= 0x05) && ((ecuc(Dcm/DcmConfigSet/DcmDsp/DcmDspData.DcmDspDataUsePort)) == (USE_DATA_SYNCH_CLIENT_SERVER USE_DATA_ASYNCH_CLIENT_SERVER USE_DATA_ASYNCH_CLIENT_SERVER_ERROR)))</pre>	
	Dcm_ControlMask_{Data} _PrimitiveType	<pre>((ecuc(Dcm/DcmConfigSet/ DcmDsp/DcmDspDid/ DcmDspDidInfoRef->DcmDspDidInfo/ DcmDspDidControl/ DcmDspDidControlMaskSize)) <= 0x04)</pre>	
Description	-		
Variation	<pre>((ecuc(Dcm/DcmConfigSet/DcmDsp/DcmDspData.DcmDspDataUsePort)) == (USE_DATA_SYNCH_CLIENT_SERVER USE_DATA_ASYNCH_CLIENT_SERVER USE_DATA_ASYNCH_CLIENT_SERVER_ERROR)) && ((ecuc(Dcm/DcmConfigSet/DcmDsp/DcmDspDid/DcmDspDidInfoRef->DcmDspDidInfo/DcmDspDidControl/DcmDspDidControlMask)) == DCM_CONTROLMASK_EXTERNAL) && ((ecuc(Dcm/DcmConfigSet/DcmDsp/DcmDspDid/DcmDspDidInfoRef->DcmDspDidInfo/DcmDspDidControl/DcmDspDidControlEnableMask)) == NULL) DID = ((ecuc(Dcm/DcmConfigSet/DcmDsp/DcmDspDid.SHORT-NAME)))</pre>		
Available via	Rte_Dcm_Type.h		

E.3.1.40 Dcm_inputOutputControlParameterType

Name	Dcm_InputOutputControlParameterType		
Kind	Type		
Derived from	uint8		
Range	DCM_RETURN_CONTROL_TO_ECU	0x00	returnControlToECU
	DCM_RESET_TO_DEFAULT	0x01	resetToDefault
	DCM_FREEZE_CURRENT_STATE	0x02	freezeCurrentState
	DCM_SHORT_TERM_ADJUSTMENT	0x03	shortTermAdjustment
	DCM_IDLE	0xff	Idle state, no request in processing (initial value)
Description	-		
Variation	-		
Available via	Rte_Dcm_Type.h		

E.3.1.41 Dcm_IOOperationRequest_{DID}Type

Name	Dcm_IOOperationRequest_{DID}Type		
Kind	Structure		
Elements	inputOutputControlParameter		
	Type	Dcm_InputOutputControlParameterType	
	Comment	-	
	controlEnableMask		
	Type	Dcm_Cemr_{DID}Type	
	Comment	-	
Description	-		
Variation	<pre> {{ecuc(Dcm/DcmConfigSet/DcmDsp/DcmDspDid/DcmDspDidUsePort)} == (USE_ATOMIC_ SENDER_RECEIVER_INTERFACE)} {{ecuc(Dcm/DcmConfigSet/DcmDsp/DcmDspDid/Dcm DspDidUsePort)} == (USE_ATOMIC_SENDER_RECEIVER_INTERFACE_AS_SERVICE)}&& {{ecuc(Dcm/DcmConfigSet/DcmDsp/DcmDspDid/DcmDspDidInfoRef-> DcmDspDidInfo/DcmDsp DidControl)} != NULL} DID = {{ecuc(Dcm/DcmConfigSet/DcmDsp/DcmDspDid.SHORT-NAME)}} </pre>		
Available via	Rte_Dcm_Type.h		

E.3.1.42 Dcm_IOOperationResponseType

Name	Dcm_IOOperationResponseType		
Kind	Type		
Derived from	uint8		
Range	DCM_POSITIVE_	0x00	positive response (similar to E_
	RESPONSE		OK)
	DCM_GENERAL_REJECT	0x10	NRC generalReject
	DCM_BUSY_REPEAT_	0x21	NRC busyRepeatRequest
	REQUEST		
	DCM_CONDITIONS_NOT_	0x22	NRC conditionsNotCorrect
	CORRECT		
DCM_FAILURE_	0x26	NRC FailurePreventsExecutionOf	
PREVENTS_EXECUTION		RequestedAction	
DCM_REQUEST_OUT_	0x31	NRC requestOutOfRange	
OF_RANGE			
DCM_RESPONSE_	0x78	ResponsePending (similar to E_	
PENDING		PENDING)	
Description	-		
Variation	-		
Available via	Rte_Dcm_Type.h		

E.3.1.43 Dcm_ResponseDataArrayType

Name	Dcm_ResponseDataArrayType		
Kind	Array	Element type	uint8
Size	(MAX({ecuc(Dcm/DcmConfigSet/DcmDsl/DcmDslProtocol/DcmDslProtocolRow/DcmDslProtocolTxBufferRef->DcmDslBuffer.DcmDslBufferSize)}) -1) Elements		
Description	-		
Variation	({ecuc(Dcm/DcmConfigSet/DcmDsp/DcmDspRequestFileTransfer/DcmRequestFileTransferUsePort)} == TRUE)		
Available via	Rte_Dcm_Type.h		

E.3.1.44 Dcm_ControlMask_{Data}ArrayType

Name	Dcm_ControlMask_{Data}ArrayType		
Kind	Array	Element type	uint8
Size	({ecuc(Dcm/DcmConfigSet/DcmDsp/DcmDspDid/DcmDspDidInfoRef->DcmDspDidInfo/DcmDspDidControl/DcmDspDidControlMaskSize)}) Elements		
Description	The current DcmDspData is referenced by the DcmDspDID.		
Variation	(({ecuc(Dcm/DcmConfigSet/DcmDsp/DcmDspDid/DcmDspDidInfoRef->DcmDspDidInfo/DcmDspDidControl/DcmDspDidControlMaskSize)} >= 0x05) && ({ecuc(Dcm/DcmConfigSet/DcmDsp/DcmDspData.DcmDspDataUsePort)} == (USE_DATA_SYNCH_CLIENT_SERVER USE_DATA_ASYNC_CLIENT_SERVER USE_DATA_ASYNC_CLIENT_SERVER_ERROR))) Data = ({ecuc(Dcm/DcmConfigSet/DcmDsp/DcmDspData.SHORT-NAME)})		
Available via	Rte_Dcm_Type.h		

E.3.1.45 Dcm_Cemr_{DID}Type

Name	Dcm_Cemr_{DID}Type		
Kind	Bitfield		
Derived from	Dcm_ControlMask_{DID}Type		
Elements	Variable bit		
	Kind	bit	
	Name	({ecuc(Dcm/DcmConfigSet/DcmDsp/DcmDspDidControl.DcmDspDidControlEnableMask.SHORT-NAME)})	
	Mask	2 ^{ecuc(Dcm/DcmConfigSet/DcmDsp/DcmDspDid/DcmDspDidInfoRef->DcmDspDidInfo/DcmDspDidControl/DcmDspDidControlMaskSize)} * 8 - 1) - {ecuc(Dcm/DcmConfigSet/DcmDsp/DcmDspDid/DcmDspDidInfoRef->DcmDspDidInfo/DcmDspDidControl/DcmDspDidControlEnableMask/DcmDspDidControlMaskBitPosition)})	
Description	Bitmask of data element in control enable mask record.		
Description	-		
Variation	({ecuc(Dcm/DcmConfigSet/DcmDsp/DcmDspDidControl/DcmDspDidControlEnableMask)} != NULL) DID = ({ecuc(Dcm/DcmConfigSet/DcmDsp/DcmDspDid.SHORT-NAME)})		
Available via	Rte_Dcm_Type.h		

E.3.2 Sender-Receiver-Interfaces

Using the concepts of the SW-C template, the interface is defined as follows if Sender-Receiver interface is used (DcmDspDataUsePort set to USE_DATA_SENDER_RECEIVER || USE_DATA_SENDER_RECEIVER_AS_SERVICE):

E.3.2.1 DataServices_{DID}

Name	DataServices_{DID}	
Comment	-	
IsService	({ecuc(Dcm/DcmConfigSet/DcmDsp/DcmDspDid/DcmDspDidUsePort)} == USE_ATOMIC_SENDER_RECEIVER_INTERFACE_AS_SERVICE)	
Variation	(({ecuc(Dcm/DcmConfigSet/DcmDsp/DcmDspDid/DcmDspDidUsePort)} == (USE_ATOMIC_SENDER_RECEIVER_INTERFACE {ecuc(Dcm/DcmConfigSet/DcmDsp/DcmDspDid/DcmDspDidUsePort)} == (USE_ATOMIC_SENDER_RECEIVER_INTERFACE_AS_SERVICE))) DID = {ecuc(Dcm/DcmConfigSet/DcmDsp/DcmDspDid.SHORT-NAME)}	
Data Elements	data	
	Type	{DID}_Struct_DataType
	Variation	DID = {ecuc(Dcm/DcmConfigSet/DcmDsp/DcmDspDid.SHORT-NAME)}

E.3.2.2 DataServices_{Data}

Name	DataServices_{Data}	
Comment	-	
IsService	(({ecuc(Dcm/DcmConfigSet/DcmDsp/DcmDspData/DcmDspDataUsePort)} == USE_DATA_SENDER_RECEIVER_AS_SERVICE) ({ecuc(Dcm/DcmConfigSet/DcmDsp/DcmDspPid/DcmDspPidData/DcmDspPidService01/DcmDspPidDataUsePort)} == USE_DATA_SENDER_RECEIVER_AS_SERVICE))	
Variation	(({ecuc(Dcm/DcmConfigSet/DcmDsp/DcmDspDid/DcmDspDidUsePort)} == USE_DATA_ELEMENT_SPECIFIC_INTERFACES)&&({ecuc(Dcm/DcmConfigSet/DcmDsp/DcmDspData/DcmDspDataUsePort)} == (USE_DATA_SENDER_RECEIVER USE_DATA_SENDER_RECEIVER_AS_SERVICE))) ({ecuc(Dcm/DcmConfigSet/DcmDsp/DcmDspPid/DcmDspPidData/DcmDspPidService01/DcmDspPidDataUsePort)} == (USE_DATA_SENDER_RECEIVER USE_DATA_SENDER_RECEIVER_AS_SERVICE)) Data = ({ecuc(Dcm/DcmConfigSet/DcmDsp/DcmDspData.SHORT-NAME)}) ({ecuc(Dcm/DcmConfigSet/DcmDsp/DcmDspPid/DcmDspPidData.SHORT-NAME)})	
Data Elements	data	
	Type	Dcm_DataElement_{Data}Type
	Variation	Data = ({ecuc(Dcm/DcmConfigSet/DcmDsp/DcmDspData.SHORT-NAME)}) ({ecuc(Dcm/DcmConfigSet/DcmDsp/DcmDspPid/DcmDspPidData.SHORT-NAME)})

E.3.2.3 IOControlRequest_{DID}

Name	IOControlRequest_{DID}	
Comment	Attention: controlState is only valid in case of IOOperationRequest is set to shortTerm Adjustment. The DCM provides a byte stream which could be transformed via transformer into an complex type.	
IsService	true	
Variation	((({ecuc(Dcm/DcmConfigSet/DcmDsp/DcmDspDid/DcmDspDidUsePort)} == (USE_ATOMIC_SENDER_RECEIVER_INTERFACE) ({ecuc(Dcm/DcmConfigSet/DcmDsp/DcmDspDid/DcmDspDidUsePort)} == USE_ATOMIC_SENDER_RECEIVER_INTERFACE_AS_SERVICE)) && ({ecuc(Dcm/DcmConfigSet/DcmDsp/DcmDspDid/DcmDspDidInfoRef-> DcmDspDidInfo/ DcmDspDidControl)} != NULL)) && (({ecuc(Dcm/DcmConfigSet/DcmDsp/DcmDspDid/DcmDspDidInfoRef->DcmDspDidInfo/DcmDspDidControl/DcmDspDidControlMask)} == DCM_CONTROLMASK_EXTERNAL))) DID = ({ecuc(Dcm/DcmConfigSet/DcmDsp/DcmDspDid.SHORT-NAME)})	
Data Elements	underControl	
	Type	Dcm_Cemr_{DID}Type
	Variation	-
	IOOperationRequest	
	Type	Dcm_IOOperationRequest_{DID}Type
	Variation	DID = ({ecuc(Dcm/DcmConfigSet/DcmDsp/DcmDspDid.SHORT-NAME)})
	controlState	
	Type	{DID}_Struct_DataType
Variation	(({ecuc(Dcm/DcmConfigSet/DcmDsp/DcmDspDid/DcmDspDidInfoRef-> DcmDspDidInfo/DcmDspDidControl/DcmDspDidShortTermAdjustment)} == True) DID = ({ecuc(Dcm/DcmConfigSet/DcmDsp/DcmDspDid.SHORT-NAME)})	

E.3.2.4 IOControlResponse_{DID}

Name	IOControlResponse_{DID}	
Comment	-	
IsService	true	
Variation	(({ecuc(Dcm/DcmConfigSet/DcmDsp/DcmDspDid/DcmDspDidUsePort)} == (USE_ATOMIC_SENDER_RECEIVER_INTERFACE USE_ATOMIC_SENDER_RECEIVER_INTERFACE_AS_SERVICE))) && (({ecuc(Dcm/DcmConfigSet/DcmDsp/DcmDspDid/DcmDspDidInfoRef-> DcmDspDidInfo/DcmDspDidControl)} != NULL)) DID = ({ecuc(Dcm/DcmConfigSet/DcmDsp/DcmDspDid.SHORT-NAME)})	
Data Elements	IOOperationResponse	
	Type	Dcm_IOOperationResponseType
	Variation	-

E.3.3 NvDataInterface

E.3.3.1 DataServices_{DID}

Name	DataServices_{DID}	
Comment	–	
IsService	false	
Variation	({ecuc(Dcm/DcmConfigSet/DcmDsp/DcmDspDid/DcmDspDidUsePort)} == USE_ATOMIC_NV_DATA_INTERFACE) DID = {ecuc(Dcm/DcmConfigSet/DcmDsp/DcmDspDid.SHORT-NAME)}	
Data Elements	data	
	Type	{DID}_Struct_DataType
	Variation	DID = ({ecuc(Dcm/DcmConfigSet/DcmDsp/DcmDspDid.SHORT-NAME)})

E.3.4 Client-Server-Interfaces

E.3.4.1 DataServices_{Data}

E.3.4.2 RoutineServices_{RoutineName}

The following interface defines operations needed for the UDS Service RoutineControl (0x31).

Name	RoutineServices_{RoutineName}		
Comment	–		
IsService	true		
Variation	{ecuc(Dcm/DcmConfigSet/DcmDsp/DcmDspRoutine.DcmDspRoutineUsePort)} == TRUE RoutineName = {ecuc(Dcm/DcmConfigSet/DcmDsp/DcmDspRoutine.SHORT-NAME)}		
Possible Errors	0	E_OK	Operation successful
	1	E_NOT_OK	Operation failed
	10	DCM_E_PENDING	Request is not yet finished. Further call(s) required to finish.
	12	DCM_E_FORCE_RCRRP	application request the transmission of a response Response Pending (NRC 0x78)

Operation	RequestResults	
Comment	–	
Mapped to API	Xxx_RequestResults	
Variation	({ecuc(Dcm/DcmConfigSet/DcmDsp/DcmDspRoutine/DcmDspRequestRoutineResults/DcmDspRequestRoutineResultsOut/DcmDspRequestRoutineResultsOutSignal.DcmDspRoutineSignalType)} != VARIABLE_LENGTH) && ({ecuc(Dcm/DcmConfigSet/DcmDsp/DcmDspRoutine/DcmDspRequestRoutineResults/DcmDspRequestRoutineResultsIn/DcmDspRequestRoutineResultsInSignal.DcmDspRoutineSignalType)} != VARIABLE_LENGTH)	
Parameters	DataIn_{Signal}	
	Type	Dcm_RequestDataIn_{Routine}_{Signal}Type
	Direction	IN
	Comment	–





	Variation	Signal = {ecuc(Dcm/DcmConfigSet/DcmDsp/DcmDspRoutine/DcmDspRequestRoutineResults/DcmDspRequestRoutineResultsIn/DcmDspRequestRoutineResultsInSignal.SHORT-NAME)} Routine = {ecuc(Dcm/DcmConfigSet/DcmDsp/DcmDspRoutine.SHORT-NAME)}
	OpStatus	
	Type	Dcm_OpStatusType
	Direction	IN
	Comment	–
	Variation	–
	DataOut_{Signal}	
	Type	Dcm_RequestDataOut_{Routine}_{Signal}Type
	Direction	OUT
	Comment	–
	Variation	Signal = {ecuc(Dcm/DcmConfigSet/DcmDsp/DcmDspRoutine/DcmDspRequestRoutineResults/DcmDspRequestRoutineResultsOut/DcmDspRequestRoutineResultsOutSignal.SHORT-NAME)} Routine = {ecuc(Dcm/DcmConfigSet/DcmDsp/DcmDspRoutine.SHORT-NAME)}
	ErrorCode	
	Type	Dcm_NegativeResponseCodeType
	Direction	OUT
	Comment	–
	Variation	–
Possible Errors	E_OK E_NOT_OK DCM_E_PENDING DCM_E_FORCE_RCRRP	

Operation	RequestResults	
Comment	–	
Mapped to API	Xxx_RequestResults	
Variation	({ecuc(Dcm/DcmConfigSet/DcmDsp/DcmDspRoutine/DcmDspRequestRoutineResults/DcmDspRequestRoutineResultsOut/DcmDspRequestRoutineResultsOutSignal.DcmDspRoutineSignalType)} == VARIABLE_LENGTH) && ({ecuc(Dcm/DcmConfigSet/DcmDsp/DcmDspRoutine/DcmDspRequestRoutineResults/DcmDspRequestRoutineResultsIn/DcmDspRequestRoutineResultsInSignal.DcmDspRoutineSignalType)} != VARIABLE_LENGTH)	
Parameters	DataIn_{Signal}	
	Type	Dcm_RequestDataIn_{Routine}_{Signal}Type
	Direction	IN
	Comment	–
	Variation	Signal = {ecuc(Dcm/DcmConfigSet/DcmDsp/DcmDspRoutine/DcmDspRequestRoutineResults/DcmDspRequestRoutineResultsIn/DcmDspRequestRoutineResultsInSignal.SHORT-NAME)} Routine = {ecuc(Dcm/DcmConfigSet/DcmDsp/DcmDspRoutine.SHORT-NAME)}
	OpStatus	
	Type	Dcm_OpStatusType
	Direction	IN
	Comment	–
Variation	–	





	DataOut_{Signal}
Type	Dcm_RequestDataOut_{Routine}_{Signal}Type
Direction	OUT
Comment	–
Variation	{ecuc(Dcm/DcmConfigSet/DcmDsp/DcmDspRoutine/DcmDspRequestRoutineResults/DcmDspRequestRoutineResultsOut/DcmDspRequestRoutineResultsOutSignal.DcmDspRoutineSignalType)} != VARIABLE_LENGTH Signal = {ecuc(Dcm/DcmConfigSet/DcmDsp/DcmDspRoutine/DcmDspRequestRoutineResults/DcmDspRequestRoutineResultsOut/DcmDspRequestRoutineResultsOutSignal.SHORT-NAME)} Routine = {ecuc(Dcm/DcmConfigSet/DcmDsp/DcmDspRoutine.SHORT-NAME)}
	DataOut_{Signal}
Type	Dcm_RequestFlexibleOutArrayData_{Routine}_{Signal}Type
Direction	OUT
Comment	–
Variation	{ecuc(Dcm/DcmConfigSet/DcmDsp/DcmDspRoutine/DcmDspRequestRoutineResults/DcmDspRequestRoutineResultsOut/DcmDspRequestRoutineResultsOutSignal.DcmDspRoutineSignalType)} == VARIABLE_LENGTH Signal = {ecuc(Dcm/DcmConfigSet/DcmDsp/DcmDspRoutine/DcmDspRequestRoutineResults/DcmDspRequestRoutineResultsOut/DcmDspRequestRoutineResultsOutSignal.SHORT-NAME)} Routine = {ecuc(Dcm/DcmConfigSet/DcmDsp/DcmDspRoutine.SHORT-NAME)}
	currentDataLength
Type	uint16
Direction	OUT
Comment	–
Variation	–
	ErrorCode
Type	Dcm_NegativeResponseCodeType
Direction	OUT
Comment	–
Variation	–
Possible Errors	–

Operation	RequestResults
Comment	–
Mapped to API	Xxx_RequestResults
Variation	((ecuc(Dcm/DcmConfigSet/DcmDsp/DcmDspRoutine/DcmDspRequestRoutineResults/DcmDspRequestRoutineResultsOut/DcmDspRequestRoutineResultsOutSignal.DcmDspRoutineSignalType)} != VARIABLE_LENGTH) && ((ecuc(Dcm/DcmConfigSet/DcmDsp/DcmDspRoutine/DcmDspRequestRoutineResults/DcmDspRequestRoutineResultsIn/DcmDspRequestRoutineResultsInSignal.DcmDspRoutineSignalType)} == VARIABLE_LENGTH)
Parameters	DataIn_{Signal}
Type	Dcm_RequestDataIn_{Routine}_{Signal}Type
Direction	IN
Comment	–





	Variation	Signal = {ecuc(Dcm/DcmConfigSet/DcmDsp/DcmDspRoutine/DcmDspRequestRoutineResults/DcmDspRequestRoutineResultsIn/DcmDspRequestRoutineResultsInSignal.SHORT-NAME)} Routine = {ecuc(Dcm/DcmConfigSet/DcmDsp/DcmDspRoutine.SHORT-NAME)}
	DataIn_{Signal}	
	Type	Dcm_RequestFlexibleInArrayData_{Routine}_{Signal}Type
	Direction	IN
	Comment	–
	Variation	Signal = {ecuc(Dcm/DcmConfigSet/DcmDsp/DcmDspRoutine/DcmDspRequestRoutineResults/DcmDspRequestRoutineResultsIn/DcmDspRequestRoutineResultsInSignal.SHORT-NAME)} Routine = {ecuc(Dcm/DcmConfigSet/DcmDsp/DcmDspRoutine.SHORT-NAME)}
	OpStatus	
	Type	Dcm_OpStatusType
	Direction	IN
	Comment	–
	Variation	–
	DataOut_{Signal}	
	Type	Dcm_RequestDataOut_{Routine}_{Signal}Type
	Direction	OUT
	Comment	–
	Variation	Signal = {ecuc(Dcm/DcmConfigSet/DcmDsp/DcmDspRoutine/DcmDspRequestRoutineResults/DcmDspRequestRoutineResultsOut/DcmDspRequestRoutineResultsOutSignal.SHORT-NAME)} Routine = {ecuc(Dcm/DcmConfigSet/DcmDsp/DcmDspRoutine.SHORT-NAME)}
	ErrorCode	
	Type	Dcm_NegativeResponseCodeType
	Direction	OUT
	Comment	–
	Variation	–
Possible Errors		–

Operation	RequestResults	
Comment	–	
Mapped to API	Xxx_RequestResults	
Variation	(({ecuc(Dcm/DcmConfigSet/DcmDsp/DcmDspRoutine/DcmDspRequestRoutineResults/DcmDspRequestRoutineResultsOut/DcmDspRequestRoutineResultsOutSignal.DcmDspRoutineSignalType)} == VARIABLE_LENGTH) && ({ecuc(Dcm/DcmConfigSet/DcmDsp/DcmDspRoutine/DcmDspRequestRoutineResults/DcmDspRequestRoutineResultsIn/DcmDspRequestRoutineResultsInSignal.DcmDspRoutineSignalType)} == VARIABLE_LENGTH))	
Parameters	DataIn_{Signal}	
	Type	Dcm_RequestDataIn_{Routine}_{Signal}Type
	Direction	IN
	Comment	–





Variation	Signal = {ecuc(Dcm/DcmConfigSet/DcmDsp/DcmDspRoutine/DcmDspRequestRoutineResults/DcmDspRequestRoutineResultsIn/DcmDspRequestRoutineResultsInSignal.SHORT-NAME)} Routine = {ecuc(Dcm/DcmConfigSet/DcmDsp/DcmDspRoutine.SHORT-NAME)}
DataIn_{Signal}	
Type	Dcm_StartFlexibleInArrayData_{Routine}_{Signal}Type
Direction	IN
Comment	–
Variation	–
OpStatus	
Type	Dcm_OpStatusType
Direction	IN
Comment	–
Variation	–
DataOut_{Signal}	
Type	Dcm_RequestDataOut_{Routine}_{Signal}Type
Direction	OUT
Comment	–
Variation	{ecuc(Dcm/DcmConfigSet/DcmDsp/DcmDspRoutine/DcmDspRequestRoutineResults/DcmDspRequestRoutineResultsOut/DcmDspRequestRoutineResultsOutSignal.DcmDspRoutineSignalType)} != VARIABLE_LENGTH Signal = {ecuc(Dcm/DcmConfigSet/DcmDsp/DcmDspRoutine/DcmDspRequestRoutineResults/DcmDspRequestRoutineResultsOut/DcmDspRequestRoutineResultsOutSignal.SHORT-NAME)} Routine = {ecuc(Dcm/DcmConfigSet/DcmDsp/DcmDspRoutine.SHORT-NAME)}
DataOut_{Signal}	
Type	Dcm_RequestFlexibleOutArrayData_{Routine}_{Signal}Type
Direction	OUT
Comment	–
Variation	{ecuc(Dcm/DcmConfigSet/DcmDsp/DcmDspRoutine/DcmDspRequestRoutineResults/DcmDspRequestRoutineResultsOut/DcmDspRequestRoutineResultsOutSignal.DcmDspRoutineSignalType)} == VARIABLE_LENGTH Signal = {ecuc(Dcm/DcmConfigSet/DcmDsp/DcmDspRoutine/DcmDspRequestRoutineResults/DcmDspRequestRoutineResultsOut/DcmDspRequestRoutineResultsOutSignal.SHORT-NAME)} Routine = {ecuc(Dcm/DcmConfigSet/DcmDsp/DcmDspRoutine.SHORT-NAME)}
currentDataLength	
Type	uint16
Direction	OUT
Comment	–
Variation	–
ErrorCode	
Type	Dcm_NegativeResponseCodeType
Direction	OUT
Comment	–
Variation	–
Possible Errors	E_OK E_NOT_OK DCM_E_PENDING DCM_E_FORCE_RCRPP

Operation	RequestResultsConfirmation	
Comment	This operation indicates the transmission of a response to a RequestResultsRoutine request	
Mapped to API	Xxx_RequestResultsConfirmation	
Variation	{ecuc(Dcm/DcmConfigSet/DcmDsp/DcmDspRoutine/DcmDspRequestRoutineResults/DcmDspRequestRoutineResultsConfirmationEnabled)}==TRUE)	
Parameters	ConfirmationStatus	
	Type	Dcm_ConfirmationStatusType
	Direction	IN
	Comment	Confirmation status of a RequestResultsRoutinerequest
Variation	–	
Possible Errors	E_OK E_NOT_OK	

Operation	Start	
Comment	–	
Mapped to API	Xxx_Start	
Variation	{ecuc(Dcm/DcmConfigSet/DcmDsp/DcmDspRoutine/DcmDspStartRoutine/DcmDspStartRoutineIn/DcmDspStartRoutineInSignal.DcmDspRoutineSignalType)} != VARIABLE_LENGTH) && {ecuc(Dcm/DcmConfigSet/DcmDsp/DcmDspRoutine/DcmDspStartRoutine/DcmDspStartRoutineOut/DcmDspStartRoutineOutSignal.DcmDspRoutineSignalType)} != VARIABLE_LENGTH)	
Parameters	DataIn_{Signal}	
	Type	Dcm_StartDataIn_{Routine}_{Signal}Type
	Direction	IN
	Comment	–
	Variation	Signal = {ecuc(Dcm/DcmConfigSet/DcmDsp/DcmDspRoutine/DcmDspStartRoutine/DcmDspStartRoutineIn/DcmDspStartRoutineInSignal.SHORT-NAME)} Routine = {ecuc(Dcm/DcmConfigSet/DcmDsp/DcmDspRoutine.SHORT-NAME)}
	OpStatus	
	Type	Dcm_OpStatusType
	Direction	IN
	Comment	–
	Variation	–
	DataOut_{Signal}	
	Type	Dcm_StartDataOut_{Routine}_{Signal}Type
	Direction	OUT
	Comment	–
	Variation	Signal = {ecuc(Dcm/DcmConfigSet/DcmDsp/DcmDspRoutine/DcmDspStartRoutine/DcmDspStartRoutineOut/DcmDspStartRoutineOutSignal.SHORT-NAME)} Routine = {ecuc(Dcm/DcmConfigSet/DcmDsp/DcmDspRoutine.SHORT-NAME)}
	ErrorCode	
Type	Dcm_NegativeResponseCodeType	
Direction	OUT	
Comment	–	
Variation	–	





Possible Errors	E_OK E_NOT_OK DCM_E_PENDING DCM_E_FORCE_RCRRP
------------------------	--

Operation	Start	
Comment	–	
Mapped to API	Xxx_Start	
Variation	(({ecuc(Dcm/DcmConfigSet/DcmDsp/DcmDspRoutine/DcmDspStartRoutine/DcmDspStartRoutineIn/DcmDspStartRoutineInSignal.DcmDspRoutineSignalType)} != VARIABLE_LENGTH) && ({ecuc(Dcm/DcmConfigSet/DcmDsp/DcmDspRoutine/DcmDspStartRoutine/DcmDspStartRoutineOut/DcmDspStartRoutineOutSignal.DcmDspRoutineSignalType)} == VARIABLE_LENGTH)	
Parameters	DataIn_{Signal}	
	Type	Dcm_StartDataIn_{Routine}_{Signal}Type
	Direction	IN
	Comment	–
	Variation	Routine = {ecuc(Dcm/DcmConfigSet/DcmDsp/DcmDspRoutine.SHORT-NAME)} Signal = {ecuc(Dcm/DcmConfigSet/DcmDsp/DcmDspRoutine/DcmDspStartRoutine/DcmDspStartRoutineIn/DcmDspStartRoutineInSignal.SHORT-NAME)}
	OpStatus	
	Type	Dcm_OpStatusType
	Direction	IN
	Comment	–
	Variation	–
	DataOut_{Signal}	
	Type	Dcm_StartDataOut_{Routine}_{Signal}Type
	Direction	OUT
	Comment	–
	Variation	Signal = {ecuc(Dcm/DcmConfigSet/DcmDsp/DcmDspRoutine/DcmDspStartRoutine/DcmDspStartRoutineOut/DcmDspStartRoutineOutSignal.SHORT-NAME)} Routine = {ecuc(Dcm/DcmConfigSet/DcmDsp/DcmDspRoutine.SHORT-NAME)}
	DataOut_{Signal}	
	Type	Dcm_StartFlexibleOutArrayData_{Routine}_{Signal}Type
	Direction	OUT
	Comment	–
	Variation	–
currentDataLength		
Type	uint16	
Direction	OUT	
Comment	–	
Variation	–	
ErrorCode		
Type	Dcm_NegativeResponseCodeType	
Direction	OUT	
Comment	–	





	Variation	–
Possible Errors	E_OK E_NOT_OK DCM_E_PENDING DCM_E_FORCE_RCRRP	

Operation	Start	
Comment	–	
Mapped to API	Xxx_Start	
Variation	({ecuc(Dcm/DcmConfigSet/DcmDsp/DcmDspRoutine/DcmDspStartRoutine/DcmDspStartRoutineIn/DcmDspStartRoutineInSignal.DcmDspRoutineSignalType)} == VARIABLE_LENGTH) && ({ecuc(Dcm/DcmConfigSet/DcmDsp/DcmDspRoutine/DcmDspStartRoutine/DcmDspStartRoutineOut/DcmDspStartRoutineOutSignal.DcmDspRoutineSignalType)} != VARIABLE_LENGTH)	
Parameters	DataIn_{Signal}	
	Type	Dcm_StartDataIn_{Routine}_{Signal}Type
	Direction	IN
	Comment	–
	Variation	Signal = {ecuc(Dcm/DcmConfigSet/DcmDsp/DcmDspRoutine/DcmDspStartRoutine/DcmDspStartRoutineIn/DcmDspStartRoutineInSignal.SHORT-NAME)} Routine = {ecuc(Dcm/DcmConfigSet/DcmDsp/DcmDspRoutine.SHORT-NAME)}
	DataIn_{Signal}	
	Type	Dcm_StartFlexibleInArrayData_{Routine}_{Signal}Type
	Direction	IN
	Comment	–
	Variation	–
	OpStatus	
	Type	Dcm_OpStatusType
	Direction	IN
	Comment	–
	Variation	–
	DataOut_{Signal}	
	Type	Dcm_StartDataOut_{Routine}_{Signal}Type
	Direction	OUT
	Comment	–
	Variation	Signal = {ecuc(Dcm/DcmConfigSet/DcmDsp/DcmDspRoutine/DcmDspStartRoutine/DcmDspStartRoutineOut/DcmDspStartRoutineOutSignal.SHORT-NAME)} Routine = {ecuc(Dcm/DcmConfigSet/DcmDsp/DcmDspRoutine.SHORT-NAME)}
currentDataLength		
Type	uint16	
Direction	IN	
Comment	–	
Variation	–	
ErrorCode		
Type	Dcm_NegativeResponseCodeType	
Direction	OUT	





	Comment	–
	Variation	–
Possible Errors	E_OK E_NOT_OK DCM_E_PENDING DCM_E_FORCE_RCRRP	

Operation	Start	
Comment	–	
Mapped to API	Xxx_Start	
Variation	({ecuc(Dcm/DcmConfigSet/DcmDsp/DcmDspRoutine/DcmDspStartRoutine/DcmDspStartRoutineIn/DcmDspStartRoutineInSignal.DcmDspRoutineSignalType)} == VARIABLE_LENGTH) && ({ecuc(Dcm/DcmConfigSet/DcmDsp/DcmDspRoutine/DcmDspStartRoutine/DcmDspStartRoutineOut/DcmDspStartRoutineOutSignal.DcmDspRoutineSignalType)} == VARIABLE_LENGTH)	
Parameters	DataIn_{Signal}	
	Type	Dcm_StartDataIn_{Routine}_{Signal}Type
	Direction	IN
	Comment	–
	Variation	{ecuc(Dcm/DcmConfigSet/DcmDsp/DcmDspRoutine/DcmDspStartRoutine/DcmDspStartRoutineIn/DcmDspStartRoutineInSignal.DcmDspRoutineSignalType)} != VARIABLE_LENGTH Signal = {ecuc(Dcm/DcmConfigSet/DcmDsp/DcmDspRoutine/DcmDspStartRoutine/DcmDspStartRoutineIn/DcmDspStartRoutineInSignal.SHORT-NAME)} Routine = {ecuc(Dcm/DcmConfigSet/DcmDsp/DcmDspRoutine.SHORT-NAME)}
	DataIn_{Signal}	
	Type	Dcm_StartFlexibleInArrayData_{Routine}_{Signal}Type
	Direction	IN
	Comment	–
	Variation	{ecuc(Dcm/DcmConfigSet/DcmDsp/DcmDspRoutine/DcmDspStartRoutine/DcmDspStartRoutineIn/DcmDspStartRoutineInSignal.DcmDspRoutineSignalType)} == VARIABLE_LENGTH Signal = {ecuc(Dcm/DcmConfigSet/DcmDsp/DcmDspRoutine/DcmDspStartRoutine/DcmDspStartRoutineIn/DcmDspStartRoutineInSignal.SHORT-NAME)} Routine = {ecuc(Dcm/DcmConfigSet/DcmDsp/DcmDspRoutine.SHORT-NAME)}
	OpStatus	
	Type	Dcm_OpStatusType
	Direction	IN
	Comment	–
	Variation	–
	DataOut_{Signal}	
Type	Dcm_StartDataOut_{Routine}_{Signal}Type	
Direction	OUT	
Comment	–	





	Variation	{ecuc(Dcm/DcmConfigSet/DcmDsp/DcmDspRoutine/DcmDspStartRoutine/DcmDspStartRoutineOut/DcmDspStartRoutineOutSignal.DcmDspRoutineSignalType)} != VARIABLE_LENGTH Signal = {ecuc(Dcm/DcmConfigSet/DcmDsp/DcmDspRoutine/DcmDspStartRoutine/DcmDspStartRoutineOut/DcmDspStartRoutineOutSignal.SHORT-NAME)} Routine = {ecuc(Dcm/DcmConfigSet/DcmDsp/DcmDspRoutine.SHORT-NAME)}
	DataOut_{Signal}	
	Type	Dcm_StartFlexibleOutArrayData_{Routine}_{Signal}Type
	Direction	OUT
	Comment	–
	Variation	{ecuc(Dcm/DcmConfigSet/DcmDsp/DcmDspRoutine/DcmDspStartRoutine/DcmDspStartRoutineOut/DcmDspStartRoutineOutSignal.DcmDspRoutineSignalType)} == VARIABLE_LENGTH Signal = {ecuc(Dcm/DcmConfigSet/DcmDsp/DcmDspRoutine/DcmDspStartRoutine/DcmDspStartRoutineOut/DcmDspStartRoutineOutSignal.SHORT-NAME)} Routine = {ecuc(Dcm/DcmConfigSet/DcmDsp/DcmDspRoutine.SHORT-NAME)}
	currentDataLength	
	Type	uint16
	Direction	INOUT
	Comment	–
	Variation	–
	ErrorCode	
	Type	Dcm_NegativeResponseCodeType
	Direction	OUT
	Comment	–
	Variation	–
Possible Errors	E_OK E_NOT_OK DCM_E_PENDING DCM_E_FORCE_RCRRP	

Operation	StartConfirmation	
Comment	This operation indicates the transmission of a response to a StartRoutine request	
Mapped to API	Xxx_StartConfirmation	
Variation	{ecuc(Dcm/DcmConfigSet/DcmDsp/DcmDspRoutine/DcmDspStartRoutine/DcmDspStartRoutineConfirmationEnabled)}==TRUE	
Parameters	ConfirmationStatus	
	Type	Dcm_ConfirmationStatusType
	Direction	IN
	Comment	Confirmation status of a StartRoutine request
	Variation	–
Possible Errors	E_OK E_NOT_OK	

Operation	Stop
Comment	–
Mapped to API	Xxx_Stop





Variation	({ecuc(Dcm/DcmConfigSet/DcmDsp/DcmDspRoutine/DcmDspStopRoutine/DcmDspStopRoutineIn/DcmDspStopRoutineInSignal.DcmDspRoutineSignalType)} != VARIABLE_LENGTH) && ({ecuc(Dcm/DcmConfigSet/DcmDsp/DcmDspRoutine/DcmDspStopRoutine/DcmDspStopRoutineOut/DcmDspStopRoutineOutSignal.DcmDspRoutineSignalType)} != VARIABLE_LENGTH)		
Parameters	DataIn_{Signal}		
	Type	Dcm_StopDataIn_{Routine}_{Signal}Type	
	Direction	IN	
	Comment	–	
	Variation	Signal = {ecuc(Dcm/DcmConfigSet/DcmDsp/DcmDspRoutine/DcmDspStopRoutine/DcmDspStopRoutineIn/DcmDspStopRoutineInSignal.SHORT-NAME)} Routine = {ecuc(Dcm/DcmConfigSet/DcmDsp/DcmDspRoutine.SHORT-NAME)}	
	OpStatus		
	Type	Dcm_OpStatusType	
	Direction	IN	
	Comment	–	
	Variation	–	
	DataOut_{Signal}		
	Type	Dcm_StopDataOut_{Routine}_{Signal}Type	
	Direction	OUT	
	Comment	–	
Variation	Signal = {ecuc(Dcm/DcmConfigSet/DcmDsp/DcmDspRoutine/DcmDspStopRoutine/DcmDspStopRoutineOut/DcmDspStopRoutineOutSignal.SHORT-NAME)} Routine = {ecuc(Dcm/DcmConfigSet/DcmDsp/DcmDspRoutine.SHORT-NAME)}		
ErrorCode			
Type	Dcm_NegativeResponseCodeType		
Direction	OUT		
Comment	–		
Variation	–		
Possible Errors	E_OK E_NOT_OK DCM_E_PENDING DCM_E_FORCE_RCRPP		

Operation	Stop	
Comment	–	
Mapped to API	Xxx_Stop	
Variation	({ecuc(Dcm/DcmConfigSet/DcmDsp/DcmDspRoutine/DcmDspStopRoutine/DcmDspStopRoutineIn/DcmDspStopRoutineInSignal.DcmDspRoutineSignalType)} != VARIABLE_LENGTH) && ({ecuc(Dcm/DcmConfigSet/DcmDsp/DcmDspRoutine/DcmDspStopRoutine/DcmDspStopRoutineOut/DcmDspStopRoutineOutSignal.DcmDspRoutineSignalType)} == VARIABLE_LENGTH)	
Parameters	DataIn_{Signal}	
	Type	Dcm_StopDataIn_{Routine}_{Signal}Type
	Direction	IN
	Comment	–





	Variation	Signal = {ecuc(Dcm/DcmConfigSet/DcmDsp/DcmDspRoutine/DcmDspStopRoutine/DcmDspStopRoutineIn/DcmDspStopRoutineInSignal.SHORT-NAME)} Routine = {ecuc(Dcm/DcmConfigSet/DcmDsp/DcmDspRoutine.SHORT-NAME)}
	OpStatus	
	Type	Dcm_OpStatusType
	Direction	IN
	Comment	–
	Variation	–
	DataOut_{Signal}	
	Type	Dcm_StopDataOut_{Routine}_{Signal}Type
	Direction	OUT
	Comment	–
	Variation	Signal = {ecuc(Dcm/DcmConfigSet/DcmDsp/DcmDspRoutine/DcmDspStopRoutine/DcmDspStopRoutineOut/DcmDspStopRoutineOutSignal.SHORT-NAME)} Routine = {ecuc(Dcm/DcmConfigSet/DcmDsp/DcmDspRoutine.SHORT-NAME)}
	DataOut_{Signal}	
	Type	Dcm_StopFlexibleOutArrayData_{Routine}_{Signal}Type
	Direction	OUT
	Comment	–
	Variation	–
	currentDataLength	
	Type	uint16
	Direction	OUT
	Comment	–
	Variation	–
	ErrorCode	
	Type	Dcm_NegativeResponseCodeType
	Direction	OUT
	Comment	–
	Variation	–
Possible Errors	E_OK E_NOT_OK DCM_E_PENDING DCM_E_FORCE_RCRFP	

Operation	Stop	
Comment	–	
Mapped to API	Xxx_Stop	
Variation	((ecuc(Dcm/DcmConfigSet/DcmDsp/DcmDspRoutine/DcmDspStopRoutine/DcmDspStopRoutineIn/DcmDspStopRoutineInSignal.DcmDspRoutineSignalType)) == VARIABLE_LENGTH) && ((ecuc(Dcm/DcmConfigSet/DcmDsp/DcmDspRoutine/DcmDspStopRoutine/DcmDspStopRoutineOut/DcmDspStopRoutineOutSignal.DcmDspRoutineSignalType)) != VARIABLE_LENGTH)	
Parameters	DataIn_{Signal}	
	Type	Dcm_StopDataIn_{Routine}_{Signal}Type
	Direction	IN





	Comment	–
	Variation	Signal = {ecuc(Dcm/DcmConfigSet/DcmDsp/DcmDspRoutine/DcmDspStopRoutine/DcmDspStopRoutineIn/DcmDspStopRoutineInSignal.SHORT-NAME)} Routine = {ecuc(Dcm/DcmConfigSet/DcmDsp/DcmDspRoutine.SHORT-NAME)}
	DataIn_{Signal}	
	Type	Dcm_StopFlexibleInArrayData_{Routine}_{Signal}Type
	Direction	IN
	Comment	–
	Variation	–
	OpStatus	
	Type	Dcm_OpStatusType
	Direction	IN
	Comment	–
	Variation	–
	DataOut_{Signal}	
	Type	Dcm_StopDataOut_{Routine}_{Signal}Type
	Direction	OUT
	Comment	–
	Variation	Signal = {ecuc(Dcm/DcmConfigSet/DcmDsp/DcmDspRoutine/DcmDspStopRoutine/DcmDspStopRoutineOut/DcmDspStopRoutineOutSignal.SHORT-NAME)} Routine = {ecuc(Dcm/DcmConfigSet/DcmDsp/DcmDspRoutine.SHORT-NAME)}
	currentDataLength	
	Type	uint16
	Direction	IN
	Comment	–
	Variation	–
	ErrorCode	
	Type	Dcm_NegativeResponseCodeType
	Direction	OUT
	Comment	–
	Variation	–
Possible Errors	E_OK E_NOT_OK DCM_E_PENDING DCM_E_FORCE_RCRRP	

Operation	Stop
Comment	–
Mapped to API	Xxx_Stop
Variation	{ecuc(Dcm/DcmConfigSet/DcmDsp/DcmDspRoutine/DcmDspStopRoutine/DcmDspStopRoutineIn/DcmDspStopRoutineInSignal.DcmDspRoutineSignalType)} == VARIABLE_LENGTH) && {ecuc(Dcm/DcmConfigSet/DcmDsp/DcmDspRoutine/DcmDspStopRoutine/DcmDspStopRoutineOut/DcmDspStopRoutineOutSignal.DcmDspRoutineSignalType)} == VARIABLE_LENGTH)
Parameters	DataIn_{Signal}
	Type Dcm_StopDataIn_{Routine}_{Signal}Type





Direction	IN
Comment	–
Variation	{ecuc(Dcm/DcmConfigSet/DcmDsp/DcmDspRoutine/DcmDspStopRoutine/DcmDspStopRoutineIn/DcmDspStopRoutineInSignal.DcmDspRoutineSignalType)} != VARIABLE_LENGTH Signal = {ecuc(Dcm/DcmConfigSet/DcmDsp/DcmDspRoutine/DcmDspStopRoutine/DcmDspStopRoutineIn/DcmDspStopRoutineInSignal.SHORT-NAME)} Routine = {ecuc(Dcm/DcmConfigSet/DcmDsp/DcmDspRoutine.SHORT-NAME)}
DataIn_{Signal}	
Type	Dcm_StopFlexibleInArrayData_{Routine}_{Signal}Type
Direction	IN
Comment	–
Variation	{ecuc(Dcm/DcmConfigSet/DcmDsp/DcmDspRoutine/DcmDspStopRoutine/DcmDspStopRoutineIn/DcmDspStopRoutineInSignal.DcmDspRoutineSignalType)} == VARIABLE_LENGTH Signal = {ecuc(Dcm/DcmConfigSet/DcmDsp/DcmDspRoutine/DcmDspStopRoutine/DcmDspStopRoutineIn/DcmDspStopRoutineInSignal.SHORT-NAME)} Routine = {ecuc(Dcm/DcmConfigSet/DcmDsp/DcmDspRoutine.SHORT-NAME)}
OpStatus	
Type	Dcm_OpStatusType
Direction	IN
Comment	–
Variation	–
DataOut_{Signal}	
Type	Dcm_StopDataOut_{Routine}_{Signal}Type
Direction	OUT
Comment	–
Variation	{ecuc(Dcm/DcmConfigSet/DcmDsp/DcmDspRoutine/DcmDspStopRoutine/DcmDspStopRoutineOut/DcmDspStopRoutineOutSignal.DcmDspRoutineSignalType)} != VARIABLE_LENGTH Signal = {ecuc(Dcm/DcmConfigSet/DcmDsp/DcmDspRoutine/DcmDspStopRoutine/DcmDspStopRoutineOut/DcmDspStopRoutineOutSignal.SHORT-NAME)} Routine = {ecuc(Dcm/DcmConfigSet/DcmDsp/DcmDspRoutine.SHORT-NAME)}
DataOut_{Signal}	
Type	Dcm_StopFlexibleOutArrayData_{Routine}_{Signal}Type
Direction	OUT
Comment	–
Variation	{ecuc(Dcm/DcmConfigSet/DcmDsp/DcmDspRoutine/DcmDspStopRoutine/DcmDspStopRoutineOut/DcmDspStopRoutineOutSignal.DcmDspRoutineSignalType)} == VARIABLE_LENGTH Signal = {ecuc(Dcm/DcmConfigSet/DcmDsp/DcmDspRoutine/DcmDspStopRoutine/DcmDspStopRoutineOut/DcmDspStopRoutineOutSignal.SHORT-NAME)} Routine = {ecuc(Dcm/DcmConfigSet/DcmDsp/DcmDspRoutine.SHORT-NAME)}
currentDataLength	
Type	uint16
Direction	INOUT
Comment	–
Variation	–
ErrorCode	





	Type	Dcm_NegativeResponseCodeType
	Direction	OUT
	Comment	–
	Variation	–
Possible Errors	E_OK E_NOT_OK DCM_E_PENDING DCM_E_FORCE_RCRFP	

Operation	StopConfirmation	
Comment	This operation indicates the transmission of a response to a StopRoutine request	
Mapped to API	Xxx_StopConfirmation	
Variation	({ecuc(Dcm/DcmConfigSet/DcmDsp/DcmDspRoutine/DcmDspStopRoutine/DcmDspStopRoutineConfirmationEnabled)}==TRUE)	
Parameters	ConfirmationStatus	
	Type	Dcm_ConfirmationStatusType
	Direction	IN
	Comment	Confirmation status of a StopRoutine request
	Variation	–
Possible Errors	E_OK E_NOT_OK	

E.3.4.3 ServiceRequestNotification

The following interface indicates to the Application that a service is about to be executed and allows the Application to reject the execution of the service request.

Name	ServiceRequestNotification		
Comment	–		
IsService	true		
Variation	({ecuc(Dcm/DcmConfigSet/DcmDsd/DcmDsdServiceRequestManufacturerNotification)} != NULL) ({ecuc(Dcm/DcmConfigSet/DcmDsd/DcmDsdServiceRequestSupplierNotification)} != NULL)		
Possible Errors	0	E_OK	Operation successful
	1	E_NOT_OK	Operation failed
	8	E_REQUEST_NOT_ACCEPTED	no response will be sent

Operation	Confirmation	
Comment	–	
Mapped to API	Xxx_Confirmation	
Variation	–	
Parameters	SID	
	Type	uint8
	Direction	IN
	Comment	Value of service identifier
	Variation	–





	ReqType	
	Type	uint8
	Direction	IN
	Comment	Addressing type of the request(0=physical request, 1=functional request)
	Variation	–
	ConnectionId	
	Type	uint16
	Direction	IN
	Comment	Unique connection identifier
	Variation	–
	ConfirmationStatus	
	Type	Dcm_ConfirmationStatusType
	Direction	IN
	Comment	Confirmation of a successful transmission or a transmission error of a diagnostic service.
	Variation	–
	ProtocolType	
	Type	Dcm_ProtocolType
	Direction	IN
	Comment	–
	Variation	–
TesterSourceAddress		
Type	uint16	
Direction	IN	
Comment	–	
Variation	–	
Possible Errors	E_OK E_NOT_OK	

Operation	Indication	
Comment	–	
Mapped to API	Xxx_Indication	
Variation	–	
Parameters	SID	
	Type	uint8
	Direction	IN
	Comment	Value of service identifier
	Variation	–
	RequestData	
	Type	Dcm_RequestDataArrayType
	Direction	IN
	Comment	This parameter contains the complete request data (diagnostic buffer), except the service ID
	Variation	–
DataSize		
Type	uint32	
Direction	IN	





	Comment	This parameter defines how many bytes in the RequestData parameter are valid	
	Variation	–	
	ReqType		
	Type	uint8	
	Direction	IN	
	Comment	Addressing type of the request(0=physical request, 1=functional request)	
	Variation	–	
	ConnectionId		
	Type	uint16	
	Direction	IN	
	Comment	Unique connection identifier	
	Variation	–	
	ErrorCode		
	Type	Dcm_NegativeResponseCodeType	
	Direction	OUT	
	Comment	–	
	Variation	–	
	ProtocolType		
	Type	Dcm_ProtocolType	
	Direction	IN	
	Comment	–	
	Variation	–	
	TesterSourceAddress		
	Type	uint16	
	Direction	IN	
	Comment	–	
	Variation	–	
Possible Errors	E_OK E_NOT_OK E_REQUEST_NOT_ACCEPTED		

E.3.5 Ports

E.3.5.1 DataServices_{DID} RPortProtype

Name	DataServices_{DID}		
Kind	RequiredPort	Interface	DataServices_{DID} , DataServices_{DID}
Description	–		





Variation	<pre> ((ecuc(Dcm/DcmConfigSet/DcmDsp/DcmDspDid/DcmDspDidUsePort)) == (USE_ATOMIC_SENDER_RECEIVER_INTERFACE) (ecuc(Dcm/DcmConfigSet/DcmDsp/DcmDspDid/DcmDspDidUsePort)) == (USE_ATOMIC_SENDER_RECEIVER_INTERFACE_AS_SERVICE) (ecuc(Dcm/DcmConfigSet/DcmDsp/DcmDspDid/DcmDspDidUsePort)) == (USE_ATOMIC_NV_DATA_INTERFACE)) && (ecuc(Dcm/DcmConfigSet/DcmDsp/DcmDspDid/DcmDspDidInfoRef->DcmDspDidInfo/DcmDspDidWrite)) == NULL && ((ecuc(Dcm/DcmConfigSet/DcmDsp/DcmDspDid/DcmDspDidInfoRef->DcmDspDidInfo/DcmDspDidRead)) != NULL (ecuc(Dcm/DcmConfigSet/DcmDsp/DcmDspDid/DcmDspDidInfoRef->DcmDspDidInfo/DcmDspDidControl)) !=NULL)) DID = {ecuc(Dcm/DcmConfigSet/DcmDsp/DcmDspDid.SHORT-NAME)} </pre>
------------------	---

E.3.5.2 DataServices_{DID} PPortProtyope

Name	DataServices_{DID}		
Kind	ProvidedPort	Interface	DataServices_{DID}, DataServices_{DID}
Description	-		
Variation	<pre> ((ecuc(Dcm/DcmConfigSet/DcmDsp/DcmDspDid/DcmDspDidUsePort)) == (USE_ATOMIC_SENDER_RECEIVER_INTERFACE) (ecuc(Dcm/DcmConfigSet/DcmDsp/DcmDspDid/DcmDspDidUsePort)) == (USE_ATOMIC_SENDER_RECEIVER_INTERFACE_AS_SERVICE) (ecuc(Dcm/DcmConfigSet/DcmDsp/DcmDspDid/DcmDspDidUsePort)) == (USE_ATOMIC_NV_DATA_INTERFACE)) && (ecuc(Dcm/DcmConfigSet/DcmDsp/DcmDspDid/DcmDspDidInfoRef->DcmDspDidInfo/DcmDspDidWrite)) != NULL && ((ecuc(Dcm/DcmConfigSet/DcmDsp/DcmDspDid/DcmDspDidInfoRef->DcmDspDidInfo/DcmDspDidRead)) == NULL (ecuc(Dcm/DcmConfigSet/DcmDsp/DcmDspDid/DcmDspDidInfoRef->DcmDspDidInfo/DcmDspDidControl)) !=NULL)) DID = {ecuc(Dcm/DcmConfigSet/DcmDsp/DcmDspDid.SHORT-NAME)} </pre>		

E.3.5.3 DataServices_{DID} PRPortProtyope

Name	DataServices_{DID}		
Kind	Provided RequiredPort	Interface	DataServices_{DID}, DataServices_{DID}
Description	-		
Variation	<pre> ((ecuc(Dcm/DcmConfigSet/DcmDsp/DcmDspDid/DcmDspDidUsePort)) == (USE_ATOMIC_SENDER_RECEIVER_INTERFACE) (ecuc(Dcm/DcmConfigSet/DcmDsp/DcmDspDid/DcmDspDidUsePort)) == (USE_ATOMIC_SENDER_RECEIVER_INTERFACE_AS_SERVICE) (ecuc(Dcm/DcmConfigSet/DcmDsp/DcmDspDid/DcmDspDidUsePort)) == (USE_ATOMIC_NV_DATA_INTERFACE)) && (ecuc(Dcm/DcmConfigSet/DcmDsp/DcmDspDid/DcmDspDidInfoRef->DcmDspDidInfo/DcmDspDidWrite)) != NULL && (ecuc(Dcm/DcmConfigSet/DcmDsp/DcmDspDid/DcmDspDidInfoRef->DcmDspDidInfo/DcmDspDidRead)) != NULL) DID = {ecuc(Dcm/DcmConfigSet/DcmDsp/DcmDspDid.SHORT-NAME)} </pre>		

E.3.5.4 DataServices_{Data} RPortProtyope

Name	DataServices_{Data}		
Kind	RequiredPort	Interface	DataServices_{Data}, DataServices_{Data}
Description	–		
Variation	<pre>({ecuc(Dcm/DcmConfigSet/DcmDsp/DcmDspPid/DcmDspPidData/DcmDspPidService01/DcmDspPidDataUsePort)} == (USE_DATA_SYNCH_CLIENT_SERVER USE_DATA_SENDER_RECEIVER USE_DATA_SENDER_RECEIVER_AS_SERVICE)) Data = {ecuc(Dcm/DcmConfigSet/DcmDsp/DcmDspData.SHORT-NAME)} {ecuc(Dcm/DcmConfigSet/DcmDsp/DcmDspPid/DcmDspPidData.SHORT-NAME)}</pre>		

E.3.5.5 DataServices_{Data} RPortProtyope

Name	DataServices_{Data}		
Kind	RequiredPort	Interface	DataServices_{Data}, DataServices_{Data}
Description	–		
Variation	<pre>(({ecuc(Dcm/DcmConfigSet/DcmDsp/DcmDspDid/DcmDspDidUsePort)} == USE_DATA_ELEMENT_SPECIFIC_INTERFACES) && ({ecuc(Dcm/DcmConfigSet/DcmDsp/DcmDspData/DcmDspDataUsePort)} == (USE_DATA_SENDER_RECEIVER USE_DATA_SENDER_RECEIVER_AS_SERVICE)) && ({ecuc(Dcm/DcmConfigSet/DcmDsp/DcmDspDid/DcmDspDidInfoRef-> DcmDspDidInfo/DcmDspDidWrite)} == NULL) && (({ecuc(Dcm/DcmConfigSet/DcmDsp/DcmDspDid/DcmDspDidInfoRef-> DcmDspDidInfo/DcmDspDidRead)} != NULL))) Data = {ecuc(Dcm/DcmConfigSet/DcmDsp/DcmDspData.SHORT-NAME)}</pre>		

E.3.5.6 DataServices_{Data} PPortProtyope

Name	DataServices_{Data}		
Kind	ProvidedPort	Interface	DataServices_{Data}, DataServices_{Data}
Description	–		
Variation	<pre>(({ecuc(Dcm/DcmConfigSet/DcmDsp/DcmDspDid/DcmDspDidUsePort)} == USE_DATA_ELEMENT_SPECIFIC_INTERFACES) && ({ecuc(Dcm/DcmConfigSet/DcmDsp/DcmDspData/DcmDspDataUsePort)} == (USE_DATA_SENDER_RECEIVER USE_DATA_SENDER_RECEIVER_AS_SERVICE)) && ({ecuc(Dcm/DcmConfigSet/DcmDsp/DcmDspDid/DcmDspDidInfoRef-> DcmDspDidInfo/DcmDspDidWrite)} != NULL) && ({ecuc(Dcm/DcmConfigSet/DcmDsp/DcmDspDid/DcmDspDidInfoRef-> DcmDspDidInfo/DcmDspDidRead)} == NULL) Data = {ecuc(Dcm/DcmConfigSet/DcmDsp/DcmDspData.SHORT-NAME)}</pre>		

E.3.5.7 DataServices_{Data} PRPortProtyope

Name	DataServices_{Data}		
Kind	Provided RequiredPort	Interface	DataServices_{Data}





Description	–
Variation	((({ecuc(Dcm/DcmConfigSet/DcmDsp/DcmDspDid/DcmDspDidUsePort)} == USE_DATA_ELEMENT_SPECIFIC_INTERFACES)) && ({ecuc(Dcm/DcmConfigSet/DcmDsp/DcmDspData/DcmDspDataUsePort)} == (USE_DATA_SENDER_RECEIVER USE_DATA_SENDER_RECEIVER_AS_SERVICE))) && ({ecuc(Dcm/DcmConfigSet/DcmDsp/DcmDspDid/DcmDspDidInfoRef-> DcmDspDidInfo/DcmDspDidWrite)} != NULL) && ({ecuc(Dcm/DcmConfigSet/DcmDsp/DcmDspDid/DcmDspDidInfoRef-> DcmDspDidInfo/DcmDspDidRead)} != NULL) Data = {ecuc(Dcm/DcmConfigSet/DcmDsp/DcmDspData.SHORT-NAME)}

E.3.5.8 IOControlRequest_{DID}

Name	IOControlRequest_{DID}		
Kind	Provided RequiredPort	Interface	IOControlRequest_{DID}
Description	–		
Variation	(((ecuc(Dcm/DcmConfigSet/DcmDsp/DcmDspDid/DcmDspDidUsePort)} == (USE_ATOMIC_SENDER_RECEIVER_INTERFACE USE_ATOMIC_SENDER_RECEIVER_INTERFACE_AS_SERVICE))) && ({ecuc(Dcm/DcmConfigSet/DcmDsp/DcmDspDid/DcmDspDidInfoRef-> DcmDspDidInfo/DcmDspDidControl)} != NULL) DID = ({ecuc(Dcm/DcmConfigSet/DcmDsp/DcmDspDid.SHORT-NAME)})		

E.3.5.9 IOControlResponse_{DID}

Name	IOControlResponse_{DID}		
Kind	RequiredPort	Interface	IOControlResponse_{DID}
Description	–		
Variation	(((ecuc(Dcm/DcmConfigSet/DcmDsp/DcmDspDid/DcmDspDidUsePort)} == (USE_ATOMIC_SENDER_RECEIVER_INTERFACE USE_ATOMIC_SENDER_RECEIVER_INTERFACE_AS_SERVICE))) && ({ecuc(Dcm/DcmConfigSet/DcmDsp/DcmDspDid/DcmDspDidInfoRef-> DcmDspDidInfo/DcmDspDidControl)} != NULL) DID = ({ecuc(Dcm/DcmConfigSet/DcmDsp/DcmDspDid.SHORT-NAME)})		

E.3.5.10 ServiceRequestManufacturerNotification_{Name}

Name	ServiceRequestManufacturerNotification_{Name}		
Kind	RequiredPort	Interface	ServiceRequestNotification
Description	–		
Variation	({ecuc(Dcm/DcmConfigSet/DcmDsd/DcmDsdServiceRequestManufacturerNotification)} != NULL) Name = {ecuc(Dcm/DcmConfigSet/DcmDsd/DcmDsdServiceRequestManufacturerNotification.SHORT-NAME)}		

E.3.5.11 ServiceRequestSupplierNotification_{Name}

Name	ServiceRequestSupplierNotification_{Name}		
Kind	RequiredPort	Interface	ServiceRequestNotification
Description	–		
Variation	({ecuc(Dcm/DcmConfigSet/DcmDsd/DcmDsdServiceRequestSupplierNotification)} != NULL) Name = {ecuc(Dcm/DcmConfigSet/DcmDsd/DcmDsdServiceRequestSupplierNotification.SHORT-NAME)}		

E.3.5.12 RoutineServices_{RoutineName}

Name	RoutineServices_{RoutineName}		
Kind	RequiredPort	Interface	RoutineServices_{RoutineName}
Description	–		
Variation	{ecuc(Dcm/DcmConfigSet/DcmDsp/DcmDspRoutine.DcmDspRoutineUsePort)} == TRUE RoutineName = {ecuc(Dcm/DcmConfigSet/DcmDsp/DcmDspRoutine.SHORT-NAME)}		

E.4 Dem

E.4.1 Implementation Data Types

E.4.1.1 Dem_DebouncingStateType

Name	Dem_DebouncingStateType			
Kind	Bitfield			
Derived from	uint8			
Elements	Kind	Name	Mask	Description
	bit	DEM_TEMPORARILY_DEFECTIVE	0x01	Bit 0: Temporarily Defective (corresponds to 0 < FDC < 127)
	bit	DEM_FINALLY_DEFECTIVE	0x02	Bit 1: finally Defective (corresponds to FDC = 127)
	bit	DEM_TEMPORARILY_HEALED	0x04	Bit 2: temporarily healed (corresponds to -128 < FDC < 0)
	bit	DEM_TEST_COMPLETE	0x08	Bit 3: Test complete (corresponds to FDC = -128 or FDC = 127)
	bit	DEM_DTR_UPDATE	0x10	Bit 4: DTR Update (= Test complete && Debouncing complete && enable conditions / storage conditions fulfilled)
Description	–			
Variation	–			
Available via	Rte_Dem_Type.h			

E.4.1.2 Dem_DTCOriginType

Name	Dem_DTCOriginType		
Kind	Type		
Derived from	uint16		
Range	DEM_DTC_ORIGIN_PRIMARY_MEMORY	0x0001	Event information located in the primary memory
	DEM_DTC_ORIGIN_PERMANENT_MEMORY	0x0003	The Event information is located in the permanent memory
	DEM_DTC_ORIGIN_OBD_RELEVANT_MEMORY	0x0004	OBD event information located in the primary memory.
	DEM_DTC_ORIGIN_USERDEFINED_MEMORY_<Name>	0x01XX	Event information located in the user defined memory, where XX is the configured DemUserDefinedMemoryIdentifier in hexadecimal and <Name> is the Short-Name of the DemUserDefinedMemory.
Description	This enum is used to define the location of the events. The definition and use of the different memory types is OEM-specific.		
Variation	–		
Available via	Rte_Dem_Type.h		

E.4.1.3 Dem_EventIdType

Name	Dem_EventIdType		
Kind	Type		
Derived from	uint16		
Range	1..65535	–	Internal identifier of a diagnostic event Remark: 0 is not a valid value
Description	Identification of an event by assigned EventId. The EventId is assigned by the Dem. Example: 1 refers to monitor x, 2 refers to monitor y, etc.		
Variation	–		
Available via	Rte_Dem_Type.h		

E.4.1.4 Dem_EventStatusType

Name	Dem_EventStatusType		
Kind	Type		
Derived from	uint8		
Range	DEM_EVENT_STATUS_PASSED	0x00	Monitor reports qualified test result passed.
	DEM_EVENT_STATUS_FAILED	0x01	Monitor reports qualified test result failed.





	DEM_EVENT_STATUS_PREPASSED	0x02	Monitor reports non-qualified test result pre-passed (debounced Dem-internally).
	DEM_EVENT_STATUS_PREFAILED	0x03	Monitor reports non-qualified test result pre-failed (debounced Dem-internally).
	DEM_EVENT_STATUS_FDC_THRESHOLD_REACHED	0x04	Monitor triggers the storage of ExtendedDataRecords and FreezeFrames ON_FDC_THRESHOLD.
		0x05 - 0xFF	reserved
Description	This type contains all monitor test result values, which can be reported via Dem_SetEventStatus().		
Variation	–		
Available via	Rte_Dem_Type.h		

E.4.1.5 Dem_DebounceResetStatusType

Name	Dem_DebounceResetStatusType		
Kind	Type		
Derived from	uint8		
Range	DEM_DEBOUNCE_STATUS_FREEZE	0x00	Freeze the internal debounce counter/timer.
	DEM_DEBOUNCE_STATUS_RESET	0x01	Reset the internal debounce counter/timer.
		0x02 - 0xFF	reserved
Description	This type contains all definitions to control an internal debounce counter/timer via the function Dem_ResetEventDebounceStatus().		
Variation	–		
Available via	Rte_Dem_Type.h		

E.4.1.6 Dem_DTCFormatType

Name	Dem_DTCFormatType		
Kind	Type		
Derived from	uint8		
Range	DEM_DTC_FORMAT_OBD	0	selects the 2-byte OBD DTC format (refer to configuration parameter DemObdDTC)
	DEM_DTC_FORMAT_UDS	1	selects the 3-byte UDS DTC format (refer to configuration parameter DemUdsDTC)
	DEM_DTC_FORMAT_J1939	2	selects the merged SPN + FMI to 3-byte J1939 DTC format (refer to DemJ1939DTC)





	DEM_DTC_FORMAT_OBD_3BYTE	3	Selects the 3-byte OBD DTC defined by DemDtcValue3Byte in case that SAE J2012 and UDS DTC format separation is used.
Description	This type is used to select the format of the DTC value.		
Variation	–		
Available via	Rte_Dem_Type.h		

E.4.1.7 Dem_InitMonitorReasonType

Name	Dem_InitMonitorReasonType		
Kind	Type		
Derived from	uint8		
Range	DEM_INIT_MONITOR_CLEAR	0x01	Event was cleared and all internal values and states are reset.
	DEM_INIT_MONITOR_RESTART	0x02	Operation cycle of the event was restarted.
	DEM_INIT_MONITOR_REENABLED	0x03	Enable conditions or DTC settings re-enabled.
	DEM_INIT_MONITOR_STORAGE_REENABLED	0x04	Storage condition reenabled.
Description	(Re-)Initialization reason returned by the callback <Module>_DemInitMonitorFor<EventName>().		
Variation	–		
Available via	Rte_Dem_Type.h		

E.4.1.8 Dem_MaxDataValueType

Name	Dem_MaxDataValueType		
Kind	Array	Element type	uint8
Size	size of largest Extended data class / Freeze frame record Elements		
Description	–		
Variation	–		
Available via	Rte_Dem_Type.h		

E.4.1.9 Dem_MonitorDataType

Name	Dem_MonitorDataType		
Kind	Type		
Derived from	uint32		





Description	This type is used to pass monitoring data to the Dem.
Variation	–
Available via	Rte_Dem_Type.h

E.4.1.10 Dem_MonitorStatusType

Name	Dem_MonitorStatusType			
Kind	Bitfield			
Derived from	uint8			
Elements	Kind	Name	Mask	Description
	bit	DEM_MONITOR_STATUS_TF	0x01	Bit0: TestFailed
	bit	DEM_MONITOR_STATUS_TNCTOC	0x02	Bit1: TestNotCompletedThis OperationCycle
Description	This type contains possible monitor status values.			
Variation	–			
Available via	Rte_Dem_Type.h			

E.4.1.11 Dem_UdsStatusByteType

Name	Dem_UdsStatusByteType			
Kind	Bitfield			
Derived from	uint8			
Lower limit	0x00			
Upper limit	0xFF			
Elements	Kind	Name	Mask	Description
	bit	DEM_UDS_STATUS_TF	0x01	bit 0: TestFailed
	bit	DEM_UDS_STATUS_TFTOC	0x02	bit 1: TestFailedThisOperation Cycle
	bit	DEM_UDS_STATUS_PDTC	0x04	bit 2: PendingDTC
	bit	DEM_UDS_STATUS_CDTC	0x08	bit 3: ConfirmedDTC
	bit	DEM_UDS_STATUS_TNCSLC	0x10	bit 4: TestNotCompletedSince LastClear
	bit	DEM_UDS_STATUS_TFSLC	0x20	bit 5: TestFailedSinceLastClear
	bit	DEM_UDS_STATUS_TNCTOC	0x40	bit 6: TestNotCompletedThis OperationCycle
bit	DEM_UDS_STATUS_WIR	0x80	bit 7: WarningIndicator Requested	
Description	In this data-type each bit has an individual meaning. The bit is set to 1 when the condition holds. For example, if the 2nd bit (0x02) is set to 1, this means that the test failed this operation cycle. If the bit is set to 0, it has not yet failed this cycle.			
Variation	–			
Available via	Rte_Dem_Type.h			

E.4.2 Client-Server-Interfaces

E.4.2.1 CallbackClearEventAllowed

Name	CallbackClearEventAllowed		
Comment	If configured, it gets the permission to clear a specific event from the SW-C. For each event, there can be one port of this interface type.		
IsService	true		
Variation	–		
Possible Errors	0	E_OK	Operation successful
	1	E_NOT_OK	Operation failed

Operation	ClearEventAllowed		
Comment	–		
Mapped to API	<Module>_DemClearEventAllowed<ForCondition>		
Variation	–		
Parameters	Allowed		
	Type	boolean	
	Direction	OUT	
	Comment	True - clearance of event is allowed False - clearance of event is not allowed	
	Variation	–	
Possible Errors	E_OK E_NOT_OK		

E.4.2.2 CallbackEventDataChanged

Name	CallbackEventDataChanged		
Comment	If configured it triggers SW-Cs on event related data changes. For each event, there can be one port of this interface type.		
IsService	true		
Variation	–		
Possible Errors	0	E_OK	Operation successful

Operation	EventDataChanged		
Comment	–		
Mapped to API	–		
Variation	–		
Possible Errors	–		

E.4.2.3 CallbackEventUdsStatusChanged

Name	CallbackEventUdsStatusChanged		
Comment	If configured it triggers SW-Cs on event status byte changes. For each event, there can be several ports of this interface type.		
IsService	true		
Variation	–		
Possible Errors	0	E_OK	Operation successful

Operation	CallbackEventUdsStatusChanged		
Comment	–		
Mapped to API	–		
Variation	–		
Parameters	EventStatusByteOld		
	Type	Dem_UdsStatusByteType	
	Direction	IN	
	Comment	–	
	Variation	–	
	EventStatusByteNew		
	Type	Dem_UdsStatusByteType	
	Direction	IN	
Comment	–		
Variation	–		
Possible Errors	–		

E.4.2.4 CallbackGetFaultDetectCounter

Name	CallbackGetFaultDetectCounter		
Comment	If configured it get the monitor-internal fault detection counter value of a specific event from the SW-C.		
IsService	true		
Variation	–		
Possible Errors	0	E_OK	Operation successful
	1	E_NOT_OK	Operation failed

Operation	GetFaultDetectionCounter		
Comment	–		
Mapped to API	<Module>_DemGetFaultDetectionCounter<ForEvent>		
Variation	–		
Parameters	FaultDetectionCounter		
	Type	sint8	
	Direction	OUT	
	Comment	Value of FaultDetectionCounter	
	Variation	–	
Possible Errors	E_OK E_NOT_OK		

E.4.2.5 CallbackInitMonitorForEvent

Name	CallbackInitMonitorForEvent		
Comment	If configure it triggers an event-specific initialization of the monitor part of the SW-C). For each event, there can be one port of this interface type.		
IsService	true		
Variation	–		
Possible Errors	0	E_OK	Operation successful
	1	E_NOT_OK	Operation failed

Operation	InitMonitorForEvent		
Comment	–		
Mapped to API	<Module>_DemInitMonitorFor<EventName>		
Variation	–		
Parameters	InitMonitorReason		
	Type	Dem_InitMonitorReasonType	
	Direction	IN	
	Comment	–	
	Variation	–	
Possible Errors	E_OK E_NOT_OK		

E.4.2.6 CallbackMonitorStatusChange

Name	CallbackMonitorStatusChange		
Comment	If configured it triggers SW-Cs on monitor status changes. For each event, there can be several ports of this interface type.		
IsService	true		
Variation	–		
Possible Errors	0	E_OK	Operation successful

Operation	MonitorStatusChanged		
Comment	–		
Mapped to API	–		
Variation	–		
Possible Errors	–		

E.4.2.7 DiagnosticInfo

Name	DiagnosticInfo		
Comment	Provides the capability to obtain the event information. One port of this interface type is provided per diagnostic event by the Dem Service Component. It has EventId as a port-defined argument.		
IsService	true		





Variation	–		
Possible Errors	0	E_OK	Operation successful
	1	E_NOT_OK	Operation failed
	10	DEM_E_NO_DTC_AVAILABLE	there is no DTC configured in the requested format
	14	DEM_E_NO_FDC_AVAILABLE	there is no fault detection counter available for the requested event
	21	DEM_BUFFER_TOO_SMALL	The provided buffer size is too small
	48	DEM_NO_SUCH_ELEMENT	The requested event data is not currently stored (but the request was valid) OR The requested record number is not supported by the event OR The requested DID is not supported by the freeze frame (GetEventFreezeFrameDataEx)

Operation	GetDTCOfEvent	
Comment	–	
Mapped to API	Dem_GetDTCOfEvent	
Variation	–	
Parameters	DTCFormat	
	Type	Dem_DTCFormatType
	Direction	IN
	Comment	–
	Variation	–
	DTCOfEvent	
	Type	uint32
	Direction	OUT
	Comment	–
	Variation	–
Possible Errors	E_OK E_NOT_OK DEM_E_NO_DTC_AVAILABLE	

Operation	GetDebouncingOfEvent	
Comment	–	
Mapped to API	Dem_GetDebouncingOfEvent	
Variation	((({ecuc(Dem/DemConfigSet/DemEventParameter/DemDebounceAlgorithmClass)} instanceof {ecuc(Dem/DemConfigSet/DemEventParameter/DemDebounceAlgorithmClass/DemDebounceCounterBased)}) ({ecuc(Dem/DemConfigSet/DemEventParameter/DemDebounceAlgorithmClass)} instanceof {ecuc(Dem/DemConfigSet/DemEventParameter/DemDebounceAlgorithmClass/DemDebounceTimeBased)}))	
Parameters	DebouncingState	
	Type	Dem_DebouncingStateType
	Direction	OUT
	Comment	Bit 0 Temporarily Defective (corresponds to 0 < FDC < 127) Bit 1 finally Defective (corresponds to FDC = 127) Bit 2 temporarily healed (corresponds to -128 < FDC < 0) Bit 3 Test complete (corresponds to FDC = -128 or FDC = 127) Bit 4 DTR Update (= Test complete && Debouncing complete && enable conditions / storage conditions fulfilled)
	Variation	–





Possible Errors	E_OK E_NOT_OK
------------------------	------------------

Operation	GetEventAvailable	
Comment	–	
Mapped to API	Dem_GetEventAvailable	
Variation	–	
Parameters	AvailableStatus	
	Type	boolean*
	Direction	OUT
	Comment	TRUE if the event is available. FALSE if the event is not available.
Variation	–	
Possible Errors	E_OK E_NOT_OK	

Operation	GetEventExtendedDataRecordEx	
Comment	–	
Mapped to API	Dem_GetEventExtendedDataRecordEx	
Variation	–	
Parameters	RecordNumber	
	Type	uint8
	Direction	IN
	Comment	–
	Variation	–
	DestBuffer	
	Type	Dem_MaxDataValueType
	Direction	OUT
	Comment	–
	Variation	–
	Bufsize	
	Type	uint16
Direction	INOUT	
Comment	–	
Variation	–	
Possible Errors	E_OK E_NOT_OK DEM_BUFFER_TOO_SMALL DEM_NO_SUCH_ELEMENT	

Operation	GetEventFreezeFrameDataEx	
Comment	–	
Mapped to API	Dem_GetEventFreezeFrameDataEx	
Variation	–	
Parameters	RecordNumber	
	Type	uint8
	Direction	IN
	Comment	–
	Variation	–
	DataId	





	Type	uint16
	Direction	IN
	Comment	–
	Variation	–
	DestBuffer	
	Type	Dem_MaxDataValueType
	Direction	OUT
	Comment	–
	Variation	–
	BufSize	
	Type	uint16
	Direction	INOUT
	Comment	–
Variation	–	
Possible Errors	E_OK E_NOT_OK DEM_BUFFER_TOO_SMALL DEM_NO_SUCH_ELEMENT	

Operation	GetEventUdsStatus	
Comment	Gets the current UDS status byte assigned to the DTC for the event	
Mapped to API	Dem_GetEventUdsStatus	
Variation	–	
Parameters	UDSStatusByte	
	Type	Dem_UdsStatusByteType
	Direction	OUT
	Comment	–
Variation	–	
Possible Errors	E_OK E_NOT_OK	

Operation	GetFaultDetectionCounter	
Comment	–	
Mapped to API	Dem_GetFaultDetectionCounter	
Variation	–	
Parameters	FaultDetectionCounter	
	Type	sint8
	Direction	OUT
	Comment	–
Variation	–	
Possible Errors	E_OK E_NOT_OK DEM_E_NO_FDC_AVAILABLE	

Operation	GetMonitorStatus
Comment	–
Mapped to API	Dem_GetMonitorStatus
Variation	–
Parameters	MonitorStatus





	Type	Dem_MonitorStatusType
	Direction	OUT
	Comment	Monitor status byte of the requested event. If the return value of the function call is E_NOT_OK, this parameter does not contain valid data.
	Variation	–
Possible Errors	E_OK E_NOT_OK	

E.4.2.8 DiagnosticMonitor

Name	DiagnosticMonitor		
Comment	Provide the capability to modify the event information. One port of this interface type is provided per application-related diagnostic event by the Dem Service Component. It has Event Id as a port-defined argument.		
IsService	true		
Variation	(((Dem/DemGeneral/DemStorageCondition.DemStorageConditionReplacementEvent Ref))!={Dem/DemConfigSet/DemEventParameter}) && ((Dem/DemConfigSet/DemEventParameter/DemEventReportingType) == STANDARD_REPORTING))		
Possible Errors	0	E_OK	Operation successful
	1	E_NOT_OK	Operation failed

Operation	ClearPrestoredFreezeFrame		
Comment	–		
Mapped to API	Dem_ClearPrestoredFreezeFrame		
Variation	{ecuc(Dem/DemGeneral/DemMaxNumberPrestoredFF)} > 0		
Possible Errors	E_OK E_NOT_OK		

Operation	PrestoreFreezeFrame		
Comment	–		
Mapped to API	Dem_PrestoreFreezeFrame		
Variation	{ecuc(Dem/DemGeneral/DemMaxNumberPrestoredFF)} > 0		
Possible Errors	E_OK E_NOT_OK		

Operation	ResetEventDebounceStatus		
Comment	–		
Mapped to API	Dem_ResetEventDebounceStatus		
Variation	((ecuc(Dem/DemGeneral/DemDebounceCounterBasedSupport)) == true) ((ecuc(Dem/DemGeneral/DemDebounceTimeBasedSupport)) == true)		
Parameters	DebounceResetStatus		
	Type	Dem_DebounceResetStatusType	
	Direction	IN	
	Comment	–	
	Variation	–	





Possible Errors	E_OK E_NOT_OK
------------------------	------------------

Operation	ResetEventStatus
Comment	–
Mapped to API	Dem_ResetEventStatus
Variation	–
Possible Errors	E_OK E_NOT_OK

Operation	ResetMonitorStatus
Comment	–
Mapped to API	Dem_ResetMonitorStatus
Variation	–
Possible Errors	E_OK E_NOT_OK

Operation	SetEventDisabled
Comment	–
Mapped to API	Dem_SetEventDisabled
Variation	{ecuc(Dem/DemGeneral.DemOBDSupport)} != DEM_OBD_NO_OBD_SUPPORT
Possible Errors	E_OK E_NOT_OK

Operation	SetEventStatus	
Comment	–	
Mapped to API	Dem_SetEventStatus	
Variation	–	
Parameters	EventStatus	
	Type	Dem_EventStatusType
	Direction	IN
	Comment	–
	Variation	–
Possible Errors	E_OK E_NOT_OK	

E.4.2.9 DiagnosticMonitor_MonitorData

Name	DiagnosticMonitor_MonitorData		
Comment	Provide means to report diagnostic monitor status with monitor data.		
IsService	true		
Variation	({Dem/DemConfigSet/DemEventParameter/DemEventReportingType} == STANDARD_REPORTING_WITH_MONITOR_DATA)		
Possible Errors	0	E_OK	Operation successful
	1	E_NOT_OK	Operation failed

Operation	SetEventStatusWithMonitorData	
Comment	–	
Mapped to API	Dem_SetEventStatusWithMonitorData	
Variation	–	
Parameters	EventStatus	
	Type	Dem_EventStatusType
	Direction	IN
	Comment	–
	Variation	–
	monitorData0	
	Type	Dem_MonitorDataType
	Direction	IN
	Comment	–
	Variation	–
	monitorData1	
	Type	Dem_MonitorDataType
Direction	IN	
Comment	–	
Variation	–	
Possible Errors	E_OK E_NOT_OK	

E.4.2.10 EventStatus

Name	EventStatus		
Comment	Provides the capability modify the event status. One port of this interface type is provided per application-related diagnostic event by the Dem Service Component. It has EventId as a port-defined argument.		
IsService	true		
Variation	–		
Possible Errors	0	E_OK	Operation successful
	1	E_NOT_OK	Operation failed

Operation	SetWIRStatus	
Comment	–	
Mapped to API	Dem_SetWIRStatus	
Variation	–	
Parameters	WIRStatus	
	Type	boolean
	Direction	IN
	Comment	–
	Variation	–
Possible Errors	E_OK E_NOT_OK	

E.4.3 Ports

E.4.3.1 Event

Name	Event_{Name}		
Kind	ProvidedPort	Interface	DiagnosticMonitor
Description	–		
Port Defined Argument Value(s)	Type	Dem_EventIdType	
	Value	{ecuc(Dem/DemConfigSet/DemEventParameter/DemEventId.value)}	
Variation	Name = {ecuc(Dem/DemConfigSet/DemEventParameter.SHORT-NAME)}		

E.4.3.2 DiagnosticMonitor_MonitorData

Name	DiagnosticMonitor_MonitorData_{Name}		
Kind	ProvidedPort	Interface	DiagnosticMonitor_MonitorData
Description	–		
Port Defined Argument Value(s)	Type	Dem_EventIdType	
	Value	{ecuc(Dem/DemConfigSet/DemEventParameter/DemEventId.value)}	
Variation	Name = {ecuc(Dem/DemConfigSet/DemEventParameter.SHORT-NAME)}		

E.4.3.3 EventStatus

Name	EventStatus_{Name}		
Kind	ProvidedPort	Interface	EventStatus
Description	–		
Port Defined Argument Value(s)	Type	Dem_EventIdType	
	Value	{ecuc(Dem/DemConfigSet/DemEventParameter/DemEventId.value)}	
Variation	Name = {ecuc(Dem/DemConfigSet/DemEventParameter.SHORT-NAME)}		

E.4.3.4 EventInfo

Name	EventInfo_{Name}		
Kind	ProvidedPort	Interface	DiagnosticInfo
Description	–		
Port Defined Argument Value(s)	Type	Dem_EventIdType	
	Value	{ecuc(Dem/DemConfigSet/DemEventParameter/DemEventId.value)}	
Variation	Name = {ecuc(Dem/DemConfigSet/DemEventParameter.SHORT-NAME)}		

E.4.3.5 CBClrEvt

Name	CBClrEvt_{Name}		
Kind	RequiredPort	Interface	CallbackClearEventAllowed
Description	–		
Variation	(({ecuc(Dem/DemConfigSet/DemEventParameter/DemCallbackClearEventAllowed)} != NULL) && ({ecuc(Dem/DemConfigSet/DemEventParameter/DemCallbackClearEventAllowed/DemCallback ClearEventAllowedFnc)} == NULL)) Name = {ecuc(Dem/DemConfigSet/DemEventParameter/DemCallbackClearEvent Allowed.SHORT-NAME)}		

E.4.3.6 CBDataEvt

Name	CBDataEvt_{Name}		
Kind	RequiredPort	Interface	CallbackEventDataChanged
Description	–		
Variation	(({ecuc(Dem/DemConfigSet/DemEventParameter/DemCallbackEventDataChanged)} != NULL) && ({ecuc(Dem/DemConfigSet/DemEventParameter/DemCallbackEventDataChanged/DemCallback EventDataChangedFnc)} == NULL)) Name = {ecuc(Dem/DemConfigSet/DemEventParameter.SHORT-NAME)}		

E.4.3.7 CBFaultDetectCtr

Name	CBFaultDetectCtr_{Name}		
Kind	RequiredPort	Interface	CallbackGetFaultDetectCounter
Description	–		
Variation	({ecuc(Dem/DemConfigSet/DemEventParameter/DemDebounceAlgorithmClass/DemDebounce MonitorInternal/DemCallbackGetFDC/DemCallbackGetFDCFnc)} == NULL) Name = {ecuc(Dem/DemConfigSet/DemEventParameter/DemDebounceAlgorithmClass/Dem DebounceMonitorInternal/DemCallbackGetFDC.SHORT-NAME)}		

E.4.3.8 CBInitEvt

Name	CBInitEvt_{Name}		
Kind	RequiredPort	Interface	CallbackInitMonitorForEvent
Description	–		
Variation	(({ecuc(Dem/DemConfigSet/DemEventParameter/DemCallbackInitMForE)} != NULL) && ({ecuc(Dem/DemConfigSet/DemEventParameter/DemCallbackInitMForE/DemCallbackInitMFor EFnc)} == NULL)) Name = {ecuc(Dem/DemConfigSet/DemEventParameter.SHORT-NAME)}		

E.4.3.9 CBEventUdsStatusChanged

Name	CBEventUdsStatusChanged_{EventName}_{CallbackName}		
Kind	RequiredPort	Interface	CallbackEventUdsStatusChanged
Description	–		
Variation	EventName = {ecuc(Dem/DemConfigSet/DemEventParameter.SHORT-NAME)} CallbackName = {ecuc(Dem/DemConfigSet/DemEventParameter/DemCallbackEventUdsStatusChanged.SHORT-NAME)}		

E.4.3.10 CBMonitorStatusChanged

Name	CBMonitorStatusChanged_{EventName}_{CallbackName}		
Kind	RequiredPort	Interface	CallbackMonitorStatusChange
Description	–		
Variation	({ecuc(Dem/DemConfigSet/DemEventParameter.DemEventKind)} == DEM_EVENT_KIND_SWC) EventName = {ecuc(Dem/DemConfigSet/DemEventParameter.SHORT-NAME)} CallbackName = {ecuc(Dem/DemConfigSet/DemEventParameter/DemCallbackMonitorStatusChanged.SHORT-NAME)}		

E.5 FiM

E.5.1 Implementation Data Types

E.5.1.1 FiM_FunctionIdType

Name	FiM_FunctionIdType		
Kind	Type		
Derived from	Basetype	Variation	
	uint16	platform depended	
	uint8	platform depended	
Range	0..255, 0..65535	–	Identifier of functionality Configurable, size depends on System complexity. Remark: Not all numbers are valid. The FiM data generation tool shall only assign valid values.
Description	Type for the FunctionID		
Variation	–		
Available via	Rte_FiM_Type.h		

E.5.2 Client-Server-Interfaces

E.5.2.1 FiM_FunctionInhibition

Name	FunctionInhibition		
Comment	The SW Components can use this service to query for the permission to execute a certain functionality represented by a FID.		
IsService	true		
Variation	–		
Possible Errors	0	E_OK	Operation successful
	1	E_NOT_OK	Operation failed

Operation	GetFunctionPermission		
Comment	Get the permission state of the respective FID.		
Mapped to API	FiM_GetFunctionPermission		
Variation	–		
Parameters	Permission		
	Type	boolean	
	Direction	OUT	
	Comment	The permission of the requested FID. TRUE: FID has permission to run FALSE: FID has no permission to run, i.e. shall not be executed	
Variation	–		
Possible Errors	E_OK E_NOT_OK		

E.5.2.2 FiM_ControlFunctionAvailable

Name	ControlFunctionAvailable		
Comment	SW Components can use this service to set the availability of a function.		
IsService	true		
Variation	({ecuc(FiM/FiMGeneral/FiMAvailabilitySupport)} == True)		
Possible Errors	0	E_OK	Operation successful
	1	E_NOT_OK	Operation failed

Operation	SetFunctionAvailable		
Comment	Sets the availability of a function.		
Mapped to API	FiM_SetFunctionAvailable		
Variation	–		
Parameters	Availability		
	Type	boolean	
	Direction	IN	
	Comment	The permission of the requested FID: TRUE: Function is available. FALSE: Function is not available.	
Variation	–		





Possible Errors	E_OK E_NOT_OK
------------------------	------------------

E.5.3 Ports

E.5.3.1 FiM_FunctionInhibition

Name	Func_{Name}		
Kind	ProvidedPort	Interface	FunctionInhibition
Description	A client can query the FiM for execution permission for a specific function. The FIDs which represent the functions are not directly used by the client SW-C. Instead, the mechanism of "port-defined argument values" is used and every FID is mapped to a separate port that is responsible for the data exchange via RTE.		
Port Defined Argument Value(s)	Type	FiM_FunctionIdType	
	Value	{ecuc(FiM/FiMConfigSet/FiMFID/FiMFunctionId.value)}	
Variation	Name = {ecuc(FiM/FiMConfigSet/FiMFID.SHORT-NAME)}		

E.5.3.2 FiM_ControlFunctionAvailable

Name	Control_{Name}		
Kind	ProvidedPort	Interface	ControlFunctionAvailable
Description	A client can set the availability for a specific function.		
Port Defined Argument Value(s)	Type	FiM_FunctionIdType	
	Value	{ecuc(FiM/FiMConfigSet/FiMFID/FiMFunctionId.value)}	
Variation	({ecuc(FiM/FiMGeneral/FiMAvailabilitySupport)} == True) Name = {ecuc(FiM/FiMConfigSet/FiMFID.SHORT-NAME)}		

F Changes History

F.1 Changes in R20-11 compared to R19-11

Please note that the document was initially created in R20-11.

F.1.1 Added Traceables in R20-11

[SWS_SwCluC_00001] [SWS_SwCluC_00002] [SWS_SwCluC_00003] [SWS_SwCluC_00004] [SWS_SwCluC_00005] [SWS_SwCluC_00006] [SWS_SwCluC_00007] [SWS_SwCluC_00008] [SWS_SwCluC_00009] [SWS_SwCluC_00010] [SWS_SwCluC_00011] [SWS_SwCluC_00012] [SWS_SwCluC_00013] [SWS_SwCluC_00014] [SWS_SwCluC_00015] [SWS_SwCluC_00016] [SWS_SwCluC_00017] [SWS_SwCluC_00018] [SWS_SwCluC_00019] [SWS_SwCluC_00020] [SWS_SwCluC_00021] [SWS_SwCluC_00022] [SWS_SwCluC_00023] [SWS_SwCluC_00024] [SWS_SwCluC_00025] [SWS_SwCluC_00026] [SWS_SwCluC_00027] [SWS_SwCluC_00028] [SWS_SwCluC_00029] [SWS_SwCluC_00030] [SWS_SwCluC_00031] [SWS_SwCluC_00032] [SWS_SwCluC_00033] [SWS_SwCluC_00034] [SWS_SwCluC_00035] [SWS_SwCluC_00036] [SWS_SwCluC_00037] [SWS_SwCluC_00038] [SWS_SwCluC_00039] [SWS_SwCluC_00040] [SWS_SwCluC_00041] [SWS_SwCluC_00042] [SWS_SwCluC_00043] [SWS_SwCluC_00044] [SWS_SwCluC_00045] [SWS_SwCluC_00046] [SWS_SwCluC_00047] [SWS_SwCluC_00048] [SWS_SwCluC_00049] [SWS_SwCluC_00050] [SWS_SwCluC_00051] [SWS_SwCluC_00052] [SWS_SwCluC_00053] [SWS_SwCluC_00054] [SWS_SwCluC_00055] [SWS_SwCluC_00056] [SWS_SwCluC_00057] [SWS_SwCluC_00058] [SWS_SwCluC_00059] [SWS_SwCluC_00060] [SWS_SwCluC_00061] [SWS_SwCluC_00062] [SWS_SwCluC_00063] [SWS_SwCluC_00064] [SWS_SwCluC_00065] [SWS_SwCluC_00066] [SWS_SwCluC_00067] [SWS_SwCluC_00068] [SWS_SwCluC_00069] [SWS_SwCluC_00070] [SWS_SwCluC_00071] [SWS_SwCluC_00072] [SWS_SwCluC_00075] [SWS_SwCluC_00076] [SWS_SwCluC_00077] [SWS_SwCluC_00079] [SWS_SwCluC_00080] [SWS_SwCluC_00081] [SWS_SwCluC_00082] [SWS_SwCluC_00083] [SWS_SwCluC_00084] [SWS_SwCluC_00085] [SWS_SwCluC_00086] [SWS_SwCluC_00088] [SWS_SwCluC_00089] [SWS_SwCluC_00999] [SWS_SwCluC_01000] [SWS_SwCluC_01002] [SWS_SwCluC_02000] [SWS_SwCluC_02001] [SWS_SwCluC_02002] [SWS_SwCluC_02003] [SWS_SwCluC_02004] [SWS_SwCluC_02005] [SWS_SwCluC_02006] [SWS_SwCluC_02007] [SWS_SwCluC_02008] [SWS_SwCluC_02101] [SWS_SwCluC_02102] [SWS_SwCluC_02103] [SWS_SwCluC_02104] [SWS_SwCluC_02105] [SWS_SwCluC_02106] [SWS_SwCluC_02107] [SWS_SwCluC_02108] [SWS_SwCluC_02109] [SWS_SwCluC_02110] [SWS_SwCluC_02111] [SWS_SwCluC_02112] [SWS_SwCluC_02113] [SWS_SwCluC_02114] [SWS_SwCluC_02115] [SWS_SwCluC_02116] [SWS_SwCluC_02117] [SWS_SwCluC_02118] [SWS_SwCluC_02119] [SWS_SwCluC_02120] [SWS_SwCluC_02121] [SWS_SwCluC_02122] [SWS_SwCluC_02123]

[SWS_SwCluC_02124] [SWS_SwCluC_02125] [SWS_SwCluC_02126] [SWS_SwCluC_02127] [SWS_SwCluC_02128] [SWS_SwCluC_02129] [SWS_SwCluC_02132] [SWS_SwCluC_02133] [SWS_SwCluC_02136] [SWS_SwCluC_02137] [SWS_SwCluC_02138] [SWS_SwCluC_02139] [SWS_SwCluC_02140] [SWS_SwCluC_02142] [SWS_SwCluC_02143] [SWS_SwCluC_02144] [SWS_SwCluC_02200] [SWS_SwCluC_02201] [SWS_SwCluC_02202] [SWS_SwCluC_02204] [SWS_SwCluC_02205] [SWS_SwCluC_02206] [SWS_SwCluC_02210] [SWS_SwCluC_02211] [SWS_SwCluC_02212] [SWS_SwCluC_02213] [SWS_SwCluC_02214] [SWS_SwCluC_02215] [SWS_SwCluC_02216] [SWS_SwCluC_02217] [SWS_SwCluC_02218] [SWS_SwCluC_02219] [SWS_SwCluC_02220] [SWS_SwCluC_02221] [SWS_SwCluC_02222] [SWS_SwCluC_02223] [SWS_SwCluC_02224] [SWS_SwCluC_02225] [SWS_SwCluC_02226] [SWS_SwCluC_02227] [SWS_SwCluC_02229] [SWS_SwCluC_02230] [SWS_SwCluC_02250] [SWS_SwCluC_02251] [SWS_SwCluC_02252] [SWS_SwCluC_02253] [SWS_SwCluC_02254] [SWS_SwCluC_02255] [SWS_SwCluC_02256] [SWS_SwCluC_02257] [SWS_SwCluC_02258] [SWS_SwCluC_02259] [SWS_SwCluC_02260] [SWS_SwCluC_02261] [SWS_SwCluC_02262] [SWS_SwCluC_02263] [SWS_SwCluC_02264] [SWS_SwCluC_02265] [SWS_SwCluC_02266] [SWS_SwCluC_03000] [SWS_SwCluC_03001] [SWS_SwCluC_03002] [SWS_SwCluC_03003] [SWS_SwCluC_03004] [SWS_SwCluC_03005] [SWS_SwCluC_03006] [SWS_SwCluC_03007] [SWS_SwCluC_03008] [SWS_SwCluC_03009] [SWS_SwCluC_03010] [SWS_SwCluC_03011] [SWS_SwCluC_03012] [SWS_SwCluC_03013] [SWS_SwCluC_03015] [SWS_SwCluC_03016] [SWS_SwCluC_03017] [SWS_SwCluC_03018] [SWS_SwCluC_03019] [SWS_SwCluC_03022] [SWS_SwCluC_03023] [SWS_SwCluC_03024] [SWS_SwCluC_03025] [SWS_SwCluC_03026] [SWS_SwCluC_03027] [SWS_SwCluC_03028] [SWS_SwCluC_03029] [SWS_SwCluC_03030] [SWS_SwCluC_03031] [SWS_SwCluC_03033] [SWS_SwCluC_03034] [SWS_SwCluC_03035] [SWS_SwCluC_03036] [SWS_SwCluC_03037] [SWS_SwCluC_03038] [SWS_SwCluC_03039] [SWS_SwCluC_03040] [SWS_SwCluC_03041] [SWS_SwCluC_03042] [SWS_SwCluC_03043] [SWS_SwCluC_03044] [SWS_SwCluC_03045] [SWS_SwCluC_03046] [SWS_SwCluC_03047] [SWS_SwCluC_03048] [SWS_SwCluC_03049] [SWS_SwCluC_03050] [SWS_SwCluC_03051] [SWS_SwCluC_03052] [SWS_SwCluC_03055] [SWS_SwCluC_03056] [SWS_SwCluC_03057] [SWS_SwCluC_03058] [SWS_SwCluC_03060] [SWS_SwCluC_03061] [SWS_SwCluC_03062] [SWS_SwCluC_03063] [SWS_SwCluC_03064] [SWS_SwCluC_03065] [SWS_SwCluC_03068] [SWS_SwCluC_03071] [SWS_SwCluC_03072] [SWS_SwCluC_03073] [SWS_SwCluC_03074] [SWS_SwCluC_03075] [SWS_SwCluC_03076] [SWS_SwCluC_03077] [SWS_SwCluC_03101] [SWS_SwCluC_03102] [SWS_SwCluC_03103] [SWS_SwCluC_03106] [SWS_SwCluC_03107] [SWS_SwCluC_03108] [SWS_SwCluC_03109] [SWS_SwCluC_03110] [SWS_SwCluC_03111] [SWS_SwCluC_03112] [SWS_SwCluC_03113] [SWS_SwCluC_03120] [SWS_SwCluC_03121] [SWS_SwCluC_03122] [SWS_SwCluC_03123] [SWS_SwCluC_03124] [SWS_SwCluC_03126] [SWS_SwCluC_03130] [SWS_SwCluC_03131] [SWS_SwCluC_03132] [SWS_SwCluC_03133] [SWS_SwCluC_03134] [SWS_SwCluC_03135] [SWS_SwCluC_03136]

[SWS_SwCluC_03137] [SWS_SwCluC_03138] [SWS_SwCluC_03139] [SWS_SwCluC_03140] [SWS_SwCluC_03142] [SWS_SwCluC_03143] [SWS_SwCluC_03144] [SWS_SwCluC_03145] [SWS_SwCluC_03146] [SWS_SwCluC_03147] [SWS_SwCluC_03150] [SWS_SwCluC_03151] [SWS_SwCluC_03152] [SWS_SwCluC_03153] [SWS_SwCluC_03154] [SWS_SwCluC_03155] [SWS_SwCluC_03156] [SWS_SwCluC_03157] [SWS_SwCluC_03158] [SWS_SwCluC_03159] [SWS_SwCluC_03160] [SWS_SwCluC_03161] [SWS_SwCluC_03162] [SWS_SwCluC_03163] [SWS_SwCluC_03164] [SWS_SwCluC_03165] [SWS_SwCluC_03166] [SWS_SwCluC_03167] [SWS_SwCluC_03168] [SWS_SwCluC_03169] [SWS_SwCluC_03170] [SWS_SwCluC_03171] [SWS_SwCluC_03173] [SWS_SwCluC_03174] [SWS_SwCluC_03175] [SWS_SwCluC_03176] [SWS_SwCluC_03177] [SWS_SwCluC_10000] [SWS_SwCluC_10001] [SWS_SwCluC_10002] [SWS_SwCluC_10003] [SWS_SwCluC_10004] [SWS_SwCluC_10005] [SWS_SwCluC_10006] [SWS_SwCluC_10007] [SWS_SwCluC_10008] [SWS_SwCluC_10009] [SWS_SwCluC_10010] [SWS_SwCluC_10011] [SWS_SwCluC_10020] [SWS_SwCluC_10021] [SWS_SwCluC_10022] [SWS_SwCluC_10023] [SWS_SwCluC_10032] [SWS_SwCluC_10033] [SWS_SwCluC_10034] [SWS_SwCluC_11000] [SWS_SwCluC_11001] [SWS_SwCluC_12000] [SWS_SwCluC_12100] [SWS_SwCluC_90000] [SWS_SwCluC_90001] [SWS_SwCluC_90002] [SWS_SwCluC_90003] [SWS_SwCluC_90004] [SWS_SwCluC_90005] [SWS_SwCluC_90006] [SWS_SwCluC_90007] [SWS_SwCluC_90008] [SWS_SwCluC_90009] [SWS_SwCluC_90010] [SWS_SwCluC_CONSTR_00073] [SWS_SwCluC_CONSTR_00074] [SWS_SwCluC_CONSTR_00078] [SWS_SwCluC_CONSTR_00087] [SWS_SwCluC_CONSTR_02130] [SWS_SwCluC_CONSTR_02131] [SWS_SwCluC_CONSTR_02134] [SWS_SwCluC_CONSTR_02135] [SWS_SwCluC_CONSTR_02141] [SWS_SwCluC_CONSTR_02203] [SWS_SwCluC_CONSTR_02228] [SWS_SwCluC_CONSTR_02282] [SWS_SwCluC_CONSTR_02283] [SWS_SwCluC_CONSTR_02231] [SWS_SwCluC_CONSTR_02232] [SWS_SwCluC_CONSTR_02233] [SWS_SwCluC_CONSTR_02234] [SWS_SwCluC_CONSTR_02235] [SWS_SwCluC_CONSTR_02236] [SWS_SwCluC_CONSTR_02237] [SWS_SwCluC_CONSTR_03020] [SWS_SwCluC_CONSTR_03021] [SWS_SwCluC_CONSTR_03032] [SWS_SwCluC_CONSTR_03053] [SWS_SwCluC_CONSTR_03054] [SWS_SwCluC_CONSTR_03059] [SWS_SwCluC_CONSTR_03063] [SWS_SwCluC_CONSTR_03066] [SWS_SwCluC_CONSTR_03067] [SWS_SwCluC_CONSTR_03069]

F.1.2 Changed Traceables in R20-11

none

F.1.3 Deleted Traceables in R20-11

none

F.2 Changes in R21-11 compared to R20-11

F.2.1 Added Traceables in R21-11

[SWS_SwCluC_00090] [SWS_SwCluC_02270] [SWS_SwCluC_02271] [SWS_SwCluC_02272] [SWS_SwCluC_02273] [SWS_SwCluC_02274] [SWS_SwCluC_02275] [SWS_SwCluC_02276] [SWS_SwCluC_02277] [SWS_SwCluC_02300] [SWS_SwCluC_02301] [SWS_SwCluC_02302] [SWS_SwCluC_02303] [SWS_SwCluC_02304] [SWS_SwCluC_02305] [SWS_SwCluC_02306] [SWS_SwCluC_02307] [SWS_SwCluC_02308] [SWS_SwCluC_02309] [SWS_SwCluC_02310] [SWS_SwCluC_02311] [SWS_SwCluC_02312] [SWS_SwCluC_02313] [SWS_SwCluC_02314] [SWS_SwCluC_02315] [SWS_SwCluC_02316] [SWS_SwCluC_02317] [SWS_SwCluC_02318] [SWS_SwCluC_02319] [SWS_SwCluC_02320] [SWS_SwCluC_02321] [SWS_SwCluC_02322] [SWS_SwCluC_02323] [SWS_SwCluC_02324] [SWS_SwCluC_02325] [SWS_SwCluC_02330] [SWS_SwCluC_02331] [SWS_SwCluC_02332] [SWS_SwCluC_02333] [SWS_SwCluC_02334] [SWS_SwCluC_02335] [SWS_SwCluC_02336] [SWS_SwCluC_02337] [SWS_SwCluC_02338] [SWS_SwCluC_02339] [SWS_SwCluC_02341] [SWS_SwCluC_02342] [SWS_SwCluC_02350] [SWS_SwCluC_02351] [SWS_SwCluC_02352] [SWS_SwCluC_02353] [SWS_SwCluC_02354] [SWS_SwCluC_02355] [SWS_SwCluC_02356] [SWS_SwCluC_02357] [SWS_SwCluC_02358] [SWS_SwCluC_02359] [SWS_SwCluC_02360] [SWS_SwCluC_02361] [SWS_SwCluC_02362] [SWS_SwCluC_02363] [SWS_SwCluC_02364] [SWS_SwCluC_02365] [SWS_SwCluC_02366] [SWS_SwCluC_02367] [SWS_SwCluC_02368] [SWS_SwCluC_02369] [SWS_SwCluC_02370] [SWS_SwCluC_02371] [SWS_SwCluC_02372] [SWS_SwCluC_02373] [SWS_SwCluC_02374] [SWS_SwCluC_02375] [SWS_SwCluC_02376] [SWS_SwCluC_02380] [SWS_SwCluC_02381] [SWS_SwCluC_02382] [SWS_SwCluC_02383] [SWS_SwCluC_02384] [SWS_SwCluC_02385] [SWS_SwCluC_02386] [SWS_SwCluC_02387] [SWS_SwCluC_02388] [SWS_SwCluC_02390] [SWS_SwCluC_02391] [SWS_SwCluC_02392] [SWS_SwCluC_02393] [SWS_SwCluC_02394] [SWS_SwCluC_02395] [SWS_SwCluC_02396] [SWS_SwCluC_02397] [SWS_SwCluC_02400] [SWS_SwCluC_02401] [SWS_SwCluC_02402] [SWS_SwCluC_02403] [SWS_SwCluC_02404] [SWS_SwCluC_02405] [SWS_SwCluC_02406] [SWS_SwCluC_02407] [SWS_SwCluC_02408] [SWS_SwCluC_02409] [SWS_SwCluC_02410] [SWS_SwCluC_02411] [SWS_SwCluC_02412] [SWS_SwCluC_02413] [SWS_SwCluC_02414] [SWS_SwCluC_02415] [SWS_SwCluC_02416] [SWS_SwCluC_02417] [SWS_SwCluC_02418] [SWS_SwCluC_02419] [SWS_SwCluC_02420] [SWS_SwCluC_02421] [SWS_SwCluC_02422] [SWS_SwCluC_02423] [SWS_SwCluC_02424] [SWS_SwCluC_02425] [SWS_SwCluC_02426] [SWS_SwCluC_02500] [SWS_SwCluC_02501] [SWS_SwCluC_02502] [SWS_SwCluC_02503] [SWS_SwCluC_02504] [SWS_SwCluC_02505] [SWS_SwCluC_02506] [SWS_SwCluC_02507] [SWS_SwCluC_02508] [SWS_SwCluC_02509] [SWS_SwCluC_02510] [SWS_SwCluC_02511] [SWS_SwCluC_02512] [SWS_SwCluC_02513] [SWS_SwCluC_02514] [SWS_SwCluC_02515] [SWS_SwCluC_02516] [SWS_SwCluC_02517] [SWS_SwCluC_02518] [SWS_SwCluC_02519] [SWS_SwCluC_02520] [SWS_SwCluC_02521]

[SWS_SwCluC_02522] [SWS_SwCluC_02523] [SWS_SwCluC_02524] [SWS_SwCluC_02525] [SWS_SwCluC_02526] [SWS_SwCluC_02527] [SWS_SwCluC_02528] [SWS_SwCluC_02529] [SWS_SwCluC_02530] [SWS_SwCluC_02531] [SWS_SwCluC_02532] [SWS_SwCluC_02533] [SWS_SwCluC_02534] [SWS_SwCluC_02535] [SWS_SwCluC_02536] [SWS_SwCluC_02537] [SWS_SwCluC_02538] [SWS_SwCluC_02539] [SWS_SwCluC_02540] [SWS_SwCluC_02541] [SWS_SwCluC_02542] [SWS_SwCluC_02543] [SWS_SwCluC_02544] [SWS_SwCluC_02545] [SWS_SwCluC_02548] [SWS_SwCluC_02549] [SWS_SwCluC_02550] [SWS_SwCluC_02551] [SWS_SwCluC_02552] [SWS_SwCluC_02600] [SWS_SwCluC_02601] [SWS_SwCluC_02602] [SWS_SwCluC_02603] [SWS_SwCluC_02604] [SWS_SwCluC_02605] [SWS_SwCluC_02606] [SWS_SwCluC_02607] [SWS_SwCluC_02608] [SWS_SwCluC_02609] [SWS_SwCluC_02610] [SWS_SwCluC_02611] [SWS_SwCluC_02612] [SWS_SwCluC_02613] [SWS_SwCluC_02614] [SWS_SwCluC_02615] [SWS_SwCluC_02616] [SWS_SwCluC_02617] [SWS_SwCluC_02618] [SWS_SwCluC_02619] [SWS_SwCluC_02620] [SWS_SwCluC_02621] [SWS_SwCluC_02622] [SWS_SwCluC_02623] [SWS_SwCluC_02624] [SWS_SwCluC_02625] [SWS_SwCluC_02626] [SWS_SwCluC_02627] [SWS_SwCluC_02628] [SWS_SwCluC_02629] [SWS_SwCluC_02630] [SWS_SwCluC_02631] [SWS_SwCluC_02632] [SWS_SwCluC_02633] [SWS_SwCluC_02634] [SWS_SwCluC_02636] [SWS_SwCluC_02637] [SWS_SwCluC_02638] [SWS_SwCluC_02639] [SWS_SwCluC_02640] [SWS_SwCluC_02642] [SWS_SwCluC_02643] [SWS_SwCluC_02644] [SWS_SwCluC_02645] [SWS_SwCluC_02646] [SWS_SwCluC_02647] [SWS_SwCluC_02648] [SWS_SwCluC_02649] [SWS_SwCluC_02650] [SWS_SwCluC_02651] [SWS_SwCluC_02652] [SWS_SwCluC_02661] [SWS_SwCluC_02662] [SWS_SwCluC_02663] [SWS_SwCluC_02700] [SWS_SwCluC_02701] [SWS_SwCluC_02702] [SWS_SwCluC_02703] [SWS_SwCluC_02704] [SWS_SwCluC_02705] [SWS_SwCluC_02706] [SWS_SwCluC_02707] [SWS_SwCluC_02708] [SWS_SwCluC_02709] [SWS_SwCluC_02710] [SWS_SwCluC_02711] [SWS_SwCluC_02712] [SWS_SwCluC_02713] [SWS_SwCluC_02714] [SWS_SwCluC_02715] [SWS_SwCluC_02716] [SWS_SwCluC_02717] [SWS_SwCluC_02718] [SWS_SwCluC_02719] [SWS_SwCluC_02723] [SWS_SwCluC_02724] [SWS_SwCluC_02725] [SWS_SwCluC_02726] [SWS_SwCluC_02727] [SWS_SwCluC_02728] [SWS_SwCluC_02729] [SWS_SwCluC_02730] [SWS_SwCluC_02731] [SWS_SwCluC_02732] [SWS_SwCluC_02733] [SWS_SwCluC_02734] [SWS_SwCluC_02735] [SWS_SwCluC_02736] [SWS_SwCluC_02737] [SWS_SwCluC_02738] [SWS_SwCluC_02739] [SWS_SwCluC_02740] [SWS_SwCluC_02741] [SWS_SwCluC_02742] [SWS_SwCluC_02743] [SWS_SwCluC_02744] [SWS_SwCluC_02745] [SWS_SwCluC_02746] [SWS_SwCluC_02747] [SWS_SwCluC_02748] [SWS_SwCluC_02749] [SWS_SwCluC_02750] [SWS_SwCluC_02751] [SWS_SwCluC_03080] [SWS_SwCluC_03081] [SWS_SwCluC_03082] [SWS_SwCluC_03200] [SWS_SwCluC_03201] [SWS_SwCluC_03202] [SWS_SwCluC_03203] [SWS_SwCluC_03204] [SWS_SwCluC_03205] [SWS_SwCluC_03206] [SWS_SwCluC_03207] [SWS_SwCluC_03208] [SWS_SwCluC_03209] [SWS_SwCluC_03210] [SWS_SwCluC_03211] [SWS_SwCluC_03212] [SWS_SwCluC_03213] [SWS_SwCluC_03214]

[SWS_SwCluC_03215] [SWS_SwCluC_03216] [SWS_SwCluC_03217] [SWS_SwCluC_03218] [SWS_SwCluC_12200] [SWS_SwCluC_12300] [SWS_SwCluC_12400] [SWS_SwCluC_13000] [SWS_SwCluC_13001] [SWS_SwCluC_13002] [SWS_SwCluC_13003] [SWS_SwCluC_13004] [SWS_SwCluC_13005] [SWS_SwCluC_13006] [SWS_SwCluC_13007] [SWS_SwCluC_13008] [SWS_SwCluC_13009] [SWS_SwCluC_13010] [SWS_SwCluC_13011] [SWS_SwCluC_13012] [SWS_SwCluC_13013] [SWS_SwCluC_13014] [SWS_SwCluC_13015] [SWS_SwCluC_90011] [SWS_SwCluC_90012] [SWS_SwCluC_90013] [SWS_SwCluC_90014] [SWS_SwCluC_90015] [SWS_SwCluC_90016] [SWS_SwCluC_90017] [SWS_SwCluC_90018] [SWS_SwCluC_90019] [SWS_SwCluC_90020] [SWS_SwCluC_90021] [SWS_SwCluC_90022] [SWS_SwCluC_CONSTR_00091] [SWS_SwCluC_CONSTR_00092] [SWS_SwCluC_CONSTR_00093] [SWS_SwCluC_CONSTR_00094] [SWS_SwCluC_CONSTR_02427] [SWS_SwCluC_CONSTR_02428] [SWS_SwCluC_CONSTR_02429] [SWS_SwCluC_CONSTR_02546] [SWS_SwCluC_CONSTR_02547] [SWS_SwCluC_CONSTR_02553] [SWS_SwCluC_CONSTR_02554] [SWS_SwCluC_CONSTR_02555] [SWS_SwCluC_CONSTR_02556] [SWS_SwCluC_CONSTR_02557] [SWS_SwCluC_CONSTR_02558] [SWS_SwCluC_CONSTR_02559] [SWS_SwCluC_CONSTR_02560] [SWS_SwCluC_CONSTR_02561] [SWS_SwCluC_CONSTR_02562] [SWS_SwCluC_CONSTR_02653] [SWS_SwCluC_CONSTR_02654] [SWS_SwCluC_CONSTR_02655] [SWS_SwCluC_CONSTR_02656] [SWS_SwCluC_CONSTR_02657] [SWS_SwCluC_CONSTR_02658] [SWS_SwCluC_CONSTR_02659] [SWS_SwCluC_CONSTR_02660] [SWS_SwCluC_CONSTR_02664] [SWS_SwCluC_CONSTR_02720] [SWS_SwCluC_CONSTR_02721] [SWS_SwCluC_CONSTR_02752] [SWS_SwCluC_CONSTR_03210] [SWS_SwCluC_CONSTR_03211]

F.2.2 Changed Traceables in R21-11

[SWS_SwCluC_00005] [SWS_SwCluC_00018] [SWS_SwCluC_00019] [SWS_SwCluC_00031] [SWS_SwCluC_00040] [SWS_SwCluC_00086] [SWS_SwCluC_00999] [SWS_SwCluC_02259] [SWS_SwCluC_02262] [SWS_SwCluC_02263] [SWS_SwCluC_02264] [SWS_SwCluC_03035] [SWS_SwCluC_10011]

F.2.3 Deleted Traceables in R21-11

[SWS_SwCluC_00038] [SWS_SwCluC_00039] [SWS_SwCluC_00071] [SWS_SwCluC_00084] [SWS_SwCluC_02257] [SWS_SwCluC_02258] [SWS_SwCluC_02260] [SWS_SwCluC_02261] [SWS_SwCluC_CONSTR_00074]

F.3 Changes in R22-11 compared to R21-11

F.3.1 Added Traceables in R22-11

[SWS_SwCluC_00095] [SWS_SwCluC_02278] [SWS_SwCluC_02279] [SWS_SwCluC_02280] [SWS_SwCluC_03083] [SWS_SwCluC_03084] [SWS_SwCluC_03085] [SWS_SwCluC_03086] [SWS_SwCluC_03087] [SWS_SwCluC_03088] [SWS_SwCluC_03089] [SWS_SwCluC_03090] [SWS_SwCluC_03091] [SWS_SwCluC_03092] [SWS_SwCluC_03094] [SWS_SwCluC_03095] [SWS_SwCluC_03096] [SWS_SwCluC_03097] [SWS_SwCluC_03098] [SWS_SwCluC_03099] [SWS_SwCluC_03178] [SWS_SwCluC_03401] [SWS_SwCluC_03402] [SWS_SwCluC_09000] [SWS_SwCluC_09001] [SWS_SwCluC_10012] [SWS_SwCluC_91001] [SWS_SwCluC_91002] [SWS_SwCluC_CONSTR_00096] [SWS_SwCluC_CONSTR_02281] [SWS_SwCluC_CONSTR_02282] [SWS_SwCluC_CONSTR_02283] [SWS_SwCluC_CONSTR_03093] [SWS_SwCluC_CONSTR_03400] [SWS_SwCluC_CONSTR_03403] [SWS_SwCluC_NA_00999]

F.3.2 Changed Traceables in R22-11

[SWS_SwCluC_00008] [SWS_SwCluC_00009] [SWS_SwCluC_00015] [SWS_SwCluC_00022] [SWS_SwCluC_00027] [SWS_SwCluC_00041] [SWS_SwCluC_00042] [SWS_SwCluC_00043] [SWS_SwCluC_00076] [SWS_SwCluC_00077] [SWS_SwCluC_00085] [SWS_SwCluC_02000] [SWS_SwCluC_02007] [SWS_SwCluC_02101] [SWS_SwCluC_02103] [SWS_SwCluC_02104] [SWS_SwCluC_02105] [SWS_SwCluC_02106] [SWS_SwCluC_02121] [SWS_SwCluC_02125] [SWS_SwCluC_02137] [SWS_SwCluC_02138] [SWS_SwCluC_02139] [SWS_SwCluC_02143] [SWS_SwCluC_02144] [SWS_SwCluC_02200] [SWS_SwCluC_02201] [SWS_SwCluC_02202] [SWS_SwCluC_02204] [SWS_SwCluC_02205] [SWS_SwCluC_02211] [SWS_SwCluC_02212] [SWS_SwCluC_02213] [SWS_SwCluC_02214] [SWS_SwCluC_02215] [SWS_SwCluC_02216] [SWS_SwCluC_02217] [SWS_SwCluC_02220] [SWS_SwCluC_02221] [SWS_SwCluC_02222] [SWS_SwCluC_02223] [SWS_SwCluC_02224] [SWS_SwCluC_02225] [SWS_SwCluC_02226] [SWS_SwCluC_02227] [SWS_SwCluC_02229] [SWS_SwCluC_02252] [SWS_SwCluC_02253] [SWS_SwCluC_02254] [SWS_SwCluC_02255] [SWS_SwCluC_02256] [SWS_SwCluC_02259] [SWS_SwCluC_02262] [SWS_SwCluC_02263] [SWS_SwCluC_02264] [SWS_SwCluC_02265] [SWS_SwCluC_02266] [SWS_SwCluC_02270] [SWS_SwCluC_02271] [SWS_SwCluC_02301] [SWS_SwCluC_02302] [SWS_SwCluC_02303] [SWS_SwCluC_02308] [SWS_SwCluC_02309] [SWS_SwCluC_02310] [SWS_SwCluC_02311] [SWS_SwCluC_02315] [SWS_SwCluC_02316] [SWS_SwCluC_02317] [SWS_SwCluC_02318] [SWS_SwCluC_02322] [SWS_SwCluC_02323] [SWS_SwCluC_02324] [SWS_SwCluC_02330] [SWS_SwCluC_02331] [SWS_SwCluC_02333] [SWS_SwCluC_02334] [SWS_SwCluC_02338] [SWS_SwCluC_02339] [SWS_SwCluC_02425]

[SWS_SwCluC_02500] [SWS_SwCluC_02501] [SWS_SwCluC_02502] [SWS_SwCluC_02503] [SWS_SwCluC_02504] [SWS_SwCluC_02506] [SWS_SwCluC_02507] [SWS_SwCluC_02510] [SWS_SwCluC_02511] [SWS_SwCluC_02512] [SWS_SwCluC_02513] [SWS_SwCluC_02514] [SWS_SwCluC_02515] [SWS_SwCluC_02516] [SWS_SwCluC_02517] [SWS_SwCluC_02520] [SWS_SwCluC_02533] [SWS_SwCluC_02534] [SWS_SwCluC_02543] [SWS_SwCluC_02548] [SWS_SwCluC_02600] [SWS_SwCluC_02601] [SWS_SwCluC_02602] [SWS_SwCluC_02603] [SWS_SwCluC_02604] [SWS_SwCluC_02605] [SWS_SwCluC_02607] [SWS_SwCluC_02608] [SWS_SwCluC_02609] [SWS_SwCluC_02610] [SWS_SwCluC_02611] [SWS_SwCluC_02612] [SWS_SwCluC_02618] [SWS_SwCluC_02619] [SWS_SwCluC_02620] [SWS_SwCluC_02621] [SWS_SwCluC_02622] [SWS_SwCluC_02623] [SWS_SwCluC_02626] [SWS_SwCluC_02628] [SWS_SwCluC_02629] [SWS_SwCluC_02630] [SWS_SwCluC_02631] [SWS_SwCluC_02632] [SWS_SwCluC_02634] [SWS_SwCluC_02636] [SWS_SwCluC_02637] [SWS_SwCluC_02638] [SWS_SwCluC_02644] [SWS_SwCluC_02645] [SWS_SwCluC_02648] [SWS_SwCluC_02649] [SWS_SwCluC_02652] [SWS_SwCluC_02661] [SWS_SwCluC_02701] [SWS_SwCluC_02702] [SWS_SwCluC_02703] [SWS_SwCluC_02704] [SWS_SwCluC_02705] [SWS_SwCluC_02706] [SWS_SwCluC_02707] [SWS_SwCluC_02723] [SWS_SwCluC_02724] [SWS_SwCluC_02725] [SWS_SwCluC_02726] [SWS_SwCluC_02727] [SWS_SwCluC_02728] [SWS_SwCluC_02736] [SWS_SwCluC_02737] [SWS_SwCluC_02738] [SWS_SwCluC_02739] [SWS_SwCluC_02740] [SWS_SwCluC_02741] [SWS_SwCluC_02742] [SWS_SwCluC_02743] [SWS_SwCluC_02744] [SWS_SwCluC_02746] [SWS_SwCluC_02748] [SWS_SwCluC_02749] [SWS_SwCluC_02751] [SWS_SwCluC_03005] [SWS_SwCluC_03023] [SWS_SwCluC_03024] [SWS_SwCluC_03025] [SWS_SwCluC_03026] [SWS_SwCluC_03027] [SWS_SwCluC_03028] [SWS_SwCluC_03033] [SWS_SwCluC_03034] [SWS_SwCluC_03035] [SWS_SwCluC_03036] [SWS_SwCluC_03037] [SWS_SwCluC_03038] [SWS_SwCluC_03039] [SWS_SwCluC_03040] [SWS_SwCluC_03041] [SWS_SwCluC_03042] [SWS_SwCluC_03043] [SWS_SwCluC_03044] [SWS_SwCluC_03045] [SWS_SwCluC_03046] [SWS_SwCluC_03047] [SWS_SwCluC_03058] [SWS_SwCluC_03060] [SWS_SwCluC_03061] [SWS_SwCluC_03068] [SWS_SwCluC_03073] [SWS_SwCluC_03074] [SWS_SwCluC_03076] [SWS_SwCluC_03077] [SWS_SwCluC_03101] [SWS_SwCluC_03120] [SWS_SwCluC_03133] [SWS_SwCluC_03142] [SWS_SwCluC_03150] [SWS_SwCluC_03153] [SWS_SwCluC_03156] [SWS_SwCluC_03159] [SWS_SwCluC_03164] [SWS_SwCluC_03165] [SWS_SwCluC_03166] [SWS_SwCluC_03167] [SWS_SwCluC_03168] [SWS_SwCluC_03169] [SWS_SwCluC_03170] [SWS_SwCluC_03171] [SWS_SwCluC_03173] [SWS_SwCluC_03177] [SWS_SwCluC_03201] [SWS_SwCluC_03202] [SWS_SwCluC_03204] [SWS_SwCluC_03209] [SWS_SwCluC_03212] [SWS_SwCluC_03214] [SWS_SwCluC_03215] [SWS_SwCluC_03217] [SWS_SwCluC_03218] [SWS_SwCluC_10000] [SWS_SwCluC_10001] [SWS_SwCluC_10002] [SWS_SwCluC_10003] [SWS_SwCluC_10004] [SWS_SwCluC_10005] [SWS_SwCluC_10006] [SWS_SwCluC_10007] [SWS_SwCluC_10008] [SWS_SwCluC_10009] [SWS_SwCluC_10010] [SWS_SwCluC_10011] [SWS_SwCluC_10020]

[SWS_SwCluC_10021] [SWS_SwCluC_10022] [SWS_SwCluC_10023] [SWS_SwCluC_10032] [SWS_SwCluC_10033] [SWS_SwCluC_10034] [SWS_SwCluC_11000] [SWS_SwCluC_11001] [SWS_SwCluC_12000] [SWS_SwCluC_12100] [SWS_SwCluC_12200] [SWS_SwCluC_12300] [SWS_SwCluC_12400] [SWS_SwCluC_13000] [SWS_SwCluC_13001] [SWS_SwCluC_13002] [SWS_SwCluC_13003] [SWS_SwCluC_13004] [SWS_SwCluC_13005] [SWS_SwCluC_13006] [SWS_SwCluC_13007] [SWS_SwCluC_13008] [SWS_SwCluC_13009] [SWS_SwCluC_13010] [SWS_SwCluC_13011] [SWS_SwCluC_13012] [SWS_SwCluC_13013] [SWS_SwCluC_13014] [SWS_SwCluC_13015] [SWS_SwCluC_90000] [SWS_SwCluC_90001] [SWS_SwCluC_90002] [SWS_SwCluC_90003] [SWS_SwCluC_90004] [SWS_SwCluC_90005] [SWS_SwCluC_90006] [SWS_SwCluC_90007] [SWS_SwCluC_90008] [SWS_SwCluC_90009] [SWS_SwCluC_90010] [SWS_SwCluC_90011] [SWS_SwCluC_90012] [SWS_SwCluC_90013] [SWS_SwCluC_90014] [SWS_SwCluC_90015] [SWS_SwCluC_90016] [SWS_SwCluC_90017] [SWS_SwCluC_90018] [SWS_SwCluC_90019] [SWS_SwCluC_90020] [SWS_SwCluC_90021] [SWS_SwCluC_90022] [SWS_SwCluC_CONSTR_02135] [SWS_SwCluC_CONSTR_02203] [SWS_SwCluC_CONSTR_02427] [SWS_SwCluC_CONSTR_02546] [SWS_SwCluC_CONSTR_02547] [SWS_SwCluC_CONSTR_02653] [SWS_SwCluC_CONSTR_02659] [SWS_SwCluC_CONSTR_02721] [SWS_SwCluC_CONSTR_03020] [SWS_SwCluC_CONSTR_03021] [SWS_SwCluC_CONSTR_03032] [SWS_SwCluC_CONSTR_03053] [SWS_SwCluC_CONSTR_03059] [SWS_SwCluC_CONSTR_03066] [SWS_SwCluC_CONSTR_03067] [SWS_SwCluC_CONSTR_03211]

F.3.3 Deleted Traceables in R22-11

[SWS_SwCluC_00999] [SWS_SwCluC_03151] [SWS_SwCluC_03157] [SWS_SwCluC_03174] [SWS_SwCluC_03175] [SWS_SwCluC_CONSTR_02228] [SWS_SwCluC_CONSTR_02229] [SWS_SwCluC_CONSTR_02230]