

<b>Document Title</b>	Specification of FlexRay ISO Transport Layer
<b>Document Owner</b>	AUTOSAR
<b>Document Responsibility</b>	AUTOSAR
<b>Document Identification No</b>	589
<b>Document Status</b>	published
<b>Part of AUTOSAR Standard</b>	Classic Platform
<b>Part of Standard Release</b>	R22-11

<b>Document Change History</b>			
<b>Date</b>	<b>Release</b>	<b>Changed by</b>	<b>Change Description</b>
2022-11-24	R22-11	AUTOSAR Release Management	<ul style="list-style-type: none"> <li>No content changes</li> </ul>
2021-11-25	R21-11	AUTOSAR Release Management	<ul style="list-style-type: none"> <li>No content changes</li> </ul>
2020-11-30	R20-11	AUTOSAR Release Management	<ul style="list-style-type: none"> <li>Removed SWS_FrTp_01132, SWS_FrTp_01111</li> <li>SWS_FrTp_01106 moved to Chapter 7.4</li> <li>Structure of Chapter 7.7 changed.</li> </ul>
2019-11-28	R19-11	AUTOSAR Release Management	<ul style="list-style-type: none"> <li>Header file name changes in Chapter 8.</li> <li>Changed Document Status from Final to published.</li> </ul>
2018-10-31	4.4.0	AUTOSAR Release Management	<ul style="list-style-type: none"> <li>Header File Cleanup</li> <li>Resolved inconsistent behavior of BSW modules in un-initialized state</li> </ul>

<b>Document Change History</b>			
<b>Date</b>	<b>Release</b>	<b>Changed by</b>	<b>Change Description</b>
2017-12-08	4.3.1	AUTOSAR Release Management	<ul style="list-style-type: none"> <li>• Removed HIS from acronym table in Section 2 and reference to HIS MISRA subset from Section 3.2</li> <li>• For Rollout of Runtime errors:               <ol style="list-style-type: none"> <li>a. DET errors FRTP_E_SEG_ERROR and FRTP_E_NO_CHANNEL are moved to new section called 'Runtime Errors' (SWS_FrTp_01208).</li> <li>b. Updated requirements SWS_FrTp_01187, SWS_FrTp_01068, SWS_FrTp_01185, SWS_FrTp_01186.</li> </ol> </li> </ul>
2016-11-30	4.3.0	AUTOSAR Release Management	<ul style="list-style-type: none"> <li>• Removed configuration parameters FrTpMaxBufferSize, FrTpMaxAs, FrTpMaxAr, FrTpMaxFrIf, FrTpTimeFrIf, FrTpTimeoutBr, FrTpTimeoutCs.</li> <li>• Addressing in Upper Layers using MetaData.</li> <li>• Introduced reliable TxConfirmation.</li> <li>• Editorial changes.</li> </ul>
2015-07-31	4.2.2	AUTOSAR Release Management	<ul style="list-style-type: none"> <li>• Updated the SWS requirements for DET renaming.</li> <li>• Updated the SWS requirement SWS_FrTp_01047 and added a note for the Tx Pdu processing.</li> </ul>

Document Change History			
Date	Release	Changed by	Change Description
2014-10-31	4.2.1	AUTOSAR Release Management	<ul style="list-style-type: none"> <li>Added FRTP_TIME_CS in table 2, FRTP_TIMEOUT_BR and FRTP_TIMEOUT_CS in table3.</li> <li>Updated for "Use cases for NULL_PTR in CopyRxData and CopyTxData should be allowed".</li> <li>Updated SWS_FrTp_01132, SWS_FrTp_01140, SWS_FrTp_01146, SWS_FrTp_01148, SWS_FrTp_01150 for FRTP_E_PARAM_POINTER.</li> <li>Added FRTP_E_INIT_FAILED in the SWS_FrTp_01132 (table).</li> </ul>
2014-03-31	4.1.3	AUTOSAR Release Management	<ul style="list-style-type: none"> <li>Modified ECUC_FrTp_00024, SWS_FrTp_00150, SWS_FrTp_00152, SWS_FrTp_00153, SWS_FrTp_01092, SWS_FrTp_01141, SWS_FrTp_01147, SWS_FrTp_01148, SWS_FrTp_01149.</li> <li>Added description in the section 7.5.4 Buffer Handling.</li> <li>Modified chapter 8.6.2.1 name to Development Error Tracer.</li> <li>Editorial changes.</li> </ul>
2013-10-31	4.1.2	AUTOSAR Release Management	<ul style="list-style-type: none"> <li>Removed requirement SWS_FrTp_01166</li> <li>Removed chapter 8.2.1, 8.2.1.1</li> <li>Removed chapter 7.5.4.2</li> <li>Modified SWS_FrTp_01149</li> <li>Added new requirement describing the layout of BC parameter</li> <li>Editorial changes</li> <li>Removed chapter(s) on change documentation</li> </ul>

<b>Document Change History</b>			
<b>Date</b>	<b>Release</b>	<b>Changed by</b>	<b>Change Description</b>
2013-03-15	4.1.1	AUTOSAR Administration	<ul style="list-style-type: none"> <li>• Corrected Retry Handling Mechanism</li> <li>• Clarified usage of BUFREQ_E_BUSY</li> <li>• Removed references to ChangeParameterConfirmation</li> <li>• Removed private values in NotifResultType</li> <li>• Changes to support Harmonization of ECU Parameters concept</li> <li>• Updated scope value of configuration parameters</li> </ul>
2011-12-22	4.0.3	AUTOSAR Administration	<ul style="list-style-type: none"> <li>• Renaming (ISO) and new UID (029=&gt;589)</li> <li>• API Names modified</li> </ul>
2010-09-30	3.1.5	AUTOSAR Administration	<ul style="list-style-type: none"> <li>• Time_CS removed from table 2</li> <li>• Add FrTp051 and Figure 24, Table 4 and Table 5 modified, renamed FrTpMaxBufReq to FrTpMaxFcWait, COUNTER_RX_BUFREQ and COUNTER_TX_BUFREQ removed</li> <li>• Transport Protocol supports data transfers of up to 2<sup>16</sup>-1 Bytes payload</li> <li>• Remove Chapter 7.5.4.3 with FrTp-1086 and FrTp-1087, remove COUNTER_BS, COUNTER_CR, Counter_TX_RN</li> </ul>
2010-02-02	3.1.4	AUTOSAR Administration	<ul style="list-style-type: none"> <li>• FrTp according to ISO 10681-2</li> <li>• New PduR API</li> <li>• Legal disclaimer revised</li> </ul>
2008-08-13	3.1.1	AUTOSAR Administration	<ul style="list-style-type: none"> <li>• Legal disclaimer revised</li> </ul>
2008-02-01	3.0.2	AUTOSAR Administration	<ul style="list-style-type: none"> <li>• Tables generated from UML-models, UML-diagrams linked to UML-model, general improvements of requirements in preparation of CT-development. No changes in the technical contents of the specification.</li> </ul>

<b>Document Change History</b>			
<b>Date</b>	<b>Release</b>	<b>Changed by</b>	<b>Change Description</b>
2007-12-21	3.0.1	AUTOSAR Administration	<ul style="list-style-type: none"><li>• Clarified the role and purpose of the functions PduR_FrTpChangeParameterConfirmation() and PduR_FrTpCancelTransmitConfirmation() with respect to the PDU Router.</li><li>• Document meta information extended</li><li>• Small layout adaptations made</li></ul>
2006-05-16	2.0	AUTOSAR Administration	<ul style="list-style-type: none"><li>• Document structure adapted to common Release 2.0 SWS Template.</li></ul>
2005-05-31	1.0	AUTOSAR Administration	<ul style="list-style-type: none"><li>• Initial Release</li></ul>

## Disclaimer

This work (specification and/or software implementation) and the material contained in it, as released by AUTOSAR, is for the purpose of information only. AUTOSAR and the companies that have contributed to it shall not be liable for any use of the work.

The material contained in this work is protected by copyright and other types of intellectual property rights. The commercial exploitation of the material contained in this work requires a license to such intellectual property rights.

This work may be utilized or reproduced without any modification, in any form or by any means, for informational purposes only. For any other purpose, no part of the work may be utilized or reproduced, in any form or by any means, without permission in writing from the publisher.

The work has been developed for automotive applications only. It has neither been developed, nor tested for non-automotive applications.

The word AUTOSAR and the AUTOSAR logo are registered trademarks.

## Table of Contents

1	Introduction and functional overview .....	10
2	Acronyms and abbreviations .....	13
3	Related documentation .....	15
3.1	Input documents.....	15
3.2	Related standards and norms.....	16
3.3	Related specification.....	16
4	Constraints and assumptions .....	17
4.1	Limitations .....	17
4.2	Applicability to car domains .....	17
4.3	Restriction to ISO 10681-2 .....	17
5	Dependencies to other modules .....	18
5.1	FlexRay Transport Layer interactions.....	18
5.2	PDU Router .....	19
5.3	FlexRay Interface .....	20
5.4	ECU State Manager .....	20
5.5	Default Error Tracing.....	20
5.6	File structure .....	22
5.6.1	Code file structure .....	22
5.6.2	Header file structure .....	22
5.6.3	Design rules.....	22
6	Requirements traceability .....	23
7	Functional specification .....	26
7.1	FrTp usage scenarios .....	26
7.2	FrTp behavior according to ISO10681-2 .....	27
7.2.1	Protocol Data Unit (PDU) .....	27
7.2.2	Frame Sequence charts.....	27
7.2.3	Limitation to ISO10681-2 .....	32
7.3	Internal Module behavior specification .....	33
7.3.1	Overview.....	33
7.3.2	Configuration data .....	34
7.3.3	Runtime data .....	36
7.4	Initialization and shutdown.....	41
7.5	Data Transfer Processing .....	43
7.5.1	Flags.....	43
7.5.2	Transmit Data .....	45
7.5.3	Receive Data .....	55
7.5.4	Buffer Handling.....	60
7.5.5	Dynamic Bandwidth Assignment .....	61
7.5.6	Transmit Cancellation .....	64
7.5.7	Change FrTp Parameter .....	66
7.5.8	Timing parameter and timeout behaviour .....	67
7.6	Counters.....	72
7.7	Error Classification .....	74

7.7.1	Development Errors .....	74
7.7.2	Runtime Errors .....	74
7.7.3	Transient Faults.....	75
7.7.4	Production Errors .....	75
7.7.5	Extended Production Errors .....	75
8	API specification .....	76
8.1	Imported types .....	76
8.2	Type definitions.....	77
8.2.1	FrTp_ConfigType .....	77
8.3	Function definitions .....	77
8.3.1	Standard functions .....	77
8.3.2	Initialization and Shutdown .....	78
8.3.3	Normal Operation .....	79
8.4	Call-back notifications .....	83
8.4.1	FrTp_TriggerTransmit .....	83
8.4.2	FrTp_RxIndication .....	84
8.4.3	FrTp_TxConfirmation .....	85
8.5	Scheduled functions.....	86
8.5.1	FrTp_MainFunction .....	86
8.6	Expected Interfaces .....	87
8.6.1	Mandatory Interfaces.....	87
8.6.2	Optional Interfaces .....	88
8.6.3	Configurable interfaces .....	88
9	Sequence diagrams .....	89
9.1	Sending of N-Pdus.....	89
9.2	Receiving of N-Pdus .....	90
10	Configuration specification.....	91
10.1	How to read this chapter .....	91
10.2	Containers and configuration parameters .....	92
10.2.1	FrTp .....	92
10.2.2	FrTpGeneral .....	93
10.2.3	FrTpMultipleConfig .....	100
10.2.4	FrTpConnection.....	101
10.2.5	FrTpTxSdu.....	106
10.2.6	FrTpRxSdu .....	108
10.2.7	FrTpConnectionControl .....	109
10.2.8	FrTpTxPduPool .....	115
10.2.9	FrTpRxPduPool.....	116
10.2.10	FrTpTxPdu.....	117
10.2.11	FrTpRxPdu .....	118
10.3	Published Information .....	121
10.4	Configuration dependencies and recommendation.....	121
10.4.1	Retry behaviour .....	121
10.4.2	TP-Acknowledgement and Retry .....	121
10.4.3	Timing and Timeout Parameters.....	122
10.4.4	Bandwidth Control Configuration .....	122
10.4.5	Configuration Requirements on the FlexRay Interface.....	126



11 Not applicable requirements ..... 127

# 1 Introduction and functional overview

This specification describes the functionality, API, and the configuration of the AUTOSAR basic software module FlexRay Transport Protocol (FrTp).

According to the AUTOSAR layered software architecture [2] (see Figure 1), the FlexRay Transport Protocol (FrTp) is placed between the PDU Router module and the FlexRay Interface module. The main purpose of the FlexRay Transport Protocol is segmentation and reassembly of messages (I-PDUs) that do not fit in one of the assigned FlexRay L-PDUs.

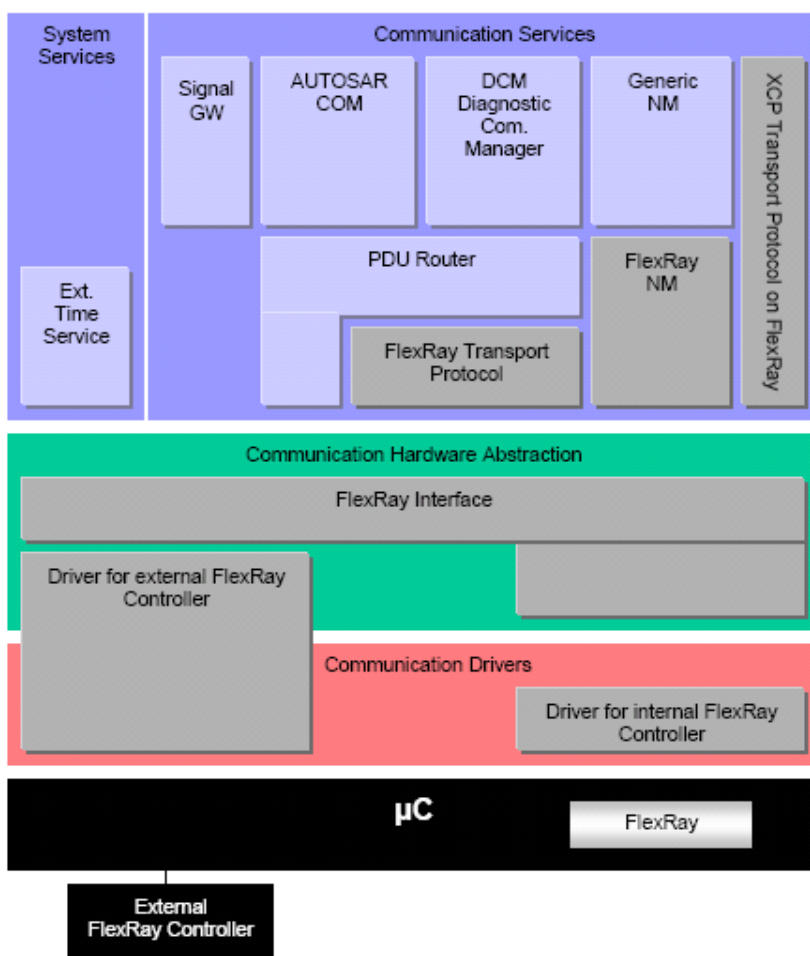

Figure 1: AUTOSAR FlexRay Layered Architecture

Figure 2 depicts the different PDU names in AUTOSAR nomenclature and the signal dependencies between the different AUTOSAR modules.

The PDU Router deploys upper Layers (e.g. COM, DCM etc) I-PDUs onto different communication protocols. The routing through a network system type (e.g. FlexRay, CAN, LIN etc.) depends on the I-PDU identifier. The PDU Router also determines (by configuration) if a transport protocol shall be used or not. Finally, this module carries out gateway functionality, when there is no rate conversion.

FlexRay Interface (FrIf) provides standardized mechanisms to access a FlexRay bus channel via a FlexRay Communication Controller regardless of its location (µC

internal/external). Depending on the PDU ID, the FlexRay Interface has to forward an N-PDU to FrTp or an I-PDU to PduR. The FrTp handles only transport protocol N-PDUs (i.e. SF, CF, LF and FC PDUs).

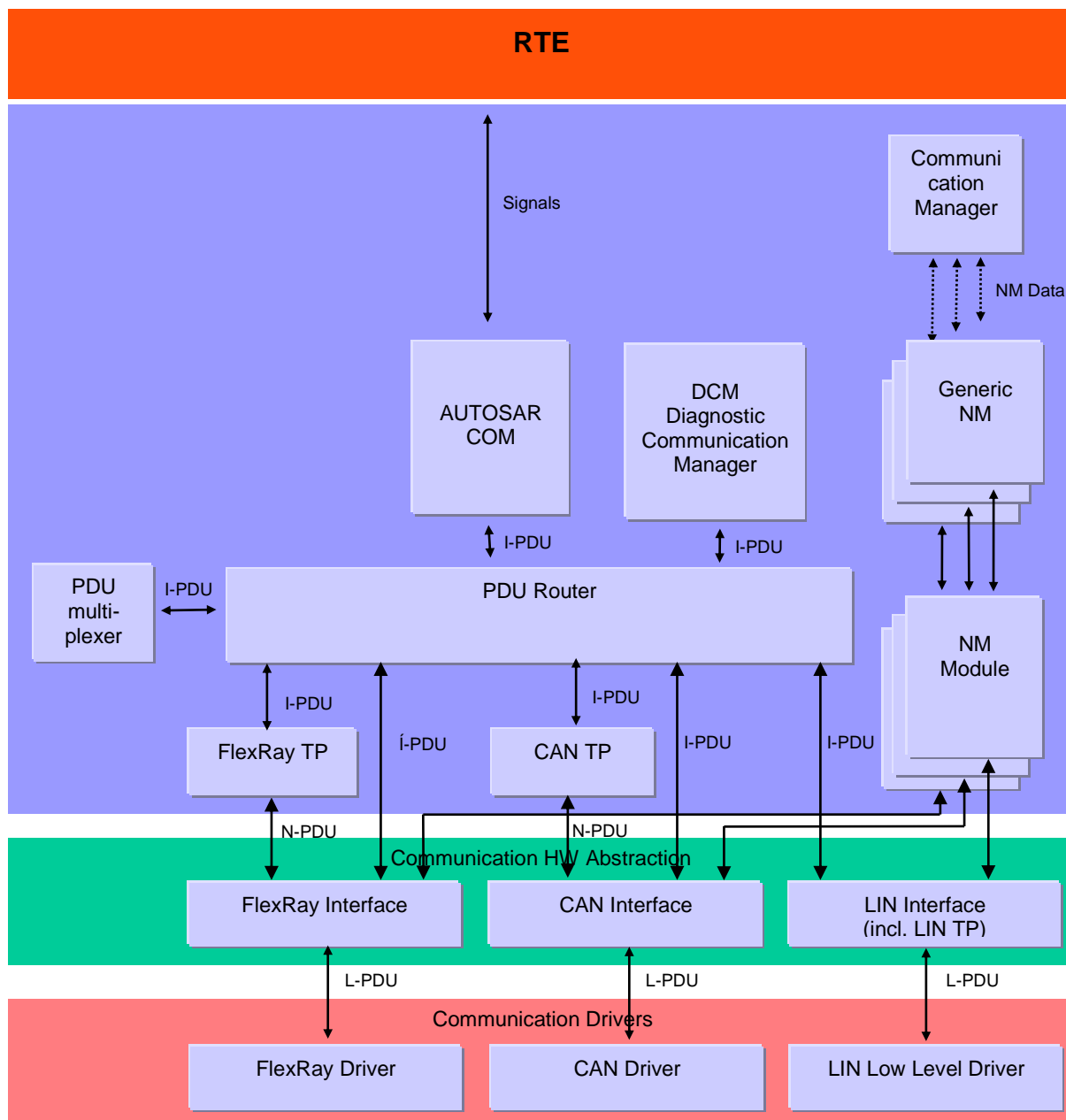

Figure 2 : AUTOSAR Signal Nomenclature

The main purpose of FlexRay Transport Protocol is to perform a transfer of a message (I-PDU) that e.g. might or might not fit in a single FlexRay L-PDU. I-PDUs that do not fit into a single FlexRay L-PDU are segmented into multiple parts, where each can be transmitted in a FlexRay L-PDU. According to AUTOSAR basic software architecture, the FlexRay Transport Protocol provides methods for

- Segmentation of data in transmit direction
- Reassembling of data in receive direction
- Control of data flow
- Error detection in segmentation sessions

- Transmit cancellation

It is an AUTOSAR decision to base basic software module specifications on existing standards, thus this AUTOSAR FlexRay Transport Layer specification is based on the international standard ISO 10681-2 [16]. This standard provides

- Transmission of a message with known message length
- Transmission of a message with unknown but finite message length
- Acknowledgement of transmission with retry mechanism

The FlexRay Transport Protocol supports 1:1 and 1:n connections.

The FlexRay Transport Protocol supports data transfers of up to  $2^{16}-1$  Bytes payload.

FlexRay Transport Protocol is mainly used for vehicle diagnostic systems. Nevertheless, it was developed to deal with requirements from other FlexRay based systems requiring a Transport Protocol Layer protocol (e.g. Diagnostic communication, Inter-ECU communication, XCP communication etc.).

## 2 Acronyms and abbreviations

The prefix notation used in this document, is as follows:

<b>Prefix:</b>	<b>Description:</b>
I-	Relative to upper AUTOSAR Layer (e.g. COM, DCM etc.)
L-	Relative to the FlexRay Interface module.
N-	Relative to the FlexRay Transport Protocol Layer.

All acronyms and abbreviations, which are specific to the FlexRay Transport Layer and are therefore not contained in the AUTOSAR glossary are described in the following:

<b>Acronym:</b>	<b>Description:</b>
Fr L-SDU	This is the SDU of the FlexRay Interface module. It is similar to Fr N-PDU but from the FlexRay Interface module point of view.
Fr L-Sduld	This is the unique identifier of a Fr-L-SDU within the FlexRay Interface. It is used for referencing L-SDU's routing properties.
Fr N-PDU	This is the PDU of the FlexRay Transport Layer. It contains address information, protocol control information and data (the whole Fr N-SDU or a part of it).
Fr N-SDU	This is the SDU of the FlexRay Transport Layer. In the AUTOSAR architecture, it is a set of data coming from the PDU Router.
Fr N-Sduld	Unique N-SDU identifier within the FlexRay Transport Layer. It is used to reference N-SDU's routing properties.
I-PDU	This is the PDU of the upper AUTOSAR Layers modules (e.g. COM, DCM etc.). If data transfer via FlexRay Transport Protocol is configured, I-PDU is similar to an FrTp N-SDU.
PDU	In layered systems, it refers to a data unit that is specified in the protocol of a given layer. This contains user data of that layer (SDU) plus possible protocol control information. Furthermore, the PDU of layer X is the SDU of its lower layer X-1 (i.e. (X)-PDU = (X-1)-SDU).
PduInfoType	This type refers to a structure used to store basic information to process the transmission\reception of a PDU (or a SDU), namely a pointer to its payload in RAM and the corresponding length (in bytes).
Channel	A channel is a resource of the FrTp module to handle communication links to other communication nodes from FrTp's point of view (transferring Fr N-PDUs).
Connection	A connection specifies a communication link between different communication nodes from FrTp's point of view. A connection defines the sender / receiver relation of communication nodes
PCI	Protocol Control Information
e.g.	lat. 'exempli gratia' – engl. for example
i.e.	lat. 'id est' – engl. that is
CanTp	CAN Transport Protocol
LinTp	LIN Transport Protocol
CF	Consecutive Frame Fr N-PDU
COM	AUTOSAR Communications module
DCM	Diagnostic Communication Manager module
DET	Default Error Tracer
FC	Flow Control Fr N-PDU
Fr	FlexRay Driver module
FrIf	FlexRay Interface module
FrTp	FlexRay Transport Protocol Layer
PduR	PDU Router
SF	Start Frame Fr N-PDU
LF	Last Frame Fr N-PDU
TP	Transport Protocol Layer

<b>Acronym:</b>	<b>Description:</b>
SDU	In layered systems, this refers to a set of data that is sent by a user of the services of a given layer, and is transmitted to a peer service user, whilst remaining semantically unchanged.
AUTOSAR	Automotive Open System Architecture
SWS	Software Specification
MISRA	Motor Industry Software Reliability Association
ISO	International Standard Organisation
ID	Identifier
OS	Operating System
MCAL	Microcontroller Abstraction Layer
CPU	Central Processing Unit
ROM	Read Only Memory
RAM	Random Access Memory
STF	Start Frame (please refer to ISO 10681-2)
AF	Acknowledge Frame (please refer to ISO 10681-2)
SN	Sequence Number (please refer to ISO 10681-2)
FrTp_As	Timer Parameter for a sender. Time for transmission of the FlexRay frame (any N_PDU) on the sender side. (please refer to ISO 10681-2)
FrTp_Ar	Timer Parameter for a receiver. Time for transmission of the FlexRay frame (any N_PDU) on the receiver side (please refer to ISO 10681-2)
FrTp_BS	Timer Parameter for a sender. Time until reception of the next FlowControl N_PDU. (please refer to ISO 10681-2)
FrTp_Br	Timer Parameter for a receiver. Time until transmission of the next FlowControl N_PDU. (please refer to ISO 10681-2)
FrTp_Cs	Timer Parameter for a sender. Time until transmission of the next ConsecutiveFrame N_PDU/LastFrame N_PDU. (please refer to ISO 10681-2)
FrTp_Cr	Timer Parameter for a receiver. Time until reception of the next ConsecutiveFrame N_PDU (please refer to ISO 10681-2)

## 3 Related documentation

### 3.1 Input documents

- [1] List of Basic Software Modules  
AUTOSAR\_TR\_BSWModuleList.pdf
- [2] Layered Software Architecture  
AUTOSAR\_EXP\_LayeredSoftwareArchitecture.pdf.pdf
- [3] General Requirements of Basic Software Modules  
AUTOSAR\_SRS\_BSWGeneral.pdf
- [4] Requirements on FlexRay  
AUTOSAR\_SRS\_FlexRay.pdf
- [5] Specification of FlexRay Interface  
AUTOSAR\_SWS\_FlexRayInterface.pdf
- [6] Specification of PDU Router  
AUTOSAR\_SWS\_PDURouter.pdf
- [7] Specification of Communication Stack Types  
AUTOSAR\_SWS\_CommunicationStackTypes.pdf
- [8] Specification of Standard Types  
AUTOSAR\_SWS\_StandardTypes.pdf
- [9] Specification of Platform Types  
AUTOSAR\_SWS\_PlatformTypes.pdf
- [10] Basic Software Module Description Template,  
AUTOSAR\_TPS\_BSWModuleDescriptionTemplate.pdf
- [11] Specification of ECU Configuration,  
AUTOSAR\_TPS\_ECUConfiguration.pdf
- [12] Specification of Diagnostic Event Manager,  
AUTOSAR\_SWS\_DiagnosticEventManager.pdf
- [13] Specification of Default Error Tracer,  
AUTOSAR\_SWS\_DefaultErrorTracer.pdf
- [14] General Specification of Basic Software Modules  
AUTOSAR\_SWS\_BSWGeneral.pdf

### **3.2 Related standards and norms**

- [15] FlexRay Communications System Protocol Specification Version 2.1
- [16] ISO10681-2, Road vehicles – Communication on FlexRay – Part 2:  
Communication Layer services

### **3.3 Related specification**

AUTOSAR provides a General Specification on Basic Software modules [14] (SWS BSW General), which is also valid for FlexRay ISO Transport Layer.

Thus, the specification SWS BSW General shall be considered as additional and required specification for FlexRay ISO Transport Layer.



## 4 Constraints and assumptions

### 4.1 Limitations

The AUTOSAR architecture defines communication system specific transport protocol layers (FrTp, CanTp, LinTp etc.). Thus, the FlexRay Transport Protocol layer (FrTp) only covers FlexRay transport protocol specifics.

The FlexRay Transport Protocol has an interface to a single underlying FlexRay Interface Layer and a single upper PDU Router module.

### 4.2 Applicability to car domains

The FlexRay module can always be used for applications if the FlexRay protocol was used.

### 4.3 Restriction to ISO 10681-2

The AUTOSAR FrTp module does not support ISO 10681-2 functionalities as listed below:

Functionality	Description
Status monitoring	ISO 10681-2 provides the functionality to monitor the status of an active data transfer. Thus, the ISO-10681-2 API provides the service primitives C_GetStatus.request and C_GetStatus.confirm.
Read Communication Parameter values	ISO 10681-2 provides the functionality to read out current communication parameter values. Thus, the ISO-10681-2 API provides the service primitives C_GetParameters.request and C_GetParameters.confirm.

Table 1: Limitation of AUTOSAR FrTp vs. ISO 10681-2

## 5 Dependencies to other modules

This section sets out relations between the FlexRay Transport Protocol (FrTp) and other AUTOSAR basic software modules. It contains brief descriptions of the services, which are required by the FrTp from other modules or which are required by other modules from the FrTp.

### 5.1 FlexRay Transport Layer interactions

The FrTp's upper interface offers the PduR module global access, to transmit and receive data (Fr N-SDU). FlexRay N-SDU identifiers (Fr N-SDU-ID) achieve this access. FlexRay N-SDU-ID refers to a constant data structure that consists of attributes describing FlexRay N-SDU. The figure below shows the interactions between FrTp, PduR and FrIf modules.

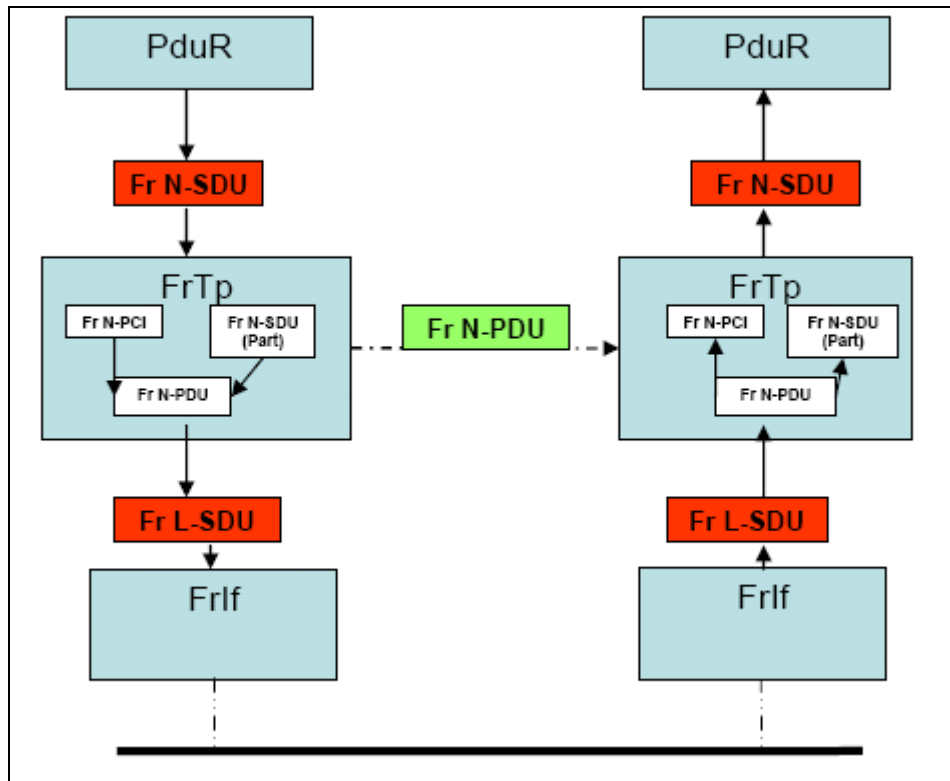

Figure 3: FrTp interactions

## 5.2 PDU Router

The FrTp module requests different services primitives provided by the PDU Router module. The requested services primitives of the PDU-Router module are listed below. For further details please refer to chapter 8.6 and specification [6]:

- ***PduR\_FrTpStartOfReception***  
By this API service primitive, the FrTp indicates the start of reception of a FrTp-I-PDU.
- ***PduR\_FrTpCopyRxData***  
By this API service primitive, the FrTp initiates the copy process of the received FrTp N-PDU payload data to a provided <Upper Layer> Rx buffer
- ***PduR\_FrTpRxIndication***  
By this API service primitive, the FrTp indicates the completed (un)successful reception of an FrTp-I-PDU.
- ***PduR\_FrTpCopyTxData***  
By this API service primitive, the FrTp initiates the copy process of the FrTp N-PDU payload data from the provided <Upper Layer> Tx buffer
- ***PduR\_FrTpTxConfirmation***  
By this API service primitive, the FrTp module confirms the (un)successful sending of the complete Fr N-SDU to the corresponding sender module (e.g. COM, DCM etc).

The following services primitives of the FrTp module are called by the PDU-Router:

- ***FrTp\_Transmit***  
By this API service primitive, an upper layer initiates a I-PDU data transfer via PDU-Router
- ***FrTp\_CancelTransmit***  
By this API service primitive, sending of an Fr N-SDU is cancelled on sender site.
- ***FrTp\_ChangeParameter***  
By this API service primitive, some communication parameters of the FrTp module could be changed.
- ***FrTp\_CancelReceive***  
By this API service primitive, an ongoing reception could be canceled.

### 5.3 FlexRay Interface

The following services primitives of the FlexRay Interface (Frlf) module are called by the FrTp:

- ***Frlf\_Transmit***  
By this API service primitive, the transfer of an Fr N-PDU is initiated.

The following services primitives of the FrTp module are called by the FlexRay Interface module:

- ***FrTp\_RxIndication***  
By this API service primitive, the FlexRay Interface module indicates the reception of an FrTp frame (Fr N-PDU, not to be confused with a FlexRay frame) to the FrTp. The FrTp then processes this frame.
- ***FrTp\_TxConfirmation***  
By this API service primitive, the FlexRay Interface module confirms the sending of the frame containing the Fr N-PDU with result (E\_OK if the transmission was successful, E\_NOT\_OK if the transmission failed) over the FlexRay network.
- ***FrTp\_TriggerTransmit***  
By this API service primitive, the FlexRay Interface get access to the Fr N-PDU data.<sup>1</sup>

### 5.4 ECU State Manager

The following services primitives of the FrTp module are called by the ECU State Manager module (SWS\_EcuM\_02859):

- ***FrTp\_Init***  
By this API service primitive, the FrTp module is initialized.
- ***FrTp\_Shutdown***  
By this API service primitive, all active communication links are closed, resources are freed and the module is stopped.

### 5.5 Default Error Tracing

The following services primitives of the Default Error Tracing module are called by the FrTp module:

---

<sup>1</sup> Depending on the configured buffer access mode.

- ***Det\_ReportError***  
By this API service primitive, the FrTp module reports development errors.

## 5.6 File structure

### 5.6.1 Code file structure

For details refer to the chapter 5.1.6 “Code file structure” in SWS\_BSWGeneral.

### 5.6.2 Header file structure

**[SWS\_FrTp\_01157]** 「FrTp.h shall contain all data exported from the FrTp – API declarations, callbacks, extern types and global data.」()

### 5.6.3 Design rules

**[SWS\_FrTp\_00209]** 「The source code of the FrTp module shall be neither compiler (tool) nor platform (processor) dependent.<sup>2</sup>」()

**[SWS\_FrTp\_01129]** 「The FlexRay Transport Layer module architecture shall support configuration modification by a dedicated update process (e.g. flash reprogramming)」(SRS\_Fr\_05123)

---

<sup>2</sup> No compiler specific keywords shall be used.  
22 of 127

## 6 Requirements traceability

Requirement	Description	Satisfied by
SRS_BSW_00005	Modules of the \mu C Abstraction Layer (MCAL) may not have hard coded horizontal interfaces	SWS_FrTp_NA_09999
SRS_BSW_00006	The source code of software modules above the \mu C Abstraction Layer (MCAL) shall not be processor and compiler dependent.	SWS_FrTp_NA_09999
SRS_BSW_00009	All Basic SW Modules shall be documented according to a common standard.	SWS_FrTp_NA_09999
SRS_BSW_00010	The memory consumption of all Basic SW Modules shall be documented for a defined configuration for all supported platforms.	SWS_FrTp_NA_09999
SRS_BSW_00101	The Basic Software Module shall be able to initialize variables and hardware in a separate initialization function	SWS_FrTp_00147
SRS_BSW_00159	All modules of the AUTOSAR Basic Software shall support a tool based configuration	SWS_FrTp_NA_09999
SRS_BSW_00160	Configuration files of AUTOSAR Basic SW module shall be readable for human beings	SWS_FrTp_NA_09999
SRS_BSW_00161	The AUTOSAR Basic Software shall provide a microcontroller abstraction layer which provides a standardized interface to higher software layers	SWS_FrTp_NA_09999
SRS_BSW_00162	The AUTOSAR Basic Software shall provide a hardware abstraction layer	SWS_FrTp_NA_09999
SRS_BSW_00164	The Implementation of interrupt service routines shall be done by the Operating System, complex drivers or modules	SWS_FrTp_NA_09999
SRS_BSW_00167	All AUTOSAR Basic Software Modules shall provide configuration rules and constraints to enable plausibility checks	SWS_FrTp_NA_09999
SRS_BSW_00168	SW components shall be tested by a function defined in a common API in the Basis-SW	SWS_FrTp_NA_09999
SRS_BSW_00172	The scheduling strategy that is built inside the Basic Software Modules shall be compatible with the strategy used in the system	SWS_FrTp_NA_09999
SRS_BSW_00306	AUTOSAR Basic Software Modules shall be compiler and platform independent	SWS_FrTp_NA_09999
SRS_BSW_00312	Shared code shall be reentrant	SWS_FrTp_NA_09999
SRS_BSW_00314	All internal driver modules shall separate the interrupt frame definition from the service routine	SWS_FrTp_NA_09999
SRS_BSW_00323	All AUTOSAR Basic Software Modules shall check passed API parameters for validity	SWS_FrTp_NA_09999
SRS_BSW_00325	The runtime of interrupt service routines and functions that are running in interrupt context shall be kept short	SWS_FrTp_NA_09999
SRS_BSW_00328	All AUTOSAR Basic Software Modules shall avoid the duplication of code	SWS_FrTp_NA_09999

SRS_BSW_00330	It shall be allowed to use macros instead of functions where source code is used and runtime is critical	SWS_FrTp_NA_09999
SRS_BSW_00331	All Basic Software Modules shall strictly separate error and status information	SWS_FrTp_NA_09999
SRS_BSW_00333	For each callback function it shall be specified if it is called from interrupt context or not	SWS_FrTp_NA_09999
SRS_BSW_00335	Status values naming convention	SWS_FrTp_NA_09999
SRS_BSW_00341	Module documentation shall contains all needed informations	SWS_FrTp_NA_09999
SRS_BSW_00343	The unit of time for specification and configuration of Basic SW modules shall be preferably in physical time unit	SWS_FrTp_NA_09999
SRS_BSW_00345	BSW Modules shall support pre-compile configuration	SWS_FrTp_NA_09999
SRS_BSW_00347	A Naming seperation of different instances of BSW drivers shall be in place	SWS_FrTp_NA_09999
SRS_BSW_00350	All AUTOSAR Basic Software Modules shall allow the enabling/disabling of detection and reporting of development errors.	SWS_FrTp_NA_09999
SRS_BSW_00358	The return type of init() functions implemented by AUTOSAR Basic Software Modules shall be void	SWS_FrTp_NA_09999
SRS_BSW_00373	The main processing function of each AUTOSAR Basic Software Module shall be named according the defined convention	SWS_FrTp_NA_09999
SRS_BSW_00375	Basic Software Modules shall report wake-up reasons	SWS_FrTp_NA_09999
SRS_BSW_00377	A Basic Software Module can return a module specific types	SWS_FrTp_NA_09999
SRS_BSW_00386	The BSW shall specify the configuration and conditions for detecting an error	SWS_FrTp_NA_09999
SRS_BSW_00401	Documentation of multiple instances of configuration parameters shall be available	SWS_FrTp_NA_09999
SRS_BSW_00405	BSW Modules shall support multiple configuration sets	SWS_FrTp_NA_09999
SRS_BSW_00407	Each BSW module shall provide a function to read out the version information of a dedicated module implementation	SWS_FrTp_00215
SRS_BSW_00409	All production code error ID symbols are defined by the Dem module and shall be retrieved by the other BSW modules from Dem configuration	SWS_FrTp_NA_09999
SRS_BSW_00410	Compiler switches shall have defined values	SWS_FrTp_NA_09999
SRS_BSW_00413	An index-based accessing of the instances of BSW modules shall be done	SWS_FrTp_NA_09999
SRS_BSW_00414	Init functions shall have a pointer to a configuration structure as single parameter	SWS_FrTp_NA_09999
SRS_BSW_00415	Interfaces which are provided exclusively for one module shall be separated into a dedicated header file	SWS_FrTp_NA_09999



SRS_BSW_00417	Software which is not part of the SW-C shall report error events only after the Dem is fully operational.	SWS_FrTp_NA_09999
SRS_BSW_00423	BSW modules with AUTOSAR interfaces shall be describable with the means of the SW-C Template	SWS_FrTp_NA_09999
SRS_BSW_00424	BSW module main processing functions shall not be allowed to enter a wait state	SWS_FrTp_NA_09999
SRS_BSW_00425	The BSW module description template shall provide means to model the defined trigger conditions of schedulable objects	SWS_FrTp_NA_09999
SRS_BSW_00426	BSW Modules shall ensure data consistency of data which is shared between BSW modules	SWS_FrTp_NA_09999
SRS_BSW_00427	ISR functions shall be defined and documented in the BSW module description template	SWS_FrTp_NA_09999
SRS_BSW_00428	A BSW module shall state if its main processing function(s) has to be executed in a specific order or sequence	SWS_FrTp_NA_09999
SRS_BSW_00429	Access to OS is restricted	SWS_FrTp_NA_09999
SRS_BSW_00432	Modules should have separate main processing functions for read/receive and write/transmit data path	SWS_FrTp_NA_09999
SRS_BSW_00433	Main processing functions are only allowed to be called from task bodies provided by the BSW Scheduler	SWS_FrTp_NA_09999
SRS_Fr_05073	The FlexRay Transport Layer shall be configured to be compliant with the ISO 10681-2 specification	SWS_FrTp_01005, SWS_FrTp_01006
SRS_Fr_05077	Each N-SDU shall have a unique identifier	SWS_FrTp_01018
SRS_Fr_05088	FlexRay Transport Layer's variables shall be initialized	SWS_FrTp_01034, SWS_FrTp_01035
SRS_Fr_05093	A cancellation service of transmission shall be provided at any time	SWS_FrTp_01005, SWS_FrTp_01006
SRS_Fr_05095	The FlexRay Transport Layer shall support the dynamic bandwidth control mechanism	SWS_FrTp_01005, SWS_FrTp_01006
SRS_Fr_05123	The Configuration shall be modifiable by a Flashing Process	SWS_FrTp_01129

## 7 Functional specification

This section provides a description of the FlexRay Transport Protocol Layer functionality. It explains the services provided to the upper and lower layers and the internal behavior of the FrTp Layer module.

The main purpose of the FlexRay Transport Protocol (FrTp) Layer is transferring messages (I-PDUs) that may or may not fit in a single FlexRay frame (L-PDU). The FrTp Layer module provides services for segmentation and reassembly of upper-layer messages (Fr N-SDUs). Hence FrTp module offers services for segmentation, transmission with flow control, and reassembly of messages.

While reading this document, it is necessary to bear in mind, that the Transport Protocol functionality (e.g. frame assembly, frame handling, error handling etc.) is according to ISO10681-2, Road vehicles – Communication on FlexRay – Part 2: Communication Layer services [16].

**[SWS\_FrTp\_01005]** If no explicit recommendation or requirement is defined, the FrTp module shall follow the specification ISO10681-2, Road vehicles – Communication on FlexRay – Part 2: Communication Layer services [16]. (SRS\_Fr\_05073, SRS\_Fr\_05093, SRS\_Fr\_05095)

Transport protocol facilities will be used to transport AUTOSAR I-PDUs from different source modules (e.g. COM, DCM etc.). Therefore, the FrTp module is able to deal with multiple connections simultaneously (i.e. multiple segmentation sessions in parallel).

The maximum number of simultaneous active connections is statically configured. This configuration has an important impact on complexity and resource consumption (CPU, ROM and RAM) of the code generated, because resources (e.g. Rx and Tx state machines, variables used to work on N-PCI data and so on) have to be reserved for each simultaneous access.

### 7.1 FrTp usage scenarios

As depicted in Figure 4, the FrTp module is usable within single Electronic Control Units (ECUs) as well as in Gateways. In both cases FrTp modules are responsible to handle communication via FlexRay but for gateway purpose some additional requirements have to be taken into account.

**Note:** Each time a special usage scenario has to be taken into account, a footnote is given within the document.

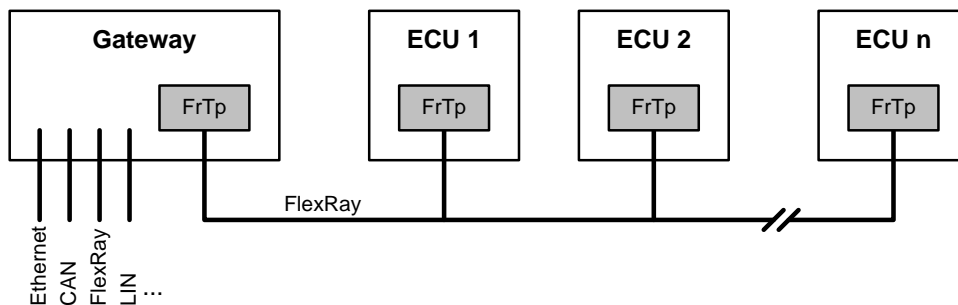

Figure 4: FrTp usage scenarios

## 7.2 FrTp behavior according to ISO10681-2

This chapter gives a small overview about the Transport Protocol behaviour and data transmission szenarios according to ISO 10681-2. This chapter is only for a better understanding of the software solution to fullfill ISO 10681-2 and specifies no additional requirement.

### 7.2.1 Protocol Data Unit (PDU)

**[SWS\_FrTp\_01006]** The FrTp module shall support the Fr N-PDU formats as defined in [16] ISO10681-2, Road vehicles – Communication on FlexRay – Part 2: Communication Layer services (SRS\_Fr\_05073, SRS\_Fr\_05093, SRS\_Fr\_05095)

### 7.2.2 Frame Sequence charts

This chapter describes the data transfer modes based on Transport Protocol Layer frame (N-PDU) sequences according to ISO10681-2. This is only for a better understanding of the FrTp internal work and shall not be an additional specification. For a final implementation only the figures in [16] ISO10681-2, Road vehicles – Communication on FlexRay – Part 2: Communication Layer services are relevant.

#### 7.2.2.1 Unsegmented unacknowledged data transfer with known message length

**[SWS\_FrTp\_01007]** According to ISO 10681-2 [16] the FrTp module shall support an unsegmented unacknowledged data transfer with known message length as depict in Figure 5.

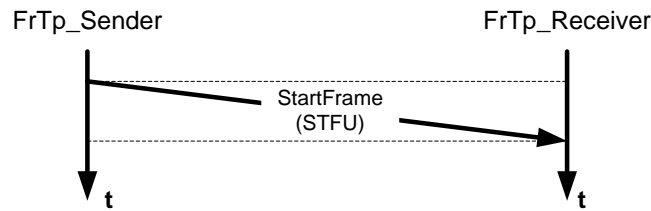

Figure 5: Frame sequence of an unsegmented unacknowledged data transfer with known message length  $\lceil()$

### 7.2.2.2 Unsegmented acknowledged data transfer with known message length

[SWS\_FrTp\_01008]  $\Gamma$  According to ISO 10681-2 [16] the FrTp module supports an unsegmented acknowledged data transfer with known message length as depict in Figure 6.

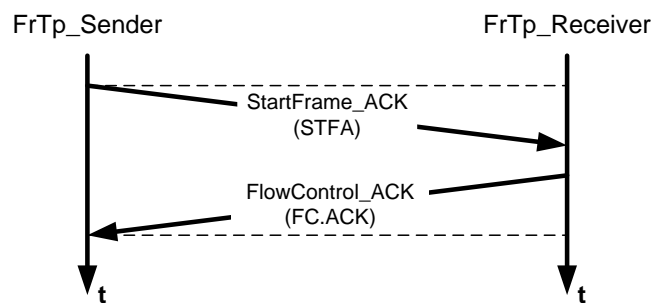
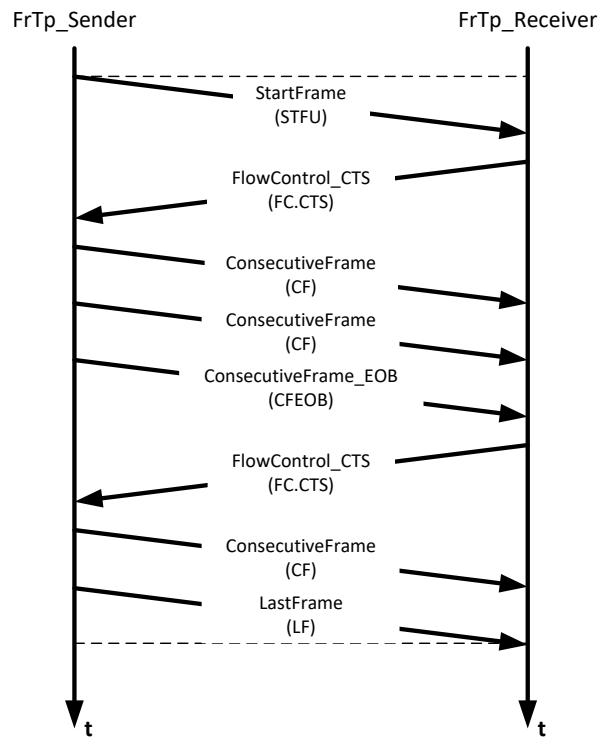

Figure 6: Frame sequence of an unsegmented acknowledged data transfer with known message length  $\lceil()$

### 7.2.2.3 Segmented unacknowledged data transfer with known message length

[SWS\_FrTp\_01009]  $\Gamma$  According to ISO 10681-2 [16] the FrTp module shall support a segmented unacknowledged data transfer with known message length as depict in Figure 7.



**Figure 7: Frame sequence a segmented unacknowledged data transfer with known message length<sub>j</sub>()**

**7.2.2.4 Segmented acknowledged data transfer with known message length**

**[SWS\_FrTp\_01010]** According to ISO 10681-2 [16] the FrTp module shall support a segmented acknowledged data transfer with known message length as depict in Figure 8.

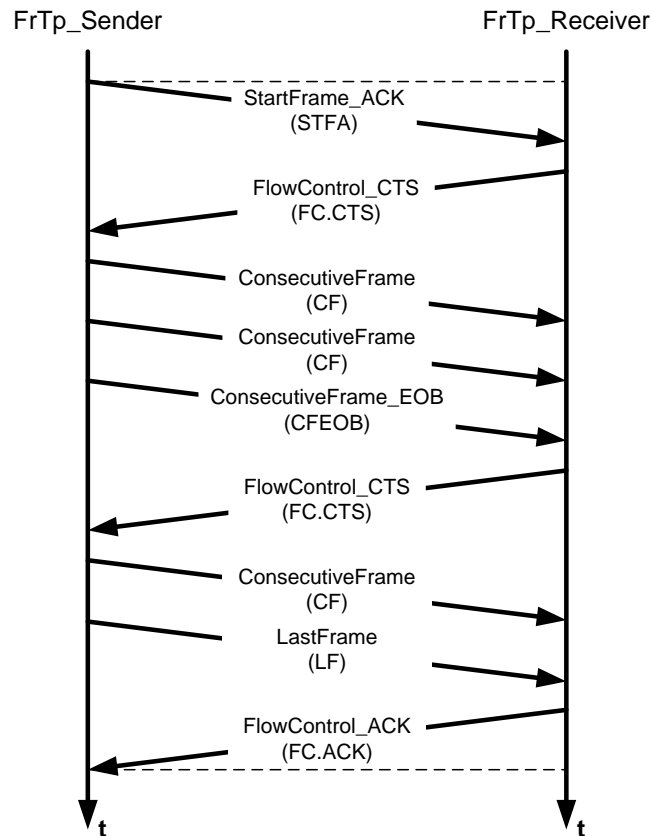

**Figure 8: Frame sequence of a segmented acknowledged data transfer with known message length<sub>j</sub>()**

### 7.2.2.5 Segmented unacknowledged data transfer with unknown message length

**[SWS\_FrTp\_01011]** According to ISO 10681-2 [16] the FrTp module shall support a segmented unacknowledged data transfer with unknown message length as depicted in Figure 9.

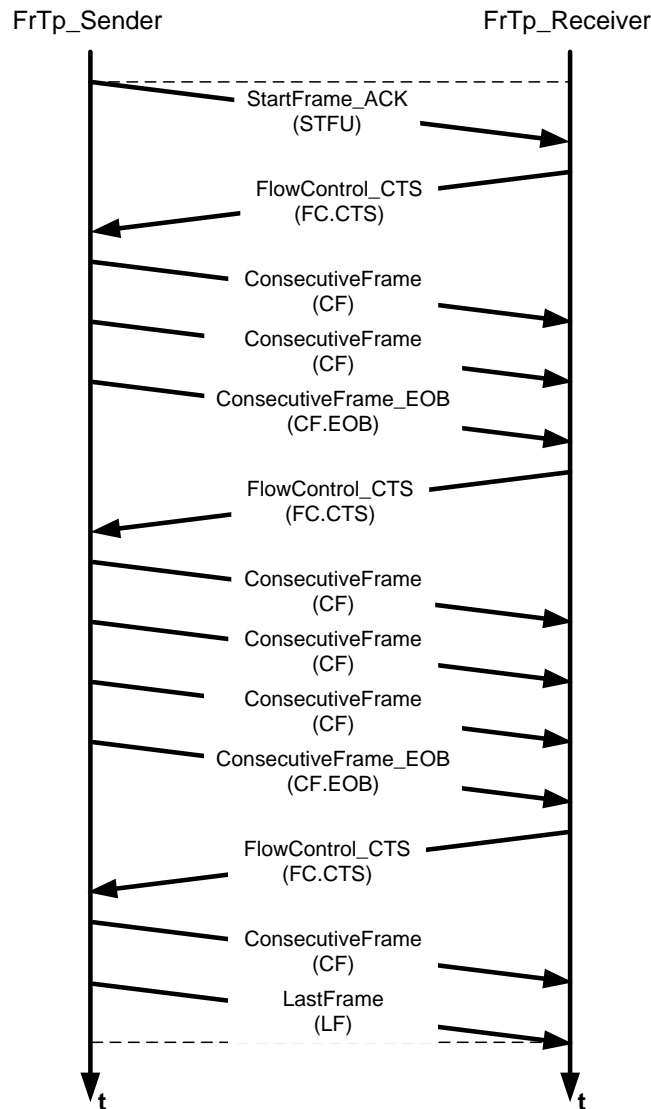

**Figure 9: Frame sequence of a segmented unacknowledged data transfer with unknown message length ]()**

**7.2.2.6 Segmented acknowledged data transfer with unknown message length**

**[SWS\_FrTp\_01012]** According to ISO 10681-2 [16] the FrTp module shall support a segmented acknowledged data transfer with unknown message length as depict in Figure 10.

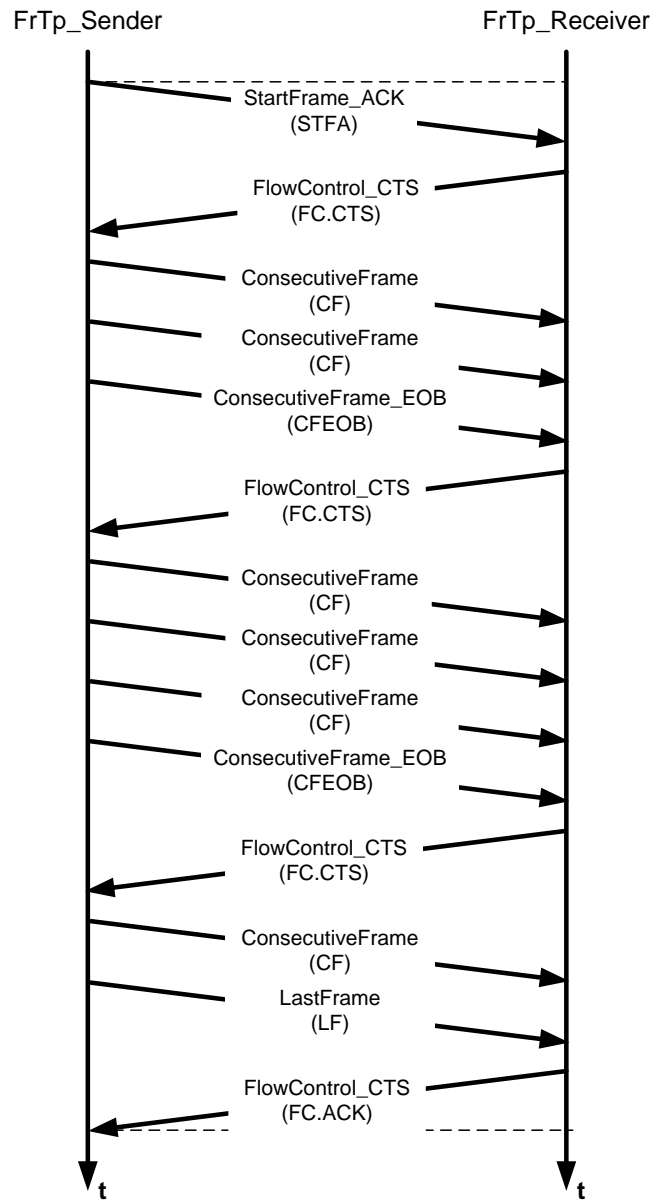

**Figure 10: Frame sequence of a segmented acknowledged data transfer with unknown message length  $J()$**

### 7.2.3 Limitation to ISO10681-2

The limitations to ISO 10681-2 are described in chapter 4.3 - Table 1.



### 7.3 Internal Module behavior specification

This chapter specifies the internal behaviour of the FlexRay Transport Layer module to fulfill the protocol behaviour according to ISO 10681-2 [16].

#### 7.3.1 Overview

Figure 11 depicts an abstract overview of the FrTp layer module architecture.

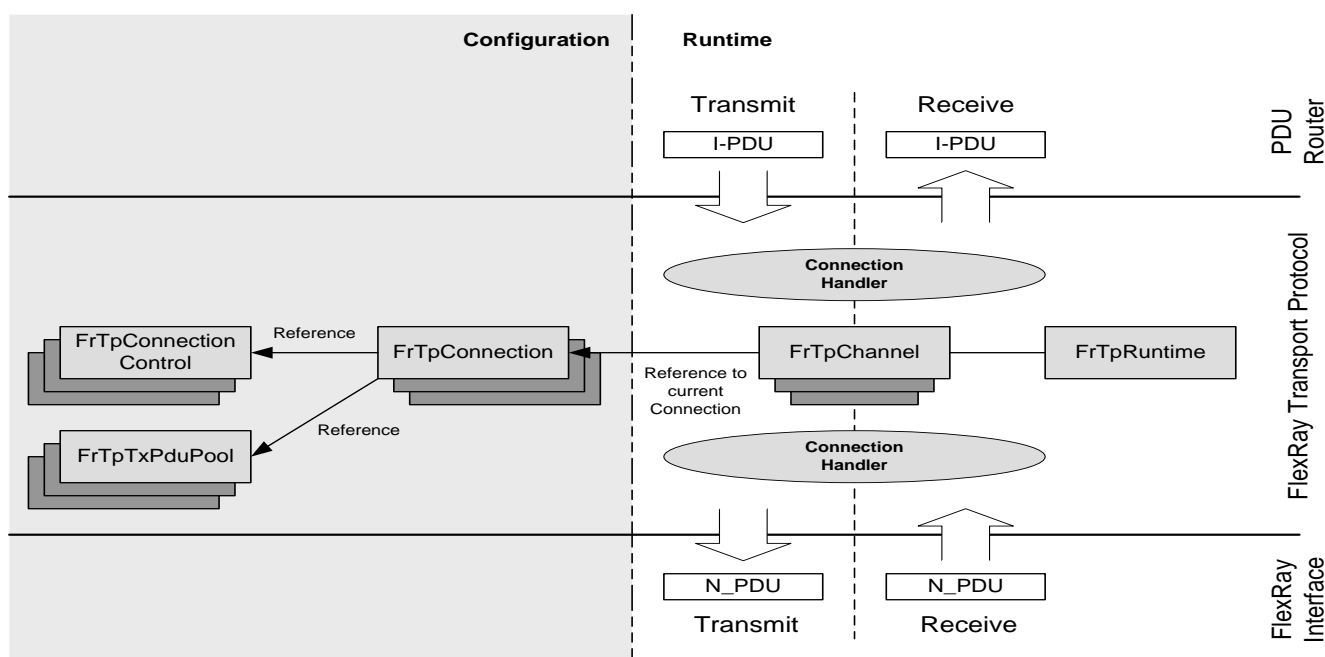

Figure 11: FlexRay Transport Module overview

Figure 11 depicts a division between configuration parts and runtime parts. After the module is initialized it is able to transmit I-PDUs from an upper layer (PDUR) or receive N-PDUs from a lower layer (FrIf). Below there is a short describes of the different parts being involved in FrTp layer handling procedure.

Term	Description
FrTpConnection	A connection is a configuration parameter set which includes all parameters to identify a connection link between different communication nodes uniquely. A connection has a fixed assignment between a sender node (representing by a source address), one or more receiver node(s) (representing by a target address), the upper Layer I-PDU source (representing by an I-PDU-ID). Additionally a connection has a reference to a set of N-PDUs (PDU-Pool) which are defined for sending data via FrTp. A reference to connection specific parameters (e.g. timings and timeouts etc.) is defined too.

FrTpConnection Control	A connection configuration is a parameter set which includes configuration specific parameter (e.g. timings, timeouts, default parameters etc.). It is referenced by a connection.
FrTpTxPduPool	A Tx-N-PduPool is a set of N-PDUs which are defined for FrTp sending purpose.
FrTpChannel	A channel is a runtime resource of the FrTp module which implements all communication control mechanisms (e.g. state machine etc.) to handle a communication link via FlexRay. A channel could be allocated by the connection handler to process a required connection. Therefore a channel has a reference to the connection which is currently handled by this channel. If a data transfer has been finished the assignment between the channel and the connection is cleared and the channel could be reallocated by another connection.
FrTpRuntime	FrTpRuntime is a set of runtime parameters which is necessary to control active connections. (please refer to chapter 7.3.3.1)
Connection Handler	The connection handler is an abstract part of the FrTp module and is responsible for the (re-)allocation of channels and the (re-)assignment of channels and connections.

If an upper layer module (e.g. COM, DCM etc) wants to transmit data (I-PDU) the PduR module executes the corresponding FrTp layer module API call. The connection handler evaluates the I-PDU-ID (equal to N-SDU-ID from FrTp's point of view) for the corresponding connection. The connection handler allocates a free channel and set channel's connection reference to the selected connection. The channel could now initialize with the connection control parameter set which is access able via the references. The channel process the communication until all data have been transmitted. After the last N-PDU was send the connection handler will free the channel and also the reference to the connection is reset.

If an N-PDU is received via FlexRay the FrIf executes the corresponding FrTp API call. The connection handler evaluates the target address and the source address of the N-PDU which is part of the Protocol Control Information (PCI). The connection handler search for the corresponding connection, allocates a channel, set the reference to the selected connection and initialize them. Until the last N-PDU was received the connection handler reallocates the channel, skips the reference to the selected connection and delivers the I-PDU to the addressed upper layer by calling the corresponding PDUR-module API.

### 7.3.2 Configuration data

### 7.3.2.1 FrTpConnection

A connection identifies the sender and the receiver(s) of this particular communication link.

An FrTp connection link is defined by

- a) a target address of the receiver node(s) and
- b) a source address of the sender node.

For the internal handling of different PDUs across the FlexRay communication stack the I-PDU-ID (N-SDU-ID) identifies the data link to upper layer's sender or receiver modules (see Figure 2).

Additionally a connection has a reference to a set of N-PDUs (`FrTpTxPduPool`) which are defined for sending data via this particular connection. A reference to connection specific parameters, e.g. timings and timeouts etc is defined too (`FrTpConnectionConfig`).

**[SWS\_FrTp\_01013]**      「An `FrTpConnection` container shall implement all parameters as defined in chapter 10.2.」()

**[SWS\_FrTp\_01014]**      「For each connection link the FrTp module shall handle, a new instance of `FrTpConnection` container shall be created.」()

**[SWS\_FrTp\_01015]**      「The FrTp module shall support a post build time configurable number of connections<sup>3</sup>.」()

**[SWS\_FrTp\_01017]**      「Each `FrTpConnection` shall have a module wide unique `RemoteAddress / LocalAddress` pair (see section 10.2).<sup>4</sup>」()

**[SWS\_FrTp\_01018]** 「 Each `FrTpConnection` shall have a module wide unique `FRTP_SDUID (N-SDU ID)` (see section 10.2).」(`SRS_Fr_05077`)

### 7.3.2.2 FrTpTxPduPool

The `FrTpTxPduPool` contains a list of N-PDUs configured for sending FrTp N-PDUs. An `FrTpTxPduPool` could be referenced by different `FrTpConnections` but each `FrTpConnection` has exactly one reference to one `FrTpTxPduPool`. (see

<sup>3</sup> Post-build time configurable number of connections is required e.g. for gateways. If new connections are defined during vehicle lifecycle only the connection's parameter set has to be updated.

<sup>4</sup> The AUTOSAR local address and remote address is mapped to the ISO 10681-2 source address and target address.

also Figure 17). The `FrTpTxPduPools` are necessary to support dynamic bandwidth assignment for connections.

Chapter 7.5.5 describes the dynamic bandwidth assignment in detail. At this position in specification only the term `FrTpTxPduPool` shall be introduced and some basic requirements to `FrTpTxPduPools` are specified.

**[SWS\_FrTp\_01019]**  $\Gamma$  An `FrTpTxPduPool` container shall implement all parameters as defined in chapter 10.2.9.]()

**[SWS\_FrTp\_01020]**  $\Gamma$ A single `FrTpTxPduPool` can be referenced by different `FrTpConnections`.]()

Note: Configuration of PDU Pools to limit bandwidth to an ECU is described in chapter 10.4.4.

### 7.3.2.3 FrTpConnectionControl

An `FrTpConnectionControl` container contains all static (not runtime) parameters, which are necessary to control a connection e.g. initial timer values, timeout control values etc. Each `FrTpConnection` has an exclusive link to an `FrTpConnectionControl` container. `FrTpConnections` with equal control parameters can reference the same `FrTpConnectionControl`<sup>5</sup>.

**[SWS\_FrTp\_01021]**  $\Gamma$  An `FrTpConnectionControl` Container shall implement all parameters as defined in chapter 10.2.]()

**[SWS\_FrTp\_01022]**  $\Gamma$ An `FrTpConnectionControl` container can be referenced by different `FrTpConnections`.]()

### 7.3.3 Runtime data

As depict in Figure 11 also some runtime information are required. All runtime information are encapsulated in containers. This chapter defines all the runtime containers with the corresponding variables in that scope as it necessary to understand FrTp's work.

It's recommended to place all runtime data required for implementation into the global `FrTpRuntime` container too.

---

<sup>5</sup> Use case: Reducing configuration control container instances

### 7.3.3.1 FrTpRuntime

<b>Module Name</b>	<b>FrTpRuntime</b>
<b>Module Description</b>	This container contains the runtime parameters / variables which are necessary to handle FlexRay Transport Protocol communication according to ISO 10681-2.

Included Containers		
Container Name	Multiplicity	Scope / Dependency
FrTp_Channel	1..*	FrTp Channel: This container contains the runtime parameters / variables for an FrTpChannel.
FrTp_ConCtrlRuntime	1..*	FrTp Connection Control Runtime: This container contains the runtime parameters / variables to handle an FrTpConnection.
FrTp_PduPoolRuntime	1..*	FrTp Pdu Pool Runtime: This container contains the runtime parameters / variables to handle an FrTpPduPool.

### 7.3.3.2 FrTpChannel

As described above a channel is a runtime resource of the FrTp. A channel could be allocated to handle a connection. This chapter describes the relevant information of a channel without implementation specific information (e.g. types etc).

<b>Name</b>	<b>FrTpChannel</b>
<b>Description</b>	This container contains the parameters and variables of a FlexRay channel
Container parameters and variables	

Information	Description
FrTpChannelNumber	Number of that channel
FrTpTxChannelState	Current state of the Tx channel (idle = 0 or busy = 1)
FrTpTxConState	FrTp Tx Connection State: This parameter implements the current state of the Tx connection (Tx communication state machine according to ISO 10681-2 protocol handling).
FrTpTxConRef	FrTp Tx Connection Reference: This is the reference (pointer to connection) to the current Tx <i>FrTpConnection</i> , the channel is currently processing.
FrTpTxConTxPduPendingCounter	FrTp Tx Connection Tx Pdu Pending Counter: This counter counts the number of currently transmitted but not confirmed Fr N-PDUs of the active TxConnection (e.g. SF, CF, LF) This counter shall be incremented each time an FrTp Tx N-PDU is send by the FrTp.

	This counter shall be decremented each time an transmitted FrTp Tx N-PDU is confirmed by the FrIf.
FrTpTxConTxPduPoolRuntimeRef	FrTp TxConnection Tx PDU Pool Runtime Reference: This is the reference (pointer to FrTp_TxPduPoolRuntime) to the runtime container of the corresponding PDU-Pool. Note: The runtime container of the PDU Pool controls the TxConfirmation signals.
FrTpTxConConfigRuntimeRef	FrTp Tx Connection Configuration Runtime Reference: This is the reference (pointer to FrTp_ConConfigRuntime) to the runtime container of the corresponding Tx connection configuration. Note: The runtime container of the Tx connection configuration controls the connection parameters, which are changeable during runtime.
FrTpRxChannelState	Current state of the Rx channel (idle or busy)
FrTpRxConState	FrTp Rx Connection State: This parameter implements the current state of the Rx connection (Rx communication state machine according to ISO 10681-2 protocol handling).
FrTpRxConRef	FrTp Rx Connection Reference: This is the reference (pointer to connection) to the current Rx <i>FrTpConnection</i> , the channel is currently processing.
FrTpRxConTxPduPendingCounter	FrTp Rx Connection Tx Pdu Pending Counter: This counter counts the number of currently transmitted but not confirmed Fr N-PDUs of the active RxConnection (FlowControl). This counter shall be incremented each time an FrTp Tx N-PDU is send by the FrTp. This counter shall be decremented each time a transmitted FrTp Tx N-PDU is confirmed by the FrIf. Therefore that FrTp Rx Connection Tx Pdu Pending Counter toggles only between 0 and 1.
FrTpRxConTxPduPoolRuntimeRef	FrTp Rx Connection Tx PDU Pool Runtime Reference: This is the reference (pointer to FrTpTxPduPoolRuntime) to the runtime container of the corresponding PDU-Pool. Note: The runtime container of the PDU Pool controls the TxConfirmation signals. This reference is required for the transmission control of FlowControl N-PDU during an

	ongoing reception on that channel.  Note: For a full duplex channel configuration (see chapter 7.3.3.2.1) the <code>FrTpTxConTxPduPoolRuntimeRef</code> and the <code>FrTpRxConTxPduPoolRuntimeRef</code> are equal.
<code>FrTpRxConConfigRuntimeRef</code>	<code>FrTp Rx Connection Configuration Runtime Reference:</code> This is the reference (pointer to <code>FrTpConConfigRuntime</code> ) to the runtime container of the corresponding Rx connection configuration. Note: The runtime container of the Rx connection configuration controls the connection parameters, which are changeable during runtime.
No included containers	

**[SWS\_FrTp\_00228]** ⌈ The FrTp module shall support concurrently work of multiple `FrTpChannels`<sup>6</sup>.⌋()

**[SWS\_FrTp\_00088]** ⌈ The exact number of provided channels shall be configurable by the parameter `FrTpChanNum` (see section 10.2).⌋()

**[SWS\_FrTp\_01025]** ⌈ The runtime variable `FrTpRxChannelState` shall be switched from “idle” state to “busy” state if the channel is allocated for an Rx connection.⌋()

**[SWS\_FrTp\_01026]** ⌈ The runtime variable `FrTpRxChannelState` shall be switched from “busy” state to “idle” state if the channel is free after an Rx connection is closed.⌋()

**[SWS\_FrTp\_01117]** ⌈ The runtime variable `FrTpTxChannelState` shall be switched from “idle” state to “busy” state if the channel is allocated for an Tx connection.⌋()

<sup>6</sup> The number of channels represents the number of connections, which could be handled concurrently for the same direction. Therefore it is an indication of the performance of the FrTp. On the other hand a Gateway requires more channels than normal ECUs because a gateway handles more concurrent connections. Hence the number of supported channels shall be configurable.

[SWS\_FrTp\_01118] The runtime variable *FrTpTxChannelState* shall be switched from “busy” state to “idle” state if the channel is free after an Tx connection is closed. ]()

**Note:** The error handling for the case if no FrTpChannel resource is available (*FrTpTxChannelState* ≠ idle) for data transmission is specified in [SWS\_FrTp\_01041.

### 7.3.3.2.1 Full Duplex and Half Duplex

Normally a Full Duplex channel supports concurrent transmission and reception of Fr N-PDUs at the same time for the same<sup>7</sup> connection. Figure 12 depicts a Full Duplex implementation.

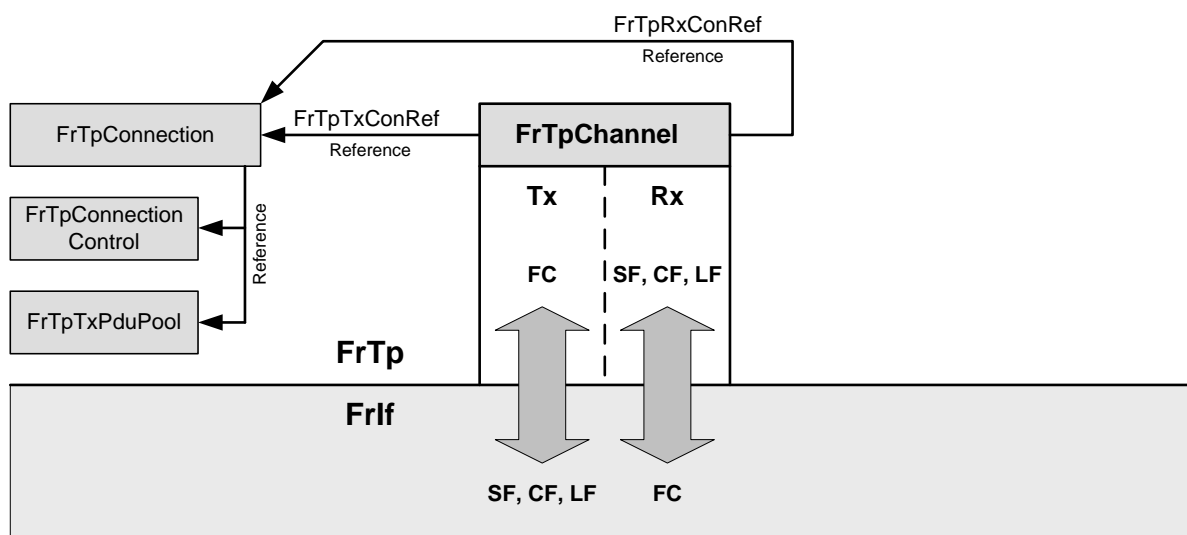

Figure 12: Full Duplex Overview

On the other hand a Half Duplex channel supports only a data transfer for one direction. The fact that an Rx transmission has also to send a FlowControl or a Tx transmission has to receive a FlowControl is not similar to a full duplex connection. Figure 13 depicts a half duplex FrTp\_Channel, where either a Tx or a Rx Connection is processed.

<sup>7</sup> Theoretically it is possible that two ECUs transferring data to each other at the same time. That means that each ECU is sender and receiver concurrently. If both ECUs have only one Remote Address and one Local Address the FrTp shall evaluate the PCI to distinguish whether a PDU for Rx-Direction (CF or LF) or a PDU for Tx-direction (FC) was received. This is a full duplex mechanism.



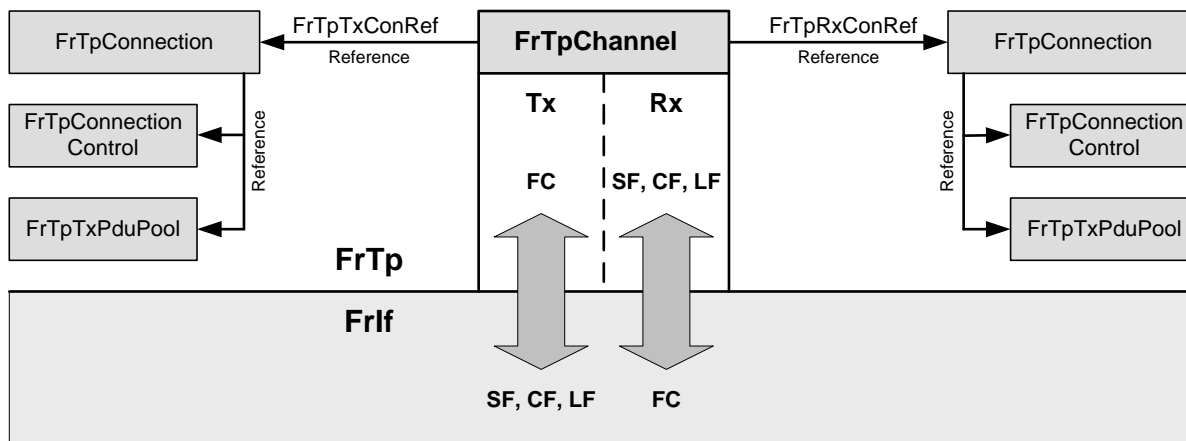

Figure 13: Half Duplex Overview

The final functionality of FrTpChannels depends on implementation and therefore it is not specified in this document.

### 7.3.3.3 FrTpConnectionControlRuntime

This chapter describes the relevant information of Connection Control without implementation specific information (e.g. types etc).

Name	FrTpConCtrlRuntime
Description	FrTp Connection Control Runtime: This container contains the ConnectionControl runtime data.
Container parameters and variables	

Information	Description
FrTpSCexpRuntime	FRTP_SEPARATION_CYCLE_EXPONENT Runtime value of FrTpSCexp parameter. This parameter could be changed via API-Call "FrTp_ChangeParameter" and differs than from the configured default value.
FrTpMaxNbrOfNPduPerCycleRuntime	FRTP_MAX_NUMBER_OF_NPDU_PER_CYCLE Runtime value of FrTpMaxNbrOfNPduPerCycle parameter. This parameter could be changed via API-Call "FrTp_ChangeParameter" and differs than from the configured default value.
No included containers	

## 7.4 Initialization and shutdown

[SWS\_FrTp\_01028] 「 The FrTp module shall have two internal states, FRTP\_OFF and FRTP\_ON.」()

- [SWS\_FrTp\_01029]**     The FrTp module shall implement a static status variable *FrTpState* to denote whether the FrTp module is initialized or not<sup>8</sup>.]()
- [SWS\_FrTp\_01106]**     The *FrTpState* shall be checked to detect whether FrTp module is initialized or not.]()
- [SWS\_FrTp\_01030]**     The FrTp module shall be in the `FRTP_OFF` state after power up.]()
- [SWS\_FrTp\_01032]**     The FrTp module shall change to the internal state `FRTP_ON` when the FrTp has been successfully initialized by the service primitive *FrTp\_Init()*.]()
- [SWS\_FrTp\_01033]**     The FrTp module shall performed normal FrTp operation tasks (e.g. segmentation, reassembly etc.) only when the FrTp module is in the `FRTP_ON` state<sup>9</sup>.]()
- [SWS\_FrTp\_01034]**     The service primitive *FrTp\_Init* shall initialize all global variables of the module and sets all transport protocol connections in a sub-state of `FRTP_ON`, in which neither transmissions nor receptions are in progress. ](SRS\_Fr\_05088)
- [SWS\_FrTp\_01035]**     If the FrTp module is in the global state `FRTP_ON`, a call of the service primitive *FrTp\_Init* shall return the module to an uncritical idle state (idle state = `FRTP_ON`, but neither transmission nor reception are in progress) and the module shall loose all current connections. ](SRS\_Fr\_05088)
- [SWS\_FrTp\_01036]**     The FrTp module shall change to the internal state `FRTP_OFF` when the service primitive *FrTp\_Shutdown()* has been executed successfully.]()

---

<sup>8</sup> This variable is used for development error detection.

<sup>9</sup> This requires that *FrTp\_Init()* is called before the normal FrTp functionality is used by the COM-Stack.

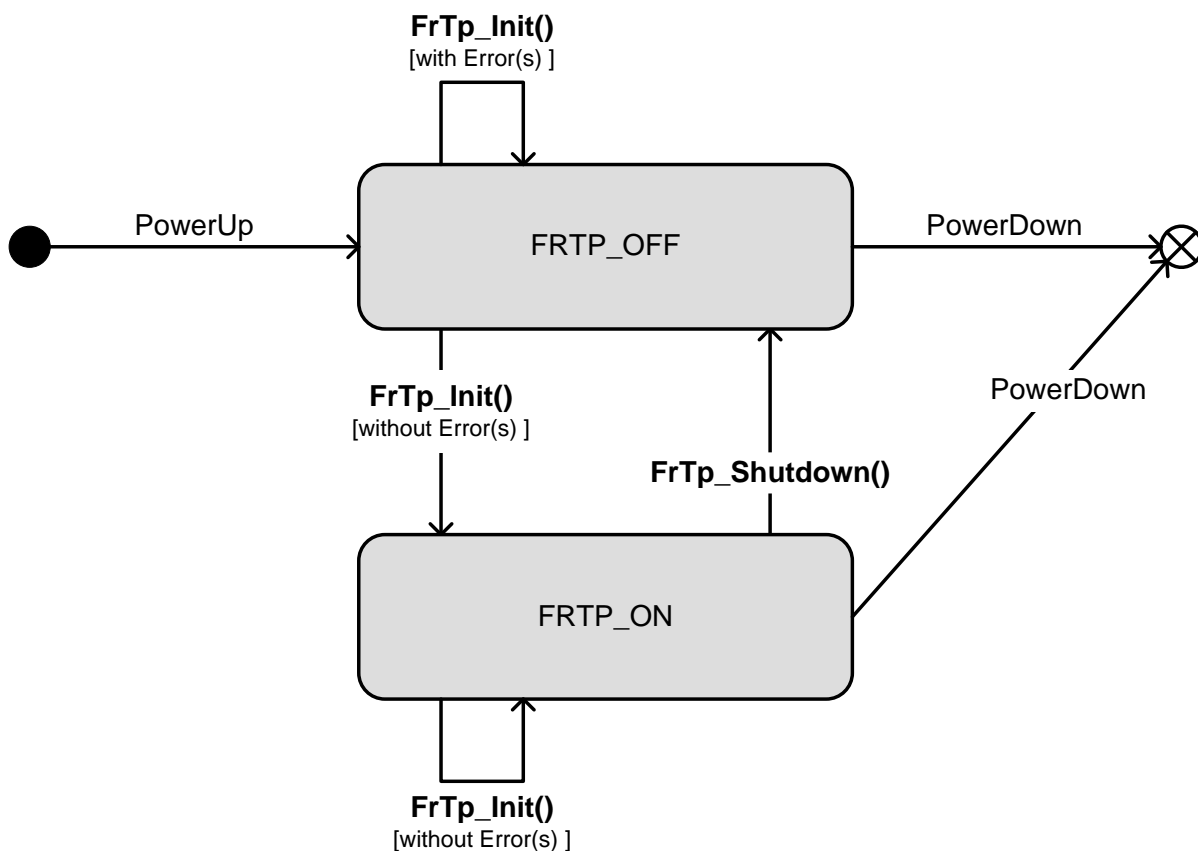

Diagram 1: FrTp Initialization and shutdown state diagram

## 7.5 Data Transfer Processing

This chapter covers all topics of FrTp module data transfer processing if transmission of data (Fr N-SDU) is requested by an upper layer (e.g. COM, DCM etc.) via PduR module or if data (Fr N-PDUs) have been received via FrIf module. For a better understanding the different topics are encapsulated in several sub-clauses starting with the basic definition of data transfer and reception. Buffer handling is described within an additional chapter.

The FlexRay protocol stack supports two different buffer access modes for data transmission:

- a) Immediate Buffer Access Mode
- b) Decoupled Buffer Access Mode

Due to this fact there are two different sequences for data transfer processing.

### 7.5.1 Flags

The FrTp module uses several flags to signal internal states. (see also sequence diagrams in Chapter 9). This chapter describes the flags required for inter-module state handling.

### 7.5.1.1 TX\_SDU\_AVAILABLE

The `TX_SDU_AVAILABLE` flag is set by the service primitive *FrTp\_Transmit* to indicate the N-SDU transmit request.

**[SWS\_FrTp\_00415]**      「The `TX_SDU_AVAILABLE` flag shall exist for every channel.」()

**[SWS\_FrTp\_00416]**      「The `TX_SDU_AVAILABLE` flag shall indicate an Fr N-SDU transmit request for a configured connection on an allocated channel.」()

**Note:**                For detailed information about set and reset conditions and behaviour please refer to chapter 7.5.2 and **[SWS\_FrTp\_01057]**.

### 7.5.1.2 TX\_SDU\_UNKNOWN\_MSG\_LENGTH

The `TX_SDU_UNKNOWN_MSG_LENGTH` flag is set by the service primitive *FrTp\_Transmit* to indicate the N-SDU transmit request with an unknown message length. Depending on the status of that flag the FrTp module will recall the service primitive *PduR\_FrTpCopyTxData* several times until all data are transmitted.

**[SWS\_FrTp\_01101]**      「The `TX_SDU_UNKNOWN_MSG_LENGTH` flag shall indicate an Fr N-SDU transmit request with unknown message length.」()

**[SWS\_FrTp\_01102]**      「The `TX_SDU_UNKNOWN_MSG_LENGTH` flag shall exist for every channel.」()

**Note:**                For detailed information about set and reset conditions and behaviour please refer to chapter 7.5.2 and **[SWS\_FrTp\_01124]**.

### 7.5.1.3 RX\_PDU\_AVAILABLE

The `RX_PDU_AVAILABLE` flag is set by the service primitive *FrTp\_RxIndication* to indicate the reception of an N-PDU.

**[SWS\_FrTp\_00418]**      「The `RX_PDU_AVAILABLE` flag shall exist for every Fr N-PDU, which is configured to be received by the FrTp module.」()

**Note:**                For detailed information about set and reset conditions and behaviour please refer to chapter 7.5.3 and **[SWS\_FrTp\_01074]**.

#### 7.5.1.4 RX\_ERROR

The RX\_ERROR<sup>10</sup> flag is required in case transmission with acknowledgement and retry is configured. During a segmented data reception an error could occur but sending FlowControl is currently not possible. In that case the information about an error has to be stored until sending a FlowControl is allowed.

**[SWS\_FrTp\_00428]**     ┌The RX\_ERROR flag shall exist for every FrTpChannel.  
                        └()

**[SWS\_FrTp\_00429]**     ┌The RX\_ERROR flag shall indicate that an error occurred  
                        during a segmented reception.└()

**[SWS\_FrTp\_00430]**     ┌The RX\_ERROR flag shall be cleared after the reaction  
                        (Retry, Negative Acknowledgement, abortion).└()

### 7.5.2 Transmit Data

**[SWS\_FrTp\_01204]**   ┌During transmission, the FrTp shall use addressing  
information provided by the upper layer via the meta data items  
SOURCE\_ADDRESS\_16 and TARGET\_ADDRESS\_16 as local address and remote  
address of the transmitted N-PDUs and to identify received flow control N-PDUs.└()

**[SWS\_FrTp\_01205]**   ┌ If FrTpLa and/or FrTpRa are configured for a transmitted N-  
SDU, they are used even when the addressing information is the provided by the  
upper layer. If not, the address information in the N-PDUs shall be set according to  
the provided address information.└()

#### 7.5.2.1 Transmit Data via 'Immediate Buffer Access' Mode

This chapter defines a data transfer requested by an upper layer (e.g. COM, DCM etc.) via 'Immediate Buffer Access' Mode.

---

<sup>10</sup> Refer ISO 10681-2 – chapter 7.5.7.2.3.

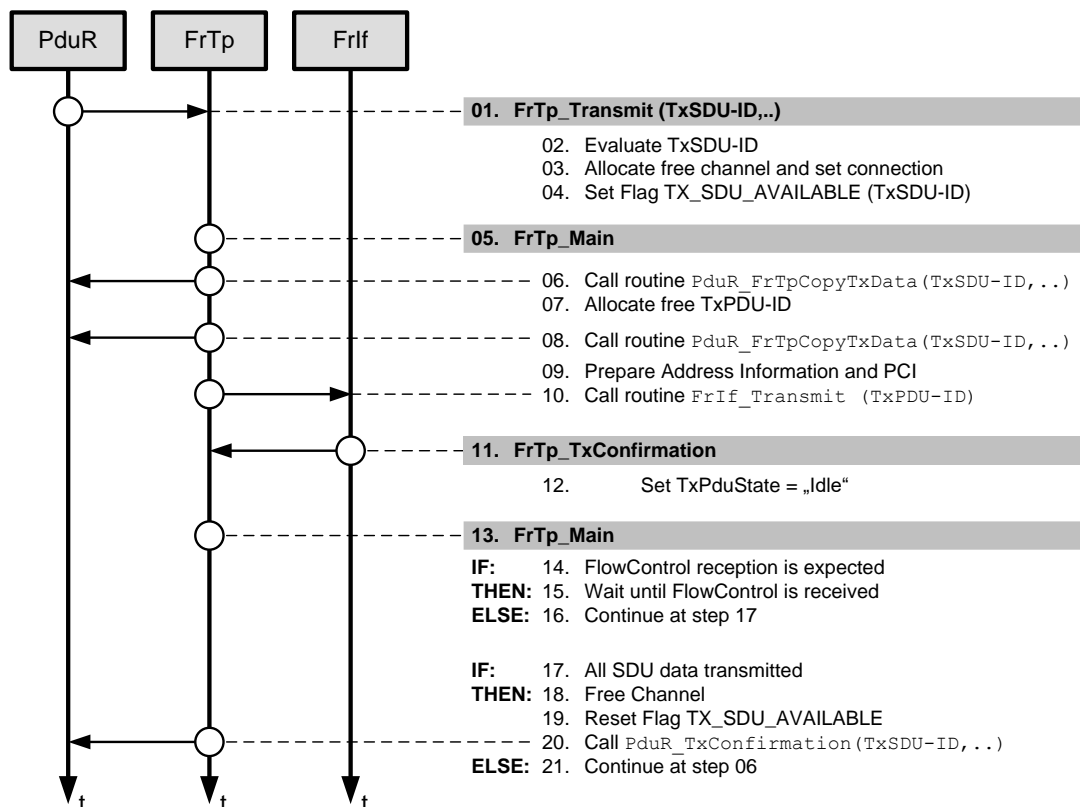

Figure 14: Transmit data overview in ‘Immediate Buffer Access’ mode

Figure 14 depicts the internal processing for data transmission in principle<sup>11</sup> if “Immediate Buffer Access” mode is configured<sup>12</sup>. Below there is a description of the different steps which are necessary to transmit data via FrTp.

### Step 1 - 4

**[SWS\_FrTp\_00136]**     ⌈ Sending Fr N-SDU data shall always be initiated by the service primitive call of `FrTp_Transmit` (see chapter 8.3.3.1). ⌋()

**[SWS\_FrTp\_01043]**     ⌈ The FrTp module shall evaluate the value of `PduInfoType.SduLength`:

**SduLength = 0:**     Transmission with unknown message length is requested

**SduLength ≠ 0:**     Transmission with known message length is requested. ⌋()

**[SWS\_FrTp\_01044]**     ⌈ If support unknown message length is configured the FrTp module shall set the flag `TX_SDU_UNKNOWN_MSG_LENGTH`

<sup>11</sup> Figure 14 depicts only the overview of data transmission for a single channel without further functionality (e.g. transmit cancellation) or internal behaviour (e.g. internal control data handling, return values etc.). Also a schedule for data transfer in concurrent channels is not described here.

<sup>12</sup> Buffer access mode is configured for each N-PDU and is referenced via the PDU-Pool.

according to the result of **[SWS\_FrTp\_01043]** (see also chapter 7.5.1.2).<sub>J</sub>()

**[SWS\_FrTp\_01134]**    ┌ The FRTP module shall raise an development error FRTP\_E\_UMSG\_LENGTH\_ERROR when

1.       a transmission with unknown message length is detected and
2.       support of unknown message length is not configured and
3.       development error detection is enabled for the FrTp module.<sub>J</sub>()

The service primitive parameter TxPduld shall be used to select the correct connection. This shall be done by searching for the correct entry within the FrTpConnection container (FrTpConnection.FrTpTxSduId). If a valid parameter TxPduld is given, the FrTp module shall search for a free channel resource (FrTpTxChannelState = Idle) and allocate them to control the requested Tx data transfer.

**[SWS\_FrTp\_01038]**    ┌ An ongoing data transfer shall be signalled by the flag TX\_SDU\_AVAILABLE (see also chapter 7.5.1.1).<sub>J</sub>()

**[SWS\_FrTp\_01039]**    ┌ The service primitive shall set the flag TX\_SDU\_AVAILABLE only, if

- a) the requested TxPduld is valid
- b) a free channel resource is available (FrTpTxChannelState = Idle)<sub>J</sub>()

**[SWS\_FrTp\_01040]**    ┌ If the current parameter TxPduld is not supported the service primitive FrTp\_Transmit

- a) shall be terminated and the return value shall be set to E\_NOT\_OK (see also chapter 8.2.1) and
- b) the FrTp module shall raise an development error FRTP\_E\_INVALID\_PDU\_SDU\_ID when development error detection for the FrTp module is enabled.<sub>J</sub>()

**[SWS\_FrTp\_01041]**    ┌ If no free channel is available (FrTpTxChannelState ≠ Idle) the service primitive FrTp\_Transmit shall be terminated and the return value shall be set to E\_NOT\_OK (see also chapter 8.2.1)<sup>13</sup>.<sub>J</sub>()

**[SWS\_FrTp\_01185]**    ┌ The FrTp module shall raise a runtime error FRTP\_E\_NO\_CHANNEL.<sub>J</sub>()

<sup>13</sup> This scenario could occur on gateways, if communication via more connections is requested than channels resources are configured.

**[SWS\_FrTp\_01200]**     ┌ If the request for a message transmission has not been accepted due to another transmission for the specified address information is active; then `FrTp_Transmit` shall return `E_NOT_OK`.┐()

### Step 5 - 10

If the `TX_SDU_AVAILABLE` flag is set, the `FrTp` module has to evaluate the length of the currently available `FrTp` N-SDU data by calling the service primitive `PduR_FrTpCopyTxData()`<sup>14</sup> a first time. With knowledge of the available data size `FrTp` module scans the `FrTpTxPduPool` and allocates the first free `FrTpPdu` for that data transfer. Depending on the available `FrTp`-N-SDU length and the `FrTpTxPduPool`'s free `FrTpPdu` length the `FrTp` module decides whether segmentation is necessary or not for that N-SDU transfer. By calling the service primitive `PduR_FrTpCopyTxData()` the data shall be copied to the corresponding buffer. In a next step the corresponding Address Information and PCI are prepared and the service primitive `FrIf_Transmit` is called with the corresponding `TxDuld`.

**[SWS\_FrTp\_01042]**     ┌ If the `TX_SDU_AVAILABLE` flag is set, the `FrTp` module shall call the service primitive `PduR_FrTpCopyTxData()` to get the currently available `FrTp` N-SDU Length information.┐()

**[SWS\_FrTp\_01045]**     ┌ The `FrTp` module shall always allocate the first free `FrTpTxPdu` while scanning the corresponding `FrTpTxPduPool` (see also chapter 7.3.2.2).┐()

**[SWS\_FrTp\_01046]**     ┌ If a free `FrTpTxPdu` is identified, the `FrTp` module shall use this `FrTpTxPdu` to continue current transmission process.┐()

**[SWS\_FrTp\_01047]**     ┌ If no free `FrTpTxPdu` is identified, the `FrTp` module shall postpone processing for the corresponding connection till the next main function call.┐()

Note:                 `FrTp` module shall postpone the processing for the corresponding connection until either free `FrTpTxPdu` is identified according to `SWS_FrTp_01046` or a timeout occurs (see section 7.5.8).

---

<sup>14</sup> The available data length evaluation depends on different scenarios the `FrTp` is used in.

- In case of a normal ECU which transfers data with unknown message lengths it is necessary to evaluate the length of the currently stored `FrTp`-N-SDU.
- In case an ECU transmits data with known message length the Tx data length is given by the parameter of the `FrTp_Transmit` service primitive. An additional evaluation by calling `PduR_FrTpCopyTxData(..)` is possible to have equal evaluation sequences for known and unknown message length transfers but could be skipped by runtime optimisation (implementation dependency).
- In case of a Gateway which routes N-SDUs of different bus systems it is necessary to get the currently available (received) data length in the gateway buffer.



**[SWS\_FrTp\_01048]** 「The FrTp module shall decide whether segmentation for the requested N-SDU transfer is required or not depending on the length information of the first allocated FrTpTxPdu from an FrTpTxPduPool for the currently processed FrTpConnection (see also Diagram 2). 」()

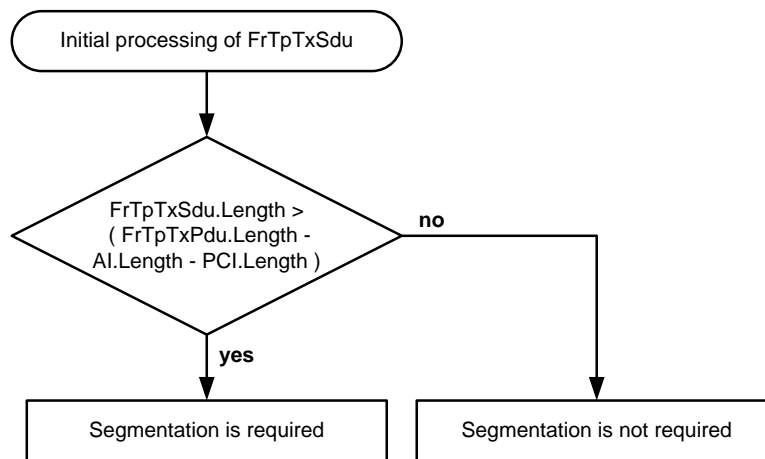

Diagram 2: Segmentation decision

Note: The decision whether segmentation is possible or not depends also on the connection mode (1:1 or 1:n).

**[SWS\_FrTp\_01123]** 「The FrTp module shall call the service primitive PduR\_FrTpCopyTxData() to copy the currently available FrTp N-SDU data with a length of FrTpTxPdu length to the corresponding transmit buffer.」()

**[SWS\_FrTp\_01049]** 「The FrTp module shall prepare the Address Information and PCI according to the result of [SWS\_FrTp\_01048] as defined in specification ISO 10681-2 [16].」()

**[SWS\_FrTp\_01050]** 「The FrTp module shall initiate an N-PDU data transfer by calling the service primitive FrIf\_Transmit() with the TxPduId of the recently allocated FrTpTxPdu.」()

**[SWS\_FrTp\_01051]** 「The FrTp shall set the corresponding data length referenced by the service primitive FrIf\_Transmit's parameter PduInfoType to the exact data length of the buffer<sup>15</sup>.」()

<sup>15</sup> FrTp transmits always the real amount of data stored in the corresponding buffer. FrTp is not responsible for fill bytes. Fill up N-SDUs to a configured frame size is done within lower layers (e.g. FrIf or FlexRay Driver). The FrTp only decides whether segmentation is necessary or not and to

**Step 11 - 12**

If the N-PDU was successfully transmitted by the FrIf module, the FrIf module shall call the service primitive `FrTp_TxConfirmation` with result `E_OK`. Within this service primitive the FrTp module shall reset the state of the corresponding `FrTpTxPdu`.

**[SWS\_FrTp\_01052]**      「The service primitive `FrTp_TxConfirmation` shall be called by the underlying layer module after a successful or failed transmission of the corresponding N-PDU.」()

**[SWS\_FrTp\_01053]**      「The service primitive `FrTp_TxConfirmation` shall be called by the underlying layer module with the corresponding `FrTpTxConfirmationPduId` of the successful transmitted PDU.」()

**[SWS\_FrTp\_01054]**      「The service primitive `FrTp_TxConfirmation` shall reset the state of the corresponding `FrTpTxPdu` (N-PDU) to “idle”.」()

**Step 13 - 16**

Depending on ISO-10681-2 protocol handling in some cases a response N-PDU (Flow Control) from the receiver is expected by the sender. Hence the sender has to wait until the response N-PDU (Flow Control) is received and continue processing after reception.

**[SWS\_FrTp\_01055]**      「The FrTp module shall implement a timing and timeout behaviour as defined in chapter 7.5.8」()

**Step 17 - 21**

If all N-SDU data are transmitted the FrTp module shall free all allocated resources and reset all flags which signals an ongoing data transfer for this connection. If the data transmission is pending, the FrTp module shall continue the data transfer at step 6.

**[SWS\_FrTp\_01056]**      「The FrTp module shall free the allocated channel (`FrTpTxChannelState = Idle`) if

- a) all Tx N-SDU data are transmitted and
- b) `FrTp_TxConfirmation` was given with result `E_OK` and
- c) the final acknowledge is received in case acknowledge is configured.

---

segment N-PDU Consecutive Frames to the maximum length of the corresponding PDU of the PduPool.

Or

d) FrTp\_TxConfirmation was given with result E\_NOT\_OK.

]()

**[SWS\_FrTp\_01057]**    ┌ The FrTp module shall reset the flag  
TX\_SDU\_AVAILABLE, if:

a) all N-SDU data are transmitted and

b) FrTp\_TxConfirmation was given with result E\_OK and

c) the final acknowledge is received in case acknowledge is configured.

Or

d) FrTp\_TxConfirmation was given with result E\_NOT\_OK.

]()

**[SWS\_FrTp\_01124]**    ┌ The FrTp module shall reset the flag  
TX\_SDU\_UNKNOWN\_MSG\_LENGTH, if:

a) all N-SDU data are transmitted and

b) FrTp\_TxConfirmation was given with result E\_OK and

c) the final acknowledge is received in case acknowledge is configured  
or

d) if transmission was aborted or FrTp\_TxConfirmation was given with  
result E\_NOT\_OK.]()

**[SWS\_FrTp\_01058]**    ┌The FrTp module shall always call the service primitive  
PduR\_FrTpTxConfirmation for the corresponding FrTpTxSdu ID  
after the transmission request was accepted.

The result shall be E\_OK if

a) all N-SDU data are transmitted and

b) FrTp\_TxConfirmation was given with result E\_OK and

c) the final acknowledge is received in case acknowledge is configured.

Otherwise the result shall be E\_NOT\_OK.

]()

**[SWS\_FrTp\_01198]**    ┌ If an FC frame is received with an invalid FS or with FS  
set to OVFLW or ABT, the FrTp module shall abort the transmission of  
this message and notify the upper layer by calling the callback function  
PduR\_FrTpTxConfirmation with the result E\_NOT\_OK.]()

**[SWS\_FrTp\_01199]**    ┌ If an FC frame is received with the FS set to ACK\_RET,  
where the BP points to a position outside the buffer of the sender, then  
the FrTp module shall abort the transmission of this message and notify  
the upper layer by calling the callback function  
PduR\_FrTpTxConfirmation with the result E\_NOT\_OK.]()

### 7.5.2.2 Transmit Data via ‘Decoupled Buffer Access’ Mode

Figure 15 depicts the internal processing for data transmission in principle<sup>16</sup> if “Decoupled Buffer Access” mode is configured<sup>17</sup>. Below there is a description of the different steps which are necessary to transmit data via FrTp.

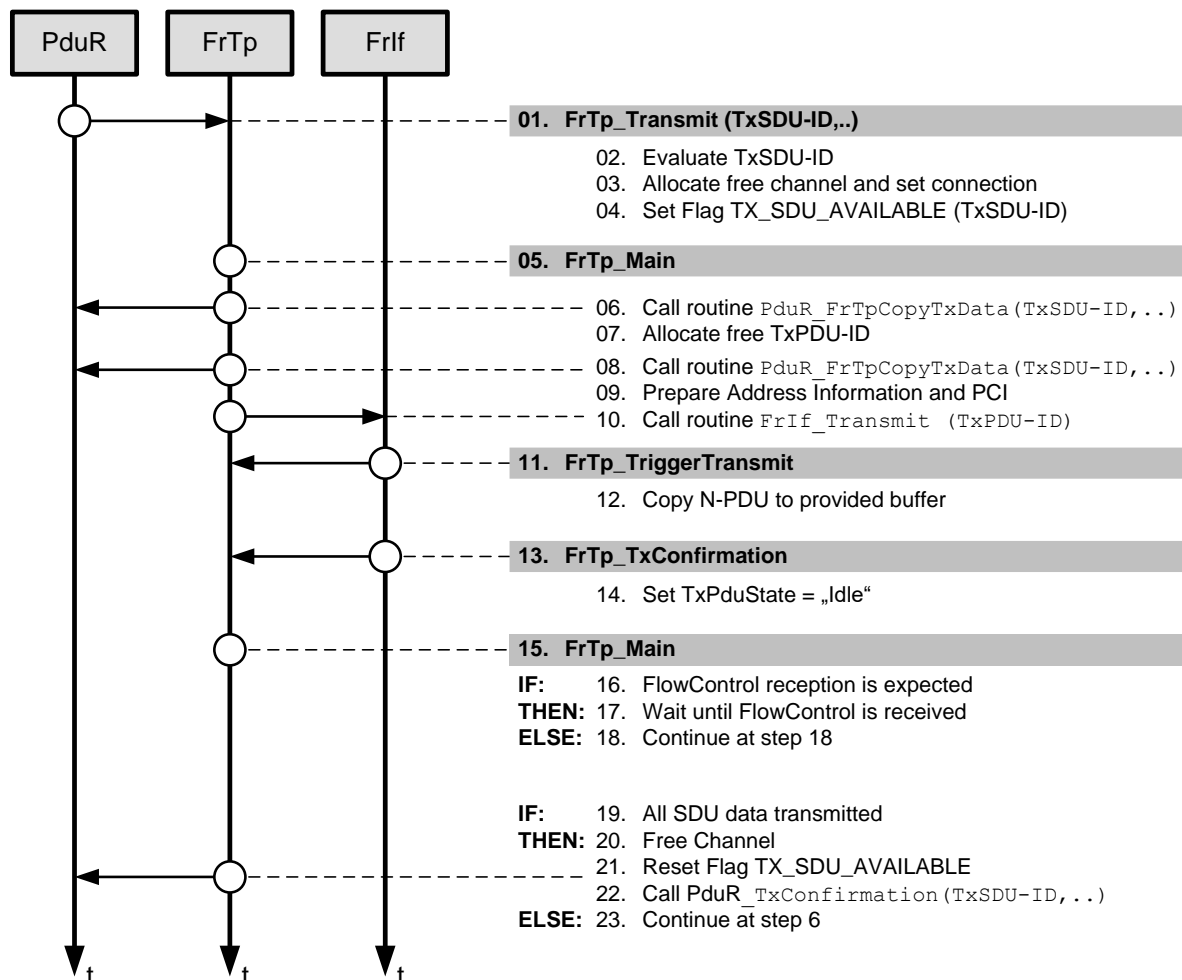

Figure 15: Transmit data overview in ‘Decoupled Buffer Access’ mode

#### Step 01 - 10

Step 01 - 10 in ‘decoupled access mode’ are equal to step 01 – 10 in ‘immediate access mode’. Please refer chapter 7.5.2.1.

For step 09 it is recommended to set the address information and PCI to a local buffer because the service primitive *FrTp\_TriggerTransmit* is called in interrupt

<sup>16</sup> Figure 15 depicts only the overview of data transmission for a single channel without further functionality (e.g. transmit cancellation) or internal behaviour (e.g. internal control data handling, return values etc.). Also a schedule for data transfer in concurrent channels is not described here.

<sup>17</sup> Buffer access mode is configured for each N-PDU (refer to FrIf) and is referenced via the PDU-Pool.

mode and therefore the processing time to copy the complete N-PDU (Address Information, PCI and (part of) SDU data) shall be as short as possible.

### Step 11 - 12

**[SWS\_FrTp\_01059]**      「The service primitive *FrTp\_TriggerTransmit* shall be called by the FrIf module to propagate FrTp N-PDUs to the lower layers (e.g. FlexRay Driver).」()

**[SWS\_FrTp\_01060]**      「The service primitive *FrTp\_TriggerTransmit* shall copy the Address Information, PCI and N-SDU data to the corresponding buffer, which is referenced by the service primitive parameter *PduInfoType*.」()

**[SWS\_FrTp\_01061]**      「The service primitive *FrTp\_TriggerTransmit* shall set the corresponding data length referenced by the service primitive parameter *PduInfoType* to the exact data length of the buffer.」()

### Step 13 - 23

Steps 13 - 23 in 'decoupled access mode' are equal to step 10 – 20 in 'immediate access mode'. Please refer chapter 7.5.2.1.

#### 7.5.2.3 Data Transfer with unknown message length

ISO10681-2 supports the possibility to transmit data with an unknown message length.

**[SWS\_FrTp\_01062]**      「The functionality to support data transmission with unknown message length shall be configurable by compiler switch.」()

**[SWS\_FrTp\_01063]**      「If a 1:n connection is configured (parameter *FRTMP\_MULTIPLE\_RECEIVER\_CON* is set), a Data transfer with unknown message length shall not be processed<sup>18</sup> and the service primitive call *FrTp\_Transmit* shall be rejected with the return value *E\_NOT\_OK*.」()

**[SWS\_FrTp\_01187]**      「The FrTp module shall raise a runtime error *FRTMP\_E\_SEG\_ERROR* when

---

<sup>18</sup> Unknown message length data transfer requires segmentation because at least a StartFrame and a LastFrame have to be transmitted.

- a) a 1:n connection is requested as described in SWS\_FrTp\_01063.  
>()

**[SWS\_FrTp\_01064]** 「 An upper layer's data transmission with unknown message length shall be initiated by an calling the service primitive FrTp\_Transmit with the service primitive parameter PduLength = 0 ('zero') .>()

**[SWS\_FrTp\_01065]** 「 During an ongoing data transfer with unknown message length the service primitive parameter Length of the service primitive PduR\_FrTpCopyTxData() shall be set to the value of the currently stored Tx-Buffer's data bytes.>()

**[SWS\_FrTp\_01066]** 「 An ongoing upper layer's data transmission with unknown message length shall be finished, if the parameter length within the service primitive is set to 0 ('zero').>()

**[SWS\_FrTp\_01067]** 「 The FrTp module shall add all PduInfoType.PduLength values to calculate the total message length which is transmitted by the LastFrame (LF).>()

#### 7.5.2.4 Segmentation condition for data transfer

**[SWS\_FrTp\_01068]** 「 If the FrTpConnectionControl parameter FRTP\_MULTIPLE\_RECEIVER\_CON (see section 10.2) for the corresponding FrTpConnection is set, the communication handler shall not process a segmentation of an N-SDU and take the following actions:

- a) shall raise a runtime error FRTP\_E\_SEG\_ERROR and  
b) shall abort the transmission of this message and notify the upper layer by calling the callback function PduR\_FrTpTxConfirmation with the result E\_NOT\_OK.>()

### 7.5.3 Receive Data

This chapter defines a data reception on FrTp module requested by the lower layer FlexRay Interface (FrIf).

**[SWS\_FrTp\_01206]** 「 During reception, the FrTp shall forward addressing information received as local address and remote address in the N-PDU to the upper layer via the meta data items SOURCE\_ADDRESS\_16 and TARGET\_ADDRESS\_16, and shall use the same address information when transmitting flow control N-PDUs.」()

**[SWS\_FrTp\_01207]** 「 If FrTpLa and/or FrTpRa are not configured for a received N-SDU, any received addressing information can be assigned to this N-SDU. N-SDUs with configured FrTpLa and/or FrTpRa shall be preferred during reception over those without these configuration parameters.」()

Note: The service routine PduR\_FrTpStartOfReception() shall be called in either FrTp\_MainFunction() or FrTp\_RxIndication().

Figure 16 depicts the internal processing for data reception in principle<sup>19</sup>. Below there is a description of the different steps which are necessary to receive data via FrTp.

---

<sup>19</sup> Figure 16 depicts only an overview of data reception for a single channel without further functionality (e.g. transmit cancellation) or internal behaviour (e.g. internal control data handling, return values etc.). Also a schedule for data transfer in concurrent channels is also not described here.

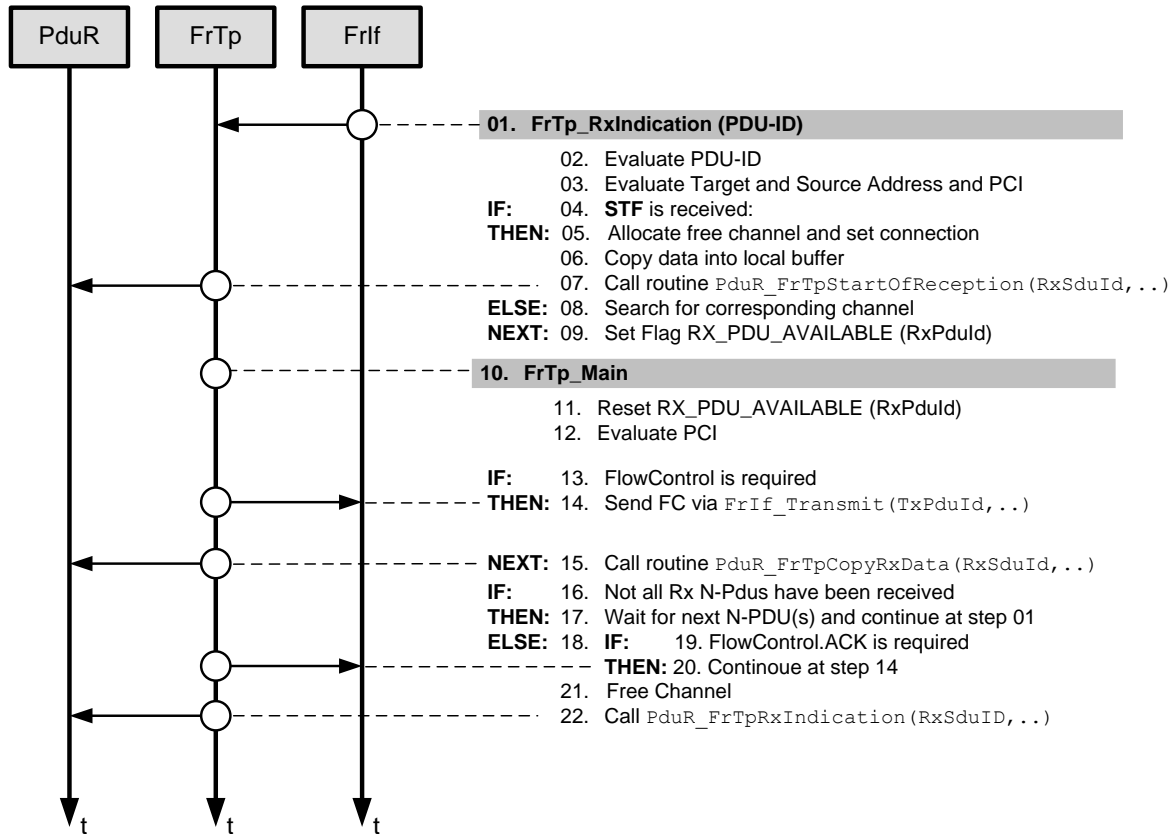

Figure 16: Receive data overview (*FrTp\_RxIndication()* shall call *PduR\_FrTpStartOfReception()* routine)

**Step 1 - 9**

[SWS\_FrTp\_00137] Receiving shall be initiated by the service primitive call *FrTp\_RxIndication. \_()*

The FrTp module shall validate the *RxPduId*. If an invalid *RxPduId* is received, the service primitive *FrTp\_RxIndication* is terminated. For a valid *RxPduId* the FrTp module evaluates the target and source address and selects the corresponding *FrTpConnection*. If a Startframe (STF) is received a free *FrTpChannel* resource (*FrTpRxChannelState* = *Idle*) has to be allocated for that connection. A call of the service primitive *PduR\_FrTpStartOfReception* signals a new data reception to the upper layer.

If a consecutive frame (CF) or a last frame (LF) has been received, the corresponding channel has to be evaluated and the *Rx\_PDU\_AVAILABLE* flag shall be set.

[SWS\_FrTp\_01069] The FrTp module shall process a received FrTp N-PDU only if  
a) a valid *RxPduId* is received and



- b) the FrTp N-PDU's address information matches to the configured FrTpConnection address information.」()

**[SWS\_FrTp\_01070]** 「If an invalid (undefined) RxPduld is received the FrTp module shall

- a) ignore the FrTp N-PDU and
- b) shall raise an development error FRTP\_E\_INVALID\_PDU\_SDU\_ID when development error detection for the FrTp module is enabled.」()

**[SWS\_FrTp\_01071]** 「A matching FrTpConnection is only identified if

- c) the received FrTp N-PDU's "Target Address" (see ISO 10681-2) is equal to the configured FrTpConnection's Local Address (FrTpLa, see section 10.2) and
- d) the received FrTp N-PDU's "Source Address" (see ISO 10681-2) is equal to the configured FrTpConnection's Remote Address (FrTpRa, see section 10.2).」()

**[SWS\_FrTp\_01072]** 「If the address check doesn't match to any configured FrTpConnection the received FrTp N-PDU shall be ignored.」()

**[SWS\_FrTp\_01074]** 「The service primitive shall set the flag RX\_PDU\_AVAILABLE only, if

- a) the requested RxPduld is valid and
- b) the address check matches to a configured FrTpConnection and
- c) a free channel resource is available (FrTpRxChannelState = Idle)」()

**[SWS\_FrTp\_01075]** 「If the current parameter RxPduld is not supported the service primitive FrTp\_RxIndication shall be terminated without any further action.<sup>20</sup>」()

**[SWS\_FrTp\_01076]** 「If no free channel is available (FrTpRxChannelState ≠ Idle) the service primitive FrTp\_RxIndication shall be terminated without any further action.<sup>21</sup>」()

**[SWS\_FrTp\_01186]** 「The FrTp module shall raise a runtime error FRTP\_E\_NO\_CHANNEL.」()

<sup>20</sup> If DET is active a corresponding error shall be set.

<sup>21</sup> It is not possible to signal that temporary resource lack to the upper layer because „PduR\_FrTpStartOfReception“ provide no parameter for that case.

**[SWS\_FrTp\_01077]** 「Within the service primitive *FrTp\_RxIndication* the FrTp module shall copy the received StartFrame PDU into a local buffer<sup>22</sup>.」()

**[SWS\_FrTp\_01078]** 「If a new connection is established, the FrTp module shall call the service primitive *PduR\_FrTpStartOfReception* with the corresponding FrTpRxSdu ID and the expected data length to indicate start of data reception for an upper layer.」()

**[SWS\_FrTp\_01193]** 「With the call of *PduR\_FrTpStartOfReception*, the FrTp shall provide the data and size of STF to the upper layer via *info* parameter of *PduR\_FrTpStartOfReception*.」()

#### Step 10 - 14

According to ISO 10681-2 protocol (evaluate PCI) it is possible that a received N-PDU requires an N-PDU response (e.g. FlowControl). In that case the FrTp module shall allocate the first free N-PDU from the referenced PDU pool, prepare the response and initiate the transmission process by a service primitive call *FrIf\_Transmit* with the corresponding *TxPduId*. After transmission the FrTp module shall wait for reception of consecutive N-PDUs. If no N-PDU response is required by protocol the FrTp module shall continue reception handling.

**[SWS\_FrTp\_01080]** 「If transmission of an N-PDU response is required by ISO10681-2 protocol handling, the FrTp module shall send the corresponding N-PDU (e.g. FlowControl) to the initial sender node.」()

#### Step 15

**[SWS\_FrTp\_01079]** 「The FrTp module shall extract the N-SDU data from the received N-PDU data according to ISO 10681-2.」()

**[SWS\_FrTp\_01138]** 「The FrTp module shall initiate the copy process of the received N-SDU (fragment) by calling the service primitive *PduR\_FrTpCopyRxData*<sup>23</sup>.」()

---

<sup>22</sup> Only the received StartFrame PDU shall be stored temporarily in a local buffer. This is necessary in case of a gateway has temporarily no free resources to process that frame. The correct protocol and timing behaviour is ensured if FrTp sends a FlowControl PDU after a free channel was allocated.

<sup>23</sup> The procedure is also used for the "Routing-On-The-Fly" behaviour for gateways.

**[SWS\_FrTp\_00421]**     「The RX\_PDU\_AVAILABLE flag shall be cleared when finished processing the Fr N-PDU.」()

### Step 16 - 17

The FrTp module could calculate whether all N-PDUs of an N-SDU are received. If the communication is still ongoing the FrTp module shall continue data reception at step 01.

### Step 18 - 22

If all FrTp Rx-PDUs of a complete N-SDU transmission have been received the FrTp module shall send an Acknowledgement if required and free the allocated channel resource. In a next step the FrTp module shall call the service primitive *PduR\_FrTpRxIndication* with the corresponding FrTpRxSdu ID to signal upper layers that an N-SDU has been received.

**[SWS\_FrTp\_01081]**     「The FrTp module shall free the allocated channel (*FrTpRxChannelState* = *Idle*) if

- a) all N-SDU data are received and
- b) all required response N-PDUs (*FlowControl*) are transmitted and *TxConfirmation* was given with result *E\_OK*.

Or

- c) *FrTp\_TxConfirmation* was given with result *E\_NOT\_OK*.」()

**[SWS\_FrTp\_01083]**     「The FrTp module shall always call the service primitive *PduR\_FrTpRxIndication* after *PduR\_FrTpStartOfReception* succeeded. The result shall be *E\_OK* if

- a) all N-SDU data are received and
- b) all required response N-PDUs (*FlowControl*) are transmitted and *TxConfirmation* was given.」()

#### 7.5.3.1 Receive with unknown message length

The FrTp according to ISO 10681-2 provides a method to receive data with unknown message length.

**[SWS\_FrTp\_01184]**     「If a data reception with unknown message length shall be established, the FrTp shall call the API *PduR\_FrTpStartOfReception* () with an expected data length of zero ("0").」()

**Note:** If the API *PduR\_FrTpStartOfReception* () is called with a data length of zero ("0") the upper modul shall provide the maximum buffer size that is currently available.

ECU scenario:

Upper layer, e.g. DCM, shall provide the currently available maximum buffer size.

Gateway scenario:

PduR module shall provide the currently available maximum buffer size.

#### 7.5.4 Buffer Handling

The FrTp module handles received/transmitted data one frame at a time.

During reception it forwards data received from the FrIf directly to the upper layer, no buffering is involved.

During transmission in case of immediate buffer access mode it must provide a temporary buffer to the upper layer which is then directly forwarded to FrIf.

In case of decoupled buffer access mode a static buffer per connection has to be provided to the upper layer and be kept until TriggerTransmit occurs.

The service primitives used to request the upper layer to copy the data from/to the buffers provided by FrTp are: PduR\_FrTpCopyTxData and PduR\_FrTpCopyRxData.

**[SWS\_FrTp\_01196]** 「 If the call for a TxBuffer (service primitive PduR\_FrTpCopyTxData) does not provide a valid buffer and if service primitive notification result type value is BUFREQ\_E\_BUSY, then FrTp module shall try up to FrTpTimeCs times to get a valid buffer.」()

**[SWS\_FrTp\_01197]** 「 If the call for a TxBuffer (service primitive PduR\_FrTpCopyTxData) does not provide a valid buffer (when FrTpTimeCs expired) and if service primitive notification result type value is BUFREQ\_E\_NOT\_OK, then the transfer shall be aborted by calling PduR\_FrTpTxConfirmation with E\_NOT\_OK.」()

##### 7.5.4.1 Buffer Access Mode

**[SWS\_FrTp\_01084]** 「 For Tx direction the FlexRay Transport Protocol Layer shall support  
a) “Immediate Buffer Access” mode and  
b) “Decoupled Buffer Access” mode.」()

## 7.5.5 Dynamic Bandwidth Assignment

From FrTp's point of view physical FlexRay bandwidth is represented by N-PDUs. As depict in Figure 17 there is a direct mapping between N-PDUs and L-PDUs (done within FrLf module's frame construction plan).

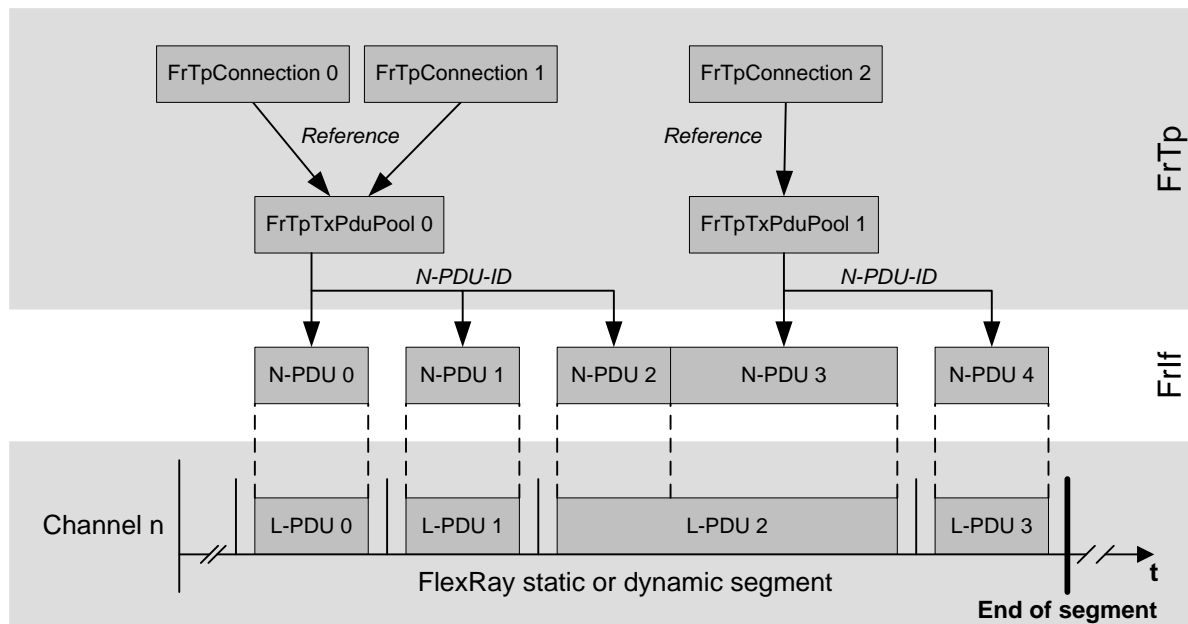

Figure 17: Mapping of N-PDUs to N-PDU-Pools

An FrTpTxPduPool could be referenced by different FrTpConnections (see also chapter 7.3.2.2). Depending on the number of currently active FrTpConnections the bandwidth (N-PDUs) is shared between them<sup>24</sup>. By supporting dynamic bandwidth assignment, a support of different communication scenarios is possible. Figure 18 depicts two different scenarios which could be supported with only one FrTp configuration. From gateway's point of view different communication scenarios are possible:

- a) single connection communication  
Complete bandwidth (slots) is assigned to one communication link (e.g. to ECU 2)
- b) multiple connection communication  
Bandwidth (slots) is shared between different communication links to different ECUs (e.g. ECU 1-3).

<sup>24</sup> Scenario: e.g. gateway communication: For diagnostic communication it is necessary to define a connection to each ECU. In some cases it is required to have a maximum communication in parallel on the other hand it is required to have maximum bandwidth to exactly on ECU (e.g. reprogramming purpose). If dynamic bandwidth assignment is possible, both scenarios are educible with a minimum amount of FlexRay resources ("slots").

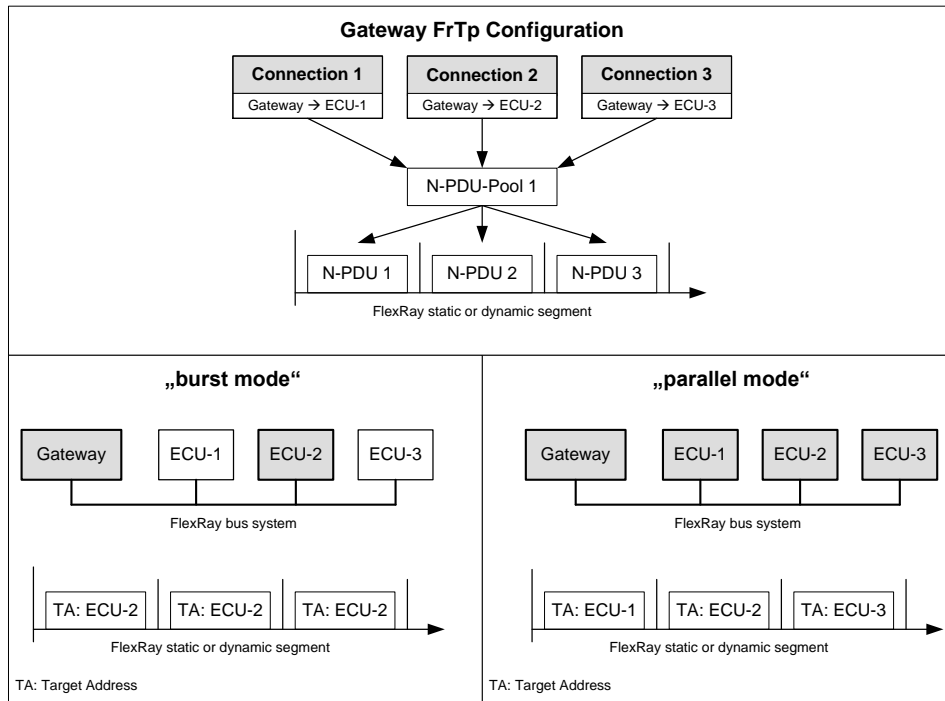

Figure 18: PDU-Pool sharing by different connections

The connection handler controls the partitioning of bandwidth (see Figure 19).

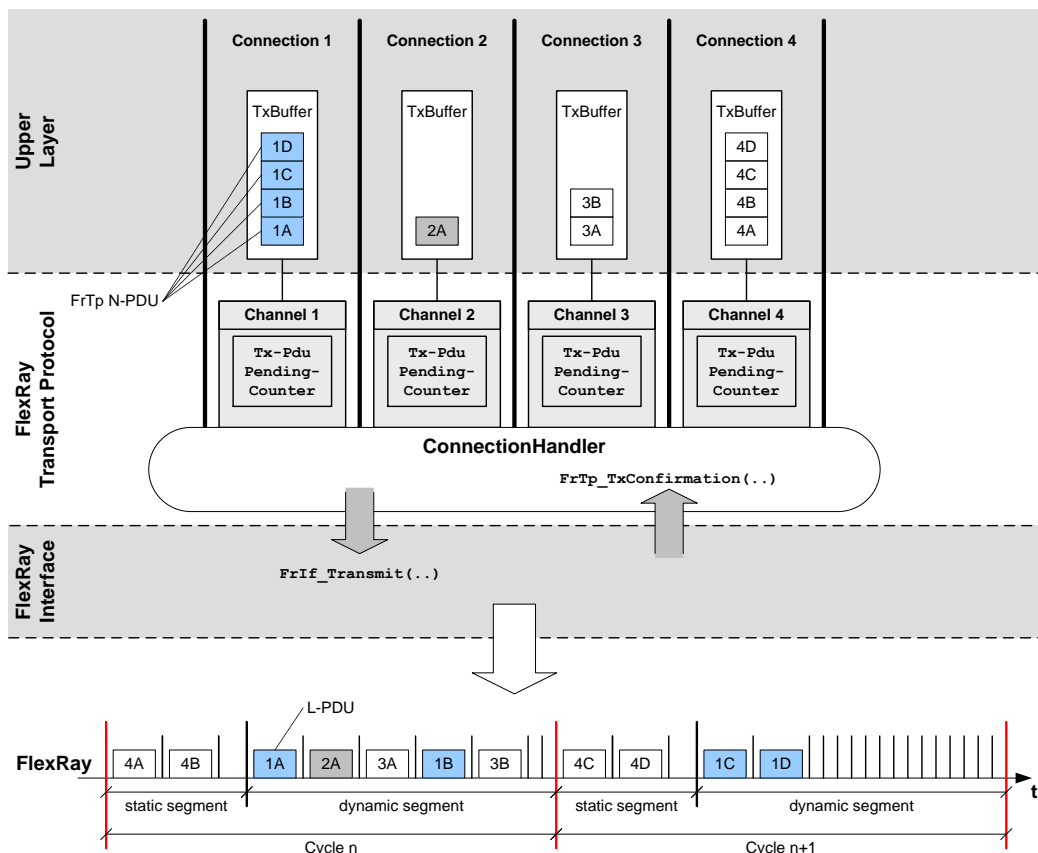

Figure 19: Connection Handler for different connections

The bandwidth assignment can change each communication cycle depending on the active communication links. Especially a gateway could have multiple active communication links in parallel. Hence there are some additional requirements for

the FrTp module to handle concurrent connections. Especially for a segmented data transfer it is necessary to ensure that the connection handler could not swap the order of consecutive frames.<sup>25</sup>

**[SWS\_FrTp\_01088]** 「 All FrTp Tx N-PDUs within an `FrTpTxPduPool` shall be listed in ascending order depending on their position within the global N-PDU network plan<sup>26</sup>.」()

*Note: See also chapter 7.3.2.2*

**[SWS\_FrTp\_01089]** 「Each FrTp Tx N-PDU within an `FrTpTxPduPool` could have an individual length.<sup>27</sup>」()

If more than one FrTp Tx N-PDU is used for data transmission within one connection the number of currently used FrTp Tx N-PDUs has to be controlled. Hence a counter is defined to track all initiated but currently not confirmed FrTp Tx N-PDU transmissions.

**[SWS\_FrTp\_01090]** 「Each `FrTpChannel` shall implement a runtime variable `TxPduPendingCounter` (see chapter 7.3.3.2).」()

**[SWS\_FrTp\_01091]** 「The `TxPduPendingCounter` shall be incremented each time the service primitive `FrIf_Transmit` was terminated with the return value `E_OK` for the corresponding FrTp Tx N-PDU (`TxPduId`).」()

**[SWS\_FrTp\_01092]** 「The `TxPduPendingCounter` shall be decremented each time the service primitive `FrTp_TxConfirmation` was called with the corresponding parameter `FrTpTxConfirmationPduId`.」()

**[SWS\_FrTp\_01093]** 「A `TxConfirmation` shall be given for each transmitted N-PDU by the underlying layer module by calling the corresponding

---

<sup>25</sup> This could occur within the dynamic segment if the transfer of the last L-PDU (including a consecutive frame) is skipped for the current communication cycle and within the next communication cycle other consecutive frames are sent in front of the skipped one.

<sup>26</sup> ECU specific N-PDU plan means that each N-PDU (uniquely identified by its N-PDU-ID) is mapped to an L-PDU. Each L-PDU is uniquely identified by its parameter set “slot-ID”, “cycle counter” and “cycle offset”. Hence all N-PDUs have an implicit order too.

<sup>27</sup> As depicted in Figure 17, at the end of a segment it could occur that only an L-PDU with less payload could be placed in the schedule. Hence the mapped FrTp N-PDU should have the corresponding length to prevent waste of bandwidth.

service primitive `FrTp_TxConfirmation` with the corresponding `FrTpTxConfirmationPduId.()`

The communication handler task shall process an active `FrTpConnection` (referenced by an `FrTpChannel`) only if the corresponding `TxPduPendingCounter` is zero at begin of the task. If the `TxPduPendingCounter` is unequal to zero an `FrTp Tx N-PDU` confirmation is pending and the processing for the corresponding `FrTpConnection` is skipped for the current communication handler task.

**[SWS\_FrTp\_01094]** 「 An active `FrTpConnection` (referenced by `FrTpChannel`) shall only processed if the `TxPduPendingCounter` of the corresponding `FrTpChannel` is zero (“0”) at begin of a communication handler task.」()

**[SWS\_FrTp\_01095]** 「If the `TxPduPendingCounter` is unequal to zero (“0”) the processing for the corresponding `FrTpConnection` shall skipped for the current communication handler task.」()

**[SWS\_FrTp\_01096]** 「A communication handler task shall process all active `FrTpConnections` alternately<sup>28</sup> as long as free `FrTp Tx N-PDUs` are available within the referenced `FrTpTxPduPool.()`

### 7.5.6 Transmit Cancellation

According to ISO 10681-2 the `FrTp` module supports “Transmit Cancellation” for an ongoing `FrTp N-SDU` transfer. This functionality could disable by a global compiler switch. )

**[SWS\_FrTp\_01097]** 「The “Transmit Cancellation” feature shall be (de)activated by static configuration of the `FrTp` parameter `FrTpTransmitCancellation` (see section 10.2).」()

**[SWS\_FrTp\_00384]** 「A Transmit Cancellation request shall be done by the call of the service primitive `FrTp_CancelTransmit()` (see [SWS FrTp\\_00150](#)).」()

**[SWS\_FrTp\_01116]** 「 When a transmission is still in progress, `FrTp_CancelTransmit` shall stop the transmission and shall return

---

<sup>28</sup> Alternate means that a schedule has to be implemented which processes all active `FrTpConnections` with one N-PDU per instance. It is recommended to use a simple round-robin method but other schedules are also possible.



E\_OK. When a connection is not active, or when the last N-PDU of a transmission without acknowledgement has already been forwarded to the Frlf, *FrTp\_CancelTransmit* shall return E\_NOT\_OK.>()

**[SWS\_FrTp\_00385]** If the transmit request is pending but the transmission has not started, *FrTp\_CancelTransmit* (see [SWS\\_FrTp\\_00150](#)) shall immediately free the connection.>()

### 7.5.6.1 Transmit Cancellation for unsegmented data transfer

A Transmit Cancellation request for an unsegmented data transfer could occur on two different positions within FrTp module's processing:

- a) Before sending the StartFrame (STF)  
The Transmit Cancellation Request is effective.
- b) After sending the StartFrame (STF)  
The Transmit Cancellation Request is not effective because of the StartFrame was sent.

Figure 20 depicts the transmit cancellation behavior of an unsegmented data transfer.

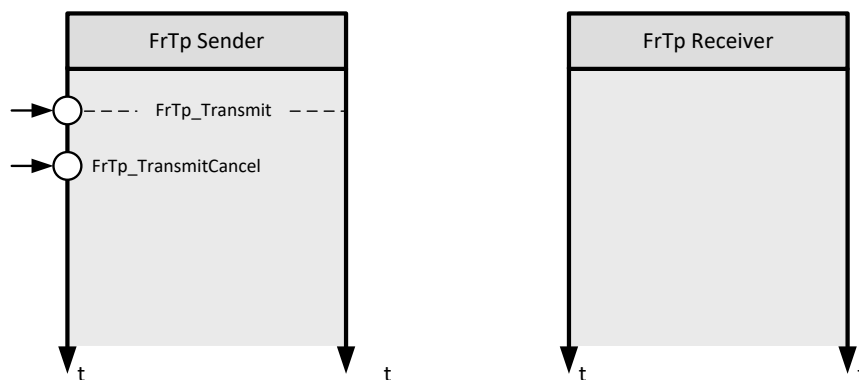

Figure 20: Transmit Cancellation at unsegmented data transfer

If a requested but currently not started data transfer shall be cancelled the service primitive *FrTp\_CancelTransmit()* is called. *FrTp\_CancelTransmit()* shall cancel the requested data transfer. On receiver side no data transfer is recognized.

### 7.5.6.2 Transmit Cancellation for segmented data transfer

A Transmit Cancellation request for a segmented data transfer could occur on three different positions within FrTp module's processing:

- a) Before sending the StartFrame (STF)  
The Transmit Cancellation Request is effective.
- b) Within an ongoing data transfer  
The Transmit Cancellation Request is effective.
- c) After sending the LastFrame (LF)

The Transmit Cancellation Request is not effective because of because after having transmitted the LastFrame (LF) the transmission is finished

Figure 21 depicts the transmit cancellation behavior of a segmented data transfer. If a requested but currently not started data transfer shall be cancelled the service primitive *FrTp\_CancelTransmit* is called. On receiver side no data transfer is recognized.

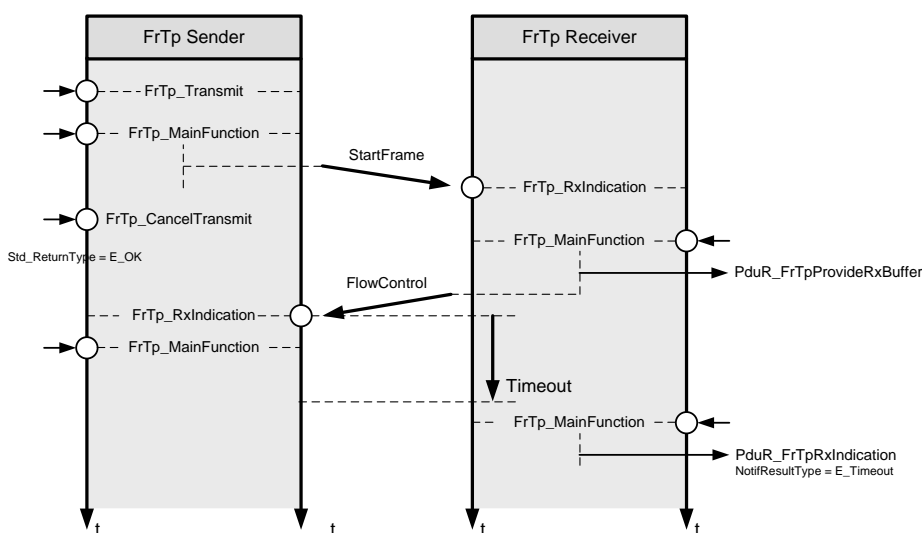

Figure 21: Transmit Cancellation at segmented data transfer

If an ongoing data transfer shall be cancelled, the service primitive *FrTp\_CancelTransmit()* is called. *FrTp\_CancelTransmit()* shall cancel the current data transfer process. On receiver side an initial data reception is recognized and processed (e.g. call of service primitive *PduR\_FrTpStartOfReception*, send FlowControl N-PDU etc.). If the sender cancels data transfer a timeout occurs on receiver side.

If no retry is configured, this timeout is used to cancel the current reception by calling the service primitive *PduR\_FrTpRxIndication* with the corresponding notification result error code.

If retry is configured, the receiver sends an additional FlowControl<sup>29</sup>. After a configured amount of retries the final timeout is used to cancel the current reception by calling the service primitive *PduR\_FrTpRxIndication* with the corresponding notification result error code.

### 7.5.7 Change FrTp Parameter

- [SWS\_FrTp\_00242]**    The FrTp module shall change the ISO10681-2 FlowControl PDU parameter(s) of BandwidthControl (BC)
- a) FrTpSCexp (please refer to ISO 10681-2)

<sup>29</sup> Note: On sender site the additional FlowControl is received as an unexpected N-PDU and is ignored.

b) FrTpMaxNbrOfNPduPerCycle (please refer to ISO 10681-2) during runtime if the corresponding API service primitive *FrTp\_ChangeParameter* is called. ]()

**[SWS\_FrTp\_01195]** 「The layout of the BC parameter shall be identical to the layout in the FC(CTS) frame: The FrTpMaxNbrOfNPduPerCycle shall be placed in bits 3..7, the FrTpSCexp in the bits 0..2. The upper byte of the parameter is not used. ]()

**[SWS\_FrTp\_01115]** 「A change parameter request during an ongoing reception shall be terminated with return value of E\_NOT\_OK. ]()

**[SWS\_FrTp\_01156]** 「The FrTp module shall use the new BandwidthControl parameters for the corresponding connection if the change was successfully executed. ]()

Note: Bandwidth Control is part of the runtime parameter set. For details please refer to chapter 7.3.3.3.

### 7.5.8 Timing parameter and timeout behaviour

The FrTp module requires different timing parameters for communication handling. This chapter defines the timing and timeout behaviour.

**[SWS\_FrTp\_01099]** 「The FrTp module shall support the different timers and their start/stop conditions for communication handling as defined in Figure 22, Figure 23 and Table 2. ]()

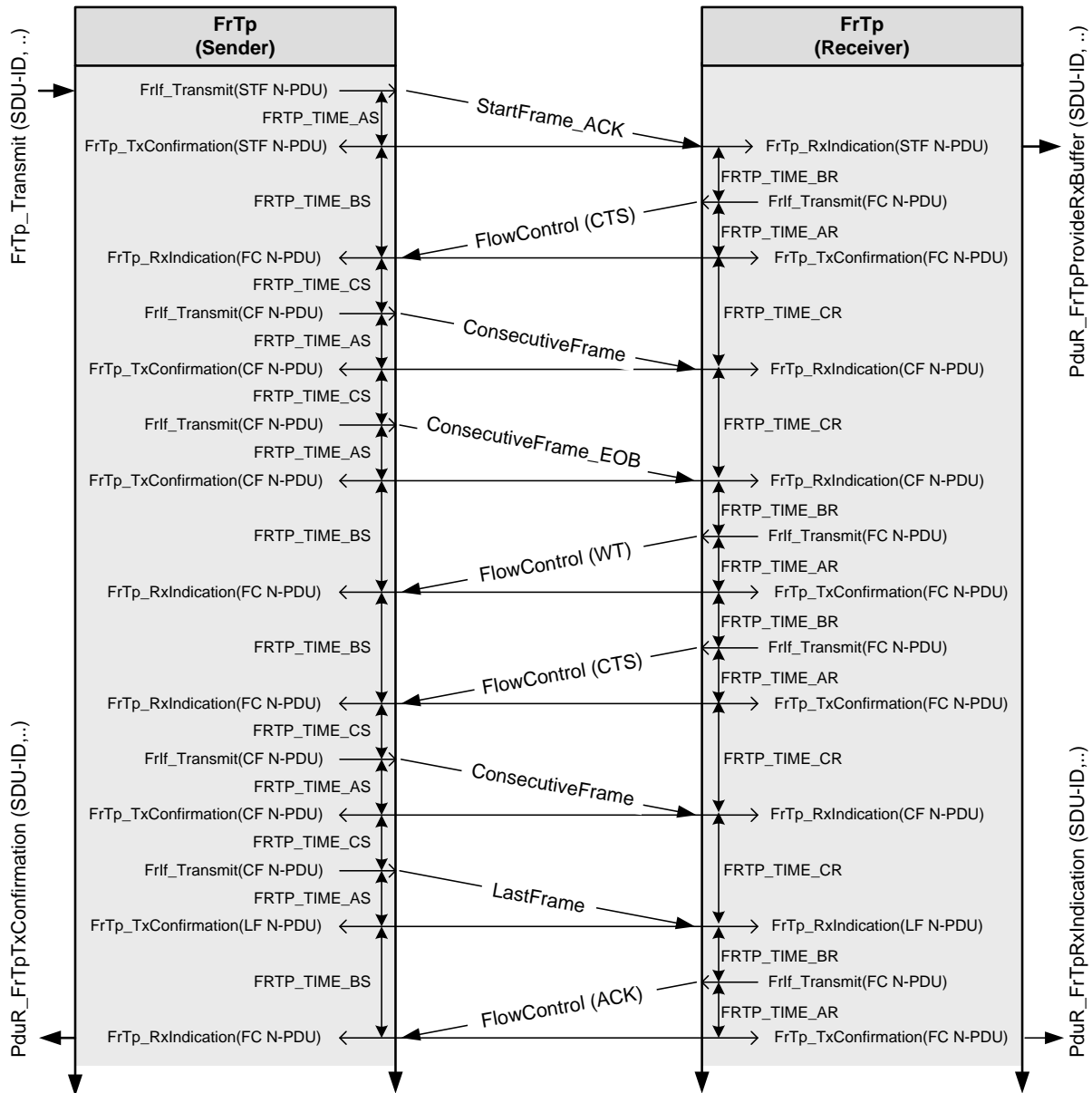

Figure 22: Timing parameter definition for one PDU transmission per Main-Function call

As described above it is possible to transmit more than one N-PDU per connection within on FlexRay Communication Cycle. Hence the communication handler shall be able to call FrLf\_Transmit API several times (depending on available N-PDUs within the Tx-PDU-Pool) independent whether FrTp\_TxConfirmation for the previously transmitted N-PDUs is given. Due to that, timing behavior (e.g. Start FRTP\_Time\_AS etc.) is different too. If more than one N-PDU shall be transmitted within one Main-Function call the timing behaviour is depict in Figure 23.

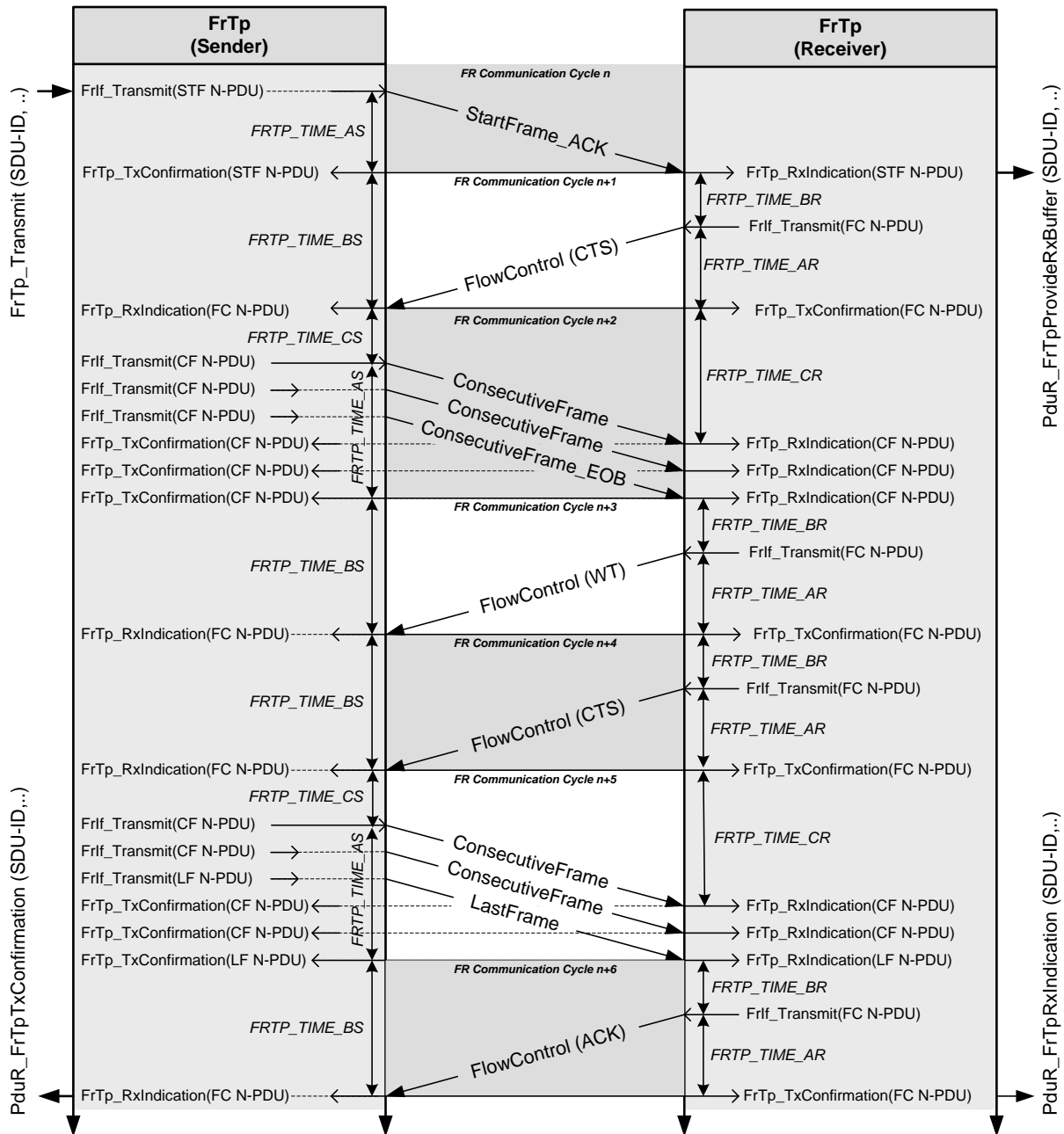

Figure 23: Timing parameter definition for multiple PDU transmission per Main-Function call

Note: Bandwidth Control restricts the number of N-PDUs per Flexray-Cycle. This has an impact to FrTp\_Time\_CS and. Hence that time depends on implementation (task schedule of FrTp\_Main()) and the corresponding FlowControl Parameters) For details please refer to chapter 7.3.3.3.

Timing Parameter	Description	Timer Start Condition	Timer Stop Condition
F RTP_TIME_AS	Time for transmission of any FrTp N-PDU on the sender side. This is a performance requirement. The time depends on implementation and the global FlexRay schedule. The maximum time is controlled by the F RTP_TIMEOUT_AS.	Frlf_Transmit()	FrTp_TxConfirmation()
F RTP_TIME_AR	Time for transmission of FlowControl FrTp N-PDU on the receiver side. This is a performance requirement. The time depends on implementation and the global FlexRay schedule. The maximum time is controlled by the F RTP_TIMEOUT_AR.	Frlf_Transmit()	FrTp_TxConfirmation
F RTP_TIME_BS	Time until reception of the next FlowControl N-PDU. The maximum time is controlled by the F RTP_TIMEOUT_BS.	FrTp_TxConfirmation (STF), FrTp_RxIndication (FC), FrTp_TxConfirmation (CF), FrTp_TxConfirmation (LF)	FrTp_RxIndication (FC)
F RTP_TIME_BR	Time until transmission of the next FlowControl N-PDU.	FrTp_RxIndication (STF), FrTp_TxConfirmation (FC), FrTp_RxIndication (CF), FrTp_RxIndication (LF)	Frlf_Transmit (FC)
F RTP_TIME_CR	Time until reception of the next ConsecutiveFrame N-PDU. The maximum time is controlled by the F RTP_TIMEOUT_CR.	FrTp_TxConfirmation (FC), FrTp_RxIndication (CF)	FrTp_RxIndication (CF) FrTp_RxIndication (LF)
F RTP_TIME_CS	Time (in seconds) until transmission of the next ConsecutiveFrame N-PDU / LastFrame N-PDU.	FrTp_TxConfirmation (CF), FrTp_RxIndication (FC)	Frlf_Transmit (CF)
S/s ... sender R/r ... receiver			

**Table 2: Timing parameter for the FrTp module**

**[SWS\_FrTp\_01100]** 「 The FrTp module shall support the communication timeout behavior as defined in Table 3.」()

Timeout Parameter	Cause	Action
F RTP_TIMEOUT_AS	Any FrTp N-PDU not transmitted in time on the sender side. <sup>30</sup>	Abort message transmission. <sup>31</sup> a) Call FrIf_CancelTransmit() and free the FrTpTxPdu. b) issue PduR_FrTpTxConfirmation with the corresponding FrTpTxSdu ID and E_NOT_OK.
F RTP_TIMEOUT_AR	Any FrTp FC N-PDU not transmitted in time on the receiver side. <sup>32</sup>	Abort message reception and issue PduR_FrTpRxIndication with the corresponding FrTpRxSdu ID.
F RTP_TIMEOUT_BS	FlowControl N-PDU not received (lost, overwritten) on the sender side.	Abort message transmission and issue PduR_FrTpTxConfirmation with the corresponding FrTpTxSdu ID and E_NOT_OK.
F RTP_TIMEOUT_CR	ConsecutiveFrame or Last Frame N-PDU not received (lost, overwritten) on the receiver side. <sup>33</sup>	Abort message reception and issue PduR_FrTpRxIndication with the corresponding FrTpRxSdu ID and E_NOT_OK.
F RTP_TIMEOUT_BR	Any FrTp FC N-PDU transmission is not initiated on the receiver side after receiving the next consecutive frame (STF or last CF of a block or LF) or after the transmit confirmation for the flow control (WT) frame.	Abort message reception and issue PduR_FrTpRxIndication with the corresponding FrTpRxSdu ID.
F RTP_TIMEOUT_CS	Any FrTp CF N-PDU transmission is not initiated on the sender side in time after receiving the flow control frame (CTS).	Abort message transmission and issue PduR_FrTpTxConfirmation with the corresponding FrTpTxSdu ID and E_NOT_OK.

**Table 3: Timeout behaviour for FrTp module**

<sup>30</sup> This could occur if an N-PDU was suspended several times within the dynamic segment.

<sup>31</sup> NOTE: In FlexRay the transmission confirmation doesn't provide an End-To-End confirmation as on other bus protocols (e.g. CAN). This means that a transmission confirmation is provided as soon/only if the L-PDU was passed over to the network. Hence, if no confirmation occurs, the L-PDU is still stuck within the message buffer of the FlexRay controller, which is occupied and cannot be used in the meanwhile.

<sup>32</sup> This could occur if an N-PDU is suspended several times within the dynamic segment.

<sup>33</sup> This could occur in case preceding FlowControl N-PDU not received (lost, overwritten) on overall sender side.

### 7.6 Counters

Several counters are used to handle the different retry attempts. This chapter defines these different counters and their increasing and decreasing behaviour. Each counter is limited by a specified value. The figure below shows the different interactions between timer, counter and function calls.

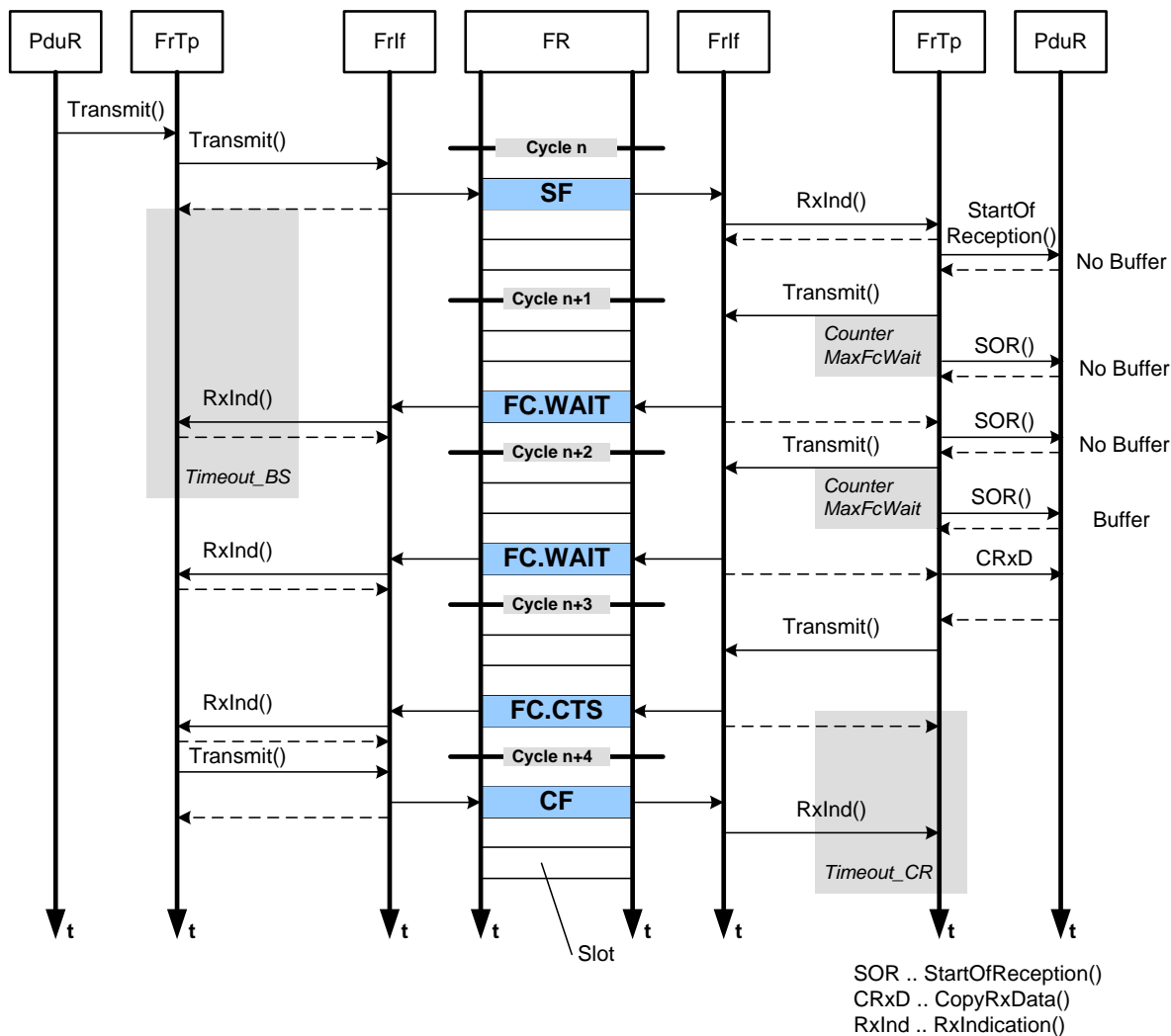

Figure 24: Counter, timer and function call interaction

[SWS\_FrTp\_01105] 「The FrTp module shall support the counters and corresponding limits as defined in Table 4: FrTp Counter.」()

[SWS\_FrTp\_01114] 「Each FrTp Counter shall be limited by a max value as defines in Table 4.」()



Counter Name	Counter Description	Limit
COUNTER_FCWT	On receiver site: Counts the number of transmitted FlowControl.Wait frames <sup>34</sup>	FrTpMaxFCWait
Counter_RX_RN	Counts the transmission retry requests on receiver site initiated due to a frame error, e.g. bad SN in a CF.	FrTpMaxRn

**Table 4: FrTp Counter**

**[SWS\_FrTp\_01113]** If a counter of has been reached, the FrTp module shall react as defined in Table 5.>()

Counter Name	Handling if counter has been reached
COUNTER_FCWT	Abort transmission
COUNTER_RX_RN	<b>Case a) Segmented – Acknowledged transmission</b> 1) Abort reception by calling service primitive PduR_FrTpRxIndication with E_NOT_OK 2) Send FlowControl.ABT (if aFlowControl is possible)

**Table 5: FrTp module reaction if counters reached**

<sup>34</sup> The limit of COUNTER\_FCWT shall be in relation to the task to get an RxBuffer (service primitive call PduR\_FrTpCopyRxData). The frequency of buffer request retries must be equal/higher than the FC.WAIT transmission frequency.

## 7.7 Error Classification

Section 7.x "Error Handling" of the document "General Specification of Basic Software Modules" describes the error handling of the Basic Software in detail. Above all, it constitutes a classification scheme consisting of five error types which may occur in BSW modules.

Based on this foundation, the following section specifies particular errors arranged in the respective subsections below.

### 7.7.1 Development Errors

#### [SWS\_FrTp\_01201]

<i>Type of error</i>	<i>Related error code</i>	<i>Error value</i>
API service call without module initialization: Exception: a) FrTp_Init() b) FrTp_GetVersionInfo()	F RTP_E_UNINIT	0x01
NULL-Pointer on any API call	F RTP_E_PARAM_POINTER	0x02
API call with invalid SDU-ID (PduR) or PDU-ID (FrIf)	F RTP_E_INVALID_PDU_SDU_ID	0x03
API call with invalid Parameter	F RTP_E_INVALID_PARAMETER	0x04
Transmission of unknown message length is detected but not configured.	F RTP_E_UMSG_LENGTH_ERROR	0x06
FrTp initialization has been failed; e.g. selected configuration set doesn't exist.	F RTP_E_INIT_FAILED	0x08

l()

### 7.7.2 Runtime Errors

#### [SWS\_FrTp\_01208]

<i>Type of error</i>	<i>Related error code</i>	<i>Error value</i>
Segmentation is required for a 1:n connection	F RTP_E_SEG_ERROR	0x05
No free channel available	F RTP_E_NO_CHANNEL	0x07

l()

### **7.7.3 Transient Faults**

There are no transient faults.

### **7.7.4 Production Errors**

There are no production errors.

### **7.7.5 Extended Production Errors**

There are no extended production errors.

## 8 API specification

### 8.1 Imported types

This chapter lists all included types for FlexRay Transport Layer and their corresponding header files.

**[SWS\_FrTp\_00141]** 「Std\_ReturnType shall be imported from Std\_Types.h.」()

**[SWS\_FrTp\_01164]** 「Std\_VersionInfoType shall be imported from Std\_Types.h.」()

**[SWS\_FrTp\_01165]** 「BufReq\_ReturnType shall be imported from ComStack\_Types.h.」()

**[SWS\_FrTp\_01167]** 「PduldType shall be imported from ComStack\_Types.h.」()

**[SWS\_FrTp\_01168]** 「PdulInfoType shall be imported from ComStack\_Types.h.」()

**[SWS\_FrTp\_01169]** 「PduLengthType shall be imported from ComStack\_Types.h.」()

**[SWS\_FrTp\_01170]** 「RetryInfoType shall be imported from ComStack\_Types.h.」()

**[SWS\_FrTp\_01178]** 「TPParameterType shall be imported from ComStack\_Types.h.」()

「」

Module	Header File	Imported Type
ComStack_Types	ComStack_Types.h	BufReq_ReturnType
	ComStack_Types.h	PduldType
	ComStack_Types.h	PdulInfoType
	ComStack_Types.h	PduLengthType
	ComStack_Types.h	RetryInfoType
	ComStack_Types.h	TPParameterType
	ComStack_Types.h	TpDataStateType
Std	Std_Types.h	Std_ReturnType
	Std_Types.h	Std_VersionInfoType

」()

## 8.2 Type definitions

### 8.2.1 FrTp\_ConfigType

The post-build-time configuration fulfills two functionalities:

- Post-build selectable, where more than one configuration is located in the ECU, and one is selected at init of the FrTp module
- Post-build loadable, where one configuration is located in the ECU. This configuration may be reprogrammed after compile-time

Basically there is no restriction to mix both selectable and loadable. Typically the post-build loadable is located in its own flash sector where it can be reprogrammed without affecting other modules/applications.

#### [SWS\_FrTp\_01194]

<b>Name</b>	FrTp_ConfigType	
<b>Kind</b>	Structure	
<b>Elements</b>	implementation specific	
	<b>Type</b>	--
	<b>Comment</b>	--
<b>Description</b>	<p>This is the base type for the configuration of the FlexRay Transport Protocol</p> <p>A pointer to an instance of this structure will be used in the initialization of the Flex Ray Transport Protocol.</p> <p>The outline of the structure is defined in chapter 10 Configuration Specification</p>	
<b>Available via</b>	FrTp.h	

()

## 8.3 Function definitions

### 8.3.1 Standard functions

#### 8.3.1.1 FrTp\_GetVersionInfo

#### [SWS\_FrTp\_00215]

<b>Service Name</b>	FrTp_GetVersionInfo
<b>Syntax</b>	<pre>void FrTp_GetVersionInfo (     Std_VersionInfoType* versioninfo )</pre>
<b>Service ID [hex]</b>	0x27

<b>Sync/Async</b>	Synchronous	
<b>Reentrancy</b>	Reentrant	
<b>Parameters (in)</b>	None	
<b>Parameters (inout)</b>	None	
<b>Parameters (out)</b>	versioninfo	Pointer to where to store the version information of this module.
<b>Return value</b>	None	
<b>Description</b>	Returns the version information.	
<b>Available via</b>	FrTp.h	

⌋(SRS\_BSW\_00407)

**[SWS\_FrTp\_00498]** ⌈The function FrTp\_GetVersionInfo shall be pre compile time configurable On/Off by the configuration parameter:

*FrTpVersionInfoApi*⌋()

**[SWS\_FrTp\_01150]** ⌈ If development error detection for the FrTp\_GetVersionInfo is enabled: the function FrTp\_GetVersionInfo shall check the parameter versioninfo for being valid. If the check for FrTpRxDulInfoPtr fails, the function FrTp\_GetVersionInfo shall raise the development error FRTP\_E\_PARAM\_POINTER and return E\_NOT\_OK.

⌋()

## 8.3.2 Initialization and Shutdown

### 8.3.2.1 FrTp\_Init

**[SWS\_FrTp\_00147]**⌈

<b>Service Name</b>	FrTp_Init	
<b>Syntax</b>	<pre>void FrTp_Init (     const FrTp_ConfigType* configPtr )</pre>	
<b>Service ID [hex]</b>	0x00	
<b>Sync/Async</b>	Synchronous	
<b>Reentrancy</b>	Non Reentrant	
<b>Parameters (in)</b>	configPtr	Pointer to FlexRay Transport Protocol configuration.
<b>Parameters</b>	None	

<b>(inout)</b>	
<b>Parameters (out)</b>	None
<b>Return value</b>	None
<b>Description</b>	This service initializes all global variables of a FlexRay Transport Layer instance and set it in the idle state. It has no return value because software errors in initialisation data shall be detected during configuration time (e.g. by configuration tool).
<b>Available via</b>	FrTp.h

](SRS\_BSW\_00101)

### 8.3.2.2 FrTp\_Shutdown

[SWS\_FrTp\_00148][

<b>Service Name</b>	FrTp_Shutdown
<b>Syntax</b>	<pre>void FrTp_Shutdown (     void )</pre>
<b>Service ID [hex]</b>	0x01
<b>Sync/Async</b>	Synchronous
<b>Reentrancy</b>	Non Reentrant
<b>Parameters (in)</b>	None
<b>Parameters (inout)</b>	None
<b>Parameters (out)</b>	None
<b>Return value</b>	None
<b>Description</b>	This service closes all pending transport protocol connections by simply stopping operation, frees all resources and stops the FrTp Module
<b>Available via</b>	FrTp.h

]()

### 8.3.3 Normal Operation

#### 8.3.3.1 FrTp\_Transmit

[SWS\_FrTp\_00149][

<b>Service Name</b>	FrTp_Transmit	
<b>Syntax</b>	Std_ReturnType FrTp_Transmit ( PduIdType TxPduId, const PduInfoType* PduInfoPtr )	
<b>Service ID [hex]</b>	0x49	
<b>Sync/Async</b>	Synchronous	
<b>Reentrancy</b>	Reentrant for different Pdulds. Non reentrant for the same Pdul.	
<b>Parameters (in)</b>	TxPdul	Identifier of the PDU to be transmitted
	PdulInfoPtr	Length of and pointer to the PDU data and pointer to Meta Data.
<b>Parameters (inout)</b>	None	
<b>Parameters (out)</b>	None	
<b>Return value</b>	Std_Return-Type	E_OK: Transmit request has been accepted. E_NOT_OK: Transmit request has not been accepted.
<b>Description</b>	Requests transmission of a PDU.	
<b>Available via</b>	FrTp.h	

J()

Note: The service primitive FrTp\_Transmit sets the flag TX\_SDU\_AVAILABLE if new data are available for transmission.

**[SWS\_FrTp\_01139]** If development error detection for the FrTp\_Transmit is enabled: the function FrTp\_Transmit shall check the parameter TxPdul for being valid. If the check for TxPdul fails, the function FrTp\_Transmit shall raise the development error FRTP\_E\_INVALID\_PDU\_SDU\_ID and return E\_NOT\_OK.J()

**[SWS\_FrTp\_01140]** If development error detection for the FrTp\_Transmit is enabled: the function FrTp\_Transmit shall check the parameter PdulInfoPtr for being valid. If the check for PdulInfoPtr fails, the function FrTp\_Transmit shall raise the development error FRTP\_E\_PARAM\_POINTER and return E\_NOT\_OK.J()

### 8.3.3.2 FrTp\_CancelTransmit

**[SWS\_FrTp\_00150]**

<b>Service Name</b>	FrTp_CancelTransmit
<b>Syntax</b>	Std_ReturnType FrTp_CancelTransmit ( PduIdType TxPduId, const PduInfoType* PduInfoPtr )



	<pre>                 PduIdType TxPduId             )         </pre>	
<b>Service ID [hex]</b>	0x4a	
<b>Sync/Async</b>	Synchronous	
<b>Reentrancy</b>	Reentrant for different Pdulds. Non reentrant for the same Pdulds.	
<b>Parameters (in)</b>	TxPdulds	Identification of the PDU to be cancelled.
<b>Parameters (inout)</b>	None	
<b>Parameters (out)</b>	None	
<b>Return value</b>	Std_Return- Type	E_OK: Cancellation was executed successfully by the destination module. E_NOT_OK: Cancellation was rejected by the destination module.
<b>Description</b>	Requests cancellation of an ongoing transmission of a PDU in a lower layer communication module.	
<b>Available via</b>	FrTp.h	

⌋()

**[SWS\_FrTp\_01141]** ⌈ If development error detection for the FrTp\_CancelTransmit is enabled: the function FrTp\_CancelTransmit shall check the parameter TxPdulds for being valid. If the check for TxPdulds fails, the function FrTp\_CancelTransmit shall raise the development error FRTP\_E\_INVALID\_PDU\_SDU\_ID and return E\_NOT\_OK.⌋()

### 8.3.3.3 FrTp\_ChangeParameter

**[SWS\_FrTp\_00151]**

<b>Service Name</b>	FrTp_ChangeParameter	
<b>Syntax</b>	<pre> Std_ReturnType FrTp_ChangeParameter (     PduIdType id,     TPPParameterType parameter,     uint16 value )         </pre>	
<b>Service ID [hex]</b>	0x4b	
<b>Sync/Async</b>	Synchronous	
<b>Reentrancy</b>	Non Reentrant	
<b>Parameters (in)</b>	id	Identification of the PDU which the parameter change shall affect.

	parameter	ID of the parameter that shall be changed.
	value	The new value of the parameter.
<b>Parameters (inout)</b>	None	
<b>Parameters (out)</b>	None	
<b>Return value</b>	Std_Return-Type	E_OK: The parameter was changed successfully. E_NOT_OK: The parameter change was rejected.
<b>Description</b>	Request to change a specific transport protocol parameter (e.g. block size).	
<b>Available via</b>	FrTp.h	

]()

Note: The service FrTp\_ChangeParameter is used to change the transport protocol parameter Bandwidth Control (BC).

**[SWS\_FrTp\_01143]** If development error detection for the FrTp\_ChangeParameter is enabled: the function FrTp\_ChangeParameter shall check the parameter Id for being valid. If the check for Id fails, the function FrTp\_ChangeParameter shall raise the development error `FRTP_E_INVALID_PDU_SDU_ID` and return `E_NOT_OK. ]()`

**[SWS\_FrTp\_01144]** If development error detection for the FrTp\_ChangeParameter is enabled: the function FrTp\_ChangeParameter shall check the parameter for being valid. If the check for parameter fails, the function FrTp\_ChangeParameter shall raise the development error `FRTP_E_INVALID_PARAMETER` and return `E_NOT_OK. ]()`

### 8.3.3.4 FrTp\_CancelReceive

**[SWS\_FrTp\_01172]**

<b>Service Name</b>	FrTp_CancelReceive	
<b>Syntax</b>	Std_ReturnType FrTp_CancelReceive ( PduIdType RxPduId )	
<b>Service ID [hex]</b>	0x4c	
<b>Sync/Async</b>	Synchronous	
<b>Reentrancy</b>	Non Reentrant	
<b>Parameters (in)</b>	RxPduId	Identification of the PDU to be cancelled.
<b>Parameters</b>	None	

<b>(inout)</b>		
<b>Parameters (out)</b>	None	
<b>Return value</b>	Std_Return-Type	E_OK: Cancellation was executed successfully by the destination module. E_NOT_OK: Cancellation was rejected by the destination module.
<b>Description</b>	Requests cancellation of an ongoing reception of a PDU in a lower layer transport protocol module.	
<b>Available via</b>	FrTp.h	

]()

**[SWS\_FrTp\_01180]** If development error detection is enabled:

The function FrTp\_CancelReceive shall check the parameter RxPduld for being valid. If the check for RxPduld fails, the function shall raise the development error FRTP\_E\_INVALID\_PDU\_SDU\_ID and return E\_NOT\_OK.]()

**[SWS\_FrTp\_01181]** The FrTp shall abort the reception of the current N-PDU if the service FrTp\_CancelReceive provides a valid RxPduld.]()

**[SWS\_FrTp\_01182]** The FrTp shall reject the request for receive cancellation in case of an

- unsegmented reception or
- in case the FrTp is in the process of receiving the LastFrame of the N-SDU

and shall return E\_NOT\_OK.]()

**[SWS\_FrTp\_01183]** If the FrTp\_CancelReceive service has been successfully Executed, FrTp\_CancelReceive shall return with result E\_OK.]()

## 8.4 Call-back notifications

### 8.4.1 FrTp\_TriggerTransmit

**[SWS\_FrTp\_00154]**[

<b>Service Name</b>	FrTp_TriggerTransmit
<b>Syntax</b>	Std_ReturnType FrTp_TriggerTransmit ( PduIdType TxPduId, PduInfoType* PduInfoPtr )

<b>Service ID [hex]</b>	0x41	
<b>Sync/Async</b>	Synchronous	
<b>Reentrancy</b>	Reentrant for different PduIds. Non reentrant for the same PduId.	
<b>Parameters (in)</b>	TxPduId	ID of the SDU that is requested to be transmitted.
<b>Parameters (inout)</b>	PduInfoPtr	Contains a pointer to a buffer (SduDataPtr) to where the SDU data shall be copied, and the available buffer size in SduLength. On return, the service will indicate the length of the copied SDU data in SduLength.
<b>Parameters (out)</b>	None	
<b>Return value</b>	Std_ - Return-Type	E_OK: SDU has been copied and SduLength indicates the number of copied bytes. E_NOT_OK: No SDU data has been copied. PduInfoPtr must not be used since it may contain a NULL pointer or point to invalid data.
<b>Description</b>	Within this API, the upper layer module (called module) shall check whether the available data fits into the buffer size reported by PduInfoPtr->SduLength. If it fits, it shall copy its data into the buffer provided by PduInfoPtr->SduDataPtr and update the length of the actual copied data in PduInfoPtr->SduLength. If not, it returns E_NOT_OK without changing PduInfoPtr.	
<b>Available via</b>	FrTp.h	

]()

**[SWS\_FrTp\_01145]**    If development error detection for the FrTp\_TriggerTransmit is enabled: the function FrTp\_TriggerTransmit shall check the parameter TxPduId for being valid. If the check for TxPduId fails, the function FrTp\_TriggerTransmit shall raise the development error FRTP\_E\_INVALID\_PDU\_SDU\_ID and return E\_NOT\_OK.]()

**[SWS\_FrTp\_01146]**    If development error detection for the FrTp\_TriggerTransmit is enabled: the function FrTp\_TriggerTransmit shall check the parameter PduInfoPtr for being valid. If the check for PduInfoPtr fails, the function FrTp\_TriggerTransmit shall raise the development error FRTP\_E\_PARAM\_POINTER and return E\_NOT\_OK.]()

## 8.4.2 FrTp\_RxIndication

**[SWS\_FrTp\_00152]**[

<b>Service Name</b>	FrTp_RxIndication
<b>Syntax</b>	<pre>void FrTp_RxIndication (     PduIdType RxPduId,     const PduInfoType* PduInfoPtr</pre>

	)	
<b>Service ID [hex]</b>	0x42	
<b>Sync/Async</b>	Synchronous	
<b>Reentrancy</b>	Reentrant for different PduIds. Non reentrant for the same PduId.	
<b>Parameters (in)</b>	RxPduId	ID of the received PDU.
	PduInfoPtr	Contains the length (SduLength) of the received PDU, a pointer to a buffer (SduDataPtr) containing the PDU, and the MetaData related to this PDU.
<b>Parameters (inout)</b>	None	
<b>Parameters (out)</b>	None	
<b>Return value</b>	None	
<b>Description</b>	Indication of a received PDU from a lower layer communication interface module.	
<b>Available via</b>	FrTp.h	

]()

**[SWS\_FrTp\_01147]** If development error detection for the FrTp\_RxIndication is enabled: the function FrTp\_RxIndication shall check the parameter RxPduId for being valid. If the check for RxPduId fails, the function FrTp\_RxIndication shall raise the development error FRTP\_E\_INVALID\_PDU\_SDU\_ID.]()

**[SWS\_FrTp\_01148]** If development error detection for the FrTp\_RxIndication is enabled: the function FrTp\_RxIndication shall check the parameter PduInfoPtr for being valid. If the check for PduInfoPtr fails, the function FrTp\_RxIndication shall raise the development error FRTP\_E\_PARAM\_POINTER.]()

### 8.4.3 FrTp\_TxConfirmation

**[SWS\_FrTp\_00153]**

<b>Service Name</b>	FrTp_TxConfirmation
<b>Syntax</b>	<pre>void FrTp_TxConfirmation (     PduIdType TxPduId,     Std_ReturnType result )</pre>
<b>Service ID [hex]</b>	0x40

<b>Sync/Async</b>	Synchronous	
<b>Reentrancy</b>	Reentrant for different PduIds. Non reentrant for the same PduId.	
<b>Parameters (in)</b>	TxPduId	ID of the PDU that has been transmitted.
	result	E_OK: The PDU was transmitted. E_NOT_OK: Transmission of the PDU failed.
<b>Parameters (inout)</b>	None	
<b>Parameters (out)</b>	None	
<b>Return value</b>	None	
<b>Description</b>	The lower layer communication interface module confirms the transmission of a PDU, or the failure to transmit a PDU.	
<b>Available via</b>	FrTp.h	

⌋()

**[SWS\_FrTp\_01149]** ⌈ If development error detection for the FrTp\_TxConfirmation is enabled: the function FrTp\_TxConfirmation shall check the parameter TxPduId for being valid. If the check for TxPduId fails, the function FrTp\_TxConfirmation shall raise the development error `FRTPE_INVALID_PDU_SDU_ID`.⌋()

**[SWS\_FrTp\_01203]** ⌈ If development error detection is enabled:  
 The function FrTp\_TxConfirmation shall check the parameter result for being valid.  
 If the check for result fails, the function FrTp\_TxConfirmation shall raise the development error `FRTPE_INVALID_PARAMETER`.⌋()

## 8.5 Scheduled functions

Basic Software Scheduler directly calls these functions.

### 8.5.1 FrTp\_MainFunction

**[SWS\_FrTp\_00203]** ⌈ The FrTp\_MainFunction shall be used to schedule the FrTp module.⌋()

**[SWS\_FrTp\_00580]** ⌈ The FrTp\_MainFunction shall be the entry point for FrTp processing tasks.⌋()

**[SWS\_FrTp\_01152]**      「The `FrTp_MainFunction` shall be called at least one time per FlexRay cycle.<sup>35</sup>」()

The `FrTp_MainFunction` shall follow the service primitive definition as described below:

**[SWS\_FrTp\_00162]**

<b>Service Name</b>	FrTp_MainFunction
<b>Syntax</b>	void FrTp_MainFunction ( void )
<b>Service ID [hex]</b>	0x10
<b>Description</b>	Schedules the FlexRay TP. (Entry point for scheduling)
<b>Available via</b>	SchM_FrTp.h

」()

## 8.6 Expected Interfaces

This chapter describes all expected APIs from other modules.

### 8.6.1 Mandatory Interfaces

This chapter defines all mandatory interfaces (API service primitives), which are required in order to fulfill the core functionality of the FrTp module.

**[SWS\_FrTp\_00577]**

<b>API Function</b>	<b>Header File</b>	<b>Description</b>
Det_Report- RuntimeError	Det.h	Service to report runtime errors. If a callout has been configured then this callout shall be called.
FrIf_Transmit	FrIf.h	Requests transmission of a PDU.
PduR_FrTp- CopyRxData	PduR_ FrTp.h	This function is called to provide the received data of an I-PDU segment (N-PDU) to the upper layer. Each call to this function provides the next part of the I-PDU data. The size of the remaining buffer is written to the position indicated by <code>bufferSizePtr</code> .

<sup>35</sup> The number of `MainFunction` calls depends on the global Flexray communication cycle length, the available receive buffers of the FlexRay driver and the implementation (which functionality of transmission and reception could be implemented in interrupt mode). At least one call is necessary to reconfigure the buffers for the corresponding cycle.

If more than one call is necessary it is recommended to call `MainFunction` at the start of the static segment and at the start of the dynamic segment within the communication cycle. If the length of that segments are asymmetric the different segment lengths have to be considered.

PduR_FrTp-CopyTxData	PduR_FrTp.h	This function is called to acquire the transmit data of an I-PDU segment (N-PDU). Each call to this function provides the next part of the I-PDU data unless retry->TpDataState is TP_DATARETRY. In this case the function restarts to copy the data beginning at the offset from the current position indicated by retry->TxTpDataCnt. The size of the remaining data is written to the position indicated by availableDataPtr.
PduR_FrTpRx-Indication	PduR_FrTp.h	Called after an I-PDU has been received via the TP API, the result indicates whether the transmission was successful or not.
PduR_FrTp-StartOf-Reception	PduR_FrTp.h	This function is called at the start of receiving an N-SDU. The N-SDU might be fragmented into multiple N-PDUs (FF with one or more following CFs) or might consist of a single N-PDU (SF). The service shall provide the currently available maximum buffer size when invoked with TpSduLength equal to 0.
PduR_FrTpTx-Confirmation	PduR_FrTp.h	This function is called after the I-PDU has been transmitted on its network, the result indicates whether the transmission was successful or not.

l)

Table 6: FrTp\_MandatoryInterfaces

### 8.6.2 Optional Interfaces

This chapter defines the interfaces, which are required, in order to fulfill the optional functionality of the module.

#### [SWS\_FrTp\_00579]

<i>API function</i>	<i>Description</i>
Det_ReportError	Service to report development errors.
FrIf_CancelTransmit	Wraps the FlexRay Driver API function Fr_CancelTxLPdu

Table 7: FrTp\_OptionalInterfaces

### 8.6.3 Configurable interfaces

No interfaces are defined.



## 9 Sequence diagrams

Although the following sequence diagrams are quite detailed, they do not depict every detail. Thus they should be seen as an addendum to this specification.

### 9.1 Sending of N-Pdus

The flow chart below depicts the sending process' API calls and flag handling. The flow chart shows segmented/unsegmented transfer, Transfer with and without acknowledgement and immediate / decoupled buffer access.

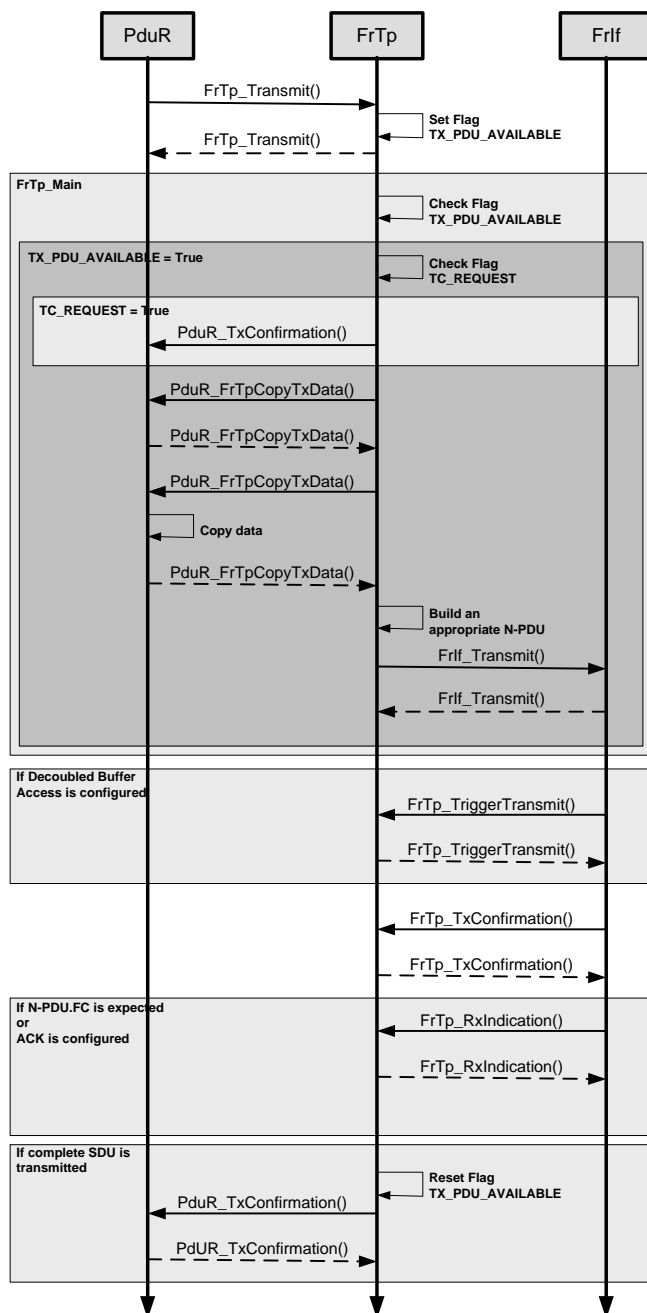
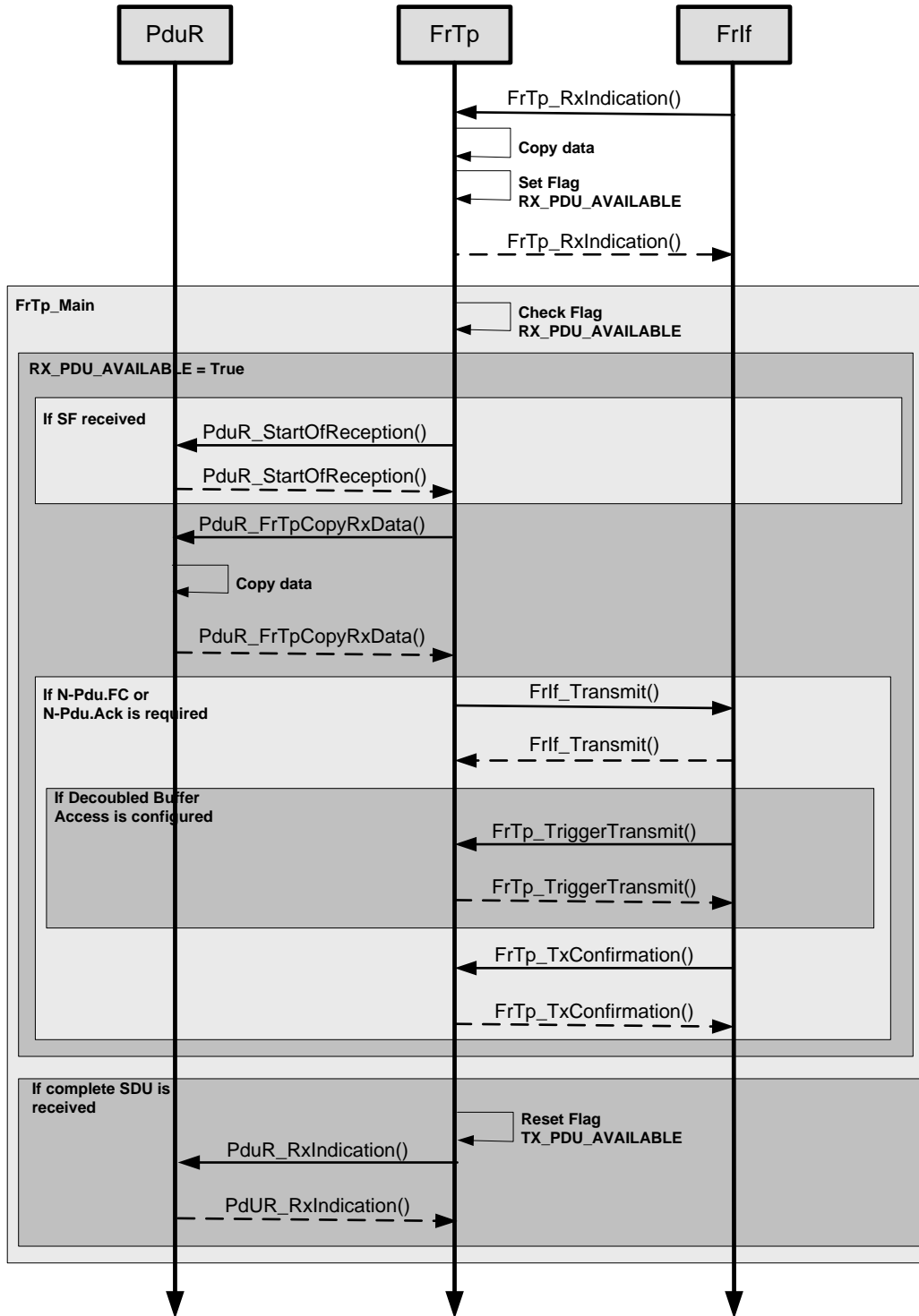

Figure 25: Sending of N-Pdus

### 9.2 Receiving of N-Pdus

The flow chart below depicts the receiving process' API calls and flag handling. The flow chart shows segmented/unsegmented transfer, Transfer with and without acknowledgement and immediate / decoupled buffer access.



**Figure 26: Receiving of N-Pdus (FrTp\_MainFunction() shall call PduR\_FrTpStartOfReception() routine)**

## 10 Configuration specification

This chapter defines configuration parameters and their clustering into containers. In order to support the specification, Chapter 10.1 describes fundamentals.

Chapter 10.2 specifies the structure (containers) and the parameters of the FlexRay Transport Layer module.

Chapter 10.3 specifies published information for the module FlexRay Transport Layer module.

**[SWS\_FrTp\_00569]** 「The configuration tool should extract all information to configure the FlexRay Transport Protocol.」()

### 10.1 How to read this chapter

For details refer to the chapter 10.1 “Introduction to configuration specification” in *SWS\_BSWGeneral*.

## 10.2 Containers and configuration parameters

The following chapters summarize all configuration parameters for the FrTp module.

### 10.2.1 FrTp

<b>SWS Item</b>	[ECUC_FrTp_00001]
<b>Module Name</b>	FrTp
<b>Description</b>	Configuration of the FlexRay Transport Protocol module according to ISO 10681-2.
<b>Post-Build Variant Support</b>	true
<b>Supported Config Variants</b>	VARIANT-POST-BUILD, VARIANT-PRE-COMPILE

Included Containers		
Container Name	Multiplicity	Scope / Dependency
FrTpGeneral	1	This container contains the general configuration parameters of the FlexRay Transport Protocol module.
FrTpMultiple-Config	1	This container contains the configuration parameters and sub containers of the AUTOSAR FrTp module.

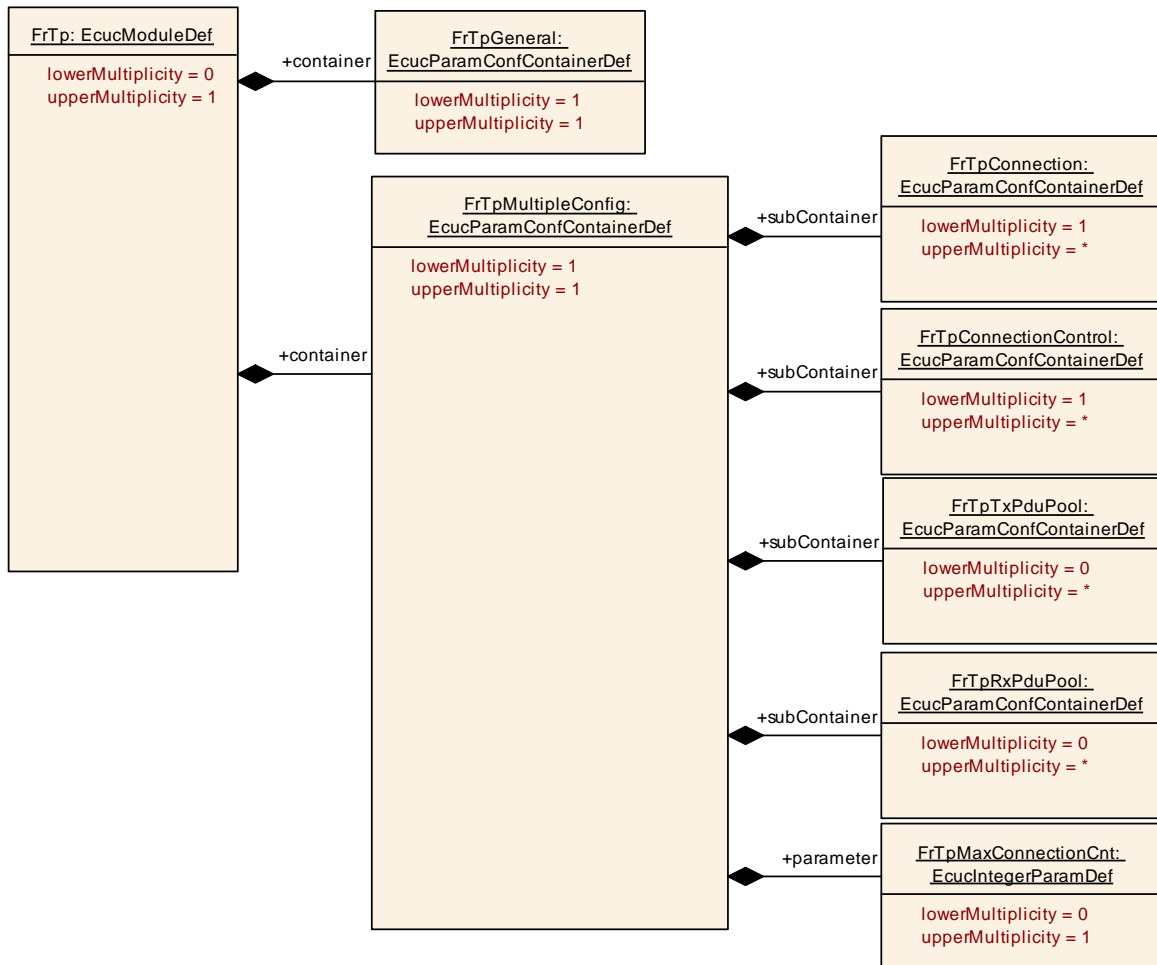

### 10.2.2 FrTpGeneral

<b>SWS Item</b>	[ECUC_FrTp_00009]
<b>Container Name</b>	FrTpGeneral
<b>Parent Container</b>	FrTp
<b>Description</b>	This container contains the general configuration parameters of the FlexRay Transport Protocol module.
<b>Configuration Parameters</b>	

<b>SWS Item</b>	[ECUC_FrTp_00002]
<b>Parameter Name</b>	FrTpAckRt
<b>Parent Container</b>	FrTpGeneral
<b>Description</b>	Preprocessor switch for enabling the Acknowledgement and retry mechanisms.

	True: Acknowledge and Retry is enabled False: Acknowledge and Retry is disabled		
<b>Multiplicity</b>	1		
<b>Type</b>	EcucBooleanParamDef		
<b>Default value</b>	--		
<b>Post-Build Variant Value</b>	false		
<b>Value Configuration Class</b>	<b>Pre-compile time</b>	X	All Variants
	<b>Link time</b>	--	
	<b>Post-build time</b>	--	
<b>Scope / Dependency</b>	scope: local		

<b>SWS Item</b>	[ECUC_FrTp_00052]		
<b>Parameter Name</b>	FrTpChangeParamApi		
<b>Parent Container</b>	FrTpGeneral		
<b>Description</b>	Preprocessor switch for enabling the API to change FrTp communication parameters. True: ChangeParameter API is enabled False: ChangeParameter API is disabled.		
<b>Multiplicity</b>	1		
<b>Type</b>	EcucBooleanParamDef		
<b>Default value</b>	--		
<b>Post-Build Variant Value</b>	false		
<b>Value Configuration Class</b>	<b>Pre-compile time</b>	X	All Variants
	<b>Link time</b>	--	
	<b>Post-build time</b>	--	
<b>Scope / Dependency</b>	scope: local		

<b>SWS Item</b>	[ECUC_FrTp_00004]		
<b>Parameter Name</b>	FrTpChanNum		
<b>Parent Container</b>	FrTpGeneral		
<b>Description</b>	Preprocessor switch for defining the number of concurrent channels the module supports. Up to 32 channels shall be definable here.		
<b>Multiplicity</b>	1		

<b>Type</b>	EcucIntegerParamDef		
<b>Range</b>	1 .. 32		
<b>Default value</b>	--		
<b>Post-Build Variant Value</b>	false		
<b>Value Configuration Class</b>	<b>Pre-compile time</b>	X	All Variants
	<b>Link time</b>	--	
	<b>Post-build time</b>	--	
<b>Scope / Dependency</b>	scope: local		

<b>SWS Item</b>	[ECUC_FrTp_00008]		
<b>Parameter Name</b>	FrTpDevErrorDetect		
<b>Parent Container</b>	FrTpGeneral		
<b>Description</b>	Switches the development error detection and notification on or off. <ul style="list-style-type: none"> <li>• true: detection and notification is enabled.</li> <li>• false: detection and notification is disabled.</li> </ul>		
<b>Multiplicity</b>	1		
<b>Type</b>	EcucBooleanParamDef		
<b>Default value</b>	false		
<b>Post-Build Variant Value</b>	false		
<b>Value Configuration Class</b>	<b>Pre-compile time</b>	X	All Variants
	<b>Link time</b>	--	
	<b>Post-build time</b>	--	
<b>Scope / Dependency</b>	scope: local		

<b>SWS Item</b>	[ECUC_FrTp_00051]		
<b>Parameter Name</b>	FrTpFullDuplexEnable		
<b>Parent Container</b>	FrTpGeneral		
<b>Description</b>	Preprocessor switch for enabling full duplex mechanisms for all channels. True: Full duplex is enabled False: Fullduplex is disabled (Half duplex is enabled)		
<b>Multiplicity</b>	1		
<b>Type</b>	EcucBooleanParamDef		

<b>Default value</b>	false		
<b>Post-Build Variant Value</b>	false		
<b>Value Configuration Class</b>	<b>Pre-compile time</b>	X	All Variants
	<b>Link time</b>	--	
	<b>Post-build time</b>	--	
<b>Scope / Dependency</b>	scope: local		

<b>SWS Item</b>	[ECUC_FrTp_00011]		
<b>Parameter Name</b>	FrTpMainFuncCycle		
<b>Parent Container</b>	FrTpGeneral		
<b>Description</b>	This parameter contains the calling period of the TPs Main Function. The parameter is specified in seconds.		
<b>Multiplicity</b>	1		
<b>Type</b>	EcucFloatParamDef		
<b>Range</b>	]0 .. INF[		
<b>Default value</b>	--		
<b>Post-Build Variant Value</b>	false		
<b>Value Configuration Class</b>	<b>Pre-compile time</b>	X	All Variants
	<b>Link time</b>	--	
	<b>Post-build time</b>	--	
<b>Scope / Dependency</b>	scope: local		

<b>SWS Item</b>	[ECUC_FrTp_00036]		
<b>Parameter Name</b>	FrTpTransmitCancellation		
<b>Parent Container</b>	FrTpGeneral		
<b>Description</b>	Preprocessor switch for enabling Transmit Cancellation and Receive Cancellation. True: Transmit/Receive Cancellation is enabled False: Transmit/Receive Cancellation is disabled		
<b>Multiplicity</b>	1		
<b>Type</b>	EcucBooleanParamDef		
<b>Default value</b>	false		



<b>Post-Build Variant Value</b>	false		
<b>Value Configuration Class</b>	<b>Pre-compile time</b>	X	All Variants
	<b>Link time</b>	--	
	<b>Post-build time</b>	--	
<b>Scope / Dependency</b>	scope: local		

<b>SWS Item</b>	[ECUC_FrTp_00044]		
<b>Parameter Name</b>	FrTpUnknownMsgLength		
<b>Parent Container</b>	FrTpGeneral		
<b>Description</b>	Preprocessor switch to support data transfer with unknown message length. True: Transmission with unknown message length is enabled False: Transmission with unknown message length is disabled		
<b>Multiplicity</b>	1		
<b>Type</b>	EcucBooleanParamDef		
<b>Default value</b>	--		
<b>Post-Build Variant Value</b>	false		
<b>Value Configuration Class</b>	<b>Pre-compile time</b>	X	All Variants
	<b>Link time</b>	--	
	<b>Post-build time</b>	--	
<b>Scope / Dependency</b>	scope: local		

<b>SWS Item</b>	[ECUC_FrTp_00045]		
<b>Parameter Name</b>	FrTpVersionInfoApi		
<b>Parent Container</b>	FrTpGeneral		
<b>Description</b>	Preprocessor switch for enabling the Version info API. True: Version Info API is enabled False: Version Info API is disabled		
<b>Multiplicity</b>	1		
<b>Type</b>	EcucBooleanParamDef		
<b>Default value</b>	false		
<b>Post-Build Variant Value</b>	false		
<b>Value Configuration Class</b>	<b>Pre-compile time</b>	X	All Variants
	<b>Link time</b>	--	

	<b>Post-build time</b>	--	
<b>Scope / Dependency</b>	scope: local		

**No Included Containers**

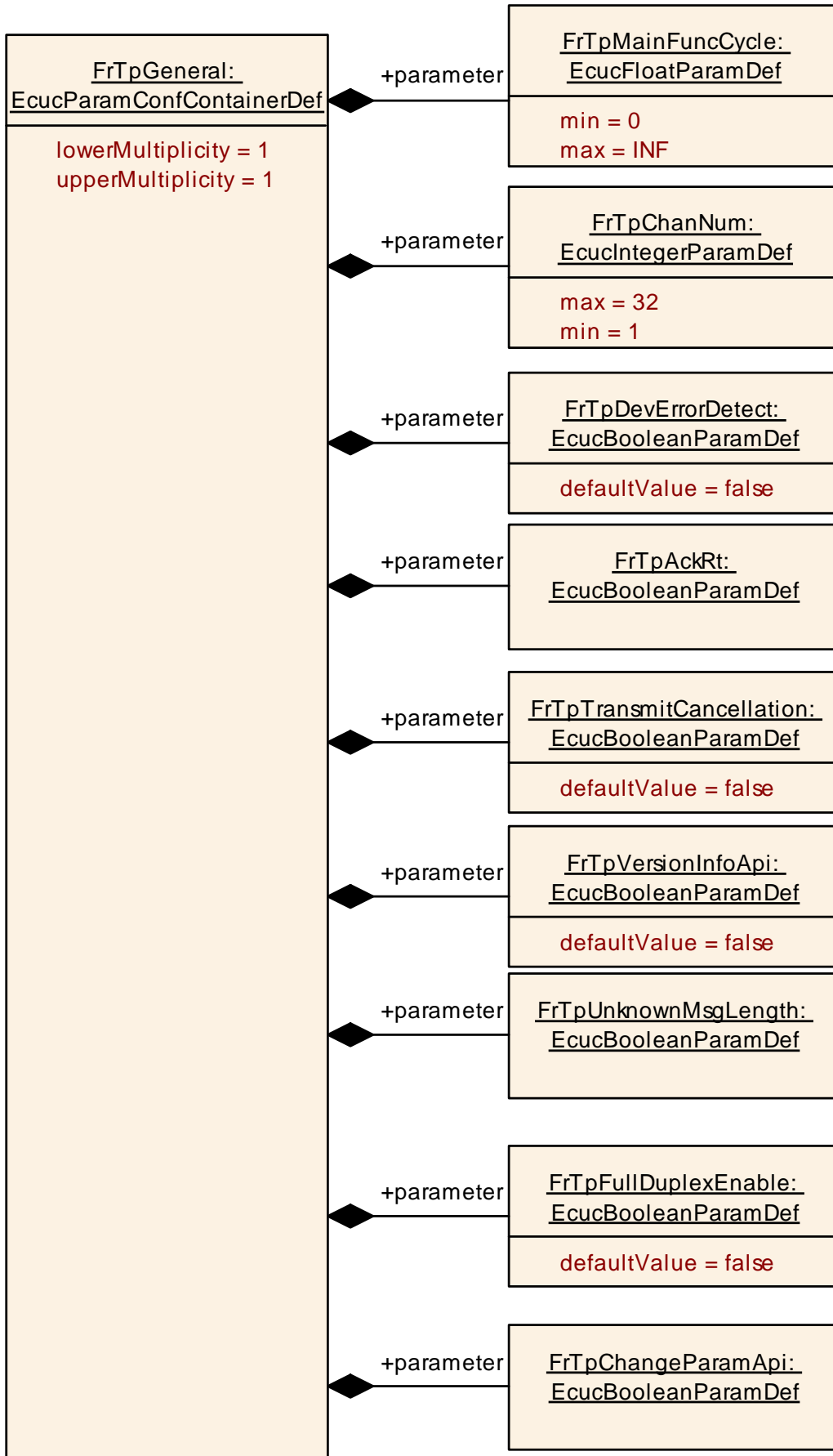

### 10.2.3 FrTpMultipleConfig

<b>SWS Item</b>	[ECUC_FrTp_00018]
<b>Container Name</b>	FrTpMultipleConfig
<b>Parent Container</b>	FrTp
<b>Description</b>	This container contains the configuration parameters and sub containers of the AUTOSAR FrTp module.
<b>Configuration Parameters</b>	

<b>SWS Item</b>	[ECUC_FrTp_00054]		
<b>Parameter Name</b>	FrTpMaxConnectionCnt		
<b>Parent Container</b>	FrTpMultipleConfig		
<b>Description</b>	Maximum number of TP connections. This parameter is needed only in case of post-build loadable implementation using static memory allocation.		
<b>Multiplicity</b>	0..1		
<b>Type</b>	EcucIntegerParamDef		
<b>Range</b>	0 .. 18446744073709551615		
<b>Default value</b>	--		
<b>Post-Build Variant Multiplicity</b>	false		
<b>Post-Build Variant Value</b>	false		
<b>Multiplicity Configuration Class</b>	<b>Pre-compile time</b>	X	All Variants
	<b>Link time</b>	--	
	<b>Post-build time</b>	--	
<b>Value Configuration Class</b>	<b>Pre-compile time</b>	X	All Variants
	<b>Link time</b>	--	
	<b>Post-build time</b>	--	
<b>Scope / Dependency</b>	scope: local		

<b>Included Containers</b>
----------------------------

Container Name	Multiplicity	Scope / Dependency
FrTpConnection	1..*	This container contains the connection specific parameters to transfer N-PDUs via FlexRay TP.
FrTpConnection-Control	1..*	This container contains the configuration parameters to control a FlexRay TP connection.
FrTpRxPduPool	0..*	This container contains all Pdus that are assigned to that Pdu Pool.
FrTpTxPduPool	0..*	This container contains all Pdus that are assigned to that Pdu Pool.

## 10.2.4 FrTpConnection

<b>SWS Item</b>	[ECUC_FrTp_00006]		
<b>Container Name</b>	FrTpConnection		
<b>Parent Container</b>	FrTpMultipleConfig		
<b>Description</b>	This container contains the connection specific parameters to transfer N-PDUs via FlexRay TP.		
<b>Post-Build Variant Multiplicity</b>	true		
<b>Multiplicity Configuration Class</b>	<b>Pre-compile time</b>	X	VARIANT-PRE-COMPILE
	<b>Link time</b>	--	
	<b>Post-build time</b>	X	VARIANT-POST-BUILD
<b>Configuration Parameters</b>			

<b>SWS Item</b>	[ECUC_FrTp_00050]
<b>Parameter Name</b>	FrTpBandwidthLimitation
<b>Parent Container</b>	FrTpConnection
<b>Description</b>	This parameter indicates whether the connection requires a bandwidth limitation or not. If FrTpBandwidthLimitation=True the sender shall send a StartFrame always on the first PDU of a PDU-Pool.
<b>Multiplicity</b>	1
<b>Type</b>	EcucBooleanParamDef
<b>Default value</b>	--
<b>Post-Build</b>	true

<b>Variant Value</b>			
<b>Value Configuration Class</b>	<b>Pre-compile time</b>	X	VARIANT-PRE-COMPILE
	<b>Link time</b>	--	
	<b>Post-build time</b>	X	VARIANT-POST-BUILD
<b>Scope / Dependency</b>	scope: local		

<b>SWS Item</b>	[ECUC_FrTp_00010]		
<b>Parameter Name</b>	FrTpLa		
<b>Parent Container</b>	FrTpConnection		
<b>Description</b>	This parameter defines the Local Address for the respective connection. When the local instance is the sender, this is the Source Address within the TP frame. When the local instance is the receiver, this is the Target Address within the TP frame. If this parameter is not configured, all related Rx N-SDUs must be configured to use the meta data item TARGET_ADDRESS_16, and all related Tx-N-SDUs must be configured to use the meta data item SOURCE_ADDRESS_16.		
<b>Multiplicity</b>	0..1		
<b>Type</b>	EcucIntegerParamDef		
<b>Range</b>	0 .. 65535		
<b>Default value</b>	--		
<b>Post-Build Variant Value</b>	true		
<b>Value Configuration Class</b>	<b>Pre-compile time</b>	X	VARIANT-PRE-COMPILE
	<b>Link time</b>	--	
	<b>Post-build time</b>	X	VARIANT-POST-BUILD
<b>Scope / Dependency</b>	scope: local		

<b>SWS Item</b>	[ECUC_FrTp_00019]		
<b>Parameter Name</b>	FrTpMultipleReceiverCon		
<b>Parent Container</b>	FrTpConnection		
<b>Description</b>	This parameter defines, whether this connection is an 1:1 ('false') or an 1:n ('true') connection. If data segmentation is required this parameter is used to check whether segmentation is possible or not. If the connection is 1:n segmentation is not possible and an error will occur.		

<b>Multiplicity</b>	1		
<b>Type</b>	EcucBooleanParamDef		
<b>Default value</b>	--		
<b>Post-Build Variant Value</b>	true		
<b>Value Configuration Class</b>	<b>Pre-compile time</b>	X	VARIANT-PRE-COMPILE
	<b>Link time</b>	--	
	<b>Post-build time</b>	X	VARIANT-POST-BUILD
<b>Scope / Dependency</b>	scope: local		

<b>SWS Item</b>	[ECUC_FrTp_00021]		
<b>Parameter Name</b>	FrTpRa		
<b>Parent Container</b>	FrTpConnection		
<b>Description</b>	This parameter defines the Remote Address for the respective connection. When the local instance is the sender, this is the Target Address within the TP frame. When the local instance is the receiver, this is the Source Address within the TP frame. If this parameter is not configured, all related Rx N-SDUs must be configured to use the meta data item SOURCE_ADDRESS_16, and all related Tx-N-SDUs must be configured to use the meta data item TARGET_ADDRESS_16.		
<b>Multiplicity</b>	0..1		
<b>Type</b>	EcucIntegerParamDef		
<b>Range</b>	0 .. 65535		
<b>Default value</b>	--		
<b>Post-Build Variant Value</b>	true		
<b>Value Configuration Class</b>	<b>Pre-compile time</b>	X	VARIANT-PRE-COMPILE
	<b>Link time</b>	--	
	<b>Post-build time</b>	X	VARIANT-POST-BUILD
<b>Scope / Dependency</b>	scope: local		

<b>SWS Item</b>	[ECUC_FrTp_00005]		
<b>Parameter Name</b>	FrTpConCtrlRef		

<b>Parent Container</b>	FrTpConnection		
<b>Description</b>	FrTpConnectionControlReference: This parameter defines a reference to a connection control container.		
<b>Multiplicity</b>	1		
<b>Type</b>	Reference to FrTpConnectionControl		
<b>Post-Build Variant Value</b>	true		
<b>Value Configuration Class</b>	<b>Pre-compile time</b>	X	VARIANT-PRE-COMPILE
	<b>Link time</b>	--	
	<b>Post-build time</b>	X	VARIANT-POST-BUILD
<b>Scope / Dependency</b>	scope: local		

<b>SWS Item</b>	[ECUC_FrTp_00025]		
<b>Parameter Name</b>	FrTpRxPduPoolRef		
<b>Parent Container</b>	FrTpConnection		
<b>Description</b>	This parameter defines a reference to a RxPduPool.		
<b>Multiplicity</b>	0..1		
<b>Type</b>	Reference to FrTpRxPduPool		
<b>Post-Build Variant Multiplicity</b>	true		
<b>Post-Build Variant Value</b>	true		
<b>Multiplicity Configuration Class</b>	<b>Pre-compile time</b>	X	VARIANT-PRE-COMPILE
	<b>Link time</b>	--	
	<b>Post-build time</b>	X	VARIANT-POST-BUILD
<b>Value Configuration Class</b>	<b>Pre-compile time</b>	X	VARIANT-PRE-COMPILE
	<b>Link time</b>	--	
	<b>Post-build time</b>	X	VARIANT-POST-BUILD
<b>Scope / Dependency</b>	scope: local		

<b>SWS Item</b>	[ECUC_FrTp_00039]		
<b>Parameter Name</b>	FrTpTxPduPoolRef		
<b>Parent Container</b>	FrTpConnection		
<b>Description</b>	This parameter defines a reference to a TxPduPool.		
<b>Multiplicity</b>	0..1		



<b>Type</b>	Reference to FrTpTxPduPool		
<b>Post-Build Variant Multiplicity</b>	true		
<b>Post-Build Variant Value</b>	true		
<b>Multiplicity Configuration Class</b>	<b>Pre-compile time</b>	X	VARIANT-PRE-COMPILE
	<b>Link time</b>	--	
	<b>Post-build time</b>	X	VARIANT-POST-BUILD
<b>Value Configuration Class</b>	<b>Pre-compile time</b>	X	VARIANT-PRE-COMPILE
	<b>Link time</b>	--	
	<b>Post-build time</b>	X	VARIANT-POST-BUILD
<b>Scope / Dependency</b>	scope: local		

<b>Included Containers</b>		
<b>Container Name</b>	<b>Multiplicity</b>	<b>Scope / Dependency</b>
FrTpRxSdu	0..1	This parameter defines the Rx Service Data Unit Identifier (Sdu Id) which uniquely identifies a data transfer (inter-module communication) between FrTp and PDUR. This N-SDU can produce meta data items of type SOURCE_ADDRESS_16 and TARGET_ADDRESS_16.
FrTpTxSdu	0..1	This parameter defines the Tx Service Data Unit Identifier (Sdu Id) which uniquely identifies a data transfer (inter-module communication) between FrTp and PDUR. This N-SDU can consume meta data items of type SOURCE_ADDRESS_16 and TARGET_ADDRESS_16.

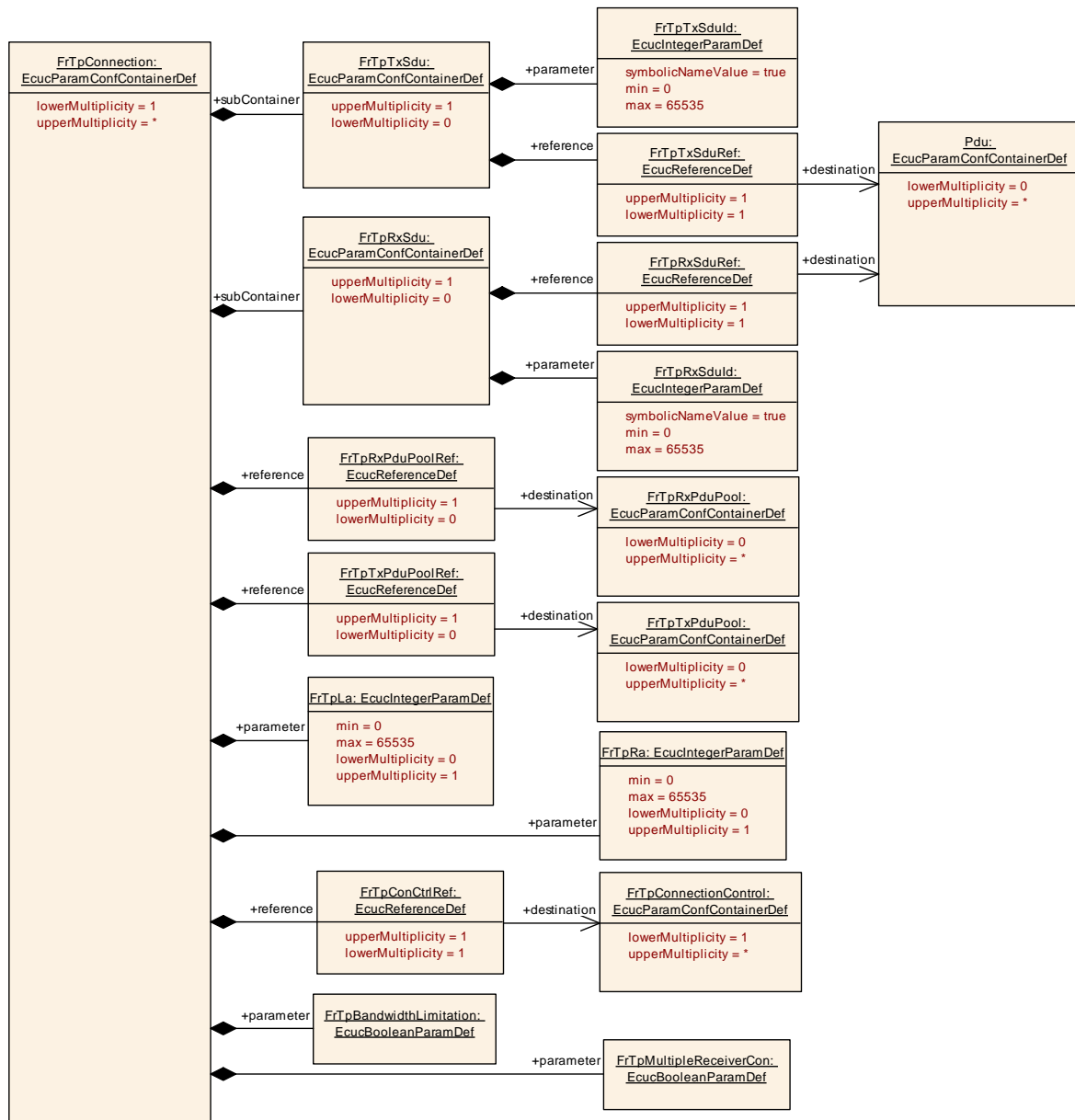

### 10.2.5 FrTpTxSdu

<b>SWS Item</b>	[ECUC_FrTp_00041]
<b>Container Name</b>	FrTpTxSdu
<b>Parent Container</b>	FrTpConnection
<b>Description</b>	This parameter defines the Tx Service Data Unit Identifier (Sdu Id) which uniquely identifies a data transfer (inter-module communication) between FrTp and PDUR. This N-SDU can consume meta data items of type SOURCE_ADDRESS_16 and TARGET_ADDRESS_16.

<b>Configuration Parameters</b>
---------------------------------

<b>SWS Item</b>	[ECUC_FrTp_00042]		
<b>Parameter Name</b>	FrTpTxSduId		
<b>Parent Container</b>	FrTpTxSdu		
<b>Description</b>	This is a unique identifier for a to be transmitted message from the PduR to the FrTp. ImplementationType: PduldType		
<b>Multiplicity</b>	1		
<b>Type</b>	EcucIntegerParamDef (Symbolic Name generated for this parameter)		
<b>Range</b>	0 .. 65535		
<b>Default value</b>	--		
<b>Post-Build Variant Value</b>	false		
<b>Value Configuration Class</b>	<b>Pre-compile time</b>	X	All Variants
	<b>Link time</b>	--	
	<b>Post-build time</b>	--	
<b>Scope / Dependency</b>	scope: local		

<b>SWS Item</b>	[ECUC_FrTp_00043]		
<b>Parameter Name</b>	FrTpTxSduRef		
<b>Parent Container</b>	FrTpTxSdu		
<b>Description</b>	Reference to a PDU in the global PDU structure.		
<b>Multiplicity</b>	1		
<b>Type</b>	Reference to Pdu		
<b>Post-Build Variant Value</b>	true		
<b>Value Configuration Class</b>	<b>Pre-compile time</b>	X	VARIANT-PRE-COMPILE
	<b>Link time</b>	--	
	<b>Post-build time</b>	X	VARIANT-POST-BUILD
<b>Scope / Dependency</b>			

<b>No Included Containers</b>
-------------------------------

## 10.2.6 FrTpRxSdu

<b>SWS Item</b>	[ECUC_FrTp_00027]
<b>Container Name</b>	FrTpRxSdu
<b>Parent Container</b>	FrTpConnection
<b>Description</b>	This parameter defines the Rx Service Data Unit Identifier (Sdu Id) which uniquely identifies a data transfer (inter-module communication) between FrTp and PDUR. This N-SDU can produce meta data items of type SOURCE_ADDRESS_16 and TARGET_ADDRESS_16.
<b>Configuration Parameters</b>	

<b>SWS Item</b>	[ECUC_FrTp_00053]		
<b>Parameter Name</b>	FrTpRxSdulD		
<b>Parent Container</b>	FrTpRxSdu		
<b>Description</b>	This unique identifier is used for change parameter request or receive cancellation from PduR to FrTp. ImplementationType: PdulDType		
<b>Multiplicity</b>	1		
<b>Type</b>	EcucIntegerParamDef (Symbolic Name generated for this parameter)		
<b>Range</b>	0 .. 65535		
<b>Default value</b>	--		
<b>Post-Build Variant Value</b>	false		
<b>Value Configuration Class</b>	<b>Pre-compile time</b>	X	All Variants
	<b>Link time</b>	--	
	<b>Post-build time</b>	--	
<b>Scope / Dependency</b>	scope: local		

<b>SWS Item</b>	[ECUC_FrTp_00028]
<b>Parameter Name</b>	FrTpRxSduRef
<b>Parent Container</b>	FrTpRxSdu
<b>Description</b>	Reference to a PDU in the global PDU structure.
<b>Multiplicity</b>	1
<b>Type</b>	Reference to Pdu

<b>Post-Build Variant Value</b>	true		
<b>Value Configuration Class</b>	<b>Pre-compile time</b>	X	VARIANT-PRE-COMPILE
	<b>Link time</b>	--	
	<b>Post-build time</b>	X	VARIANT-POST-BUILD
<b>Scope / Dependency</b>			

<b>No Included Containers</b>
-------------------------------

### 10.2.7 FrTpConnectionControl

<b>SWS Item</b>	[ECUC_FrTp_00007]		
<b>Container Name</b>	FrTpConnectionControl		
<b>Parent Container</b>	FrTpMultipleConfig		
<b>Description</b>	This container contains the configuration parameters to control a Flex Ray TP connection.		
<b>Post-Build Variant Multiplicity</b>	true		
<b>Multiplicity Configuration Class</b>	<b>Pre-compile time</b>	X	VARIANT-PRE-COMPILE
	<b>Link time</b>	--	
	<b>Post-build time</b>	X	VARIANT-POST-BUILD
<b>Configuration Parameters</b>			

<b>SWS Item</b>	[ECUC_FrTp_00003]		
<b>Parameter Name</b>	FrTpAckType		
<b>Parent Container</b>	FrTpConnectionControl		
<b>Description</b>	This parameter defines the type of acknowledgement which is used for the specific channel.		
<b>Multiplicity</b>	1		
<b>Type</b>	EcucEnumerationParamDef		
<b>Range</b>	FRTP_ACK_WITH_RT	Acknowledgement with retry	
	FRTP_NO	No acknowledgement	
<b>Post-Build Variant</b>	true		

<b>Value</b>			
<b>Value Configuration Class</b>	<b>Pre-compile time</b>	X	VARIANT-PRE-COMPILE
	<b>Link time</b>	--	
	<b>Post-build time</b>	X	VARIANT-POST-BUILD
<b>Scope / Dependency</b>	scope: local		

<b>SWS Item</b>	[ECUC_FrTp_00014]		
<b>Parameter Name</b>	FrTpMaxFCWait		
<b>Parent Container</b>	FrTpConnectionControl		
<b>Description</b>	This parameter defines the maximum number of FlowControl N-PDUs with FlowState "WAIT"		
<b>Multiplicity</b>	1		
<b>Type</b>	EcucIntegerParamDef		
<b>Range</b>	0 .. 255		
<b>Default value</b>	--		
<b>Post-Build Variant Value</b>	true		
<b>Value Configuration Class</b>	<b>Pre-compile time</b>	X	VARIANT-PRE-COMPILE
	<b>Link time</b>	--	
	<b>Post-build time</b>	X	VARIANT-POST-BUILD
<b>Scope / Dependency</b>	scope: local		

<b>SWS Item</b>	[ECUC_FrTp_00029]		
<b>Parameter Name</b>	FrTpMaxNbrOfNPduPerCycle		
<b>Parent Container</b>	FrTpConnectionControl		
<b>Description</b>	This parameter is part of the ISO 10681-2 protocol's FlowControl parameter "Bandwidth Control (BC)". It limits the number of N-Pdus the sender is allowed to transmit within a FlexRay cycle.		
<b>Multiplicity</b>	1		
<b>Type</b>	EcucIntegerParamDef		
<b>Range</b>	0 .. 31		
<b>Default value</b>	--		
<b>Post-Build Variant Value</b>	true		

<b>Value Configuration Class</b>	<b>Pre-compile time</b>	X	VARIANT-PRE-COMPILE
	<b>Link time</b>	--	
	<b>Post-build time</b>	X	VARIANT-POST-BUILD
<b>Scope / Dependency</b>	scope: local		

<b>SWS Item</b>	[ECUC_FrTp_00017]		
<b>Parameter Name</b>	FrTpMaxRn		
<b>Parent Container</b>	FrTpConnectionControl		
<b>Description</b>	This parameter defines the maximum number of retries (if retry is configured).		
<b>Multiplicity</b>	1		
<b>Type</b>	EcucIntegerParamDef		
<b>Range</b>	0 .. 255		
<b>Default value</b>	--		
<b>Post-Build Variant Value</b>	true		
<b>Value Configuration Class</b>	<b>Pre-compile time</b>	X	VARIANT-PRE-COMPILE
	<b>Link time</b>	--	
	<b>Post-build time</b>	X	VARIANT-POST-BUILD
<b>Scope / Dependency</b>	scope: local		

<b>SWS Item</b>	[ECUC_FrTp_00020]		
<b>Parameter Name</b>	FrTpSCexp		
<b>Parent Container</b>	FrTpConnectionControl		
<b>Description</b>	This parameter is part of the ISO 10681-2 protocol's FlowControl parameter "Bandwidth Control (BC)". It represents the exponent to calculate the minimum number of "Separation Cycles" the sender has to wait for the next transmission of an FrTp N-Pdu.		
<b>Multiplicity</b>	1		
<b>Type</b>	EcucIntegerParamDef		
<b>Range</b>	0 .. 7		
<b>Default value</b>	--		
<b>Post-Build Variant Value</b>	true		

<b>Value Configuration Class</b>	<b>Pre-compile time</b>	X	VARIANT-PRE-COMPILE
	<b>Link time</b>	--	
	<b>Post-build time</b>	X	VARIANT-POST-BUILD
<b>Scope / Dependency</b>	scope: local		

<b>SWS Item</b>	[ECUC_FrTp_00047]		
<b>Parameter Name</b>	FrTpTimeBr		
<b>Parent Container</b>	FrTpConnectionControl		
<b>Description</b>	This parameter defines the time in seconds the FrTp requires to transmit a corresponding FlowControl Frame. According to ISO 10681-2 this parameter is a performance requirement.		
<b>Multiplicity</b>	1		
<b>Type</b>	EcucFloatParamDef		
<b>Range</b>	[0 .. 0.255]		
<b>Default value</b>	--		
<b>Post-Build Variant Value</b>	true		
<b>Value Configuration Class</b>	<b>Pre-compile time</b>	X	VARIANT-PRE-COMPILE
	<b>Link time</b>	--	
	<b>Post-build time</b>	X	VARIANT-POST-BUILD
<b>Scope / Dependency</b>	scope: local		

<b>SWS Item</b>	[ECUC_FrTp_00056]		
<b>Parameter Name</b>	FrTpTimeCs		
<b>Parent Container</b>	FrTpConnectionControl		
<b>Description</b>	This parameter defines the time in seconds between the sending of two CFs or between the sending of a CF and LF or between the reception of a FC and sending of the next CF.		
<b>Multiplicity</b>	1		
<b>Type</b>	EcucFloatParamDef		
<b>Range</b>	[0 .. 65.535]		
<b>Default value</b>	--		
<b>Post-Build</b>	true		



<b>Variant Value</b>			
<b>Value Configuration Class</b>	<b>Pre-compile time</b>	X	VARIANT-PRE-COMPILE
	<b>Link time</b>	--	
	<b>Post-build time</b>	X	VARIANT-POST-BUILD
<b>Scope / Dependency</b>	scope: local		

<b>SWS Item</b>	[ECUC_FrTp_00032]		
<b>Parameter Name</b>	FrTpTimeoutAr		
<b>Parent Container</b>	FrTpConnectionControl		
<b>Description</b>	This parameter states the timeout in seconds between the PDU transmit request of the Transport Layer to the FlexRay Interface and the corresponding confirmation of the FlexRay Interface on the receiver side (for FC or AF).		
<b>Multiplicity</b>	1		
<b>Type</b>	EcucFloatParamDef		
<b>Range</b>	[0 .. 65.535]		
<b>Default value</b>	--		
<b>Post-Build Variant Value</b>	true		
<b>Value Configuration Class</b>	<b>Pre-compile time</b>	X	VARIANT-PRE-COMPILE
	<b>Link time</b>	--	
	<b>Post-build time</b>	X	VARIANT-POST-BUILD
<b>Scope / Dependency</b>	scope: local dependency: It is obvious that $FRTP\_TIME\_BR + FRTP\_TIMEOUT\_AR < FRTP\_TIMEOUT\_BS$ must hold (because the transmission duration on the bus has also to be considered).		

<b>SWS Item</b>	[ECUC_FrTp_00033]		
<b>Parameter Name</b>	FrTpTimeoutAs		
<b>Parent Container</b>	FrTpConnectionControl		
<b>Description</b>	This parameter specifies the timeout in seconds the FrIf shall confirm a transmitted Pdu to the FrTp.		
<b>Multiplicity</b>	1		
<b>Type</b>	EcucFloatParamDef		
<b>Range</b>	[0 .. 65.535]		

<b>Default value</b>	--		
<b>Post-Build Variant Value</b>	true		
<b>Value Configuration Class</b>	<b>Pre-compile time</b>	X	VARIANT-PRE-COMPILE
	<b>Link time</b>	--	
	<b>Post-build time</b>	X	VARIANT-POST-BUILD
<b>Scope / Dependency</b>	scope: local dependency: It is obvious that $FRTP\_TIME\_CS + FRTP\_TIMEOUT\_AS < FRTP\_TIMEOUT\_CR$ must hold (because the transmission duration on the bus has also to be considered).		

<b>SWS Item</b>	[ECUC_FrTp_00034]		
<b>Parameter Name</b>	FrTpTimeoutBs		
<b>Parent Container</b>	FrTpConnectionControl		
<b>Description</b>	This parameter defines the timeout in seconds for waiting for an FC or AF on the sender side in a 1:1 connection.		
<b>Multiplicity</b>	1		
<b>Type</b>	EcucFloatParamDef		
<b>Range</b>	[0 .. 65.535]		
<b>Default value</b>	--		
<b>Post-Build Variant Value</b>	true		
<b>Value Configuration Class</b>	<b>Pre-compile time</b>	X	VARIANT-PRE-COMPILE
	<b>Link time</b>	--	
	<b>Post-build time</b>	X	VARIANT-POST-BUILD
<b>Scope / Dependency</b>	scope: local dependency: It is obvious that $FRTP\_TIME\_BR + FRTP\_TIMEOUT\_AR < FRTP\_TIMEOUT\_BS$ must hold (because the transmission duration on the bus has also to be considered).		

<b>SWS Item</b>	[ECUC_FrTp_00035]		
<b>Parameter Name</b>	FrTpTimeoutCr		
<b>Parent Container</b>	FrTpConnectionControl		
<b>Description</b>	This parameter defines the timeout value in seconds a receiver is waiting for a CF or a LF.		
<b>Multiplicity</b>	1		

<b>Type</b>	EcucFloatParamDef		
<b>Range</b>	[0 .. 65.535]		
<b>Default value</b>	--		
<b>Post-Build Variant Value</b>	true		
<b>Value Configuration Class</b>	<b>Pre-compile time</b>	X	VARIANT-PRE-COMPILE
	<b>Link time</b>	--	
	<b>Post-build time</b>	X	VARIANT-POST-BUILD
<b>Scope / Dependency</b>	scope: local dependency: It is obvious that FRTP_TIME_CS + FRTP_TIMEOUT_AS < FRTP_TIMEOUT_CR must hold (because the transmission duration on the bus has also to be considered).		

**No Included Containers**

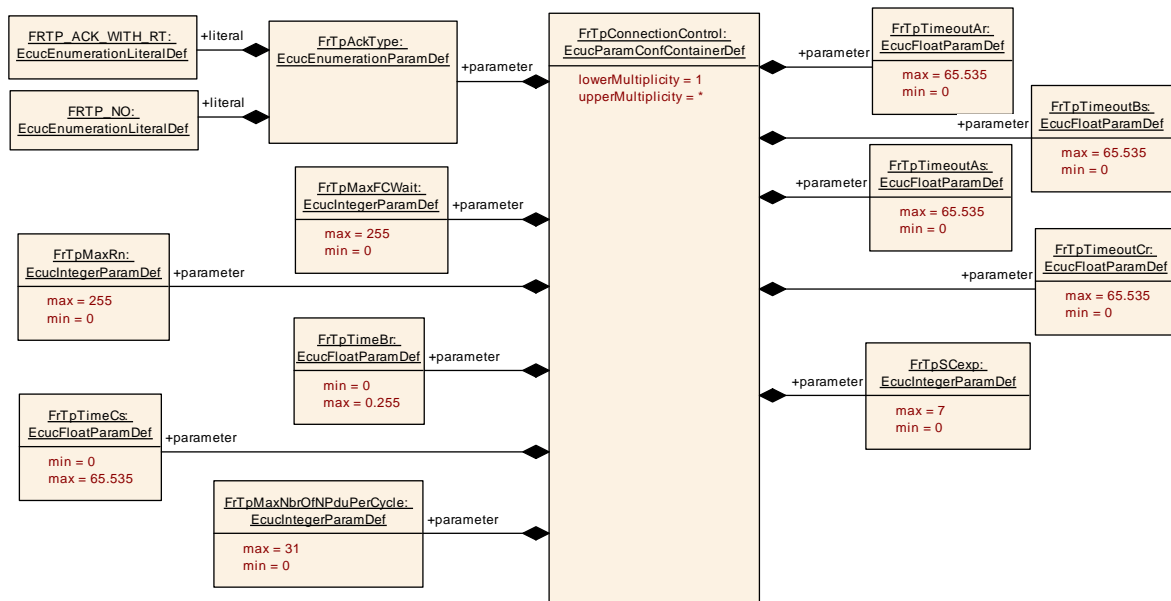

### 10.2.8 FrTpTxPduPool

<b>SWS Item</b>	[ECUC_FrTp_00038]
<b>Container Name</b>	FrTpTxPduPool
<b>Parent Container</b>	FrTpMultipleConfig
<b>Description</b>	This container contains all Pdus that are assigned to that Pdu Pool.

<b>Post-Build Variant Multiplicity</b>	true		
<b>Multiplicity Configuration Class</b>	<b>Pre-compile time</b>	X	VARIANT-PRE-COMPILE
	<b>Link time</b>	--	
	<b>Post-build time</b>	X	VARIANT-POST-BUILD
<b>Configuration Parameters</b>			

<b>Included Containers</b>		
<b>Container Name</b>	<b>Multiplicity</b>	<b>Scope / Dependency</b>
FrTpTxPdu	1..*	Container to hold the PDU parameters. ImplementationType: PduInfoType

### 10.2.9 FrTpRxPduPool

<b>SWS Item</b>	[ECUC_FrTp_00024]		
<b>Container Name</b>	FrTpRxPduPool		
<b>Parent Container</b>	FrTpMultipleConfig		
<b>Description</b>	This container contains all Pdus that are assigned to that Pdu Pool.		
<b>Post-Build Variant Multiplicity</b>	true		
<b>Multiplicity Configuration Class</b>	<b>Pre-compile time</b>	X	VARIANT-PRE-COMPILE
	<b>Link time</b>	--	
	<b>Post-build time</b>	X	VARIANT-POST-BUILD
<b>Configuration Parameters</b>			

<b>Included Containers</b>		
<b>Container Name</b>	<b>Multiplicity</b>	<b>Scope / Dependency</b>
FrTpRxPdu	1..*	Container to hold the PDU parameters. ImplementationType: PduInfoType

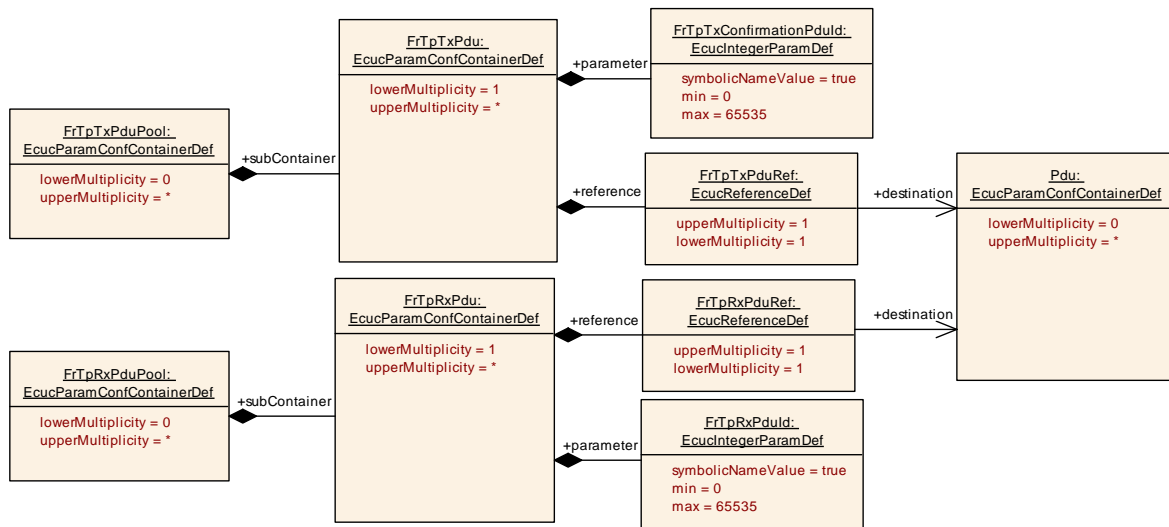

### 10.2.10 FrTpTxPdu

<b>SWS Item</b>	[ECUC_FrTp_00037]		
<b>Container Name</b>	FrTpTxPdu		
<b>Parent Container</b>	FrTpTxPduPool		
<b>Description</b>	Container to hold the PDU parameters. ImplementationType: PduInfoType		
<b>Post-Build Variant Multiplicity</b>	true		
<b>Multiplicity Configuration Class</b>	<b>Pre-compile time</b>	X	VARIANT-PRE-COMPILE
	<b>Link time</b>	--	
	<b>Post-build time</b>	X	VARIANT-POST-BUILD
<b>Configuration Parameters</b>			

<b>SWS Item</b>	[ECUC_FrTp_00049]
<b>Parameter Name</b>	FrTpTxConfirmationPduld
<b>Parent Container</b>	FrTpTxPdu
<b>Description</b>	Handle Id to be used by the FrIf to confirm the transmission of the FrTpTxPdu to the FrIf module (FrTp_TxConfirmation) and for TriggerTransmit (FrTp_TriggerTransmit).
<b>Multiplicity</b>	1
<b>Type</b>	EcucIntegerParamDef (Symbolic Name generated for this parameter)
<b>Range</b>	0 .. 65535

<b>Default value</b>	--		
<b>Post-Build Variant Value</b>	false		
<b>Value Configuration Class</b>	<b>Pre-compile time</b>	X	All Variants
	<b>Link time</b>	--	
	<b>Post-build time</b>	--	
<b>Scope / Dependency</b>	scope: local		

<b>SWS Item</b>	[ECUC_FrTp_00040]		
<b>Parameter Name</b>	FrTpTxPduRef		
<b>Parent Container</b>	FrTpTxPdu		
<b>Description</b>	Reference to a PDU in the global PDU structure.		
<b>Multiplicity</b>	1		
<b>Type</b>	Reference to Pdu		
<b>Post-Build Variant Value</b>	true		
<b>Value Configuration Class</b>	<b>Pre-compile time</b>	X	VARIANT-PRE-COMPILE
	<b>Link time</b>	--	
	<b>Post-build time</b>	X	VARIANT-POST-BUILD
<b>Scope / Dependency</b>	scope: local		

No Included Containers

### 10.2.11 FrTpRxPdu

<b>SWS Item</b>	[ECUC_FrTp_00022]		
<b>Container Name</b>	FrTpRxPdu		
<b>Parent Container</b>	FrTpRxPduPool		
<b>Description</b>	Container to hold the PDU parameters. ImplementationType: PduInfoType		
<b>Post-Build Variant Multiplicity</b>	true		
<b>Multiplicity Configuration Class</b>	<b>Pre-compile time</b>	X	VARIANT-PRE-COMPILE
	<b>Link time</b>	--	

	<b>Post-build time</b>	X	VARIANT-POST-BUILD
<b>Configuration Parameters</b>			

<b>SWS Item</b>	[ECUC_FrTp_00023]		
<b>Parameter Name</b>	FrTpRxPduld		
<b>Parent Container</b>	FrTpRxPdu		
<b>Description</b>	This is a unique identifier for a received message which is forwarded from the Frlf to the FrTp. ImplementationType: PduldType		
<b>Multiplicity</b>	1		
<b>Type</b>	EcucIntegerParamDef (Symbolic Name generated for this parameter)		
<b>Range</b>	0 .. 65535		
<b>Default value</b>	--		
<b>Post-Build Variant Value</b>	false		
<b>Value Configuration Class</b>	<b>Pre-compile time</b>	X	All Variants
	<b>Link time</b>	--	
	<b>Post-build time</b>	--	
<b>Scope / Dependency</b>	scope: local		

<b>SWS Item</b>	[ECUC_FrTp_00026]		
<b>Parameter Name</b>	FrTpRxPduRef		
<b>Parent Container</b>	FrTpRxPdu		
<b>Description</b>	Reference to a PDU in the global PDU structure.		
<b>Multiplicity</b>	1		
<b>Type</b>	Reference to Pdu		
<b>Post-Build Variant Value</b>	true		
<b>Value Configuration Class</b>	<b>Pre-compile time</b>	X	VARIANT-PRE-COMPILE
	<b>Link time</b>	--	
	<b>Post-build time</b>	X	VARIANT-POST-BUILD
<b>Scope / Dependency</b>			

<b>No Included Containers</b>
-------------------------------





### 10.3 Published Information

For details refer to the chapter 10.3 “Published Information” in SWS\_BSWGeneral.

### 10.4 Configuration dependencies and recommendation

The FrTp module functionality is based on several configuration parameters. To guarantee a well working software module this chapter gives some recommendation to the configuration parameter set. These rules shall be part of consistency checks of configuration tools.

#### 10.4.1 Retry behaviour

The term of retry is used several times within this document but always with different focus. As depict in Figure 27 the FrTp module has basically two different retry behaviours:

- a) Multiple API calls in case of an error or a busy system
- b) Retry of PDU transfer depending on transport protocol conditions.

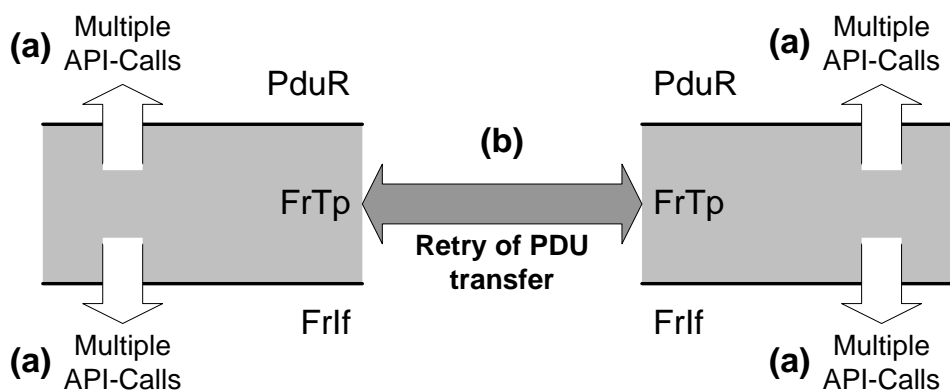

Figure 27: FrTp Retry Scenarios

Only for case (b) Retry of PDU transfer a global switch for enabling and disabling is defined (FrTpAckType). All other cases depend on the configuration of the different counters for the API calls: FRTP\_MAX\_FCWAIT, FRTP\_MAX\_AR.

#### 10.4.2 TP-Acknowledgement and Retry

Acknowledgement and retry is only possible on 1:1 connections because the communication nodes have to deal with the FlowControl N-PDU parameters. FlowControl is not allowed for 1:n connections.

**[SWS\_FrTp\_00598]** [If configuration parameter *FrTpMultipleReceiverCon* is set for a connection, no Acknowledgement and retry shall be supported irrespective whether the configuration parameter *FrTpAckType* is set or not.]()

### 10.4.3 Timing and Timeout Parameters

Timing and timeout behaviour depends on the global FlexRay schedule. To guarantee a stable system some timing and timeout relations shall be taken into account. The timeout behaviour is defined in chapter 7.5.8.

→ *Hinweise Configurationshinweis*

**[SWS\_FrTp\_01154]**      「For timeout As configuration it shall be considered that  
 $\text{FRTP\_TIMEOUT\_AS} > \text{FRTP\_TIME\_AS} \rfloor ()$

**[SWS\_FrTp\_01155]**      「For timeout Ar configuration it shall be considered that  
 $\text{FRTP\_TIMEOUT\_AR} > \text{FRTP\_TIME\_AR} \rfloor ()$

**[SWS\_FrTp\_00599]**      「For timeout Bs configuration it shall be considered that  
 $\text{FRTP\_TIMEOUT\_BS} > \text{FRTP\_TIME\_BR} + \text{FRTP\_TIME\_AR} \rfloor ()$

**[SWS\_FrTp\_01153]**      「For timeout Cr configuration it shall be considered that  
 $\text{FRTP\_TIMEOUT\_CR} > \text{FRTP\_TIME\_CS} + \text{FRTP\_TIME\_AS} \rfloor ()$

**Note:**       $\text{FRTP\_TIME\_AR}$ ,  $\text{FRTP\_TIME\_AS}$ ,  $\text{FRTP\_TIME\_BR}$  and  $\text{FRTP\_TIME\_CS}$  are performance timing values and depend on the global FlexRay schedule. To calculate that values please refer to the formulas at ISO 10681-2 [16]

**[SWS\_FrTp\_00180]**      「 The FrTp configuration shall ensure that  
 $2^{\text{SeparationCycleExponent}_-1} \times t_{\text{CycleTime}} \leq \text{FRTP\_TIMEOUT\_CR} \cdot {}^{36} \rfloor ()$

### 10.4.4 Bandwidth Control Configuration

It could occur that an ECU is not able to receive as much PDUs as defined within the PDU-Pool referenced by a connection<sup>37</sup>. In that case the bandwidth has to be limited by the receiver. There are three possibilities to limit the bandwidth for a connection link:

- a) Limit Bandwidth by Parameter FlowControl.BandwidthControl.MaxPduPerCycle in combination with Hardware FIFO buffer mechanisms.<sup>38</sup>
- b) Limit Bandwidth by Parameter FlowControl.BandwidthControl.MaxPduPerCycle to reduce the number of allowed PDUs of the currently selected PDU-Pool.
- c) Limit Bandwidth by using a dedicated PDU-Pool for the connection to the affected Ecu.

<sup>36</sup> This is to prevent a timeouts. Please refer to ISO 10681-2.

<sup>37</sup> This is possible if a Flexray Communication Controller only supports less Rx buffers and buffer reconfiguration at the end of a cycle is not possible or desired.

<sup>38</sup> This is an essential mechanism of FlexRay 3.0 protocol.

**10.4.4.1 BandwidthControl by FlowControl Parameter in combination with Hardware FIFO buffer mechanisms**

If BandwidthControl by FlowControl Parameter in combination with Hardware FIFO buffer mechanisms is used no additional configuration restrictions occur. This szenario implements “pure” ISO 10681-2 behaviour with focus on FlexRay 3.0 Hardware FIFO buffer mechanisms. The figure below shows the dependencies.

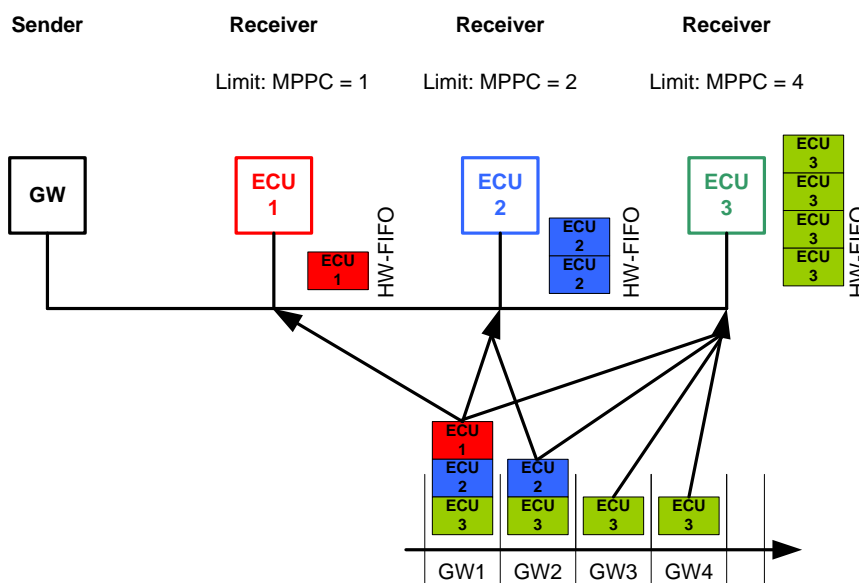

Figure 28: BandwidthControl by FlowControl Parameters in combination with HW FIFO buffer

**10.4.4.2 BandwidthControl by FlowControl Parameter**

If BandwidthControl by FlowControl Parameter is used some configuration restrictions have to be taken into account. The figure below shows the dependencies.

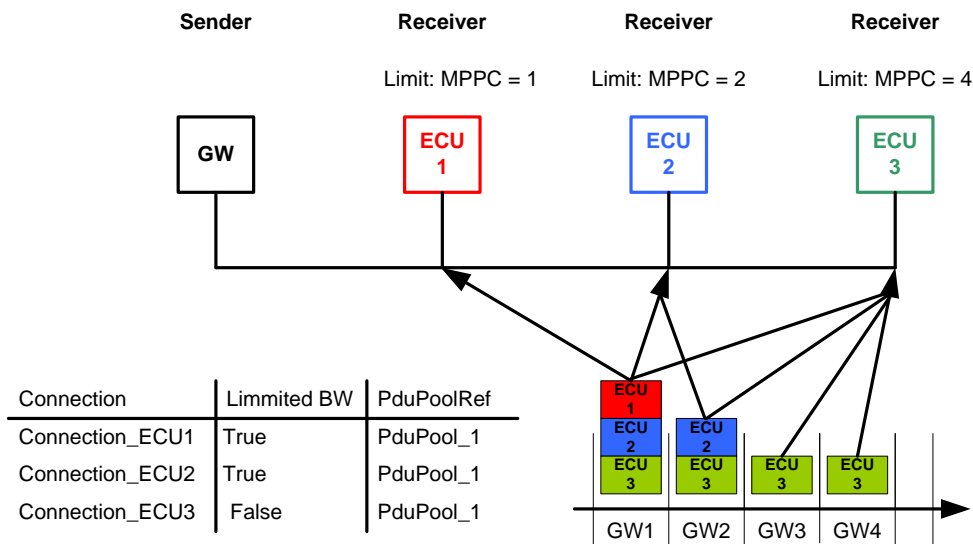

Figure 29: BandwidthControl by FlowControl Parameters

In a network four FlexRay nodes are connected. 4 PDUs are defined for the sender node. Two of the receivers have bandwidth limitations (ECU1 and ECU2).

The configuration restrictions are:

**[SWS\_FrTp\_01173]** ⌈ If bandwidth limitation in a connection to a certain ECU is realized by FlowControl parameter BC (without HW-FIFO mechanism), the attribute “FrTpBandwidthLimitation“ within the corresponding connection shall be set to „TRUE“. ⌋()

**[SWS\_FrTp\_01174]** ⌈ If bandwidth limitation is realized by FlowControl parameter BC and if the attribute “FrTpBandwidthLimitation“ is True, a Start Frame to initiate a communication link shall always be send in the first PDU of the referenced PDU-Pool. This is valid for both 1:1 and 1:n connections. ⌋()

Note: The reason for using the first frame of the pool in case of bandwidth limitation is historical.  
Bandwidth limitation is only required for FlexRay controllers with a limited number of buffers, which are then assigned to the first slots of the pool (the ones with the lowest numbers). ⌋()

**[SWS\_FrTp\_01175]** ⌈ If an ECU responds with a FlowControl-Parameter BandwidthControl.  $MPPC \neq 0$  (“zero”) the sender shall use only the number of BC.MPPC PDUs of the PDU-Pool in ascending order to transmit data within that connection. ⌋()

**[SWS\_FrTp\_01177]** ⌈ If the attribute “FrTpBandwidthLimitation“ is set to "TRUE", a Rx-connection shall use the first Pdu of the referenced Tx-Pdu-Pool for sending the required FlowControl frame to continue a communication link. ⌋()

#### 10.4.4.3 BandwidthControl via different PDU Pools

If BandwidthControl is realized by different PDU Pools two different szenarios could occur.

##### 10.4.4.3.1 BandwidthControl via non-overlapping Tx-Pdu-Pools

In case an ECU is not capable of receiving all Tx-Pdus sent for TP-communication in the FlexRay-cluster then non-overlapping Tx-Pdu-Pools can be configured as shown in the figure below:

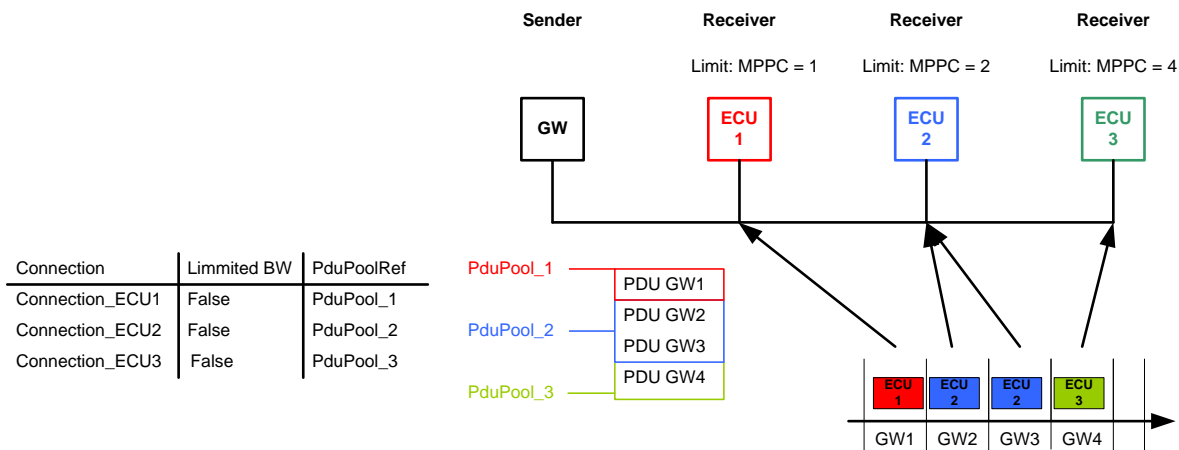

Figure 30: BandwidthControl by non-overlapping PDU Pools

**10.4.4.3.2 BandwidthControl via overlapping Tx-Pdu-Pools**

In case an Ecu is not capable of receiving all Tx-Pdus sent for TP- communication in the FlexRay-cluster then dedicated overlapping Tx-Pdu-Pools can be configured as shown in the figure below:

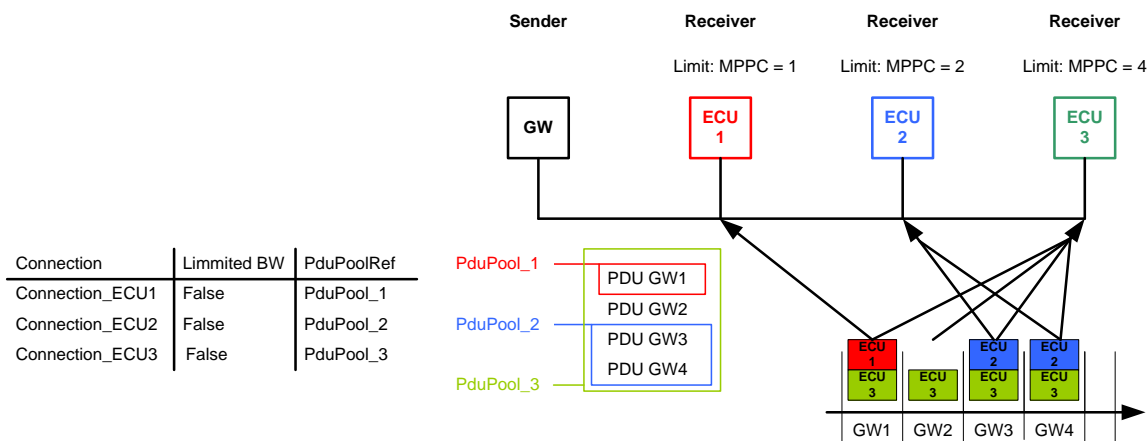

Figure 31: BandwidthControl by multiple PDU Pools

In the figure above ECU1 and ECU2 are not capable of receiving all Pdus GW1-GW4 shown above in their Rx-buffers ("Weak Ecu") and dedicated overlapping Pdu-Pools are configured and used. One Tx-Pdu can belong to more than one Tx-PDU-Pool at the same time<sup>39</sup>.

[SWS\_FrTp\_01176] 「It shall be possible to have overlapping PDU-Pools」()

<sup>39</sup> Reduced pools have to be taken into account for configuring the FlexRay-driver of "weak Ecus".

#### 10.4.5 Configuration Requirements on the FlexRay Interface

If more than one Fr N-PDU is used for one Fr N-SDU within a connection, the FrIf shall guarantee that the Fr N-PDUs (Fr L-SDUs) are scheduled (sent over the bus) in the same order the FlexRay Transport Protocol Layer uses them, i.e. in ascending order regarding the Fr N-PDU IDs used in the FlexRay Transport Protocol Layer. Furthermore these PDUs shall be scheduled with the same frequency and within one Job (concerning the Joblist) in the FlexRay Interface module (since the reading of the PDU-Available Information for all PDUs of a connection has to be atomic.) This is necessary to avoid CFs coming out of order in a segmented transfer.

For every FrTp L-SDU the PDU-Update/Valid Information of the FrIf shall be activated.

For each transmitted N-Pdu a TransmitConfirmations shall be given by the FrIf module.

For every FrTp L-SDU no FrIf Trigger Transmit counter shall be utilized, i.e. the limit of the respective counter shall be 1. This is necessary in order to avoid multiple service primitive calls of *FrTp\_TriggerTransmit* for the same Fr N-PDU in case e. g. a retry is necessary due to an timeout of the AS / AR timer.

## 11 Not applicable requirements

**[SWS\_FrTp\_NA\_09999]** 「These requirements are not applicable to this

specification.」 (SRS\_BSW\_00306, SRS\_BSW\_00312, SRS\_BSW\_00314,  
SRS\_BSW\_00323, SRS\_BSW\_00325, SRS\_BSW\_00328, SRS\_BSW\_00330,  
SRS\_BSW\_00331, SRS\_BSW\_00333, SRS\_BSW\_00335, SRS\_BSW\_00341,  
SRS\_BSW\_00343, SRS\_BSW\_00345, SRS\_BSW\_00347, SRS\_BSW\_00350,  
SRS\_BSW\_00358, SRS\_BSW\_00373, SRS\_BSW\_00375, SRS\_BSW\_00377,  
SRS\_BSW\_00386, SRS\_BSW\_00401, SRS\_BSW\_00405, SRS\_BSW\_00409,  
SRS\_BSW\_00410, SRS\_BSW\_00413, SRS\_BSW\_00414, SRS\_BSW\_00415,  
SRS\_BSW\_00417, SRS\_BSW\_00423, SRS\_BSW\_00424, SRS\_BSW\_00425,  
SRS\_BSW\_00426, SRS\_BSW\_00427, SRS\_BSW\_00428, SRS\_BSW\_00429,  
SRS\_BSW\_00432, SRS\_BSW\_00433, SRS\_BSW\_00005, SRS\_BSW\_00006,  
SRS\_BSW\_00009, SRS\_BSW\_00010, SRS\_BSW\_00159, SRS\_BSW\_00160,  
SRS\_BSW\_00161, SRS\_BSW\_00162, SRS\_BSW\_00164, SRS\_BSW\_00167,  
SRS\_BSW\_00168, SRS\_BSW\_00172)