

Document Title	Explanation of Application Interface of AD/ADAS vehicle motion control
Document Owner	AUTOSAR
Document Responsibility	AUTOSAR
Document Identification No	988

Document Status	published
Part of AUTOSAR Standard	Classic Platform
Part of Standard Release	R22-11

Document Change History			
Date	Release	Changed by	Description
2022-11-24	R22-11	AUTOSAR Release Management	<ul style="list-style-type: none"> • Add definition of PLN2 and VMC1 • Revision of Functional description of ADAS Application • Revision of ADAS Manager functions and function description • Add Appendix A and revision of Appendix B
2021-11-25	R21-11	AUTOSAR Release Management	<ul style="list-style-type: none"> • Add Curvature request interface • Add interface list as appendix • Expand ADAS function scope: ACC to include standstill, LKA to remove speed limit
2020-11-30	R20-11	AUTOSAR Release Management	Initial release

Disclaimer

This work (specification and/or software implementation) and the material contained in it, as released by AUTOSAR, is for the purpose of information only. AUTOSAR and the companies that have contributed to it shall not be liable for any use of the work.

The material contained in this work is protected by copyright and other types of intellectual property rights. The commercial exploitation of the material contained in this work requires a license to such intellectual property rights.

This work may be utilized or reproduced without any modification, in any form or by any means, for informational purposes only. For any other purpose, no part of the work may be utilized or reproduced, in any form or by any means, without permission in writing from the publisher.

The work has been developed for automotive applications only. It has neither been developed, nor tested for non-automotive applications.

The word AUTOSAR and the AUTOSAR logo are registered trademarks.

Contents

1	Introduction	5
2	Description of Terms and Concepts	6
2.1	Axis System	6
2.2	Definitions	7
2.2.1	Centre of gravity of passenger car	7
2.2.2	Polar coordinate system	8
2.2.3	Vehicle acceleration/propulsive force direction	8
2.2.4	Cant direction	9
2.2.5	Steering wheel angle	9
2.2.6	Road Variables	10
2.2.7	Curvature request	11
2.2.8	Definition of the car surroundings	12
2.3	Acronyms and Abbreviations	14
2.4	General remarks	15
2.4.1	Limitations	15
2.4.2	Sensor signals	15
2.4.3	Functional Safety	15
2.4.4	Assumption for ADAS Application	15
3	Related Documentation	16
4	Architecture Overview	17
4.1	Functional Structure	17
4.1.1	ADAS Application	19
4.1.2	ADAS-MGR	20
4.1.3	Vehicle-MGR	21
4.1.4	Actuator	22
4.2	Interface	23
4.3	Scalability	24
4.3.1	ACC	24
4.3.2	AEB	25
4.3.3	LKA	26
5	Description of the Chassis Domain Software Compositions and Components for VMC Architecture implementation	27
5.1	VMC Architecture as new SW-Components	27
6	Appendix	30
6.1	Appendix A: Outage of ADAS Application	30
6.1.1	Premise	30
6.1.2	Classification of information regarding ADAS Application outages	30
6.1.3	Interface signal listed in Interface list	31

- 6.1.4 Interface signals not covered by the description 31
- 6.2 Appendix B: Interface list 32

1 Introduction

This document explains the pattern for architecture of the Vehicle Motion Control Interface and its software components, as well as the design decisions that leads to an update of the Application Interface within Chassis Domain, as depicted in Figure 1.1.

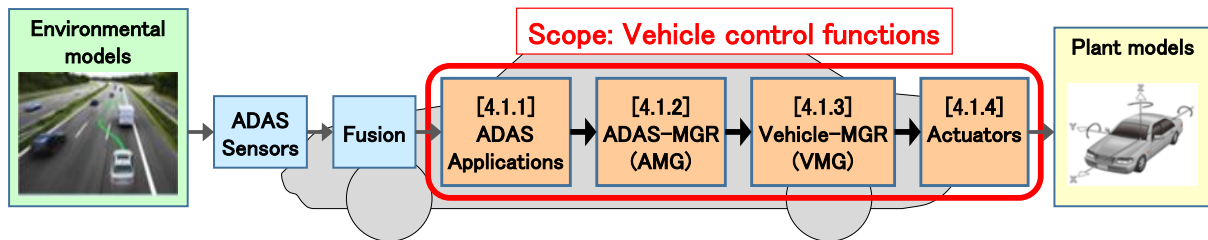

Figure 1.1: Scope of this document

The scope of the vehicle control functions in this document is "Implementation of ADAS requirements" only. The document will focus on a recommended signal cascading architecture for ADAS function (particularly for ACC, AEB and LKA functions), for which new SW-Components will be created. For other chassis components, including vehicle stabilization controls (ABS/TCS, etc.), refer to [1, AUTOSAR_EXP_AIChassis].

The purpose of defining the architecture (functional structure, I/F) in this document is to improve customer convenience in function development and development efficiency in non-competitive areas by achieving the ease of function update/change, the ease of design and verification and the ease of mutual understanding.

2 Description of Terms and Concepts

This document refers to the formulation of unified Application Interfaces of the Domain Chassis in the frame of a specific pattern implementation of Advanced Driver Assistance Systems (ADAS) with a specific Vehicle Motion Control interface. The results of the Domain Chassis shall be aligned with the other domains, e.g. Body, Powertrain, Occupant and Pedestrian Safety. The Application Interface Table represents a good basis for this alignment and detection of conflicts.

2.1 Axis System

The standard coordinate system used by the Chassis Domain refers to the International Standard [2, ISO 8855]. Whether a fixed geometry point (e.g. near to the average Centre of Gravity (CoG) of all variants of a vehicle type) is used as a reference point for basic Centre of Gravity has to be decided on project level.

2.2 Definitions

2.2.1 Centre of gravity of passenger car

The car's chassis-fixed coordinate system's origin lies in the middle of the Front Axle (FA) see Figure 2.1. The car's centre of gravity is defined as the origin of a chassis-free coordinate system that is positioned relative to the FA coordinate system. The orientations of both these coordinate systems' axes are defined as follows:

With the car moving forward:

- x is positive to the front of the car
- y is positive to the left of the car
- z is positive to the top of the car
- Roll is positive in a left-hand bend, when the car body tips to the right-hand side
- Pitch is positive when a car is braking and the car body tips forward
- Yaw is positive in a left-hand bend

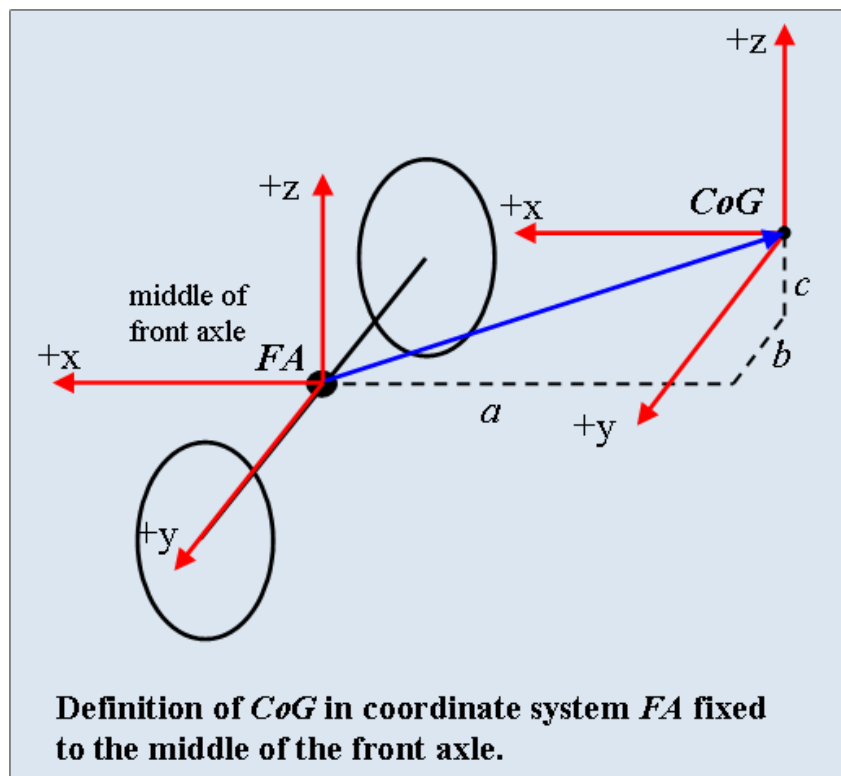

Figure 2.1: Definition of a car's Centre of Gravity (CoG)

2.2.2 Polar coordinate system

The polar coordinate system is defined as follows:

- With the vehicle moving forward, ϕ is positive in the counter clockwise direction

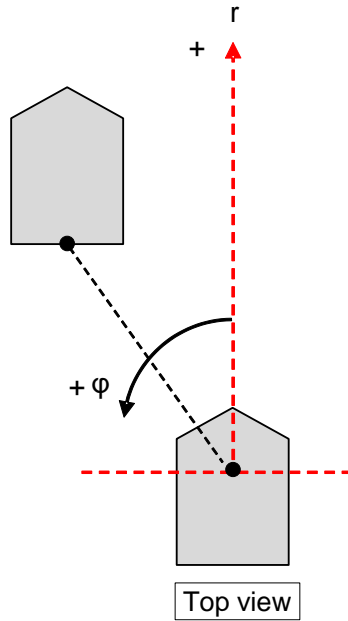

Figure 2.2: Polar coordinates system

2.2.3 Vehicle acceleration/propulsive force direction

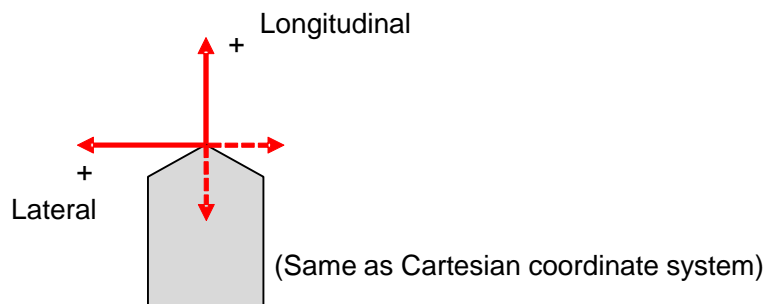

Figure 2.3: Plus, or minus sign of vehicle acceleration/propulsive force

Deceleration is expressed as negative value.

2.2.4 Cant direction



Figure 2.4: Plus, or minus sign of cant

2.2.5 Steering wheel angle

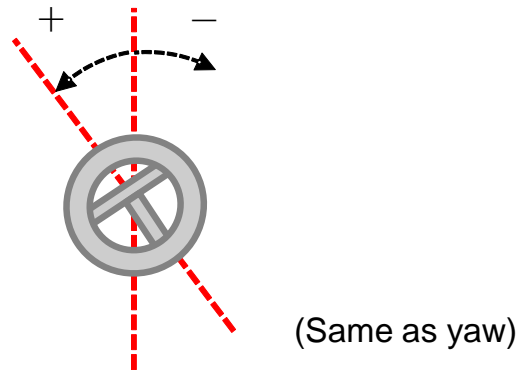

Figure 2.5: Plus, or minus sign of steering wheel angle

2.2.6 Road Variables

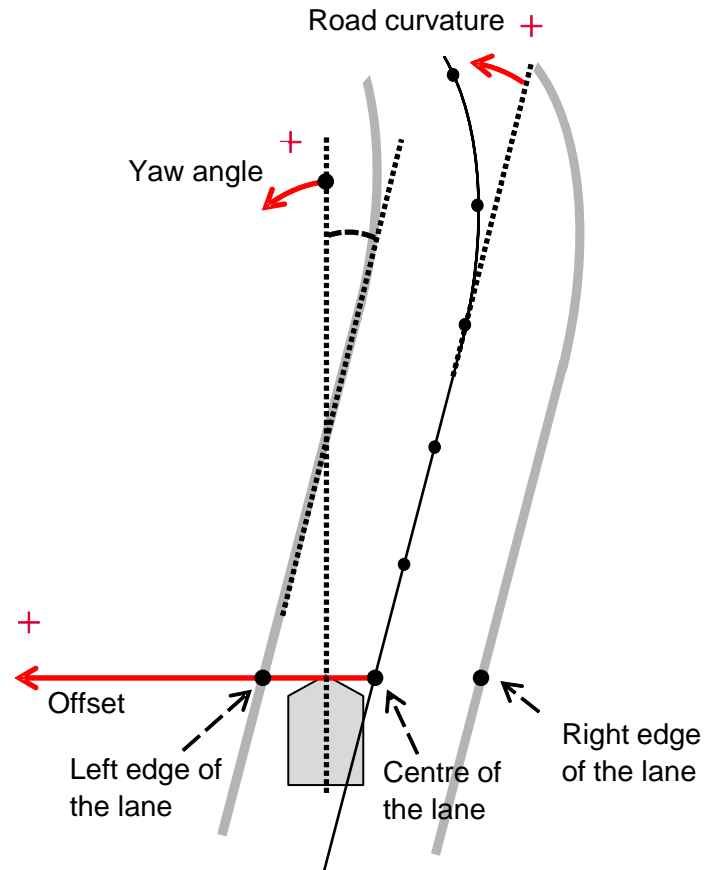

Figure 2.6: Variables of road

2.2.7 Curvature request

Based on the desired trajectory from vehicle position, calculate corresponding curvature request.

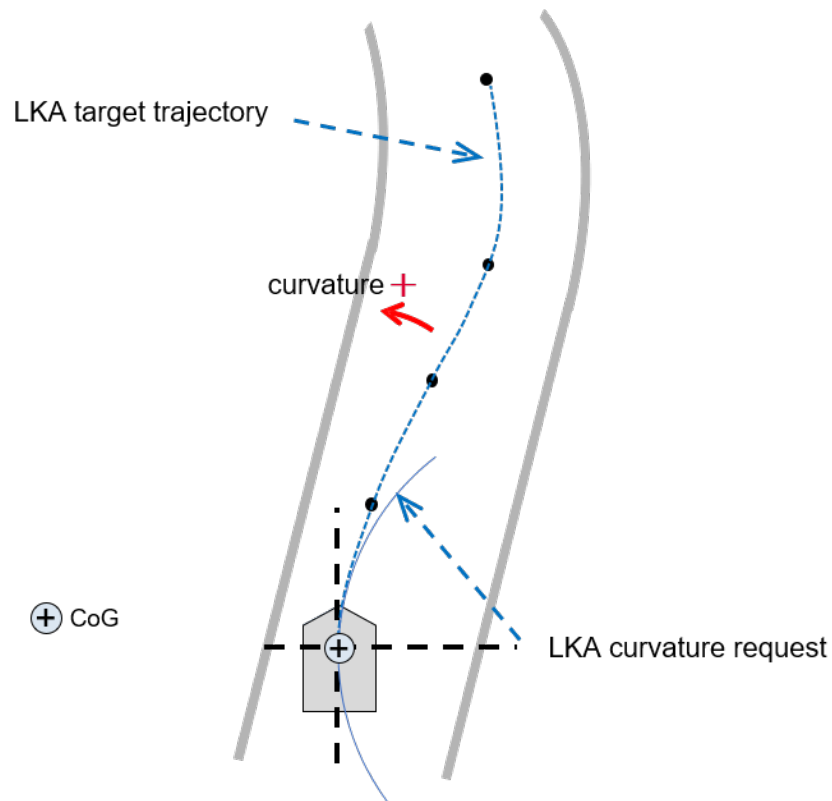

Figure 2.7: Curvature request

Path curvature request is defined relative to the trajectory on a fixed point, which unless otherwise stated, is the CoG.

2.2.8 Definition of the car surroundings

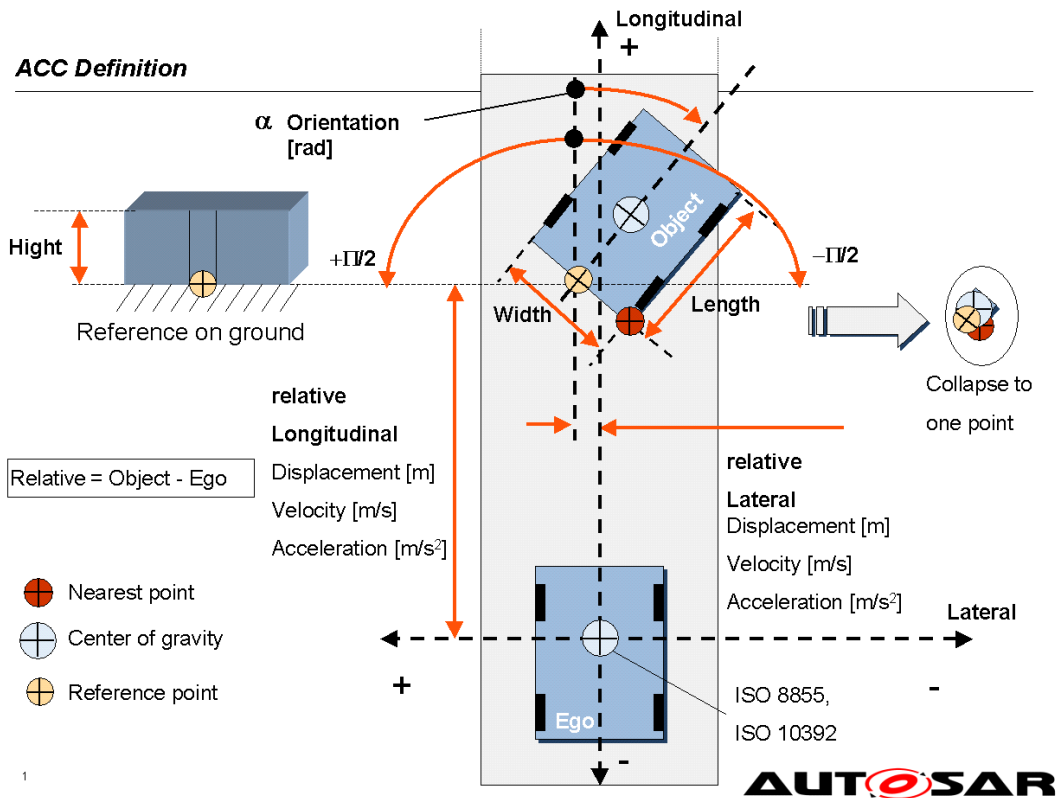

Figure 2.8: Definition of car surrounding for ACC

Predicted Course

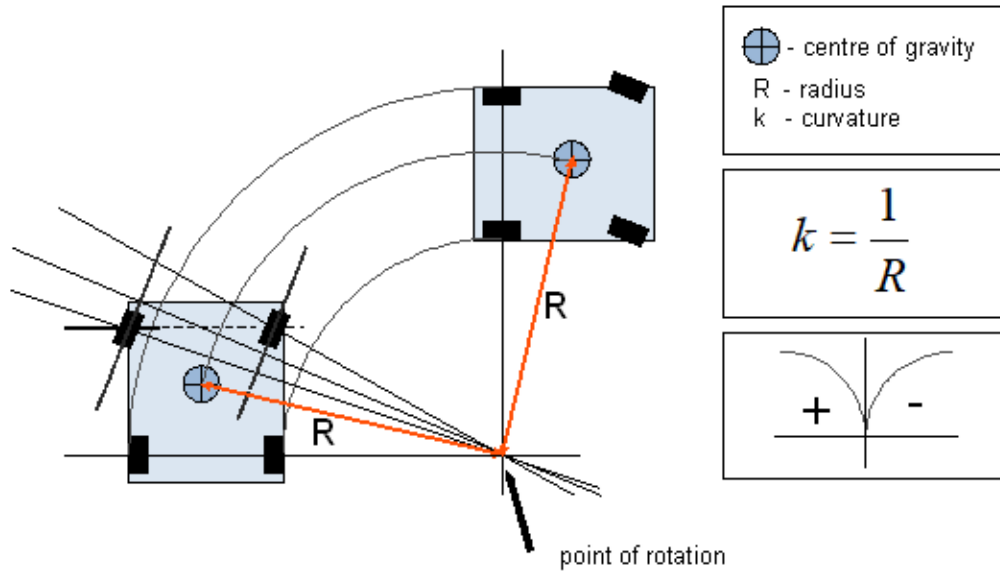

Figure 2.9: Definition of predicted course

2.3 Acronyms and Abbreviations

Please also refer to [3, AUTOSAR_TR_Glossary] for explanation of commonly used terms and abbreviations within AUTOSAR.

Abbreviation / Acronym:	Description:
ABS	Antilock Braking System
ACC	Adaptive Cruise Control
ACL	Acceleration
ACT	Actuator
ADAS	Advance Driver Assistance System
AEB	Autonomous Emergency Braking
BAS	Brake Assist
BRK	Brake
BRWS	Basic Rear Wheel Steering
BSTS	Basic Steering Torque Superposition
BSAS	Basic Steering Angle Superposition
CBC	Cornering Brake Control
CoG	Centre of Gravity
DAS	Driver Assistance System
DTC	Regulation of the Drag Torque
EBD	Electronic Brake Force Distribution
ECU	Electronic Control Unit
EPB	Electronic Parking Brake
ESC	Electronic Stability Control
FA	Front Axle
HDC	Hill Decent Control
HHC	Hill Hold Control
HMI	Human Machine Interface
HW	Hardware
I/F	Interface
LKA	Lane Keep Assist
MGR	Manager
NVH	Noise, Vibration, Harshness
OEM	Original Equipment Manufacturer
PT	Powertrain
RA	Rear Axle
RSC	Roll Stability Control
SR	Situation Recognition
SSM	Stand Still Manager/Management
STR	Steering
SW	Software
SW-C	Software Component
TCS	Traction Control System
VFB	Virtual Function Bus
VGR	Variable Gear Ratio
VLC	Vehicle Longitudinal Control
VM	Vehicle Model
VMC	Vehicle Motion Control
VSS	Vehicle State Sensors
YRC	Yaw Rate Control

2.4 General remarks

2.4.1 Limitations

The logical architectures proposed do not restrict the development or products of companies or organizations participating in AUTOSAR.

2.4.2 Sensor signals

In ADAS, signals of different processing levels are handled for I/F definition.

- Raw signal: Raw sensor data without pre-processing
- Pre-processed signal: Pre-processed sensor data. Abstraction of sensor hardware
- Fused signal: Several sensor signals are processed to generate a fused signal

Raw signals (raw data) should not be used as standard I/F because they are hardware dependent.

2.4.3 Functional Safety

Most ADAS domain signals are considered as relevant to safety. It is assumed that in this document, reliable methods of communication are available. No specification of communication methods is provided in this document.

Dynamic design and safety concepts are not considered in this document. In order to prove that the discussed use cases are safety compliant (in accordance with the definition of [4, ISO 26262], [5, ISO 21448], etc.), studies across all applicable domains will be necessary, and these must be performed at the project level.

2.4.4 Assumption for ADAS Application

This document applies the architecture to three ADAS Applications (ACC, AEB, and LKA).

Assumptions for these three applications are shown below:

- ACC: Applies to all vehicle speed ranges including standstill condition.
- AEB: Does not include restarting after stopping.
- LKA: Applies to lane keeping assist functions on highways or motorways in ideal grip condition (e.g., low wheel slips, low accelerations, exact condition that qualify as "ideal grip" can be project specific if necessary).

3 Related Documentation

[6, "JASPAR Standards Document: ST-AVI-1"] is also used as a reference for this document.

- [1] Explanation of Application Interfaces of the Chassis Domain
AUTOSAR_EXP_AIChassis
- [2] ISO 8855:2011, Road vehicles – Vehicle dynamics and road-holding ability – Vocabulary
<http://www.iso.org>
- [3] Glossary
AUTOSAR_TR_Glossary
- [4] ISO 26262:2018 (all parts) – Road vehicles – Functional Safety
<http://www.iso.org>
- [5] ISO/PAS 21448:2019 – Road vehicles – Safety of the intended functionality
<http://www.iso.org>
- [6] JASPAR Standards Document: ST-AVI-1 – AD/ADAS Vehicle Motion Control Interface Specification Ver. 3.01
<https://www.jaspar.jp/en>

4 Architecture Overview

4.1 Functional Structure

This document defines the vehicle control functions for ADAS in four layers. (Thick bordered frame in Figure 4.1).

1. ADAS Application
2. ADAS-MGR
3. Vehicle-MGR
4. Domain Actuators (+ related Domain Sensors)

A MGR layer is set for each ADAS and actuator system and the I/F between each layer is standardized in order to loosen the relationship between the ADAS Applications and Actuators, and reduce the effect that adding or changing functions for one element has on another. For example, the effect of adding or changing a function for the ADAS system can be absorbed in the ADAS-MGR layer. ADAS-MGR can communicate with Vehicle-MGR via the standardized I/F, which reduces the effects on subsequent functions. Also, it can make it easier to add and/or change actuators without drastically affecting the Vehicle-MGR; the reduction in interdependency can also simplify functional safety analysis of the system.

The whole ADAS architecture consists of the four layers above, ADAS Sensor layer and Fusion layer. Examples of ADAS Sensors include vision sensors (e.g., camera), radar, and LiDAR. ADAS Sensors monitor the vehicle surroundings and send raw signals (raw data) or pre-processed signals to the Fusion layer. The Fusion layer fuses signals from each sensor to recognize surrounding conditions. The recognition results are sent to the ADAS Application layer.

This document does not cover ADAS Sensors and Fusion layers that do not have a direct I/F with vehicle control, as described in Figure 1.1. As a general rule, where possible, interaction between the actuators is avoided in the VMC architecture.

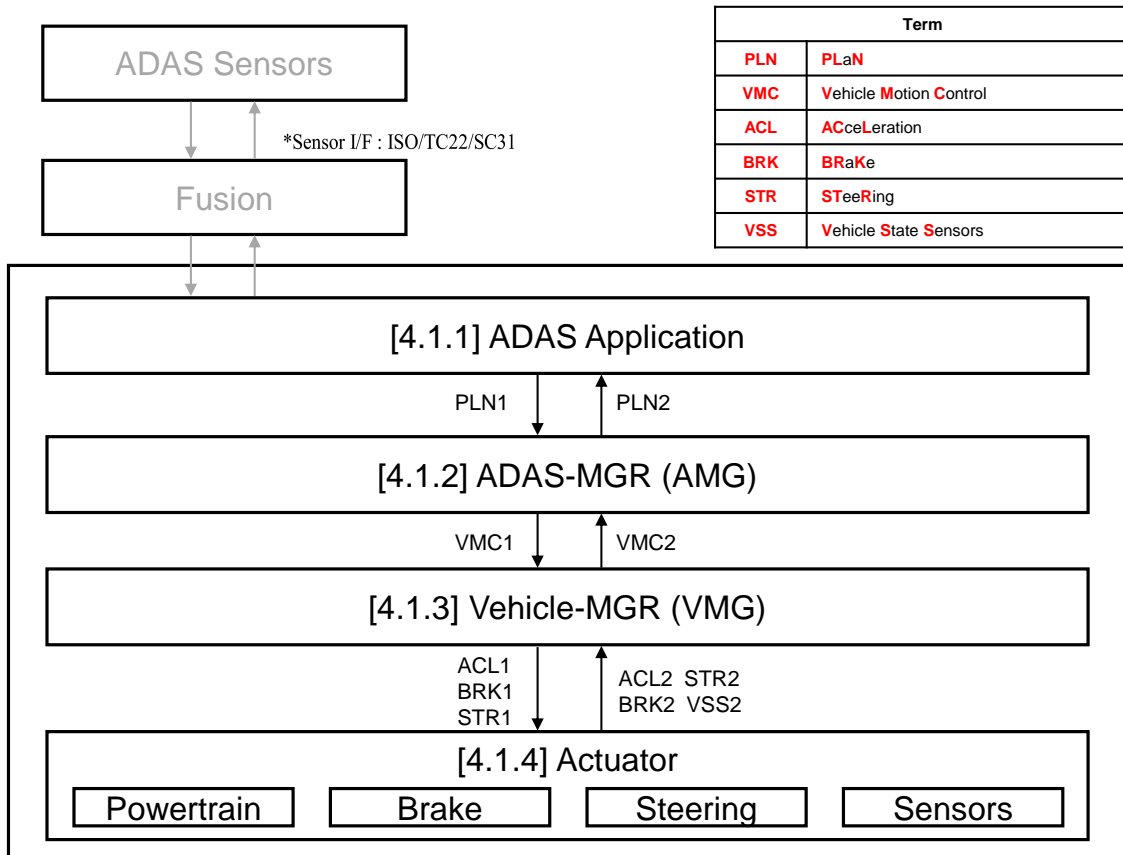

Figure 4.1: Functional architecture of vehicle control

Table 4.1 shows the main I/Fs between layers.

I/F	Explanation
PLN1	I/F from ADAS Application layer to ADAS-MGR layer
PLN2	I/F from ADAS-MGR layer to ADAS Application layer
VMC1	I/F from ADAS-MGR layer to Vehicle-MGR layer
VMC2	I/F from Vehicle-MGR layer to ADAS-MGR layer
ACL1	I/F from Vehicle-MGR layer to Actuator layer (Powertrain)
ACL2	I/F from Actuator layer (Powertrain) to Vehicle-MGR layer
BRK1	I/F from Vehicle-MGR layer to Actuator layer (Brake)
BRK2	I/F from Actuator layer (Brake) to Vehicle-MGR layer
STR1	I/F from Vehicle-MGR layer to Actuator layer (Steering)
STR2	I/F from Actuator layer (Steering) to Vehicle-MGR layer
VSS2	I/F from Actuator layer (Sensor) to Vehicle-MGR layer

Table 4.1: Main I/Fs between layers

4.1.1 ADAS Application

The functions of the ADAS Application are shown in Figure 4.2 and Table 4.2.

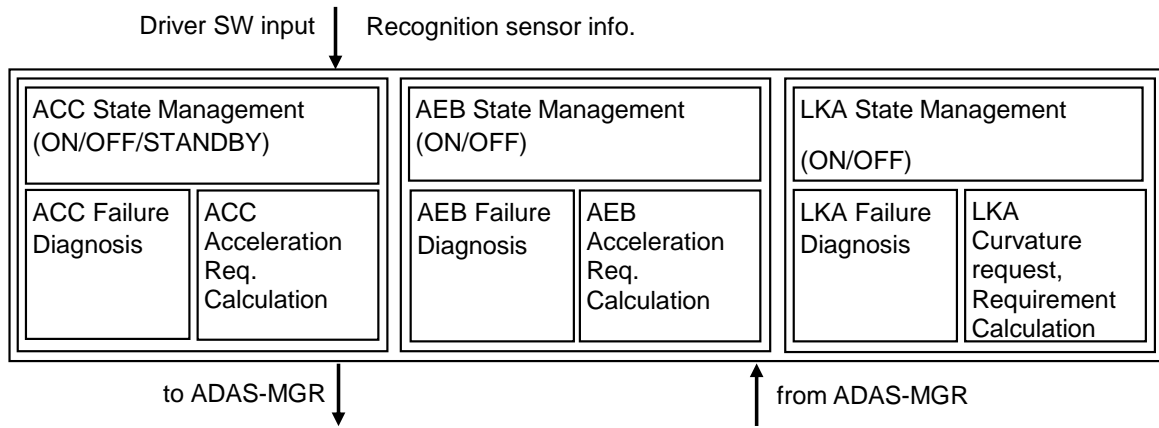

Figure 4.2: ADAS Application functions

Function
Based on a driver assist request via a user interface, such as a switch and/or recognition sensor information, each ADAS Application requests as individual kinematic plan (longitudinal acceleration/deceleration, Curvature request, etc.) for complying with regulation as well as securing safety and/or comfort.
Each ADAS Application performs failure detection and function stop judgement, manages the internal state, and takes actions according to the internal state.
Each ADAS Application acts based on status of the ADAS Application selected by ADAS-MGR.

Table 4.2: Functional description of ADAS Application

4.1.2 ADAS-MGR

The functions of the ADAS-MGR are shown in Figure 4.3 and Table 4.3.

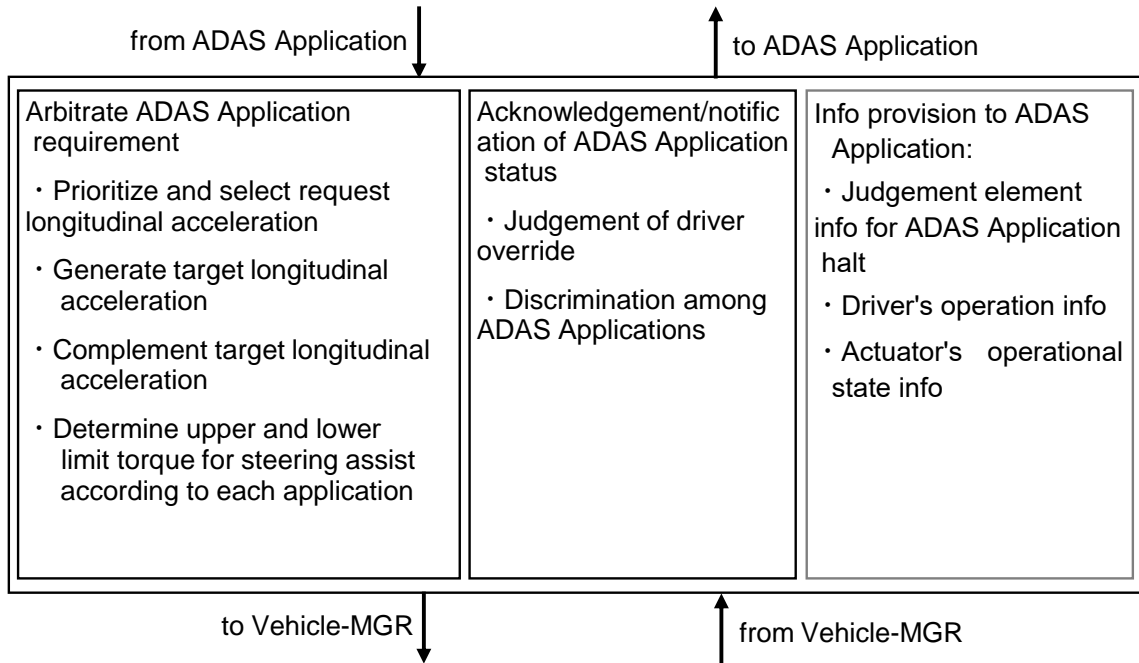

Figure 4.3: ADAS-MGR functions

Function
ADAS-MGR arbitrates individual requested kinematic plans from each ADAS Application and integrates ADAS kinematic plan for securing safety and/or comfort.
ADAS-MGR requests Vehicle-MGR for arbitration mode of the requested kinematic plan (including preparations for the kinematic plan) and driver operations.
ADAS-MGR judges the override by the drivers acceleration/braking/steering maneuver based on the vehicle state, and informs each ADAS Application of the results of arbitration of the kinematic plan request and the selected ADAS Application.
ADAS-MGR provides ADAS Application with judgement element info for its halt. At this time, information from various Sensors and Actuators that cause halt (e.g. seating sensor information, engine reliability information, etc.) is abstracted into information that does not depend on a specific system configuration (e.g. occupant state, drive system state, etc.), and is communicated to ADAS Applications. (* Supplementary explanation of this function is described in Chapter 6.1 Appendix A: Outage of ADAS Application)

Table 4.3: Functional description of ADAS-MGR

4.1.3 Vehicle-MGR

The functions of the Vehicle-MGR are shown in Figure 4.4 and Table 4.4.

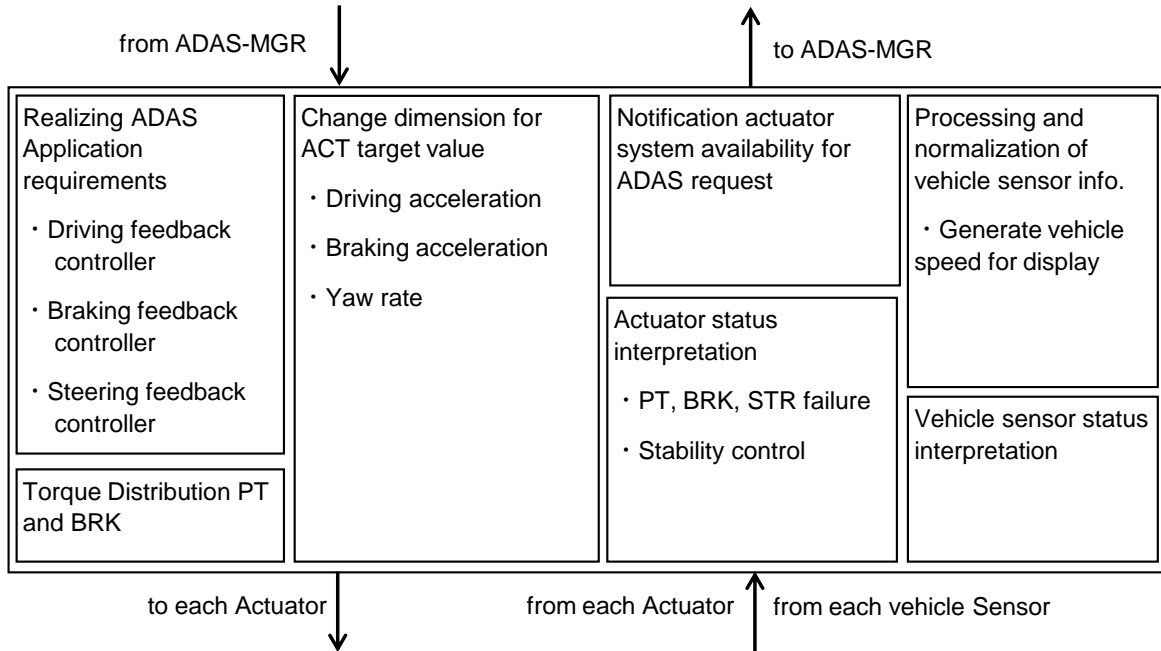

Figure 4.4: Vehicle-MGR functions

Function
Vehicle-MGR calculates/distributes the motion request (driving, braking, steering) for the Actuator system in order to realize the kinematic plan requested by ADAS-MGR.
Vehicle-MGR requests each Actuator for the arbitration mode between the motion request and driver operation request.
Vehicle-MGR informs ADAS-MGR of the vehicle status based on each Actuator system status and momentum sensing information that have been processed if needed.

Table 4.4: Functional description of Vehicle-MGR

4.1.4 Actuator

Table 4.5 shows a functional description of an Actuator system.

Function
Actuator system realizes vehicle motion request (driving, braking, steering) based on driver operation.
Actuator system realizes vehicle motion request (driving, braking, steering) from Vehicle-MGR.
Each Actuator system realizes vehicle motion request based on arbitration request from Vehicle-MGR.
Actuator system notifies Vehicle-MGR of ON/OFF information about driver operation (accelerator pedal, brake pedal, holding steering wheel).
Actuator system notifies Vehicle-MGR of status of Actuator system (driving, braking, steering).
Actuator system notifies Vehicle-MGR of information about vehicle momentum.

Table 4.5: Functional description of Actuator system

The Actuator system consists of following sub-systems.

a) Powertrain

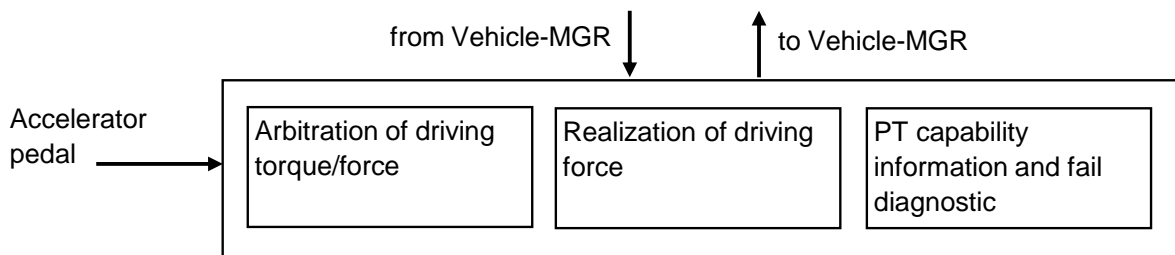

Figure 4.5: Powertrain system functions

b) Brake

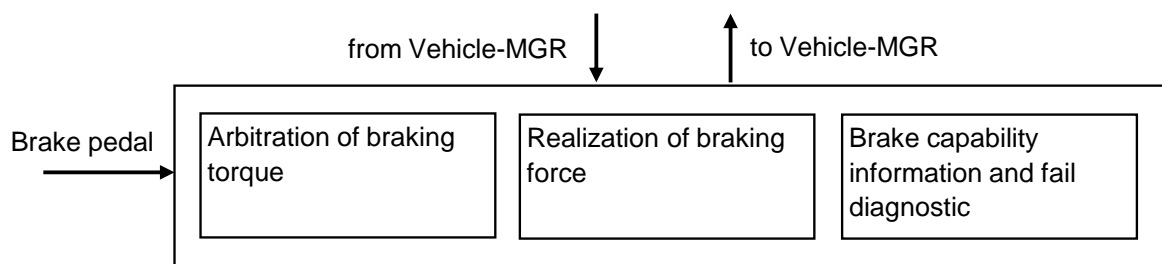

Figure 4.6: Brake system functions

c) Steering

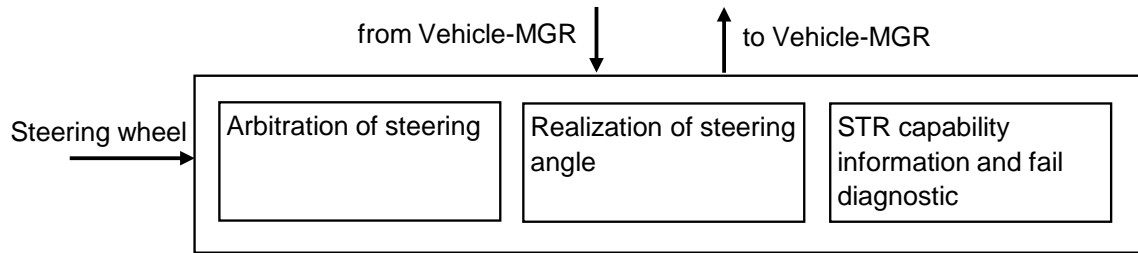

Figure 4.7: Steering system functions

4.2 Interface

For details, please refer to Chapter 6.2 Appendix B: Interface list.

4.3 Scalability

Use cases of applying this architecture to ACC, AEB, and LKA are shown below. The I/F or functions to be used can be selected to enable the scalability of this architecture even when combining multiple ADAS Applications or adding Applications in the future.

4.3.1 ACC

Figure 4.8 shows a use case that uses ACC only.

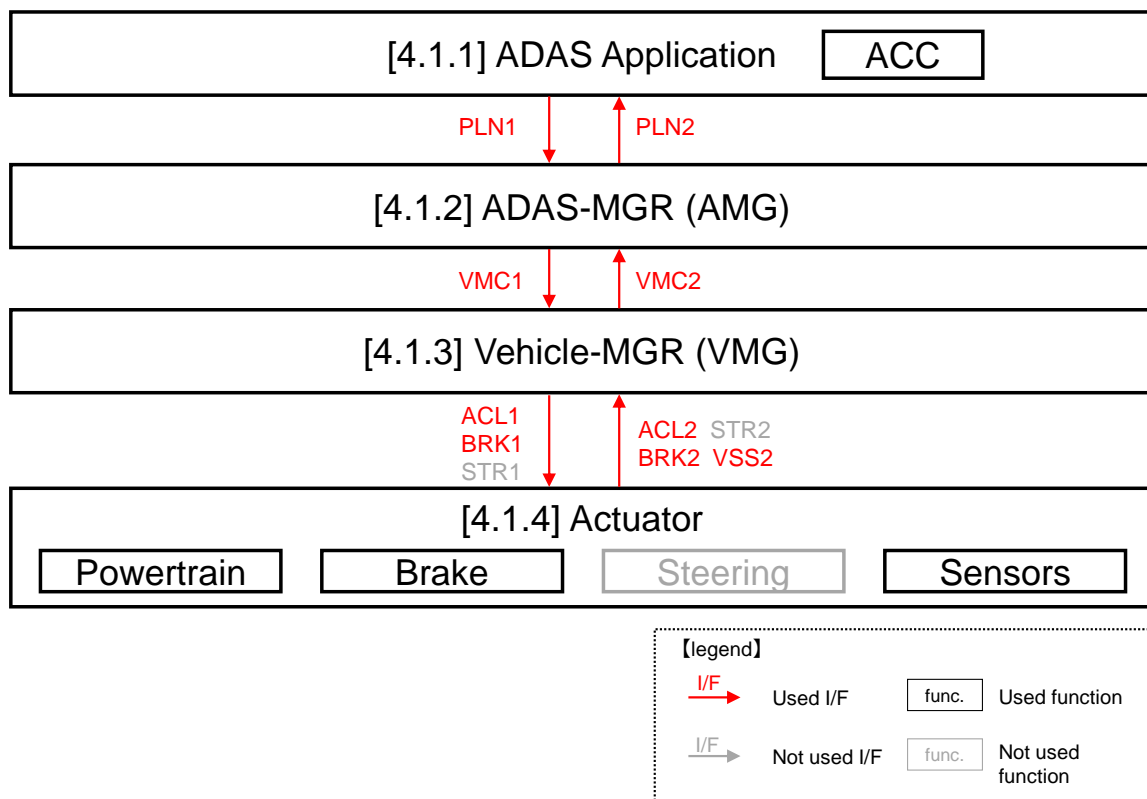

Figure 4.8: Use case: ACC

4.3.2 AEB

Figure 4.9 shows a use case that uses AEB only.

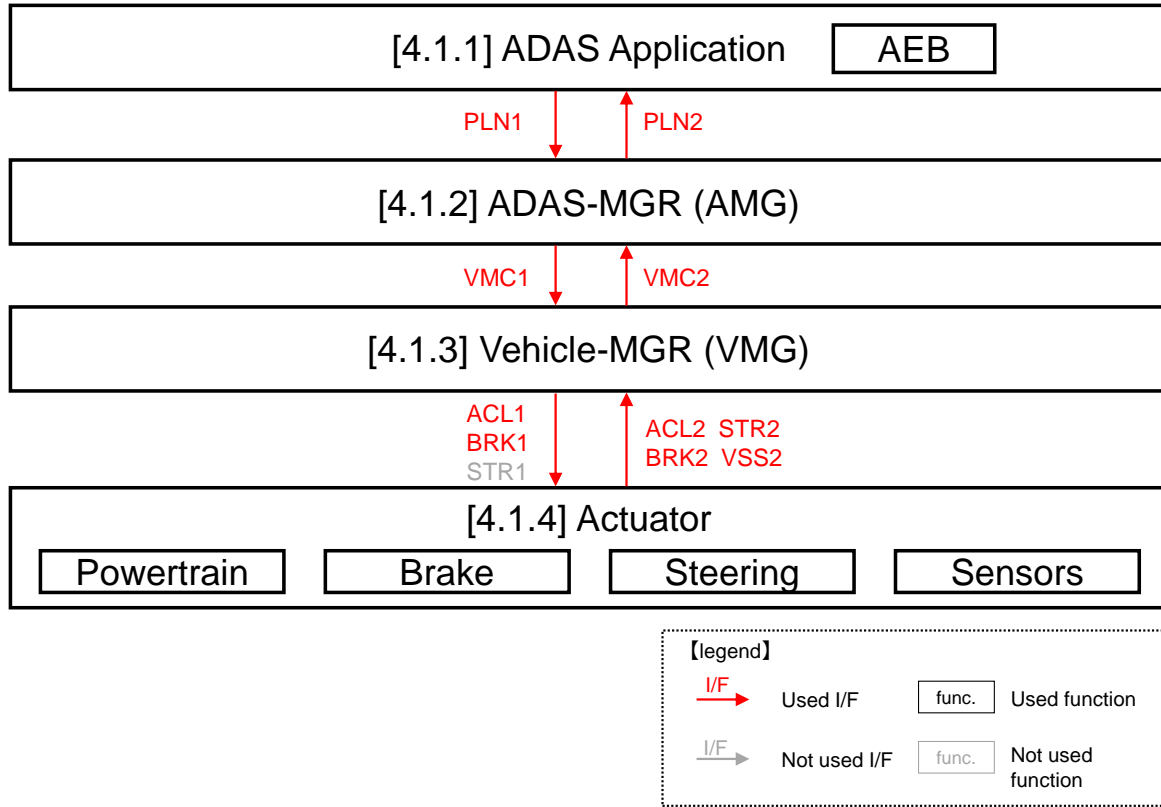

Figure 4.9: Use case: AEB

4.3.3 LKA

Figure 4.10 shows a use case that uses LKA only.

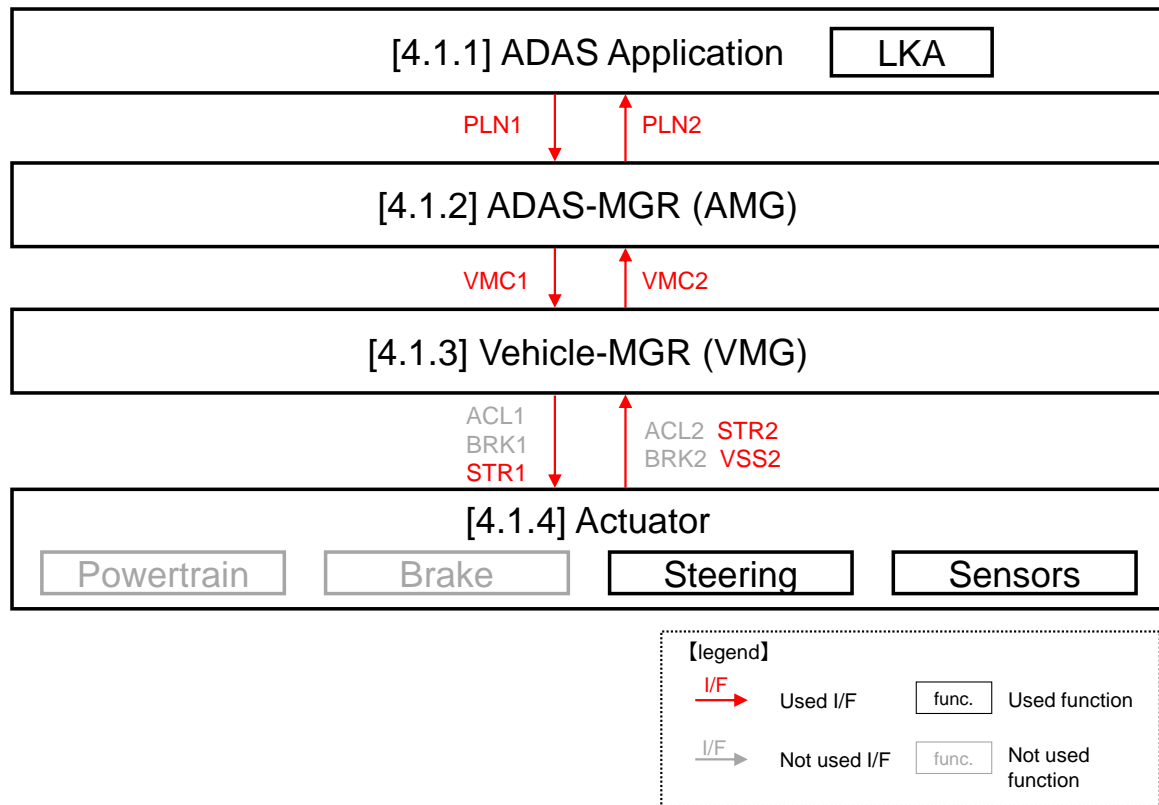

Figure 4.10: Use case: LKA

5 Description of the Chassis Domain Software Compositions and Components for VMC Architecture implementation

5.1 VMC Architecture as new SW-Components

The implementation of ADAS functionalities within the Chassis Domain was already introduced through the Application Interfaces (Figure 5.1 and Figure 5.2).

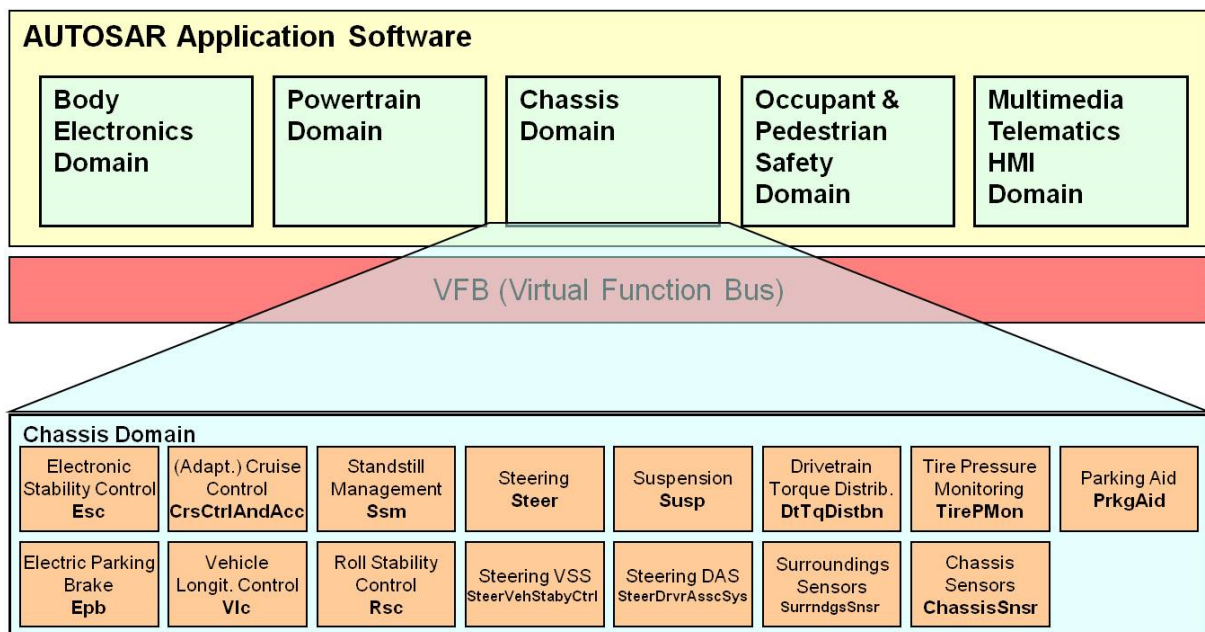

Figure 5.1: Chassis Domain Overview

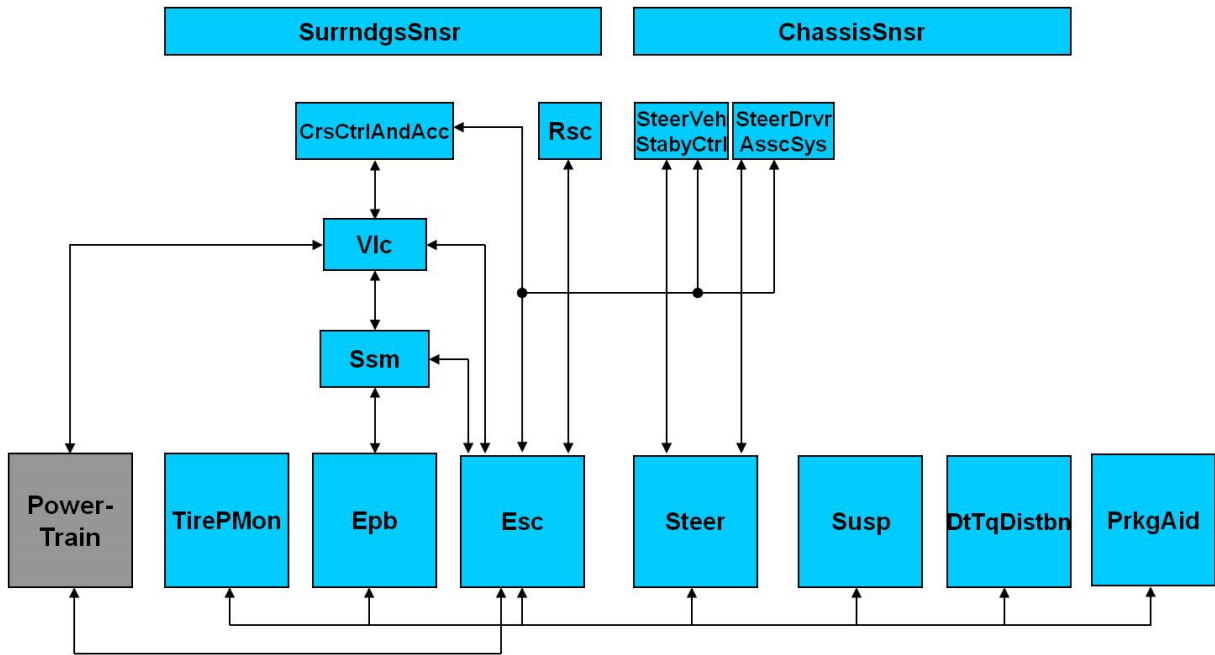

Figure 5.2: Example of a Chassis Domain Structure

In addition, as mentioned in the example of Chapter 5.1 of [1, AUTOSAR_EXP_AIChassis], several structures can be discussed to arrange the global architecture of the functional components, as in following example (Figure 5.3):

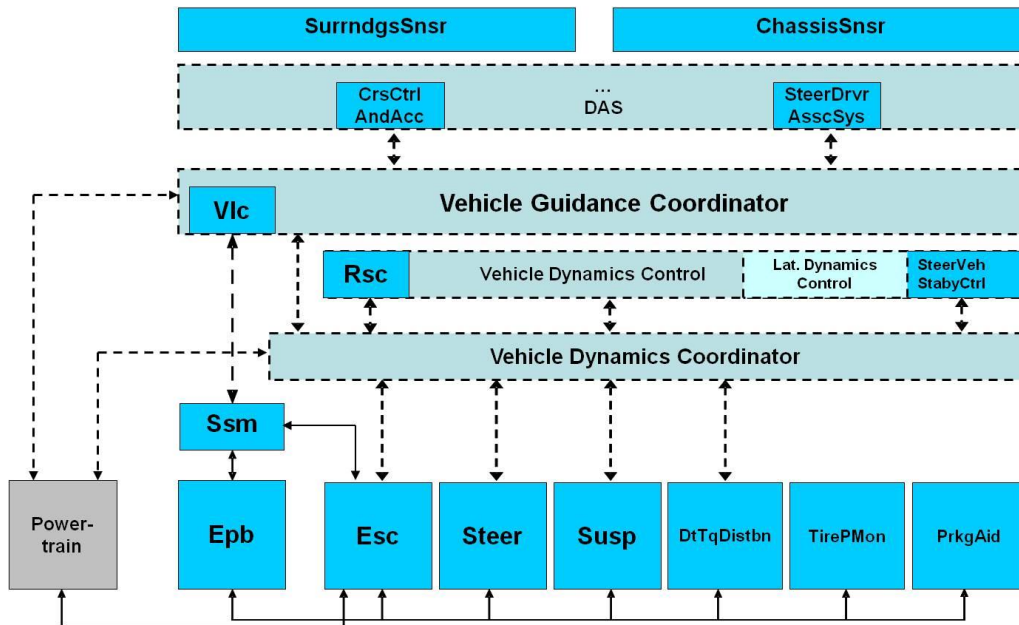

Figure 5.3: Example of a dedicated structure of existing AI Chassis domain components for ADAS purpose

The understanding of the VMC architecture should also be interpreted as another Chassis Domain structure, for which each layer of the VMC architecture can or cannot be composed of other existing Chassis Domain SW-Components.

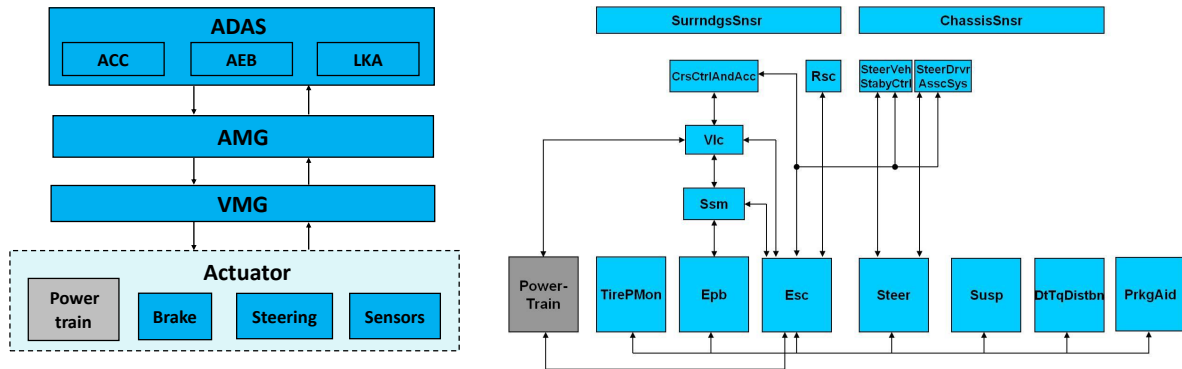

Figure 5.4: New Example of VMC Structure (left) compared to Example of Chassis Domain Structure (right)

The scope of this document is limited only to the definition of the interfaces between the SW-Components that comprise the VMC architecture: ADAS, AMG, VMG and (existing) Actuators/Sensors. Therefore, the content of each components is left up to project convenience and the way the existing SW-Components is integrated in VMC architecture is not defined in this document. However, in case the VMC architecture is implemented along the existing SW-Components in AI Chassis domain, it will be needed to:

- limit the information flow from currently existing Chassis Domain SW-C ports
- consider arbitration gates that will be defined through new SW-Components.

6 Appendix

6.1 Appendix A: Outage of ADAS Application

6.1.1 Premise

Various ADAS Applications are required to stop (or degenerate) its functionality in the event of an abnormality in the ADAS system or under situation that occupants cannot safely use the ADAS function, and so on. Since the stop judgment conditions and stop timing of ADAS Applications differ depending on each application, it is necessary to secure flexibility in application design. From this point of view, this document assumes that the stop judgment function of the ADAS Application is placed in each ADAS Application, and the information providing function that is the judgment material for the stop judgment is placed in the ADAS-MGR layer.

6.1.2 Classification of information regarding ADAS Application outages

Figure 6.1 shows an example of classification of information related to ADAS Application halt.

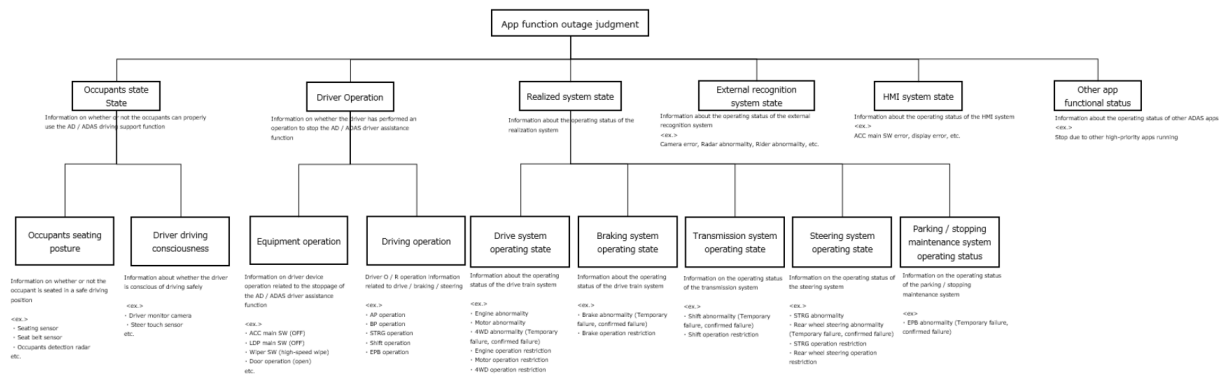

Figure 6.1: Classification example of information on ADAS Application halt

6.1.3 Interface signal listed in Interface list

The interface signals based on the classification examples in Figure 6.1 are shown in Interface list for those shown in Figure 6.2.

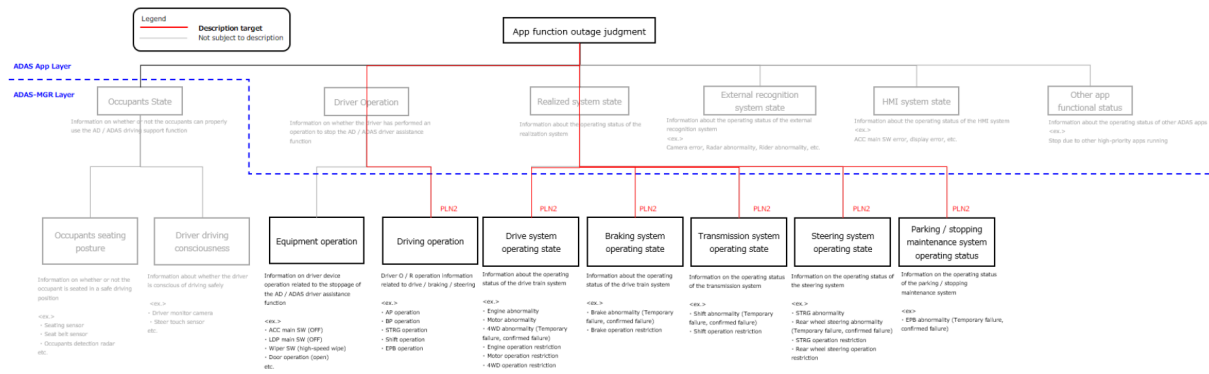

Figure 6.2: Target Interface signal listed in Interface list

6.1.4 Interface signals not covered by the description

The Interface signals associated with the information classifications excluded from the Interface table in Figure 6.2 were judged that it was not appropriate to define the standard Interface signal in this Working Group. This is because they are out of scope of this document (see Chapter 1) and ADAS Application’s detail behavior differs depending on each OEM company in spite of the same ADAS Application (e.g., ACC, AEB, LKA). However, from the viewpoint of facilitating the addition and modification of functions, which is the aim of this document, it is recommended for OEM companies to define Interface signals based on the same viewpoint within OEM even for excluded information classifications. Below is an example of the definition of Interface signals based on the information classification of "Occupants state".

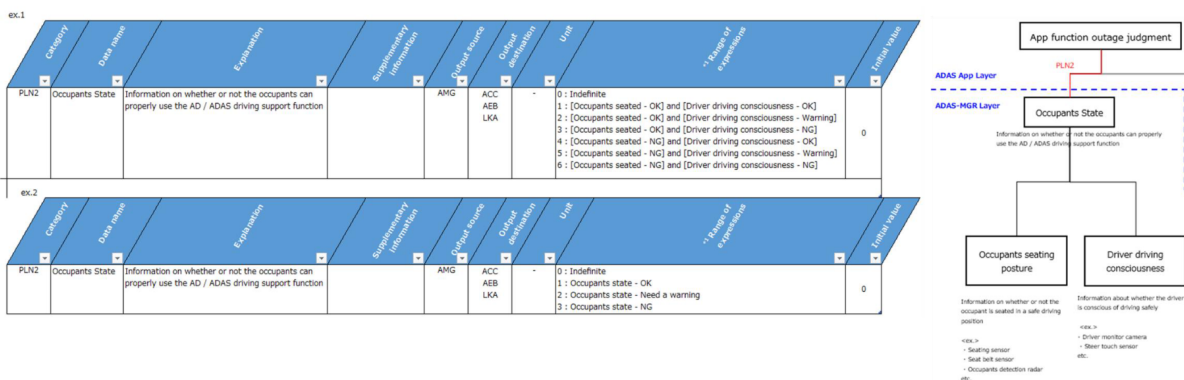

Figure 6.3: Occupants state

6.2 Appendix B: Interface list

No	Set	ACC	AEB	LKA	Type	Data name	Explanation	Supplementary information	Output source	Output dest.	Unit	Range of expressions
PLN1												
1	PLN1-2	○			ACC request	ACC target acceleration	Indicates the target acceleration that guarantees ACC performance		ACC	AMG	m/s ²	init value:0
2		○			ACC status	ACC target acceleration validity information	Indicates whether the ACC target acceleration is valid or invalid		ACC	AMG	-	0: Invalid 1: Valid init value:0
3		○			ACC status	ACC status	Indicates the ACC control status		ACC	AMG	-	0: OFF 1: STANDBY 2: ON init value:0
4		○			ACC request	ACC standstill control request	Indicates whether the ACC standstill control is requested or not		ACC	AMG	-	0: Not requested 1: Requested init value:0
5	PLN1-6		○		AEB request	AEB target acceleration	Indicates the target acceleration that guarantees AEB performance		AEB	AMG	m/s ²	init value:0
6			○		AEB status	AEB target acceleration validity information	Indicates whether the AEB target acceleration is valid or invalid		AEB	AMG	-	0: Invalid 1: Valid init value:0
7			○		AEB status	AEB status	Indicates the AEB control status		AEB	AMG	-	0: OFF 1: 2: ON (Standby) 3:Warning 4:Deceleration preparation (+ Warning) 5:Soft deceleration (+ Warning) 6:Strong deceleration (+ Warning) 7:Vehicle stop hold init value:0
8			○		AEB request	AEB standstill control request	Indicates whether the AEB standstill control is requested or not		AEB	AMG	-	0: Not requested 1: Requested init value:0
9	PLN1-10			○	LKA request	LKA target curvature	Indicates the LKA target curvature		LKA	AMG	1/m	init value:0
10				○	LKA request	LKA target curvature validity information	Indicates whether the LKA target curvature is valid or invalid		LKA	AMG	-	0:Invalid 1:Valid init value:0
11				○	LKA status	LKA status	Indicates the LKA control status		LKA	AMG	-	0 : OFF 1 : STANDBY 2 : ON init value:0
PLN2 (1)												
1		○	○	○		Driver operation (Drive)	Indicates the presence or absence of override operation (drive) to stop the AD / ADAS driving support function		AMG	ACC AEB LKA	-	0 : Indefinite 1 : Not operate 2 : Operate init value:0
2		○	○	○		Driver operation (Braking)	Indicates the presence or absence of override operation (braking) to stop the AD / ADAS driving support function		AMG	ACC AEB LKA	-	0 : Indefinite 1 : Not operate 2 : Operate init value:0
3		○	○	○		Driver operation (Steering)	Indicates the presence or absence of override operation (steering) to stop the AD / ADAS driving support function		AMG	ACC AEB LKA	-	0 : Indefinite 1 : Not operate 2 : Operate init value:0
4		○	○			Driver requested acceleration	Driver required acceleration calculated from accelerator pedal operation	Indicates a positive value during acceleration	AMG	ACC AEB	m/s ²	init value:0
5			○			Driver request braking acceleration	Indicates the acceleration required by the driver brake operation	Indicates a negative value during deceleration	AMG	AEB	m/s ²	init value:0
6		○				Powertrain acceleration capability upper limit	Indicates the upper limit for the powertrain acceleration capability that can be realized as motion control	Defined as a value that can be realized within ** msec	AMG	ACC	m/s ²	init value:0
7		○				Powertrain acceleration capability lower limit	Indicates the lower limit for the powertrain acceleration capability that can be realized as motion control	Defined as a value that can be realized within ** msec	AMG	ACC	m/s ²	init value:0
9		○	○	○		PT system reliability information	Indicates the PT internal status required for coordinating the entire ADAS system		AMG	ACC AEB LKA	-	0: Initializing 1: Calibrating 2: Normal 3: Under protection control 4: Invalid (before confirmation) 5: Failure (confirmed) 6-F: Spare init value:0 *Handled as a set with the state transition diagram
10		○	○			BRK system reliability information	Indicates the BRK system internal status required for coordinating the entire ADAS system		AMG	ACC AEB	-	0: Initializing 1: Calibrating 2: Normal 3: Under protection control 4: Invalid (before confirmation) 5: Failure (confirmed) 6-F: Spare init value:0 *Handled as a set with the state transition diagram

Figure 6.4: PLN1, PLN2 (1)

No	Set	ACC	AEB	LKA	Type	Data name	Explanation	Supplementary information	Output source	Output dest.	Unit	Range of expressions
PLN2 (2)												
11			○	○		STR system reliability information	Indicates the STR internal status required for coordinating the entire ADAS system		AMG	AEB LKA	-	0: Initializing 1: Calibrating 2: Normal 3: Under protection control 4: Invalid (before confirmation) 5: Failure (confirmed) 6-F: Spare init value:0 *Handled as a set with the state transition diagram
12		○	○	○		Operation status of braking force stabilization process (longitudinal)	Indicates whether or not the braking force stabilization process is operating		AMG	ACC AEB LKA	-	0: Stopped 1: Operating init value:0
13		○				Operation status of driving force stabilization process	Indicates whether or not the driving force stabilization process is operating		AMG	ACC	-	0: Stopped 1: Operating init value:0
14		○	○	○		Operation status of steering force stabilization process	Indicates whether or not the steering force stabilization process is operating		AMG	ACC AEB LKA	-	0: Stopped 1: Operating init value:0
15		○	○	○		Actual shift range information	Indicates the current shift range calculated by the PT		AMG	ACC AEB LKA	-	0: Indefinite 1: P 2: R 3: N 4: D 5-7: Spare init value:0
16		○			PT status	Arbitration result of driving torque/force request	Indicates the arbitration result for the PT internal driver request and VMG request		AMG	ACC	-	0: Driver request selected 1: VMG request selected init value:0
17		○	○		BRK status	Arbitration result of braking torque	Indicates the arbitration result for the BRK internal driver request and VMG request		AMG	ACC AEB	-	0: Driver request selected 1: VMG request selected init value:0
18		○	○		BRK status	Status of vehicle standstill	The vehicle is on a standstill condition		AMG	ACC AEB	-	0 : Indefinite 1 : Stopped init value:0
19		○	○		BRK status	Standstill device information	Indicates operation status of standstill device		AMG	ACC AEB	-	0: Stopped 1: Operating init value:0
20		○	○		BRK status	Reliability information of standstill device	Indicates reliability information of standstill device		AMG	ACC AEB	-	0: Normal 1: Temporary failure 2: Failure (confirmed) init value:0
21				○	STR status	Driver's steering wheel holding status	Indicates whether or not the driver is holding the steering wheel (judgment simply of whether or not a person is holding)		AMG	LKA	-	0: Not holding steering wheel 1: Holding steering wheel 2: Indefinite init value:0
22			○	○	STR status	Driver's steering wheel operation torque	Indicates the strength of the torque when the driver operates the steering wheel	Counterclockwise direction is defined as positive	AMG	AEB LKA	Nm	init value:0
23			○	○	STR status	Steering wheel angle	Indicates the angle of the steering wheel	Counterclockwise direction is defined as positive	AMG	AEB LKA	rad	init value:0
24		○	○		PT status	Accelerator pedal ON/OFF information	Indicates whether or not the accelerator pedal is depressed		AMG	ACC AEB	-	0 : OFF 1 : ON init value:0
25		○			BRK status	Brake pedal ON/OFF information	Indicates whether or not the brake pedal is depressed		AMG	ACC	-	0 : OFF 1 : ON init value:0
26		○	○	○	Vehicle momentum	Estimated longitudinal acceleration (ground equivalent)	Indicates the estimated longitudinal acceleration equivalent to ground that is calculated by VMG	Acceleration is defined as positive	AMG	ACC AEB LKA	m/s ²	init value:0
27				○	Vehicle momentum	Estimated lateral acceleration	Indicates the estimated lateral acceleration equivalent to ground that is calculated by VMG	Counterclockwise direction is defined as positive	AMG	LKA	m/s ²	init value:0
28		○	○	○	Vehicle momentum	Estimated vehicle body speed	Indicates the estimated vehicle body speed that is calculated by VMG	Forward direction is defined as positive	AMG	ACC AEB LKA	m/s	init value:0
29				○	Vehicle momentum	Estimated yaw rate	Indicates the estimated yaw rate that is calculated by VMG	Counterclockwise direction is defined as positive	AMG	LKA	rad/s	init value:0
30		○		○	HMI	Meter display vehicle speed	Indicates the vehicle speed displayed on the meter	Forward direction is defined as positive	AMG	ACC LKA	m/s	init value:0
31		○	○	○	Vehicle momentum	Reliability information of estimated longitudinal acceleration	Indicates the estimated longitudinal acceleration required for coordinating the entire ADAS system		AMG	ACC AEB LKA	-	0: Initializing 1: Calibrating 2: Normal 4: Invalid (before confirmation) 5: Failure (confirmed) 6-F: Spare init value:0
32				○	Vehicle momentum	Reliability information of estimated lateral acceleration	Indicates the estimated lateral acceleration required for coordinating the entire ADAS system		AMG	LKA	-	0: Initializing 1: Calibrating 2: Normal 4: Invalid (before confirmation) 5: Failure (confirmed) 6-F: Spare init value:0
33		○	○	○	Vehicle momentum	Reliability information of estimated vehicle speed	Indicates the estimated vehicle speed required for coordinating the entire ADAS system		AMG	ACC AEB LKA	-	0: Initializing 1: Calibrating 2: Normal 4: Invalid (before confirmation) 5: Failure (confirmed) 6-F: Spare init value:0

Figure 6.5: PLN2 (2)

No	Set	ACC	AEB	LKA	Type	Data name	Explanation	Supplementary information	Output source	Output dest.	Unit	Range of expressions
PLN2 (3)												
34				○	Vehicle momentum	Reliability information of estimated yaw rate	Indicates the estimated yaw rate required for coordinating the entire ADAS system		AMG	LKA	-	0: Initializing 1: Calibrating 2: Normal 4: Invalid (before confirmation) 5: Failure (confirmed) 6-F: Spare init value:0
35		○		○	HMI	Reliability information of Meter display vehicle speed	Indicates the meter display vehicle speed required for coordinating the entire ADAS system		AMG	ACC LKA	-	0: Initializing 1: Calibrating 2: Normal 4: Invalid (before confirmation) 5: Failure (confirmed) 6-F: Spare init value:0
36				○	Vehicle momentum	Estimated curvature	Indicates the estimated vehicle path curvature equivalent to ground that is calculated by VMG	Curvature turning to the left is defined as positive	AMG	LKA	1/m	init value:0
37				○	Vehicle momentum	Reliability information of estimated curvature	Indicates the reliability of the estimated curvature required for coordinating the entire ADAS system		AMG	LKA	-	0: Initializing 1: Calibrating 2: Normal 4: Invalid (before confirmation) 5: Failure (confirmed) 6-F: Spare init value:0
38				○	Vehicle momentum	Realizable vehicle curvature - upper limit	Indicates the upper limit for the vehicle curvature that can be realized as motion control. This is mainly for trucks, for which following use cases are common. Example use case can be to capture changes in vehicle curvature capabilities due to factors like special actuators (rear axle steering), vehicle configuration (tractor only versus tractor with one or more trailers) or vehicle dynamic conditions (reduced rollover threshold for fully loaded truck versus unloaded truck), etc.	Defined as a value that can be realized within ** msec	AMG	LKA	1/m	init value:0
39				○	Vehicle momentum	Realizable vehicle curvature - lower limit	Indicates the lower limit for the vehicle curvature that can be realized as motion control. This is mainly for trucks, for which following use cases are common. Example use case can be to capture changes in vehicle curvature capabilities due to factors like special actuators (rear axle steering), vehicle configuration (tractor only versus tractor with one or more trailers) or vehicle dynamic conditions (reduced rollover threshold for fully loaded truck versus unloaded truck), etc.	Defined as a value that can be realized within ** msec	AMG	LKA	1/m	init value:0
VMC1												
1	VMC1-3	○	○		ACC request	AMG target acceleration for maximum selection	Indicates the AMG target acceleration assuming maximum selection with Driver requested acceleration		AMG	VMG	m/s ²	init value:0
2	VMC1-3	○	○		AEB request	AMG target acceleration for minimum selection	Indicates the AMG target acceleration assuming minimum selection with Driver requested acceleration		AMG	VMG	m/s ²	init value:0
3		○	○		ACC/AEB status	AMG target acceleration validity information	Indicates whether the AMG target acceleration is valid or invalid		AMG	VMG	-	0:Invalid 1:Valid init value:0
4		○			ACC status	ACC status	Indicates the ACC control status		AMG	VMG	-	0 : OFF 1 : STANDBY 2 : ON 7 : Vehicle stop hold init value:0
5		○			ACC request	ACC standstill control request	Indicates whether the ACC standstill control is requested or not		AMG	VMG	-	0: Not requested 1: Requested init value:0
6			○		AEB status	AEB status	Indicates the AEB control status		AMG	VMG	-	0:OFF 1: 2:ON (Standby) 3:Warning 4:Deceleration preparation (+ Warning) 5:Soft deceleration (+ Warning) 6:Strong deceleration (+ Warning) 7:Vehicle stop hold init value:0
7			○		AEB request	AEB standstill control request	Indicates whether the AEB standstill control is requested or not		AMG	VMG	-	0: Not requested 1: Requested init value:0
8	VMC1-9			○	LKA request	Target curvature after arbitration	Indicates the AMG target curvature		AMG	VMG	1/m	init value:0
9				○	LKA status	Target curvature validity information	Indicates whether the AMG target curvature is valid or invalid		AMG	VMG	-	0:Invalid 1:Valid init value:0
10				○	LKA status	LKA status	Indicates the LKA status		AMG	VMG	-	0 : OFF 1 : STANDBY 2 : ON init value:0

Figure 6.6: PLN2 (3), VMC1

No	Set	ACC	AEB	LKA	Type	Data name	Explanation	Supplementary information	Output source	Output dest.	Unit	Range of expressions
VMC2 (1)												
1		○			VMG limit	Powertrain acceleration capability upper limit	Indicates the upper limit for the powertrain acceleration capability that can be realized as motion control	Defined as a value that can be realized within ** msec	VMG	AMG ACC	m/s ²	init value:0
2		○			VMG limit	Powertrain acceleration capability lower limit	Indicates the lower limit for the powertrain acceleration capability that can be realized as motion control	Defined as a value that can be realized within ** msec	VMG	AMG ACC	m/s ²	init value:0
3		○			PT status	Driver requested acceleration	Driver required acceleration calculated from accelerator pedal operation		VMG	AMG	m/s ²	init value:0
4		○	○		PT status	PT system reliability information	Indicates the PT internal status required for coordinating the entire ADAS system		VMG	AMG ACC AEB	-	0: Initializing 1: Calibrating 2: Normal 3: Under protection control 4: Invalid (before confirmation) 5: Failure (confirmed) 6-F: Spare init value:0 *Handled as a set with the state transition diagram
5		○	○		PT status	Operation status of driving force stabilization process	Indicates whether or not the driving force stabilization process is operating		VMG	AMG ACC AEB	-	0: Stopped 1: Operating init value:0
6		○			PT status	Accelerator pedal ON/OFF information	Indicates whether or not the accelerator pedal is depressed		VMG	AMG ACC	-	init value:0
7		○			PT status	Arbitration result of driving torque/force request	Indicates the arbitration result for the PT internal driver request and VMG request		VMG	AMG ACC	-	0: Driver request selected 1: VMG request selected init value:0
8		○	○	○	PT status	Actual shift range information	Indicates the current shift range calculated by the PT		VMG	AMG ACC AEB LKA	-	0: Indefinite 1: P 2: R 3: N 4: D 5-7: Spare init value:0
9		○	○		BRK status	BRK system reliability information	Indicates the BRK system internal status required for coordinating the entire ADAS system		VMG	AMG ACC AEB	-	0: Initializing 1: Calibrating 2: Normal 3: Under protection control 4: Invalid (before confirmation) 5: Failure (confirmed) 6-F: Spare init value:0 *Handled as a set with the state transition diagram
10		○	○	○	BRK status	Operation status of braking force stabilization process	Indicates whether or not the braking force stabilization process is operating		VMG	AMG ACC AEB LKA	-	0: Stopped 1: Operating init value:0
11		○			BRK status	Brake pedal ON/OFF information	Indicates whether or not the brake pedal is depressed		VMG	AMG ACC	-	0: Brake pedal released (driver braking not requested) 1: Brake pedal depressed (driver braking requested) init value:0
12		○	○		BRK status	Arbitration result of braking torque	Indicates the arbitration result for the BRK internal driver request and VMG request		VMG	AMG ACC AEB	-	0: Driver request selected 1: VMG request selected init value:0
13			○		BRK status	Driver request braking acceleration	Indicates the acceleration requested by the driver's braking operation	Indicates a negative value during deceleration	VMG	AMG AEB	m/s ²	init value:0
14			○	○	STR status	STR system reliability information	Indicates the STR internal status required for coordinating the entire ADAS system		VMG	AMG AEB LKA	-	0: Initializing 1: Calibrating 2: Normal 3: Under protection control 4: Invalid (before confirmation) 5: Failure (confirmed) 6-F: Spare init value:0 *Handled as a set with the state transition diagram
15		○	○	○	STR status	Operation status of steering force stabilization process	Indicates whether or not the steering force stabilization process is operating		VMG	AMG LKA	-	0: Stopped 1: Operating init value:0
16				○	STR status	Driver's steering wheel holding status	Indicates whether or not the driver is holding the steering wheel (judgment simply of whether or not a person is holding)		VMG	AMG LKA	-	0: Not holding steering wheel 1: Holding steering wheel 2: Indefinite init value:0
17			○	○	STR status	Driver's steering wheel operation torque	Indicates the strength of the torque when the driver operates the steering wheel	Counterclockwise direction is defined as positive	VMG	AMG AEB LKA	Nm	init value:0
18			○	○	STR status	Steering wheel angle	Indicates the angle of the steering wheel	Counterclockwise direction is defined as positive	VMG	AMG AEB LKA	rad	init value:0
19	VMC2-24	○	○	○	Vehicle momentum	Estimated longitudinal acceleration (ground equivalent)	Indicates the estimated longitudinal acceleration equivalent to ground that is calculated by VMG	Acceleration is defined as positive	VMG	AMG	m/s ²	init value:0
20	VMC2-25			○	Vehicle momentum	Estimated lateral acceleration	Indicates the estimated lateral acceleration equivalent to ground that is calculated by VMG	Counterclockwise direction is defined as positive	VMG	AMG	m/s ²	init value:0
21	VMC2-26	○	○	○	Vehicle momentum	Estimated vehicle body speed	Indicates the estimated vehicle body speed that is calculated by VMG	Forward direction is defined as positive	VMG	AMG	m/s	init value:0
22	VMC2-27			○	Vehicle momentum	Estimated yaw rate	Indicates the estimated yaw rate that is calculated by VMG	Counterclockwise direction is defined as positive	VMG	AMG	rad/s	init value:0

Figure 6.7: VMC2 (1)

No	Set	ACC	AEB	LKA	Type	Data name	Explanation	Supplementary information	Output source	Output dest.	Unit	Range of expressions
VMC2 (2)												
23	VMC2-28	○			HMI	Meter display vehicle speed	Indicates the vehicle speed displayed on the meter	Forward direction is defined as positive	VMG	AMG	m/s	init value:0
24		○	○	○	Vehicle momentum	Reliability information of estimated longitudinal acceleration	Indicates the estimated longitudinal acceleration required for coordinating the entire ADAS system		VMG	AMG	-	0: Initializing 1: Calibrating 2: Normal 4: Invalid (before confirmation) 5: Failure (confirmed) 6-F: Spare init value:0
25				○	Vehicle momentum	Reliability information of estimated lateral acceleration	Indicates the estimated lateral acceleration required for coordinating the entire ADAS system		VMG	AMG	-	0: Initializing 1: Calibrating 2: Normal 4: Invalid (before confirmation) 5: Failure (confirmed) 6-F: Spare init value:0
26		○	○	○	Vehicle momentum	Reliability information of estimated vehicle speed	Indicates the estimated vehicle speed required for coordinating the entire ADAS system		VMG	AMG	-	0: Initializing 1: Calibrating 2: Normal 4: Invalid (before confirmation) 5: Failure (confirmed) 6-F: Spare init value:0
27				○	Vehicle momentum	Reliability information of estimated yaw rate	Indicates the estimated yaw rate required for coordinating the entire ADAS system		VMG	AMG	-	0: Initializing 1: Calibrating 2: Normal 4: Invalid (before confirmation) 5: Failure (confirmed) 6-F: Spare init value:0
28		○		○	HMI	Reliability information of Meter display vehicle speed	Indicates the meter display vehicle speed required for coordinating the entire ADAS system		VMG	AMG	-	0: Initializing 2: Normal 4: Invalid (before confirmation) 5: Failure (confirmed) 6-F: Spare init value:0
29		○	○		BRK status	Status of vehicle standstill	The vehicle is on a standstill condition		VMG	AMG	-	0: Indefinite 1: Stopped init value:0
30		○	○		BRK status	Standstill device information	Indicates operation status of standstill device		VMG	AMG	-	0: Stopped 1: Operating init value:0
31		○	○		BRK status	Reliability information of standstill device	Indicates reliability information of standstill device		VMG	AMG	-	0: Normal 1: Temporary failure 2: Failure (confirmed) init value:0
32				○	Vehicle momentum	Estimated curvature	Indicates the estimated vehicle path curvature equivalent to ground that is calculated by VMG	Curvature turning to the left is defined as positive	VMG	AMG LKA	1/m	init value:0
33				○	Vehicle momentum	Reliability information of estimated curvature	Indicates the reliability of the estimated curvature required for coordinating the entire ADAS system		VMG	AMG LKA	-	0: Initializing 1: Calibrating 2: Normal 4: Invalid (before confirmation) 5: Failure (confirmed) 6-F: Spare init value:0
34				○	Vehicle momentum	Realizable vehicle curvature - upper limit	Indicates the upper limit for the vehicle curvature that can be realized as motion control. This is mainly for trucks, for which following use cases are common. Example use case can be to capture changes in vehicle curvature capabilities due to factors like special actuators (rear axle steering), vehicle configuration (tractor only versus tractor with one or more trailers) or vehicle dynamic conditions (reduced rollover threshold for fully loaded truck versus unloaded truck), etc.	Defined as a value that can be realized within ** msec	VMG	AMG LKA	1/m	init value:0
35				○	Vehicle momentum	Realizable vehicle curvature - lower limit	Indicates the lower limit for the vehicle curvature that can be realized as motion control. This is mainly for trucks, for which following use cases are common. Example use case can be to capture changes in vehicle curvature capabilities due to factors like special actuators (rear axle steering), vehicle configuration (tractor only versus tractor with one or more trailers) or vehicle dynamic conditions (reduced rollover threshold for fully loaded truck versus unloaded truck), etc.	Defined as a value that can be realized within ** msec	VMG	AMG LKA	1/m	init value:0

Figure 6.8: VMC2 (2)

No	Set	ACC	AEB	LKA	Type	Data name	Explanation	Supplementary information	Output source	Output dest.	Unit	Range of expressions
ACL1												
1A		O			VMG request	Driving torque for Max selection	Indicates the drive shaft total driving torque requested of the PT, assuming the Max selection with the driver request driving torque		VMG	PT	Nm	init value:0
1B		O			VMG request	Driving force for Max selection	Indicates the drive shaft total driving force requested of the PT, assuming the Max selection with the driver request driving force		VMG	PT	N	init value:0
2A			O		VMG request	Driving torque for Min selection	Indicates the drive shaft total driving torque requested of the PT, assuming the Min selection with the driver request driving torque		VMG	PT	Nm	init value:0
2B			O		VMG request	Driving force for Min selection	Indicates the drive shaft total driving force requested of the PT, assuming the Min selection with the driver request driving force		VMG	PT	N	init value:0
3	ACL1-1	O			VMG request	Mode for PT Max selection	Indicates the signal for specifying the arbitration method for driver request driving torque and Max selection driving torque	The method of arbitration is the same as Max selection; when the request source Application is switched to the other, use the characteristics of Application information to optimize powertrain control, such as input step value or modulated value for control. → Characteristics of request Application ≙ mode	VMG	PT	-	0: Mode not requested 1: Mode request A 2: Mode request B ... 127: Mode request XX init value:0
4	ACL1-2		O		VMG request	Mode for PT Min selection	Indicates the signal for specifying the arbitration method for driver request driving torque and Min selection driving torque	The method of arbitration is the same as Min selection; when the request source Application is switched to the other, use the characteristics of Application information to optimize powertrain control, such as input step value or modulated value for control. → Characteristics of request Application ≙ mode	VMG	PT	-	0: Mode not requested 1: Mode request A 2: Mode request B ... 127: Mode request XX init value:0
ACL2 (1)												
1	ACL2-10 / ACL2-11	O			PT status	Driver accelerator pedal ON/OFF information	Indicates whether or not the accelerator pedal is depressed		PT	VMG	-	init value:0
2	ACL2-10 / ACL2-11	O			PT status	Driver accelerator pedal operation amount	Indicates how much the accelerator pedal is depressed		PT	VMG	%	init value:0
3A	ACL2-10 / ACL2-11	O			PT status	Driver request driving torque	Indicates the driving torque requested via the accelerator pedal	A negative value may occur when the accelerator pedal is OFF Negative value amount changes according to the gear ratio	PT	VMG	Nm	init value:0
3B	ACL2-10 / ACL2-11	O			PT status	Driver request driving force	Indicates the driving force requested via the accelerator pedal	A negative value may occur when the accelerator pedal is OFF Negative value amount changes according to the gear ratio	PT	VMG	N	init value:0
4	ACL2-10 / ACL2-11	O			PT status	Selection result of Drive request in PT	Indicates the selection result for the PT internal driver request and VMG request However, note that since the selection result also includes correction values within the powertrain, this does not necessarily indicate which of the driver request or VMG request is selected	When there is no driving request from VMG, set as "Driver request selected". The signal is used to secure drivability by adding powertrain status and performing FB control of requested values on VMG side. (Also used for driving force estimated values)	PT	VMG	-	0: Driver request selected 1: VMG request selected init value:0
5A	ACL2-10 / ACL2-11	O			PT status	PT actual driving torque	Indicates the current drive shaft total driving torque calculated by the PT	A negative value may occur Negative value amount changes according to the gear ratio	PT	VMG	Nm	init value:0
5B	ACL2-10 / ACL2-11	O			PT status	PT actual driving force	Indicates the current drive shaft total driving force calculated by the PT	A negative value may occur Negative value amount changes according to the gear ratio	PT	VMG	N	init value:0
6	ACL2-10 / ACL2-11	O			PT status	Actual shift range information	Indicates the current shift range calculated by the PT		PT	VMG	-	0: Indefinite 1: P 2: R 3: N 4: D 5-7: Spare init value:0
7	ACL2-10 / ACL2-11	O			PT status	Reliability information of transmission	Indicates the internal status of transmission system		PT	VMG	-	0: Initializing 1: Calibrating 2: Normal 4: Invalid (before confirmation) 5: Failure (confirmed) 6-F: Spare init value:0
8A	ACL2-10 / ACL2-11	O			PT limit	Realizable driving torque upper limit	Indicates the upper limit value for the drive shaft total driving torque that the PT can realize at the current gear ratio	Defined as a value that can be realized for the vehicle within ** msec of the PT receiving the request *Defined individually for **	PT	VMG	Nm	init value:0
8B	ACL2-10 / ACL2-11	O			PT limit	Realizable driving force upper limit	Indicates the upper limit value for the drive shaft total driving force that the PT can realize at the current gear ratio	Defined as a value that can be realized for the vehicle within ** msec of the PT receiving the request *Defined individually for **	PT	VMG	N	init value:0
9A	ACL2-10 / ACL2-11	O			PT limit	Realizable driving torque lower limit	Indicates the lower limit value for the drive shaft total driving torque that the PT can realize at the current gear ratio	Defined as a value that can be realized for the vehicle within ** msec of the PT receiving the request *Defined individually for **	PT	VMG	Nm	init value:0
9B	ACL2-10 / ACL2-11	O			PT limit	Realizable driving force lower limit	Indicates the lower limit value for the drive shaft total driving force that the PT can realize at the current gear ratio	Defined as a value that can be realized for the vehicle within ** msec of the PT receiving the request *Defined individually for **	PT	VMG	N	init value:0

Figure 6.9: ACL1, ACL2 (1)

No	Set	ACC	AEB	LKA	Type	Data name	Explanation	Supplementary information	Output source	Output dest.	Unit	Range of expressions
ACL2 (2)												
10		○	○		PT status	Reliability information of Power Source	Indicate the internal state of the Power Source needed to coordinate the entire ADAS system	The signals of ACL2-1 to ACL2-6, ACL2-8 to ACL2-9 and ACL12 must be made into signals that can be used by VMG	PT	VMG	-	0: Initializing 1: Calibrating 2: Normal 3: Under protection control 4: Invalid (before confirmation) 5: Failure (confirmed) 6-F: Spare init value:0 *Handled as a set with the state transition diagram
11		○	○		PT status	Reliability information of Drive Line	Indicates the internal status of drive system	4WD system, differential mechanism	PT	VMG	-	0: Initializing 1: Calibrating 2: Normal 3: Under protection control 4: Invalid (before confirmation) 5: Failure (confirmed) 6-F: Spare init value:0 *Handled as a set with the state transition diagram
12	ACL2-10 / ACL2-11	○	○		PT status	Operation status of driving force stabilization process	Indicates whether or not the driving force stabilization process is operating		PT	VMG	-	0: Stopped 1: Operating init value:0
BRK1												
1		○	○		VMG request	Braking torque for brake control	Indicates the braking torque requested of to the BRK, assuming the Min selection with the driver request braking torque		VMG	BRK	Nm	init value:0
2	BRK1-1	○	○		VMG request	Mode for brake control	Indicates the signal for specifying the arbitration method for driver request braking torque and Min selection braking torque	The method of arbitration is when the request source Application is switch to the other, use the characteristics of Application information to optimize brake control, such as input step value or modulated value for control. → Characteristics of request Application ⇨ mode	VMG	BRK	-	0: Mode not requested 1: Mode request A 2: Mode request B ... 127: Mode request XX init value:0
3			○		VMG request	Braking preparation request	Indicates the request for the status where braking can be applied immediately	Defined as a value that can be realized for the vehicle within ** msec of the BRK receiving the request *Defined individually for **	VMG	BRK	-	0: Not requested 1: Requested init value:0
4		○	○		VMG request	Vehicle stop hold request	Indicates whether the vehicle stop hold request is requested or not requested		VMG	BRK	-	0: Not requested 1: Requested init value:0
BRK2												
1	BRK2-5	○			BRK status	Brake pedal ON/OFF information	Indicates whether or not the brake pedal is depressed		BRK	VMG	-	0: Brake pedal released (driver braking not requested) 1: Brake pedal depressed (driver braking requested) init value:0
2	BRK2-5	○	○		BRK status	Driver braking request torque	Indicates the braking torque requested via the brake pedal		BRK	VMG	Nm	init value:0
3	BRK2-5	○	○		BRK status	Braking request torque after arbitration	Indicates the arbitration result for the BRK internal driver request and VMG request as the requested torque value		BRK	VMG	Nm	init value:0
4	BRK2-5	○	○		BRK status	Braking realized torque after arbitration	Indicates the current braking torque (estimated value) calculated by BRK		BRK	VMG	Nm	init value:0
5		○	○		BRK status	Brake system reliability information	Indicates the BRK internal status required for coordinating the entire ADAS system		BRK	VMG	-	0: Initializing 1: Calibrating 2: Normal 3: Under protection control 4: Invalid (before confirmation) 5: Failure (confirmed) 6-F: Spare init value:0
6	BRK2-5	○	○	○	BRK status	Operation status of braking force stabilization process (longitudinal)	Indicates whether or not the braking force stabilization process is operating		BRK	VMG	-	0: Stopped 1: Operating init value:0
7	BRK2-8	○	○		BRK status	Standstill device information	Indicates operation status of standstill device		BRK	VMG	-	0: Stopped 1: Operating init value:0
8		○	○		BRK status	Reliability information of standstill device	Indicates reliability information of standstill device		BRK	VMG	-	0: Normal 1: Temporary failure 2: Failure (confirmed) init value:0
STR1												
1				○	VMG request	Target steering wheel angle	Indicates the target steering wheel angle for the ADAS system	Counterclockwise direction is defined as positive	VMG	STR	rad	init value:0
2				○	VMG request	Steering wheel angle control mode	Indicates whether the target steering wheel angle is valid or invalid.		VMG	STR	-	0: Control not requested 1: Control requested 2-7: ** init value:0
3				○	VMG request	Steering wheel upper and lower limit torque	Indicates the upper and lower limit torque (heaviness of steering wheel operation) for steering wheel operation assist	Differs according to ADAS Application	VMG	STR	Nm	init value:0

Figure 6.10: ACL2 (2), BRK1, BRK2, STR1

No	Set	ACC	AEB	LKA	Type	Data name	Explanation	Supplementary information	Output source	Output dest.	Unit	Range of expressions
STR2												
1			○	○	STR status	STR system reliability information	Indicates the STR internal status required for coordinating the entire ADAS system		STR	VMG	-	0: Initializing 1: Calibrating 2: Normal 3: Under protection control 4: Invalid (before confirmation) 5: Failure (confirmed) 6-F: Spare init value:0 *Handled as a set with the state transition diagram
2	STR2-1	○	○	○	STR status	Operation status of steering force stabilization process	Indicates whether or not the steering force stabilization process is operating		STR	VMG	-	0: Stopped 1: Operating init value:0
3	STR2-1			○	STR status	Driver's steering wheel holding status	Indicates whether or not the driver is holding the steering wheel (judgment simply of whether or not a person is holding)		STR	VMG	-	0: Not holding steering wheel 1: Holding steering wheel 2: Indefinite init value:0
4	STR2-1		○	○	STR status	Driver's steering wheel operation torque	Indicates the strength of the torque when the driver operates the steering wheel	Counterclockwise direction is defined as positive	STR	VMG	Nm	init value:0
5	STR2-1		○	○	STR status	Steering wheel angle	Indicates the angle of the steering wheel	Counterclockwise direction is defined as positive	STR	VMG	rad	init value:0
VSS2												
1	VSS2-5	○	○	○	Vehicle sensor value	Longitudinal G sensor value	Indicates the input from the longitudinal acceleration sensor	Acceleration side is defined as positive	Vehicle sensor	VMG	m/s ²	init value:0
2	VSS2-6			○	Vehicle sensor value	Lateral G sensor value	Indicates the input from the lateral acceleration sensor	Counterclockwise direction is defined as positive	Vehicle sensor	VMG	m/s ²	init value:0
3	VSS2-7	○	○	○	Vehicle sensor value	Wheel speed sensor values	Indicates the input from the wheel speed sensors	Forward direction is defined as positive	Vehicle sensor	VMG	m/s	init value:0
4	VSS2-8			○	Vehicle sensor value	Yaw rate sensor value	Indicates the input from the yaw rate sensor	Counterclockwise direction is defined as positive	Vehicle sensor	VMG	rad/s	init value:0
5		○	○	○	Vehicle sensor value	Longitudinal G sensor reliability information	Indicates the longitudinal G sensor status required for coordinating the entire ADAS system		Vehicle sensor	VMG	-	0: Initializing 2: Normal 4: Invalid (before confirmation) 5: Failure (confirmed) 6-F: Spare init value:0
6				○	Vehicle sensor value	Lateral G sensor reliability information	Indicates the lateral G sensor status required for coordinating the entire ADAS system		Vehicle sensor	VMG	-	0: Initializing 2: Normal 4: Invalid (before confirmation) 5: Failure (confirmed) 6-F: Spare init value:0
7		○	○	○	Vehicle sensor value	Wheel speed sensor reliability information	Indicates the wheel speed sensor status required for coordinating the entire ADAS system		Vehicle sensor	VMG	-	0: Initializing 2: Normal 4: Invalid (before confirmation) 5: Failure (confirmed) 6-F: Spare init value:0
8				○	Vehicle sensor value	Yaw rate sensor reliability information	Indicates the yaw rate sensor status required for coordinating the entire ADAS system		Vehicle sensor	VMG	-	0: Initializing 2: Normal 4: Invalid (before confirmation) 5: Failure (confirmed) 6-F: Spare init value:0

Figure 6.11: STR2, VSS2