

<b>Document Title</b>	Specification of Vehicle-2-X Management
<b>Document Owner</b>	AUTOSAR
<b>Document Responsibility</b>	AUTOSAR
<b>Document Identification No</b>	796

<b>Document Status</b>	published
<b>Part of AUTOSAR Standard</b>	Classic Platform
<b>Part of Standard Release</b>	R21-11

<b>Document Change History</b>			
<b>Date</b>	<b>Release</b>	<b>Changed by</b>	<b>Change Description</b>
2021-11-25	R21-11	AUTOSAR Release Management	<ul style="list-style-type: none"> <li>Return codes and error reporting added</li> </ul>
2020-11-30	R20-11	AUTOSAR Release Management	<ul style="list-style-type: none"> <li>Editorial changes</li> </ul>
2019-11-28	R19-11	AUTOSAR Release Management	<ul style="list-style-type: none"> <li>Update referenced Documents</li> <li>Editorial changes</li> <li>Changed Document Status from Final to published</li> </ul>
2018-10-31	4.4.0	AUTOSAR Release Management	<ul style="list-style-type: none"> <li>Header file clean-up</li> <li>Fixed position and time parameter names</li> <li>Editorial changes</li> </ul>
2017-12-08	4.3.1	AUTOSAR Release Management	<ul style="list-style-type: none"> <li>Editorial changes</li> </ul>
2016-11-30	4.3.0	AUTOSAR Release Management	<ul style="list-style-type: none"> <li>Initial Release</li> </ul>

## Disclaimer

This work (specification and/or software implementation) and the material contained in it, as released by AUTOSAR, is for the purpose of information only. AUTOSAR and the companies that have contributed to it shall not be liable for any use of the work.

The material contained in this work is protected by copyright and other types of intellectual property rights. The commercial exploitation of the material contained in this work requires a license to such intellectual property rights.

This work may be utilized or reproduced without any modification, in any form or by any means, for informational purposes only. For any other purpose, no part of the work may be utilized or reproduced, in any form or by any means, without permission in writing from the publisher.

The work has been developed for automotive applications only. It has neither been developed, nor tested for non-automotive applications.

The word AUTOSAR and the AUTOSAR logo are registered trademarks.

## Table of Contents

1	Introduction and functional overview .....	6
1.1	Architectural overview .....	6
1.2	Functional overview .....	6
1.2.1	Position and Time management (POTI) .....	7
1.2.2	Identity .....	7
1.2.3	Security .....	7
1.2.4	Decentralized Congestion Control (DCC) .....	7
2	Acronyms and abbreviations .....	8
3	Related documentation .....	9
3.1	Input documents .....	9
3.2	Related standards and norms .....	10
3.3	Related specification .....	10
4	Constraints and assumptions .....	11
4.1	Limitations .....	11
4.2	Applicability to car domains .....	11
4.3	Authorisation Tickets and Pseudonyms .....	11
5	Dependencies to other modules .....	12
5.1	AUTOSAR DET (Default Error Tracer) .....	12
5.2	AUTOSAR EcuM (Ecu State Manager) .....	12
5.3	AUTOSAR CSM (Cryptographic Service Manager) .....	12
5.4	AUTOSAR NvM (NVRAMManager) .....	12
5.5	AUTOSAR Math libraries (Mfl, Efx) .....	12
5.6	File structure .....	12
5.6.1	Code file structure .....	12
6	Requirements traceability .....	13
7	Functional specification .....	15
7.1	Startup behavior .....	15
7.2	Shutdown behavior .....	15
7.3	Identity management .....	15
7.4	Security .....	18
7.5	Position and Time .....	18
7.6	DCC Management .....	19
7.7	Error classification .....	20
7.7.1	Development Errors .....	20
7.7.2	Runtime Errors .....	20
7.7.3	Transient Faults .....	20
7.7.4	Production Errors .....	20
7.7.5	Extended Production Errors .....	21
8	API specification .....	22
8.1	Imported types .....	22
8.2	Type definitions .....	23

8.2.1	V2xM_ConfigType .....	23
8.2.2	V2x_GnPacketTransportType .....	23
8.2.3	V2x_GnDestinationType .....	24
8.2.4	V2x_GnAddressType .....	24
8.2.5	V2x_GnAreaShapeType .....	24
8.2.6	V2x_GnDestinationAreaType .....	25
8.2.7	V2x_GnTxResultType .....	25
8.2.8	V2x_SecProfileType .....	26
8.2.9	V2x_SecReturnTypes .....	27
8.2.10	V2x_MaximumPacketLifetimeType .....	27
8.2.11	V2x_TrafficClassIdType .....	27
8.2.12	V2x_ChanType .....	28
8.2.13	V2x_GnUpperProtocolType .....	28
8.2.14	V2x_GnLongPositionVectorType .....	29
8.2.15	V2x_PseudonymType .....	30
8.3	Function definitions .....	30
8.3.1	V2xM_Init .....	30
8.3.2	V2xM_GetVersionInfo .....	31
8.3.3	V2xM_GetPositionAndTime .....	31
8.3.4	V2xM_GetRefTimePtr .....	32
8.3.5	V2xM_V2xGn_ReqEncap .....	33
8.3.6	V2xM_V2xGn_ReqDecap .....	34
8.3.7	V2xM_TriggerPseudonymChange .....	37
8.3.8	V2xM_LockPseudonymChange .....	37
8.3.9	V2xM_UnlockPseudonymChange .....	38
8.3.10	V2xM_V2xGn_SetGlobalRxParams .....	39
8.3.11	V2xM_V2xGn_GetGlobalTxParams .....	40
8.3.12	V2xM_CalcDistance .....	41
8.3.13	V2xM_CalcHeadingInTolerance .....	42
8.3.14	V2xM_SetTollingZoneInformation .....	43
8.4	Call-back notifications .....	44
8.4.1	CSM callback interfaces .....	44
8.5	Scheduled functions .....	44
8.5.1	V2xM_MainFunction .....	44
8.6	Expected Interfaces .....	45
8.6.1	Mandatory Interfaces .....	45
8.6.2	Optional Interfaces .....	47
8.7	Service Interfaces .....	48
8.7.1	Client-Server-Interfaces .....	48
8.7.2	Implementation Data Types .....	54
8.7.3	Ports .....	56
9	Sequence diagrams .....	58
9.1	V2xM_Init – Time initialization .....	58
9.2	Position and time update V2xGn .....	59
9.3	Position and time update V2xFac .....	60
9.4	Time handling at reception .....	60
9.5	Initialization of Wireless Drivers .....	60
10	Configuration specification .....	62
10.1	Containers and configuration parameters .....	62

10.1.1	Variants .....	62
10.1.2	V2xM .....	62
10.1.3	V2xMConfig.....	62
10.1.4	V2xMSecurityConfig .....	63
10.1.5	V2xMGeneral .....	64
11	Not applicable requirements .....	67

# 1 Introduction and functional overview

This document specifies the functionality, API and the configuration of the AUTOSAR Basic Software module Vehicle-2-X Management (V2xM). The Vehicle-2-X Management module together with the Vehicle-2-X Facilities (V2xFac), Vehicle-2-X Basic Transport Protocol (V2xBtp), the Vehicle-2-X GeoNetworking (V2xGn) and the communication driver layer forms the V2X stack within the AUTOSAR architecture.

V2xM is designed to be hardware independent. It controls and supports the services of V2X protocol stack entities.

Note that figures in this document are not regarded as requirements.

## 1.1 Architectural overview

The position of the V2xM module within the Layered Software Architecture is shown below.

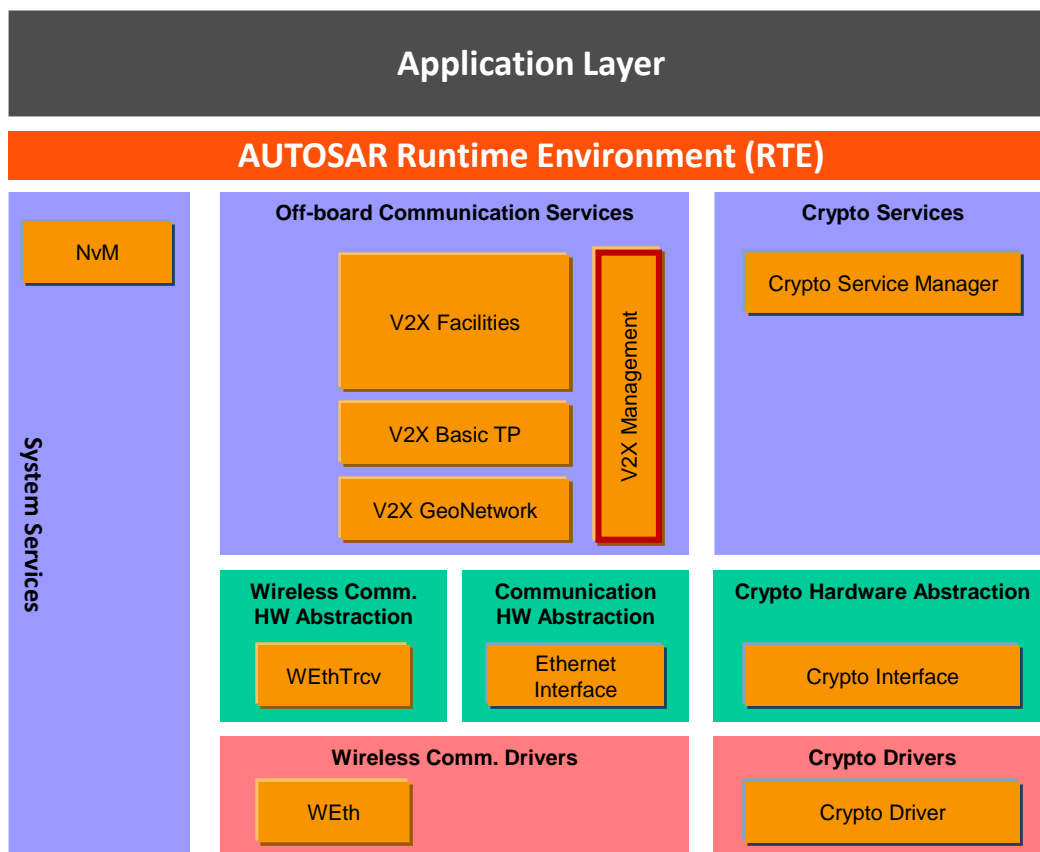

Figure 1-1 – AUTOSAR BSW architecture - V2xM scope

## 1.2 Functional overview

The V2xM module manages the operation of the V2X protocol stack. It does support the V2X protocol stack modules with a number of services and furthermore provide

some Application interfaces to let applications control the V2X-Stack within the limited range that the ETSI/C2C-CC Requirements left for applications..

### **1.2.1 Position and Time management (POTI)**

Within the AUTOSAR architecture, the POTI service is a V2X Application within the Application layer. The V2xM module takes positional information from the POTI service and makes it available to the V2xFac and V2xGn modules [6].

### **1.2.2 Identity**

A V2X Station has one identity that is used by every V2X module, that uses identity in its header information. For security and privacy reasons, the identity changes over time and travel distance. All modules that are using the identity shall be notified.

### **1.2.3 Security**

V2xM provides standardized security services to the V2X-Stack according to ETSI specification, this includes signing and verification of messages as described in [7]. The APIs shall be implemented using CSM services provided by AUTOSAR.

### **1.2.4 Decentralized Congestion Control (DCC)**

V2xM provides congestion control services for the V2X Stack, to provide the current V2X radio congestion state for a specific channel.

## 2 Acronyms and abbreviations

<b>Abbreviation / Acronym:</b>	<b>Description:</b>
DEM	Diagnostic Event Manager
DET	Default Error Tracer
API	Application Programming Interface
BSW	Basic Software
BTP	Basic Transport Protocol
CAM	Cooperative Awareness Message
DCC	Decentralized Congestion Control
DENM	Decentralized Environmental Notification Messages
EcuM	Electronic Control Unit Manager
ITS	Intelligent Transport System
LTC	Long Term Certificate
POTI	Position and Time management
VOD	Verification on Demand
hashedID8	Calculated by first computing the SHA 256 hash of the Authorisation Ticket, and then taking the least significant eight bytes from the hash output
ECDSA	Elliptic Curve Digital Signature Algorithm



### 3 Related documentation

#### 3.1 Input documents

- [1] AUTOSAR Layered Software Architecture  
AUTOSAR\_EXP\_LayeredSoftwareArchitecture.pdf
- [2] AUTOSAR General Requirements on Basic Software Modules  
AUTOSAR\_SRS\_BSWGeneral.pdf
- [3] AUTOSAR General Specification for Basic Software Modules  
AUTOSAR\_SWS\_BSWGeneral.pdf
- [4] Glossary  
AUTOSAR\_TR\_Glossary
- [5] Intelligent Transport Systems (ITS); Communications Architecture  
ETSI EN 302 665 V1.1.1 (2010-09)
- [6] Intelligent Transport System (ITS); Facilities layer function;  
Part 3: Position and time facility specification"  
ETSI TS 102 890-3
- [7] Intelligent Transport Systems (ITS); OSI cross-layer topics; Part 8: Interface  
between security entity and network and transport layer  
ETSI TS 102 723-8
- [8] Specification of Default Error Tracer  
AUTOSAR\_SWS\_DefaultErrorTracer.pdf
- [9] Specification of ECU State Manager  
AUTOSAR\_SWS\_ECUStateManager.pdf
- [10] Specification of Module Vehicle-2-X Facilities  
AUTOSAR\_SWS\_V2XFacilities.pdf
- [11] Specification of Module Vehicle-2-X Basic Transport  
AUTOSAR\_SWS\_V2XBasicTransport.pdf
- [12] Specification of Ethernet Interface  
AUTOSAR\_SWS\_EthernetInterface.pdf
- [13] Specification of Crypto Service Manager  
AUTOSAR\_SWS\_CryptoServiceManager.pdf
- [14] Specification of Vehicle-2-X Geo Networking  
AUTOSAR\_SWS\_V2XGeoNetworking.pdf
- [15] Specification of Vehicle-2-X Facilities  
AUTOSAR\_SWS\_V2XFacilities.pdf

- [16] Specification of Vehicle-2-X Basic Transport  
AUTOSAR\_SWS\_V2XBasicTransport.pdf
- [17] Specification of Module NVRAM Manager  
AUTOSAR\_SWS\_NVRAMManager.pdf
- [18] Certificate Policy for Deployment and Operation of European Cooperative  
Intelligent Transport Systems (C-ITS), Release 1.1 June 2018
- [19] Security Policy & Governance Framework for Deployment and Operation of  
European Cooperative Intelligent Transport Systems (C-ITS), Release 1  
December 2017

### **3.2 Related standards and norms**

- [20] IEC 7498-1 The Basic Model, IEC Norm, 1994
- [21] ETSI TS 103 097 V1.3.1 (2017-10)
- [22] C2C-CC BSP Requirement  
C2CCC\_RS\_2037\_BSP\_Requirements.docx
- [23] ETSI TS 102 894-2 V1.3.1 (2018-08)
- [24] ETSI EN 302 637-2 V1.4.1 (2019-04)
- [25] ETSI EN 302 636-4-1 V1.3.1 (2017-08)
- [26] ETSI EN 302 663 – V1.2.1 (2013-07)
- [27] ETSI TS 102 723-8 V1.1.1 (2016-04)
- [28] ETSI TS 102 687 v1.2.1 (2018-04)
- [29] ETSI EN 302 571 V2.1.1 (2017-02)

### **3.3 Related specification**

AUTOSAR provides a General Specification on Basic Software (SWS BSW General) [3] which is also valid for V2xM.

Thus, the specification SWS BSW General [3] shall be considered as additional and required specification for V2xM.

## **4 Constraints and assumptions**

### **4.1 Limitations**

No limitations.

### **4.2 Applicability to car domains**

This specification is applicable to all car domains.

### **4.3 Authorisation Tickets and Pseudonyms**

The Authorisation Ticket (AT) is referred to as Pseudonym in this document.

## 5 Dependencies to other modules

This section describes the relations of the V2xM module to other modules within the AUTOSAR basic software architecture. It outlines the modules that are required or optional for the realization of the V2xM module and the V2xM services that these modules use.

### 5.1 AUTOSAR DET (Default Error Tracer)

In development mode, the V2xM module reports errors through the `Det_ReportError` function of the DET Module, [8].

### 5.2 AUTOSAR EcuM (Ecu State Manager)

The EcuM [9] initializes the V2xM module.

### 5.3 AUTOSAR CSM (Cryptographic Service Manager)

The CSM module is used for cryptographic calculations, needed by the V2X-Stack to secure packets. Therefore, sign and verify and other services of the CSM are being used.

### 5.4 AUTOSAR NvM (NVRAMManager)

The NvM [17] is used by V2xM to load certificates used for pseudonyms, signature generation and verification of V2X messages. Furthermore, the last ignition-time (startup-time of the v2x stack) is stored and loaded by NvM.

### 5.5 AUTOSAR Math libraries (Mfl, Efx)

For mathematical calculations, the Mfl or the Efx library is needed.

### 5.6 File structure

#### 5.6.1 Code file structure

For details refer to the chapter 5.1.6 “Code file structure” in *SWS\_BSWGeneral* [3].

## 6 Requirements traceability

### Note:

Requirement IDs within this document have an encoding to state where each requirement has its origin:

- SWS items starting with a leading 0 (SWS\_V2xM\_0xxxx) are module specific and not inherited.
- SWS items starting with a leading 2 (SWS\_V2xM\_2xxxx) are inherited from C2C-CC Basic System Profile

Requirement	Description	Satisfied by
SRS_BSW_00345	BSW Modules shall support pre-compile configuration	SWS_V2xM_00191
SRS_BSW_00414	Init functions shall have a pointer to a configuration structure as single parameter	SWS_V2xM_00118
SRS_BSW_00457	Callback functions of Application software components shall be invoked by the Basis SW	SWS_V2xM_00163
SRS_V2X_00010	The implementation of the V2X system shall follow additional guidance given by C2C-CC requirements	SWS_V2xM_20182, SWS_V2xM_20183, SWS_V2xM_20191, SWS_V2xM_20192
SRS_V2X_00163	The "verification" of a message shall comprise at least cryptographic verification of the message's signature	SWS_V2xM_00130, SWS_V2xM_00199, SWS_V2xM_20170
SRS_V2X_00174	The V2X system shall support key origin authentication for the new (long-term or pseudonym) public keys that are provided in certificate signing requests	SWS_V2xM_00199, SWS_V2xM_00200, SWS_V2xM_20180, SWS_V2xM_20411
SRS_V2X_00176	The V2X system shall change pseudonyms	SWS_V2xM_00201
SRS_V2X_00184	The V2X system shall allow applications to block the pseudonym change	SWS_V2xM_00005, SWS_V2xM_00099
SRS_V2X_00190	The V2X system shall handle vehicle states in a consistent manner	SWS_V2xM_00095
SRS_V2X_00193	The V2X system shall use ITS time as time base	SWS_V2xM_00126
SRS_V2X_00279	The V2X system shall support circular, rectangular and ellipsoidal geographical areas	SWS_V2xM_00113
SRS_V2X_00280	The V2X system shall use high-accuracy methods to calculate the distance between two coordinates	SWS_V2xM_00176, SWS_V2xM_00177
SRS_V2X_00322	The V2X system shall provide services to avoid channel congestion of the shared media	SWS_V2xM_00188, SWS_V2xM_00189, SWS_V2xM_20238, SWS_V2xM_20240
SRS_V2X_00406	The end-to-end security envelope shall be generated depending on the message type	SWS_V2xM_00038, SWS_V2xM_00074, SWS_V2xM_00135

SRS_V2X_00407	The signature in the end-to-end security envelope shall be generated using a private key corresponding to a valid authorization ticket (pseudonym certificate)	SWS_V2xM_00074, SWS_V2xM_00135
SRS_V2X_00412	The V2X system shall inform the driver about the expiration of the pseudonym certificates	SWS_V2xM_00095
SRS_V2X_00413	The V2X system shall inform the driver about the expiration of the Long Term Certificates	SWS_V2xM_00095
SRS_V2X_00531	The V2X system's Networking Layer shall support addressing based on geographic coordinates	SWS_V2xM_00035
SRS_V2X_00711	The V2X system's CA basic service shall be compliant to ETSI Specification of Cooperative Awareness Basic Service	SWS_V2xM_20293
SRS_V2X_10101	The V2X system shall follow the recommendations of European Certificate Policy and of European Security Policy	SWS_V2xM_20177, SWS_V2xM_20179, SWS_V2xM_20402, SWS_V2xM_20409

## 7 Functional specification

### 7.1 Startup behavior

**[SWS\_V2xM\_00001]** [

The function V2xM\_Init (refer to chapter 8.3.1) of the V2xM shall initialize the internal states of the V2xM module.

] ()

**[SWS\_V2xM\_00196]** [

The function V2xM\_Init of the V2xM shall initialize the underlying MCAL/ECUAL modules WEth and WEthTrcv with a call to EthIf\_SetControllerMode with the respective configured EthIfController V2xMEthIfCtrlRef.

] ()

**[SWS\_V2xM\_00197]** [

The Ethernet State Manager (EthSm) shall not be involved in the startup of the wireless communication stack.

] ()

Note: See Figure 9-5 for the initialization of the wireless communication stack MCAL/ECUAL modules.

### 7.2 Shutdown behavior

**[SWS\_V2xM\_00198]** [

The Wireless Communication is active until the ECU hardware is being shut down or reset. There are no means to stop the Vehicle-2-X wireless communication in advance.

] ()

### 7.3 Identity management

**[SWS\_V2xM\_00004]** [

The V2xM module shall implement the identity management, also known as the pseudonym. Specific V2X modules shall be notified with the current identity to ensure a consistent value is used in each layer of the V2X Stack.

] ()

**[SWS\_V2xM\_20182]** [

The V2xM module shall change all addresses and identifiers of other layers transmitted over the wireless communication media (such as StationId in CAM/DENM, GeoNetworking Source Address, MAC Source Address) when the used pseudonym changes. Those changes are necessary to ensure the privacy of the user. ] (SRS\_V2X\_00010)

Note: In V2xFac, the identity is represented in the Station Id, in V2xGn the identity is represented in the GeoNetworking address, in the Wireless Ethernet Driver the identity is represented in the MAC address.

**[SWS\_V2xM\_20183] [**

All identifiers according to **[SWS\_V2xM\_20182]** (MAC Source Address, StationId in CAM/DENM, GN Source Address) shall be derived from the "Certificate digest" / "hashedId8". The required number of least significant bytes of the "Certificate digest" / "hashedId8" shall be used as respective identifier.

] **(SRS\_V2X\_00010)**

**[SWS\_V2xM\_00005] [**

The V2xM module shall provide a mechanism to permit V2X modules to inhibit the identity change for a duration of maximum 15 minutes (e.g. during DENM event) via an API call to V2xM\_LockPseudonymChange.

] **(SRS\_V2X\_00184)**

**[SWS\_V2xM\_00099] [**

The V2xM shall not inhibit an identity change when the pseudonym identity expires (i.e. when the certificate that provides the current pseudonym expires within the period where the identity change inhibit was requested). ] **(SRS\_V2X\_00184)**

**[SWS\_V2xM\_00006] [**

The function V2xM\_Init shall initialize the identity management and provide an initial identity to the V2X protocol stack modules. ] **( )**

**[SWS\_V2xM\_00201] [**

The V2xM identity management shall initiate a first change of pseudonym during the trip randomly in a range of 800 to 1500 meters from the start position.

The second pseudonym change shall be performed at least 800 m from the last pseudonym change and randomly within an additional interval of 2 to 6 minutes.

The third pseudonym change shall be performed after 15 kilometers  $\pm$  5 kilometers (randomly)

Further pseudonym changes shall be performed every further 30 kilometers  $\pm$  5 kilometers (randomly) ] **(SRS\_V2X\_00176)**

**[SWS\_V2xM\_20180] [**

V2xM shall use the pseudonym validity periods as defined by the Authorisation Authority (AA) in conformance to the rules of the Root Certification Authority (RCA). ] **(SRS\_V2X\_00174)**

**[SWS\_V2xM\_20411] [**

In case that an V2xM module has no valid pseudonym certificates for signing messages, it shall stop transmitting messages that use the security profiles specified in [19], clause 7.1.1, clause 7.1.2, and clause 7.1.3. ] **(SRS\_V2X\_00174)**

**[SWS\_V2xM\_00008] [**

The V2xM\_MainFunction shall be used to initiate a change of the identity. ] **( )**



Note: The V2xM\_MainFunction can also be used for software implementation specific execution of cyclic tasks.

**[SWS\_V2xM\_00100]** [

The V2xM shall initiate a change of the pseudonym within two phases. A first prepare phase and a second commit or abort phase. The second phase depends on the result of all called modules within the first phase. If the first phase was successful, the commit phase shall be initiated, if the first phase was unsuccessful, the abort phase shall be initiated. ] ( )

**[SWS\_V2xM\_00101]** [

In the prepare phase, the desired API <Module>\_PreparePseudonymChange() shall be called. ] ( )

**[SWS\_V2xM\_00102]** [

In the commit phase, the desired API <Module>\_CommitPseudonymChange() shall be called. ] ( )

**[SWS\_V2xM\_00103]** [

In the abort phase, the desired API <Module>\_AbortPseudonymChange() shall be called. ] ( )

**[SWS\_V2xM\_00104]** [

The modules that shall be notified with the two phase pseudonym change by V2xM are V2xGn and V2xFac. ] ( )

**[SWS\_V2xM\_00105]** [

The EthernetInterface and the Wireless Ethernet Driver do not support a two phase id change. Within the commit phase of the two phase pseudonym change, the API EthIf\_SetPhysAddr shall be called to initiate the pseudonym change within the Wireless Ethernet Driver. ] ( )

**[SWS\_V2xM\_00200]** [

The maximum amount of pseudonyms per week shall be 100. ] (SRS\_V2X\_00174)

**[SWS\_V2xM\_20177]** [

The pseudonym used by the V2xM module shall change every time when the vehicle's ignition is switched on except if the system gets restarted within a period of 10 minutes, the pseudonym shall not be changed. ] (SRS\_V2X\_10101)

**[SWS\_V2xM\_20409]** [

The pseudonym change after turning on ignition shall be performed within a grace period of 1 minute. ] (SRS\_V2X\_10101)

**[SWS\_V2xM\_20179]** [

Pseudonyms may be reused within their validity period. ] (SRS\_V2X\_10101)

**[SWS\_V2xM\_20402]** [

The pseudonym validity periods shall not be longer than one week + overlapping period. ] (SRS\_V2X\_10101)

## 7.4 Security

### [SWS\_V2xM\_00009] [

The V2xM module shall provide the Encap and Decap services required by V2xGn and Verification On Demand (VOD) by utilizing CSM.

] ( )

### [SWS\_V2xM\_00175] [

The V2xM shall disable CAM generation in case of unusable position (e.g. due to no position available, degenerated dead reckoning, time jitter/drift). This is done via a call to V2xFac\_V2xM\_SetCaBsOperation. ] ( )

### [SWS\_V2xM\_20170] [

The V2xM module shall use for sending messages digital signatures and certificates based on ECDSA that is specified in IEEE 1609.2 as mentioned in [19]. ]

(SRS\_V2X\_00163)

Note: Additionally, [18] requires implementation of the elliptic curve brainpool P256r1 to sign messages.

### [SWS\_V2xM\_00199] [

The V2xM module shall support key origin authentication via the creation of a signature over internally generated public key(s), where public keys for Enrolment Certificates shall be signed with the module private key and public keys for Pseudonym Certificates shall be signed with a previously registered Enrolment Certificates private key. ] (SRS\_V2X\_00163, SRS\_V2X\_00174)

Note: The "module private key" is a vehicle specific unique private key that could be generated randomly inside the HSM when the ECU is initialized in the first place

### [SWS\_V2xM\_00135] [

The function V2xM\_V2xGn\_ReqEncap shall encapsulate the payload of the GeoNetworking packet to be sent as defined in [27] and [19].] (SRS\_V2X\_00406, SRS\_V2X\_00407)

### [SWS\_V2xM\_00136] [

The function V2xM\_V2xGn\_ReqDecap shall decapsulate the payload of a received GeoNetworking packet as defined in [27] and [19].] ( )

### [SWS\_V2xM\_00130] [

The function V2xM\_V2xGn\_ReqDecap shall invoke CSM APIs for the verification of the data given by SecuredDataPtr ] (SRS\_V2X\_00163)

## 7.5 Position and Time

### [SWS\_V2xM\_20191] [

WGS 84 shall be used as the reference coordinate system as defined in [23].

Altitude information shall be interpreted as height above WGS84 Ellipsoid. ]

(SRS\_V2X\_00010)

**[SWS\_V2xM\_20192]** [

Heading shall be interpreted as the direction of the horizontal velocity vector. The starting point of the velocity vector shall be the ITS Vehicle Reference Point as defined in CAM specification [24] B.19 ] (SRS\_V2X\_00010)

**[SWS\_V2xM\_00121]** [

The function V2xM\_GetPositionAndTime shall provide the currently known position and time information. ] ( )

**[SWS\_V2xM\_00126]** [

The function V2xM\_GetRefTimePtr shall provide an address pointer to 32 bit data containing the current V2X Time, i.e. the TAI milliseconds from 2004-01-01 00:00:00.000 modulo  $2^{32}$ . ] (SRS\_V2X\_00193)

**[SWS\_V2xM\_00177]** [

The function V2xM\_CalcDistance shall calculate the distance between two geographical points. ] (SRS\_V2X\_00280)

**[SWS\_V2xM\_00179]** [

The function V2xM\_CalcHeadingTolerance shall calculate if the difference of two heading values are within a given tolerance value. ] ( )

## 7.6 DCC Management

**[SWS\_V2xM\_20240]** [

The V2xM module shall use the following smoothing function of channel busy ratio (CBR) values:

$$CBR_{new} = (CBR(n) + CBR(n-1)) / 2$$

Where 'n' and 'n-1' are respectively the current and previous CBR sampling period as defined in [29], and with CBR() function as also defined in [29].

] (SRS\_V2X\_00322)

**[SWS\_V2xM\_20238]** [

The V2xM module shall use the reactive DCC algorithm outlined in Clause 5.3 of [28].

State	CBR	Packet rate (R)	T <sub>off</sub>
Relaxed	< 30 %	20 Hz	50 ms
Active_1	30 % to 39 %	10 Hz	100 ms
Active_2	40 % to 49 %	5 Hz	200 ms
Active_3	50 % to 65 %	4 Hz	250 ms
Restricted	> 65 %	1 Hz	1000 ms

The table corresponds to Table A.2 in [28] with an average T<sub>on</sub> of 500 μs. ] (SRS\_V2X\_00322)

**[SWS\_V2xM\_20293]** [

The parameter T\_GenCam\_Dcc (see [24]) shall be set to the value of the minimum time between two transmissions, T~off~, as given by the DCC Mechanism (see SWS\_V2xM\_20238), and pushed to the V2xFac module via the V2xFac\_V2xM\_SetTGenCamDcc API. ] (SRS\_V2X\_00711)

**[SWS\_V2xM\_00188] [**

The current state (restrictive, active sub-state, relaxed, see [SWS\_V2xM\_20238]) shall be set periodically to the WEthTrcv Module to allow message bursts within the relaxed state. ] (SRS\_V2X\_00322)

**[SWS\_V2xM\_00189] [**

The current transmission interval (see [SWS\_V2xM\_20238]) shall be set periodically to the WEthTrcv Module to allow triggering of transmit queues. ] (SRS\_V2X\_00322)

## 7.7 Error classification

### 7.7.1 Development Errors

**[SWS\_V2xM\_00031][**

<i>Type of error</i>	<i>Related error code</i>	<i>Error value</i>
API service called with wrong parameter	V2XM_E_PARAM	0x01
API service called with invalid pointer	V2XM_E_PARAM_POINTER	0x02
V2xM initialization failed	V2XM_E_INIT_FAILED	0x03
API function called before the V2xM module has been fully initialized	V2XM_E_UNINIT	0x04

]()

### 7.7.2 Runtime Errors

There are no runtime errors.

### 7.7.3 Transient Faults

There are no transient faults.

### 7.7.4 Production Errors

There are no production errors.

### **7.7.5 Extended Production Errors**

There are no extended production errors.

## 8 API specification

### 8.1 Imported types

In this chapter all types included from the following modules are listed:

[SWS\_V2xM\_00033]

<i>Module</i>	<i>Header File</i>	<i>Imported Type</i>
Csm	Rte_Csm_Type.h	Crypto_OperationModeType
	Rte_Csm_Type.h	Crypto_VerifyResultType
Gpt	Gpt.h	Gpt_ChannelType
	Gpt.h	Gpt_PredefTimerType
	Gpt.h	Gpt_ValueType
NvM	Rte_NvM_Type.h	NvM_BlockIdType
	Rte_NvM_Type.h	NvM_RequestResultType
StbM	Rte_StbM_Type.h	StbM_SynchronizedTimeBaseType
	Rte_StbM_Type.h	StbM_TimeBaseStatusType
	Rte_StbM_Type.h	StbM_TimeStampExtendedType
	Rte_StbM_Type.h	StbM_TimeStampType
	Rte_StbM_Type.h	StbM_UserDataType
Std	Std_Types.h	Std_ReturnType
	Std_Types.h	Std_VersionInfoType
V2x_GeneralTypes	Rte_V2xM_Type.h	V2xM_PositionAndTimeType
	Rte_V2xM_Type.h	V2xM_SecReportType
	V2x_GeneralTypes.h	V2x_ChanType
	V2x_GeneralTypes.h	V2x_PseudonymType
	V2x_GeneralTypes.h	V2x_SecProfileType
	V2x_GeneralTypes.h	V2x_SecReturnType
WEthTrcv	WEth_GeneralTypes.h	WEthTrcv_GetChanRxParamIdType
	WEth_GeneralTypes.h	WEthTrcv_SetChanRxParamIdType
	WEth_GeneralTypes.h	WEthTrcv_SetChanTxParamIdType
	WEth_GeneralTypes.h	WEthTrcv_SetRadioParamIdType

]()

## 8.2 Type definitions

[SWS\_V2xM\_00107] [

V2xM.h shall include V2x\_GeneralTypes.h for the inclusion of general V2X type declarations. ] ()

### 8.2.1 V2xM\_ConfigType

[SWS\_V2xM\_00110][

<b>Name</b>	V2xM_ConfigType		
<b>Kind</b>	Structure		
<b>Elements</b>	implementation specific		
	<b>Type</b>	--	
	<b>Comment</b>	The content of the configuration data structure is implementation specific.	
<b>Description</b>	Configuration data structure of the V2xM module.		
<b>Available via</b>	V2xM.h		

]()

### 8.2.2 V2x\_GnPacketTransportType

[SWS\_V2xM\_00034][

<b>Name</b>	V2x_GnPacketTransportType		
<b>Kind</b>	Enumeration		
<b>Range</b>	V2X_GN_GEOUNICAST	0x00	--
	V2X_GN_GEOANYCAST	0x01	--
	V2X_GN_GEOBROADCAST	0x02	--
	V2X_GN_TSB	0x03	--
	V2X_GN_SHB	0x04	--
<b>Description</b>	Specifies the packet transport type for GeoNetworking packages. This is passed e.g. via V2xFac and V2xBtp for the transmit path.		
<b>Available via</b>	V2x_GeneralTypes.h		

]()

### 8.2.3 V2x\_GnDestinationType

[SWS\_V2xM\_00112][

<b>Name</b>	V2x_GnDestinationType		
<b>Kind</b>	Enumeration		
<b>Range</b>	V2X_GN_DESTINATION_ADDRESS	0x00	--
	V2X_GN_DESTINATION_AREA	0x01	--
<b>Description</b>	Specifies the destination type for GeoNetworking packages. This is passed e.g. via V2xFac and V2xBtp for the transmit path.		
<b>Available via</b>	V2x_GeneralTypes.h		

]()

### 8.2.4 V2x\_GnAddressType

[SWS\_V2xM\_00035][

<b>Name</b>	V2x_GnAddressType
<b>Kind</b>	Type
<b>Derived from</b>	uint64
<b>Description</b>	The GeoNetworking address.
<b>Available via</b>	V2x_GeneralTypes.h

](SRS\_V2X\_00531)

### 8.2.5 V2x\_GnAreaShapeType

[SWS\_V2xM\_00113][

<b>Name</b>	V2x_GnAreaShapeType		
<b>Kind</b>	Enumeration		
<b>Range</b>	V2X_GN_SHAPE_CIRCLE	0x00	--
	V2X_GN_SHAPE_RECT	0x01	--
	V2X_GN_SHAPE_ELLIPSE	0x02	--
<b>Description</b>	Specifies the shape type for GeoNetworking Areas.		



<b>Available via</b>	V2x_GeneralTypes.h
----------------------	--------------------

](SRS\_V2X\_00279)

## 8.2.6 V2x\_GnDestinationAreaType

[SWS\_V2xM\_00036]

<b>Name</b>	V2x_GnDestinationAreaType	
<b>Kind</b>	Structure	
<b>Elements</b>	latitude	
	<b>Type</b>	sint32
	<b>Comment</b>	Latitude [1/10 microdegree]
	longitude	
	<b>Type</b>	sint32
	<b>Comment</b>	Longitude [1/10 microdegree]
	distanceA	
	<b>Type</b>	uint16
	<b>Comment</b>	Distance a of the geometric shape [meters]
	distanceB	
	<b>Type</b>	uint16
	<b>Comment</b>	Distance b of the geometric shape [meters]
	angle	
	<b>Type</b>	uint16
	<b>Comment</b>	Angle of the geometric shape [degrees from North]
	shape	
<b>Type</b>	V2x_GnAreaShapeType	
<b>Comment</b>	Shape type of the geometric area	
<b>Description</b>	Definition of the GeoNetworking destination area	
<b>Available via</b>	V2x_GeneralTypes.h	

]()

## 8.2.7 V2x\_GnTxResultType

[SWS\_V2xM\_00114]

<b>Name</b>	V2x_GnTxResultType		
<b>Kind</b>	Enumeration		
<b>Range</b>	V2X_GNTX_ACCEPTED	--	GeoNetworking transmit has been accepted
	V2X_GNTX_E_MAXSDUSIZEOVFL	--	GeoNetworking transmit has been rejected due to maximum length exceedance
	V2X_GNTX_E_MAXPACKETLIFETIME	--	GeoNetworking transmit has been rejected due to maximum lifetime exceedance
	V2X_GNTX_E_TCID	--	GeoNetworking transmit has been rejected due to unsupported Traffic Class ID
	V2X_GNTX_E_MAXGEOAREASIZE	--	GeoNetworking transmit has been rejected due to GeoArea exceeds max size
	V2X_GNTX_E_UNSPECIFIED	--	GeoNetworking transmit has been rejected due to unspecified reasons
<b>Description</b>	The result code used to specify if a V2xGn_Transmit has been processed successfully.		
<b>Available via</b>	V2x_GeneralTypes.h		

]()

### 8.2.8 V2x\_SecProfileType

[SWS\_V2xM\_00038]

<b>Name</b>	V2x_SecProfileType		
<b>Kind</b>	Enumeration		
<b>Range</b>	V2X_SECPROF_CAM	--	Cam Security Profile
	V2X_SECPROF_DENM	--	Denm Security Profile
	V2X_SECPROF_OTHER_SIGNED	--	Security Profile for other message types that have to be signed
	V2X_SECPROF_OTHER_SIGNED_EXTERNAL	--	Security Profile for other message types that are signed externally
	V2X_SECPROF_OTHER_SIGNED_ENCRYPTED	--	Security Profile for other message types that have to be signed and encrypted
<b>Description</b>	Used to describe the security service invoked by V2xM		
<b>Available via</b>	V2x_GeneralTypes.h		

] (SRS\_V2X\_00406)

### 8.2.9 V2x\_SecReturnType

[SWS\_V2xM\_00115]

<b>Name</b>	V2x_SecReturnType		
<b>Kind</b>	Enumeration		
<b>Range</b>	V2X_E_OK	--	Return with success
	V2X_E_NOT_OK	--	Failure during operation
	V2X_E_UNVERIFIED	--	Message has not been verified. Used for VoD
	V2X_E_BUF_OVFL	--	Destination buffer too small for security operation data output
<b>Description</b>	Used for return values of security related functions		
<b>Available via</b>	V2x_GeneralTypes.h		

]()

### 8.2.10 V2x\_MaximumPacketLifetimeType

[SWS\_V2xM\_00039]

<b>Name</b>	V2x_MaximumPacketLifetimeType		
<b>Kind</b>	Type		
<b>Derived from</b>	uint16		
<b>Range</b>	0..6300	--	Valid values
	6301..uint16 Max Value	--	Invalid
<b>Description</b>	Specifies the maximum tolerable time (in seconds) a GeoNetworking packet can be buffered.		
<b>Available via</b>	V2x_GeneralTypes.h		

]()

### 8.2.11 V2x\_TrafficClassIdType

[SWS\_V2xM\_00043]

<b>Name</b>	V2x_TrafficClassIdType		
<b>Kind</b>	Type		
<b>Derived from</b>	uint8		

<b>Range</b>	0..63	--	Valid values
	64..uint8 Max Value	--	Invalid
<b>Description</b>	Requirements on packet transport coming from ITS Facilities layer		
<b>Available via</b>	V2x_GeneralTypes.h		

]()

### 8.2.12 V2x\_ChanType

[SWS\_V2xM\_00044]

<b>Name</b>	V2x_ChanType		
<b>Kind</b>	Enumeration		
<b>Range</b>	V2X_SCH4	172	Service channel 4
	V2X_SCH3	174	Service channel 3
	V2X_SCH1	176	Service channel 1
	V2X_SCH2	178	Service channel 2
	V2X_CCH	180	Control channel
<b>Description</b>	Specifies the channel type to use. Channels from ITS-G5A and ITS-G5B are used. Values matching IEEE 802.11-2012 channel numbers.		
<b>Available via</b>	V2x_GeneralTypes.h		

]()

### 8.2.13 V2x\_GnUpperProtocolType

[SWS\_V2xM\_00045]

<b>Name</b>	V2x_GnUpperProtocolType		
<b>Kind</b>	Enumeration		
<b>Range</b>	V2X_ANY	--	Unspecified
	V2X_BTPA	--	Transport protocol: BTP-A (for interactive packet transport).
	V2X_BTPB	--	Transport protocol: BTP-B (for non-interactive packet transport).
	V2X_IPV6	--	IPv6 header
<b>Description</b>	Specifies the GeoNetworking payload.		
<b>Available via</b>	V2x_GeneralTypes.h		

I()

### 8.2.14 V2x\_GnLongPositionVectorType

[SWS\_V2xM\_00046]

<b>Name</b>	V2x_GnLongPositionVectorType	
<b>Kind</b>	Structure	
<b>Elements</b>	gnAddress	
	<b>Type</b>	V2x_GnAddressType
	<b>Comment</b>	GeoNetworking Address
	timestamp	
	<b>Type</b>	uint32
	<b>Comment</b>	Timestamp [ms]
	latitude	
	<b>Type</b>	sint32
	<b>Comment</b>	Latitude [1/10 microdegree]
	longitude	
	<b>Type</b>	sint32
	<b>Comment</b>	Longitude [1/10 microdegree]
	pai	
	<b>Type</b>	boolean
	<b>Comment</b>	Positional accuracy indicator
	speed	
	<b>Type</b>	sint16
	<b>Comment</b>	Speed [1/100 m/s]
	heading	
	<b>Type</b>	uint16
<b>Comment</b>	Heading [1/10 degrees]	
<b>Description</b>	Position-related information as defined within [25] chapter 9.5.2.	
<b>Available via</b>	V2x_GeneralTypes.h	

I()

### 8.2.15 V2x\_PseudonymType

[SWS\_V2xM\_00057]

<b>Name</b>	V2x_PseudonymType
<b>Kind</b>	Type
<b>Derived from</b>	uint64
<b>Description</b>	Pseudonym, derived from Pseudonym Certificates. The pseudonym is distributed to different modules to support privacy within the V2X System to the outside world.
<b>Available via</b>	V2x_GeneralTypes.h

]()

## 8.3 Function definitions

This is a list of functions provided for upper layer modules and other V2X stack modules.

### 8.3.1 V2xM\_Init

[SWS\_V2xM\_00070]

<b>Service Name</b>	V2xM_Init	
<b>Syntax</b>	<pre>void V2xM_Init (     const void * CfgPtr )</pre>	
<b>Service ID [hex]</b>	0x01	
<b>Sync/Async</b>	Synchronous	
<b>Reentrancy</b>	Non Reentrant	
<b>Parameters (in)</b>	CfgPtr	ConfigPtr Pointer to the selected configuration set.
<b>Parameters (inout)</b>	None	
<b>Parameters (out)</b>	None	
<b>Return value</b>	None	
<b>Description</b>	Initializes the V2xM module.	
<b>Available via</b>	V2xM.h	

]()

[SWS\_V2xM\_00116] [

The function shall store the access to the configuration structure for subsequent API calls. ] ( )

**[SWS\_V2xM\_00118] [**

The Configuration pointer configPtr shall always have a NULL\_PTR value] (SRS\_BSW\_00414)

**8.3.2 V2xM\_GetVersionInfo**

**[SWS\_V2xM\_00071][**

<b>Service Name</b>	V2xM_GetVersionInfo	
<b>Syntax</b>	<pre>void V2xM_GetVersionInfo (     Std_VersionInfoType* VersionInfoPtr )</pre>	
<b>Service ID [hex]</b>	0x02	
<b>Sync/Async</b>	Synchronous	
<b>Reentrancy</b>	Reentrant	
<b>Parameters (in)</b>	VersionInfoPtr	Pointer to store the version information of this module.
<b>Parameters (inout)</b>	None	
<b>Parameters (out)</b>	None	
<b>Return value</b>	None	
<b>Description</b>	Provides the version information of this module.	
<b>Available via</b>	V2xM.h	

]()

**[SWS\_V2xM\_00120] [**

If development error detection is enabled: the function shall check the parameter VersionInfoPtr for being valid. If the check fails, the function shall raise the development error V2XM\_E\_PARAM\_POINTER. ] ( )

**8.3.3 V2xM\_GetPositionAndTime**

**[SWS\_V2xM\_00072][**

<b>Service Name</b>	V2xM_GetPositionAndTime	
<b>Syntax</b>	<pre>Std_ReturnType V2xM_GetPositionAndTime (     V2xM_PositionAndTimeType* Poti )</pre>	
<b>Service ID [hex]</b>	0x03	

<b>Sync/Async</b>	Synchronous	
<b>Reentrancy</b>	Reentrant	
<b>Parameters (in)</b>	None	
<b>Parameters (inout)</b>	None	
<b>Parameters (out)</b>	Poti	Current position and time information including positional error information.
<b>Return value</b>	Std_Return-Type	E_OK: request successful E_NOT_OK: Time and/or position not available.
<b>Description</b>	Provides the instantaneous position information.	
<b>Available via</b>	V2xM.h	

]()

#### [SWS\_V2xM\_00122]

If development error detection is enabled: the function shall check that the service V2xM\_Init was previously called. If the check fails, the function shall raise the development error V2XM\_E\_UNINIT. ]()

#### [SWS\_V2xM\_00123]

If development error detection is enabled: the function shall check the parameter Poti for being valid. If the check fails, the function shall raise the development error V2XM\_E\_PARAM\_POINTER. ]()

### 8.3.4 V2xM\_GetRefTimePtr

#### [SWS\_V2xM\_00125]

<b>Service Name</b>	V2xM_GetRefTimePtr	
<b>Syntax</b>	Std_ReturnType V2xM_GetRefTimePtr ( const uint32** RefTimePtr )	
<b>Service ID [hex]</b>	0x04	
<b>Sync/Async</b>	Synchronous	
<b>Reentrancy</b>	Non Reentrant	
<b>Parameters (in)</b>	None	
<b>Parameters (inout)</b>	None	
<b>Parameters (out)</b>	RefTimePtr	Pointer to the current time information.
<b>Return value</b>	Std_ReturnType	E_OK: request successful E_NOT_OK: request failed



<b>Description</b>	Provides a pointer to the time reference of the V2X-Stack.
<b>Available via</b>	V2xM.h

]()

**[SWS\_V2xM\_00127]** [

If development error detection is enabled: the function shall check that the service V2xM\_Init was previously called. If the check fails, the function shall raise the development error V2XM\_E\_UNINIT. ] ( )

**[SWS\_V2xM\_00128]** [

If development error detection is enabled: the function shall check the parameter RefTimePtr for being valid. If the check fails, the function shall raise the development error V2XM\_E\_PARAM\_POINTER. ] ( )

### 8.3.5 V2xM\_V2xGn\_ReqEncap

**[SWS\_V2xM\_00074]**[

<b>Service Name</b>	V2xM_V2xGn_ReqEncap	
<b>Syntax</b>	<pre>V2x_SecReturnType V2xM_V2xGn_ReqEncap (     uint16 TransactionId16,     V2x_SecProfileType SecProfile,     uint16 UnsecuredDataLength,     const uint8* UnsecuredDataPtr,     uint16* SecuredDataLength,     uint8* SecuredDataPtr )</pre>	
<b>Service ID [hex]</b>	0x06	
<b>Sync/Async</b>	Asynchronous	
<b>Reentrancy</b>	Non Reentrant	
<b>Parameters (in)</b>	Transaction Id16	The request identifier that the client can use to match the response
	SecProfile	The security profile to use for encapsulation
	Unsecured DataLength	The length of the data to use for encapsulation
	Unsecured DataPtr	The pointer to the data to use for encapsulation
<b>Parameters (inout)</b>	SecuredData Length	The length pointer containing the maximum length of secured data SecuredDataPtr at input direction. Shall contain the actual size of the secured data SecuredDataPtr at output direction.
	SecuredData Ptr	The pointer where the secured data shall be put.

<b>Parameters (out)</b>	None	
<b>Return value</b>	V2x_Sec- ReturnType	V2X_E_OK: request successful V2X_E_NOT_OK: request failed V2X_E_BUF_OVFL: SecuredDataLength is too small for security operation result data
<b>Description</b>	This function is called by the V2xGn to sign and/or encrypt a message. An asynchronous V2xGn_V2xM_EncapConfirmation call will be used to notify V2xGn of the result.	
<b>Available via</b>	V2xM_V2xGn.h	

](SRS\_V2X\_00406, SRS\_V2X\_00407)

#### [SWS\_V2xM\_00131]

If development error detection is enabled: the function shall check that the service V2xM\_Init was previously called. If the check fails, the function shall raise the development error V2XM\_E\_UNINIT otherwise (if DET is disabled) return V2X\_E\_NOT\_OK. ] ( )

#### [SWS\_V2xM\_00132]

If development error detection is enabled: the function shall check the parameter UnsecuredDataPtr for being valid. If the check fails, the function shall raise the development error V2XM\_E\_PARAM\_POINTER otherwise (if DET is disabled) return V2X\_E\_NOT\_OK. ] ( )

#### [SWS\_V2xM\_00133]

If development error detection is enabled: the function shall check the parameter SecuredDataLength for being valid. If the check fails, the function shall raise the development error V2XM\_E\_PARAM\_POINTER otherwise (if DET is disabled) return V2X\_E\_NOT\_OK. ] ( )

#### [SWS\_V2xM\_00134]

If development error detection is enabled: the function shall check the parameter SecuredDataPtr for being valid. If the check fails, the function shall raise the development error V2XM\_E\_PARAM\_POINTER otherwise (if DET is disabled) return V2X\_E\_NOT\_OK. ] ( )

### 8.3.6 V2xM\_V2xGn\_ReqDecap

#### [SWS\_V2xM\_00075]

<b>Service Name</b>	V2xM_V2xGn_ReqDecap
<b>Syntax</b>	V2x_SecReturnType V2xM_V2xGn_ReqDecap ( uint32 TransactionId32, uint16 SecuredDataLength, const uint8* SecuredDataPtr, uint16* UnsecuredDataLength, uint8* UnsecuredDataPtr, V2xM_SecReportType* SecReport,

	<pre>uint64* CertificateId, uint32* ItsAid, uint8* SspLength, uint8* SspBits )</pre>	
<b>Service ID [hex]</b>	0x07	
<b>Sync/Async</b>	Asynchronous	
<b>Reentrancy</b>	Non Reentrant	
<b>Parameters (in)</b>	Transaction Id32	Transaction Id of the received Packet
	SecuredData Length	The length of the data to decrypt and verify
	SecuredData Ptr	The pointer to the data to decrypt and verify
<b>Parameters (inout)</b>	Unsecured DataLength	The pointer to the data length of the unsecured data. Shall contain the maximum available length (incoming direction) and the actual used length (outgoing direction)
	Unsecured DataPtr	The pointer where the decrypted /verified data shall be put
	SecReport	The security report.
	CertificateId	The identification of the used for verification (by certificate hash)
	ItsAid	The numerical value of the ITS-AID
	SspLength	The length (in octets, up to 31) of the SSP bits
	SspBits	The SSP bits
<b>Parameters (out)</b>	None	
<b>Return value</b>	V2x_Sec-Return Type	V2X_E_OK: request successful V2X_E_NOT_OK: request failed V2X_E_UNVERIFIEDED: VOD is being used V2X_E_BUF_OVFL: UnsecuredDataLength is too small for security operation result data
<b>Description</b>	This function is called by the V2xGn to decrypt and verify a message. An asynchronous V2xGn_V2xM_DecapConfirmation call will be used to notify V2xGn of the result.	
<b>Available via</b>	V2xM_V2xGn.h	

10)

**[SWS\_V2xM\_00137]**

If development error detection is enabled: the function shall check that the service V2xM\_Init was previously called. If the check fails, the function shall raise the

development error V2XM\_E\_UNINIT otherwise (if DET is disabled) return  
V2X\_E\_NOT\_OK. ] ( )

**[SWS\_V2xM\_00138]** [

If development error detection is enabled: the function shall check the parameter SecuredDataPtr for being valid. If the check fails, the function shall raise the development error V2XM\_E\_PARAM\_POINTER otherwise (if DET is disabled) return V2X\_E\_NOT\_OK. ] ( )

**[SWS\_V2xM\_00139]** [

If development error detection is enabled: the function shall check the parameter UnsecuredDataLength for being valid. If the check fails, the function shall raise the development error V2XM\_E\_PARAM\_POINTER otherwise (if DET is disabled) return V2X\_E\_NOT\_OK. ] ( )

**[SWS\_V2xM\_00140]** [

If development error detection is enabled: the function shall check the parameter UnsecuredDataPtr for being valid. If the check fails, the function shall raise the development error V2XM\_E\_PARAM\_POINTER otherwise (if DET is disabled) return V2X\_E\_NOT\_OK. ] ( )

**[SWS\_V2xM\_00183]** [

If development error detection is enabled: the function shall check the parameter SecReport for being valid. If the check fails, the function shall raise the development error V2XM\_E\_PARAM\_POINTER otherwise (if DET is disabled) return V2X\_E\_NOT\_OK. ] ( )

**[SWS\_V2xM\_00184]** [

If development error detection is enabled: the function shall check the parameter Certificateld for being valid. If the check fails, the function shall raise the development error V2XM\_E\_PARAM\_POINTER otherwise (if DET is disabled) return V2X\_E\_NOT\_OK. ] ( )

**[SWS\_V2xM\_00185]** [

If development error detection is enabled: the function shall check the parameter ItsAid for being valid. If the check fails, the function shall raise the development error V2XM\_E\_PARAM\_POINTER otherwise (if DET is disabled) return V2X\_E\_NOT\_OK. ] ( )

**[SWS\_V2xM\_00186]** [

If development error detection is enabled: the function shall check the parameter SspLength for being valid. If the check fails, the function shall raise the development error V2XM\_E\_PARAM\_POINTER otherwise (if DET is disabled) return V2X\_E\_NOT\_OK. ] ( )

**[SWS\_V2xM\_00187]** [

If development error detection is enabled: the function shall check the parameter Ssp for being valid. If the check fails, the function shall raise the development error V2XM\_E\_PARAM\_POINTER otherwise (if DET is disabled) return V2X\_E\_NOT\_OK. ] ( )

### 8.3.7 V2xM\_TriggerPseudonymChange

[SWS\_V2xM\_00077]

<b>Service Name</b>	V2xM_TriggerPseudonymChange	
<b>Syntax</b>	Std_ReturnType V2xM_TriggerPseudonymChange ( void )	
<b>Service ID [hex]</b>	0x08	
<b>Sync/Async</b>	Synchronous	
<b>Reentrancy</b>	Non Reentrant	
<b>Parameters (in)</b>	None	
<b>Parameters (inout)</b>	None	
<b>Parameters (out)</b>	None	
<b>Return value</b>	Std_ReturnType	E_OK: request successful E_NOT_OK: request failed
<b>Description</b>	This function is called by the V2xFac, V2xGn or another entity to change the Pseudonym used by the V2X-Stack, e.g. due to a GeoNetworking address conflict.	
<b>Available via</b>	V2xM.h	

]()

[SWS\_V2xM\_00142]

The function V2xM\_TriggerPseudonymChange shall trigger the pseudonym change and update the identity of the V2X-Stack to the adjacent modules. ] ( )

[SWS\_V2xM\_00143]

If development error detection is enabled: the function shall check that the service V2xM\_Init was previously called. If the check fails, the function shall raise the development error V2XM\_E\_UNINIT. ] ( )

[SWS\_V2xM\_00144] If the pseudonym change is locked E\_NOT\_OK shall be returned ]()

### 8.3.8 V2xM\_LockPseudonymChange

[SWS\_V2xM\_00078]

<b>Service Name</b>	V2xM_LockPseudonymChange	
<b>Syntax</b>	Std_ReturnType V2xM_LockPseudonymChange (	

	<pre>uint16 Duration, uint64* HandleId )</pre>	
<b>Service ID [hex]</b>	0x09	
<b>Sync/Async</b>	Synchronous	
<b>Reentrancy</b>	Reentrant	
<b>Parameters (in)</b>	Duration	Number of seconds to lock
<b>Parameters (inout)</b>	None	
<b>Parameters (out)</b>	HandleId	Handle to unlock manually
<b>Return value</b>	Std_ReturnType	E_OK: request successful E_NOT_OK: request failed
<b>Description</b>	This function is called by V2xGn or from the Application Service Interface to lock the pseudonym change.	
<b>Available via</b>	V2xM.h	

l()

#### [SWS\_V2xM\_00145] [

The function V2xM\_LockPseudonymChange shall prevent the module from changing the pseudonym. The requirements from [22] shall apply.] ( )

#### [SWS\_V2xM\_00146] [

If development error detection is enabled: the function shall check that the service V2xM\_Init was previously called. If the check fails, the function shall raise the development error V2XM\_E\_UNINIT. ] ( )

#### [SWS\_V2xM\_00147] [

If development error detection is enabled: the function shall check the parameter HandleId for being valid. If the check fails, the function shall raise the development error V2XM\_E\_PARAM\_POINTER. ] ( )

### 8.3.9 V2xM\_UnlockPseudonymChange

#### [SWS\_V2xM\_00079] [

<b>Service Name</b>	V2xM_UnlockPseudonymChange	
<b>Syntax</b>	<pre>Std_ReturnType V2xM_UnlockPseudonymChange (     uint64 HandleId )</pre>	
<b>Service ID [hex]</b>	0x0a	
<b>Sync/Async</b>	Synchronous	

<b>Reentrancy</b>	Reentrant	
<b>Parameters (in)</b>	HandleId	Handle to unlock manually, available from LockPseudonym Change function.
<b>Parameters (inout)</b>	None	
<b>Parameters (out)</b>	None	
<b>Return value</b>	Std_Return-Type	E_OK: request successful E_NOT_OK: request failed
<b>Description</b>	This function is called by V2xGn or from the Application Service Interface to unlock the pseudonym change.	
<b>Available via</b>	V2xM.h	

]()

**[SWS\_V2xM\_00149]** [

The function V2xM\_UnlockPseudonymChange shall allow the module to change the pseudonym again.] ( )

**[SWS\_V2xM\_00150]** [

If development error detection is enabled: the function shall check that the service V2xM\_Init was previously called. If the check fails, the function shall raise the development error V2XM\_E\_UNINIT.] ( )

**[SWS\_V2xM\_00151]** [

If development error detection is enabled: the function shall check the parameter HandleId for being valid. If the check fails, the function shall raise the development error V2XM\_E\_PARAM.] ( )

### 8.3.10 V2xM\_V2xGn\_SetGlobalRxParams

**[SWS\_V2xM\_00080]**[

<b>Service Name</b>	V2xM_V2xGn_SetGlobalRxParams	
<b>Syntax</b>	<pre>void V2xM_V2xGn_SetGlobalRxParams (     const uint16* Cbr_Gs,     const V2x_ChannelType* Channel )</pre>	
<b>Service ID [hex]</b>	0x0b	
<b>Sync/Async</b>	Synchronous	
<b>Reentrancy</b>	Non Reentrant	
<b>Parameters (in)</b>	Cbr_Gs	List of current channel busy values
	Channel	List of channel types to that the busy values belong to

<b>Parameters (inout)</b>	None
<b>Parameters (out)</b>	None
<b>Return value</b>	None
<b>Description</b>	This function is called by V2xGn to set the current channel busy percentage for the specified channel
<b>Available via</b>	V2xM_V2xGn.h

]()

#### [SWS\_V2xM\_00154] [

If development error detection is enabled: the function shall check that the service V2xM\_Init was previously called. If the check fails, the function shall raise the development error V2XM\_E\_UNINIT. ]()

#### [SWS\_V2xM\_00155] [

If development error detection is enabled: the function shall check the parameter Cbr\_G for being valid. If the check fails, the function shall raise the development error V2XM\_E\_PARAM\_POINTER. ]()

#### [SWS\_V2xM\_00156] [

If development error detection is enabled: the function shall check the parameter Channel for being valid. If the check fails, the function shall raise the development error V2XM\_E\_PARAM\_POINTER. ]()

### 8.3.11 V2xM\_V2xGn\_GetGlobalTxParams

#### [SWS\_V2xM\_00081][

<b>Service Name</b>	V2xM_V2xGn_GetGlobalTxParams	
<b>Syntax</b>	<pre>void V2xM_V2xGn_GetGlobalTxParams (     const V2x_ChanType* channel,     uint16* Cbr )</pre>	
<b>Service ID [hex]</b>	0x0c	
<b>Sync/Async</b>	Synchronous	
<b>Reentrancy</b>	Non Reentrant	
<b>Parameters (in)</b>	channel	List of channels
<b>Parameters (inout)</b>	None	
<b>Parameters (out)</b>	Cbr	List of current channel busy values (in tenths of a percent) for the specified channel type
<b>Return value</b>	None	



<b>Description</b>	This function is called by V2xGn to get the current channel busy percentage for the specified channel
<b>Available via</b>	V2xM_V2xGn.h

]()

**[SWS\_V2xM\_00158]** [

The function V2xM\_V2xGn\_GetGlobalTxParams shall change provide a list with CBR values for the specific list of channels. ] ( )

**[SWS\_V2xM\_00159]** [

If development error detection is enabled: the function shall check that the service V2xM\_Init was previously called. If the check fails, the function shall raise the development error V2XM\_E\_UNINIT. ] ( )

**[SWS\_V2xM\_00160]** [

If development error detection is enabled: the function shall check the parameter Cbr for being valid. If the check fails, the function shall raise the development error V2XM\_E\_PARAM\_POINTER. ] ( )

**[SWS\_V2xM\_00161]** [

If development error detection is enabled: the function shall check the parameter Channel for being valid. If the check fails, the function shall raise the development error V2XM\_E\_PARAM\_POINTER. ] ( )

### 8.3.12 V2xM\_CalcDistance

**[SWS\_V2xM\_00176]**[

<b>Service Name</b>	V2xM_CalcDistance	
<b>Syntax</b>	<pre>Std_ReturnType V2xM_CalcDistance (     sint32 LatitudeA,     sint32 LongitudeA,     sint32 LatitudeB,     sint32 LongitudeB,     float32* Distance )</pre>	
<b>Service ID [hex]</b>	0x0e	
<b>Sync/Async</b>	Synchronous	
<b>Reentrancy</b>	Reentrant	
<b>Parameters (in)</b>	LatitudeA	Latitude of geographical point A
	LongitudeA	Longitude of geographical point A
	LatitudeB	Latitude of geographical point B
	LongitudeB	Longitude of geographical point B
<b>Parameters</b>	None	

<b>(inout)</b>		
<b>Parameters (out)</b>	Distance	Distance between geographical points A and B [m]
<b>Return value</b>	Std_ReturnType	E_OK: Calculation ok E_NOT_OK: Calculation failed, input parameters out of range
<b>Description</b>	Calculates the distance between two geographical points on earth with the assumption that they are on elevation 0.	
<b>Available via</b>	V2xM.h	

](SRS\_V2X\_00280)

### [SWS\_V2xM\_00181]

If development error detection is enabled: the function shall check the parameter Distance for being valid. If the check fails, the function shall raise the development error V2XM\_E\_PARAM\_POINTER. ] ( )

### 8.3.13 V2xM\_CalcHeadingInTolerance

#### [SWS\_V2xM\_00178]

<b>Service Name</b>	V2xM_CalcHeadingInTolerance	
<b>Syntax</b>	<pre>boolean V2xM_CalcHeadingInTolerance (     float32 Heading1,     float32 Heading2,     float32 Tolerance )</pre>	
<b>Service ID [hex]</b>	0x0f	
<b>Sync/Async</b>	Synchronous	
<b>Reentrancy</b>	Reentrant	
<b>Parameters (in)</b>	Heading1	First heading value
	Heading2	Second heading value
	Tolerance	Allowed tolerance between heading values
<b>Parameters (inout)</b>	None	
<b>Parameters (out)</b>	None	
<b>Return value</b>	boolean	TRUE: diff of headings is within tolerance FALSE: diff of headings is outside tolerance
<b>Description</b>	Calculates if difference of heading values are within a tolerance value	
<b>Available via</b>	V2xM.h	

]()

### 8.3.14 V2xM\_SetTollingZoneInformation

#### [SWS\_V2xM\_00182]

<b>Service Name</b>	V2xM_SetTollingZoneInformation	
<b>Syntax</b>	<pre>void V2xM_SetTollingZoneInformation (     sint32 protectedZoneLatitude,     sint32 protectedZoneLongitude,     uint32 protectedZoneRadius,     uint8 protectedZoneID )</pre>	
<b>Service ID [hex]</b>	0x10	
<b>Sync/Async</b>	Synchronous	
<b>Reentrancy</b>	Reentrant	
<b>Parameters (in)</b>	protectedZone Latitude	Latitude of the tolling zone
	protectedZone Longitude	Longitude of the tolling zone
	protectedZone Radius	radius of the protected zone in meter, use default value of 55m if not known
	protectedZoneID	ID of the tolling zone, use 0xFFFFFFFF if not known
<b>Parameters (inout)</b>	None	
<b>Parameters (out)</b>	None	
<b>Return value</b>	None	
<b>Description</b>	Set available tolling zone information. This is done from V2xFac that receives this information via CAM messages.	
<b>Available via</b>	V2xM.h	

]()

#### [SWS\_V2xM\_00190] [

The V2xM Module shall check the provided positional information. In case of a distance less than given in protectedZoneRadius, tolling zone power reduction shall be enabled. ]()

#### [SWS\_V2xM\_00170] [

Used for handling of tolling zone power reduction.

If the distance to a Tolling Zone position given by V2xM\_SetTollingZoneInformation is less than the distance given in protectedZoneRadius, the module shall push that to the WEthTrcv via the API EthIf\_SetRadioParams so that WEthTrcv is able to reduce output power of specific packets. If the position drops out of the range, tolling zone power reduction shall be switched off. ]()

**[SWS\_V2XM\_20460] [**

The V2X Management module shall implement a protected zone center position list. The minimum is to build in the official list provided by the ASECAP (not supposed to be updated except by a firmware update).

Protected Zones with identical protectedZone ID may be seen as a single station. In case the ASECAP database and the CEN-DSRC mitigation CAMs contains a valid protection zone with the identical protectedZone ID mitigation shall be done only based on the CEN-DSRC mitigation CAM content. ]()

## 8.4 Call-back notifications

### 8.4.1 CSM callback interfaces

**[SWS\_V2xM\_00163] [**

If the V2xM module uses the Csm module asynchronously to calculate or verify the signatures, V2xM shall provide callback functions according to Csm\_CallbackType. ] (SRS\_BSW\_00457)

## 8.5 Scheduled functions

### 8.5.1 V2xM\_MainFunction

**[SWS\_V2xM\_00164][**

<b>Service Name</b>	V2xM_MainFunction
<b>Syntax</b>	void V2xM_MainFunction ( void )
<b>Service ID [hex]</b>	0x0D
<b>Description</b>	Scheduled MainFunction of V2xM
<b>Available via</b>	SchM_V2xM.h

]()

**[SWS\_V2xM\_00165] [**

Used for polling DCC information via EthIf\_GetChanRxParamsAPI call from Wireless Ethernet Transceiver Driver. ] ( )

**[SWS\_V2xM\_00166]** [ Used for cyclic pseudonym change. ] ( )

**[SWS\_V2xM\_00167]** [ Used for pushing DCC information to adjacent V2X modules. ] ( )

**[SWS\_V2xM\_00168]** [ Used for polling state of asynchronous security functions of CSM. ] ( )

**[SWS\_V2xM\_00169]** [ Used for automatic unlocking of pseudonym changes if locking interval is due. ] ( )

## 8.6 Expected Interfaces

In this chapter all external interfaces required from other modules are listed.

### 8.6.1 Mandatory Interfaces

This chapter defines all external interfaces which are required to fulfill the core functionality of the module.

**[SWS\_V2xM\_00092]**

<b>API Function</b>	<b>Header File</b>	<b>Description</b>
Csm_Hash	Csm.h	Uses the given data to perform the hash calculation and stores the hash.
Csm_KeyElementGet	Csm.h	Retrieves the key element bytes from a specific key element of the key identified by the keyId and stores the key element in the memory location pointed by the key pointer.
Csm_KeyElementSet	Csm.h	Sets the given key element bytes to the key identified by keyId.
Csm_Random-Generate	Csm.h	Generate a random number and stores it in the memory location pointed by the result pointer.
Csm_Signature-Generate	Csm.h	Uses the given data to perform the signature calculation and stores the signature in the memory location pointed by the result pointer.
Csm_SignatureVerify	Csm.h	Verifies the given MAC by comparing if the signature is generated with the given data.
Ethlf_GetChanRx-Params	Ethlf.h	Read values related to the receive direction of the transceiver. For example, this could be a Channel Busy Ratio (CBR) or the average Channel Idle Time (CIT).
Ethlf_SetChanRx-Params	Ethlf.h	Set values related to the receive direction of a transceiver's wireless channel. For example, this could be a channel parameter like the frequency.

Ethlf_SetChanTx-Params	Ethlf.h	Set values related to the transmit direction of a transceiver's wireless channel. For example, this could be the bitrate of a channel.
Ethlf_SetPhysAddr	Ethlf.h	Sets the physical source address used by the indexed controller.
Ethlf_SetRadio-Params	Ethlf.h	Set values related to a transceiver's wireless radio. For example, this could be the selection of the radio settings (channel, ...).
NvM_GetErrorStatus	NvM.h	Service to read the block dependent error/status information.
NvM_ReadBlock	NvM.h	Service to copy the data of the NV block to its corresponding RAM block.
NvM_WriteBlock	NvM.h	Service to copy the data of the RAM block to its corresponding NV block.
V2xFac_V2xM_Abort-PseudonymChange	V2xFac_V2xM.h	This function is called by the V2xM when not all modules are OK with the pseudonym change and the change is to be rolled back.
V2xFac_V2xM_-CommitPseudonym-Change	V2xFac_V2xM.h	This function is called by the V2xM when all modules are OK with the pseudonym change and the change is to be committed.
V2xFac_V2xM_-PreparePseudonym-Change	V2xFac_V2xM.h	By this API primitive the V2xFac module gets an indication that the given Pseudonym and hereby the StationId is about to be changed
V2xFac_V2xM_Set-CaBsOperation	V2xFac_V2xM.h	By this API primitive the V2xFac module gets an indication of the current operation state of the CA Basic Service.
V2xFac_V2xM_SetT-GenCamDcc	V2xFac_V2xM.h	By this API primitive the V2xFac module gets an indication of the current TGenCamDcc value.
V2xGn_V2xM_Abort-PseudonymChange	V2xGn_V2xM.h	This function is called by the V2xM when not all modules are OK with the pseudonym change and the change is to be rolled back.
V2xGn_V2xM_-CommitPseudonym-Change	V2xGn_V2xM.h	This function is called by the V2xM when all modules are OK with the pseudonym change and the change is to be committed.
V2xGn_V2xM_Decap-Confirmation	V2xGn_V2xM.h	This function is called by the V2xM when a decapsulation has been finished.
V2xGn_V2xM_Encap-Confirmation	V2xGn_V2xM.h	This function is called by the V2xM when an encapsulation has been finished.
V2xGn_V2xM_-PreparePseudonym-Change	V2xGn_V2xM.h	This function is called by the V2xM when a Pseudonym Change occurs to prepare the change in every module using it.

l()

## 8.6.2 Optional Interfaces

This chapter defines all external interfaces which are required to fulfill an optional functionality of the module.

### [SWS\_V2xM\_00093]

<b>API Function</b>	<b>Header File</b>	<b>Description</b>
Det_ReportError	Det.h	Service to report development errors.
Efx_ArcCos_s32_u32	Efx.h	This service computes the inverse cosine of a value.
Efx_ArcSin_s32_s32	Efx.h	This service computes the inverse sine of a value.
Efx_Cos_s32_s32	Efx.h	This service computes the cosine of an angle.
Efx_Sin_s32_s32	Efx.h	This service computes the sine of an angle.
Efx_Sqrt_u32_u32	Efx.h	This service computes the square root of a value
Gpt_GetPredef-TimerValue	Gpt.h	Delivers the current value of the desired GPT Predef Timer.
Gpt_StartTimer	Gpt.h	Starts a timer channel.
Mfl_ArcCos_f32	Mfl.h	Returns the arc cosine of an angle, in the range of 0.0 through pi.
Mfl_ArcSin_f32	Mfl.h	Returns the arc sine of an angle, in the range of -pi/2 through pi/2.
Mfl_Cos_f32	Mfl.h	Calculates the cosine of the argument.
Mfl_Sin_f32	Mfl.h	Calculates the sine of the argument.
Mfl_Sqrt_f32	Mfl.h	Returns the square root of the operand (ValSqrt), determined according to the following equation
StbM_Get-CurrentTime	StbM.h	Returns a time value (Local Time Base derived from Global Time Base) in standard format. Note: This API shall be called with locked interrupts / within an Exclusive Area to prevent interruption (i.e., the risk that the time stamp is outdated on return of the function call).
StbM_Get-CurrentTime-Extended	StbM.h	Returns a time value (Local Time Base derived from Global Time Base) in extended format. Note: This API shall be called with locked interrupts / within an Exclusive Area to prevent interruption (i.e., the risk that the time stamp is outdated on return of the function call).

l()

## 8.7 Service Interfaces

### 8.7.1 Client-Server-Interfaces

#### 8.7.1.1 V2xM\_Vdp

##### [SWS\_V2xM\_00095]

<b>Name</b>	V2xM_Vdp		
<b>Comment</b>	Interfaces for Vehicle Data Provider (VDP) to get and set V2X related vehicle information in the BSW V2X-Stack		
<b>IsService</b>	true		
<b>Variation</b>	--		
<b>Possible Errors</b>	0	E_OK	Operation successful
	1	E_NOT_OK	Operation failed

<b>Operation</b>	GetNextLongTermCertificateExpirationDate		
<b>Comment</b>	Service to get the certificate expiration date of the long term certificates that expires in the nearest future.		
<b>Variation</b>	--		
<b>Parameters</b>	ExpirationDate		
	<b>Type</b>	uint32	
	<b>Direction</b>	OUT	
	<b>Comment</b>	Date is based on format Time32 that is specified in IEEE 1609.2 as mentioned in [19].	
<b>Possible Errors</b>	E_OK E_NOT_OK		

<b>Operation</b>	GetNextPseudonymCertificateExpirationDate		
<b>Comment</b>	Service to get the certificate expiration date of the pseudonym certificates that expires in the nearest future.		
<b>Variation</b>	--		
<b>Parameters</b>	ExpirationDate		
	<b>Type</b>	uint32	
	<b>Direction</b>	OUT	
	<b>Comment</b>	Date is based on format Time32 that is specified in IEEE 1609.2 as	



		mentioned in [19]
	<b>Variation</b>	--
<b>Possible Errors</b>	E_OK E_NOT_OK	

<b>Operation</b>	GetTime32	
<b>Comment</b>	Service to get the current reference time.	
<b>Variation</b>	--	
<b>Parameters</b>	Time32	
	<b>Type</b>	uint32
	<b>Direction</b>	OUT
	<b>Comment</b>	Time is based on TAI mod $2^{32}$ , where TAI is the number of elapsed TAI milliseconds since 2004-01-01 00:00:00.000.
	<b>Variation</b>	--
<b>Possible Errors</b>	E_OK E_NOT_OK	

<b>Operation</b>	SetPositionAndTime	
<b>Comment</b>	Service for setting positional and time information relevant for the V2X-Stack	
<b>Variation</b>	--	
<b>Parameters</b>	positionAndTime	
	<b>Type</b>	V2xM_PositionAndTimeType
	<b>Direction</b>	IN
	<b>Comment</b>	--
	<b>Variation</b>	--
<b>Possible Errors</b>	E_OK E_NOT_OK	

](SRS\_V2X\_00412, SRS\_V2X\_00413, SRS\_V2X\_00190)

### 8.7.1.2 V2xM\_PseudonymChange

[SWS\_V2xM\_00172]

<b>Name</b>	V2xM_PseudonymChange
<b>Comment</b>	Interfaces for Applications to lock and unlock pseudonym changes within the V2X-BSW-Stack.

<b>IsService</b>	true		
<b>Variation</b>	--		
<b>Possible Errors</b>	0	E_OK	Operation successful
	1	E_NOT_OK	Operation failed

<b>Operation</b>	Lock		
<b>Comment</b>	Service for locking the pseudonym change. See SWS_V2xM_00078 for more information about locking the pseudonym change.		
<b>Variation</b>	--		
<b>Parameters</b>	Duration		
	<b>Type</b>	uint16	
	<b>Direction</b>	IN	
	<b>Comment</b>	Duration to lock.	
	<b>Variation</b>	--	
	HandleId		
	<b>Type</b>	uint64	
	<b>Direction</b>	OUT	
	<b>Comment</b>	HandleId for manual Unlock	
	<b>Variation</b>	--	
<b>Possible Errors</b>	E_OK E_NOT_OK		

<b>Operation</b>	Unlock		
<b>Comment</b>	Service for unlocking the pseudonym change. See SWS_V2xM_00079 for more information about locking the pseudonym change.		
<b>Variation</b>	--		
<b>Parameters</b>	HandleId		
	<b>Type</b>	uint64	
	<b>Direction</b>	IN	
	<b>Comment</b>	HandleId to unlock	
	<b>Variation</b>	--	
<b>Possible Errors</b>	E_OK E_NOT_OK		

]()

### 8.7.1.3 V2xM\_Sec

[SWS\_V2xM\_00173]

<b>Name</b>	V2xM_Sec		
<b>Comment</b>	Security related interfaces for applications		
<b>IsService</b>	true		
<b>Variation</b>	--		
<b>Possible Errors</b>	0	E_OK	Operation successful
	1	E_NOT_OK	Operation failed

<b>Operation</b>	Verify		
<b>Comment</b>	Interfaces for Applications to verify messages on demand instead of verify all incoming messages, to reduce ECU load.		
<b>Variation</b>	--		
<b>Parameters</b>	TransactionId32		
	<b>Type</b>	uint32	
	<b>Direction</b>	IN	
	<b>Comment</b>	TransactionId of the packet to be verified	
	<b>Variation</b>	--	
	SecReport		
	<b>Type</b>	V2xM_SecReportType	
	<b>Direction</b>	OUT	
	<b>Comment</b>	--	
	<b>Variation</b>	--	
<b>Possible Errors</b>	E_OK E_NOT_OK		

]()

### 8.7.1.4 V2xM\_GeoMath

[SWS\_V2xM\_00180]

<b>Name</b>	V2xM_GeoMath
<b>Comment</b>	Interfaces for Applications to math functions

<b>IsService</b>	true		
<b>Variation</b>	--		
<b>Possible Errors</b>	0	E_OK	Operation successful
	1	E_NOT_OK	Operation failed

<b>Operation</b>	Distance		
<b>Comment</b>	Service for Calculating the distance between two geographical points		
<b>Variation</b>	--		
<b>Parameters</b>	latitudeA		
	<b>Type</b>	sint32	
	<b>Direction</b>	IN	
	<b>Comment</b>	Latitude of geographical point A	
	<b>Variation</b>	--	
	longitudeA		
	<b>Type</b>	sint32	
	<b>Direction</b>	IN	
	<b>Comment</b>	Longitude of geographical point A	
	<b>Variation</b>	--	
	latitudeB		
	<b>Type</b>	sint32	
	<b>Direction</b>	IN	
	<b>Comment</b>	Latitude of geographical point B	
	<b>Variation</b>	--	
	longitudeB		
	<b>Type</b>	sint32	
	<b>Direction</b>	IN	
	<b>Comment</b>	Longitude of geographical point B	
	<b>Variation</b>	--	
distance			
<b>Type</b>	float32		
<b>Direction</b>	OUT		

	<b>Comment</b>	Distance between geographical points A and B in [m].
	<b>Variation</b>	--
<b>Possible Errors</b>	E_OK E_NOT_OK	

<b>Operation</b>	HeadingInTolerance	
<b>Comment</b>	Service for Calculating if difference of heading values are within a tolerance value	
<b>Variation</b>	--	
<b>Parameters</b>	heading1	
	<b>Type</b>	float32
	<b>Direction</b>	IN
	<b>Comment</b>	First heading value
	<b>Variation</b>	--
	heading2	
	<b>Type</b>	float32
	<b>Direction</b>	IN
	<b>Comment</b>	Next heading value
	<b>Variation</b>	--
	toleranceValue	
	<b>Type</b>	float32
	<b>Direction</b>	IN
	<b>Comment</b>	Tolerated difference between heading1 and heading2
	<b>Variation</b>	--
	tolerated	
<b>Type</b>	boolean	
<b>Direction</b>	OUT	
<b>Comment</b>	Return value	
<b>Variation</b>	--	
<b>Possible Errors</b>	E_OK E_NOT_OK	

]()

## 8.7.2 Implementation Data Types

### 8.7.2.1 ImplementationDataType V2xM\_SecReportType

[SWS\_V2xM\_91000]

<b>Name</b>	V2xM_SecReportType		
<b>Kind</b>	Type		
<b>Derived from</b>	uint8		
<b>Range</b>	V2X_SECREP_SUCCESS	0x00	Indicating security service has successfully executed
	V2X_SECREP_FALSE_SIGNATURE	0x01	Indicating false signature
	V2X_SECREP_INVALID_CERTIFICATE	0x02	Indicating invalid certificate
	V2X_SECREP_REVOKED_CERTIFICATE	0x03	Indicating revoked certificate
	V2X_SECREP_INCONSISTENT_CHAIN	0x04	Indicating inconsistent certificate chain
	V2X_SECREP_INVALID_TIMESTAMP	0x05	Indicating invalid timestamp
	V2X_SECREP_DUPLICATE_MESSAGE	0x06	Indicating duplicate message
	V2X_SECREP_INVALID_MOBILITY_DATA	0x07	Indicating invalid mobility data
	V2X_SECREP_UNSIGNED_MESSAGE	0x08	Indicating unsigned message
	V2X_SECREP_SIGNER_CERTIFICATE_NOT_FOUND	0x09	Indicating signer certificate not found
	V2X_SECREP_UNSUPPORTED_SIGNER_IDENTIFIER_TYPE	0x0a	Indicating unsupported signer identifier type
	V2X_SECREP_INCOMPATIBLE_PROTOCOL	0x0b	Indicating incompatible protocol
	V2X_SECREP_UNENCRYPTED_MESSAGE	0x0c	Indicating unencrypted message
	V2X_SECREP_DECRYPTION_ERROR	0x0d	Indicating decryption error
V2X_SECREP_NONE	0xff	Indicating no security service has been executed.	
<b>Description</b>	Used to describe the security report after invocation of security services for Decapsulation (verify or decrypt)		
<b>Variation</b>	--		
<b>Available via</b>	Rte_V2xM_Type.h		

]()

### 8.7.2.2 ImplementationDataType V2xM\_PositionAndTimeType

**[SWS\_V2xM\_00047]**

<b>Name</b>	V2xM_PositionAndTimeType	
<b>Kind</b>	Structure	
<b>Elements</b>	latitude	
	<b>Type</b>	sint32
	<b>Comment</b>	Latitude [1/10 microdegree]
	longitude	
	<b>Type</b>	sint32
	<b>Comment</b>	Longitude [1/10 microdegree]
	altitude	
	<b>Type</b>	sint32
	<b>Comment</b>	Altitude [1/100 m]
	speed	
	<b>Type</b>	sint16
	<b>Comment</b>	Speed [1/100 m/s]
	heading	
	<b>Type</b>	uint16
	<b>Comment</b>	Heading [1/10 degrees]
	timestamp	
	<b>Type</b>	uint32
	<b>Comment</b>	Timestamp [ms]
	semiMajorConfidence	
	<b>Type</b>	uint16
	<b>Comment</b>	From position confidence ellipse
	semiMinorConfidence	
	<b>Type</b>	uint16
	<b>Comment</b>	From position confidence ellipse
semiMajorOrientation		

	<b>Type</b>	uint16
	<b>Comment</b>	From position confidence ellipse
	pai	
	<b>Type</b>	boolean
	<b>Comment</b>	Positional accuracy indicator
	informationValid	
	<b>Type</b>	boolean
	<b>Comment</b>	Indicates that position information is valid
<b>Description</b>	Position and time related information as defined within [25] chapter 8.2.	
<b>Variation</b>	--	
<b>Available via</b>	Rte_V2xM_Type.h	

]()

### 8.7.3 Ports

#### 8.7.3.1 V2xM\_V2xM\_GeoMath

[SWS\_V2xM\_00192]

<b>Name</b>	V2xM_GeoMath		
<b>Kind</b>	ProvidedPort	<b>Interface</b>	V2xM_GeoMath
<b>Description</b>	Service port for geographical calculation requests.		
<b>Variation</b>	--		

]()

#### 8.7.3.2 V2xM\_V2xM\_PseudonymChange

[SWS\_V2xM\_00193]

<b>Name</b>	V2xM_PseudonymChange		
<b>Kind</b>	ProvidedPort	<b>Interface</b>	V2xM_PseudonymChange
<b>Description</b>	Service port for pseudonym lock and unlock requests.		
<b>Variation</b>	--		

]()

#### 8.7.3.3 V2xM\_V2xM\_Sec

[SWS\_V2xM\_00194]



<b>Name</b>	V2xM_Sec		
<b>Kind</b>	ProvidedPort	<b>Interface</b>	V2xM_Sec
<b>Description</b>	Service port for security operations of V2X messages.		
<b>Variation</b>	--		

]()

#### 8.7.3.4 V2xM\_V2xM\_Vdp

[SWS\_V2xM\_00195]

<b>Name</b>	V2xM_Vdp		
<b>Kind</b>	ProvidedPort	<b>Interface</b>	V2xM_Vdp
<b>Description</b>	Service port for exchange of vehicle related data. This port is used by the Vehicle Data Provider SW-C.		
<b>Variation</b>	--		

]()

## 9 Sequence diagrams

### 9.1 V2xM\_Init – Time initialization

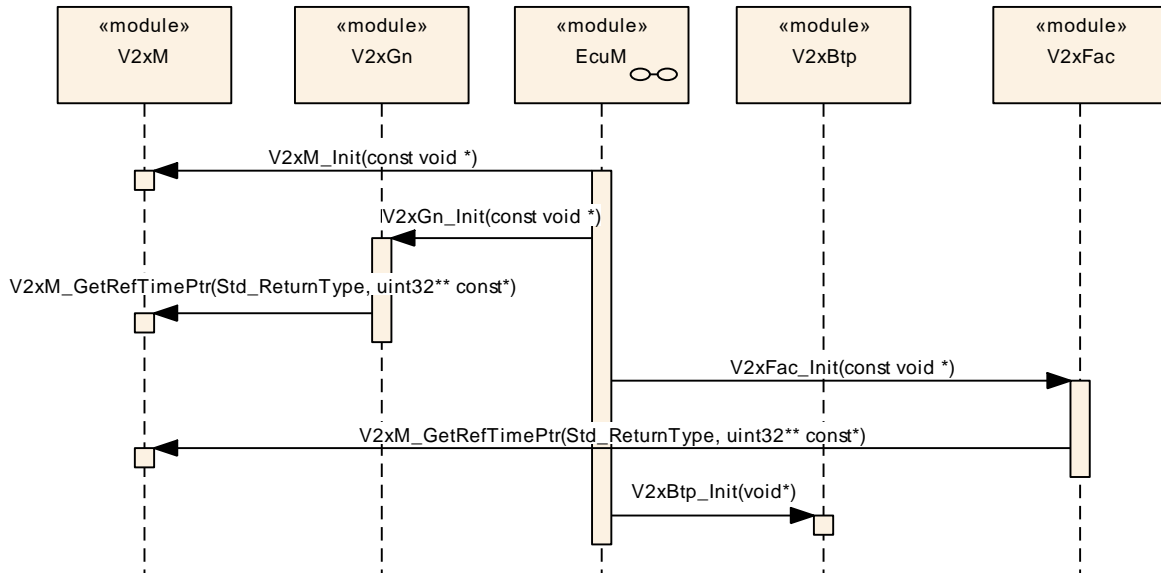
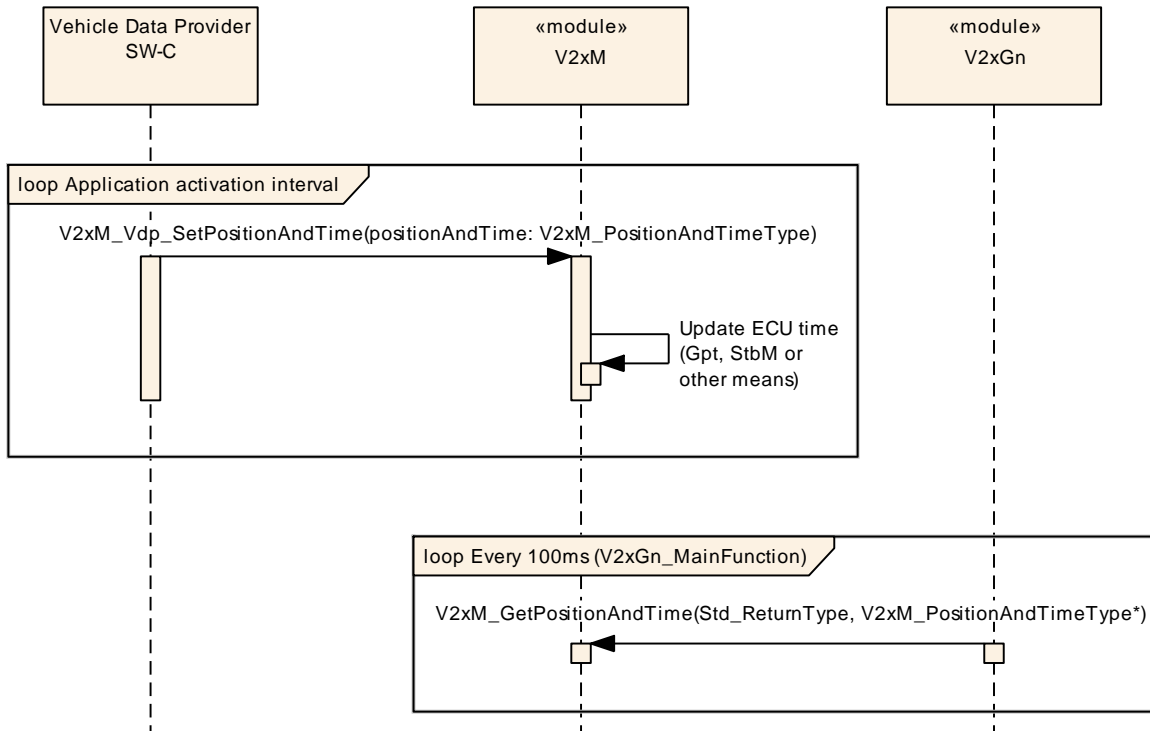

Figure 9-1: V2xM\_Init - Time initialization

## 9.2 Position and time update V2xGn



**Figure 9-2: Position and time update V2xGn**

### 9.3 Position and time update V2xFac

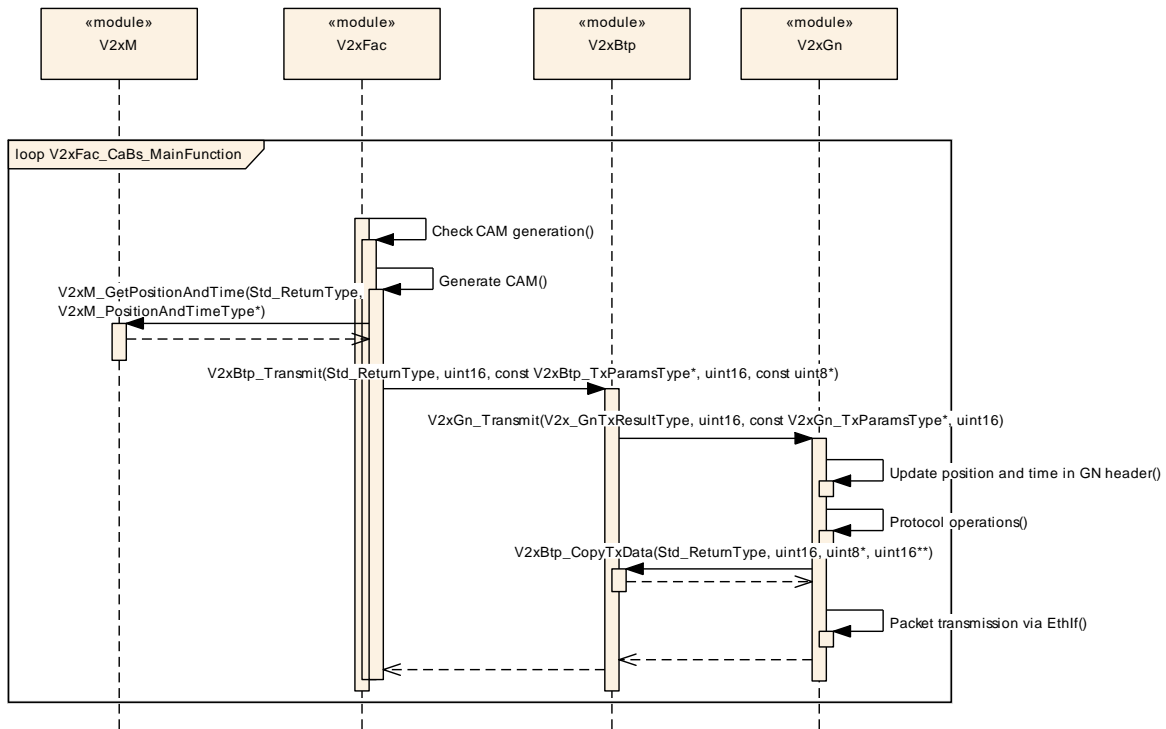

Figure 9-3: Position and time update V2xFac

### 9.4 Time handling at reception

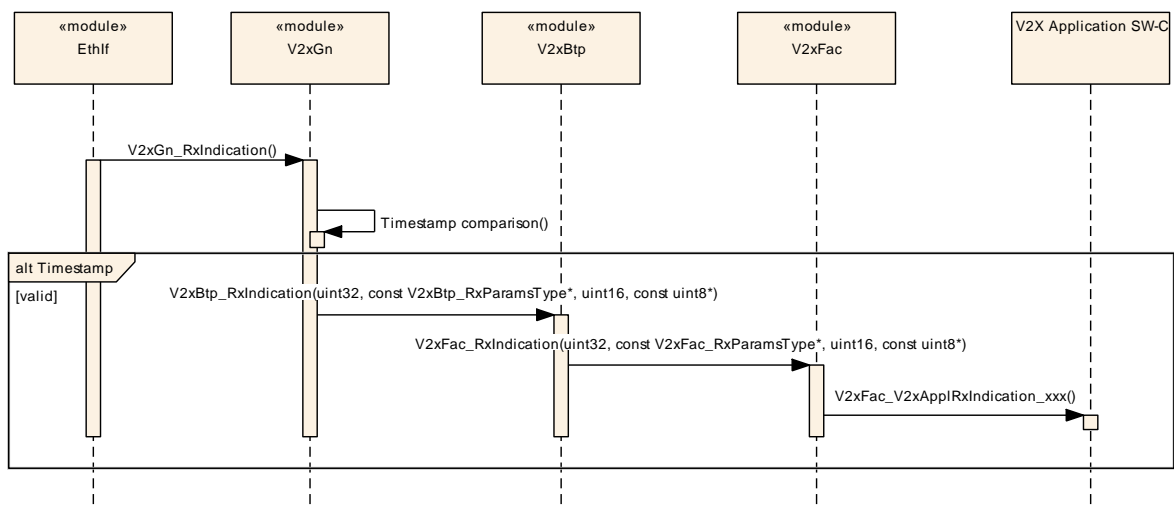

Figure 9-4 – Time handling at reception

### 9.5 Initialization of Wireless Drivers

The Initialization of the Wireless Ethernet Driver and the Wireless Ethernet Transceiver Driver shall be done as depicted in Figure 9-5.

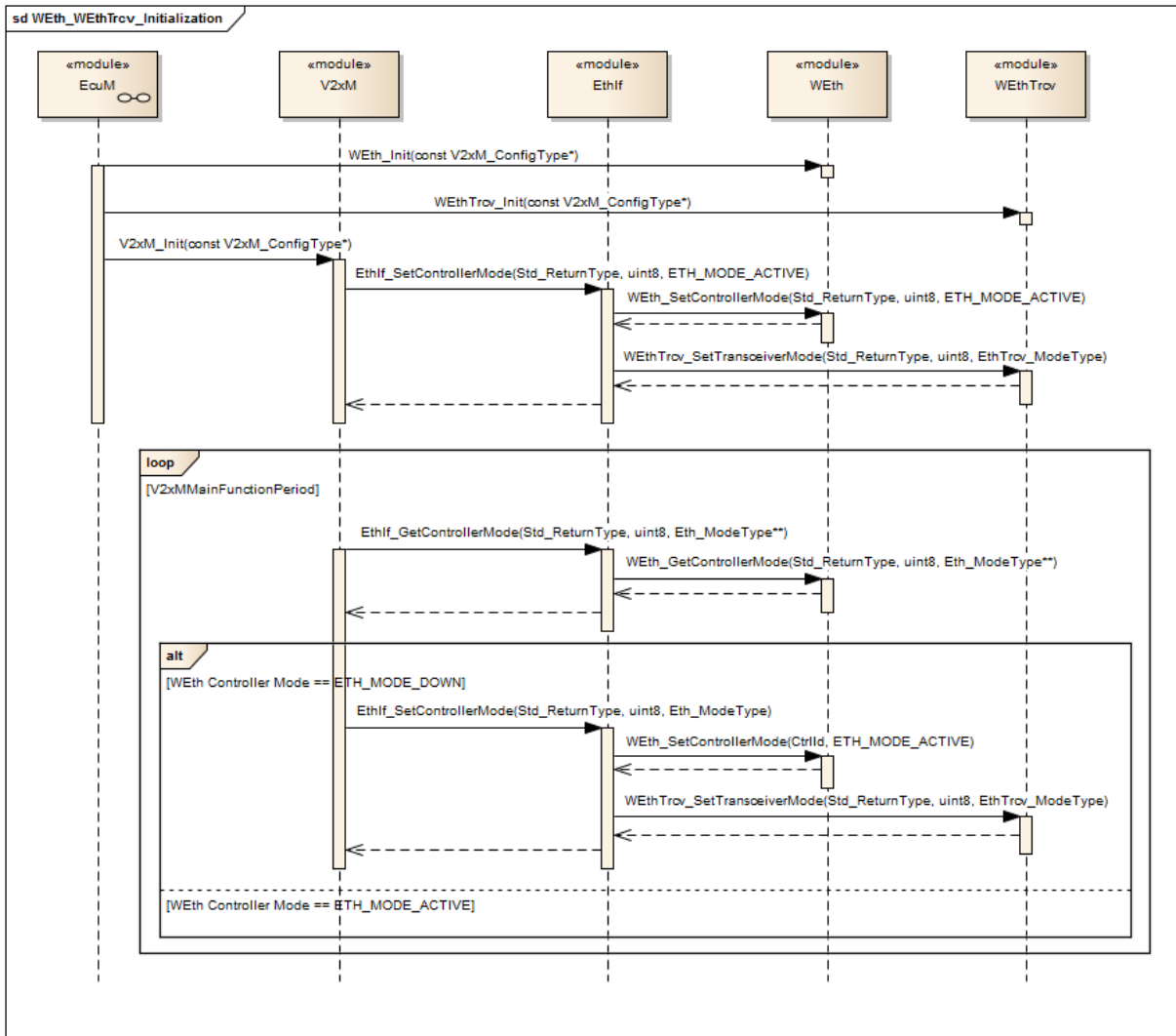

Figure 9-5: WEth and WEthTrcv initialization

## 10 Configuration specification

Chapter 10.1 specifies the structure (containers) and the parameters of the module V2xM.

Chapter 10.2 specifies additionally published information of the module V2xM.

### 10.1 Containers and configuration parameters

The following chapters summarize all configuration parameters. The detailed meanings of the parameters describe Chapters 7 and Chapter 8.

#### 10.1.1 Variants

**[SWS\_V2xM\_00191]** | The V2xM module only supports VARIANT-PRE-COMPILE |  
 (SRS\_BSW\_00345)

#### 10.1.2 V2xM

<b>SWS Item</b>	
<b>Module Name</b>	V2xM
<b>Module Description</b>	Configuration of the V2xM (V2XManagement) module.
<b>Post-Build Variant Support</b>	false
<b>Supported Config Variants</b>	VARIANT-PRE-COMPILE

<b>Included Containers</b>		
<b>Container Name</b>	<b>Multiplicity</b>	<b>Scope / Dependency</b>
V2xMConfig	1	This container contains the configuration parameters and sub containers of the AUTOSAR V2xM module.
V2xMGeneral	1	General configuration of V2xM module.

#### 10.1.3 V2xMConfig

<b>SWS Item</b>	<b>ECUC_V2xM_00001 :</b>
<b>Container Name</b>	V2xMConfig
<b>Parent Container</b>	V2xM
<b>Description</b>	This container contains the configuration parameters and sub containers of the AUTOSAR V2xM module.
<b>Configuration Parameters</b>	

<b>Included Containers</b>		
<b>Container Name</b>	<b>Multiplicity</b>	<b>Scope / Dependency</b>
V2xMSecurityConfig	1	Configuration of the security services of V2xM.

### 10.1.4 V2xMSecurityConfig

<b>SWS Item</b>	<b>ECUC_V2xM_00002 :</b>
<b>Container Name</b>	V2xMSecurityConfig
<b>Parent Container</b>	V2xMConfig
<b>Description</b>	Configuration of the security services of V2xM.
<b>Configuration Parameters</b>	

<b>SWS Item</b>	<b>ECUC_V2xM_00005 :</b>		
<b>Name</b>	V2xMSecurityVerificationOnDemand		
<b>Parent Container</b>	V2xMSecurityConfig		
<b>Description</b>	Switches the Verification on Demand (VoD) ON or OFF. <ul style="list-style-type: none"> <li>• true: enabled (ON)</li> <li>• false: disabled (OFF)</li> </ul>		
<b>Multiplicity</b>	1		
<b>Type</b>	EcucBooleanParamDef		
<b>Default value</b>	--		
<b>Post-Build Variant Value</b>	false		
<b>Value Configuration Class</b>	<b>Pre-compile time</b>	X	All Variants
	<b>Link time</b>	--	
	<b>Post-build time</b>	--	
<b>Scope / Dependency</b>	scope: local		

<b>SWS Item</b>	<b>ECUC_V2xM_00004 :</b>		
<b>Name</b>	V2xMSecurityNvMBlockDescriptorLongTermCertificates		
<b>Parent Container</b>	V2xMSecurityConfig		
<b>Description</b>	Reference to NVRAM block containing the none volatile data of long term certificates.		
<b>Multiplicity</b>	1		
<b>Type</b>	Symbolic name reference to [ NvMBlockDescriptor ]		
<b>Post-Build Variant Value</b>	false		
<b>Value Configuration Class</b>	<b>Pre-compile time</b>	X	All Variants
	<b>Link time</b>	--	
	<b>Post-build time</b>	--	
<b>Scope / Dependency</b>	scope: local		

<b>SWS Item</b>	<b>ECUC_V2xM_00003 :</b>		
<b>Name</b>	V2xMSecurityNvMBlockDescriptorPseudonymCertificates		
<b>Parent Container</b>	V2xMSecurityConfig		
<b>Description</b>	Reference to NVRAM block containing the none volatile data of pseudonym certificates.		
<b>Multiplicity</b>	1		
<b>Type</b>	Symbolic name reference to [ NvMBlockDescriptor ]		
<b>Post-Build Variant Value</b>	false		
<b>Value Configuration Class</b>	<b>Pre-compile time</b>	X	All Variants
	<b>Link time</b>	--	
	<b>Post-build time</b>	--	
<b>Scope / Dependency</b>	scope: local		

<b>SWS Item</b>	<b>ECUC_V2xM_00007 :</b>		
<b>Name</b>	V2xMSignatureGenerationConfigRef		
<b>Parent Container</b>	V2xMSecurityConfig		
<b>Description</b>	Select CSM service configuration that is used for authentication.		
<b>Multiplicity</b>	1		

<b>Type</b>	Reference to [ CsmSignatureGenerateConfig ]		
<b>Post-Build Variant Value</b>	false		
<b>Value Configuration Class</b>	<b>Pre-compile time</b>	X	All Variants
	<b>Link time</b>	--	
	<b>Post-build time</b>	--	
<b>Scope / Dependency</b>	scope: local		

<b>SWS Item</b>	<b>ECUC_V2xM_00006 :</b>		
<b>Name</b>	V2xMSignatureVerifyConfigRef		
<b>Parent Container</b>	V2xMSecurityConfig		
<b>Description</b>	Select CSM service configuration that is used for authentication.		
<b>Multiplicity</b>	1		
<b>Type</b>	Reference to [ CsmSignatureVerifyConfig ]		
<b>Post-Build Variant Value</b>	false		
<b>Value Configuration Class</b>	<b>Pre-compile time</b>	X	All Variants
	<b>Link time</b>	--	
	<b>Post-build time</b>	--	
<b>Scope / Dependency</b>	scope: local		

**No Included Containers**

### 10.1.5 V2xMGeneral

<b>SWS Item</b>	<b>ECUC_V2xM_00008 :</b>		
<b>Container Name</b>	V2xMGeneral		
<b>Parent Container</b>	V2xM		
<b>Description</b>	General configuration of V2xM module.		
<b>Configuration Parameters</b>			

<b>SWS Item</b>	<b>ECUC_V2xM_00009 :</b>		
<b>Name</b>	V2xMDevErrorDetect		
<b>Parent Container</b>	V2xMGeneral		
<b>Description</b>	Switches the Default Error Tracer (Det) detection and notification ON or OFF. <ul style="list-style-type: none"> <li>• true: enabled (ON)</li> <li>• false: disabled (OFF)</li> </ul>		
<b>Multiplicity</b>	1		
<b>Type</b>	EcucBooleanParamDef		
<b>Default value</b>	false		
<b>Post-Build Variant Value</b>	false		
<b>Value Configuration Class</b>	<b>Pre-compile time</b>	X	All Variants
	<b>Link time</b>	--	
	<b>Post-build time</b>	--	
<b>Scope / Dependency</b>	scope: local		

<b>SWS Item</b>	<b>ECUC_V2xM_00015 :</b>		
<b>Name</b>	V2xMMainFunctionPeriod		
<b>Parent Container</b>	V2xMGeneral		
<b>Description</b>	This parameter defines the schedule period of V2xM_MainFunction.Unit: [s]		
<b>Multiplicity</b>	1		
<b>Type</b>	EcucFloatParamDef		



<b>Range</b>	]0 .. 0.1[		
<b>Default value</b>	0.1		
<b>Post-Build Variant Value</b>	false		
<b>Value Configuration Class</b>	<b>Pre-compile time</b>	X	All Variants
	<b>Link time</b>	--	
	<b>Post-build time</b>	--	
<b>Scope / Dependency</b>	scope: local		

<b>SWS Item</b>	<b>ECUC_V2xM_00010 :</b>		
<b>Name</b>	V2xMVersionInfoApi		
<b>Parent Container</b>	V2xMGeneral		
<b>Description</b>	Enable/disables the API for reading the version information of the V2xM Module. <ul style="list-style-type: none"> <li>• true: enabled (ON)</li> <li>• false: disabled (OFF)</li> </ul>		
<b>Multiplicity</b>	1		
<b>Type</b>	EcucBooleanParamDef		
<b>Default value</b>	false		
<b>Post-Build Variant Value</b>	false		
<b>Value Configuration Class</b>	<b>Pre-compile time</b>	X	All Variants
	<b>Link time</b>	--	
	<b>Post-build time</b>	--	
<b>Scope / Dependency</b>	scope: local		

<b>SWS Item</b>	<b>ECUC_V2xM_00012 :</b>		
<b>Name</b>	V2xMEthIfCtrlRef		
<b>Parent Container</b>	V2xMGeneral		
<b>Description</b>	Reference to EthIf controller where the channel and radio parameters should be read and written to.		
<b>Multiplicity</b>	1		
<b>Type</b>	Symbolic name reference to [ EthIfController ]		
<b>Post-Build Variant Value</b>	false		
<b>Value Configuration Class</b>	<b>Pre-compile time</b>	X	All Variants
	<b>Link time</b>	--	
	<b>Post-build time</b>	--	
<b>Scope / Dependency</b>	scope: local		

<b>SWS Item</b>	<b>ECUC_V2xM_00013 :</b>		
<b>Name</b>	V2xMGptChannelConfigurationRef		
<b>Parent Container</b>	V2xMGeneral		
<b>Description</b>	Reference to General Purpose Timer.		
<b>Multiplicity</b>	0..1		
<b>Type</b>	Symbolic name reference to [ GptChannelConfiguration ]		
<b>Post-Build Variant Value</b>	false		
<b>Value Configuration Class</b>	<b>Pre-compile time</b>	X	All Variants
	<b>Link time</b>	--	
	<b>Post-build time</b>	--	
<b>Scope / Dependency</b>	scope: local		

<b>SWS Item</b>	<b>ECUC_V2xM_00011 :</b>		
<b>Name</b>	V2xMNvMBlockDescriptor		
<b>Parent Container</b>	V2xMGeneral		
<b>Description</b>	Reference to NVRAM block containing the none volatile data.		
<b>Multiplicity</b>	1		

<b>Type</b>	Symbolic name reference to [ NvMBlockDescriptor ]		
<b>Post-Build Variant Value</b>	false		
<b>Value Configuration Class</b>	<b>Pre-compile time</b>	X	All Variants
	<b>Link time</b>	--	
	<b>Post-build time</b>	--	
<b>Scope / Dependency</b>	scope: local		
<b>No Included Containers</b>			

## 11 Not applicable requirements