

Document Title	Specification of Timing Extension for Adaptive Platform
Document Owner	AUTOSAR
Document Responsibility	AUTOSAR
Document Identification No	968

Document Status	published
Part of AUTOSAR Standard	Adaptive Platform
Part of Standard Release	R21-11

Document Change History			
Date	Release	Changed by	Description
2021-11-25	R21-11	AUTOSAR Release Management	<ul style="list-style-type: none"> Corrected specification item numbers and constraint identifier numbers to make the number unique and indicated correct status by setting it to DRAFT Corrected spelling errors
2020-11-30	R20-11	AUTOSAR Release Management	Initial release

Disclaimer

This work (specification and/or software implementation) and the material contained in it, as released by AUTOSAR, is for the purpose of information only. AUTOSAR and the companies that have contributed to it shall not be liable for any use of the work.

The material contained in this work is protected by copyright and other types of intellectual property rights. The commercial exploitation of the material contained in this work requires a license to such intellectual property rights.

This work may be utilized or reproduced without any modification, in any form or by any means, for informational purposes only. For any other purpose, no part of the work may be utilized or reproduced, in any form or by any means, without permission in writing from the publisher.

The work has been developed for automotive applications only. It has neither been developed, nor tested for non-automotive applications.

The word AUTOSAR and the AUTOSAR logo are registered trademarks.

Table of Contents

1	Introduction	5
1.1	Overview	5
1.2	Abbreviations	5
1.3	Glossary of terms	5
1.4	Scope	8
1.5	Document conventions	8
1.6	Requirements Traceability	9
2	Timing Extensions Overview	11
3	Timing Views	14
3.1	Timing in Different Phases of the AUTOSAR Methodology	14
3.2	VfbTiming	15
3.3	SystemTiming	17
3.4	Machine Timing	18
3.5	Executable Timing	18
3.6	Service Timing	18
4	Timing Extensions Fundamentals	18
4.1	Formal Specification of Timing Behavior	19
4.2	Timing Extensions and Blueprints	19
4.3	Traceability of Constraints	21
4.4	Specifying Time Sets	21
5	Timing Description Events	21
5.1	Timing Events Related to the VFB	22
5.2	Timing Events related to Service Timing	30
5.3	Complex Timing Event	38
5.4	Occurrence Expression Language for Timing Events	39
5.4.1	Specifying an Occurrence Expression	40
5.4.2	Occurrence Expression Language Syntax	47
5.4.3	Interpreting an Occurrence Expression	48
5.4.3.1	Interpreting a Content Filter	48
5.4.3.2	Interpreting a Complex Event	49
6	Timing Description Event Chains	51
6.1	Approach	53
6.1.1	Decomposition	53
6.1.2	Composition	53
6.2	Patterns	55
6.2.1	Sequence	56
6.2.2	Fork	57
6.2.3	Join	57
6.2.4	Alternative	57

6.2.5	Cycle	59
7	Timing Constraints	60
7.1	EventTriggeringConstraint	61
7.1.1	PeriodicEventTriggering	62
7.1.1.1	Examples	64
7.1.2	SporadicEventTriggering	67
7.1.3	ConcretePatternEventTriggering	68
7.1.4	BurstPatternEventTriggering	71
7.1.5	ArbitraryEventTriggering	75
7.2	LatencyTimingConstraint	77
7.3	AgeConstraint	79
7.4	SynchronizationTimingConstraint	81
7.4.1	SynchronizationTimingConstraint on Event Chains	83
7.4.2	SynchronizationTimingConstraint on Events	85
7.5	OffsetTimingConstraint	87
A	Constraint History	89
A.1	Constraint and Specification Item History of this document according to AUTOSAR Release 20-11	89
A.1.1	Added Traceables in R20-11	89
A.1.2	Changed Traceables in R20-11	90
A.1.3	Deleted Traceables in R20-11	90
A.1.4	Added Constraints in R20-11	90
A.1.5	Changed Constraints in R20-11	91
A.1.6	Deleted Constraints in R20-11	91
A.2	Constraint and Specification Item History of this document according to AUTOSAR Release 21-11	91
A.2.1	Added Traceables in R21-11	91
A.2.2	Changed Traceables in R21-11	92
A.2.3	Deleted Traceables in R21-11	92
A.2.4	Added Constraints in R21-11	93
A.2.5	Changed Constraints in R21-11	94
A.2.6	Deleted Constraints in R21-11	94
B	Mentioned Class Tables	95
C	Splitable Elements in the Scope of this Document	107
D	Variation Points in the Scope of this Document	108

References

- [1] Requirements on Timing Extensions
 AUTOSAR_RS_TimingExtensions
- [2] Methodology for Adaptive Platform
 AUTOSAR_TR_AdaptiveMethodology
- [3] Virtual Functional Bus
 AUTOSAR_EXP_VFB
- [4] Standardization Template
 AUTOSAR_TPS_StandardizationTemplate
- [5] Generic Structure Template
 AUTOSAR_TPS_GenericStructureTemplate

1 Introduction

1.1 Overview

This AUTOSAR document contains the specification of the AUTOSAR Timing Extensions and describes the elements of the AUTOSAR meta-model used for creating timing models for the AUTOSAR *Adaptive* Platform. It is a supplement to the formal definition of the Timing Extensions by means of the AUTOSAR meta-model.

1.2 Abbreviations

<i>Abbreviation</i>	<i>Meaning</i>
ECU	Electronic Control Unit
I/O	Input/Output
SW-C	Software Component
TD	Timing Description
VFB	Virtual Functional Bus

1.3 Glossary of terms

<i>Term</i>	<i>Definition</i>
Jitter	For a periodically occurring timing event, the jitter is defined as the maximum variation of its period with respect to a predefined standard period.
Latency	The latency of a timing event chain describes the time duration between the occurrence of the stimulus and the occurrence of the corresponding response.

Maximum interarrival time	Describes the maximum time interval between two consecutive event occurrences. In the more general case, this attribute is an array of the maximum latency between two, three, four, ... event occurrences.
Minimum interarrival time	Describes the minimum time interval between two consecutive event occurrences. In the more general case, this attribute is an array of the minimum latency between two, three, four, ... event occurrences.
Period	Describes the expected time interval between two consecutive event occurrences, neglecting variation (jitter).
Response	End point of an event chain.
Synchronization	Synchronization focuses on the occurrence of different timing events. Synchronization of timing events means that they shall occur simultaneously within a certain tolerance interval.
Stimulus	Start point of an event chain.
Timing analysis	Timing analysis is a method of determining the timing behavior of the system. This includes consideration of timing relevant system behavior like task preemptions, interrupt handling, resource blocking, etc.
Timing constraint	A timing constraint may have two different interpretation alternatives. On the one hand, it may define a restriction for the timing behavior of the system (e.g. minimum (maximum) latency bound for a certain event sequence). In this case, a timing constraint is a requirement which the system shall fulfill. On the other hand, a timing constraint may define a guarantee for the timing behavior of the system. In this case, the system developer guarantees that the system has a certain behavior with respect to timing (e.g. a timing event is guaranteed to occur periodically with a certain maximum variation).
Timing description	The timing description of a system, subsystem or software component consists of events and event chains. The former one describes events that can be observed and the latter one describe their causal relationship.
Timing event	A timing event is the abstract representation of a specific system behavior – that can be observed at runtime – in the AUTOSAR specification. Timing events are used to define the scope for timing constraints. Depending on the specific scope, the view on the system, and the level of abstraction different types of events are defined.
Timing event chain	A timing event chain describes the causal order for a set of functionally dependent timing events. Each event chain has a well defined stimulus and response, which describe its start and end point. Furthermore, it can be hierarchically decomposed into an arbitrary number of sub-chains, so called "event chain segments".
Timing event occurrence	A timing event is said to "occur", when a specific system behavior – represented by the timing event – can be observed.
Timing guarantee	see glossary entry for "Timing constraint".
Timing information	Superordinate concept for timing properties and timing constraints.
Timing path	A timing path defines a sequence of communication or computation activities of the system, whose timing behavior shall be examined. Timing paths can be expressed by event chains.

Timing property	A timing property defines the state or value of a timing relevant aspect within the system. Thus, a property does not represent a constraint for the system, but a somehow gathered (e.g. measured, estimated or determined) or defined attribute of the system.
Timing requirement	A timing requirement defines a restriction on timing that shall be fulfilled to ensure proper operation of the system. Timing requirements can be expressed by using timing constraints.
Timing validation	Timing validation compares the result of timing analysis (see glossary entry for timing analysis) with the expected behavior defined by timing constraints (see glossary entry for timing constraints).

1.4 Scope

The primary purpose of the timing extensions is to support constructing embedded real-time systems that satisfy given timing requirements and to perform timing analysis/validations of those systems once they are operated.

The AUTOSAR Timing Extensions provide a timing model as specification basis for a contract based development process, in which the development is carried out by different organizations in different locations and time frames. The constraints entered in the early phase of the project (when corresponding solutions are not developed yet) shall be seen as extra-functional requirements agreed between the development partners. In such way the timing specification supports a top-down design methodology. However, due to the fact that a pure top-down design is not feasible in most of the cases (e.g. because of legacy code), the timing specification allows the bottom-up design methodology as well.

The resulting overall specification (AUTOSAR Model *and* Timing Extensions) shall enable the analysis of a system's timing behavior and the validation of the analysis results against timing constraints. Thus, timing properties required for the analysis shall be contained in the timing augmented system model. Such timing properties can be found all across AUTOSAR. For example the System Template provides means to configure and specify the timing behavior of the communication stack. Furthermore the execution time of an executable can be specified. In addition, the overall specification shall provide means to describe timing constraints. A timing constraint defines a restriction for the timing behavior of the system (e.g. bounding the maximum latency from sensor sampling to actuator access). Timing constraints are added to the system model using the AUTOSAR Timing Extensions. Constraints, together with the result of timing analysis, are considered during the validation of a system's timing behavior, when a nominal/actual value comparison is performed.

Note: The timing specification shall enable the analysis and validation of an AUTOSAR system's timing behavior. However, the specification of analysis and validation results, like for example the maximum resource utilization of an ECU, is not addressed in this document.

1.5 Document conventions

Technical terms (Meta Class Names) are typeset in monospaced font, e.g. `AdaptiveApplicationSwComponentType`.

1.6 Requirements Traceability

The following table references the requirements specified in AUTOSAR RS Timing Extensions [1] and denotes how each of them are satisfied by the meta-model.

Requirement	Description	Satisfied by
[RS_TIMEX_00001]	Timing properties	[TPS_TIMEX_00058] [TPS_TIMEX_00059] [TPS_TIMEX_00060] [TPS_TIMEX_00061] [TPS_TIMEX_00062] [TPS_TIMEX_00063] [TPS_TIMEX_00064] [TPS_TIMEX_00065] [TPS_TIMEX_00069] [TPS_TIMEX_00070] [TPS_TIMEX_00071] [TPS_TIMEX_00072] [TPS_TIMEX_00073] [TPS_TIMEX_00074] [TPS_TIMEX_00076] [TPS_TIMEX_00077] [TPS_TIMEX_00078] [TPS_TIMEX_00079] [TPS_TIMEX_00080] [TPS_TIMEX_00081] [TPS_TIMEX_00082] [TPS_TIMEX_00083] [TPS_TIMEX_00084] [TPS_TIMEX_00085] [TPS_TIMEX_00086] [TPS_TIMEX_00087] [TPS_TIMEX_00088] [TPS_TIMEX_00090] [TPS_TIMEX_00092] [TPS_TIMEX_00093]
[RS_TIMEX_00002]	Timing constraints	[TPS_TIMEX_00071] [TPS_TIMEX_00072] [TPS_TIMEX_00074] [TPS_TIMEX_00076] [TPS_TIMEX_00077] [TPS_TIMEX_00078] [TPS_TIMEX_00079] [TPS_TIMEX_00080] [TPS_TIMEX_00081]
[RS_TIMEX_00003]	Optionality of timing constraints	[TPS_TIMEX_00075]
[RS_TIMEX_00004]	Event chains	[TPS_TIMEX_00070]
[RS_TIMEX_00005]	Structure of event chains	[TPS_TIMEX_00070]
[RS_TIMEX_00006]	Triggering behavior of event chains	[TPS_TIMEX_00071] [TPS_TIMEX_00076] [TPS_TIMEX_00077] [TPS_TIMEX_00078] [TPS_TIMEX_00079] [TPS_TIMEX_00080]
[RS_TIMEX_00007]	Synchronization of event chains	[TPS_TIMEX_00074]

[RS_TIMEX_00008]	Multiple asynchronous time bases	[TPS_TIMEX_00071] [TPS_TIMEX_00074] [TPS_TIMEX_00076] [TPS_TIMEX_00077] [TPS_TIMEX_00078] [TPS_TIMEX_00079] [TPS_TIMEX_00080] [TPS_TIMEX_00081]
[RS_TIMEX_00010]	Validity of timing properties and constraints	[TPS_TIMEX_00089]
[RS_TIMEX_00012]	Sensor/actuator delay	[TPS_TIMEX_00072]
[RS_TIMEX_00016]	Some elements of the Timing Extensions shall be blueprintable	[TPS_TIMEX_00091]
[RS_TIMEX_00017]	Synchronization constraint on events	[TPS_TIMEX_00074]
[RS_TIMEX_00019]	AUTOSAR Methodology support	[TPS_TIMEX_00092] [TPS_TIMEX_00093]
[RS_TIMEX_00024]	Support for Service Oriented Communication	[TPS_TIMEX_00058] [TPS_TIMEX_00059] [TPS_TIMEX_00060] [TPS_TIMEX_00061] [TPS_TIMEX_00062] [TPS_TIMEX_00063] [TPS_TIMEX_00064] [TPS_TIMEX_00065]

Table 1.1: Requirements Tracing

2 Timing Extensions Overview

The AUTOSAR Timing Extensions provide some basic means to describe and specify timing information: Timing descriptions, expressed by *events* and *event chains*, and *timing constraints* that are imposed on these events and event chains. Both means, timing descriptions and timing constraints, are organized in *timing views* for specific purposes. By and large, the purpose of the Timing Extensions are two fold: The first purpose is to provide timing requirements that guide the construction of systems which eventually shall satisfy those timing requirements. And the second purpose is to provide sufficient timing information to analyze and validate the temporal behavior of a system.

Events. Events refer to locations in systems at which the *occurrences* of events are observed. The AUTOSAR Specification of Timing Extensions defines a set of predefined event types for such *observable locations*. Those event types are used in different *timing views* and each of these timing views correspond to one of the AUTOSAR platform views: *VFB Timing* and Virtual Functional Bus (VFB) View, *System Timing* and System View, *Machine Timing* and Machine View, *Executable Timing* and Executable View, as well as *Service Timing* and Service View.

In the adaptive platform, these events specify the usage and operation of services in timing views such VFB, System, Machine, Executable and Service Timing.

Event Chains. Event chains specify a causal relationship between events and their temporal occurrences. The notion of event chain enables one to specify the relationship between two events, for example when an event A occurs then the event B occurs, or in other words, the event B occurs if and only if the event A occurred before. In the context of an event chain the event A plays the role of the *stimulus* and the event B plays the role of the *response*. Event chains can be composed of existing event chains and decomposed into further event chains — in both cases the event chains play the role of *event chain segments*.

Timing Constraints imposed on Events. The notion of *event* is used to describe that in a system specific events occur and also at which locations in this system the occurrences are observed. In addition, an Event Triggering Constraint imposes a constraint on the occurrences of an event, which means that the event triggering constraint specifies the way an event occurs in the temporal space. The AUTOSAR Specification of Timing Extensions provides means to specify periodic and sporadic event occurrences, as well as event occurrences that follow a specific pattern (burst, concrete, and arbitrary pattern).

Timing Constraints imposed on Event Chains. Like event triggering constraints impose timing constraints on events and their occurrences; the latency and synchronization timing constraints impose constraints on event chains. In the former case, a constraint is used to specify a reaction and age, for example if a stimulus event occurs then the corresponding response event shall occur not later than a given amount of time. And in the latter case, the constraint is used to specify that stimuli or response

events shall occur within a given time interval (tolerance) to be said to occur simultaneous and synchronous respectively.

The concepts sketched so far are represented by the meta-model shown in Figure 2.1. And every part is described in the subsequent chapters and sections.

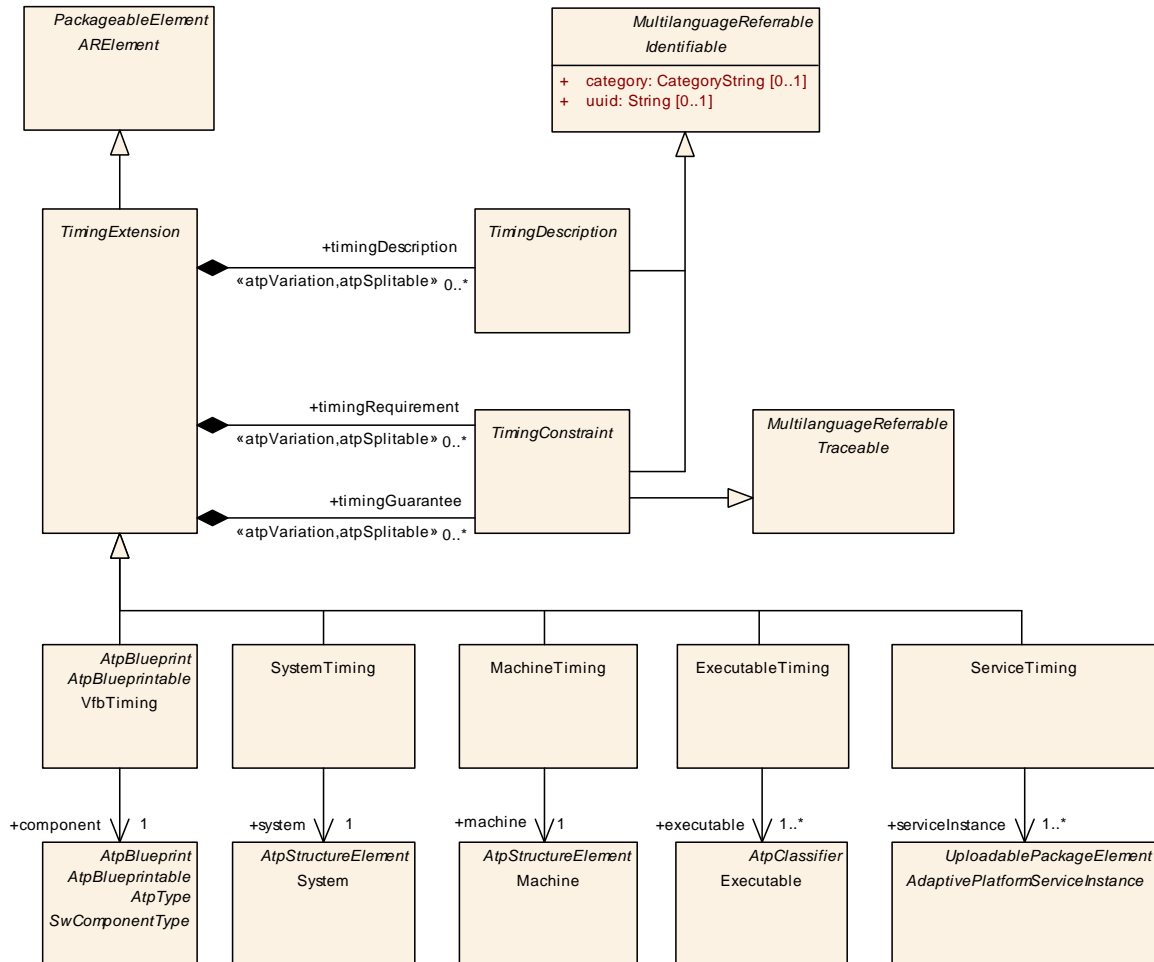

Figure 2.1: Overview of the Timing Extensions for the adaptive platform including Timing Descriptions, Timing Constraints, and Timing Views.

Class	<i>TimingExtension</i> (abstract)			
Package	M2::AUTOSARTemplates::CommonStructure::Timing			
Note	The abstract parent class of the different template specific timing extensions. Depending on the specific timing extension the timing descriptions and timing constraints, that can be used to specify the timing behavior, are restricted.			
Base	<i>ARElement</i> , <i>ARObject</i> , <i>CollectableElement</i> , <i>Identifiable</i> , <i>MultilanguageRefferable</i> , <i>PackageableElement</i> , <i>Refferable</i>			
Subclasses	ExecutableTiming , MachineTiming , ServiceTiming , SystemTiming , VfbTiming			
Attribute	Type	Mult.	Kind	Note





Class	TimingExtension (abstract)			
timingCondition	TimingCondition	*	aggr	The timing condition specifies a specific condition. Stereotypes: atpSplitable; atpVariation Tags: atp.Splitkey=timingCondition.shortName, timingCondition.variationPoint.shortLabel vh.latestBindingTime=postBuild
timingDescription	TimingDescription	*	aggr	The timing descriptions that belong to a specific timing specification. In order to support different timing description variants within a timing specification, the aggregation is marked with the stereotype "atpVariation". Stereotypes: atpSplitable; atpVariation Tags: atp.Splitkey=timingDescription.shortName, timingDescription.variationPoint.shortLabel vh.latestBindingTime=postBuild
timingGuarantee	TimingConstraint	*	aggr	The timing constraints that belong to a specific timing specification in the role of a timing guarantee. In order to support different timing constraint variants within a timing specification, the aggregation is marked with the stereotype "atpVariation". Stereotypes: atpSplitable; atpVariation Tags: atp.Splitkey=timingGuarantee.shortName, timingGuarantee.variationPoint.shortLabel vh.latestBindingTime=postBuild
timingRequirement	TimingConstraint	*	aggr	The timing constraints that belong to a specific timing specification in the role of a timing requirement. In order to support different timing constraint variants within a timing specification, the aggregation is marked with the stereotype "atpVariation". Stereotypes: atpSplitable; atpVariation Tags: atp.Splitkey=timingRequirement.shortName, timingRequirement.variationPoint.shortLabel vh.latestBindingTime=postBuild
timingResource	TimingExtensionResource	0..1	aggr	The timing resource contains all instance references referred from within a timing condition formula of a timing view. Stereotypes: atpSplitable Tags: atp.Splitkey=timingResource.shortName

Table 2.1: TimingExtension

Class	TimingDescription (abstract)			
Package	M2::AUTOSARTemplates::CommonStructure::Timing::TimingDescription			
Note	The abstract parent class of the model elements that are used to define the scope of a timing constraint.			
Base	ARObject, Identifiable, MultilanguageReferrable, Referrable			
Subclasses	TimingDescriptionEvent, TimingDescriptionEventChain			
Attribute	Type	Mult.	Kind	Note
–	–	–	–	–

Table 2.2: TimingDescription

Class	<i>TimingConstraint</i> (abstract)			
Package	M2::AUTOSARTemplates::CommonStructure::Timing::TimingConstraint			
Note	The abstract parent class of different timing constraints supported by the Timing extension. A concrete timing constraint is used to bound the timing behavior of the model elements in its scope.			
Base	<i>ARObject</i> , <i>Identifiable</i> , <i>MultilanguageReferrable</i> , <i>Referrable</i> , <i>Traceable</i>			
Subclasses	AgeConstraint , EventTriggeringConstraint , LatencyTimingConstraint , OffsetTimingConstraint , SynchronizationTimingConstraint			
Attribute	Type	Mult.	Kind	Note
timingCondition	TimingCondition	0..1	ref	A timing condition the timing constraint depends on. In other words it specifies the condition the timing constraint holds.

Table 2.3: TimingConstraint

3 Timing Views

The AUTOSAR Timing Extensions define five distinct timing views. Each of these views is associated with one of the AUTOSAR views, namely Virtual Functional Bus-, System-, Machine-, Executable- and Service view. Figure 2.1 provides an overview of the AUTOSAR Timing Extensions and its basic elements including the timing views.

This chapter outlines the timing views that are used in the different phases of the AUTOSAR methodology in order to create appropriate timing models.

3.1 Timing in Different Phases of the AUTOSAR Methodology

The AUTOSAR methodology [2] provides several well-defined process steps, and artifacts that are provided or needed by these steps.

VfbTiming This view deals with timing information related to the interaction of [AdaptiveApplicationSwComponentTypes](#) at VFB level.

SystemTiming This view deals with timing information related to a [System](#), utilizing information about topology, software deployment, and signal mapping.

MachineTiming This view deals with timing information related to a [Machine](#).

ExecutableTiming This view deals with timing information related to an [Executable](#).

ServiceTiming This view deals with timing information related to a *service*, specifically [AdaptivePlatformServiceInstance](#).

For each of these views a special focus of timing specification can be applied, depending on the availability of necessary information, the role a certain artifact is playing and the development phase, which is associated with the view.

The following sections give a detailed overview of every timing view and their relevance for timing specification. For each view it is explained what kind of timing description and timing constraints can be applied and to which AUTOSAR specification documents these can be attached to.

3.2 VfbTiming

AUTOSAR defines the *Virtual Functional Bus* [3] as a composition of *SwComponentPrototypes* at a logical level, regardless of their physical distribution. On this logical level a special view can be applied for timing specification. This section describes what kind of timing specification can be applied at VFB level for a system or sub-system. Typically, end-to-end timing constraints, including (physical) sensors and actuators, shall be captured in this view, allowing an early formalization of those constraints.

Neglecting the physical distribution means that the *VfbTiming* view does not deal with the question, in which system context the prototype of a *CompositionSwComponentType* shall be implemented. An additional restriction of the *VfbTiming* view is present due to the black box treatment of software components. The *AdaptiveSwcInternalBehavior* of *AdaptiveApplicationSwComponentTypes* is not considered. For these mentioned restrictions (irrelevance of the physical distribution, black box view), *TimingDescriptions* at VFB level should only refer to *SwComponentTypes*, *PortPrototypes* and their connections, but not the *AdaptiveSwcInternalBehavior*.

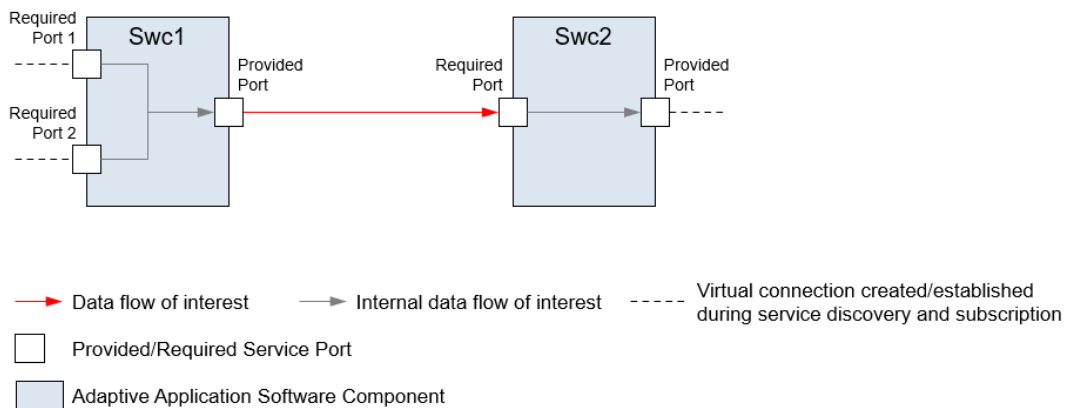

Figure 3.1: Data flow in the scope of the VfbTiming view

The *VfbTiming* view is applicable for different system granularities. The smallest granularity is the investigation of a single *SwComponentType* without any contextual embedding. Here, a timing description can only refer to relations between a component's *RPortPrototypes* and the same component's *PPortPrototypes*.

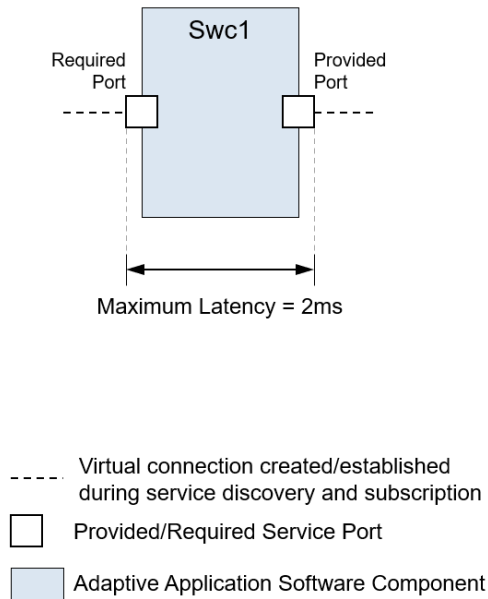

Figure 3.2: Latency requirement

As an example, consider the timing constraint illustrated in Figure 3.2: "From the point in time, where the data value is received via the required service port of the adaptive application software component named *Swc1*, until the point in time, where the newly calculated data value is sent via the provided service port, there shall be a maximum latency of 2 ms". This would be attached to the timing description that refers to an [AdaptiveApplicationSwComponentType](#) called *Swc1*.

[TPS_TIMEX_00087]{DRAFT} Purpose of [VfbTiming](#) [The element [VfbTiming](#) aggregates all timing information, timing descriptions and timing constraints, that is related to the VFB View.] ([RS_TIMEX_00001](#))

Class	VfbTiming			
Package	M2::AUTOSARTemplates::CommonStructure::Timing			
Note	A model element used to define timing descriptions and constraints at VFB level. TimingDescriptions aggregated by VfbTiming are restricted to event chains referring to events which are derived from the class TDEventVfb. Tags: atp.recommendedPackage=TimingExtensions			
Base	ARElement , ARObject , AtpBlueprint , AtpBlueprintable , CollectableElement , Identifiable , Multilanguage , Referrable , PackageableElement , Referrable , TimingExtension			
Attribute	Type	Mult.	Kind	Note
component	SwComponentType	1	ref	This defines the scope of a VfbTiming. All corresponding timing descriptions and constraints shall be defined within this scope.

Table 3.1: VfbTiming

3.3 SystemTiming

At system level a special prototype of a `CompositionSwComponentType`—the `RootSwComponentPrototype`—is instantiated. This prototype, the chosen hardware topology and other artifacts are used as input to the task dealing with the deployment of software components onto machines in order to configure the system. The main configuration result is the mapping of software components to ECUs and in further steps the resulting communication matrix is created. This information is aggregated in the `System` description.

The `SystemTiming` view is used to provide timing information at system level. As an extension, it can be attached to a `System`. As the `System` description aggregates all the information about `AdaptiveApplicationSwComponentTypes` and their corresponding `AdaptiveSwcInternalBehavior`, it is possible to use the same concepts that are available in the view `VfbTiming` also in this timing view. The difference is the specific system context that defines the validity of timing information at system level. Without knowledge of the mapping of software components to a target hardware respectively ECU, only a generic platform independent description can be provided.

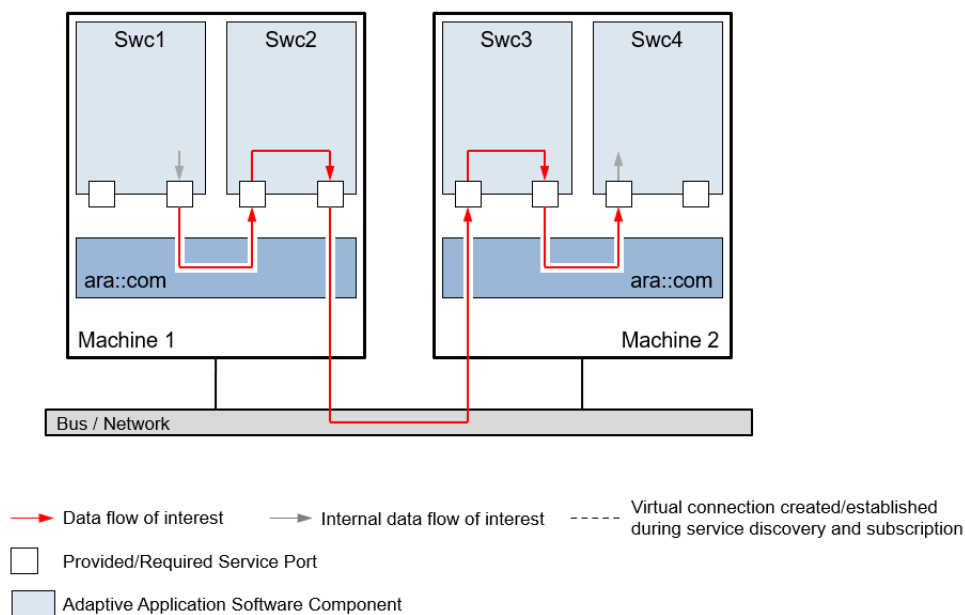

Figure 3.3: Data flow in the scope of System Timing view

In addition, a timing description in system view refers to the concrete communication of software components that only was represented as abstract connectors in `VfbTiming` view. Due to the software mapping, now communication is either local communication within a machine, or remote communication between machines across a communication bus. A system-specific timing description thus can refer to signals and frames sent across a physical network.

[TPS_TIMEX_00088]{DRAFT} **Purpose of SystemTiming** [The element [SystemTiming](#) aggregates all timing information, timing descriptions and timing constraints, that is related to the System View.] ([RS_TIMEX_00001](#))

Class	SystemTiming			
Package	M2::AUTOSARTemplates::CommonStructure::Timing			
Note	<p>A model element used to refine timing descriptions and constraints (from a VfbTiming) at System level, utilizing information about topology, software deployment, and signal mapping described in the System Template.</p> <p>TimingDescriptions aggregated by SystemTiming are restricted to events which are derived from the class TDEventVfb, TDEventSwcInternalBehavior and TDEventCom.</p> <p>Tags:atp.recommendedPackage=TimingExtensions</p>			
Base	ARElement , ARObject , CollectableElement , Identifiable , MultilanguageReferrable , PackageableElement , Referrable , TimingExtension			
Attribute	Type	Mult.	Kind	Note
system	System	1	ref	This defines the scope of a SystemTiming. All corresponding timing descriptions and constraints shall be defined within this scope.

Table 3.2: SystemTiming

3.4 Machine Timing

[TPS_TIMEX_00063]{DRAFT} **Purpose of MachineTiming** [The element [MachineTiming](#) aggregates all timing information, timing descriptions and timing constraints, that is related to the Machine View.] ([RS_TIMEX_00001](#), [RS_TIMEX_00024](#))

3.5 Executable Timing

[TPS_TIMEX_00064]{DRAFT} **Purpose of ExecutableTiming** [The element [ExecutableTiming](#) aggregates all timing information, timing descriptions and timing constraints, that is related to the Executable View.] ([RS_TIMEX_00001](#), [RS_TIMEX_00024](#))

3.6 Service Timing

[TPS_TIMEX_00065]{DRAFT} **Purpose of ServiceTiming** [The element [ServiceTiming](#) aggregates all timing information, timing descriptions and timing constraints, that is related to the Service View.] ([RS_TIMEX_00001](#), [RS_TIMEX_00024](#))

4 Timing Extensions Fundamentals

This section explains the fundamental capabilities of the AUTOSAR Timing Extension.

4.1 Formal Specification of Timing Behavior

Compared to the specification of a system's functional behavior, the specification of its timing behavior requires additional information to be captured. Not only the eventual occurrence of events but also their exact timing or the concurrency of various events become important. Therefore, in the specification of timing extensions for AUTOSAR, the *event* is the basic entity. This event is used to refer to an observable behavior within a system at a certain point in time.

Having to deal with different abstraction levels and views (see chapter 3), and in order to avoid semantic confusion with existing concepts, a new abstract type `TimingDescriptionEvent` (see section 5) is introduced as a formal basis for the timing extensions. Depending on the model entity and the associated observable behavior, specific timing events are defined and linked to the different views.

For the analysis of a system's timing behavior usually not only single events but also the correlation of different events is of fundamental importance. To relate timing events to each other, a further concept called `TimingDescriptionEventChain` (see section 6) is introduced. Hereby, it is important to note that for the referenced events of an event chain a functional dependency is implicitly assumed. This means that an event of a chain somehow causes subsequent chain events.

Based on events and event chains, it is possible to express various specific timing constraints derived from the abstract type `TimingConstraint`. These timing constraints specify the expected timing behavior. As timing constraints shall be valid independently from implementation details, they are also expressed on an abstract level by referencing the above introduced formal basis of `TimingDescriptionEvents` and `TimingDescriptionEventChains`.

Thus, by means of events, event chains and timing constraints defined on top of these, a separate central timing specification can be provided, decoupling the expected timing behavior from the actually implemented behavior. This approach supports timing contracts for AUTOSAR systems in a top-down as well as bottom-up approach.

[TPS_TIMEX_00075]{DRAFT} Optional use of timing extensions [The elements `TimingExtension`, `TimingDescription`, and `TimingConstraint` of the timing extensions are derived from the element `ARElement`. This enables one to deliver timing extensions in a separate document. In addition, there are no external references from any template that point to timing extensions elements.] ([RS_TIMEX_00003](#))

4.2 Timing Extensions and Blueprints

[TPS_TIMEX_00091]{DRAFT} Blueprinting `vfbTiming` [`vfbTiming` can be blueprinted.] ([RS_TIMEX_00016](#))

The primary purpose of blueprinting `vfbTiming` is to annotate Application Interfaces and attach timing constraints, like age- and periodic event triggering constraints, to

events of type `TDEventVfb` which reference port prototype blueprints. The concept of Blueprints and its details are described in [4].

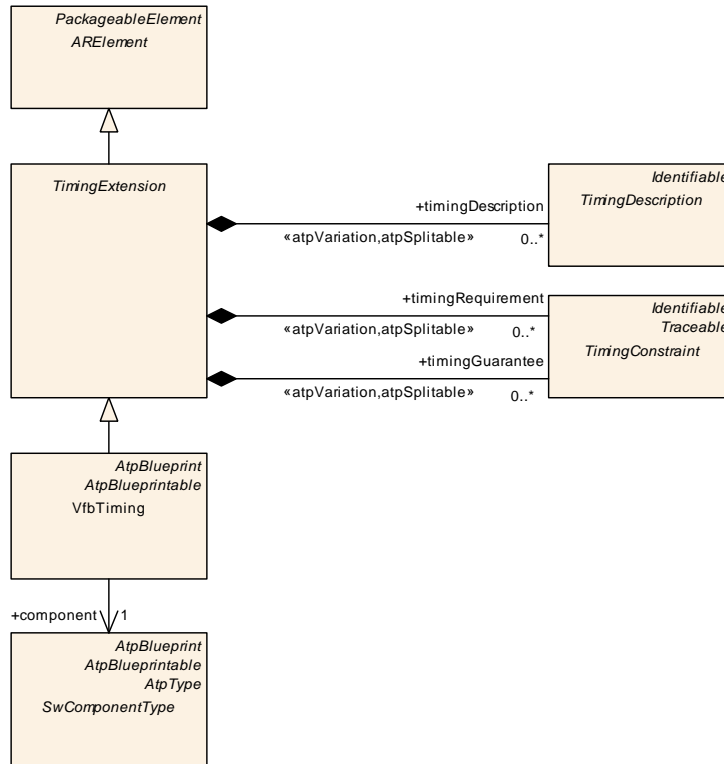

Figure 4.1: VFB Timing Blueprint

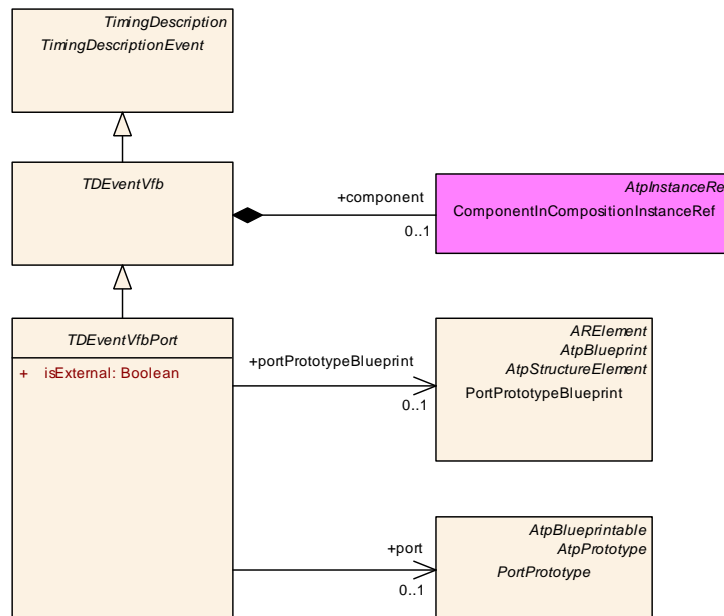

Figure 4.2: TDEventVfb Blueprint

[constr_4577]{DRAFT} TDEventVfb shall reference PortPrototypeBlueprint only in Blueprints [An event type `TDEventVfb` only shall reference `PortPrototypeBlueprint` in blueprints.]()

[constr_4578]{DRAFT} Only **VfbTiming** shall be a **Blueprint** [Only the **VfbTiming** is blueprintable.]()

4.3 Traceability of Constraints

[TPS_TIMEX_00089]{DRAFT} **TimingConstraint** is a **Traceable** [The element **TimingConstraint** and all of its specializations, commonly called timing constraints, are traceable.](*RS_TIMEX_00010*)

The support for traceability [4] enables one to specify relationships between timing constraints and corresponding AUTOSAR elements that satisfy those timing requirements.

4.4 Specifying Time Sets

Sometimes it is necessary to specify that there are several alternatives with regard to timing requirements. For example, quite often it is reasonable to specify that a process shall be periodically activated either at 1ms, 2ms, 5ms, 8ms, or 10ms. In other words, it is perfectly fine to decide that the process is activated every 8ms. Indeed, it is allowed to activate the process either at 1ms, 2ms, 5ms, 8ms, or 10ms. Hence, there should be a means to specify such time sets which contain all allowed timings, like in case of activating a process at {1, 2, 5, 8, 10} ms.

For the purpose of specifying time sets the timing extensions utilize the "Variant Handling" capabilities specified and described in [5].

5 Timing Description Events

[TPS_TIMEX_00069]{DRAFT} **Purpose of TimingDescriptionEvent** [The element **TimingDescriptionEvent** and its specializations are used to describe the occurrences of an event which are observed at a specific location in a system during runtime respectively the operation of the system.](*RS_TIMEX_00001*)

For example, this can be the start of a service or the different steps in executing an executable.

An overview of the different event types is given in Figure 5.1. These are described in more detail in the following sub-chapters.

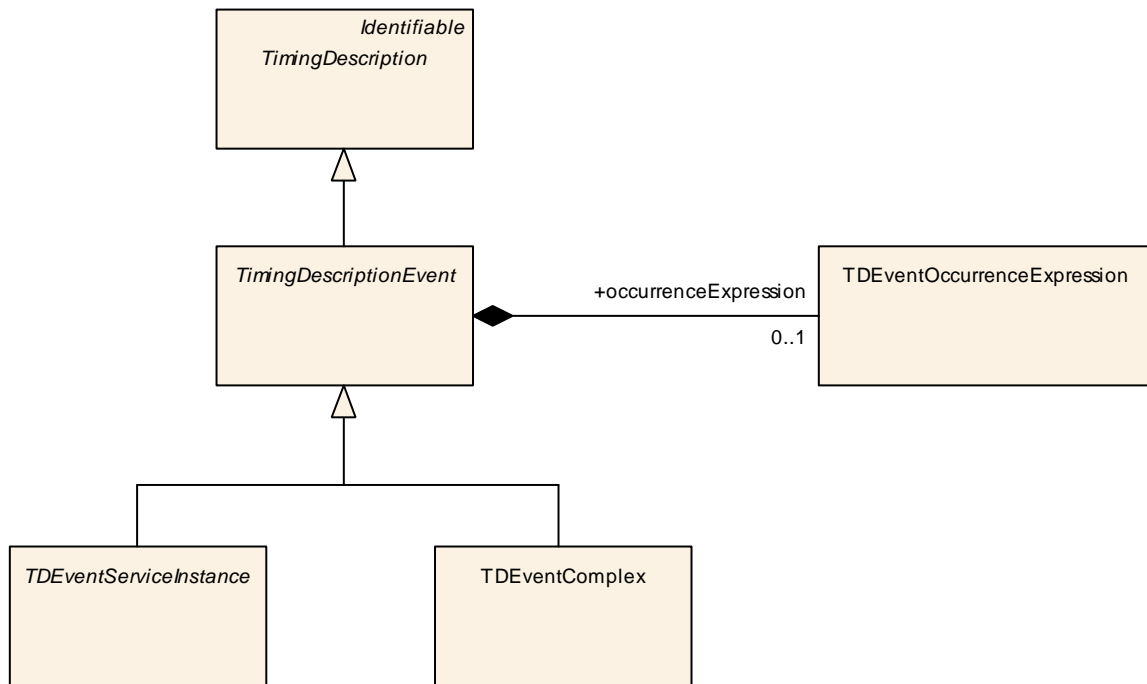

Figure 5.1: Overview of the different types of timing events

Class	<i>TimingDescriptionEvent</i> (abstract)			
Package	M2::AUTOSARTemplates::CommonStructure::Timing::TimingDescription			
Note	<p>A timing event is the abstract representation of a specific system behavior – that can be observed at runtime – in the AUTOSAR specification. Timing events are used to define the scope for timing constraints. Depending on the specific scope, the view on the system, and the level of abstraction different types of events are defined.</p> <p>In order to avoid confusion with existing event descriptions in the AUTOSAR templates the timing specific event types use the prefix TD.</p>			
Base	<i>ARObject</i> , <i>Identifiable</i> , <i>MultilanguageReferrable</i> , <i>Referrable</i> , <i>TimingDescription</i>			
Subclasses	<i>TDEventCom</i> , <i>TDEventComplex</i> , <i>TDEventServiceInstance</i> , <i>TDEventVfb</i>			
Attribute	Type	Mult.	Kind	Note
occurrence Expression	TDEventOccurrenceExpression	0..1	aggr	The occurrence expression for this event.

Table 5.1: TimingDescriptionEvent

Also note that information regarding the occurrence of a [TimingDescriptionEvent](#) is described separately in section 7.1.

5.1 Timing Events Related to the VFB

[TPS_TIMEX_00082]{DRAFT} **Purpose of [TDEventVfb](#)** [The element [TDEventVfb](#) and its specializations are used to describe the occurrences of an event which are observed at a specific location in the VFB view.]([RS_TIMEX_00001](#))

Events related to the VFB can be used during the specification of:

- [VfbTiming 3.2](#)

• [SystemTiming 3.3](#)

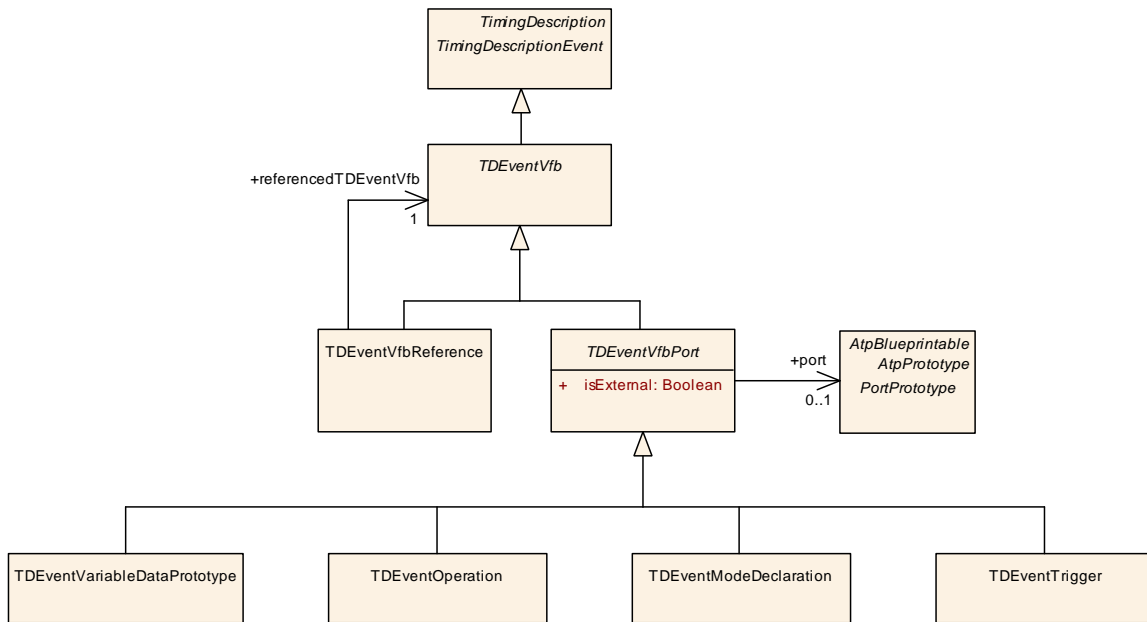

Figure 5.2: VFB events

Class	TDEventVfb (abstract)			
Package	M2::AUTOSARTemplates::CommonStructure::Timing::TimingDescription::TimingDescriptionEvents::TDEventVfb			
Note	This is the abstract parent class to describe timing events at Virtual Functional Bus (VFB) level.			
Base	ARObject, Identifiable, MultilanguageReferrable, Referrable, TimingDescription, TimingDescriptionEvent			
Subclasses	TDEventVfbPort, TDEventVfbReference			
Attribute	Type	Mult.	Kind	Note
component	SwComponent Prototype	0..1	iref	The context for the scope of this timing event. InstanceRef implemented by: ComponentInComposition InstanceRef

Table 5.2: TDEventVfb

[TPS_TIMEX_00092]{DRAFT} **Purpose of TDEventVfbPort** [The element `TDEventVfbPort` and its specializations are used to describe the occurrences of an event which are observed at a specific location in the VFB view.] ([RS_TIMEX_00001](#), [RS_TIMEX_00019](#))

Class	TDEventVfbPort (abstract)			
Package	M2::AUTOSARTemplates::CommonStructure::Timing::TimingDescription::TimingDescriptionEvents::TDEventVfb			
Note	This is the abstract parent class to describe specific timing event types at Virtual Functional Bus (VFB) level.			
Base	ARObject, Identifiable, MultilanguageReferrable, Referrable, TDEventVfb, TimingDescription, TimingDescriptionEvent			
Subclasses	TDEventModeDeclaration, TDEventOperation, TDEventTrigger, TDEventVariableDataPrototype			
Attribute	Type	Mult.	Kind	Note





Class	TDEventVfbPort (abstract)			
isExternal	Boolean	1	attr	This attribute is used to refer to external events that are related to hardware I/O, like physical sensors and actuators, at Virtual Functional Bus (VFB) level.
port	PortPrototype	0..1	ref	The port scope of the timing event.
portPrototypeBlueprint	PortPrototypeBlueprint	0..1	ref	The PortPrototypeBlueprint is the scope of the timing event.

Table 5.3: TDEventVfbPort

In order to support the description of timing events for hardware I/O already at VFB-level (e.g. in order to refer to the point in time where data is generated by a physical sensor) without having the need to specify the concrete sensor hardware, it is necessary to specify the attribute `isExternal`.

If for a timing event of type `TDEventVfbPort` the attribute is set to "TRUE", then the timing event refers to the point in time where the data is generated/processed by the corresponding hardware I/O.

If the attribute is set to "FALSE", then the timing event refers to the point in time where the data enters or leaves the respective port of the component at VFB-level.

[TPS_TIMEX_00093]{DRAFT} Purpose of `TDEventVfbReference` [The element `TDEventVfbReference` is used to reference timing description events already specified in other timing views. In other words, it enables one to re-use existing timing models.] ([RS_TIMEX_00001](#), [RS_TIMEX_00019](#))

Class	TDEventVfbReference			
Package	M2::AUTOSARTemplates::CommonStructure::Timing::TimingDescription::TimingDescriptionEvents::TDEventVfb			
Note	This is used to reference timing description events related to the Virtual Functional Bus (VFB) view which are specified in other timing views.			
Base	<i>ARObject</i> , <i>Identifiable</i> , <i>MultilanguageReferrable</i> , <i>Referrable</i> , TDEventVfb , TimingDescription , TimingDescriptionEvent			
Attribute	Type	Mult.	Kind	Note
referencedTDEventVfb	TDEventVfb	1	ref	The referenced timing description event.

Table 5.4: TDEventVfbReference

[TPS_TIMEX_00083]{DRAFT} `TDEventVariableDataPrototype` specifies events observable at sender/receiver ports [The element `TDEventVariableDataPrototype` is used to specify events, namely the receipt and sending of variable data prototypes, observable at required and provided sender/receiver ports.] ([RS_TIMEX_00001](#))

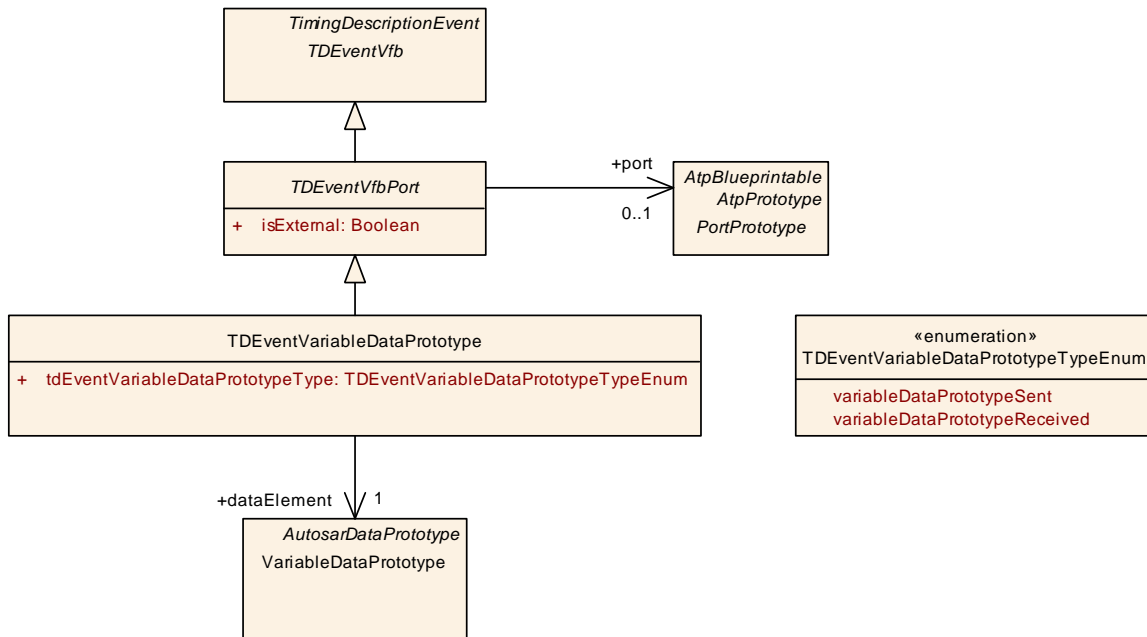

Figure 5.3: Variable Data Prototype

Class	TDEventVariableDataPrototype			
Package	M2::AUTOSARTemplates::CommonStructure::Timing::TimingDescription::TimingDescriptionEvents::TDEventVfb::VariableDataPrototype			
Note	This is used to describe timing events related to sender-receiver communication at VFB level.			
Base	ARObject, Identifiable, MultilanguageReferrable, Referrable, TDEventVfb, TDEventVfbPort, TimingDescription, TimingDescriptionEvent			
Attribute	Type	Mult.	Kind	Note
dataElement	VariableDataPrototype	1	ref	The referenced VariableDataPrototype
tdEventVariableDataPrototypeType	TDEventVariableDataPrototypeTypeEnum	1	attr	The specific type of this timing event.

Table 5.5: TDEventVariableDataPrototype

Enumeration	TDEventVariableDataPrototypeTypeEnum	
Package	M2::AUTOSARTemplates::CommonStructure::Timing::TimingDescription::TimingDescriptionEvents::TDEventVfb::VariableDataPrototype	
Note	This is used to describe the specific event type of a TDEventVariableDataPrototype	
Literal	Description	
variableDataPrototypeReceived	A point in time where the referenced variable data prototype has been successfully transmitted and is available in the related communication buffer (of the RTE) for the receiving SWC. Tags: atp.EnumerationLiteralIndex=0	
variableDataPrototypeSent	A point in time where the referenced variable data prototype has been successfully sent out by the sending SWC, so that it is available in the related communication buffer (of the RTE) for transmission. Tags: atp.EnumerationLiteralIndex=1	

Table 5.6: TDEventVariableDataPrototypeTypeEnum

[TPS_TIMEX_00084]{DRAFT} **TDEventOperation** specifies events observable at client/server ports. [The element **TDEventOperation** is used to specify events,

namely the invocation of operations and their completion, observable at required and provided client/server ports.](RS_TIMEX_00001)

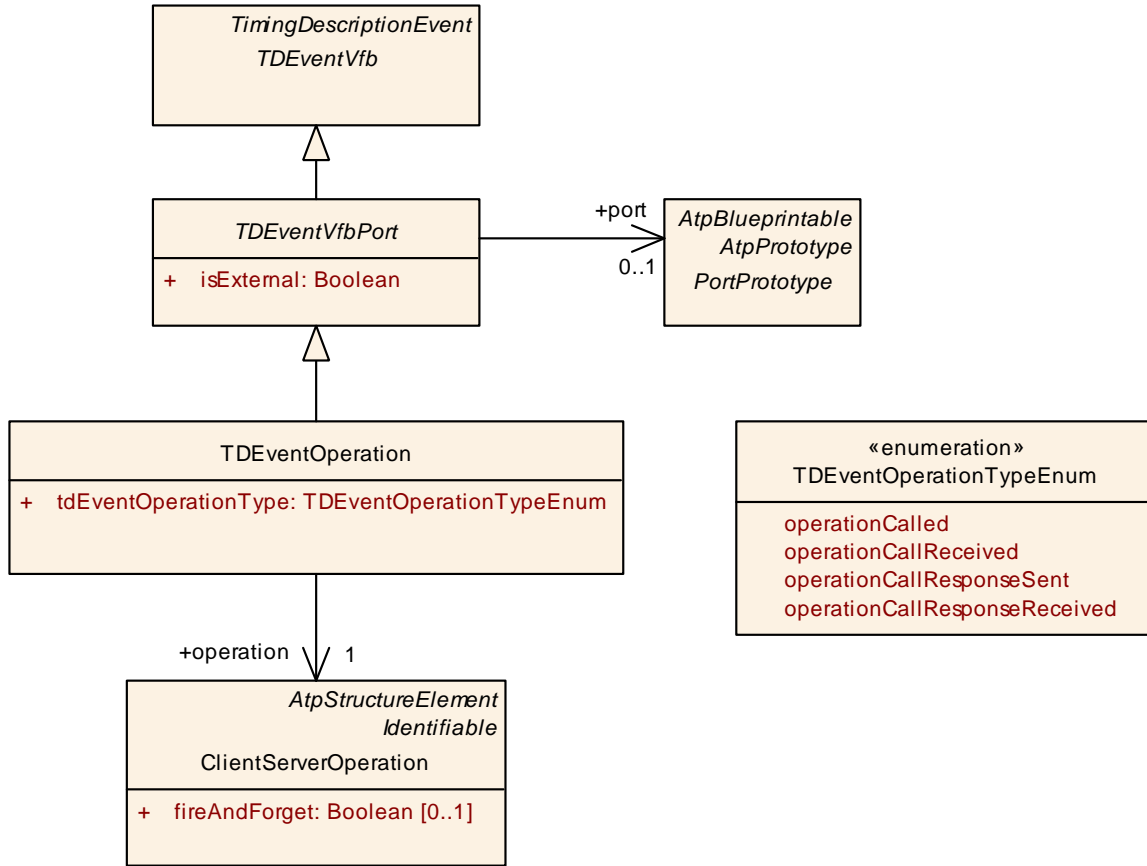

Figure 5.4: Operation

Class	TDEventOperation			
Package	M2::AUTOSARTemplates::CommonStructure::Timing::TimingDescription::TimingDescriptionEvents::TDEventVfb::Operation			
Note	This is used to describe timing events related to client-server communication at VFB level.			
Base	ARObject, Identifiable, MultilanguageReferrable, Referrable, TDEventVfb, TDEventVfbPort, TimingDescription, TimingDescriptionEvent			
Attribute	Type	Mult.	Kind	Note
operation	ClientServerOperation	1	ref	The referenced operation.
tdEventOperationType	TDEventOperationTypeEnum	1	attr	The specific type of this timing event.

Table 5.7: TDEventOperation

Enumeration	TDEventOperationTypeEnum
Package	M2::AUTOSARTemplates::CommonStructure::Timing::TimingDescription::TimingDescriptionEvents::TDEventVfb::Operation
Note	This is used to describe the specific event type of a TDEventOperation.
Literal	Description





Enumeration	TDEventOperationTypeEnum
operationCalled	A point in time where the referenced operation is called by the client SWC. Tags: atp.EnumerationLiteralIndex=0
operationCallReceived	A point in time where the call of the referenced operation is received by the server SWC. Tags: atp.EnumerationLiteralIndex=1
operationCallResponseReceived	A point in time where the client SWC has received the response of the referenced operation call. Tags: atp.EnumerationLiteralIndex=2
operationCallResponseSent	A point in time where the server SWC has terminated with the execution of the referenced operation, and has sent out a response. Tags: atp.EnumerationLiteralIndex=3

Table 5.8: TDEventOperationTypeEnum

[TPS_TIMEX_00085]{DRAFT} **TDEventModeDeclaration** specifies events observable at mode ports. [The element `TDEventModeDeclaration` is used to specify events, namely initiation and propagation of mode changes, observable at required and provided mode ports.] (*RS_TIMEX_00001*)

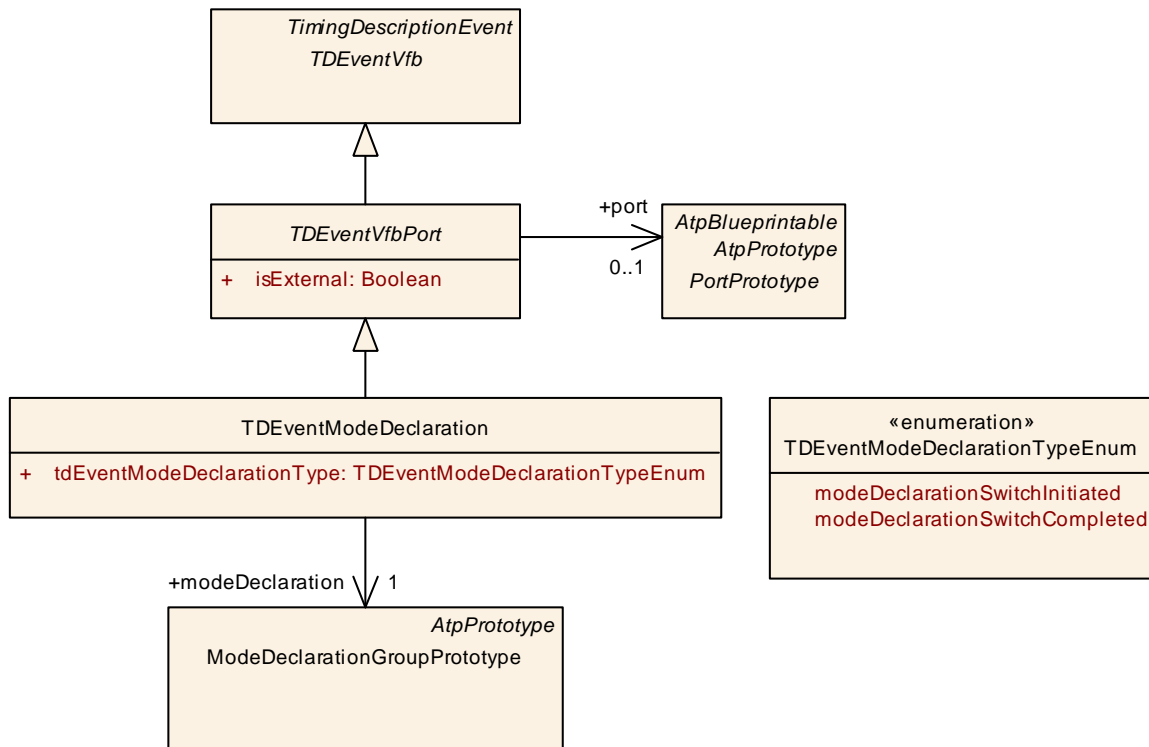

Figure 5.5: Mode Declaration

Class	TDEventModeDeclaration
Package	M2::AUTOSARTemplates::CommonStructure::Timing::TimingDescription::TimingDescriptionEvents::TDEventVfb::ModeDeclaration
Note	This is used to describe timing events related to mode switch communication at VFB level.





Class	TDEventModeDeclaration			
Base	<i>ARObject, Identifiable, MultilanguageReferrable, Referrable, TDEventVfb, TDEventVfbPort, TimingDescription, TimingDescriptionEvent</i>			
Attribute	Type	Mult.	Kind	Note
entryModeDeclaration	ModeDeclaration	0..1	ref	Optional parameter which refines the scope of the TDEventModeDeclaration. If the parameter is set, the event occurs only if the mode declaration group prototype instance shall enter into the referenced ModeDeclaration.
exitModeDeclaration	ModeDeclaration	0..1	ref	Optional parameter which refines the scope of the TDEventModeDeclaration. If the parameter is set, the event occurs only if the mode declaration group prototype instance shall exit from the referenced ModeDeclaration.
modeDeclaration	ModeDeclarationGroupPrototype	1	ref	The referenced mode declaration group prototype.
tdEventModeDeclarationType	TDEventModeDeclarationTypeEnum	1	attr	The specific type of this timing event.

Table 5.9: TDEventModeDeclaration

Enumeration	TDEventModeDeclarationTypeEnum
Package	M2::AUTOSARTemplates::CommonStructure::Timing::TimingDescription::TimingDescriptionEvents::TDEventVfb::ModeDeclaration
Note	This is used to describe the specific event type of a TDEventModeDeclaration
Literal	Description
modeDeclarationSwitchCompleted	A point in time where the switch to the associated ModeDeclarationGroupPrototype has been completed. Tags: atp.EnumerationLiteralIndex=0
modeDeclarationSwitchInitiated	A point in time where the switch to the associated ModeDeclarationGroupPrototype has been initiated. Tags: atp.EnumerationLiteralIndex=1

Table 5.10: TDEventModeDeclarationTypeEnum

[TPS_TIMEX_00090]{DRAFT} **TDEventTrigger** specifies events observable at trigger ports [The element [TDEventTrigger](#) is used to specify events, namely the activation and release of triggers, observable at required and provided trigger ports.] ([RS_TIMEX_00001](#))

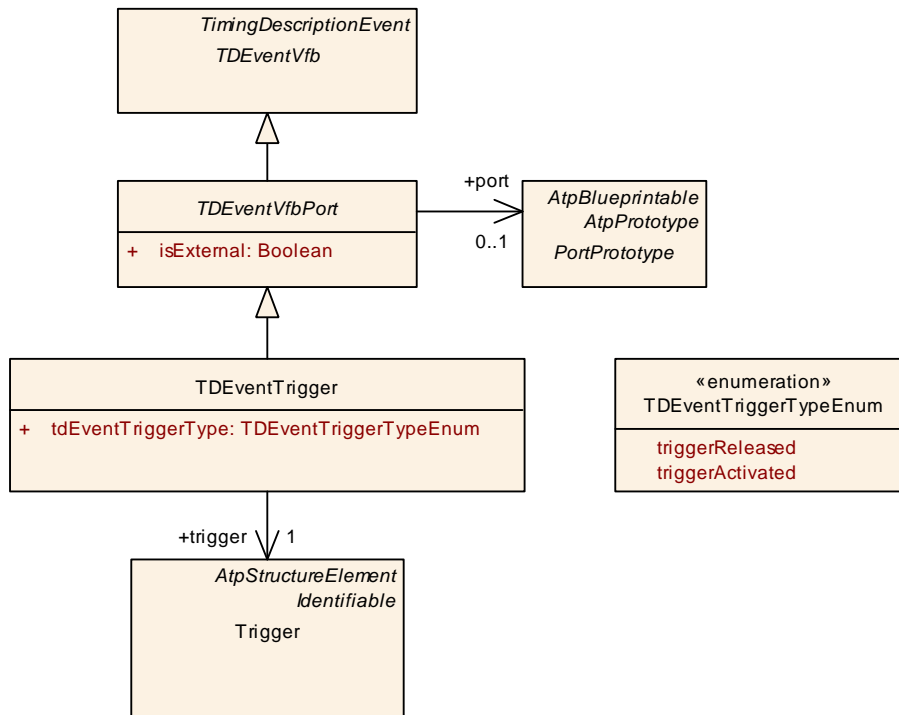

Figure 5.6: Trigger

Class	TEventTrigger			
Package	M2::AUTOSARTemplates::CommonStructure::Timing::TimingDescription::TimingDescriptionEvents::TEventVfb::Trigger			
Note	This is used to describe timing events related to triggers at VFB level.			
Base	ARObject, Identifiable, MultilanguageReferrable, Referrable, TEventVfb, TEventVfbPort, TimingDescription, TimingDescriptionEvent			
Attribute	Type	Mult.	Kind	Note
tdEventTriggerType	TEventTriggerTypeEnum	1	attr	The specific type of this timing event.
trigger	Trigger	1	ref	The trigger which is provided (released) or required (activate) in the given context.

Table 5.11: TEventTrigger

Enumeration	TEventTriggerTypeEnum
Package	M2::AUTOSARTemplates::CommonStructure::Timing::TimingDescription::TimingDescriptionEvents::TEventVfb::Trigger
Note	This is used to describe the specific event type of a TEventTrigger.
Literal	Description
triggerActivated	A point in time where the referenced trigger has been successfully released and is activating runnable entities of the receiving SW-C. Tags: atp.EnumerationLiteralIndex=0
triggerReleased	A point in time where the referenced trigger has been successfully released by the emitting SW-C. Tags: atp.EnumerationLiteralIndex=1

Table 5.12: TEventTriggerTypeEnum

5.2 Timing Events related to Service Timing

[TPS_TIMEX_00058]{DRAFT} **Purpose of TDEventServiceInstance** [The element *TDEventServiceInstance* and its specializations are used to describe the occurrences of an event which are observed at a specific location in the Service view.] (*RS_TIMEX_00001*, *RS_TIMEX_00024*)

Events related to the adaptive service can be used during the specification of:

- [VfbTiming 3.2](#)
- [SystemTiming 3.3](#)
- [ServiceTiming 3.6](#)

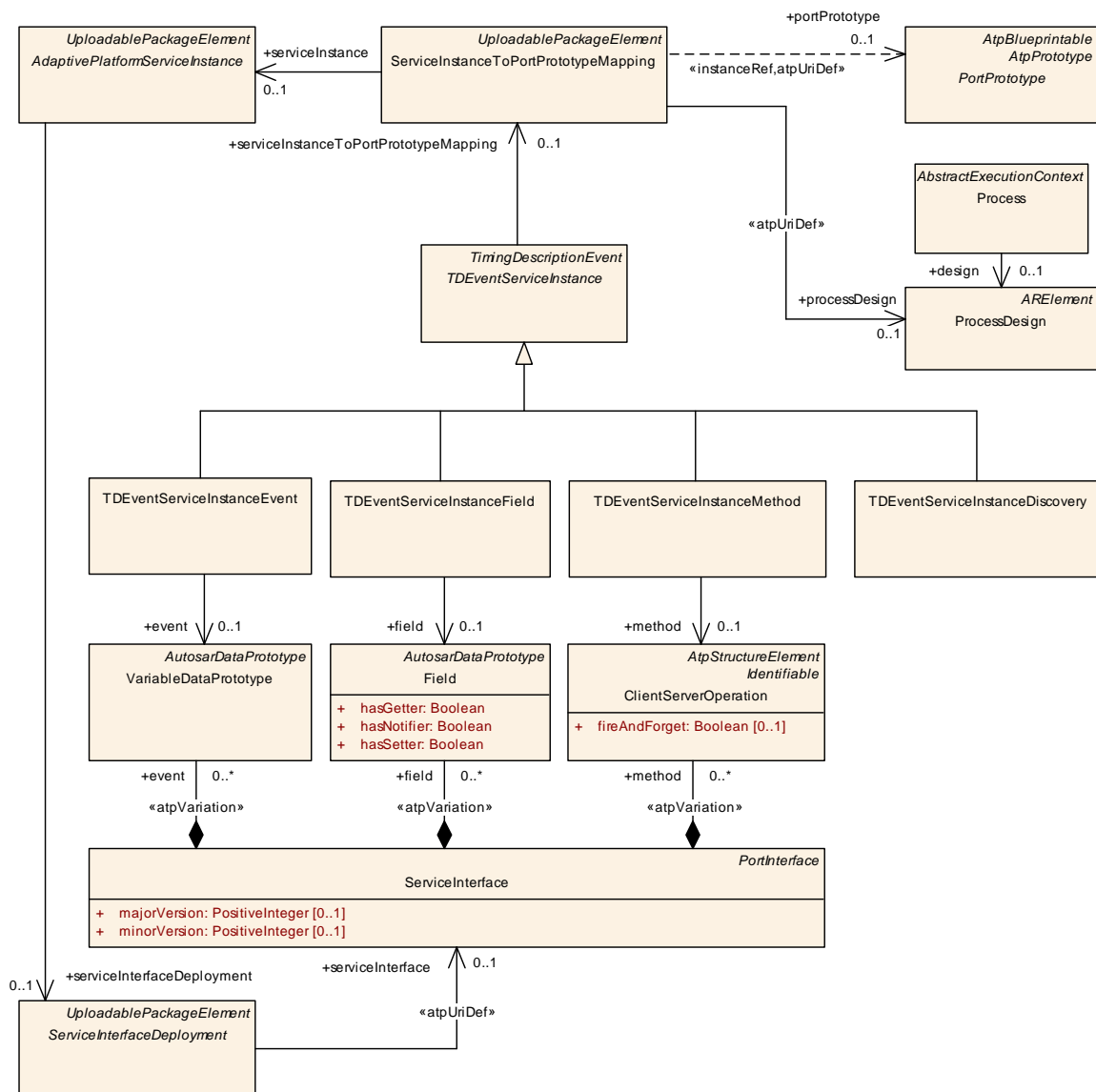

Figure 5.7: Adaptive Service events

Class	TDEventServiceInstance (abstract)			
Package	M2::AUTOSARTemplates::CommonStructure::Timing::TimingAdaptivePlatform::Timing Description::TDEventServiceInstance			
Note	This is the abstract parent class to describe specific timing description event types for service-oriented communication. Tags: atp.Status=draft			
Base	ARObject, Identifiable, MultilanguageReferrable, Referrable, TimingDescription, TimingDescriptionEvent			
Subclasses	TDEventServiceInstanceDiscovery, TDEventServiceInstanceEvent, TDEventServiceInstanceField, TDEventServiceInstanceMethod			
Attribute	Type	Mult.	Kind	Note
serviceInstanceToPortPrototypeMapping	ServiceInstanceToPortPrototypeMapping	0..1	ref	The service and the port this service is provided. Tags: atp.Status=draft

Table 5.13: TDEventServiceInstance

[TPS_TIMEX_00059]{DRAFT} **Purpose of TDEventServiceInstanceEvent**
 [The element TDEventServiceInstanceEvent is used to describe the occurrences of an event which are observed at a specific location in the Service view.]
 (RS_TIMEX_00001, RS_TIMEX_00024)

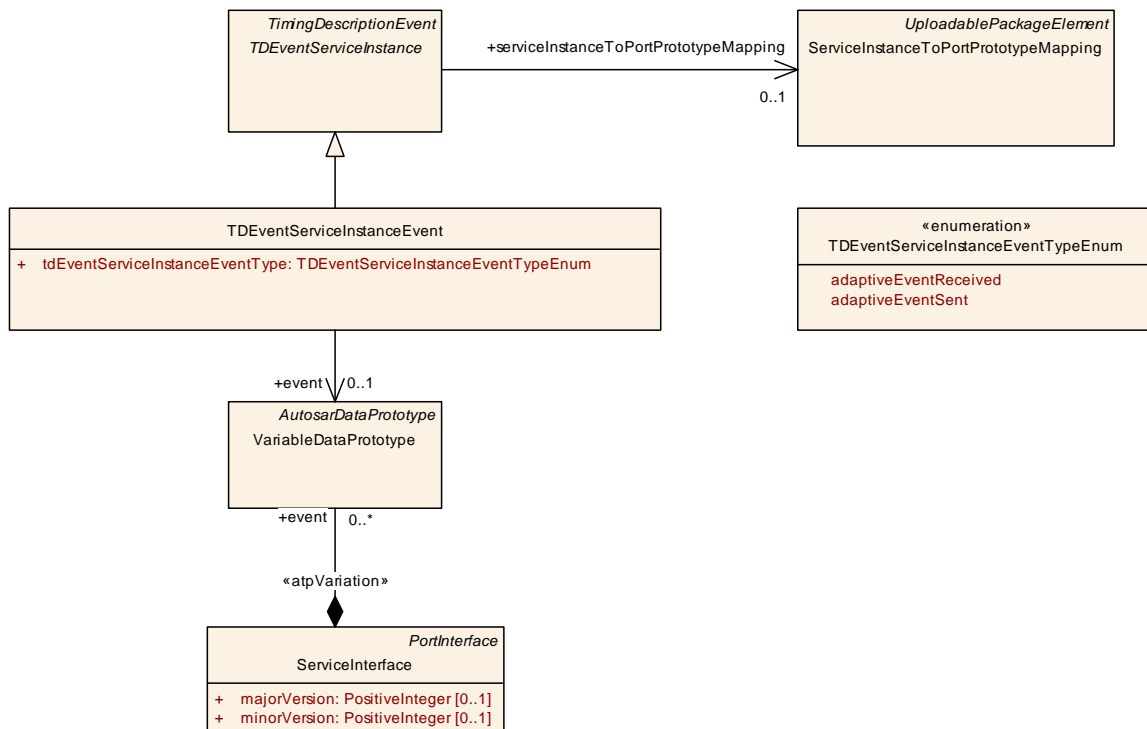

Figure 5.8: Adaptive Service Event

Class	TDEventServiceInstanceEvent
Package	M2::AUTOSARTemplates::CommonStructure::Timing::TimingAdaptivePlatform::Timing Description::TDEventServiceInstance::TDEventServiceInstanceEvent





Class	TDEventServiceInstanceEvent			
Note	This is used to describe timing description events related to events of a service. Tags: atp.Status=draft			
Base	<i>ARObject, Identifiable, MultilanguageReferrable, Referrable, TDEventServiceInstance, TimingDescription, TimingDescriptionEvent</i>			
Attribute	Type	Mult.	Kind	Note
event	VariableDataPrototype	0..1	ref	The event provided by the service. Tags: atp.Status=draft
tdEventServiceInstanceEvent Type	TDEventServiceInstanceEventTypeEnum	1	attr	The specific type of this timing event. Tags: atp.Status=draft

Table 5.14: TDEventServiceInstanceEvent

Enumeration	TDEventServiceInstanceEventTypeEnum
Package	M2::AUTOSARTemplates::CommonStructure::Timing::TimingAdaptivePlatform::TimingDescription::TDEventServiceInstance::TDEventServiceInstanceEvent
Note	This is used to describe the specific event type of a TDEventServiceInstanceEvent. Tags: atp.Status=draft
Literal	Description
adaptiveEventReceived	A point in time where an event required by a service subscriber is received through the service port of the service subscriber. Tags: atp.EnumerationLiteralIndex=1 atp.Status=draft
adaptiveEventSent	A point in time where an event provided by a service is sent through the service port of the service provider. Tags: atp.EnumerationLiteralIndex=0 atp.Status=draft

Table 5.15: TDEventServiceInstanceEventTypeEnum

[TPS_TIMEX_00060]{DRAFT} Purpose of [TDEventServiceInstanceField](#)
 [The element [TDEventServiceInstanceField](#) is used to describe the occurrences of an event which are observed at a specific location in the Service view.]
 ([RS_TIMEX_00001](#), [RS_TIMEX_00024](#))

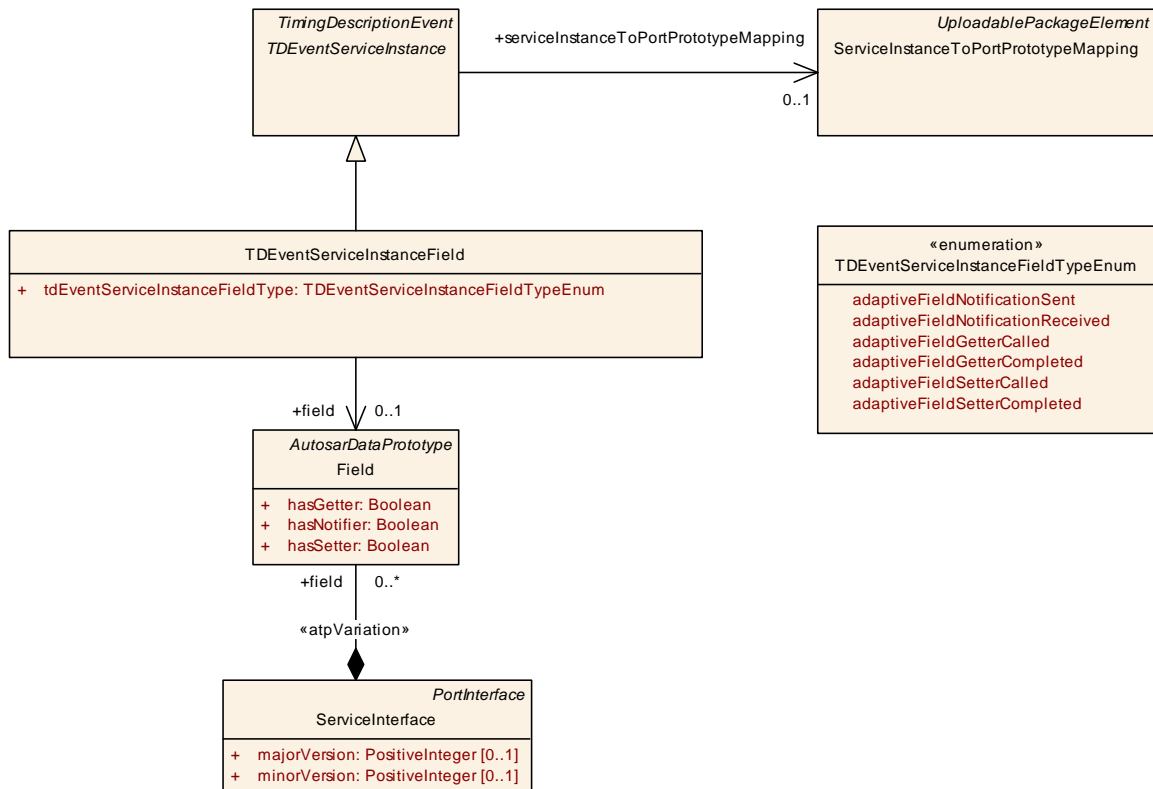

Figure 5.9: Adaptive Service Field

Class	TEventServiceInstanceField			
Package	M2::AUTOSARTemplates::CommonStructure::Timing::TimingAdaptivePlatform::TimingDescription::TEventServiceInstance::TEventServiceInstanceField			
Note	This is used to describe timing description events related to fields of a service. Tags: atp.Status=draft			
Base	ARObject, Identifiable, MultilanguageReferrable, Referrable, TEventServiceInstance, TimingDescription, TimingDescriptionEvent			
Attribute	Type	Mult.	Kind	Note
field	Field	0..1	ref	The field provided by the service. Tags: atp.Status=draft
tdEventServiceInstanceFieldType	TEventServiceInstanceFieldTypeEnum	1	attr	The specific type of this timing event. Tags: atp.Status=draft

Table 5.16: TEventServiceInstanceField

Enumeration	TEventServiceInstanceFieldTypeEnum
Package	M2::AUTOSARTemplates::CommonStructure::Timing::TimingAdaptivePlatform::TimingDescription::TEventServiceInstance::TEventServiceInstanceField
Note	This is used to describe the specific event type of a TEventServiceInstanceField. Tags: atp.Status=draft
Literal	Description





Enumeration	TDEventServiceInstanceFieldTypeEnum
adaptiveFieldGetter Called	A point in time where a field getter of a service is called by a service subscriber through the service port of the service subscriber. Tags: atp.EnumerationLiteralIndex=2 atp.Status=draft
adaptiveFieldGetter Completed	A point in time where a field getter of a service is completed and the result of the field getter is received through the service subscriber's service port. Tags: atp.EnumerationLiteralIndex=3 atp.Status=draft
adaptiveField Notification Received	A point in time where a field notification required by a service subscriber is received through the service port of the service subscriber. Tags: atp.EnumerationLiteralIndex=1 atp.Status=draft
adaptiveField NotificationSent	A point in time where a field notification provided by a service is sent through the service port of the service provider. Tags: atp.EnumerationLiteralIndex=0 atp.Status=draft
adaptiveFieldSetter Called	A point in time where a field setter of a service is called by a service subscriber through the service port of the service subscriber. Tags: atp.EnumerationLiteralIndex=4 atp.Status=draft
adaptiveFieldSetter Completed	A point in time where a field setter of a service is completed and the result of the field setter is received through the service subscriber's service port. Tags: atp.EnumerationLiteralIndex=5 atp.Status=draft

Table 5.17: TDEventServiceInstanceFieldTypeEnum

[TPS_TIMEX_00061]{DRAFT} **Purpose of [TDEventServiceInstanceMethod](#)**
[The element [TDEventServiceInstanceMethod](#) is used to describe the occurrences of an event which are observed at a specific location in the Service view.]
([RS_TIMEX_00001](#), [RS_TIMEX_00024](#))

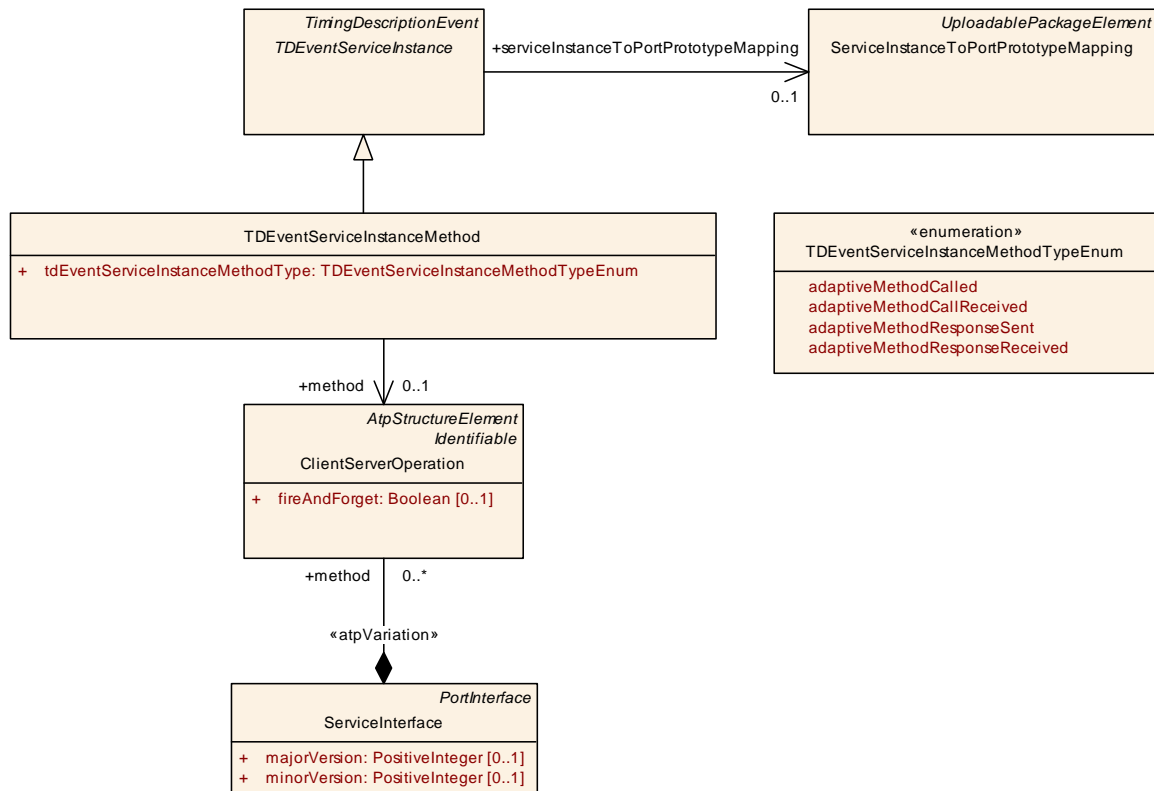

Figure 5.10: Adaptive Service Method

Class	TDEventServiceInstanceMethod			
Package	M2::AUTOSARTemplates::CommonStructure::Timing::TimingAdaptivePlatform::TimingDescription::TDEventServiceInstance::TDEventServiceInstanceMethod			
Note	This is used to describe timing description events related to methods of a service. Tags: atp.Status=draft			
Base	ARObject, Identifiable, MultilanguageReferrable, Referrable, TDEventServiceInstance, TimingDescription, TimingDescriptionEvent			
Attribute	Type	Mult.	Kind	Note
method	ClientServerOperation	0..1	ref	The method provided by the service. Tags: atp.Status=draft
tdEventServiceInstanceMethodType	TDEventServiceInstanceMethodTypeEnum	1	attr	The specific type of this timing event. Tags: atp.Status=draft

Table 5.18: TDEventServiceInstanceMethod

Enumeration	TDEventServiceInstanceMethodTypeEnum
Package	M2::AUTOSARTemplates::CommonStructure::Timing::TimingAdaptivePlatform::TimingDescription::TDEventServiceInstance::TDEventServiceInstanceMethod
Note	This is used to describe the specific event type of a TDEventServiceInstanceMethod. Tags: atp.Status=draft
Literal	Description





Enumeration	TDEventServiceInstanceMethodTypeEnum
adaptiveMethodCalled	A point in time where a method of a service is called through the service subscriber's service port. Tags: atp.EnumerationLiteralIndex=0 atp.Status=draft
adaptiveMethodCallReceived	A point in time where a method call of a service is received through the service provider's service port. Tags: atp.EnumerationLiteralIndex=1 atp.Status=draft
adaptiveMethodResponseReceived	A point in time where a response of a method call of a service is received through the service subscribers's service port. Tags: atp.EnumerationLiteralIndex=3 atp.Status=draft
adaptiveMethodResponseSent	A point in time where a response of a method call of a service is sent through the service provider's service port. Tags: atp.EnumerationLiteralIndex=2 atp.Status=draft

Table 5.19: TDEventServiceInstanceMethodTypeEnum

[TPS_TIMEX_00062]{DRAFT} **Purpose of TDEventServiceInstanceDiscovery** [The element `TDEventServiceInstanceDiscovery` is used to describe the occurrences of an event which are observed at a specific location in the Service view.] (*RS_TIMEX_00001*, *RS_TIMEX_00024*)

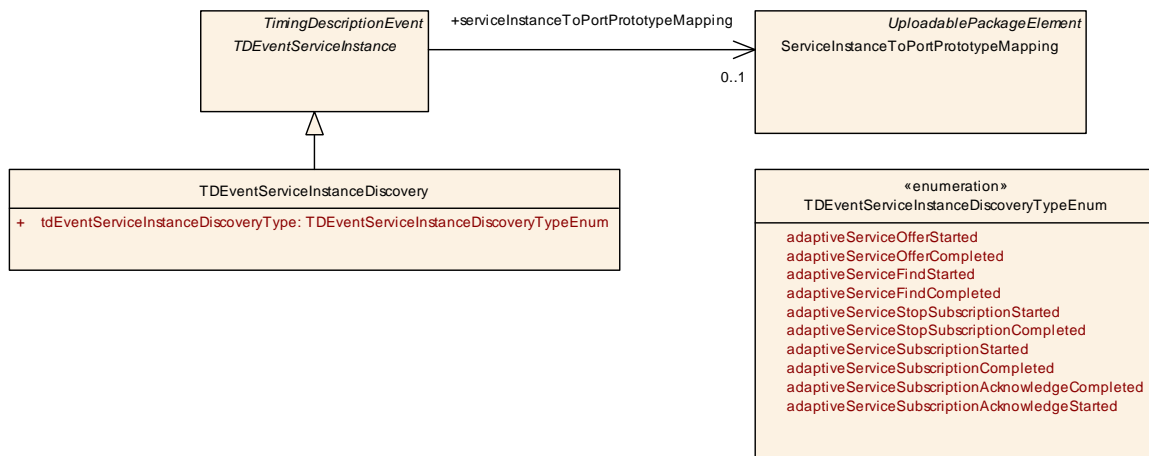

Figure 5.11: Adaptive Service Discovery

Class	TDEventServiceInstanceDiscovery
Package	M2::AUTOSARTemplates::CommonStructure::Timing::TimingAdaptivePlatform::TimingDescription::TDEventServiceInstance::TDEventServiceInstanceService
Note	This is used to describe timing description events related to different phases of service discovery. Tags: atp.Status=draft





Class	TDEventServiceInstanceDiscovery			
Base	<i>ARObject, Identifiable, MultilanguageReferrable, Referrable, TDEventServiceInstance, TimingDescription, TimingDescriptionEvent</i>			
Attribute	Type	Mult.	Kind	Note
tdEventServiceInstanceDiscoveryType	TDEventServiceInstanceDiscoveryType Enum	1	attr	The specific type of this timing event. Tags: atp.Status=draft

Table 5.20: TDEventServiceInstanceDiscovery

Enumeration	TDEventServiceInstanceDiscoveryTypeEnum
Package	M2::AUTOSARTemplates::CommonStructure::Timing::TimingAdaptivePlatform::TimingDescription::TDEventServiceInstance::TDEventServiceInstanceService
Note	This is used to describe the specific event type of a TDEventServiceInstanceDiscovery. Tags: atp.Status=draft
Literal	Description
adaptiveServiceFindCompleted	A point in time where a service subscriber completes to find a needed service. Tags: atp.EnumerationLiteralIndex=1 atp.Status=draft
adaptiveServiceFindStarted	A point in time where a service subscriber starts to find a needed service. Tags: atp.EnumerationLiteralIndex=0 atp.Status=draft
adaptiveServiceOfferCompleted	A point in time where a service provider completes to offer a needed service. Tags: atp.EnumerationLiteralIndex=3 atp.Status=draft
adaptiveServiceOfferStarted	A point in time where a service provider starts to offer a needed service. Tags: atp.EnumerationLiteralIndex=2 atp.Status=draft
adaptiveServiceStopSubscriptionCompleted	A point in time where a service subscriber completes to stop subscribing to a needed service. Tags: atp.EnumerationLiteralIndex=9 atp.Status=draft
adaptiveServiceStopSubscriptionStarted	A point in time where a service subscriber starts to stop subscribing to a needed service. Tags: atp.EnumerationLiteralIndex=8 atp.Status=draft
adaptiveServiceSubscriptionAcknowledgeCompleted	A point in time where a service provider completes to acknowledge subscription to a needed service. Tags: atp.EnumerationLiteralIndex=7 atp.Status=draft
adaptiveServiceSubscriptionAcknowledgeStarted	A point in time where a service provider starts to acknowledge subscription to a needed service. Tags: atp.EnumerationLiteralIndex=6 atp.Status=draft
adaptiveServiceSubscriptionCompleted	A point in time where a service subscriber completes to subscribe to a needed service. Tags: atp.EnumerationLiteralIndex=5 atp.Status=draft





Enumeration	TDEventServiceInstanceDiscoveryTypeEnum
adaptiveServiceSubscriptionStarted	A point in time where a service subscriber starts to subscribe to a needed service. Tags: atp.EnumerationLiteralIndex=4 atp.Status=draft

Table 5.21: TDEventServiceInstanceDiscoveryTypeEnum

5.3 Complex Timing Event

[TPS_TIMEX_00086]{DRAFT} **Purpose of TDEventComplex** [The element `TDEventComplex` is used to specify relationships between occurrences of events.] ([RS_TIMEX_00001](#))

Complex timing events can be used during the specification of:

- [VfbTiming 3.2](#)
- [SystemTiming 3.3](#)

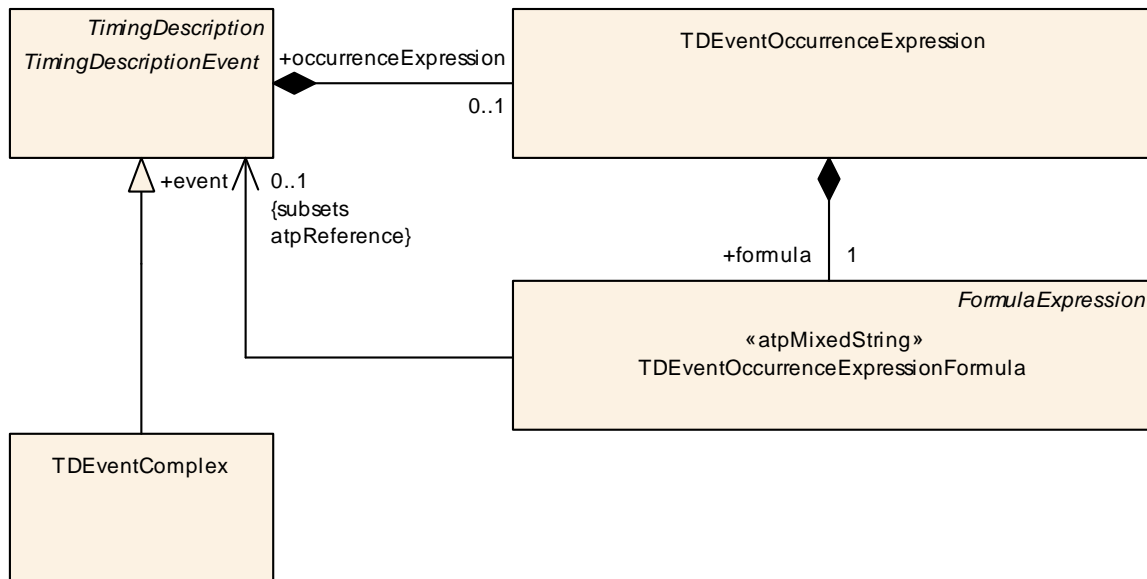

Figure 5.12: Complex timing event

Class	TDEventComplex
Package	M2::AUTOSARTemplates::CommonStructure::Timing::TimingDescription::TimingDescription Events::TDEventComplex
Note	This is used to describe complex timing events. The context of a complex timing event either is described informally, e.g. using the documentation block, or is described formally by the associated TDEventOccurrenceExpression.
Base	ARObject, Identifiable, MultilanguageReferrable, Referrable, TimingDescription , TimingDescriptionEvent





<i>Class</i>	TDEventComplex			
<i>Attribute</i>	<i>Type</i>	<i>Mult.</i>	<i>Kind</i>	<i>Note</i>
–	–	–	–	–

Table 5.22: TDEventComplex

A complex timing event is a special observable event. In comparison to the "atomic" events described above a complex event does not contain information about the context it references, like [VariableDataPrototype](#) in [TDEventVariableDataPrototype](#). Instead, a complex event uses the occurrence expression to specify the context with regard to occurrences of [TimingDescriptionEvents](#) as describe in the following section.

5.4 Occurrence Expression Language for Timing Events

The [TimingDescriptionEvents](#) mentioned in the previous sections allow to specify observable events with a well-defined context. However, sometimes the context information of the events is not sufficient, because additional conditions, like a value filter or additional stimuli, influence the occurrence. Thus, the occurrence expression provides means to overcome the limitations of atomic events.

The occurrence expression provides the ability to refine the context specification of a timing event for the following cases:

Content Filter filters occurrences of an atomic event based on the *value* of exchanged data or operation arguments.

Complex Event combines any number of atomic and complex event to specify a new timing event.

5.4.1 Specifying an Occurrence Expression

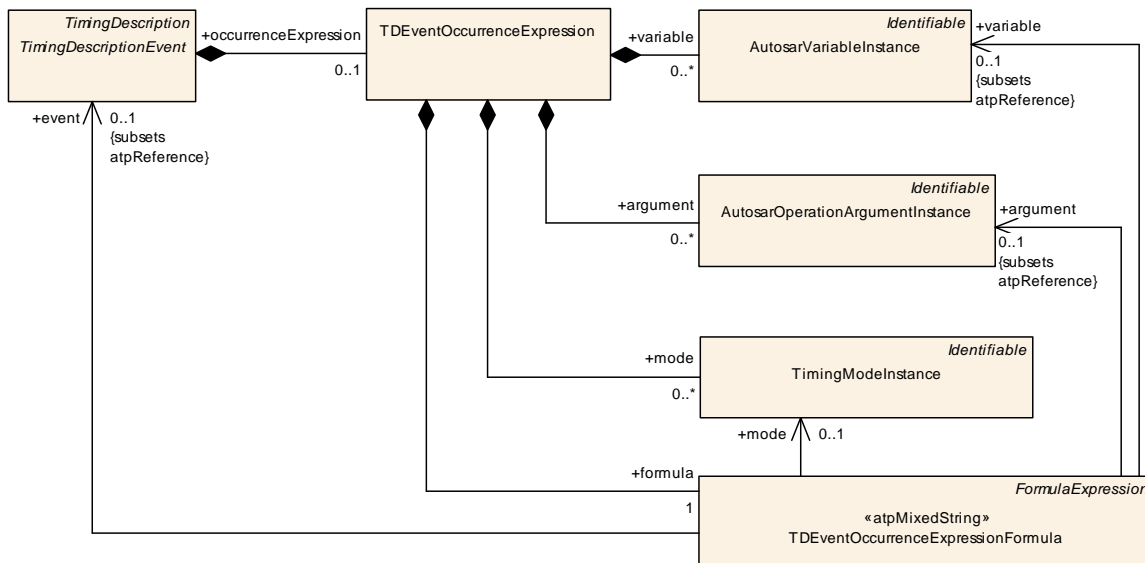

Figure 5.13: The occurrence expression

As shown in Figure 5.13, each `TimingDescriptionEvent` aggregates a `TDEventOccurrenceExpression` as optional parameter. A `TDEventOccurrenceExpression` is a container for all information required to formulate the expression. The expression itself is defined via `TDEventOccurrenceExpressionFormula` which is derived from `FormulaExpression` (see Generic Structure Template [5]). The `TDEventOccurrenceExpressionFormula` uses the capabilities of the `FormulaExpression` and adds the following functions to the expression language:

- The function `TIMEX_value`, which requires as operand either a reference to an `AutosarVariableInstance` or a reference to an `AutosarOperationArgumentInstance` whose value shall be evaluated. The return type of this function is `Numerical` (see constraint [constr_4591]).
- The function `TIMEX_occurs`, which requires as operand a reference to the `TimingDescriptionEvent` whose occurrence shall be evaluated. The return type of this function is `Boolean`. It returns `TRUE` if the referenced timing event occurs at the point in time the expression is evaluated.
- The function `TIMEX_hasOccurred`, which requires as operand a reference to the `TimingDescriptionEvent` whose occurrence shall be evaluated. The return type of this function is `Boolean`. It returns `TRUE` if the referenced timing event has occurred *at least once* before or at the same point in time the expression is evaluated.
- The function `TIMEX_timeSinceLastOccurrence`, which requires as operand a reference to the `TimingDescriptionEvent` whose occurrence shall be evaluated. The return type of this function is `Float` and the unit is seconds. It returns the time difference between the point in time of the last occurrence of the referenced event and the point in time the expression is evaluated.

- The function *TIMEX_angleSinceLastOccurrence*, which requires as operand a reference to the *TimingDescriptionEvent* whose occurrence shall be evaluated. The return type of this function is *Float* and the unit is degree. It returns the angle of the crank shaft between the point in time of the last occurrence of the referenced event and the point in time the expression is evaluated.
- The function *TIMEX_modeActive* queries the *TimingModeInstance* specified as argument. The return type of this function is *Boolean*. It returns TRUE if the specified mode declaration is *active* at the point in time the expression is evaluated, otherwise it returns FALSE.

All operands required by the functions are references to model elements. Thus, *TDEventOccurrenceExpressionFormula* requires references to the respective elements of type *TimingDescriptionEvent*, *AutosarVariableInstance* and *AutosarOperationArgumentInstance*. Due to the *atpMixedString* nature of the *TDEventOccurrenceExpressionFormula* several references can be used within the occurrence expression.

[constr_4569]{DRAFT} Restricted usage of functions [The functions *TIMEX_occurs*, *TIMEX_hasOccurred*, *TIMEX_timeSinceLastOccurrence*, *TIMEX_angleSinceLastOccurrence*, and *TIMEX_modeActive* can only be used for occurrence expressions, which are applied to events of type *TDEventComplex*.]()

[constr_4570]{DRAFT} Application rule for the occurrence expression in *TDEventComplex* [The occurrence expression shall be specified such that it describes an *event* rather than a state. As a consequence the occurrence expression shall ensure that a complex timing event *could* only occur at the occurrence time of one of the referenced *TimingDescriptionEvents*.]()

[constr_4571]{DRAFT} Use references only as function operands [The references to model elements (e.g. the *timing event* reference targeting *TimingDescriptionEvent*) do have specific semantics. The usage of these references within the expression is *only* allowed as operand of the functions mentioned above.]()

[constr_4591]{DRAFT} Use only Numericals in *TDEventOccurrenceExpression* [The target data prototype of the instance references of *variable* and *argument* shall be *Numerical*.]()

The example given below shows how to combine the functions mentioned above. The occurrence expression for a complex event called *EC* shall be described. Figure 5.14 sketches the AUTOSAR software component model of this example.

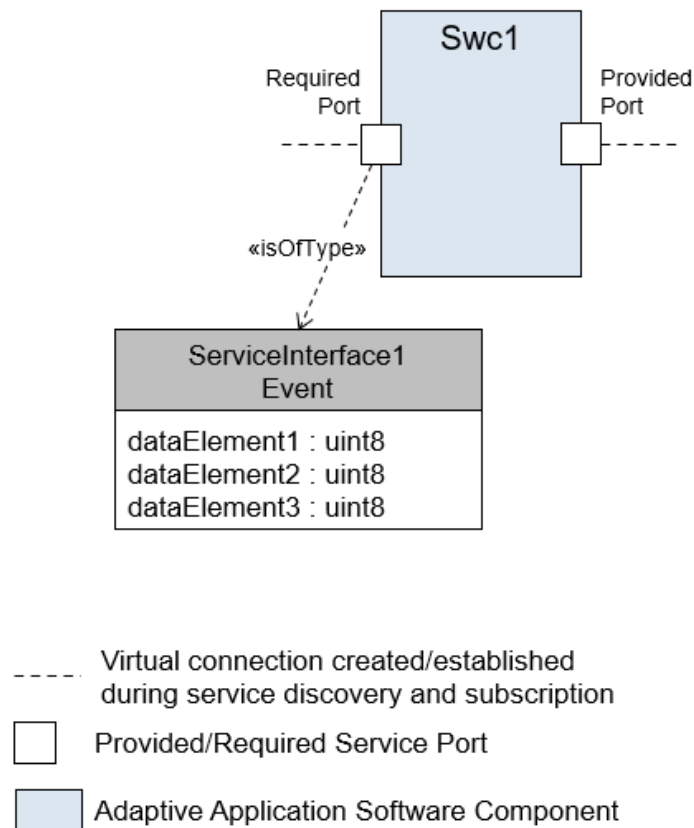

Figure 5.14: The software architecture used by the Occurrence Expression Example

The complex event *EC* occurs when the following conditions are fulfilled:

Condition1 Either atomic timing event *E1* or *E2* shall occur. In this example, *E1* and *E2* are atomic timing events which occur when the *VariableDataPrototype* *DE1* and *DE2* are received on *PortPrototype* called *Required Port* of the adaptive software software component called *Swc1*.

Condition2 *VariableDataPrototype* called *DE3* shall be greater than 3.

Condition3 The *VariableDataPrototypes* called *DE1* and *DE2* shall be received within a time interval of maximum 0.5 milliseconds.

The complex event *EC* would be described by the following occurrence expression:

```
//Condition 1
( TIMEX_occurs( /example/expression/E1 )
  || TIMEX_occurs( /example/expression/E2 ) )
//Condition 2
&& TIMEX_value( /example/expression/EC/DE3 ) > 3
//Condition 3
&& abs( TIMEX_timeSinceLastOccurrence( /example/expression/E1 ) -
  TIMEX_timeSinceLastOccurrence( /example/expression/E2 ) ) <= 0.0005
```

Due to the first condition the complex event *EC* can only occur when one of the atomic events *E1* or *E2* occurs at the point in time of evaluation. Thus, this expression satisfies the semantics constraint defined in [constr_4570].

The corresponding AUTOSAR XML file fragment for the complex event *EC* has the following appearance:

Listing 5.1: AUTOSAR XML representation of the occurrence expression for the complex event EC

```

<AR-PACKAGE>
  <SHORT-NAME>example</SHORT-NAME>
  <ELEMENTS>
    <VFB-TIMING>
      <SHORT-NAME>expression</SHORT-NAME>
      <TIMING-DESCRIPTIONS>
        <TD-EVENT-VARIABLE-DATA-PROTOTYPE>
          <SHORT-NAME>E1</SHORT-NAME>
          ...
        </TD-EVENT-VARIABLE-DATA-PROTOTYPE>
        <TD-EVENT-VARIABLE-DATA-PROTOTYPE>
          <SHORT-NAME>E2</SHORT-NAME>
          ...
        </TD-EVENT-VARIABLE-DATA-PROTOTYPE>
        <TD-EVENT-COMPLEX>
          <SHORT-NAME>EC</SHORT-NAME>
          <OCCURRENCE-EXPRESSION>
            <VARIABLES>
              <AUTOSAR-VARIABLE-INSTANCE>
                <SHORT-NAME>DE3</SHORT-NAME>
                <VARIABLE-INSTANCE-IREF>...</VARIABLE-INSTANCE-IREF>
              </AUTOSAR-VARIABLE-INSTANCE>
            </VARIABLES>
          <FORMULA>
            ((TIMEX_occurs(&lt;EVENT-REF DEST=&quot;TD-EVENT-VARIABLE-DATA-
              PROTOTYPE&quot;>/example/expression/E1&lt;/EVENT-REF>)
              || TIMEX_occurs(&lt;EVENT-REF DEST=&quot;TD-EVENT-VARIABLE-DATA-
              PROTOTYPE&quot;>/example/expression/E2&lt;/EVENT-REF>))
              &amp; &amp;
              TIMEX_value(&lt;VARIABLE-REF DEST=&quot;AUTOSAR-VARIABLE-INSTANCE
              &quot;>/example/expression/EC/DE3 &lt;/VARIABLE-REF>) > 3
              &amp; &amp;
              abs(TIMEX_timeSinceLastOccurrence(&lt;EVENT-REF DEST=&quot;TD-
              EVENT-VARIABLE-DATA-PROTOTYPE&quot;>
              /example/expression/E1&lt;/EVENT-REF>)
              - TIMEX_timeSinceLastOccurrence(&lt;EVENT-REF DEST=&quot;TD-EVENT
              -VARIABLE-DATA-PROTOTYPE&quot;>
              /example/expression/E1&lt;/EVENT-REF>))
              &lt;= 0.0005)
          </FORMULA>
        </OCCURRENCE-EXPRESSION>
      </TD-EVENT-COMPLEX>
    </TIMING-DESCRIPTIONS>
  <COMPONENT-REF DEST="COMPOSITION-SW-COMPONENT-TYPE"/>example/
  expression/SWC1</COMPONENT-REF>
</VFB-TIMING>

```

</ELEMENTS>
</AR-PACKAGE>

Class	TDEventOccurrenceExpression			
Package	M2::AUTOSARTemplates::CommonStructure::Timing::TimingDescription::TimingDescriptionEvents::TDEventOccurrenceExpression			
Note	This is used to specify a filter on the occurrences of TimingDescriptionEvents by means of a TDEventOccurrenceExpressionFormula. Filter criteria can be variable and argument values, i.e. the timing event only occurs for specific values, as well as the temporal characteristics of the occurrences of arbitrary timing events.			
Base	ARObject			
Attribute	Type	Mult.	Kind	Note
argument	AutosarOperationArgumentInstance	*	aggr	An occurrence expression can reference an arbitrary number of OperationArgumentPrototypes in its expression. This association aggregates instance references to OperationArgumentPrototypes which can be referenced in the expression.
formula	TDEventOccurrenceExpressionFormula	1	aggr	This is the expression formula which is used to describe the occurrence expression.
mode	TimingModelInstance	*	aggr	An occurrence expression can reference an arbitrary number of TimingModelInstances in its expression. This association aggregates instance references to ModeDeclaration which can be referenced in the expression.
variable	AutosarVariableInstance	*	aggr	An occurrence expression can reference an arbitrary number of VariableDataPrototypes in its expression. This association aggregates instance references to VariableDataPrototypes which can be referenced in the expression.

Table 5.23: TDEventOccurrenceExpression

Class	<<atpMixedString>> TDEventOccurrenceExpressionFormula			
Package	M2::AUTOSARTemplates::CommonStructure::Timing::TimingDescription::TimingDescriptionEvents::TDEventOccurrenceExpression			
Note	This is an extension of the FormulaExpression for the AUTOSAR Timing Extensions. A TDEventOccurrenceExpressionFormula provides the means to express the temporal characteristics of timing event occurrences in correlation with specific variable and argument values. The formal definition of the extended functions (ExtUnaryFunctions) is described in detail in the AUTOSAR Timing Extensions.			
Base	ARObject, FormulaExpression			
Attribute	Type	Mult.	Kind	Note
argument	AutosarOperationArgumentInstance	0..1	ref	This is one particular argument value used in the expression formula.
event	TimingDescriptionEvent	0..1	ref	This is one particular timing description event used in the expression formula.
mode	TimingModelInstance	0..1	ref	This is one particular mode used in the expression formula.
variable	AutosarVariableInstance	0..1	ref	This is one particular variable value used in the expression formula.

Table 5.24: TDEventOccurrenceExpressionFormula

Class	AutosarVariableInstance			
Package	M2::AUTOSARTemplates::CommonStructure::Timing::TimingDescription::TimingDescription Events::TDEventOccurrenceExpression::InstanceRefsUsage			
Note	<p>This class represents a reference to a variable instance within AUTOSAR. This way it is possible to reference a variable instance in the occurrence expression formula. The variable instance can target to one of the following variables:</p> <ul style="list-style-type: none"> • a variable provided via a PortPrototype as whole • an element inside of a composite variable provided via a PortPrototype 			
Base	<i>ARObject, Identifiable, MultilanguageReferrable, Referrable</i>			
Attribute	Type	Mult.	Kind	Note
variableInstance	DataPrototype	1	iref	<p>This is the reference to the instanceRef definition.</p> <p>InstanceRef implemented by:VariableInComponent InstanceRef</p>

Table 5.25: AutosarVariableInstance

Class	AutosarOperationArgumentInstance			
Package	M2::AUTOSARTemplates::CommonStructure::Timing::TimingDescription::TimingDescription Events::TDEventOccurrenceExpression::InstanceRefsUsage			
Note	<p>This class represents a reference to an argument instance. This way it is possible to reference an argument instance in the occurrence expression formula. The argument instance can target to one of the following arguments:</p> <ul style="list-style-type: none"> • a whole argument used in an operation of a PortPrototype with ClientServerInterface • an element inside of a composite argument used in an operation of a PortPrototype with ClientServerInterface 			
Base	<i>ARObject, Identifiable, MultilanguageReferrable, Referrable</i>			
Attribute	Type	Mult.	Kind	Note
operation Argument Instance	DataPrototype	1	iref	<p>This is the reference to the instanceRef definition.</p> <p>InstanceRef implemented by:OperationArgumentIn ComponentInstanceRef</p>

Table 5.26: AutosarOperationArgumentInstance

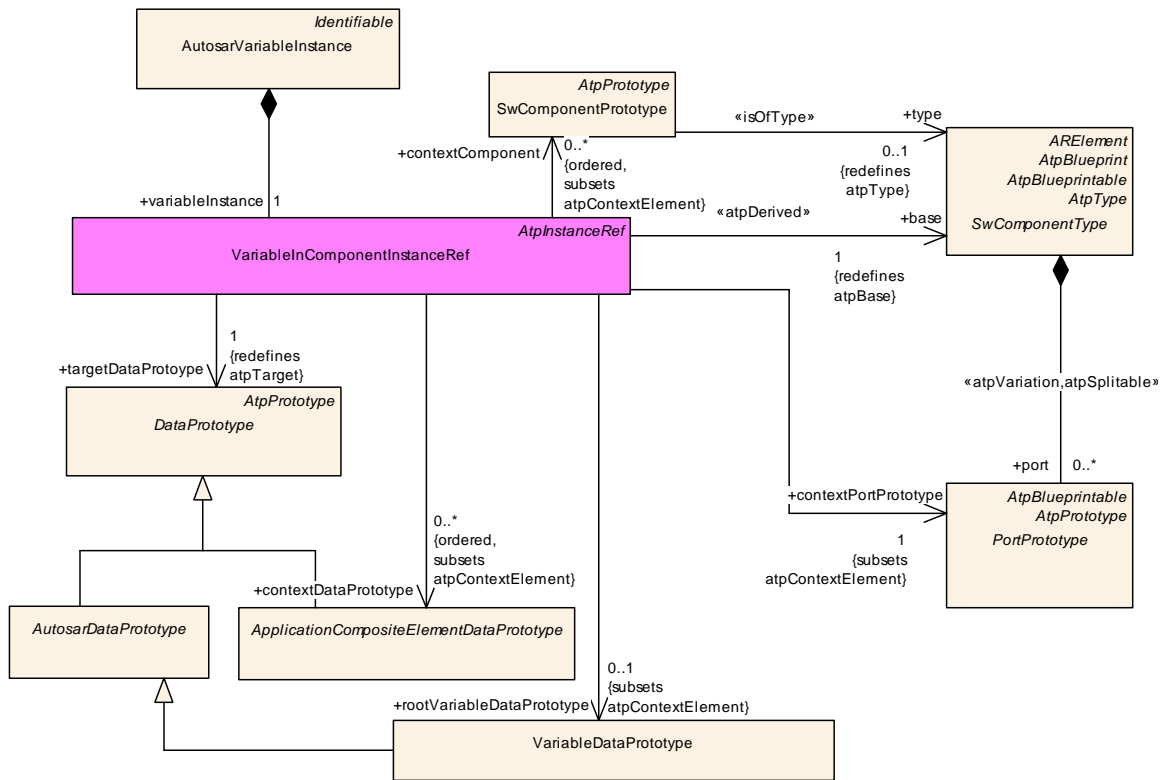

Figure 5.15: The required context information to reference a variable instance within AUTOSAR.

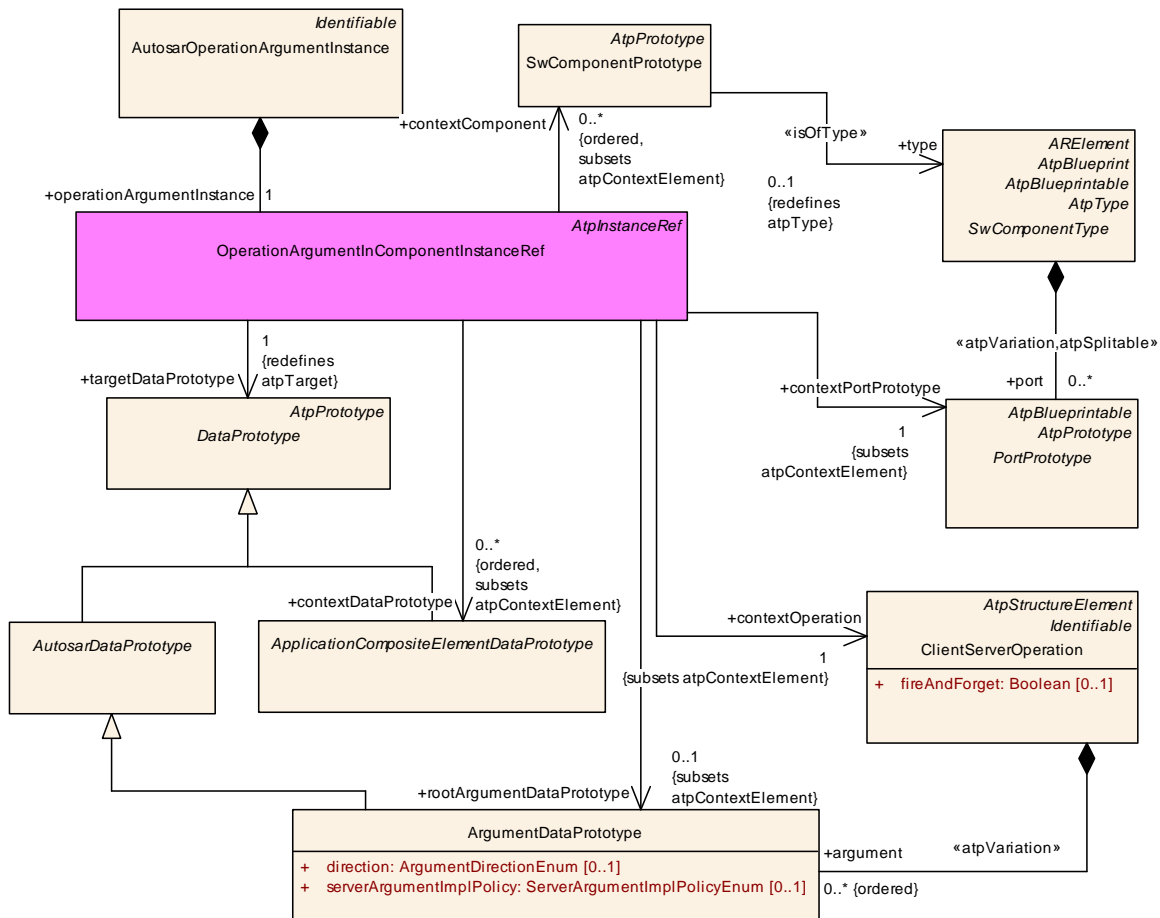

Figure 5.16: The required context information to reference an operation argument instance within AUTOSAR.

5.4.2 Occurrence Expression Language Syntax

The occurrence expression language is based on the syntax of the formula language defined in the Generic Structure Template [5]. It extends the language by additional functions and additional references to model elements. In the following, the implications of the extensions to the syntax are presented based on the grammar definition.

Note: The grammar defined for the formula language is not part of the listing below. It presents only the timing specific extensions of the formula language and the enhanced functions and references.

Listing 5.2: AUTOSAR Occurrence Expression Language

```
ExtUnaryFuncName : 'TIMEX_value' |
                  'TIMEX_occurs' |
                  'TIMEX_hasOccurred' |
                  'TIMEX_timeSinceLastOccurrence' |
                  'TIMEX_angleSinceLastOccurrence' |
                  'TIMEX_modeActive'
                  ;
```

5.4.3 Interpreting an Occurrence Expression

Based on the specification mechanism described in the previous sections it is possible to use the occurrence expression formula to refine the timing specification to the intended precision. This section describes how such an occurrence expression has to be interpreted. The duty of the interpreter is to determine the occurrences of the `TimingDescriptionEvent` for which the occurrence expression is defined. This is done in two ways, depending on whether the occurrence expression is used as a content filter or as a complex event.

5.4.3.1 Interpreting a Content Filter

In this case, the occurrence expression is defined for an atomic event. Only the unary timing function `TIMEX_value(<reference to argument or variable>)` is allowed to be used for the content filter. On each occurrence of the atomic event the interpreter checks whether the content filter defined by the expression is fulfilled. This is done by evaluating the function `TIMEX_value` based on its operand type:

AutosarVariableInstance the value of the referenced variable is evaluated at the point in time the atomic event occurs.

AutosarOperationArgumentInstance the value of the referenced argument is evaluated at the point in time the atomic event occurs.

[constr_4592]{DRAFT} Restricted usage of AutosarVariableInstance for Content Filter [If a content filter is defined for an atomic event then references to `AutosarVariableInstances` are only allowed if the atomic event is of type `TDEventVariableDataPrototype`. Only if such an atomic event occurs, the value of the variables can be evaluated. Thus, also the scope of the atomic event shall be the same as the `AutosarVariableInstance`, meaning that they shall point to the same `VariableDataPrototype`.]()

[constr_4572]{DRAFT} Restricted usage of AutosarOperationArgumentInstance for Content Filter [If a content filter is defined for an atomic event then references to `AutosarOperationArgumentInstances` are only allowed if the atomic event is of type `TDEventOperation`. Only if such an atomic event occurs, the value of the operation arguments can be evaluated. Thus, also the scope of the atomic event shall be the same as the `AutosarOperationArgumentInstance`, meaning that they shall point to the same `ClientServerOperation`. Finally, references to an `AutosarOperationArgumentInstance` with argument direction "out" are only allowed, if the atomic event of type `TDEventOperation` refers either to the point in time when the operation call response has been sent (TD-EVENT-OPERATION-TYPE=OPERATION-CALL-RESPONSE-SENT) or to the point in time when the operation call response has been received (TD-EVENT-OPERATION-TYPE=OPERATION-CALL-RESPONSE-RECEIVED).]()

5.4.3.2 Interpreting a Complex Event

In this case, the occurrence expression is defined for a complex event. All features of the occurrence expression language can be used for this expression type. At a specific point in time t , the interpreter evaluates the expression to determine if the complex event has occurred.

Considering the occurrence expression defined for the example given in Section 5.4.1, the interpreter "implements" a function $EC(t)$ which returns TRUE, if the complex event EC occurs at time t :

```
EC(t) =  
( TIMEX_occurs( t, /example/expression/E1 )  
  || TIMEX_occurs( t, /example/expression/E2 ) )  
&& TIMEX_value( t, /example/expression/EC/DE3 ) > 3  
&& abs( TIMEX_timeSinceLastOccurrence( t, /example/expression/E1 ) -  
        TIMEX_timeSinceLastOccurrence( t, /example/expression/E2 ) ) <= 0.0005
```

Since the expression satisfies [constr_4570], it shall only be evaluated at occurrence times of $E1$ or $E2$, because only then the complex event EC can occur and the expression can return TRUE.

As shown in the sketched trace in Figure 5.17 the timing description events called $E1$ and $E2$ occur at different times. On the left hand side of this figure the two events occur within a time interval of 0.0005 seconds. The point in time the given occurrence expression is evaluated is the point in time the event $E2$ occurs. The result of the occurrence expression at this point in time, $t_{evaluate}$ respectively t_{E2} , is TRUE. On the right hand side of this figure the two events do not occur within a time interval of 0.0005 seconds. The point in time the given occurrence expression is evaluated is the point in time the event $E1$ occurs. The result of the occurrence expression at this point in time, $t_{evaluate}$ respectively t_{E1} , is FALSE.

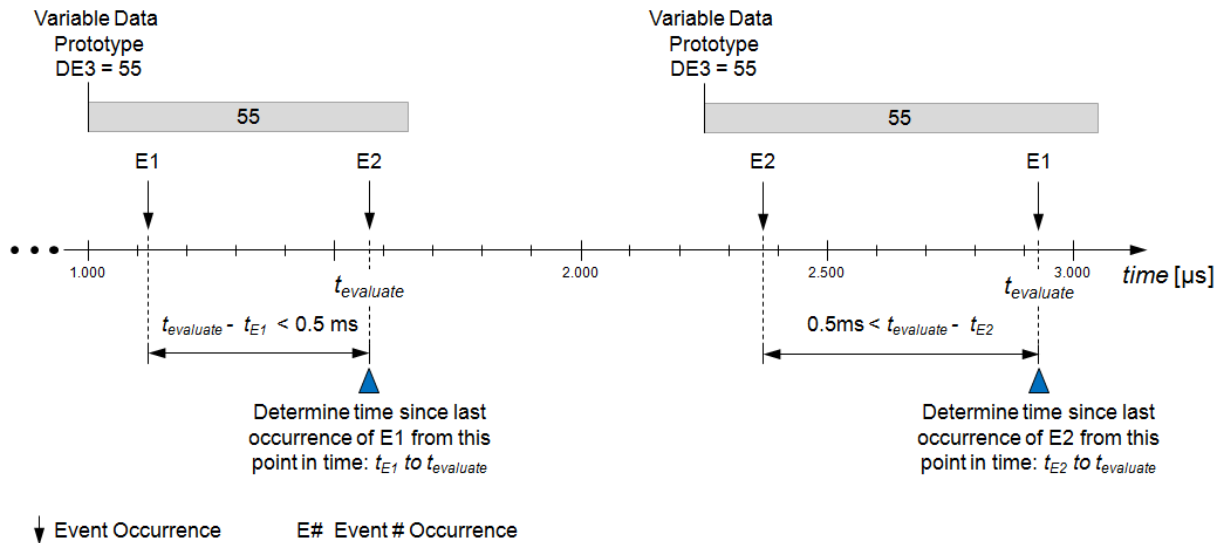

Figure 5.17: Trace showing various occurrences of the timing description events *E1* and *E2*, as well as the value of the variable *DE3*.

Based on the several functions provided by the occurrence expression language, the interpreter requires the following information from the system:

- the value of a referenced [AutosarOperationArgumentInstance](#) at time *t*.
- the value of a referenced [AutosarVariableInstance](#) at time *t*.
- the occurrences of a referenced [TimingDescriptionEvent](#) at time *t* and before.

There are different ways to gather the required information:

- Model analysis and simulation: In a deterministic system environment, occurrences of [TimingDescriptionEvents](#) can be determined offline, for example the point in time a frame will be transmitted in the static segment of a FlexRay network.
- Target trace: The required information can be gathered from a running system by recording the points in time a [TimingDescriptionEvent](#) has occurred.

If the interpreter has the required information as input, the different functions provided by the occurrence expression language can be interpreted as follows:

- `TIMEX_value(t, <reference to an AutosarVariableInstance>)` returns the variable value at time *t*.
- `TIMEX_value(t, <reference to an AutosarOperationArgumentInstance>)` returns the operation argument value at time *t*.
- `TIMEX_occurs(t, <reference to a TimingDescriptionEvent>)` returns TRUE (or 1) if the referenced event has occurred at time *t*, else it returns FALSE (or 0).

- `TIMEX_hasOccurred(t, <reference to a TimingDescriptionEvent>)` returns TRUE (or 1) if the referenced event has occurred *at least once* before or at time *t*.
- `TIMEX_timeSinceLastOccurrence(t, <reference to a TimingDescriptionEvent>)` returns the time difference between *t* and the point in time of the last occurrence of the referenced event. The unit of time is seconds.
- `TIMEX_angleSinceLastOccurrence(t, <reference to a TimingDescriptionEvent>)` returns the angle difference between *t* and the point in time of the last occurrence of the referenced event. The unit of angle is degree.
- `TIMEX_modeActive(t, <reference to a TimingModeInstance>)` returns TRUE (or 1) if the referenced mode is active at time *t*, else it returns FALSE (or 0).

6 Timing Description Event Chains

[TPS_TIMEX_00070]{DRAFT} **Purpose of [TimingDescriptionEventChain](#)**

[The element [TimingDescriptionEventChain](#) is used to specify a causal relationship between timing description events and their occurrences during the runtime of a system.]([RS_TIMEX_00001](#), [RS_TIMEX_00004](#), [RS_TIMEX_00005](#))

A timing event chain describes a causal order for a set of functionally dependent timing events. Each event chain defines at least the relationship between two differing events, its *stimulus* and *response* [[constr_4581](#)]. This means that if the stimulus event occurs then the response event occurs after or in other words the response event follows if and only if the stimulus event occurred before.

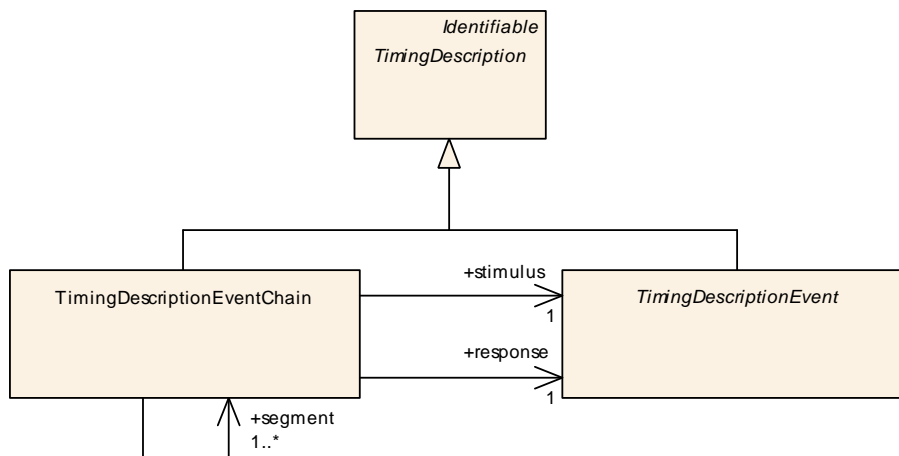

Figure 6.1: TimingDescriptionEventChain

Class	TimingDescriptionEventChain			
Package	M2::AUTOSARTemplates::CommonStructure::Timing::TimingDescription			
Note	An event chain describes the causal order for a set of functionally dependent timing events. Each event chain has a well defined stimulus and response, which describe its start and end point. Furthermore, it can be hierarchically decomposed into an arbitrary number of sub-chains, so called <i>event chain segments</i> .			
Base	ARObject, Identifiable, MultilanguageReferrable, Referrable, TimingDescription			
Attribute	Type	Mult.	Kind	Note
response	TimingDescriptionEvent	1	ref	The response event representing the point in time where the event chain is terminated. Tags: xml.sequenceOffset=20
segment	TimingDescriptionEventChain	1..*	ref	A composed event chain consists of an arbitrary number of sub-chains. Tags: xml.sequenceOffset=30
stimulus	TimingDescriptionEvent	1	ref	The stimulus event representing the point in time where the event chain is activated. Tags: xml.sequenceOffset=10

Table 6.1: TimingDescriptionEventChain

Thus, by means of an event chain, the correlation between a stimulation of a system and its corresponding response can be explicitly described, and used as a formalized definition of the scope for timing constraints. This is important, because timing constraints refer to a specific part of the overall system's timing and need clear validity semantics.

[constr_4581]{DRAFT} Specifying stimulus and response in [TimingDescriptionEventChain](#) [The references between [TimingDescriptionEventChain](#) and [TimingDescriptionEvent](#) playing the role *stimulus* and *response* shall not reference the same [TimingDescriptionEvent](#).]()

[constr_4582]{DRAFT} Specifying event chain segments [If a [TimingDescriptionEventChain](#) consists of further event chain segments then at least one sequence of event chain segments shall exist from the event chain's *stimulus* to the *response*.]()

[constr_4583]{DRAFT} Referencing no further event chain segments [If a [TimingDescriptionEventChain](#) is not subdivided in further event chain segments, then the reference playing the role of *segment* shall reference this [TimingDescriptionEventChain](#). In other words, an event chain without any event chain segment shall reference itself.]()

[constr_4584]{DRAFT} Specifying *stimulus* event and *response* event of first and last event chain segment [The *stimulus* event of the first event chain segment and the *response* event of the last event chain segment shall reference the *stimulus* and *response* of the parent event chain the event chain segments directly belong to.]()

6.1 Approach

The following subsections describe how to structure event chains for systems. Depending on the pre-conditions two different approaches can be distinguished: top-down (decomposition) and bottom-up (composition).

The decomposition and composition of event chains can be performed according to the software component hierarchy, but does not necessarily have to follow this hierarchy. The primary purpose is to increase respectively decrease granularity of the timing descriptions.

Note that event chains are used in all AUTOSAR timing views and any composition and decomposition of event chains can be done across various AUTOSAR timing views.

6.1.1 Decomposition

In a first step the time critical path in the system is identified. This means that a causal relationship between a stimulus event and response event is described by an event chain. For this event chain a timing constraint is specified describing the time budget. The second step is to decompose this event chain into event chain segments which implies that the given time budget gets split — decomposed —, too.

Since event chain segments are event chains as well, these event chain segments can be subject to further decomposition.

Figure 6.2 shows a time critical path between the event "requesting the brake pedal position" (*Stimulus*) and the event "making available the determined vehicle speed" (*Response*). This event chain (*EC*) is subject to a timing constraint, namely a `LatencyTimingConstraint`, and is budgeted accordingly. For example, the time budget for the event chain *EC* is constrained by a maximum latency of 2 ms.

In subsequent steps of the development and with deeper knowledge about the system's dynamics, this event chain and its time budget can be split across the system's components. This results in the event chain segments *EC1*, *EC2* and *EC3* and their appropriate time budgets. The sum of these time budgets shall not exceed the given time budget of 2 ms.

6.1.2 Composition

In the first step the system is build up based on available software components including timing descriptions. In the second step available event chains are connected with each other. This results in a sequence of event chains where the response event of one event chain plays the role of the stimulus event of the subsequent event chain. In the third step, a high-level event chain is specified based on a sequence of available event chains which play the role of event chain *segments*. For this high-level event chain a time budget shall be specified. Finally, the aggregated time budget needs to be

assessed if acceptable which means that the aggregated time budget shall be equal or less than the time budget of the high-level event chain.

Figure 6.2 shows the connected event chains *EC1*, *EC2* and *EC3*. For each event chain a time budget, using a `LatencyTimingConstraint`, is specified: The time budget of event chain *EC1* is 0.5 ms, of event chain *EC2* is 0.6 ms and of event chain *EC3* is 0.7 ms. The high-level event chain *EC* is a composition of the event chains *EC1*, *EC2* and *EC3*. The stimulus event of the high-level event chain is the event "requesting the brake pedal position" (*Stimulus*) and the response event of the high-level event chain is the event "making available the determined vehicle speed" (*Response*). Eventually, a time budget is assigned to the high-level event chain using a `LatencyTimingConstraint`, for example 2 ms. This value is consistent with the aggregated time budget of the event chain segments (0.5 ms + 0.6 ms + 0.7 ms = 1.8 ms).

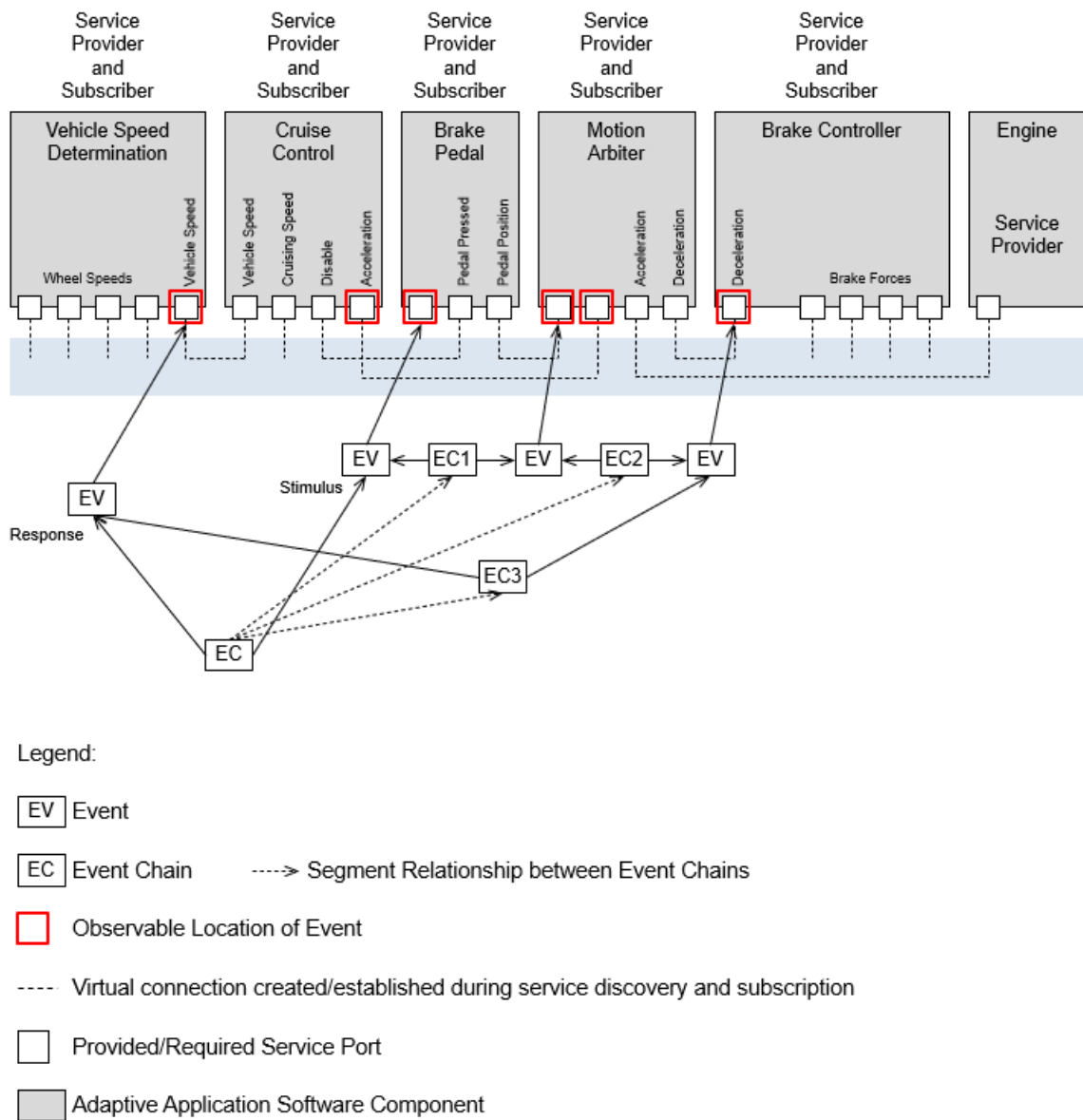

Figure 6.2: Example of a composed and decomposed event chain

6.2 Patterns

A sequence or hierarchy of event chains can form complex structures. However, if one of the aforementioned approaches is correctly followed then there is only a handful of patterns applicable. These patterns are introduced in the following with a simple example.

6.2.1 Sequence

The most frequently used pattern is the sequence of events. Such a sequence describes a succession of causally related events without an alternative path.

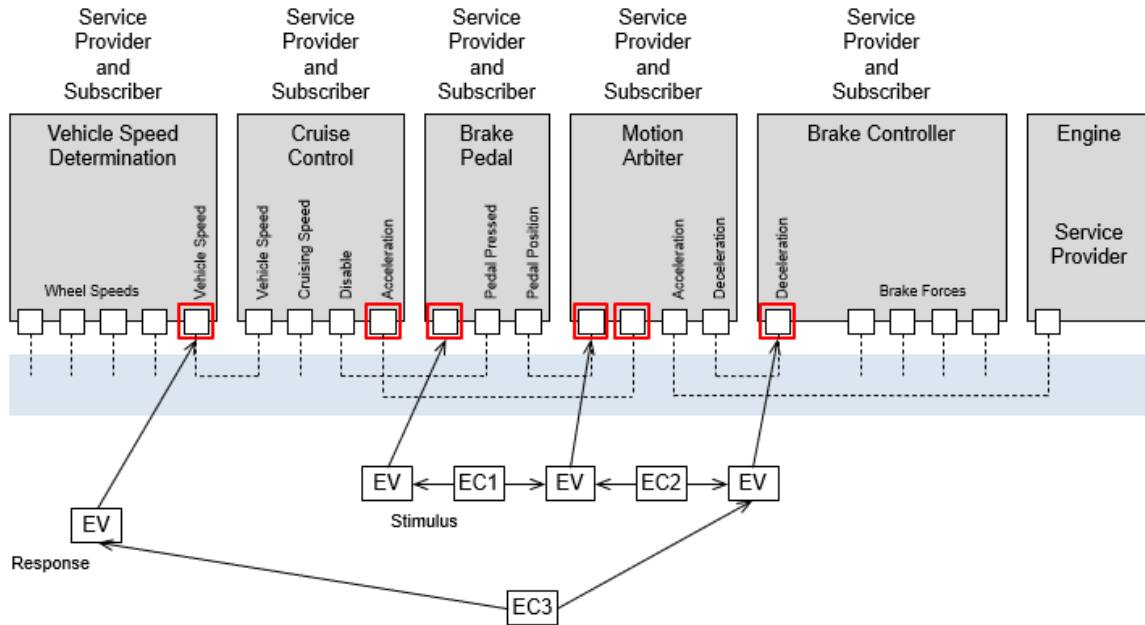

Legend:

EV Event

EC Event Chain

 Observable Location of Event

----- Virtual connection created/established during service discovery and subscription

 Provided/Required Service Port

 Adaptive Application Software Component

Figure 6.3: Example of the "Sequence" pattern

An example for this pattern is depicted in Figure 6.3. The event chains *EC1* through *EC3* define a causal relationship of events observed at a service port of the adaptive application software component called *Brake Pedal* and a service port of the adaptive application software component called *Vehicle Speed Determination*.

6.2.2 Fork

The "Fork" pattern describes the constellation where several event chains have one common stimulus event and different response events.

The pattern is illustrated in Figure 6.4, which shows a path that forks because the adaptive application software component *Brake Controller* calculates the brake force value for each wheel (*EC5* through *EC8*).

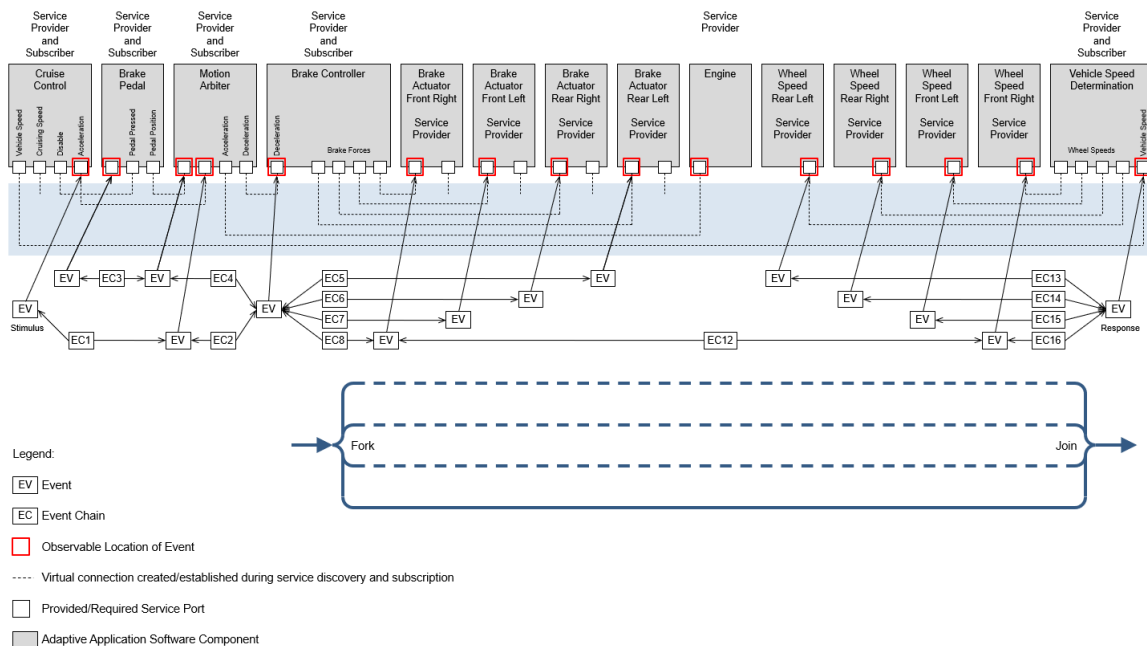

Figure 6.4: Example of the "Fork" and "Join" pattern

6.2.3 Join

The "Join" pattern describes the constellation where several event chains have one common response event and different stimulus events.

The pattern is illustrated in Figure 6.4 which shows a path that joins because the adaptive application software component *Vehicle Speed Determination* aggregates the wheel speed values from individual wheels (*EC13* through *EC16*).

6.2.4 Alternative

The "Alternative" pattern describes the constellation where more than one path between a stimulus and response event exists. This implies that at least one "Fork" is followed by at least one "Join".

The pattern is illustrated in Figure 6.5 which shows that an event observed at a required service port of the adaptive application software component *Motion Arbiter* leads to an occurrence of an event either at the provided service port called *Deceleration* of the adaptive application software component *Brake Controller*, or at the provided service port called *Acceleration* of the adaptive application software component *Engine*. These alternative causal relationships are described by the event chains *EC2* and *EC4* in this figure. In either case, the deceleration or acceleration of the vehicle leads to the occurrence of an event at the provided service port called *Vehicle Speed* of the adaptive application software component *Vehicle Speed Determination* reporting the vehicle's speed. These alternative causal relationships are described by the event chains *EC3* and *EC5* which both reference the same response event. To fulfill the overall event chain, only one of the alternative paths shall have been occurred.

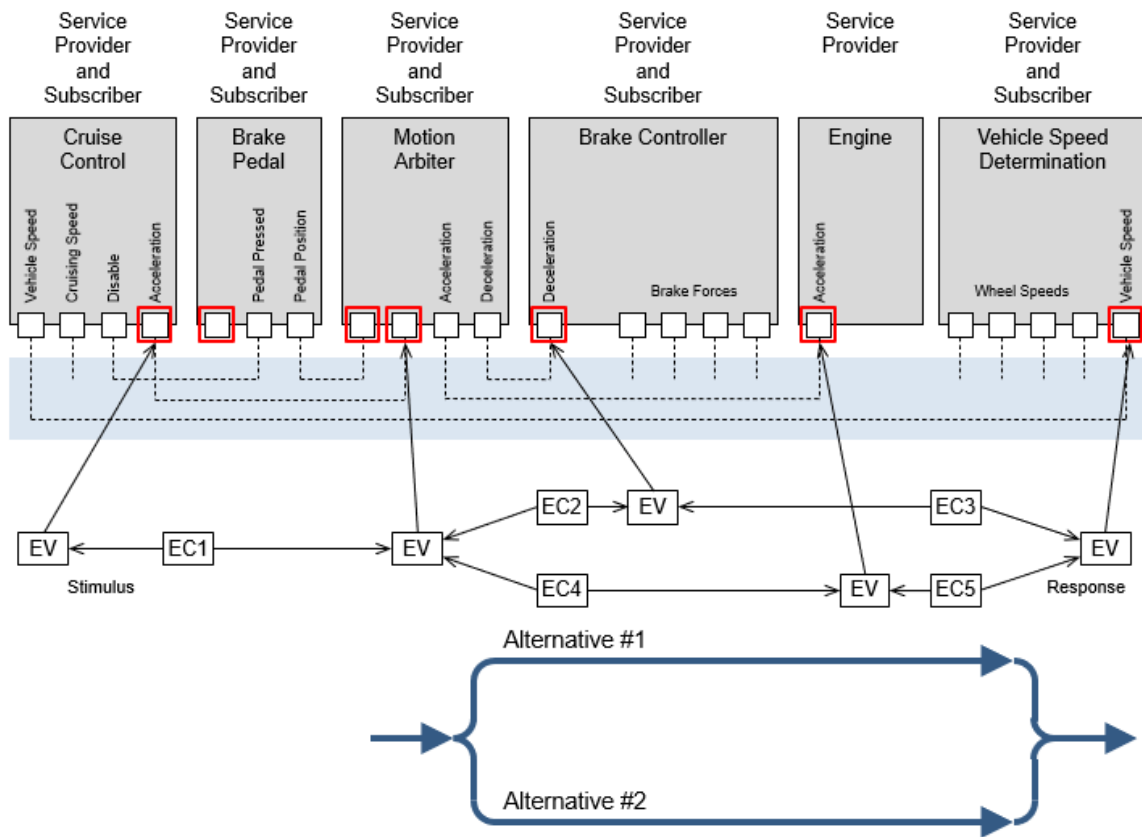

Legend:

EV Event

EC Event Chain

Observable Location of Event

Virtual connection created/established during service discovery and subscription

Provided/Required Service Port

Adaptive Application Software Component

Figure 6.5: Example of the "Alternative" pattern

6.2.5 Cycle

The "Cycle" pattern describes the constellation where a path from the response event of an event chain leads to the stimulus of this event chain.

The pattern is illustrated in Figure 6.6 which shows three event chains *EC8*, *EC12* and *EC17* forming a cycle. The stimulus event of event chain *EC8* is the response event of

event chain *EC17*; and the response event of event chain *EC12* is the stimulus event of event chain *EC17*. Event chain *EC8* and *EC12* reference the same event in different roles, namely response event from event chain *EC8* perspective and stimulus event from the event chain *EC12* perspective.

Note that an event chain referencing the same event for its stimulus and its response is forbidden according to the constraint [constr_4581]. As a consequence a cycle consists of at least two event chains.

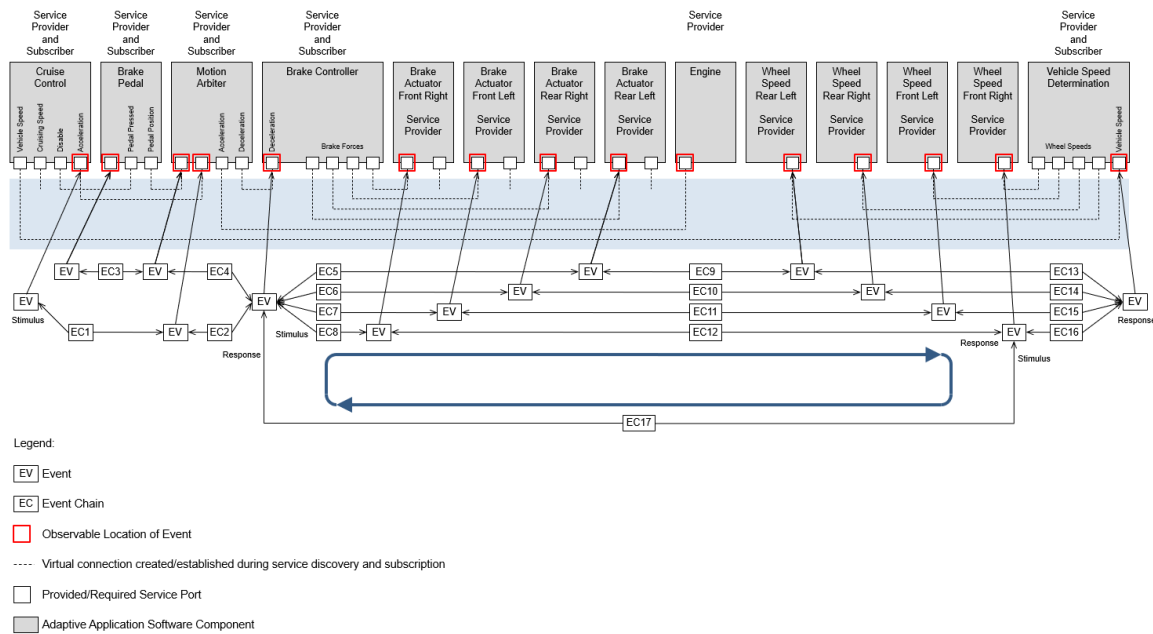

Figure 6.6: Example of the "Cycle" pattern

7 Timing Constraints

Timing constraints can be applied either on Timing Description Events or on Timing Description Event Chains. Applied to Timing Description Events a Timing Constraint classifies a single event or a group of events with a temporal restriction, for example a period, a latency or a time interval considered as synchronous. Also the direction has to be considered, which means in the semantics of the constraint it matters whether an event source (forward semantics) or an event sink (backward semantics) is considered. Applied to Timing Description Event Chains a condition or property for this event chain is set. As the event chain has a semantic of a directed acyclic graph, the direction is obvious, but it matters whether a single event chain or a group of event chains are constrained.

Mentioned in context of a requirement specification, Timing Constraints can be used as functional requirements and therefore can be tested. For usage in context of a performance specification, Timing Constraints can be used as system properties or

timing guarantees. The following table gives an overview over scope and usage of the different types of Timing Constraints described in the following chapters:

<i>Constraint</i>	<i>Imposed on</i>	<i>Use Case</i>
Event Triggering	TimingDescriptionEvent	Specification of an activation Model
Latency Timing	TimingDescriptionEventChain	End-to-End path latency (in reaction or max age semantics)
Age	TimingDescriptionEvent	Restriction
Synchronization Timing	TimingDescriptionEventChain	Restrictions for forks and joins of event chains
Synchronization Timing	TimingDescriptionEvent	Restriction
Offset Timing	TimingDescriptionEvent	Restriction

Table 7.1: Constraints

7.1 EventTriggeringConstraint

[TPS_TIMEX_00071]{DRAFT} **EventTriggeringConstraint** specifies occurrence behavior respectively model [The element [EventTriggeringConstraint](#) is used to specify the particular occurrences of a given timing description event.] ([RS_TIMEX_00001](#), [RS_TIMEX_00002](#), [RS_TIMEX_00006](#), [RS_TIMEX_00008](#))

AUTOSAR offers five basic types of event triggering as depicted in Figure 7.1.

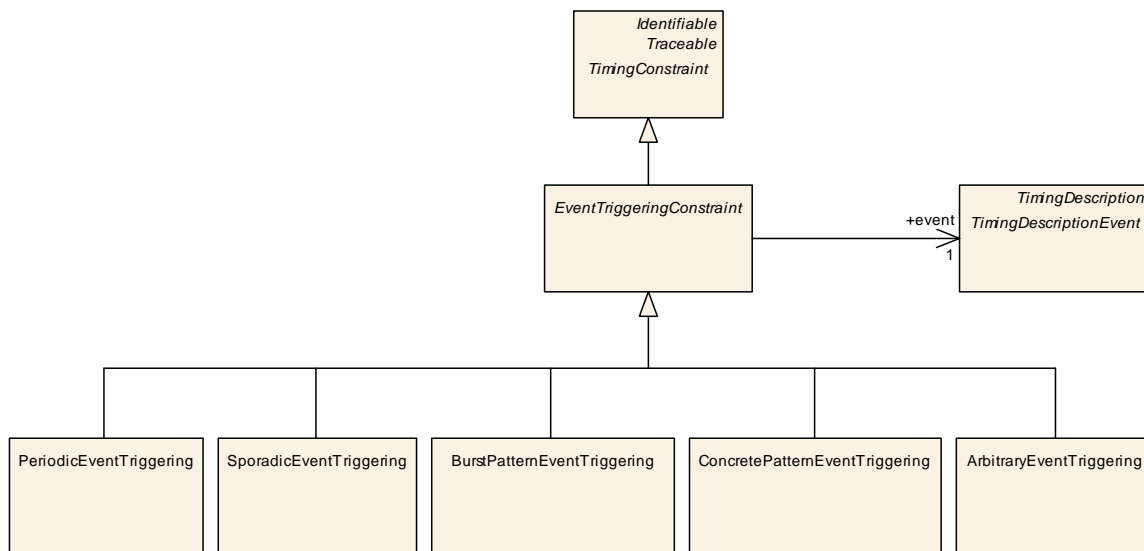

Figure 7.1: The different types of event triggerings

Class	<i>EventTriggeringConstraint</i> (abstract)			
Package	M2::AUTOSARTemplates::CommonStructure::Timing::TimingConstraint::EventTriggeringConstraint			
Note	Describes the occurrence behavior of the referenced timing event. The occurrence behavior can only be determined when a mapping from the timing events to the implementation can be obtained. However, such an occurrence behavior can also be described by the modeler as an assumption or as a requirement about the occurrence of the event.			
Base	<i>ARObject</i> , <i>Identifiable</i> , <i>MultilanguageReferrable</i> , <i>Referrable</i> , <i>TimingConstraint</i> , <i>Traceable</i>			
Subclasses	<i>ArbitraryEventTriggering</i> , <i>BurstPatternEventTriggering</i> , <i>ConcretePatternEventTriggering</i> , <i>PeriodicEventTriggering</i> , <i>SporadicEventTriggering</i>			
Attribute	Type	Mult.	Kind	Note
event	TimingDescriptionEvent	1	ref	The referenced timing event

Table 7.2: EventTriggeringConstraint

7.1.1 PeriodicEventTriggering

[TPS_TIMEX_00076]{DRAFT} **PeriodicEventTriggering** specifies periodic occurrences of events [The element [PeriodicEventTriggering](#) is used to specify the characteristics of a timing description event which occurs periodically.] ([RS_TIMEX_00001](#), [RS_TIMEX_00002](#), [RS_TIMEX_00006](#), [RS_TIMEX_00008](#))

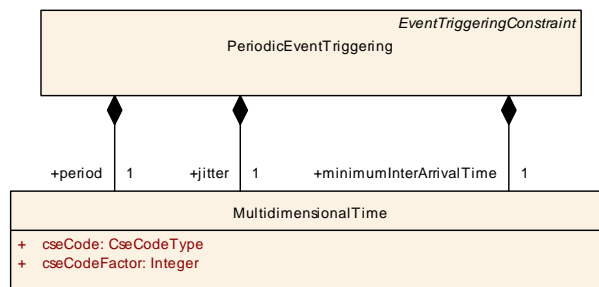

Figure 7.2: PeriodicEventTriggering

Class	PeriodicEventTriggering			
Package	M2::AUTOSARTemplates::CommonStructure::Timing::TimingConstraint::EventTriggeringConstraint			
Note	The <i>PeriodicEventTriggering</i> describes the behavior of an event with a strict periodic occurrence pattern, given by the period attribute. Additionally, it is possible to soften the strictness of the periodic occurrence behavior by specifying a jitter, so that there can be a deviation from the period up to the size of the jitter.			
Base	<i>ARObject</i> , <i>EventTriggeringConstraint</i> , <i>Identifiable</i> , <i>MultilanguageReferrable</i> , <i>Referrable</i> , <i>TimingConstraint</i> , <i>Traceable</i>			
Attribute	Type	Mult.	Kind	Note
jitter	MultidimensionalTime	1	aggr	The maximum jitter of the periodic event occurrence. Tags: xml.sequenceOffset=20
minimumInterArrivalTime	MultidimensionalTime	1	aggr	The minimum time distance between two consecutive occurrences of the associated event. Tags: xml.sequenceOffset=10



△

Class	PeriodicEventTriggering			
period	MultidimensionalTime	1	aggr	The period of the event occurrence. Tags: xml.sequenceOffset=30

Table 7.3: PeriodicEventTriggering

The Periodic Event Triggering is characterized by the following parameters:

- Period
- Jitter
- Minimum Inter-Arrival Time

The listed parameters are required ones and are described in the following.

Period This parameter `period` specifies the periodic distance between subsequent occurrences of the event.

Jitter This parameter `jitter` specifies the maximum deviation from the period.

Minimum Inter-Arrival Time This parameter `minimumInterArrivalTime` specifies the minimum distance between subsequent occurrences of the event. Note, that if the value of the parameter `minimumInterArrivalTime` is less than the value of the parameter `period` minus the value of the parameter `jitter`, then the parameter `minimumInterArrivalTime` has no effect on the properties of the periodic event triggering constraints.

[constr_4589]{DRAFT} Maximum value of the parameter `minimumInterArrivalTime` [The value of the parameter `minimumInterArrivalTime` shall be less than or equal the value of the parameter `period`.]()

Let t_n be the point-in-time of the n -th occurrence of the event. A Periodic Event Triggering Constraint is satisfied if, and only if at least one reference point-in-time $t_{reference}$ exists such that for every occurrence of the event at t_n the following holds true: $t_{reference} + (n - 1)period \leq t_n \leq t_{reference} + (n - 1)period + jitter$ and for all of those event occurrences the minimum distance shall be less than or equal to `minimumInterArrivalTime`.

$$\exists t_{reference} \mid \forall n : t_{reference} + (n - 1)period \leq t_n \leq t_{reference} + (n - 1)period + jitter$$

$$AND \quad \forall n : t_{n+1} - t_n \leq minimumInterArrivalTime$$

Figure 7.3 illustrates the parameters of the `PeriodicEventTriggering`. The upper part of this figure shows the case that the value of `jitter` is less than the value of the parameter `period`; whereas the lower part of this figure shows the case that the value of `jitter` is greater than or equal the value of the parameter `period`.

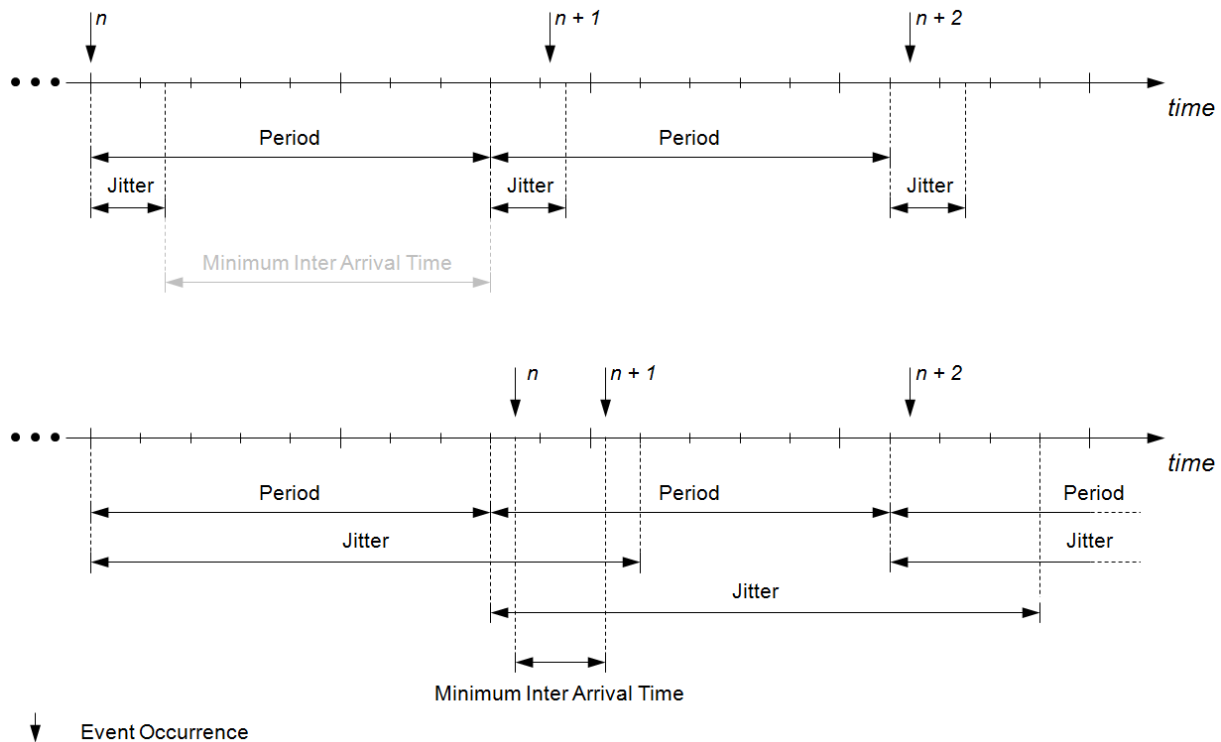

Figure 7.3: Parameters characterizing the Periodic Event Triggering

7.1.1.1 Examples

A Periodic Event Triggering Constraint is specified with the following parameters: `period` is six milliseconds (6ms) and `jitter` is two milliseconds (2ms). In other words, one imposes a timing constraint on an event to occur every six milliseconds and specifies that a deviation of two milliseconds is tolerable. In addition, it is assumed that the `minimumInterArrivalTime` is one millisecond (1ms) and therefore has no impact on the timing of the event’s occurrences. This timing constraint is shown in Figure 7.4. The repeating gray-colored rectangles in this figure indicate the time intervals during which the event may occur; in other words it marks the subsequent time intervals the event is expected to occur.

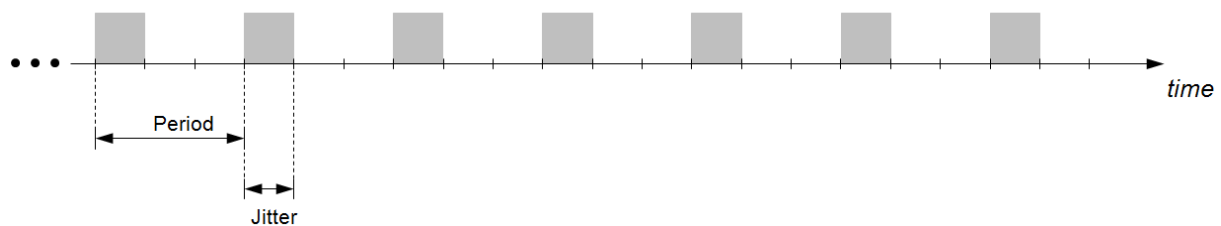

Figure 7.4: Example of a Periodic Event Triggering Constraint

The following figures show various event occurrences recorded during the observation of a system subject to analysis. The time interval for the observation is given by $t_{end-observation} - t_{start-observation}$. In the given example the system is observed for a period of 33.6 milliseconds.

The subsequent event occurrences shown in Figure 7.5 satisfy the given periodic event triggering constraint, because all occurrences of the event observed during the observation time interval happen in their corresponding time interval given by *period* and *jitter*.

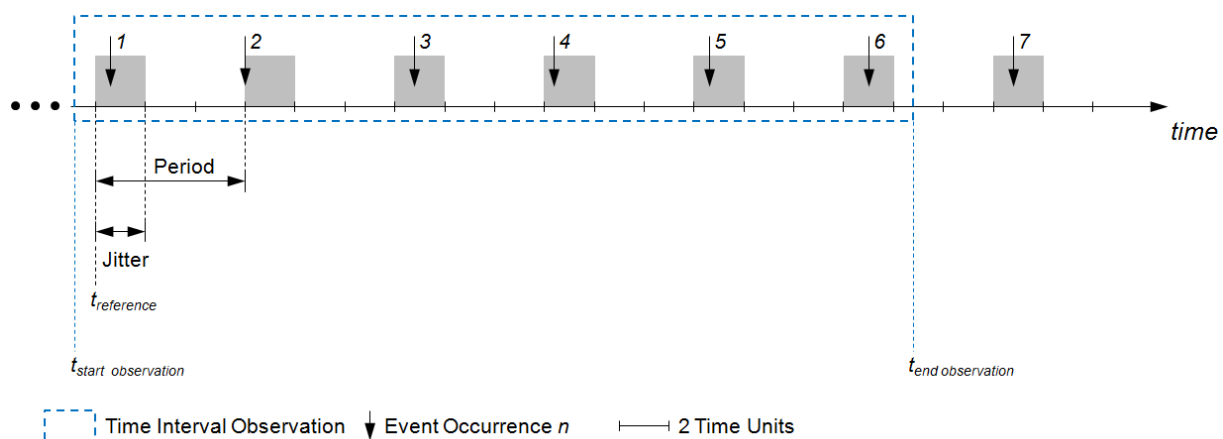

Figure 7.5: Event occurrences satisfying the given Period Event Triggering Constraint shown in the example at the beginning of this subsection.

The subsequent event occurrences shown in Figure 7.6 satisfy the given periodic event triggering constraint, because all occurrences of the event observed during the observation time interval happen in their corresponding time interval given by *period* and *jitter*. In contrast to the example shown in Figure 7.5 the reference point-in-time is another one.

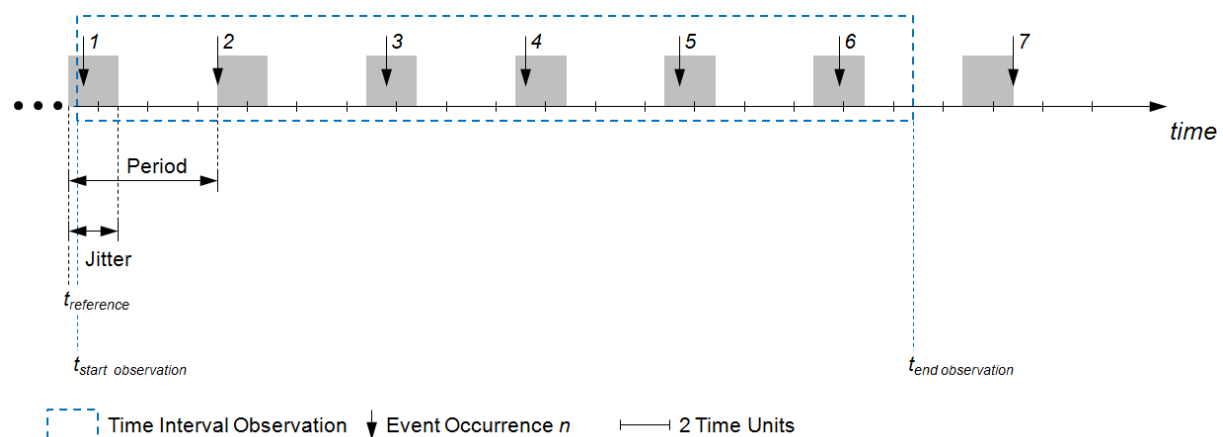

Figure 7.6: Event occurrences satisfying the given Period Event Triggering Constraint shown in the example at the beginning of this subsection, but with another reference point-in-time $t_{reference}$.

The subsequent event occurrences shown in Figure 7.7 violate the given periodic event triggering constraint, because the fifth occurrence of the event does not happen in its corresponding time interval given by *period* and *jitter*. In other words, there does not exist a reference point-in-time that ensures that all occurrences of the event observed during the observation time interval happen in their corresponding time interval given by *period* and *jitter*. And this results in a violation of the parameters *period* and *jitter*.

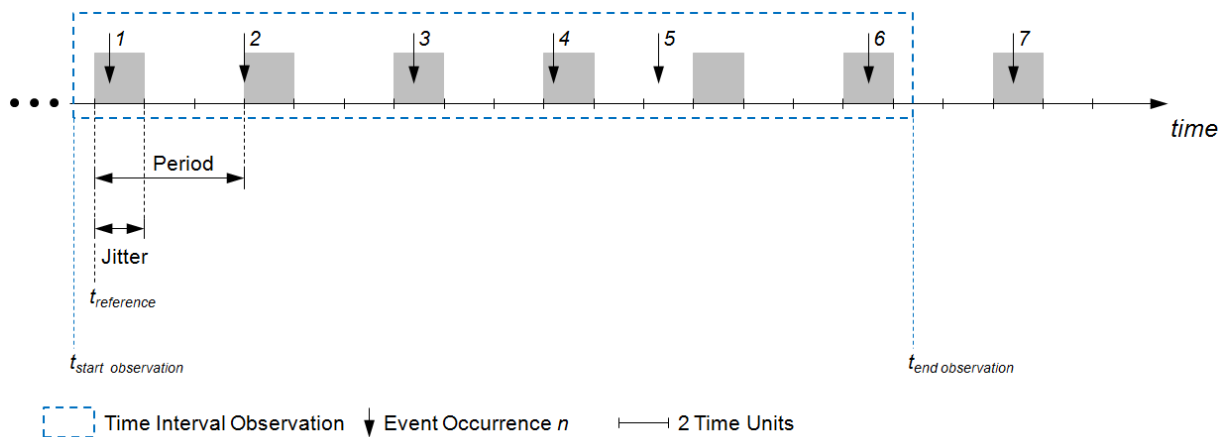

Figure 7.7: Event occurrences violating the given Period Event Triggering Constraint shown in the example at the beginning of this subsection.

The subsequent event occurrences shown in Figure 7.8 violate the given periodic event triggering constraint, because the fourth occurrence of the event does not happen in its corresponding time interval given by *period* and *jitter*. In other words, the fourth occurrence of the event happens in the time interval the fifth occurrence of the event happens and therefore violates the specified *jitter*.

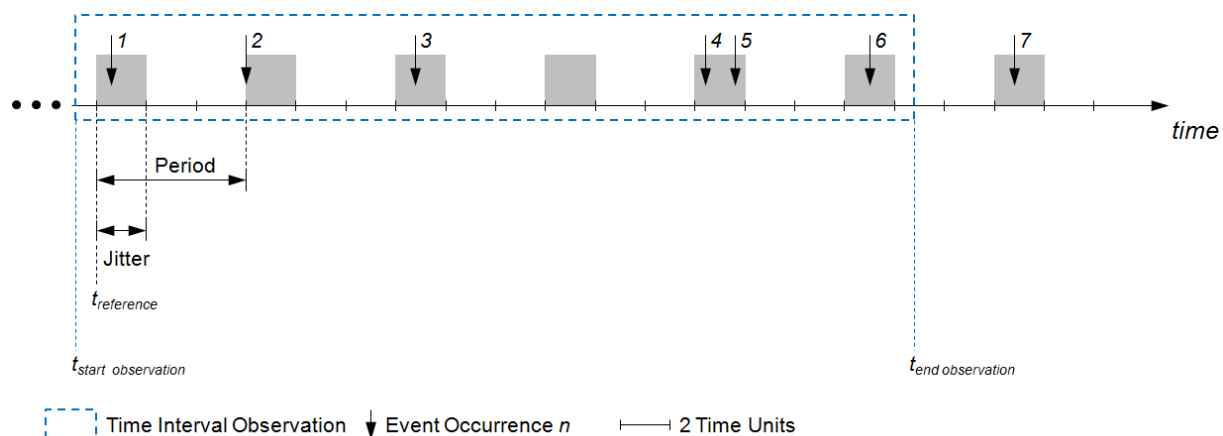

Figure 7.8: Event occurrences satisfying the given Period Event Triggering Constraint shown in the example at the beginning of this subsection.

7.1.2 SporadicEventTriggering

[TPS_TIMEX_00077]{DRAFT} **SporadicEventTriggering** specifies sporadic occurrences of events [The element `SporadicEventTriggering` is used to specify the characteristics of a timing description event which occurs sporadically.] ([RS_TIMEX_00001](#), [RS_TIMEX_00002](#), [RS_TIMEX_00006](#), [RS_TIMEX_00008](#))

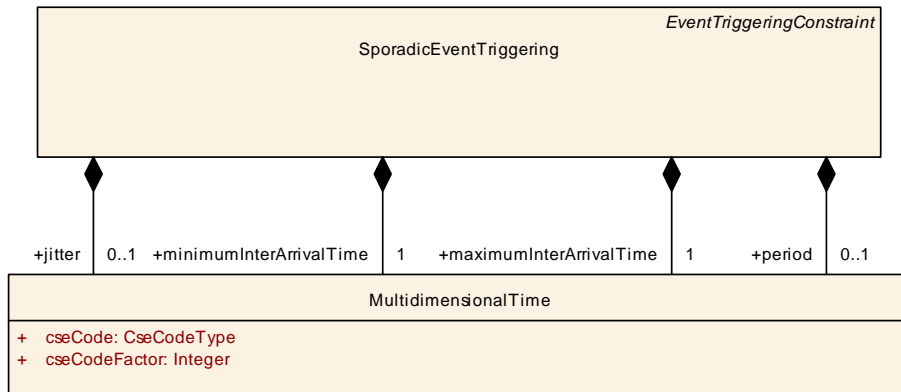

Figure 7.9: SporadicEventTriggering

Class	SporadicEventTriggering			
Package	M2::AUTOSARTemplates::CommonStructure::Timing::TimingConstraint::EventTriggeringConstraint			
Note	The SporadicEventTriggering describes the behavior of an event which occurs occasionally or singly.			
Base	ARObject, EventTriggeringConstraint, Identifiable, MultilanguageReferrable, Referrable, TimingConstraint, Traceable			
Attribute	Type	Mult.	Kind	Note
jitter	MultidimensionalTime	0..1	aggr	The maximum jitter of the sporadic event occurrence. Jitter=max nthPeriod - standardPeriod Tags: xml.sequenceOffset=30
maximumInterArrivalTime	MultidimensionalTime	1	aggr	The maximum time distance between two consecutive occurrences of the associated event. Tags: xml.sequenceOffset=20
minimumInterArrivalTime	MultidimensionalTime	1	aggr	The minimum time distance between two consecutive occurrences of the associated event. Tags: xml.sequenceOffset=10
period	MultidimensionalTime	0..1	aggr	The period of the event occurrence. Tags: xml.sequenceOffset=40

Table 7.4: SporadicEventTriggering

This is a generalization of the periodic event triggering described in subsection 7.1.1. The difference is that the event can, but not necessarily shall occur. For this reason, there is one additional parameter required for the specification of the `SporadicEventTriggering`, namely the `maximumInterArrivalTime`, which specifies the largest possible time distance between two event occurrences.

The Sporadic Event Triggering is characterized by the following parameters:

- Minimum Inter-Arrival Time

- Maximum Inter-Arrival Time
- Period
- Jitter

The first two parameters are required ones and the last two parameters are optional. These parameters are described in the following and Figure 7.10 illustrates the parameters of the `SporadicEventTriggering`.

Minimum Inter-Arrival Time This parameter `minimumInterArrivalTime` specifies the minimum distance between subsequent occurrences of the event.

Maximum Inter-Arrival Time This parameter `maximumInterArrivalTime` specifies the maximum distance between subsequent occurrences of the event.

Period This optional parameter `period` specifies the periodic distance between subsequent occurrences of the event.

Jitter This optional parameter `jitter` specifies the maximum deviation from the period.

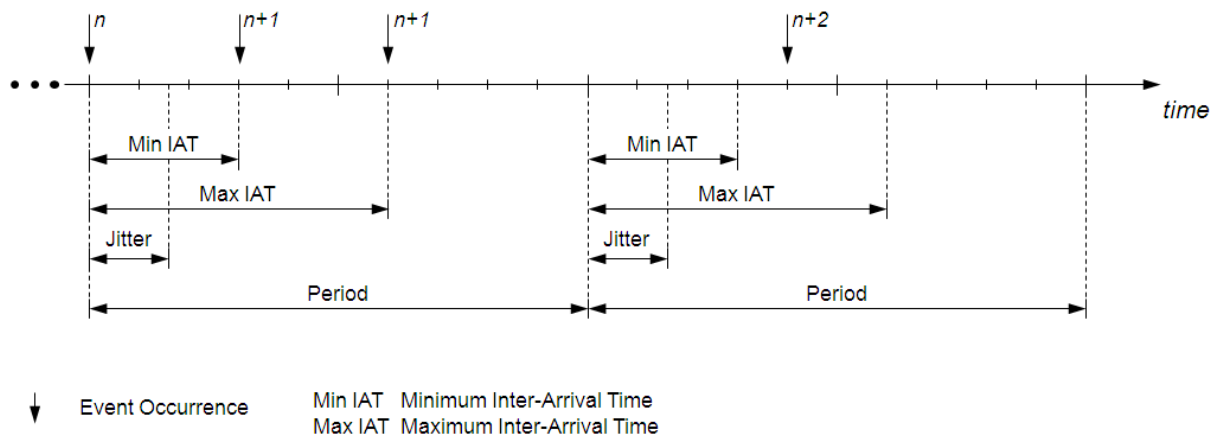

Figure 7.10: Parameters characterizing the Sporadic Event Triggering

7.1.3 ConcretePatternEventTriggering

[TPS_TIMEX_00078]{DRAFT} `ConcretePatternEventTriggering` specifies concrete pattern of occurrences of events [The element `ConcretePatternEventTriggering` is used to specify the characteristics of a timing description event which occurs as a concrete pattern.]([RS_TIMEX_00001](#), [RS_TIMEX_00002](#), [RS_TIMEX_00006](#), [RS_TIMEX_00008](#))

This describes events which occur following a known pattern.

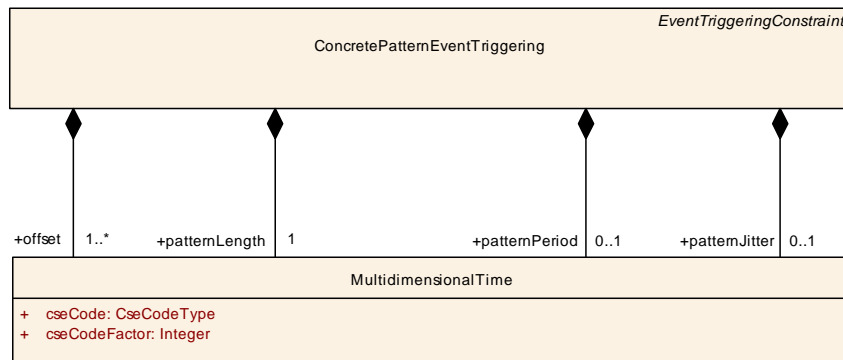

Figure 7.11: ConcretePatternEventTriggering

Class	ConcretePatternEventTriggering			
Package	M2::AUTOSARTemplates::CommonStructure::Timing::TimingConstraint::EventTriggeringConstraint			
Note	The ConcretePatternEventTriggering describes the behavior of an event, which occurs following a precisely known pattern.			
Base	ARObject, EventTriggeringConstraint , Identifiable , MultilanguageReferrable , Referrable , TimingConstraint , Traceable			
Attribute	Type	Mult.	Kind	Note
offset	MultidimensionalTime	1..*	aggr	The offset for each occurrence of the event in the specified time interval. Tags: xml.name=TIME-VALUE xml.roleElement=true xml.sequenceOffset=10 xml.typeElement=false
patternJitter	MultidimensionalTime	0..1	aggr	The optional parameter "Pattern Jitter" specifies the deviation of the time interval's starting point from the beginning of the given period. This parameter is only applicable in conjunction with the parameter "Pattern Period".
patternLength	MultidimensionalTime	1	aggr	The length of the observed time interval. Tags: xml.sequenceOffset=20
patternPeriod	MultidimensionalTime	0..1	aggr	The optional parameter "Pattern Period" specifies the time distance between the beginnings of subsequent repetitions of the given concrete pattern.

Table 7.5: ConcretePatternEventTriggering

The Concrete Pattern Event Triggering is characterized by the following parameters:

- Pattern Length
- Offset
- Pattern Period
- Pattern Jitter

The first two parameters are required ones, whereas the two last parameters are optional. The parameters are described in the following and are illustrated in Figure 7.13 and Figure 7.13.

Pattern Length This parameter `patternLength` specifies the time interval the pattern occurs in.

Offset This parameter `offset` specifies a list of point-in-times in the time interval given by the parameter `patternLength` at which the event occurs.

Pattern Period This optional parameter `patternPeriod` specifies the time distance between the beginnings of subsequent repetitions of the given burst pattern.

Pattern Jitter This optional parameter `patternJitter` specifies the maximum deviation of the time interval's starting point from the beginning of the given period. This parameter is only applicable in conjunction with the parameter `patternPeriod`.

The constraints listed below apply to the `ConcretePatternEventTriggering` and shall be considered when using this event triggering constraint.

[constr_4585]{DRAFT} Specifying `patternLength` [The `patternLength` shall be specified such that the following holds: $0 \leq \max(\text{offset}) \leq \text{patternLength}$.]()

[constr_4590]{DRAFT} Specifying `patternLength`, `patternJitter` and `patternPeriod` [The pattern length, pattern jitter and pattern period shall be specified such that the following holds: $\text{patternLength} + \text{patternJitter} < \text{patternPeriod}$.]()

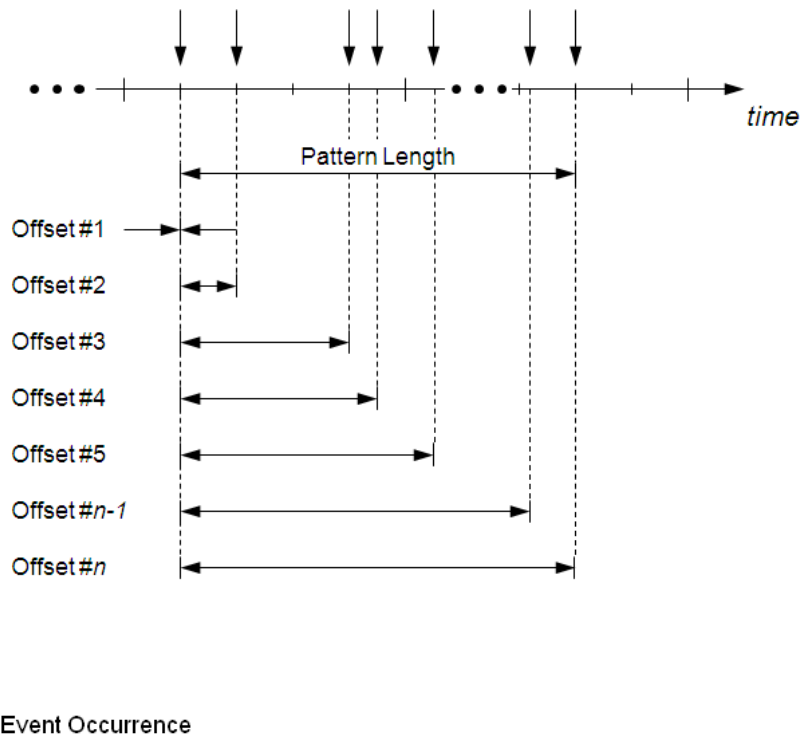

Figure 7.12: Parameters characterizing the Concrete Pattern Event Triggering

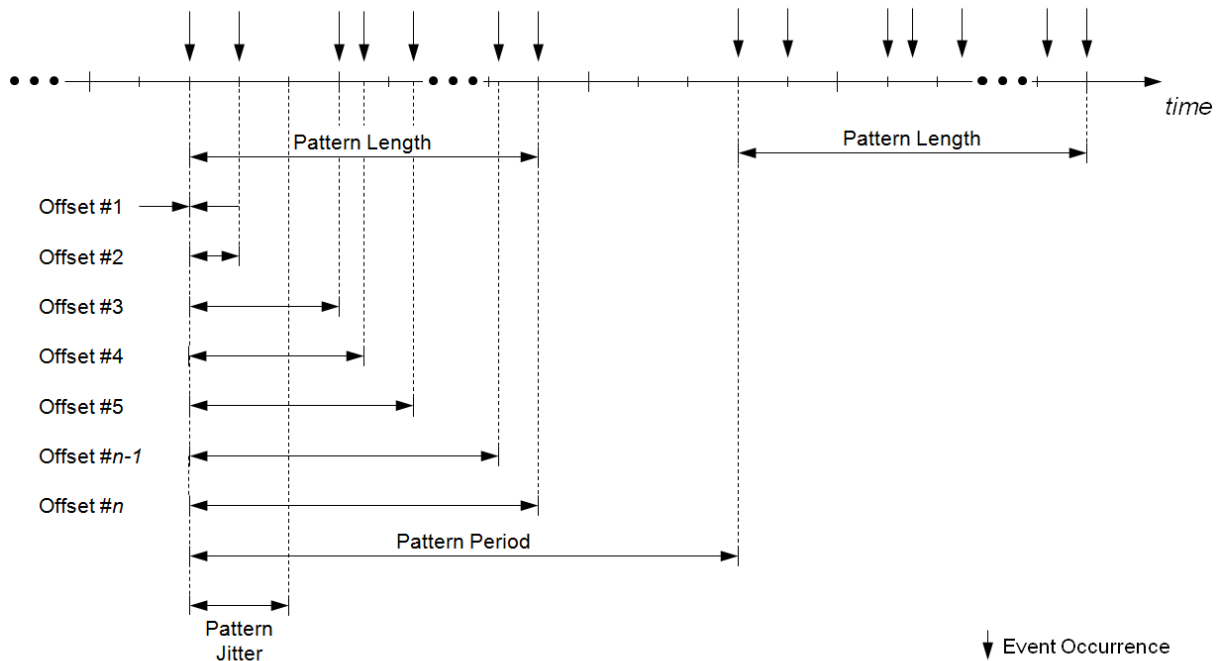

Figure 7.13: Parameters characterizing the Concrete Pattern Event Triggering when periodically being repeated

7.1.4 BurstPatternEventTriggering

[TPS_TIMEX_00079]{DRAFT} **BurstPatternEventTriggering** specifies burst of occurrences of events [The element *BurstPatternEventTriggering* is used to specify the characteristics of a timing description event which occurs as a burst.] (*RS_TIMEX_00001*, *RS_TIMEX_00002*, *RS_TIMEX_00006*, *RS_TIMEX_00008*)

The purpose of the *BurstPatternEventTriggering* is to describe a burst of occurrences of one and the same event. The Burst Pattern Event Triggering is characterized by the following parameters:

- Pattern Length
- Minimum Inter Arrival Time
- Maximum Number of Occurrences
- Minimum Number of Occurrences
- Pattern Period
- Pattern Jitter

The first three parameters are required ones, whereas the last three parameters are optional.

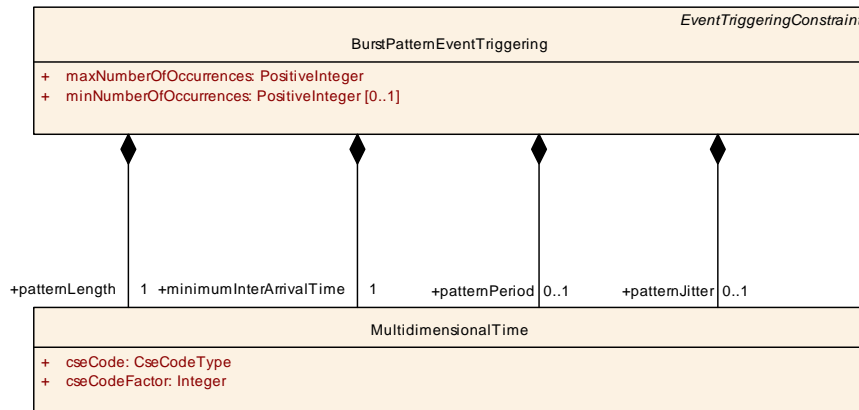

Figure 7.14: BurstPatternEventTriggering

Class	BurstPatternEventTriggering			
Package	M2::AUTOSARTemplates::CommonStructure::Timing::TimingConstraint::EventTriggeringConstraint			
Note	A BurstPatternEventTriggering describes the maximum number of occurrences of the same event in a given time interval. This is typically used to model a worst case activation scenario.			
Base	ARObject, EventTriggeringConstraint , Identifiable , MultilanguageReferrable , Referrable , TimingConstraint , Traceable			
Attribute	Type	Mult.	Kind	Note
maxNumberOfOccurrences	PositiveInteger	1	attr	The maximum number of event occurrences within the given time interval.
minimumInterArrivalTime	MultidimensionalTime	1	aggr	The parameter "Minimum Inter-Arrival Time" specifies the minimum distance between subsequent occurrences of the event within the given time interval.
minNumberOfOccurrences	PositiveInteger	0..1	attr	The minimum number of event occurrences within the given time interval. Tags: xml.sequenceOffset=10
patternJitter	MultidimensionalTime	0..1	aggr	The optional parameter "Pattern Jitter" specifies the deviation of the time interval's starting point from the beginning of the given period. This parameter is only applicable in conjunction with the parameter "Pattern Period".
patternLength	MultidimensionalTime	1	aggr	The parameter "Pattern Length" specifies the duration of the time interval within which the event repeatedly occurs. The event occurs at arbitrary points in time within the given time interval.
patternPeriod	MultidimensionalTime	0..1	aggr	The optional parameter "Pattern Period" specifies the time distance between the beginnings of subsequent repetitions of the given burst pattern.

Table 7.6: BurstPatternEventTriggering

The parameters are described in the following and are illustrated in Figure 7.15 and Figure 7.16.

Pattern Length This parameter `patternLength` specifies the duration of the time interval within which the event repeatedly occurs. The event occurs at arbitrary points in time within the given time interval.

Minimum Inter-Arrival Time This parameter `minimumInterArrivalTime` specifies the minimum distance between subsequent occurrences of the event within the given time interval.

Maximum Number of Occurrences This parameter `maxNumberOfOccurrences` specifies the maximum number of times the event can occur within the time interval. In other words, the event may never occur or any number of times between one (1) and the specified maximum number of occurrences. If the parameter `minNumberOfOccurrences` is specified then the event occurs at least the number of times specified by `minNumberOfOccurrences` and at maximum by `maxNumberOfOccurrences`.

Minimum Number of Occurrences This optional parameter `minNumberOfOccurrences` specifies the minimum number of times the event occurs within the given time interval. In other words, this parameter specifies the minimum number of times the event occurs in the given time interval. The value zero (0) for this parameter is permitted.

Pattern Period This optional parameter `patternPeriod` specifies the time distance between the beginnings of subsequent repetitions of the given burst pattern.

Pattern Jitter This optional parameter `patternJitter` specifies the maximum deviation of the time interval's starting point from the beginning of the given period. This parameter is only applicable in conjunction with the parameter `patternPeriod`.

The constraints listed below apply to the `BurstPatternEventTriggering` and shall be considered when using this event triggering constraint.

[constr_4574]{DRAFT} Specifying minimum and maximum number of occurrences [The minimum and maximum number of occurrences shall be specified such that the following holds: $0 \leq \text{minNumberOfOccurrences} \leq \text{maxNumberOfOccurrences}$.]()

[constr_4575]{DRAFT} Specifying minimum inter-arrival time and pattern length [The minimum inter-arrival time and pattern length shall be specified such that the following holds: $0 < \text{minimumInterArrivalTime} \leq \text{patternLength}$.]()

[constr_4576]{DRAFT} Specifying pattern length, pattern jitter and pattern period [The pattern length, pattern jitter and pattern period shall be specified such that the following holds: $\text{patternLength} + \text{patternJitter} < \text{patternPeriod}$.]()

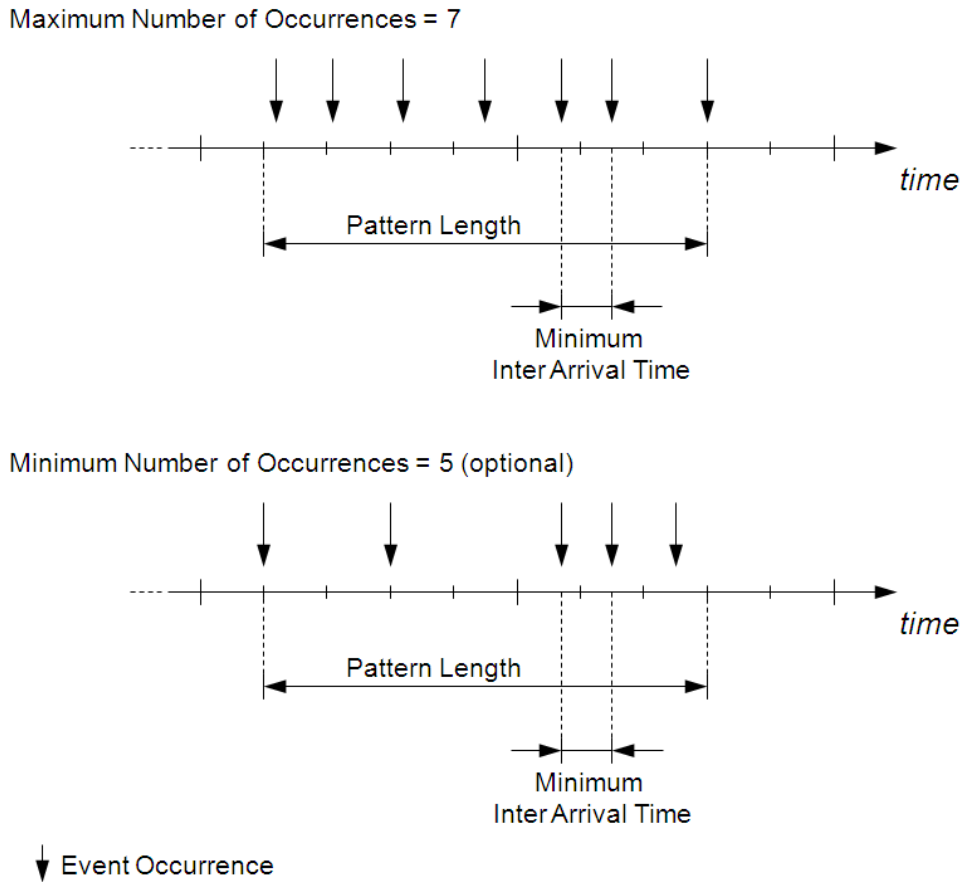

Figure 7.15: Parameters characterizing the Burst Pattern Event Triggering

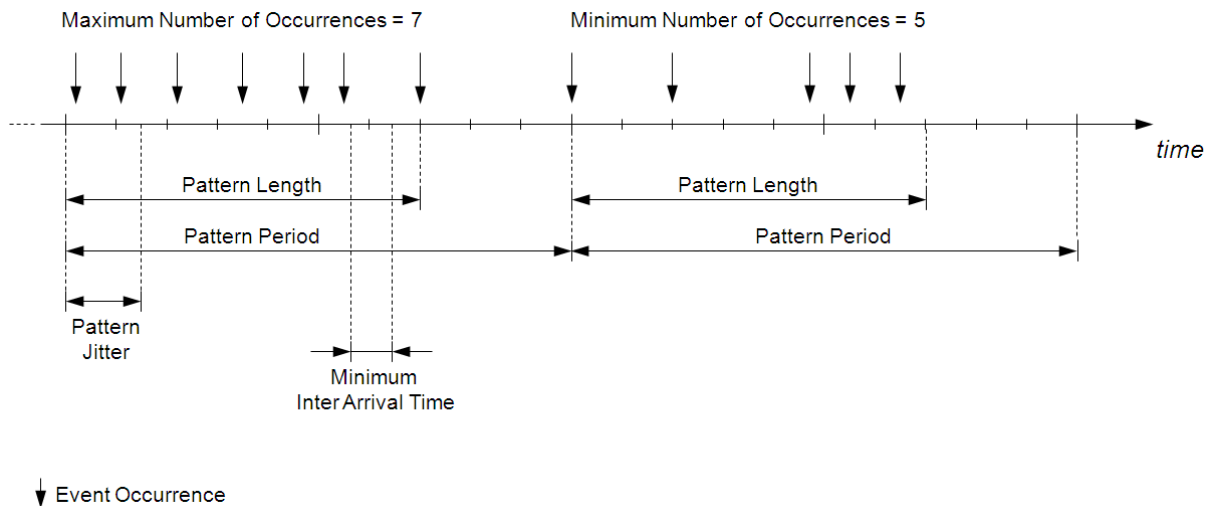

Figure 7.16: Parameters characterizing the Burst Pattern Event Triggering when periodically being repeated

7.1.5 ArbitraryEventTriggering

[TPS_TIMEX_00080]{DRAFT} **ArbitraryEventTriggering** specifies arbitrary occurrences of an event [The element `ArbitraryEventTriggering` is used to specify the characteristics of a timing description event which occurs arbitrarily.] ([RS_TIMEX_00001](#), [RS_TIMEX_00002](#), [RS_TIMEX_00006](#), [RS_TIMEX_00008](#))

This describes the occasional occurrence of a timing event.

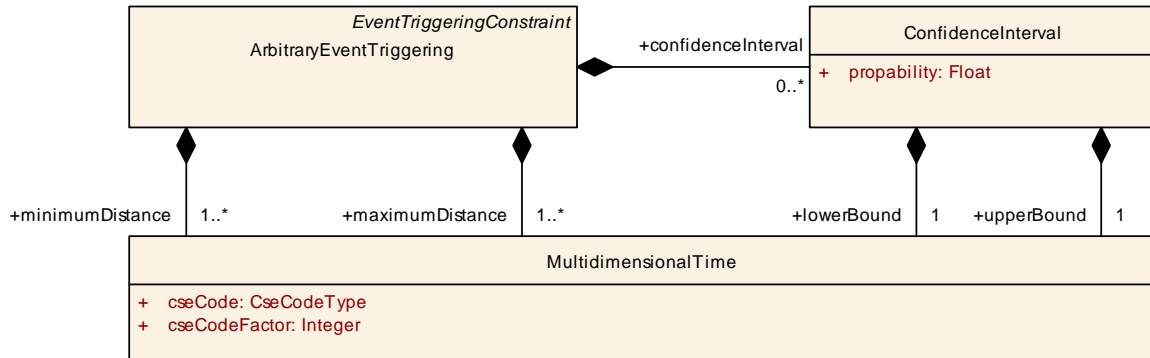

Figure 7.17: ArbitraryEventTriggering

Class	ArbitraryEventTriggering			
Package	M2::AUTOSARTemplates::CommonStructure::Timing::TimingConstraint::EventTriggeringConstraint			
Note	The ArbitraryEventTriggering describes that an event occurs occasionally, singly, irregularly or randomly. The primary purpose of this event triggering is to abstract event occurrences captured by data acquisition tools (background debugger, trace analyzer, etc.) during system runtime.			
Base	ARObject, EventTriggeringConstraint , Identifiable , MultilanguageReferrable , Referrable , TimingConstraint , Traceable			
Attribute	Type	Mult.	Kind	Note
confidence Interval	ConfidenceInterval	*	aggr	List of confidence intervals. Tags: xml.sequenceOffset=30
maximum Distance	MultidimensionalTime	1..*	aggr	The nth array element describes the maximum distance that can be observed for a sample of n+1 event occurrences. This is an array with an identical number of elements as for the minimumDistance. Tags: xml.name=TIME-VALUE xml.roleElement=true xml.sequenceOffset=20 xml.typeElement=false





Class	ArbitraryEventTriggering			
minimumDistance	MultidimensionalTime	1..*	aggr	<p>The nth array element describes the minimum distance that can be observed for a sample of n+1 event occurrences.</p> <p>This is an array with an identical number of elements as for the maximumDistance.</p> <p>Tags: xml.name=TIME-VALUE xml.roleElement=true xml.sequenceOffset=10 xml.typeElement=false</p>

Table 7.7: ArbitraryEventTriggering

Class	ConfidenceInterval			
Package	M2::AUTOSARTemplates::CommonStructure::Timing::TimingConstraint::EventTriggeringConstraint			
Note	Additionally to the list of measured distances of event occurrences, a confidence interval can be specified for the expected distance of two consecutive event occurrences with a given probability.			
Base	ARObject			
Attribute	Type	Mult.	Kind	Note
lowerBound	MultidimensionalTime	1	aggr	The lower bound of the expected distance of two consecutive event occurrences.
propability	Float	1	attr	The probability for the measured lower and upper bound of the confidence interval.
upperBound	MultidimensionalTime	1	aggr	The upper bound of the expected distance of two consecutive event occurrences.

Table 7.8: ConfidenceInterval

In contrast to the [ConcretePatternEventTriggering](#), this event triggering is not as strict to the occurrence of an event, but generally describes event occurrences.

The Arbitrary Event Triggering is characterized by the following parameters:

- Minimum Distance
- Maximum Distance

These parameters are required ones and are described in the following. Figure 7.18 illustrates the parameters of the [ArbitraryEventTriggering](#).

Minimum Distance The parameter [minimumDistance](#) specifies the minimum distance between n subsequent event occurrences, and $n = 2, 3, 4, \dots$

Maximum Distance The parameter [maximumDistance](#) specifies the maximum distance between n subsequent event occurrences, and $n = 2, 3, 4, \dots$

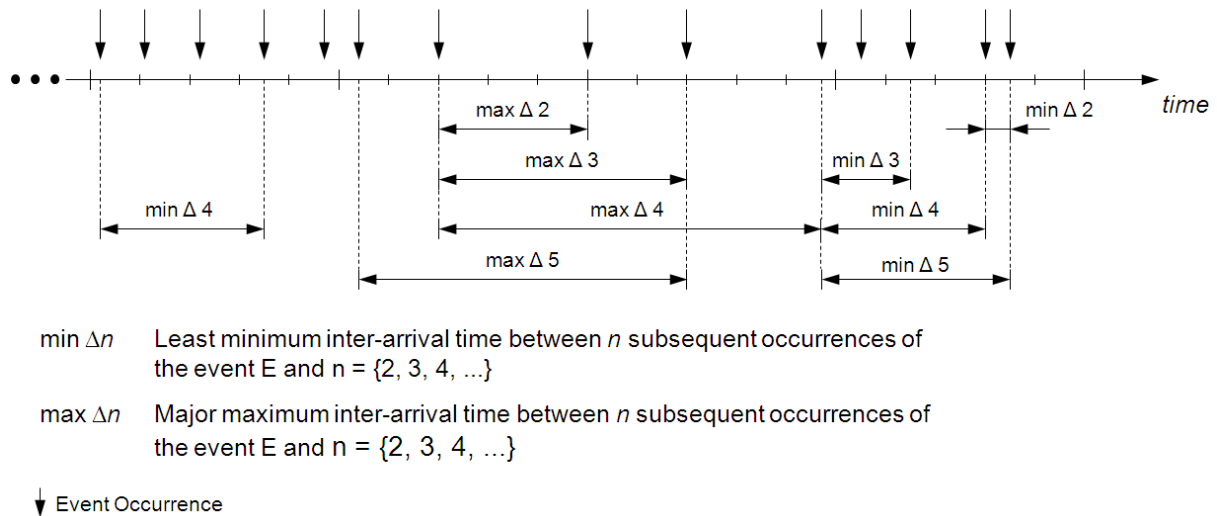

Figure 7.18: Parameters characterizing the Arbitrary Event Triggering

7.2 LatencyTimingConstraint

[TPS_TIMEX_00072]{DRAFT} **LatencyTimingConstraint** specifies latency constraints [The element `LatencyTimingConstraint`¹ is used to specify the amount of time that elapses between the occurrence of any two timing description events.] ([RS_TIMEX_00001](#), [RS_TIMEX_00002](#), [RS_TIMEX_00012](#))

For example, this can be the time it takes for a packet of data on a bus network to get from one designated point to another, or the time it takes for an executable to be executed on a processor.

In the timing specification a `LatencyTimingConstraint` is associated with one `TimingDescriptionEventChain`, and specifies the minimum and/or maximum time duration between the occurrence of the stimulus and the occurrence of the corresponding response of that chain.

Considering under- and oversampling, two end-to-end latency semantics are of interest for automotive systems and can thus be expressed with the AUTOSAR timing extensions. These are the *age* of a certain response and the *reaction* to a certain stimulus.

The *data age timing constraint* is mainly important in control engineering, but may appear in all domains. Here the focus is from the response perspective rather than from the stimulus perspective. In other words, the assumption is that last is best, i.e., it is accepted/tolerated that a value is overwritten along the path from stimulus to response. When for example an actuator value is periodically updated, it is of importance that the corresponding input values are not too old. In this case the constrained time of importance is the delay from the latest stimulus to a given response.

¹A synonym for delay

The *reaction time constraint* is utilized when the first reaction to a stimulus is of importance. This is usually the case in body electronics, but may also be the case in other domains. One example is the time it takes from a button is pressed to the light is switched on. Another example, from the chassis domain, is the time from the brake pedal is pressed until the brakes are activated. In both cases the constrained time of importance is the delay from a given stimulus to the first corresponding response.

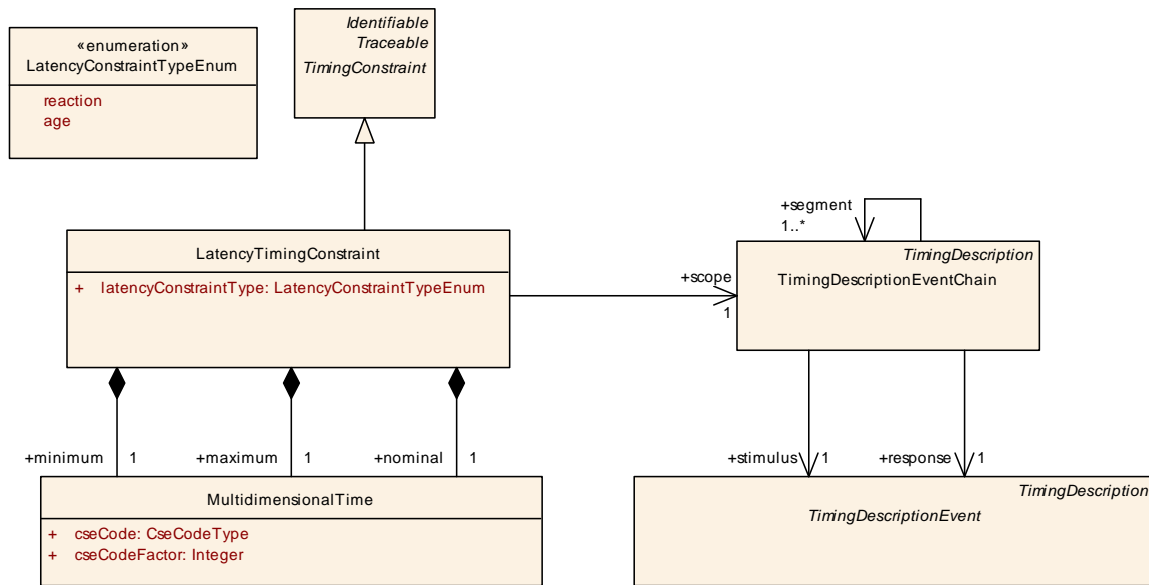

Figure 7.19: Latency constraint

Class	LatencyTimingConstraint			
Package	M2::AUTOSARTemplates::CommonStructure::Timing::TimingConstraint::LatencyTimingConstraint			
Note	<p>This constraint type restricts the time duration between the occurrence of the stimulus and the occurrence of the corresponding response of that chain.</p> <p>Two latency constraint types are of interest for automotive systems. These are the age of a certain response and the reaction to a certain stimulus.</p> <p>In contrast to OffsetTimingConstraint, a causal dependency between the stimulus and response event of the associated event chain is required.</p>			
Base	ARObject, Identifiable, MultilanguageReferrable, Referrable, TimingConstraint, Traceable			
Attribute	Type	Mult.	Kind	Note
latencyConstraintType	LatencyConstraintTypeEnum	1	attr	The specific type of this latency constraint.
maximum	MultidimensionalTime	1	aggr	The maximum latency between the occurrence of the stimulus and the occurrence of the corresponding response of the associated event chain. Tags: xml.sequenceOffset=20
minimum	MultidimensionalTime	1	aggr	The minimum latency between the occurrence of the stimulus and the occurrence of the corresponding response of the associated event chain. Tags: xml.sequenceOffset=10





Class	LatencyTimingConstraint			
nominal	MultidimensionalTime	1	aggr	The nominal latency between the occurrence of the stimulus and the occurrence of the corresponding response of the associated event chain. Tags: xml.sequenceOffset=30
scope	TimingDescriptionEventChain	1	ref	The event chain that defines the scope of the constraint.

Table 7.9: LatencyTimingConstraint

Enumeration	LatencyConstraintTypeEnum
Package	M2::AUTOSARTemplates::CommonStructure::Timing::TimingConstraint::LatencyTimingConstraint
Note	This is used to describe the type of the latency timing constraint.
Literal	Description
age	In this case, the latency constraint is seen from the perspective of the response event of the associated event chain. Given a certain response event, the age interval of the latest stimulus is constrained. Tags: atp.EnumerationLiteralIndex=0
reaction	In this case, the latency constraint is seen from the perspective of the stimulus event of the associated event chain. Given a certain stimulus event, the reaction interval of the first response is constrained. Tags: atp.EnumerationLiteralIndex=1

Table 7.10: LatencyConstraintTypeEnum

The attributes [minimum](#), [maximum](#), and [nominal](#) of a [LatencyTimingConstraint](#) can be used to define a lower and upper bound, as well as a nominal value for the latency of the event chain in the scope.

The application of latency constraints leads to some interesting observations:

- In systems without over- and undersampling, *age* and *reaction* are the same. But timing constraints are implementation-independent. Thus, at specification time when the implementation is not necessarily known, the correct latency constraint semantics has to be specified.
- The minimum reaction and the minimum age latency of an event chain are always equal.

7.3 AgeConstraint

Sometimes it is necessary to specify the age of data, when it arrives at a component on its required port with [SenderReceiverInterface](#). If the sender of the data is known, a [TimingDescriptionEventChain](#) can be defined from the sender to the receiver port and a [LatencyTimingConstraint](#) with *age* semantic represents the specification of the data age. However, the actual sender of the data may be unknown. In this case the definition of a [TimingDescriptionEventChain](#) is not possible.

[TPS_TIMEX_00073]{DRAFT} **AgeConstraint** to specify age constraints [The element *AgeConstraint* is used to specify a minimum and maximum age that is tolerated when a variable data prototypes is received.](RS_TIMEX_00001)

Instead of an event chain, the scope of an age constraint is a *TDEventVariableDataPrototype*. Every time the scoped event occurs, the *VariableDataPrototype* shall have the specified data age.

At a later stage during the development, when the refined software architecture exposes the relation between the actual sender of the data and the receiver, an event chain between the sending and receiving point in time shall be defined and associated with a *LatencyTimingConstraint* (see 7.2) in order to refine the previous defined age constraint.

Typically, the age constraint restricts the time interval between the physical creation of the original sensor data by the corresponding sensor hardware and the availability of the data in the communication buffer of the receiving SWC.

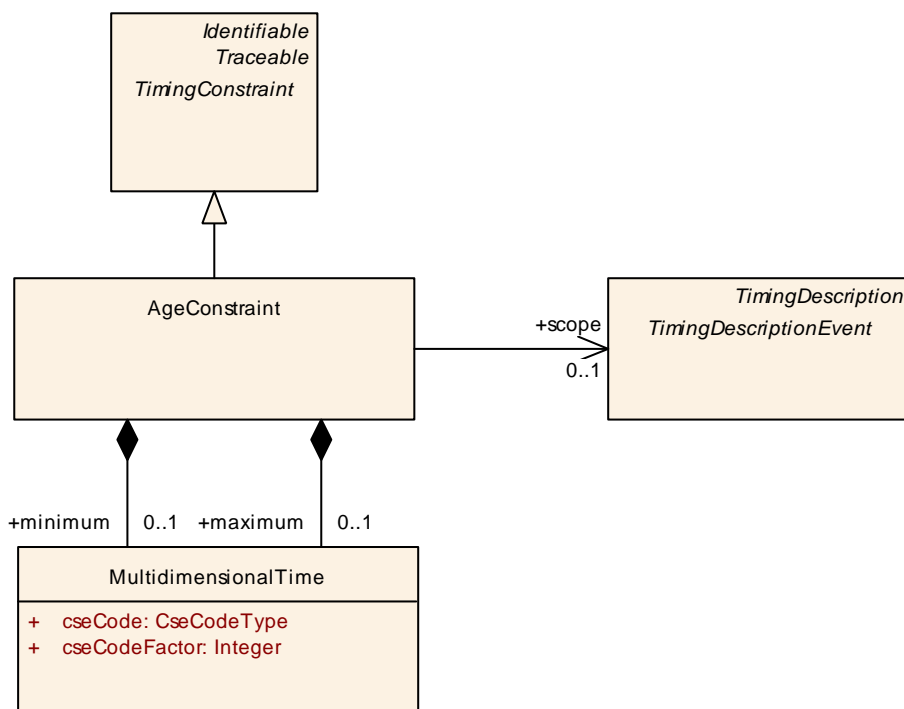

Figure 7.20: Age constraint

An *AgeConstraint* can define a minimum and maximum age for the *VariableDataPrototype* referenced by the *TDEventVariableDataPrototype* scope.

[constr_4573]{DRAFT} **Restricted usage of AgeConstraint** [An *AgeConstraint* shall only be defined for events of type *TimingDescriptionEvent* associated with the receipt and reading of data.](/)

Class	AgeConstraint			
Package	M2::AUTOSARTemplates::CommonStructure::Timing::TimingConstraint::AgeConstraint			
Note	The AgeConstraint is used to impose a constraint on an Timing Description Event referenced by the scope. A minimum and a maximum age can be specified.			
Base	ARObject, Identifiable, MultilanguageReferrable, Referrable, TimingConstraint , Traceable			
Attribute	Type	Mult.	Kind	Note
maximum	MultidimensionalTime	0..1	aggr	The maximum age.
minimum	MultidimensionalTime	0..1	aggr	The minimum age.
scope	TimingDescriptionEvent	0..1	ref	The scope of an AgeConstraint is any TimingDescription Event that indicates any receipt of data.

Table 7.11: AgeConstraint

7.4 SynchronizationTimingConstraint

The objective of synchronization in a distributed environment is to establish and maintain a consistent time base for the interaction between different subsystems, in order to obtain correct runtime order and avoid unexpected race conditions. While mechanisms to establish synchronization need to be provided at the implementation level, the necessity for synchronization needs to be expressed at design level. For this purpose, synchronization constraints are used.

[TPS_TIMEX_00074]{DRAFT} SynchronizationTimingConstraint specifies synchronicity constraints [The element [SynchronizationTimingConstraint](#) is used to specify a synchronization constraint among the occurrences of two or more timing description events.] ([RS_TIMEX_00001](#), [RS_TIMEX_00002](#), [RS_TIMEX_00007](#), [RS_TIMEX_00008](#), [RS_TIMEX_00017](#))

A [SynchronizationTimingConstraint](#) is imposed either on events ([7.4.2](#)) or on event chains ([7.4.1](#)).

Class	SynchronizationTimingConstraint
Package	M2::AUTOSARTemplates::CommonStructure::Timing::TimingConstraint::SynchronizationTimingConstraint
Note	This constraint is used to restrict the timing behavior of different, but correlated events or event chains, with regard to synchronization. Thereby, in case of imposing a synchronization timing constraint on events or event chains the following two scenarios are supported: 1) [synchronizationConstraintType=responseSynchronization] Events: An arbitrary number of correlated events which play the role of responses shall occur synchronously with respect to a predefined tolerance. Event Chains: An arbitrary number of correlated event chains with a common stimulus, but different responses, where the responses shall occur synchronously with respect to a predefined tolerance. 2) [synchronizationConstraintType=stimulusSynchronization] Events: An arbitrary number of correlated events which play the role of stimuli shall occur synchronously with respect to a predefined tolerance. Event Chains: An arbitrary number of correlated event chains with a common response, but different stimuli, where the stimuli shall occur synchronously with respect to a predefined tolerance.





Class	SynchronizationTimingConstraint			
	<p>In case of imposing a synchronization timing constraint on events the following two scenarios are supported:</p> <p>1) [eventOccurrenceKind=singleOccurrence] Any of the events shall occur only once in the given time interval.</p> <p>2) [eventOccurrenceKind=multipleOccurrences] Any of the events may occur more than once in the given time interval. In other words multiple occurrences of an event within the given time interval are permitted.</p>			
Base	<i>ARObject, Identifiable, MultilanguageReferrable, Referrable, TimingConstraint, Traceable</i>			
Attribute	Type	Mult.	Kind	Note
eventOccurrenceKind	EventOccurrenceKindEnum	0..1	attr	The specific occurrence kind of an event occurring within the given time interval.
scope	TimingDescriptionEventChain	*	ref	The event chains that are in the scope of the constraint.
scopeEvent	TimingDescriptionEvent	*	ref	The events that are in the scope of the constraint.
synchronizationConstraintType	SynchronizationTypeEnum	1	attr	The specific type of this synchronization constraint.
tolerance	MultidimensionalTime	1	aggr	The maximum time interval, within which the synchronized events shall occur.

Table 7.12: SynchronizationTimingConstraint

Enumeration	EventOccurrenceKindEnum
Package	M2::AUTOSARTemplates::CommonStructure::Timing::TimingConstraint::SynchronizationTimingConstraint
Note	This is used to describe the type of the occurrence of an event within a given time interval.
Literal	Description
multipleOccurrences	Specifies that an event may occur more than once in a given time interval. Tags: atp.EnumerationLiteralIndex=0
singleOccurrence	Specifies that an event shall occur only once in a given time interval. Tags: atp.EnumerationLiteralIndex=1

Table 7.13: EventOccurrenceKindEnum

Enumeration	SynchronizationTypeEnum
Package	M2::AUTOSARTemplates::CommonStructure::Timing::TimingConstraint::SynchronizationTimingConstraint
Note	This is used to describe the type of the synchronization timing constraint.
Literal	Description
responseSynchronization	<p>In case that the Synchronization Timing Constraint is specified for event chains, the response events of the associated event chains shall occur synchronously with respect to the specified tolerance. All associated event chains shall have the same stimulus event.</p> <p>In case that the Synchronization Timing Constraint is specified for events, the associated events shall occur synchronously with respect to the specified tolerance. All associated events represent the response events of a common stimulus event, even such a stimulus event is not known yet or not available in the scope of the model.</p> <p>Tags:atp.EnumerationLiteralIndex=0</p>





Enumeration	SynchronizationTypeEnum
stimulus Synchronization	In case that the Synchronization Timing Constraint is specified for event chains, the stimulus events of the associated event chains shall occur synchronously with respect to the specified tolerance. All associated event chains shall have the same response event. In case that the Synchronization Timing Constraint is specified for events, the associated events shall occur synchronously with respect to the specified tolerance. All associated events represent the stimulus events of a common response event, even such a response event is not known yet or not available in the scope of the model. Tags: atp.EnumerationLiteralIndex=1

Table 7.14: SynchronizationTypeEnum

[constr_4588]{DRAFT} **SynchronizationTimingConstraint** shall either reference events or event chains [The *SynchronizationTimingConstraint* shall either reference timing description events or timing description event chains, but not both at the same time.]()

7.4.1 SynchronizationTimingConstraint on Event Chains

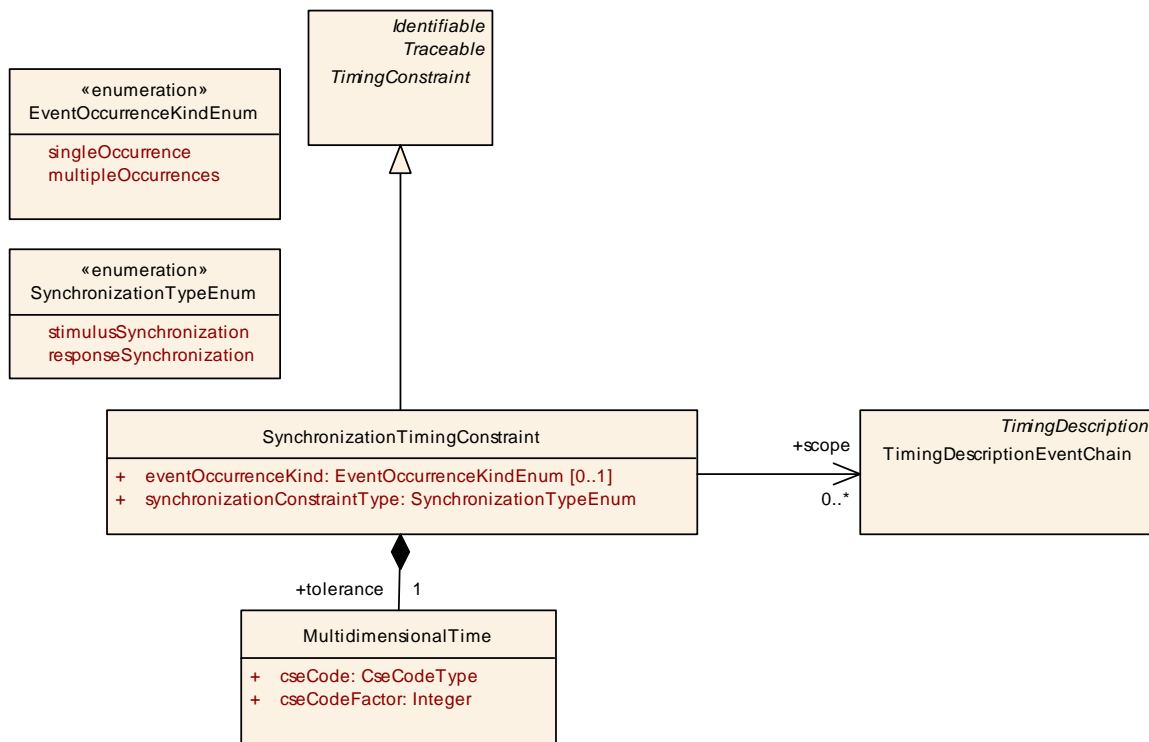

Figure 7.21: Synchronization Timing Constraint on Event Chains

The purpose of the *SynchronizationTimingConstraint* is to impose a synchronization constraint among either the stimulus or response event occurrences of two or more event chains. In the former case (stimulus synchronization) the referenced event chains shall have the same response event (join), or in the latter case (response synchronization) they shall have the same stimulus event (fork).

The `SynchronizationTimingConstraint` is characterized by the following parameters:

- Tolerance
- Event Occurrence Kind
- Synchronization Constraint Type

The parameters are described in the following and are illustrated in Figure 7.22 and Figure 7.23.

Tolerance The parameter `tolerance` specifies the time interval within which the referenced events shall occur synchronously. The events may occur in any order within this time interval. The time interval starts at the point-in-time when one of the referenced events occurs.

Event Occurrence Kind The optional parameter `eventOccurrenceKind` specifies whether the referenced events shall occur only once (single occurrence) or may occur multiple times (multiple occurrences) in the given time interval.

Synchronization Constraint Type The parameter `synchronizationConstraintType` specifies whether the `SynchronizationTimingConstraint` is imposed on the stimulus or response events of the referenced event chains.

[constr_4580]{DRAFT} `SynchronizationTimingConstraint` shall reference at least two event chains [In the case, that the `SynchronizationTimingConstraint` is imposed on event chains then at least two (2) timing description event chains shall be referenced.]()

[constr_4587]{DRAFT} **Specifying attribute `synchronizationConstraintType`** [The attribute `synchronizationConstraintType` shall be specified if the `SynchronizationTimingConstraint` is imposed on event chains.]()

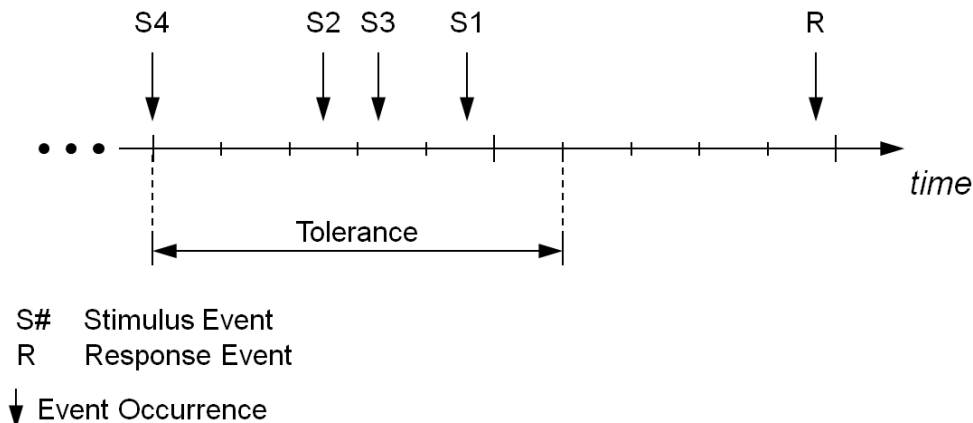

Figure 7.22: Parameters characterizing the Synchronization Timing Constraint imposed on the stimulus events of event chains.

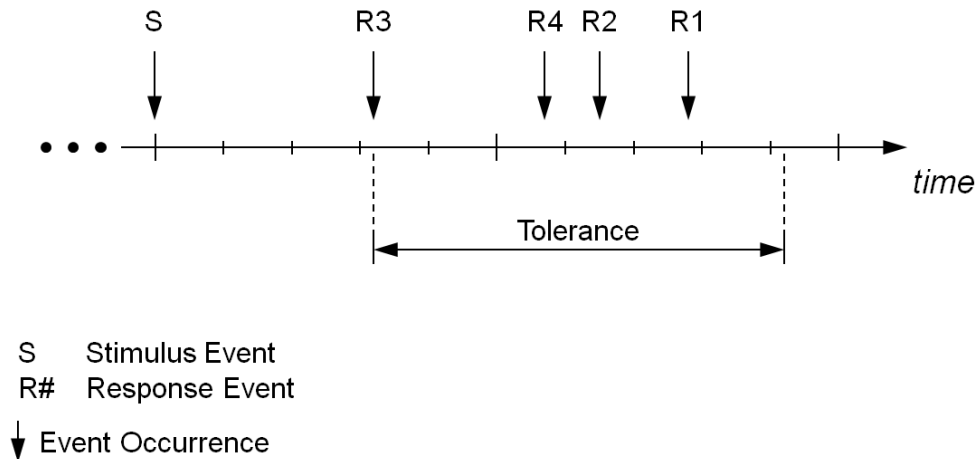

Figure 7.23: Parameters characterizing the Synchronization Timing Constraint imposed on the response events of event chains.

An example for synchronizing on *stimuli* of event chains would be an adaptive cruise control that expects data from different sensors, which shall be sampled (quasi) simultaneously with respect to a predefined tolerance.

An example for synchronizing on *responses* of event chains would be the blinking of different indicator lights, which shall occur (quasi) simultaneously with respect to a predefined tolerance.

7.4.2 SynchronizationTimingConstraint on Events

As mentioned above, the purpose of the [SynchronizationTimingConstraint](#) is to impose a synchronization constraint among either the stimulus or response event occurrences of two or more event chains. However, in some cases the complete event chains are not entirely known, or not available in the scope of the model, at the point in time the timing constraint shall be specified. For this purpose, the AUTOSAR Timing Extensions allow the specification of synchronization constraints on events. In this case, the events referenced by the constraint are related implicitly, because they have a common stimulus (in case of constraint type [responseSynchronization](#) or a common response (in case of constraint type [stimulusSynchronization](#) not known yet, or not available in the scope of the model.

At a later stage during the development, when the refined software architecture exposes the complete event chains (e.g. because the common stimulus gets known), the respective event chains shall be specified and associated with a [SynchronizationTimingConstraint](#) on event chains (see [7.4.1](#)) in order to refine the previously defined [SynchronizationTimingConstraint](#) on events.

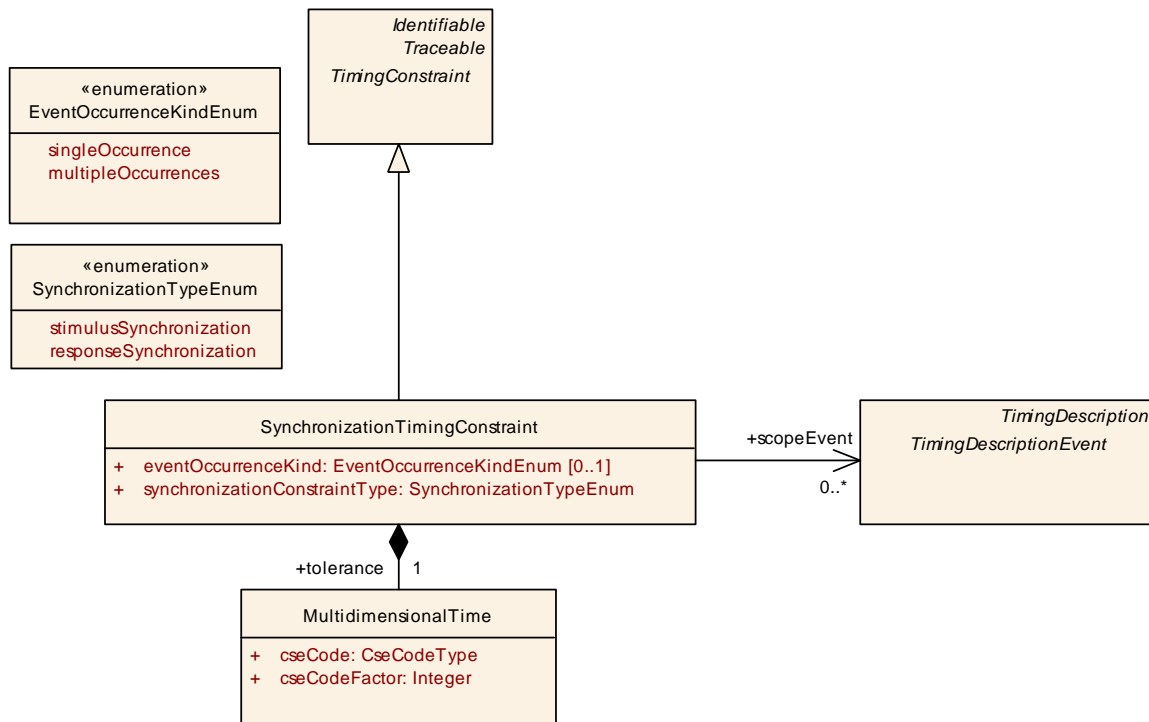

Figure 7.24: Synchronization Timing Constraint on Events

The purpose of the `SynchronizationTimingConstraint` is to impose a synchronization constraint among the occurrences of two or more events. The `SynchronizationTimingConstraint` is characterized by the following parameters:

- Tolerance
- Event Occurrence Kind
- Synchronization Constraint Type

The parameters are described in the following and are illustrated in Figure 7.25.

Tolerance The parameter `tolerance` specifies the time interval within which the referenced events shall occur synchronously. The events may occur in any order within this time interval. The time interval starts at the point-in-time when one of the referenced events occurs.

Event Occurrence Kind The parameter `eventOccurrenceKind` specifies whether the referenced events shall occur only once (single occurrence) or may occur multiple times (multiple occurrences) in the given time interval.

Synchronization Constraint Type The parameter `synchronizationConstraintType` specifies whether the associated events of the `SynchronizationTimingConstraint` have a common stimulus or response.

[constr_4579]{DRAFT} **`SynchronizationTimingConstraint` shall reference at least two events** [In the case, that the `SynchronizationTimingConstraint` is imposed on events then at least two (2) timing description events shall be referenced.]
()

[constr_4586]{DRAFT} Specifying attribute `synchronizationConstraintType`
 [The attribute `synchronizationConstraintType` shall be specified if the `SynchronizationTimingConstraint` is imposed on events.]()

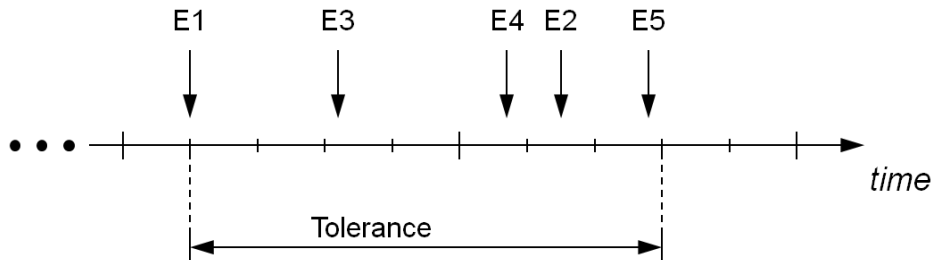

E# Event #

↓ Event Occurrence

Figure 7.25: Parameter characterizing the Synchronization Constraint

7.5 OffsetTimingConstraint

[TPS_TIMEX_00081]{DRAFT} `OffsetTimingConstraint` specifies offset between occurrences of events [The element `OffsetTimingConstraint` is used to specify an offset between the occurrences of two timing description events.] ([RS_TIMEX_00001](#), [RS_TIMEX_00002](#), [RS_TIMEX_00008](#))

An `OffsetTimingConstraint` bounds the time offset between the occurrence of two timing events, without requiring a direct functional dependency between the source and the target.

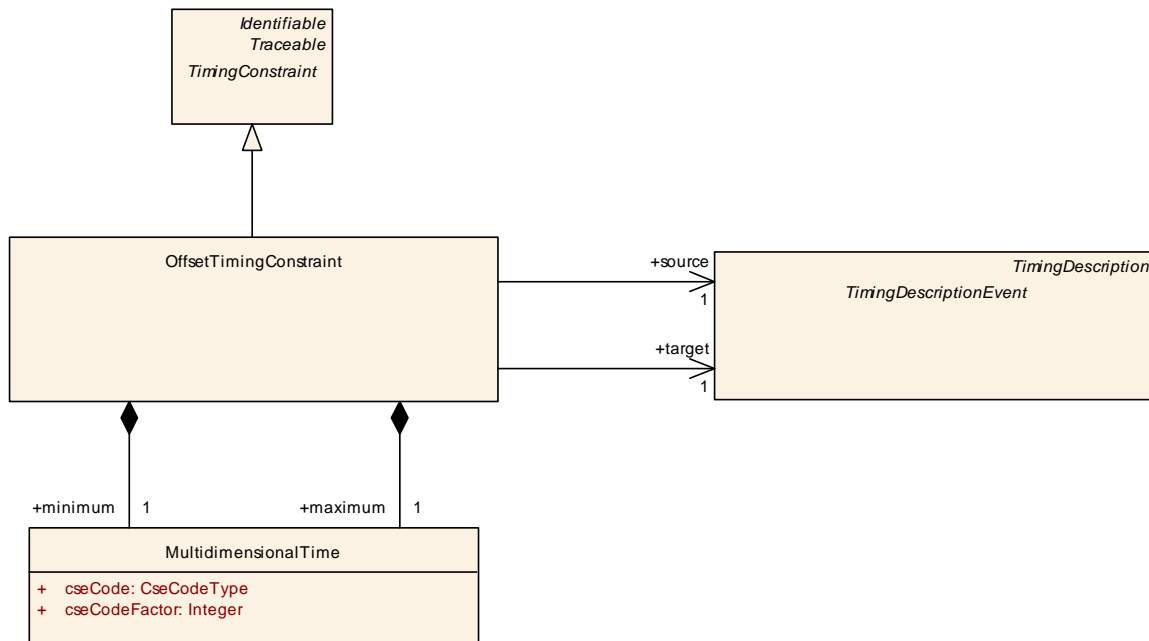

Figure 7.26: Offset Timing Constraint

Class	OffsetTimingConstraint			
Package	M2::AUTOSARTemplates::CommonStructure::Timing::TimingConstraint::OffsetConstraint			
Note	<p>Bounds the time offset between the occurrence of two timing events, without requiring a direct functional dependency between the source and the target.</p> <p>If the target event occurs, it is expected to occur earliest with the minimum, and latest with the maximum offset relatively after the occurrence of the source event. Note: not every source event occurrence shall be followed by a target event occurrence.</p> <p>In contrast to LatencyTimingConstraint, there shall not necessarily be a causal dependency between the source and target event.</p>			
Base	ARObject, Identifiable, MultilanguageReferrable, Referrable, TimingConstraint , Traceable			
Attribute	Type	Mult.	Kind	Note
maximum	MultidimensionalTime	1	aggr	The maximum offset the target event occurs relatively after the occurrence of the source event. Tags: xml.sequenceOffset=20
minimum	MultidimensionalTime	1	aggr	The minimum offset the target event occurs relatively after the occurrence of the source event. Tags: xml.sequenceOffset=10
source	TimingDescriptionEvent	1	ref	The timing event that the target event is to be synchronized with.
target	TimingDescriptionEvent	1	ref	The timing event which is expected to occur timely after the source event.

Table 7.15: OffsetTimingConstraint

A Constraint History

A.1 Constraint and Specification Item History of this document according to AUTOSAR Release 20-11

A.1.1 Added Traceables in R20-11

Number	Heading
[TPS_TIMEX_00001]	Purpose of TimingDescriptionEvent
[TPS_TIMEX_00002]	Purpose of TimingDescriptionEventChain
[TPS_TIMEX_00003]	EventTriggeringConstraint specifies occurrence behavior respectively model
[TPS_TIMEX_00004]	LatencyTimingConstraint specifies latency constraints
[TPS_TIMEX_00005]	AgeConstraint to specify age constraints
[TPS_TIMEX_00006]	SynchronizationTimingConstraint specifies synchronicity constraints
[TPS_TIMEX_00009]	Optional use of timing extensions
[TPS_TIMEX_00010]	PeriodicEventTriggering specifies periodic occurrences of events
[TPS_TIMEX_00011]	SporadicEventTriggering specifies sporadic occurrences of events
[TPS_TIMEX_00012]	ConcretePatternEventTriggering specifies concrete pattern of occurrences of events
[TPS_TIMEX_00013]	BurstPatternEventTriggering specifies burst of occurrences of events
[TPS_TIMEX_00014]	ArbitraryEventTriggering specifies arbitrary occurrences of an event
[TPS_TIMEX_00015]	OffsetTimingConstraint specifies offset between occurrences of events
[TPS_TIMEX_00016]	Purpose of TDEventVfb
[TPS_TIMEX_00017]	TDEventVariableDataPrototype specifies events observable at sender/receiver ports
[TPS_TIMEX_00018]	TDEventOperation specifies events observable at client/server ports.
[TPS_TIMEX_00019]	TDEventModeDeclaration specifies events observable at mode ports.
[TPS_TIMEX_00027]	Purpose of TDEventComplex
[TPS_TIMEX_00032]	Purpose of VfbTiming
[TPS_TIMEX_00034]	Purpose of SystemTiming
[TPS_TIMEX_00037]	TimingConstraint is a Traceable
[TPS_TIMEX_00039]	TDEventTrigger specifies events observable at trigger ports
[TPS_TIMEX_00040]	Blueprinting VfbTiming
[TPS_TIMEX_00042]	Purpose of TDEventVfbPort
[TPS_TIMEX_00043]	Purpose of TDEventVfbReference
[TPS_TIMEX_00058]	Purpose of TDEventServiceInstance
[TPS_TIMEX_00059]	Purpose of TDEventServiceInstanceEvent
[TPS_TIMEX_00060]	Purpose of TDEventServiceInstanceField
[TPS_TIMEX_00061]	Purpose of TDEventServiceInstanceMethod





Number	Heading
[TPS_TIMEX_00062]	Purpose of TDEventServiceInstanceDiscovery
[TPS_TIMEX_00063]	Purpose of MachineTiming
[TPS_TIMEX_00064]	Purpose of ExecutableTiming
[TPS_TIMEX_00065]	Purpose of ServiceTiming

Table A.1: Added Traceables in R20-11

A.1.2 Changed Traceables in R20-11

none

A.1.3 Deleted Traceables in R20-11

none

A.1.4 Added Constraints in R20-11

Number	Heading
[constr_4500]	Restricted usage of functions
[constr_4501]	Application rule for the occurrence expression in TDEventComplex
[constr_4502]	Use references only as function operands
[constr_4503]	Restricted usage of AutosarOperationArgumentInstance for Content Filter
[constr_4504]	Restricted usage of AgeConstraint
[constr_4505]	Specifying minimum and maximum number of occurrences
[constr_4506]	Specifying minimum inter-arrival time and pattern length
[constr_4507]	Specifying pattern length, pattern jitter and patter period
[constr_4508]	TDEventVfb shall reference PortPrototypeBlueprint only in Blueprints
[constr_4509]	Only VfbTiming shall be a Blueprint
[constr_4513]	SynchronizationTimingConstraint shall reference at least two events
[constr_4514]	SynchronizationTimingConstraint shall reference at least two event chains
[constr_4515]	Specifying stimulus and response in TimingDescriptionEventChain
[constr_4516]	Specifying event chain segments
[constr_4517]	Referencing no further event chain segments
[constr_4518]	Specifying stimulus event and response event of first and last event chain segment
[constr_4519]	Specifying patternLength
[constr_4520]	Specifying attribute synchronizationConstraintType





Number	Heading
[constr_4521]	Specifying attribute synchronizationConstraintType
[constr_4522]	SynchronizationTimingConstraint shall either reference events or event chains
[constr_4543]	Maximum value of the parameter minimumInterArrivalTime
[constr_4544]	Specifying patternLength , patternJitter and patternPeriod
[constr_4551]	Use only Numericals in TDEventOccurrenceExpression
[constr_4552]	Restricted usage of AutosarVariableInstance for Content Filter

Table A.2: Added Constraints in R20-11

A.1.5 Changed Constraints in R20-11

none

A.1.6 Deleted Constraints in R20-11

none

A.2 Constraint and Specification Item History of this document according to AUTOSAR Release 21-11

A.2.1 Added Traceables in R21-11

Number	Heading
[TPS_TIMEX_00069]	Purpose of TimingDescriptionEvent
[TPS_TIMEX_00070]	Purpose of TimingDescriptionEventChain
[TPS_TIMEX_00071]	EventTriggeringConstraint specifies occurrence behavior respectively model
[TPS_TIMEX_00072]	LatencyTimingConstraint specifies latency constraints
[TPS_TIMEX_00073]	AgeConstraint to specify age constraints
[TPS_TIMEX_00074]	SynchronizationTimingConstraint specifies synchronicity constraints
[TPS_TIMEX_00075]	Optional use of timing extensions
[TPS_TIMEX_00076]	PeriodicEventTriggering specifies periodic occurrences of events
[TPS_TIMEX_00077]	SporadicEventTriggering specifies sporadic occurrences of events
[TPS_TIMEX_00078]	ConcretePatternEventTriggering specifies concrete pattern of occurrences of events





Number	Heading
[TPS_TIMEX_00079]	BurstPatternEventTriggering specifies burst of occurrences of events
[TPS_TIMEX_00080]	ArbitraryEventTriggering specifies arbitrary occurrences of an event
[TPS_TIMEX_00081]	OffsetTimingConstraint specifies offset between occurrences of events
[TPS_TIMEX_00082]	Purpose of TDEventVfb
[TPS_TIMEX_00083]	TDEventVariableDataPrototype specifies events observable at sender/receiver ports
[TPS_TIMEX_00084]	TDEventOperation specifies events observable at client/server ports.
[TPS_TIMEX_00085]	TDEventModeDeclaration specifies events observable at mode ports.
[TPS_TIMEX_00086]	Purpose of TDEventComplex
[TPS_TIMEX_00087]	Purpose of VfbTiming
[TPS_TIMEX_00088]	Purpose of SystemTiming
[TPS_TIMEX_00089]	TimingConstraint is a Traceable
[TPS_TIMEX_00090]	TDEventTrigger specifies events observable at trigger ports
[TPS_TIMEX_00091]	Blueprinting VfbTiming
[TPS_TIMEX_00092]	Purpose of TDEventVfbPort
[TPS_TIMEX_00093]	Purpose of TDEventVfbReference

Table A.3: Added Traceables in R21-11

A.2.2 Changed Traceables in R21-11

none

A.2.3 Deleted Traceables in R21-11

Number	Heading
[TPS_TIMEX_00001]	Purpose of TimingDescriptionEvent
[TPS_TIMEX_00002]	Purpose of TimingDescriptionEventChain
[TPS_TIMEX_00003]	EventTriggeringConstraint specifies occurrence behavior respectively model
[TPS_TIMEX_00004]	LatencyTimingConstraint specifies latency constraints
[TPS_TIMEX_00005]	AgeConstraint to specify age constraints
[TPS_TIMEX_00006]	SynchronizationTimingConstraint specifies synchronicity constraints
[TPS_TIMEX_00009]	Optional use of timing extensions
[TPS_TIMEX_00010]	PeriodicEventTriggering specifies periodic occurrences of events
[TPS_TIMEX_00011]	SporadicEventTriggering specifies sporadic occurrences of events





Number	Heading
[TPS_TIMEX_00012]	ConcretePatternEventTriggering specifies concrete pattern of occurrences of events
[TPS_TIMEX_00013]	BurstPatternEventTriggering specifies burst of occurrences of events
[TPS_TIMEX_00014]	ArbitraryEventTriggering specifies arbitrary occurrences of an event
[TPS_TIMEX_00015]	OffsetTimingConstraint specifies offset between occurrences of events
[TPS_TIMEX_00016]	Purpose of TDEventVfb
[TPS_TIMEX_00017]	TDEventVariableDataPrototype specifies events observable at sender/receiver ports
[TPS_TIMEX_00018]	TDEventOperation specifies events observable at client/server ports.
[TPS_TIMEX_00019]	TDEventModeDeclaration specifies events observable at mode ports.
[TPS_TIMEX_00027]	Purpose of TDEventComplex
[TPS_TIMEX_00032]	Purpose of VfbTiming
[TPS_TIMEX_00034]	Purpose of SystemTiming
[TPS_TIMEX_00037]	TimingConstraint is a Traceable
[TPS_TIMEX_00039]	TDEventTrigger specifies events observable at trigger ports
[TPS_TIMEX_00040]	Blueprinting VfbTiming
[TPS_TIMEX_00042]	Purpose of TDEventVfbPort
[TPS_TIMEX_00043]	Purpose of TDEventVfbReference

Table A.4: Deleted Traceables in R21-11

A.2.4 Added Constraints in R21-11

Number	Heading
[constr_4569]	Restricted usage of functions
[constr_4570]	Application rule for the occurrence expression in TDEventComplex
[constr_4571]	Use references only as function operands
[constr_4572]	Restricted usage of AutosarOperationArgumentInstance for Content Filter
[constr_4573]	Restricted usage of AgeConstraint
[constr_4574]	Specifying minimum and maximum number of occurrences
[constr_4575]	Specifying minimum inter-arrival time and pattern length
[constr_4576]	Specifying pattern length, pattern jitter and patten period
[constr_4577]	TDEventVfb shall reference PortPrototypeBlueprint only in Blueprints
[constr_4578]	Only VfbTiming shall be a Blueprint
[constr_4579]	SynchronizationTimingConstraint shall reference at least two events
[constr_4580]	SynchronizationTimingConstraint shall reference at least two event chains
[constr_4581]	Specifying stimulus and response in TimingDescriptionEventChain
[constr_4582]	Specifying event chain segments





Number	Heading
[constr_4583]	Referencing no further event chain segments
[constr_4584]	Specifying <i>stimulus</i> event and <i>response</i> event of first and last event chain segment
[constr_4585]	Specifying <i>patternLength</i>
[constr_4586]	Specifying attribute <i>synchronizationConstraintType</i>
[constr_4587]	Specifying attribute <i>synchronizationConstraintType</i>
[constr_4588]	<i>SynchronizationTimingConstraint</i> shall either reference events or event chains
[constr_4589]	Maximum value of the parameter <i>minimumInterArrivalTime</i>
[constr_4590]	Specifying <i>patternLength</i> , <i>patternJitter</i> and <i>patternPeriod</i>
[constr_4591]	Use only Numericals in <i>TDEventOccurrenceExpression</i>
[constr_4592]	Restricted usage of <i>AutosarVariableInstance</i> for Content Filter

Table A.5: Added Constraints in R21-11

A.2.5 Changed Constraints in R21-11

none

A.2.6 Deleted Constraints in R21-11

Number	Heading
[constr_4500]	Restricted usage of functions
[constr_4501]	Application rule for the occurrence expression in <i>TDEventComplex</i>
[constr_4502]	Use references only as function operands
[constr_4503]	Restricted usage of <i>AutosarOperationArgumentInstance</i> for Content Filter
[constr_4504]	Restricted usage of <i>AgeConstraint</i>
[constr_4505]	Specifying minimum and maximum number of occurrences
[constr_4506]	Specifying minimum inter-arrival time and pattern length
[constr_4507]	Specifying pattern length, pattern jitter and patter period
[constr_4508]	<i>TDEventVfb</i> shall reference <i>PortPrototypeBlueprint</i> only in Blueprints
[constr_4509]	Only <i>VfbTiming</i> shall be a Blueprint
[constr_4513]	<i>SynchronizationTimingConstraint</i> shall reference at least two events
[constr_4514]	<i>SynchronizationTimingConstraint</i> shall reference at least two event chains
[constr_4515]	Specifying stimulus and response in <i>TimingDescriptionEventChain</i>
[constr_4516]	Specifying event chain segments
[constr_4517]	Referencing no further event chain segments





Number	Heading
[constr_4518]	Specifying stimulus event and response event of first and last event chain segment
[constr_4519]	Specifying patternLength
[constr_4520]	Specifying attribute synchronizationConstraintType
[constr_4521]	Specifying attribute synchronizationConstraintType
[constr_4522]	SynchronizationTimingConstraint shall either reference events or event chains
[constr_4543]	Maximum value of the parameter minimumInterArrivalTime
[constr_4544]	Specifying patternLength , patternJitter and patternPeriod
[constr_4551]	Use only Numericals in TDEventOccurrenceExpression
[constr_4552]	Restricted usage of AutosarVariableInstance for Content Filter

Table A.6: Deleted Constraints in R21-11

B Mentioned Class Tables

For the sake of completeness, this chapter contains a set of class tables representing meta-classes mentioned in the context of this document but which are not contained directly in the scope of describing specific meta-model semantics.

Class	ARElement (abstract)
Package	M2::AUTOSARTemplates::GenericStructure::GeneralTemplateClasses::ARPackage
Note	An element that can be defined stand-alone, i.e. without being part of another element (except for packages of course).
Base	<i>ARObject, CollectableElement, Identifiable, MultilanguageReferrable, PackageableElement, Referrable</i>
Subclasses	<i>AbstractIamRemoteSubject, AclObjectSet, AclOperation, AclPermission, AclRole, AliasNameSet, Allocator, ApApplicationError, ApApplicationErrorDomain, ApApplicationErrorSet, AutosarDataType, BaseType, BlueprintMappingSet, BuildActionManifest, CalibrationParameterValueSet, ClientIdDefinitionSet, Collection, CompositionPortToExecutablePortMapping, CompuMethod, ConsistencyNeedsBlueprintSet, ConstantSpecification, ConstantSpecificationMappingSet, CryptoEllipticCurveProps, CryptoServiceCertificate, CryptoServiceKey, CryptoServicePrimitive, CryptoServiceQueue, CryptoSignatureScheme, DataConstr, DataExchangePoint, DataTransformationSet, DataTypeMappingSet, DiagnosticCommonElement, DiagnosticConnection, DiagnosticContributionSet, DltContext, DltEcu, Documentation, E2EProfileCompatibilityProps, E2EProfileConfigurationSet, EndToEndProtectionSet, EthIpProps, EthTcplpIcmpProps, EthTcplpProps, EvaluatedVariantSet, Executable, FMFeature, FMFeatureMap, FMFeatureModel, FMFeatureSelectionSet, FunctionGroupSet, GeneralPurposeConnection, Grant, GrantDesign, HwCategory, HwElement, HwType, IPsecConfigProps, IdsCommonElement, IdsDesign, InterfaceMapping, InterpolationRoutineMappingSet, KeywordSet, LifeCycleInfoSet, LifeCycleStateDefinitionGroup, LogAndTraceMessageCollectionSet, Machine, McFunction, McGroup, ModeDeclarationGroup, ModeDeclarationMappingSet, PhmContributionToMachineMapping, PhysicalDimension, PhysicalDimensionMappingSet, PlatformModuleEndpointConfiguration, PortInterface, PortInterfaceMappingSet, PortInterfaceToDataTypeMapping, PortPrototypeBlueprint, PostBuildVariantCriterion, PostBuildVariantCriterionValueSet, PredefinedVariant, ProcessDesign, ProcessDesignToMachineDesignMapping, RapidPrototypingScenario, SdgDef, SecureComProps, SecurityEventReportToSecurityEventDefinitionMapping, ServiceInstanceToSignalMapping, ServiceInstanceToSwClusterDesignPortPrototypeMapping, ServiceInterfaceElementMapping, ServiceInterfacePedigree, SignalServiceTranslationPropsSet, SoftwareCluster, SoftwareClusterDesign, SoftwarePackage, SomeipDataPrototypeTransformationProps, SomeipSdClientEventGroupTimingConfig, SomeipSdClientServiceInstanceConfig, SomeipSdServer</i>





Class	ARElement (abstract)			
	<p style="text-align: center;">△</p> <p>EventGroupTimingConfig, SomeIpSdServerServiceInstanceConfig, StartupConfig, SwAddrMethod, Sw AxisType, SwComponentType, SwRecordLayout, SwSystemconst, SwSystemconstantValueSet, System, SystemSignal, SystemSignalGroup, TimingExtension, TlsConnectionGroup, TlvDataIdDefinitionSet, TransformationPropsSet, TransformationPropsToServiceInterfaceElementMapping, Unit, UnitGroup, UploadablePackageElement, VehiclePackage, ViewMapSet</p>			
Attribute	Type	Mult.	Kind	Note
–	–	–	–	–

Table B.1: ARElement

Class	AdaptiveApplicationSwComponentType			
Package	M2::AUTOSARTemplates::AdaptivePlatform::ApplicationDesign::ApplicationStructure			
Note	<p>This meta-class represents the ability to support the formal modeling of application software on the AUTOSAR adaptive platform. Consequently, it shall only be used on the AUTOSAR adaptive platform.</p> <p>Tags: atp.Status=draft atp.recommendedPackage=AdaptiveApplicationSwComponentTypes</p>			
Base	ARElement , AObject , AtpBlueprint , AtpBlueprintable , AtpClassifier , AtpType , CollectableElement , Identifiable , MultilanguageReferrable , PackageableElement , Referrable , SwComponentType			
Attribute	Type	Mult.	Kind	Note
internalBehavior	AdaptiveSwcInternal Behavior	0..1	aggr	<p>This aggregation represents the internal behavior of the AdaptiveApplicationSwComponentType for the AUTOSAR adaptive platform.</p> <p>Stereotypes: atpSplitable; atpVariation Tags: atp.Splitkey=internalBehavior.shortName, internalBehavior.variationPoint.shortLabel atp.Status=draft vh.latestBindingTime=preCompileTime</p>

Table B.2: AdaptiveApplicationSwComponentType

Class	AdaptivePlatformServiceInstance (abstract)			
Package	M2::AUTOSARTemplates::AdaptivePlatform::ServiceInstanceManifest::ServiceInstanceDeployment			
Note	<p>This meta-class represents the ability to describe the existence and configuration of a service instance in an abstract way.</p> <p>Tags:atp.Status=draft</p>			
Base	ARElement , AObject , CollectableElement , Identifiable , MultilanguageReferrable , PackageableElement , Referrable , UploadablePackageElement			
Subclasses	ProvidedApServiceInstance , RequiredApServiceInstance			
Attribute	Type	Mult.	Kind	Note
e2eEvent ProtectionProps	End2EndEvent ProtectionProps	*	aggr	<p>This aggregation allows to protect an event or a field notifier that is defined inside of the ServiceInterface that is referenced by the ServiceInstance in the role service interface.</p> <p>Tags:atp.Status=draft</p>
e2eMethod ProtectionProps	End2EndMethod ProtectionProps	*	aggr	<p>This aggregation allows to protect a method or a field getter or a field setter that is defined inside of the ServiceInterface that is referenced by the ServiceInstance in the role serviceInterface</p> <p>Tags:atp.Status=draft</p>





Class		AdaptivePlatformServiceInstance (abstract)		
secureCom Config	ServiceInterface ElementSecureCom Config	*	aggr	Configuration settings to secure the communication of ServiceInterface elements. Tags: atp.Status=draft
serviceInterface Deployment	ServiceInterface Deployment	0..1	ref	Reference to a ServiceInterfaceDeployment that identifies the ServiceInterface that is represented by the Service Instance. Tags: atp.Status=draft

Table B.3: AdaptivePlatformServiceInstance

Class		AdaptiveSwcInternalBehavior		
Package		M2::AUTOSARTemplates::AdaptivePlatform::ApplicationDesign::AdaptiveInternalBehavior		
Note		This meta-class represents the ability to define an internal behavior of an AtomicSwComponentType used on the AUTOSAR adaptive platform. Please note that the model of internal behavior in this case, in stark contrast to the situation of the AUTOSAR classic platform, is very minimal. Tags: atp.Status=draft		
Base		<i>ARObject, Identifiable, MultilanguageReferrable, Referrable</i>		
Attribute	Type	Mult.	Kind	Note
service Dependency	SwcService Dependency	*	aggr	This represents the collection of SwcService Dependencys owned by AdaptiveInternalBehavior. Tags: atp.Status=draft

Table B.4: AdaptiveSwcInternalBehavior

Primitive	Boolean	
Package		M2::AUTOSARTemplates::GenericStructure::GeneralTemplateClasses::PrimitiveTypes
Note		A Boolean value denotes a logical condition that is either 'true' or 'false'. It can be one of "0", "1", "true", "false" Tags: xml.xsd.customType=BOOLEAN xml.xsd.pattern=0 1 true false xml.xsd.type=string

Table B.5: Boolean

Class		ClientServerOperation		
Package		M2::AUTOSARTemplates::SWComponentTemplate::PortInterface		
Note		An operation declared within the scope of a client/server interface.		
Base		<i>ARObject, AtpClassifier, AtpFeature, AtpStructureElement, Identifiable, MultilanguageReferrable, Referrable</i>		
Attribute	Type	Mult.	Kind	Note
argument (ordered)	ArgumentDataPrototype	*	aggr	An argument of this ClientServerOperation Stereotypes: atpVariation Tags: vh.latestBindingTime=blueprintDerivationTime
fireAndForget	Boolean	0..1	attr	This attribute defines whether this method is a fire&forget method (true) or not (false). Tags: atp.Status=draft





Class	ClientServerOperation			
possibleApError	ApApplicationError	*	ref	This reference identifies AdaptivePlatformApplication Errors as a possible error raised by the enclosing Client ServerOperation. Tags: atp.Status=draft
possibleApError Set	ApApplicationErrorSet	*	ref	This reference represents the ability to refer to an entire group of ApApplicationErrors as one model element instead of having to refer to all the represented Ap ApplicationErrors separately. Tags: atp.Status=draft

Table B.6: ClientServerOperation

Class	CompositionSwComponentType			
Package	M2::AUTOSARTemplates::SWComponentTemplate::Composition			
Note	A CompositionSwComponentType aggregates SwComponentPrototypes (that in turn are typed by Sw ComponentTypes) as well as SwConnectors for primarily connecting SwComponentPrototypes among each others and towards the surface of the CompositionSwComponentType. By this means, hierarchical structures of software-components can be created. Tags: atp.recommendedPackage=SwComponentTypes			
Base	ARElement , ARObject , AtpBlueprint , AtpBlueprintable , AtpClassifier , AtpType , CollectableElement , Identifiable , MultilanguageReferrable , PackageableElement , Referrable , SwComponentType			
Attribute	Type	Mult.	Kind	Note
component	SwComponent Prototype	*	aggr	The instantiated components that are part of this composition. Stereotypes: atpSplitable; atpVariation Tags: atp.Splitkey=component.shortName, component.variation Point.shortLabel vh.latestBindingTime=postBuild
connector	SwConnector	*	aggr	SwConnectors have the principal ability to establish a connection among PortPrototypes. They can have many roles in the context of a CompositionSwComponentType. Details are refined by subclasses. The aggregation of SwConnectors is subject to variability with the purpose to support variant data flow. The aggregation is marked as atpSplitable in order to allow the extension of the ECU extract with AssemblySw Connectors between ApplicationSwComponentTypes and ServiceSwComponentTypes during the ECU integration. Stereotypes: atpSplitable; atpVariation Tags: atp.Splitkey=connector.shortName, connector.variation Point.shortLabel vh.latestBindingTime=postBuild
constantValue Mapping	ConstantSpecification MappingSet	*	ref	Reference to the ConstantSpecificationMapping to be applied for initValues of PPortComSpecs and RPortCom Spec. Stereotypes: atpSplitable Tags: atp.Splitkey=constantValueMapping
dataType Mapping	DataTypeMappingSet	*	ref	Reference to the DataTypeMapping to be applied for the used ApplicationDataTypes in ServiceInterfaces. Stereotypes: atpSplitable Tags: atp.Splitkey=dataTypeMapping

Table B.7: CompositionSwComponentType

Class	Executable			
Package	M2::AUTOSARTemplates::AdaptivePlatform::ApplicationDesign::ApplicationStructure			
Note	<p>This meta-class represents an executable program.</p> <p>Tags: atp.Status=draft atp.recommendedPackage=Executables</p>			
Base	ARElement , ARObject , AtpClassifier , CollectableElement , Identifiable , MultilanguageReferrable , PackageableElement , Referrable			
Attribute	Type	Mult.	Kind	Note
buildType	BuildTypeEnum	0..1	attr	<p>This attribute describes the buildType of a module and/or platform implementation.</p> <p>Tags:atp.Status=draft</p>
loggingBehavior	LoggingBehaviorEnum	0..1	attr	<p>This attribute indicates the intended logging behavior of the enclosing Executable.</p> <p>Tags:atp.Status=draft</p>
minimumTimer Granularity	TimeValue	0..1	attr	<p>This attribute describes the minimum timer resolution (TimeValue of one tick) that is required by the Executable.</p> <p>Tags:atp.Status=draft</p>
reporting Behavior	ExecutionState ReportingBehavior Enum	0..1	attr	<p>this attribute controls the execution state reporting behavior of the enclosing Executable.</p> <p>Tags:atp.Status=draft</p>
rootSw Component Prototype	RootSwComponent Prototype	0..1	aggr	<p>This represents the root SwCompositionPrototype of the Executable. This aggregation is required (in contrast to a direct reference of a SwComponentType) in order to support the definition of instanceRefs in Executable context.</p> <p>Tags:atp.Status=draft</p>
version	StrongRevisionLabel String	0..1	attr	<p>Version of the executable.</p> <p>Tags:atp.Status=draft</p>

Table B.8: Executable

Class	ExecutableTiming			
Package	M2::AUTOSARTemplates::CommonStructure::Timing::TimingAdaptivePlatform			
Note	<p>This meta-class represents the timing view for one or more executables.</p> <p>Tags: atp.Status=draft atp.recommendedPackage=TimingExtensions</p>			
Base	ARElement , ARObject , CollectableElement , Identifiable , MultilanguageReferrable , PackageableElement , Referrable , TimingExtension			
Attribute	Type	Mult.	Kind	Note
executable	Executable	1..*	ref	<p>This defines the scope of a ExecutableTiming. All corresponding timing descriptions and constraints shall be defined within this scope.</p> <p>Tags:atp.Status=draft</p>

Table B.9: ExecutableTiming

Primitive	Float
Package	M2::AUTOSARTemplates::GenericStructure::GeneralTemplateClasses::PrimitiveTypes
Note	An instance of Float is an element from the set of real numbers. Tags: xml.xsd.customType=FLOAT xml.xsd.type=double

Table B.10: Float

Class	<<atpMixedString>> FormulaExpression (abstract)			
Package	M2::AUTOSARTemplates::GenericStructure::FormulaLanguage			
Note	This class represents the syntax of the formula language. The class is modeled as an abstract class in order to be specialized into particular use cases. For each use case the referable objects might be specified in the specialization.			
Base	ARObject			
Subclasses	CompuGenericMath, FMFormulaByFeaturesAndAttributes, SwSystemconstDependentFormula, TDEventOccurrenceExpressionFormula, TimingConditionFormula			
Attribute	Type	Mult.	Kind	Note
atpReference	Referrable	*	ref	The referable object shall yield a numerical / boolean value. Stereotypes: atpAbstract
atpStringReference	Referrable	*	ref	The referable object shall yield a string value. Stereotypes: atpAbstract

Table B.11: FormulaExpression

Class	Machine			
Package	M2::AUTOSARTemplates::AdaptivePlatform::MachineManifest			
Note	Machine that represents an Adaptive Autosar Software Stack. Tags: atp.Status=draft atp.recommendedPackage=Machines			
Base	ARElement, ARObject, AtpClassifier, AtpFeature, AtpStructureElement, CollectableElement, Identifiable, MultilanguageReferrable, PackageableElement, Referrable			
Attribute	Type	Mult.	Kind	Note
defaultApplicationTimeout	EnterExitTimeout	0..1	aggr	This aggregation defines a default timeout in the context of a given Machine with respect to the launching and termination of applications. Tags: atp.Status=draft
environmentVariable	TagWithOptionalValue	*	aggr	This aggregation represents the collection of environment variables that shall be added to the environment defined on the level of the enclosing Machine. Stereotypes: atpSplitable Tags: atp.Splitkey=environmentVariable, environmentVariable.variationPoint.shortLabel atp.Status=draft
machineDesign	MachineDesign	1	ref	Reference to the MachineDesign this Machine is implementing. Tags: atp.Status=draft





Class	Machine			
module Instantiation	AdaptiveModule Instantiation	*	aggr	Configuration of Adaptive Autosar module instances that are running on the machine. Stereotypes: atpSplitable Tags: atp.Splitkey=moduleInstantiation.shortName atp.Status=draft
processor	Processor	1..*	aggr	This represents the collection of processors owned by the enclosing machine. Tags: atp.Status=draft
secure Communication Deployment	SecureCommunication Deployment	*	aggr	Deployment of secure communication protocol configuration settings to crypto module entities. Stereotypes: atpSplitable Tags: atp.Splitkey=secureCommunicationDeployment.short Name atp.Status=draft
trustedPlatform Executable LaunchBehavior	TrustedPlatform ExecutableLaunch BehaviorEnum	1	attr	This attribute controls the behavior of how authentication affects the ability to launch for each Executable. Tags: atp.Status=draft

Table B.12: Machine

Class	MachineTiming			
Package	M2::AUTOSARTemplates::CommonStructure::Timing::TimingAdaptivePlatform			
Note	This meta-class represents the timing view for a machine. Tags: atp.Status=draft atp.recommendedPackage=TimingExtensions			
Base	ARElement , ARObject , CollectableElement , Identifiable , MultilanguageReferrable , Packageable Element , Referrable , TimingExtension			
Attribute	Type	Mult.	Kind	Note
machine	Machine	1	ref	This defines the scope of a MachineTiming. All corresponding timing descriptions and constraints shall be defined within this scope. Tags: atp.Status=draft

Table B.13: MachineTiming

Primitive	Numerical
Package	M2::AUTOSARTemplates::GenericStructure::GeneralTemplateClasses::PrimitiveTypes
Note	This primitive specifies a numerical value. It can be denoted in different formats such as Decimal, Octal, Hexadecimal, Float. See the xsd pattern for details. The value can be expressed in octal, hexadecimal, binary representation. Negative numbers can only be expressed in decimal or float notation. Tags: xml.xsd.customType=NUMERICAL-VALUE xml.xsd.pattern=(0[xX][0-9a-fA-F]+) (0[0-7]+) (0[bB][0-1]+) (([\+ -]?[1-9][0-9]+ \.[0-9]+)? [\+ -]?[0-9](\.[0-9]+)?)([eE](\+ -)?[0-9]+)?\.\0 INF -INF NaN xml.xsd.type=string

Table B.14: Numerical

Class	PPortPrototype			
Package	M2::AUTOSARTemplates::SWComponentTemplate::Components			
Note	Component port providing a certain port interface.			
Base	<i>ARObject, AbstractProvidedPortPrototype, AtpBlueprintable, AtpFeature, AtpPrototype, Identifiable, MultilanguageReferrable, PortPrototype, Referrable</i>			
Attribute	Type	Mult.	Kind	Note
provided Interface	PortInterface	0..1	tref	The interface that this port provides. Stereotypes: isOfType

Table B.15: PPortPrototype

Class	PortPrototype (abstract)			
Package	M2::AUTOSARTemplates::SWComponentTemplate::Components			
Note	Base class for the ports of an AUTOSAR software component. The aggregation of PortPrototypes is subject to variability with the purpose to support the conditional existence of ports.			
Base	<i>ARObject, AtpBlueprintable, AtpFeature, AtpPrototype, Identifiable, MultilanguageReferrable, Referrable</i>			
Subclasses	<i>AbstractProvidedPortPrototype, AbstractRequiredPortPrototype</i>			
Attribute	Type	Mult.	Kind	Note
clientServer Annotation	ClientServerAnnotation	*	aggr	Annotation of this PortPrototype with respect to client/server communication.
delegatedPort Annotation	DelegatedPort Annotation	0..1	aggr	Annotations on this delegated port.
ioHwAbstraction Server Annotation	IoHwAbstractionServer Annotation	*	aggr	Annotations on this IO Hardware Abstraction port.
logAndTrace Message CollectionSet	LogAndTraceMessage CollectionSet	0..1	ref	Reference to a collection of Log or Trace messages that will be used by the application. Tags: atp.Status=draft
modePort Annotation	ModePortAnnotation	*	aggr	Annotations on this mode port.
nvDataPort Annotation	NvDataPortAnnotation	*	aggr	Annotations on this non volatile data port.
parameterPort Annotation	ParameterPort Annotation	*	aggr	Annotations on this parameter port.
portPrototype Props	PortPrototypeProps	0..1	aggr	This attribute allows for the definition of further qualification of the semantics of a PortPrototype. Tags: atp.Status=draft
senderReceiver Annotation	SenderReceiver Annotation	*	aggr	Collection of annotations of this ports sender/receiver communication.
triggerPort Annotation	TriggerPortAnnotation	*	aggr	Annotations on this trigger port.

Table B.16: PortPrototype

Class	PortPrototypeBlueprint
Package	M2::AUTOSARTemplates::CommonStructure::StandardizationTemplate::BlueprintDedicated::Port PrototypeBlueprint





Class	PortPrototypeBlueprint			
Note	This meta-class represents the ability to express a blueprint of a PortPrototype by referring to a particular PortInterface. This blueprint can then be used as a guidance to create particular PortPrototypes which are defined according to this blueprint. By this it is possible to standardize application interfaces without the need to also standardize software-components with PortPrototypes typed by the standardized Port Interfaces. Tags: atp.recommendedPackage=PortPrototypeBlueprints			
Base	ARElement , ARObject , AtpBlueprint , AtpClassifier , AtpFeature , AtpStructureElement , CollectableElement , Identifiable , MultilanguageReferrable , PackageableElement , Referrable			
Attribute	Type	Mult.	Kind	Note
initValue	PortPrototypeBlueprint InitValue	*	aggr	This specifies the init values for the dataElements in the particular PortPrototypeBlueprint.
interface	PortInterface	1	ref	This is the interface for which the blueprint is defined. It may be a blueprint itself or a standardized PortInterface
providedCom Spec	PPortComSpec	*	aggr	Provided communication attributes per interface element (data element or operation).
requiredCom Spec	RPortComSpec	*	aggr	Required communication attributes, one for each interface element.

Table B.17: PortPrototypeBlueprint

Class	RPortPrototype			
Package	M2::AUTOSARTemplates::SWComponentTemplate::Components			
Note	Component port requiring a certain port interface.			
Base	ARObject , AbstractRequiredPortPrototype , AtpBlueprintable , AtpFeature , AtpPrototype , Identifiable , MultilanguageReferrable , PortPrototype , Referrable			
Attribute	Type	Mult.	Kind	Note
required Interface	PortInterface	0..1	tref	The interface that this port requires. Stereotypes: isOfType

Table B.18: RPortPrototype

Class	RootSwComponentPrototype			
Package	M2::AUTOSARTemplates::AdaptivePlatform::ApplicationDesign::ApplicationStructure			
Note	The RootSwCompositionPrototype represents the top-level-composition of software components within an Executable. The contained SwComponentPrototypes are fully specified by their SwComponentTypes (including Port Prototypes, PortInterfaces, VariableDataPrototypes, etc.). Tags: atp.Status=draft			
Base	ARObject , AtpFeature , AtpPrototype , Identifiable , MultilanguageReferrable , Referrable			
Attribute	Type	Mult.	Kind	Note
applicationType	SwComponentType	1	tref	This SwComponentType acts as the Type of the RootSw ComponentPrototype. Stereotypes: isOfType Tags: atp.Status=draft

Table B.19: RootSwComponentPrototype

Class	SenderReceiverInterface			
Package	M2::AUTOSARTemplates::SWComponentTemplate::PortInterface			
Note	A sender/receiver interface declares a number of data elements to be sent and received. Tags: atp.recommendedPackage=PortInterfaces			
Base	ARElement , ARObject , AtpBlueprint , AtpBlueprintable , AtpClassifier , AtpType , CollectableElement , DataInterface , Identifiable , MultilanguageReferrable , PackageableElement , PortInterface , Referrable			
Attribute	Type	Mult.	Kind	Note
dataElement	VariableDataPrototype	*	aggr	The data elements of this SenderReceiverInterface.
invalidation Policy	InvalidationPolicy	*	aggr	InvalidationPolicy for a particular dataElement
metaDataItem Set	MetaDataItemSet	*	aggr	This aggregation defines fixed sets of meta-data items associated with dataElements of the enclosing Sender ReceiverInterface

Table B.20: SenderReceiverInterface

Class	ServiceTiming			
Package	M2::AUTOSARTemplates::CommonStructure::Timing::TimingAdaptivePlatform			
Note	This meta-class represents the timing view for one or more service instances. Tags: atp.Status=draft atp.recommendedPackage=TimingExtensions			
Base	ARElement , ARObject , CollectableElement , Identifiable , MultilanguageReferrable , PackageableElement , Referrable , TimingExtension			
Attribute	Type	Mult.	Kind	Note
serviceInstance	AdaptivePlatformServiceInstance	1..*	ref	This defines the scope of a ServiceTiming. All corresponding timing descriptions and constraints shall be defined within this scope. Tags: atp.Status=draft

Table B.21: ServiceTiming

Class	SwComponentPrototype			
Package	M2::AUTOSARTemplates::SWComponentTemplate::Composition			
Note	Role of a software component within a composition.			
Base	ARObject , AtpFeature , AtpPrototype , Identifiable , MultilanguageReferrable , Referrable			
Attribute	Type	Mult.	Kind	Note
type	SwComponentType	0..1	tref	Type of the instance. Stereotypes: isOfType

Table B.22: SwComponentPrototype

Class	SwComponentType (abstract)			
Package	M2::AUTOSARTemplates::SWComponentTemplate::Components			
Note	Base class for AUTOSAR software components.			
Base	ARElement , ARObject , AtpBlueprint , AtpBlueprintable , AtpClassifier , AtpType , CollectableElement , Identifiable , MultilanguageReferrable , PackageableElement , Referrable			
Subclasses	AdaptiveApplicationSwComponentType , AtomicSwComponentType , CompositionSwComponentType , ParameterSwComponentType			





Class		SwComponentType (abstract)		
Attribute	Type	Mult.	Kind	Note
port	PortPrototype	*	aggr	<p>The PortPrototypes through which this SwComponent Type can communicate.</p> <p>The aggregation of PortPrototype is subject to variability with the purpose to support the conditional existence of PortPrototypes.</p> <p>Stereotypes: atpSplittable; atpVariation Tags: atp.Splitkey=port.shortName, port.variationPoint.shortLabel vh.latestBindingTime=preCompileTime</p>
portGroup	PortGroup	*	aggr	<p>A port group being part of this component.</p> <p>Stereotypes: atpVariation Tags:vh.latestBindingTime=preCompileTime</p>
swComponent Documentation	SwComponent Documentation	0..1	aggr	<p>This adds a documentation to the SwComponentType.</p> <p>Stereotypes: atpSplittable; atpVariation Tags: atp.Splitkey=swComponentDocumentation, swComponentDocumentation.variationPoint.shortLabel vh.latestBindingTime=preCompileTime xml.sequenceOffset=-10</p>

Table B.23: SwComponentType

Class		System		
Package	M2::AUTOSARTemplates::SystemTemplate			
Note	<p>The top level element of the System Description.</p> <p>Tags:atp.recommendedPackage=Systems</p>			
Base	<i>ARElement, ARObject, AtpClassifier, AtpFeature, AtpStructureElement, CollectableElement, Identifiable, MultilanguageReferrable, PackageableElement, Referrable</i>			
Attribute	Type	Mult.	Kind	Note
fibexElement	FibexElement	*	ref	<p>Reference to ASAM FIBEX elements specifying Communication and Topology.</p> <p>All Fibex Elements used within a System Description shall be referenced from the System Element.</p> <p>atpVariation: In order to describe a product-line, all Fibex Elements can be optional.</p> <p>Stereotypes: atpVariation Tags:vh.latestBindingTime=postBuild</p>
interpolation Routine MappingSet	InterpolationRoutine MappingSet	*	ref	<p>This reference identifies the InterpolationRoutineMapping Sets that are relevant in the context of the enclosing System.</p>
mapping	SystemMapping	*	aggr	<p>Aggregation of all mapping aspects relevant in the System Description.</p> <p>Stereotypes: atpSplittable; atpVariation Tags: atp.Splitkey=mapping.shortName, mapping.variationPoint.shortLabel vh.latestBindingTime=postBuild</p>
pncVector Length	PositiveInteger	0..1	attr	<p>Length of the partial networking request release information vector (in bytes).</p>





Class	System			
pncVectorOffset	PositiveInteger	0..1	attr	Absolute offset (with respect to the NM-PDU) of the partial networking request release information vector that is defined in bytes as an index starting with 0.
rootSoftwareComposition	RootSwCompositionPrototype	0..1	aggr	Aggregation of the root software composition, containing all software components in the System in a hierarchical structure. This element is not required when the System description is used for a network-only use-case. atpVariation: The RootSwCompositionPrototype can vary. Stereotypes: atpSplittable; atpVariation Tags: atp.Splitkey=rootSoftwareComposition.shortName, rootSoftwareComposition.variationPoint.shortLabel vh.latestBindingTime=systemDesignTime
systemVersion	RevisionLabelString	1	attr	Version number of the System Description.

Table B.24: System

Class	TimingExtensionResource			
Package	M2::AUTOSARTemplates::CommonStructure::Timing::TimingConditional			
Note	A TimingExtensionResource provides the capability to contain instance references referred from within a timing condition formula.			
Base	ARObject, Identifiable, MultilanguageReferrable, Referrable			
Attribute	Type	Mult.	Kind	Note
timingArgument	AutosarOperationArgumentInstance	*	aggr	This refers to an instance reference of an argument of an operation call. Stereotypes: atpSplittable; atpVariation Tags: atp.Splitkey=timingArgument.shortName, timingArgument.variationPoint.shortLabel vh.latestBindingTime=postBuild
timingMode	TimingModeInstance	*	aggr	This refers to an instance reference of a mode declaration. Stereotypes: atpSplittable; atpVariation Tags: atp.Splitkey=timingMode.shortName, timingMode.variationPoint.shortLabel vh.latestBindingTime=postBuild
timingVariable	AutosarVariableInstance	*	aggr	This refers to an instance reference of a variable. Stereotypes: atpSplittable; atpVariation Tags: atp.Splitkey=timingVariable.shortName, timingVariable.variationPoint.shortLabel vh.latestBindingTime=postBuild

Table B.25: TimingExtensionResource

Class	TimingModeInstance			
Package	M2::AUTOSARTemplates::CommonStructure::Timing::TimingConditional			
Note	This class specifies the mode declaration to be checked in a specific instance of a mode declaration group. This is used in a timing condition formula as an operand of the unary timing function TIMEX_mode Active to check whether the mode declaration is active at the point in time this expression is evaluated.			
Base	ARObject, Identifiable, MultilanguageReferrable, Referrable			





Class	TimingModelInstance			
Attribute	Type	Mult.	Kind	Note
modelInstance	ModelInSwcBsw InstanceRef	0..1	aggr	This refers to a specific mode declaration in the given context.

Table B.26: TimingModelInstance

Class	Traceable (abstract)			
Package	M2::MSR::Documentation::BlockElements::RequirementsTracing			
Note	This meta class represents the ability to be subject to tracing within an AUTOSAR model. Note that it is expected that its subclasses inherit either from MultilanguageReferrable or from Identifiable. Nevertheless it also inherits from MultilanguageReferrable in order to provide a common reference target for all Traceables.			
Base	ARObject, MultilanguageReferrable, Referrable			
Subclasses	StructuredReq, TimingConstraint , TraceableTable, TraceableText			
Attribute	Type	Mult.	Kind	Note
trace	Traceable	*	ref	This association represents the ability to trace to upstream requirements / constraints. This supports for example the bottom up tracing ProjectObjectives <- MainRequirements <- Features <- RequirementSpecs <- BSW/AI Tags: xml.sequenceOffset=20

Table B.27: Traceable

Class	VariableDataPrototype			
Package	M2::AUTOSARTemplates::SWComponentTemplate::Datatype::DataPrototypes			
Note	A VariableDataPrototype is used to contain values in an ECU application. This means that most likely a VariableDataPrototype allocates "static" memory on the ECU. In some cases optimization strategies might lead to a situation where the memory allocation can be avoided. In particular, the value of a VariableDataPrototype is likely to change as the ECU on which it is used executes.			
Base	ARObject, AtpFeature, AtpPrototype, AutosarDataPrototype, DataPrototype, Identifiable, MultilanguageReferrable, Referrable			
Attribute	Type	Mult.	Kind	Note
initValue	ValueSpecification	0..1	aggr	Specifies initial value(s) of the VariableDataPrototype

Table B.28: VariableDataPrototype

C Splitable Elements in the Scope of this Document

This chapter contains a table of all model elements stereotyped `<<atpSplitable>>` in the scope of this document.

Each entry in the following table consists of the identification of the specific model element itself and the applicable value of the tagged value `atp.Splitkey`.

For more information about the concept of splitable model elements and how these shall be treated please refer to [5].

Name of splitable element	Splitkey
TimingExtension.timingCondition	timingCondition.shortName, timingCondition.variationPoint.shortLabel
TimingExtension.timingDescription	timingDescription.shortName, timingDescription.variationPoint.shortLabel
TimingExtension.timingGuarantee	timingGuarantee.shortName, timingGuarantee.variationPoint.shortLabel
TimingExtension.timingRequirement	timingRequirement.shortName, timingRequirement.variationPoint.shortLabel
TimingExtension.timingResource	timingResource.shortName
TimingExtensionResource.timingArgument	timingArgument.shortName, timingArgument.variationPoint.shortLabel
TimingExtensionResource.timingMode	timingMode.shortName, timingMode.variationPoint.shortLabel
TimingExtensionResource.timingVariable	timingVariable.shortName, timingVariable.variationPoint.shortLabel

Table C.1: Usage of splitable elements

D Variation Points in the Scope of this Document

This chapter contains a table of all model elements stereotyped `<<atpVariation>>` in the scope of this document.

Each entry in the following table consists of the identification of the model element itself and the applicable value of the tagged value `vh.latestBindingTime`.

For more information about the concept of variation points and how model elements that contain variation points shall be treated please refer to [5].

Variation Point	Latest Binding Time
TimingExtension.timingCondition	postBuild
TimingExtension.timingDescription	postBuild
TimingExtension.timingGuarantee	postBuild
TimingExtension.timingRequirement	postBuild
TimingExtensionResource.timingArgument	postBuild
TimingExtensionResource.timingMode	postBuild
TimingExtensionResource.timingVariable	postBuild

Table D.1: Usage of variation points