

Document Title	Specification of Vehicle-2-X Geo Networking
Document Owner	AUTOSAR
Document Responsibility	AUTOSAR
Document Identification No	793

Document Status	published
Part of AUTOSAR Standard	Classic Platform
Part of Standard Release	R19-11

Document Change History			
Date	Release	Changed by	Change Description
2019-11-28	R19-11	AUTOSAR Release Management	<ul style="list-style-type: none"> Added support for C2CCC BSP 1.3 Changed Document Status from Final to published
2018-10-31	4.4.0	AUTOSAR Release Management	<ul style="list-style-type: none"> Update ETSI EN 302 636-4-1 v1.3.1 Corrections on init and configuration Corrections in Tx and Rx flows Editorial changes
2017-12-08	4.3.1	AUTOSAR Release Management	<ul style="list-style-type: none"> Editorial changes
2016-11-30	4.3.0	AUTOSAR Release Management	<ul style="list-style-type: none"> Initial Release

Disclaimer

This work (specification and/or software implementation) and the material contained in it, as released by AUTOSAR, is for the purpose of information only. AUTOSAR and the companies that have contributed to it shall not be liable for any use of the work.

The material contained in this work is protected by copyright and other types of intellectual property rights. The commercial exploitation of the material contained in this work requires a license to such intellectual property rights.

This work may be utilized or reproduced without any modification, in any form or by any means, for informational purposes only. For any other purpose, no part of the work may be utilized or reproduced, in any form or by any means, without permission in writing from the publisher.

The work has been developed for automotive applications only. It has neither been developed, nor tested for non-automotive applications.

The word AUTOSAR and the AUTOSAR logo are registered trademarks.

Table of Contents

1	Introduction and functional overview	5
1.1	Architectural overview	5
1.2	Functional overview.....	6
2	Acronyms and abbreviations	7
3	Related documentation.....	8
3.1	Input documents.....	8
3.2	Related standards and norms	8
3.3	Related specification	10
4	Constraints and assumptions	11
4.1	Limitations	11
4.2	Applicability to car domains.....	11
4.3	Authorisation Tickets and Pseudonyms	11
5	Dependencies to other modules.....	12
5.1	AUTOSAR DET (Default Error Tracer).....	12
5.2	AUTOSAR EcuM (Ecu State Manager).....	12
5.3	AUTOSAR Ethernet Interface (EthIf).....	12
5.4	AUTOSAR Vehicle-2-X Basic Transport Protocol (V2xBtp)	12
5.5	AUTOSAR Vehicle-2-X Management (V2XM)	12
5.6	File structure	12
5.6.1	Code file structure.....	12
6	Requirements traceability	13
7	Functional specification	16
7.1	General Functionality	16
7.2	GeoNetworking Packet Structure and Format.....	16
7.3	GeoNetworking Protocol Operations	17
7.3.1	Network Management.....	17
7.3.2	Security Mechanisms.....	17
7.4	Message Forwarding.....	18
7.5	Message Transmission	18
7.6	Message Reception.....	19
7.7	Error classification	20
7.7.1	Development Errors	20
7.7.2	Runtime Errors.....	20
7.7.3	Transient Faults	20
7.7.4	Production Errors.....	21
7.7.5	Extended Production Errors.....	21
8	API specification.....	22
8.1	Imported types.....	22
8.2	Type definitions	23
8.2.1	V2xGn_TxParamsType.....	23
8.3	Function definitions	24

8.3.1	V2xGn_Init	24
8.3.2	V2xGn_GetVersionInfo	24
8.3.3	V2xGn_V2xM_PreparePseudonymChange	25
8.3.4	V2xGn_V2xM_CommitPseudonymChange	26
8.3.5	V2xGn_V2xM_AbortPseudonymChange	27
8.3.6	V2xGn_Transmit	28
8.4	Call-back notifications	29
8.4.1	This is a list of functions provided for other modules. V2xGn_V2xM_EncapConfirmation	29
8.4.2	V2xGn_V2xM_DecapConfirmation	30
8.4.3	V2xGn_RxIndication	31
8.4.4	V2xGn_TxConfirmation	32
8.5	Scheduled functions	33
8.5.1	V2xGn_MainFunction	33
8.6	Expected Interfaces	33
8.6.1	Mandatory Interfaces	33
8.6.2	Optional Interfaces	34
9	Sequence diagrams	36
9.1	V2xGn_RxIndication	36
9.2	V2xGn_Transmit	37
9.3	V2xGn_V2xM_UpdatePseudonym	38
9.4	V2xGn_MainFunction	38
10	Configuration specification	39
10.1	Containers and configuration parameters	39
10.1.1	Variants	39
10.1.2	V2xGn	39
10.1.3	V2xGnGeneral	40
10.1.4	V2xGnBeaconService	46
10.1.5	V2xGnPacketForwarding	47
10.2	Published Information	53
11	Not applicable requirements	54

1 Introduction and functional overview

This specification specifies the functionality, API and the configuration of the AUTOSAR Basic Software module Vehicle-2-X GeoNetworking (V2xGn).

V2xGn together with Vehicle-2-X Facilities (V2xFac) [8], Vehicle-2-X Basic Transport (V2xBtp) [9], Vehicle-2-X Management (V2xM) [10] and AUTOSAR BSW modules Ethernet Interface (EthIf) [5], Wireless Ethernet Driver (WEth) [11] and Wireless Ethernet Transceiver Driver (WEthTrcv) [12] forms the V2X stack within the AUTOSAR architecture.

The base for this document is the GeoNetworking specification [19][20]. It is assumed that the reader is familiar with this specification.

1.1 Architectural overview

V2xGn provides services to and is dependent on the upper V2xBtp module and uses the services of and gets services from the lower EthIf module to realize its functions explained in sections 1.2 and chapter 7 of this document.

Positioning of the V2xGn module within the AUTOSAR BSW and the Layered Software architecture [1] is shown in Figure 1.

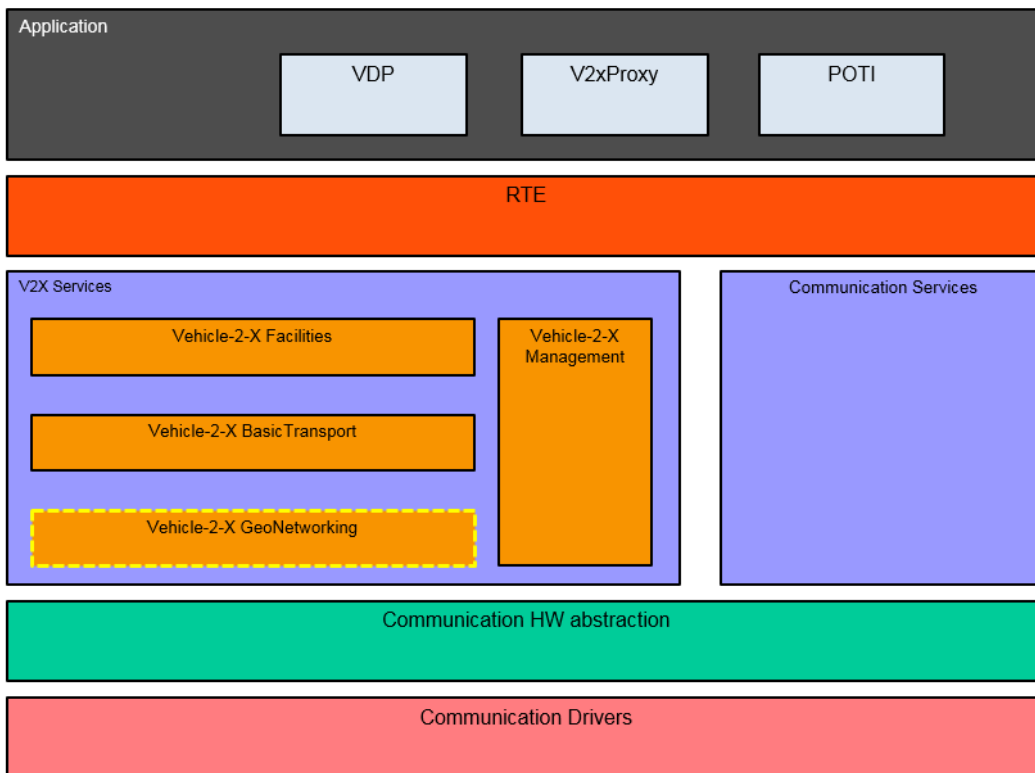

Figure 1 – AUTOSAR BSW software architecture – V2xGn module scope

1.2 Functional overview

The internal functionality of the V2xGn module should comply to the medium independent specification of the GeoNetworking protocol [19] and the medium dependent specification of the GeoNetworking protocol [20], relying on ETSI ITS-G5 technology as medium. The module provides services to the upper V2xBtp module specified in [9] and in order to provide its packet transport services, it relies on the lower Ethlf module [5]. Vehicle-2-X specific data is also exchanged with the V2xM module.

GeoNetworking protocol is a set of network layer functionalities that enables ad hoc communication without infrastructure support using geographical positions of the communicating entities. It supports communication among individual Intelligent Transport System (ITS) station and distribution of packets in geographical areas. As GeoNetworking can be executed over different ITS technologies such as ITS-G5 and infrared, GeoNetworking specification consists of a standard for media-independent functionality [19] which specifies all functions that are common to all ITS access technologies and one or more media-dependent specifications [20] which includes extensions for a specific ITS technology.

2 Acronyms and abbreviations

The following acronyms and abbreviations have a local scope and are therefore not contained in the AUTOSAR glossary [4].

<i>Abbreviation / Acronym:</i>	<i>Description:</i>
BTP	Basic Transport Protocol
CBF	Contention-Based Forwarding
DET	Default Error Tracer
GAC	GeoAnycast
GBC	GeoBroadcast
GN	GeoNetworking
GN-SDU	GeoNetworking Service Data Unit
ITS	Intelligent Transport System
MAC	Medium Access Control
SHB	Single Hop Broadcast
TC	Traffic Class
TSB	Topologically Scoped Broadcast

3 Related documentation

3.1 Input documents

- [1] AUTOSAR Layered Software Architecture
AUTOSAR_EXP_LayeredSoftwareArchitecture.pdf
- [2] AUTOSAR General Requirements on Basic Software Modules
AUTOSAR_SRS_BSWGeneral.pdf
- [3] AUTOSAR General Specification for Basic Software Modules
AUTOSAR_SWS_BSWGeneral.pdf
- [4] Glossary
AUTOSAR_TR_Glossary
- [5] Specification of Ethernet Interface
AUTOSAR_SWS_EthernetInterface.pdf
- [6] Specification of ECU State Manager
AUTOSAR_SWS_ECUSTateManager.pdf
- [7] Specification of Default Error Tracer
AUTOSAR_SWS_DefaultErrorTracer.pdf
- [8] Specification of Vehicle-2-X Facilities
AUTOSAR_SWS_V2XFacilities.pdf
- [9] Specification of Vehicle-2-X Basic Transport
AUTOSAR_SWS_V2XBasicTransport.pdf
- [10] Specification of Vehicle-2-X Management
AUTOSAR_SWS_V2XManagement.pdf
- [11] Specification of Wireless Ethernet Driver
AUTOSAR_SWS_WirelessEthernetDriver.pdf
- [12] Specification of Wireless Ethernet Transceiver Driver
AUTOSAR_SWS_WirelessEthernetTransceiverDriver.pdf
- [13] Requirements on Vehicle-2-X communication
AUTOSAR_SRS_V2XCommunications.pdf

3.2 Related standards and norms

- [14] Intelligent Transport Systems (ITS); Communications Architecture
ETSI EN 302 665 V1.1.1 (2010-09)

- [15] Intelligent Transport Systems (ITS); Vehicular Communications;
GeoNetworking; Part 1: Requirements
ETSI EN 302 636-1 V1.2.1 (2014-04)
- [16] Intelligent Transport Systems (ITS); Vehicular Communications;
GeoNetworking; Part 2: Scenarios
ETSI EN 302 636-2 V1.2.1 (2013-11)
- [17] Intelligent Transport Systems (ITS); Vehicular Communications
GeoNetworking Part 3: Network Architecture
ETSI EN 302 636-3 V1.2.1 (2014-12)
- [18] Intelligent Transport Systems (ITS); Vehicular Communications;
GeoNetworking; Part 5: Transport Protocols; Sub-part 1: Basic Transport
Protocol
ETSI EN 302 636-5-1 V2.1.1 (2017-08)
- [19] Intelligent Transport Systems (ITS); Vehicular Communications;
GeoNetworking Part 4: Geographical addressing and forwarding for point-to-
point and point-to-multipoint communications; Sub-part 1: Media-Independent
Functionality
ETSI EN 302 636-4-1 V1.3.1 (2017-08)
- [20] Intelligent Transport Systems (ITS); Vehicular Communications;
GeoNetworking; Part 4: Geographical addressing and forwarding for point-to-
point and point-to-multipoint communications; Sub-part 2: Media-dependent
functionalities for ITS-G5
ETSI TS 102 636-4-2 V1.1.1 (2013-10)
- [21] Intelligent Transport Systems (ITS); OSI cross-layer topics; Part 8: Interface
between security entity and network and transport layer
ETSI TS 102 723-8
- [22] Intelligent Transport Systems (ITS); OSI cross-layer topics; Part 10: Interface
between access layer and network and transport layer
ETSI TS 102 723-10 V1.1.1 (2012-11)
- [23] C2C-CC BSP Requirement
C2CCC_RS_2037_BSP_Requirements.docx
- [24] Intelligent Transport Systems (ITS); Harmonized Channel Specifications for
Intelligent Transport Systems operating in the 5 GHz frequency band between
access layer and network and transport layer
ETSI TS 102 724 V1.1.1 (2012-10)
- [25] List of EtherTypes by IEEE
<http://standards.ieee.org/develop/regauth/ethertype/eth.txt>

3.3 Related specification

AUTOSAR provides a General Specification on Basic Software (SWS BSW General) [3] which is also valid for V2xGn.

Thus, the specification SWS BSW General [3] shall be considered as additional and required specification for V2xGn.

4 Constraints and assumptions

4.1 Limitations

- The GeoNetworking protocol and therefore the V2xGn module requires a broadcast capable access layer in order to provide transmit services.
- Wireless Communication supports IEEE 802.11p only. Other 802.11 standards (e.g. for infrastructure networks and integration with TCP/IP) can be extended in future releases of the AUTOSAR standard.
- The V2X modules follow the guidance regarding the Day-1 scenarios defined by the Basic System Standards Profile from Car-2-Car-Consortium.
- AUTOSAR R19-11 only focuses on the European version of car-to-car communication as defined by ETSI. Extension to other regions are planned for future releases of the AUTOSAR standard.

4.2 Applicability to car domains

This specification is applicable to all car domains.

4.3 Authorisation Tickets and Pseudonyms

The Authorisation Ticket (AT) is referred to as Pseudonym in this document.

5 Dependencies to other modules

This section describes the relations of the V2xGn module to other modules within the AUTOSAR basic software architecture. It outlines the modules that are required or optional for the realization of the V2xGn module and the V2xGn services that these modules use.

5.1 AUTOSAR DET (Default Error Tracer)

In development mode, the V2xGn module reports errors through DET [7].

5.2 AUTOSAR EcuM (Ecu State Manager)

The EcuM [6] is responsible for the initialization of V2xGn.

5.3 AUTOSAR Ethernet Interface (EthIf)

The Ethernet Interface is the lower layer module of the V2xGn module.

5.4 AUTOSAR Vehicle-2-X Basic Transport Protocol (V2xBtp)

The V2xBtp is the upper layer module of the V2xGn module.

5.5 AUTOSAR Vehicle-2-X Management (V2xM)

V2xM is used for interchange of Data with other V2X-Modules. Security mechanisms are configured by the V2xM and are used by V2xGn.

5.6 File structure

5.6.1 Code file structure

For details refer to the chapter 5.1.6 “Code file structure” in *SWS_BSWGeneral* [3].

6 Requirements traceability

Requirement	Description	Satisfied by
SRS_BSW_00345	BSW Modules shall support pre-compile configuration	SWS_V2xGn_00078
SRS_V2X_00010	The implementation of the V2X system shall follow additional guidance given by C2C-CC requirements	SWS_V2xGn_00269, SWS_V2xGn_20169, SWS_V2xGn_20181, SWS_V2xGn_20260, SWS_V2xGn_20262, SWS_V2xGn_20263, SWS_V2xGn_20264, SWS_V2xGn_20265, SWS_V2xGn_20266, SWS_V2xGn_20267, SWS_V2xGn_20268, SWS_V2xGn_20270, SWS_V2xGn_20401
SRS_V2X_00160	The V2X system shall use end-to-end security for communication to external entities	SWS_V2xGn_00026, SWS_V2xGn_20251
SRS_V2X_00161	The V2X system shall employ the security envelope on its Network layer	SWS_V2xGn_00012, SWS_V2xGn_20251
SRS_V2X_00163	The "verification" of a message shall comprise at least cryptographic verification of the message's signature	SWS_V2xGn_NA_3
SRS_V2X_00164	The V2X system shall only forward verified messages	SWS_V2xGn_00026
SRS_V2X_00174	The V2X system shall support key origin authentication for the new (long-term or pseudonym) public keys that are provided in certificate signing requests	SWS_V2xGn_NA_3
SRS_V2X_00176	The V2X system shall change pseudonyms	SWS_V2xGn_00028, SWS_V2xGn_00091, SWS_V2xGn_00112, SWS_V2xGn_00115
SRS_V2X_00184	The V2X system shall allow applications to block the pseudonym change	SWS_V2xGn_NA_3
SRS_V2X_00189	The V2X system shall be able to estimate vehicle states	SWS_V2xGn_NA_4
SRS_V2X_00190	The V2X system shall handle vehicle states in a consistent manner	SWS_V2xGn_NA_4
SRS_V2X_00193	The V2X system shall use ITS time as time base	SWS_V2xGn_NA_4
SRS_V2X_00207	The difference between Station clock and time base shall be estimated	SWS_V2xGn_NA_4
SRS_V2X_00214	The V2X system shall allow applications to deactivate transmission of CAMs	SWS_V2xGn_NA_4
SRS_V2X_00232	The V2X system shall	SWS_V2xGn_NA_1

	cooperate with tolling zone stations in vicinity	
SRS_V2X_00239	-	SWS_V2xGn_NA_1
SRS_V2X_00242	The V2X system shall manage CAM transmission in such a way, that no outdated CAM will be transmitted	SWS_V2xGn_NA_1
SRS_V2X_00245	The V2X system shall support per-packet transmission power control	SWS_V2xGn_NA_1
SRS_V2X_00259	The V2X system shall manage the life time of all DENM packets	SWS_V2xGn_20259
SRS_V2X_00279	The V2X system shall support circular, rectangular and ellipsoidal geographical areas	SWS_V2xGn_20266
SRS_V2X_00291	The V2X system shall only send messages with valid position and time	SWS_V2xGn_NA_2
SRS_V2X_00301	The V2X system's Facility Layer shall handle DENM repetition	SWS_V2xGn_NA_2
SRS_V2X_00318	The V2X system's Facility Layer shall generate traces and path histories	SWS_V2xGn_NA_2
SRS_V2X_00322	The V2X system shall provide services to avoid channel congestion of the shared media	SWS_V2xGn_NA_1
SRS_V2X_00323	The V2X system shall provide mitigation techniques to avoid disturbing other services operating at nearby frequencies	SWS_V2xGn_NA_4
SRS_V2X_00391	The V2X system's access layer shall be ITS-G5 compliant	SWS_V2xGn_20414, SWS_V2xGn_NA_1
SRS_V2X_00405	The V2X basic system shall support services for confidentiality	SWS_V2xGn_NA_3
SRS_V2X_00406	The end-to-end security envelope shall be generated depending on the message type	SWS_V2xGn_NA_3
SRS_V2X_00407	The signature in the end-to-end security envelope shall be generated using a private key corresponding to a valid authorization ticket (pseudonym certificate)	SWS_V2xGn_NA_3
SRS_V2X_00412	The V2X system shall inform the driver about the expiration	SWS_V2xGn_NA_3

	of the pseudonym certificates	
SRS_V2X_00413	The V2X system shall inform the driver about the expiration of the Long Term Certificates	SWS_V2xGn_NA_3
SRS_V2X_00451	The V2X system's access layer shall be compliant to the ETSI Harmonized Channel Specifications	SWS_V2xGn_NA_1
SRS_V2X_00511	The V2X system shall provide services for communication to multiple, geographically scattered and movable entities	SWS_V2xGn_NA_4
SRS_V2X_00531	The V2X system's Networking Layer shall support addressing based on geographic coordinates	SWS_V2xGn_20250, SWS_V2xGn_20251, SWS_V2xGn_20252, SWS_V2xGn_20255, SWS_V2xGn_20258, SWS_V2xGn_20414, SWS_V2xGn_20416
SRS_V2X_00693	The V2X system shall provide functionality for generating traces and path histories	SWS_V2xGn_NA_4
SRS_V2X_00711	The V2X system's CA basic service shall be compliant to ETSI Specification of Cooperative Awareness Basic Service	SWS_V2xGn_NA_2
SRS_V2X_00741	The V2X system's DEN basic service shall be compliant to ETSI Specifications of Decentralized Environmental Notification Basic Service	SWS_V2xGn_NA_2

Note:

Requirement IDs within this document have an encoding to state where each requirement has its origin:

- SWS items starting with a leading 0 (SWS_V2xM_0xxxx) are module specific and not inherited.
- SWS items starting with a leading 2 (SWS_V2xM_2xxxx) are inherited from C2C-CC Basic System Profile

7 Functional specification

7.1 General Functionality

[SWS_V2xGn_00012] [The V2xGn Module shall implement the GeoNetworking Protocol as defined in [19], [20] and [23] unless specified otherwise in this document.] (SRS_V2X_00161)

[SWS_V2xGn_00013] [The GeoNetworking Protocol shall support the GeoNetworking related requirements specified in [23]] ()

[SWS_V2xGn_20250] [All default constants and parameters of the V2xGn module not defined or overwritten in the current document shall be set as specified in Annex H of [19].] (SRS_V2X_00531)

[SWS_V2xGn_20251] [The V2xGn module shall be implemented assuming the ETSI parameter itsGnSecurity is constantly set to ENABLED.] (SRS_V2X_00531, SRS_V2X_00160, SRS_V2X_00161)

[SWS_V2xGn_20252] [The V2xGn module shall only support anonymous address configuration mode.] (SRS_V2X_00531)

[SWS_V2xGn_20255] [The V2xGn module shall support geo-areas areas of up to 80 km². In consequence, the itsGnMaxGeoAreaSize shall have a value of 80. It is configurable by the configuration option V2xGnItsGnMaxGeoAreaSize.] (SRS_V2X_00531)

[SWS_V2xGn_20414] [The V2xGn module shall be implemented with respect to the ETSI parameter itsGnIfType constantly set to ITS-G5.] (SRS_V2X_00531, SRS_V2X_00391)

[SWS_V2xGn_00130] [The V2xGn module shall get the pointer to the current time information via V2xM_GetRefTimePtr within the V2xGn_Init function.] ()

[SWS_V2xGn_20416] [Packet repetition shall not be performed by V2xGn module and the corresponding steps in the packet handling procedures in [19] clause 10.3 shall not be executed.

The parameter 'Maximum repetition time' of the service primitive GN-DATA.request is not applicable. Also, the GN protocol constant itsGnMinPacketRepetitionInterval is not applicable.] (SRS_V2X_00531)

7.2 GeoNetworking Packet Structure and Format

[SWS_V2xGn_00020] [The GeoNetworking protocol shall only support the packet header types Single Hop Broadcast packet header, GeoBroadcast packet headers and Beacon packet header.

] ()

[SWS_V2xGn_20258] | The V2xGn module shall set the LifeTime field of all SHB packets to 1 second. Consequently, the multiplier bit of the LT field shall be set to 1 and the base bit of the LT field shall be set to 1. | (SRS_V2X_00531)

[SWS_V2xGn_20259] | The V2xGn module shall set the LifeTime field of all GBC packets to the value of the maxPacketLifetime from the transmit parameters TxParams. The value of the LifeTime field shall not exceed the itsGnMaxPacketLifetime, specified in [19], Annex H. | (SRS_V2X_00259)

7.3 GeoNetworking Protocol Operations

7.3.1 Network Management

[SWS_V2xGn_00022] | The V2xGn module shall update the local position and time information. The minimum update frequency is configured by the configuration parameter `V2xGnItsGnMinUpdateFrequencyEPV`. The scheduled function `V2xGn_MainFunction()` shall be used for the cyclic update. | ()

[SWS_V2xGn_00023] | The V2xGn module shall support GeoNetworking beaconing. The scheduled function `V2xGn_MainFunction()` shall be used for the cyclic beaconing. | ()

[SWS_V2xGn_00269] | The V2xGn module shall only send beacons if ego position is accurate enough to set the Position Accuracy Indicator (PAI) to 1. | (SRS_V2X_00010)

[SWS_V2xGn_00081] | The V2xGn module shall support Location Table Maintenance. The scheduled function `V2xGn_MainFunction()` shall be used for the cyclic maintenance of the Location Table. | ()

[SWS_V2xGn_00129] | The V2xGn module shall get the current position and time information via `V2xM_GetPositionAndTime` within the `MainFunction`. | ()

7.3.2 Security Mechanisms

[SWS_V2xGn_00026] | The V2xGn module shall use security services provided by `V2xM_V2xGn_ReqEncap` and `V2xM_V2xGn_ReqDecap`. | (SRS_V2X_00160, SRS_V2X_00164)

[SWS_V2xGn_00028] | The V2xGn shall suspend transmission of messages and clear transmit buffers when a pseudonym change is in preparation. | (SRS_V2X_00176)

Note: The V2xM will notify the V2xGn about pseudonym changes via `V2xGn_V2xM_PreparePseudonymChange`, `V2xGn_V2xM_CommitPseudonymChange` and `V2xGn_V2xM_AbortPseudonymChange`.

7.4 Message Forwarding

[SWS_V2xGn_20266] [The V2xGn module shall only support Area forwarding algorithms specified in [19] Annex E.3.] (SRS_V2X_00010, SRS_V2X_00279)

[SWS_V2xGn_20267] [When forwarding packets, the V2xGn module shall use the DCC profile DP3 as defined in [24].] (SRS_V2X_00010)

[SWS_V2xGn_20169] [The V2xGn module shall check the distance from the sender position - in the security envelope, if available - and forward only messages with a distance from the sender of equal or less than 6 km.] (SRS_V2X_00010)

7.5 Message Transmission

[SWS_V2xGn_00034] [The V2xGn module shall provide the API `V2xGn_Transmit()` to enable transmit requests from the V2xBtp Module.] ()

[SWS_V2xGn_00082] [The V2xGn module shall use `EthIf_ProvideTxBuffer` to acquire a buffer within the Wireless Ethernet Driver for a V2X Packet to be transmitted. This has to be done during the `V2xGn_Transmit` context.]()

[SWS_V2xGn_00083] [The V2xGn module shall provide transmission parameters to the Wireless Ethernet Driver for a V2X Packet to be transmitted via an API call to `EthIf_SetBufWTxParams`. This has to be done during the `V2xGn_Transmit` context.]()

[SWS_V2xGn_00035] [The V2xGn module shall transmits packets using the `EthIf_Transmit()` API provided by the `EthIf` Module. This has to be done during the `V2xGn_Transmit` context.] ()

[SWS_V2xGn_00036] [If the configuration parameter `V2xGnTxConfirmation` is enabled, the V2xGn module shall provide information about the status of the transmission with an associated ID (generated by the `V2xFac` module and handed down to track the status of the packet) to the V2xBtp Module via the `V2xBtp_TxConfirmation()` callback.] ()

[SWS_V2xGn_20260] [The V2xGn module shall buffer GBC packets when no neighbours are available (store-carry-forward) if the SCF bit of the TC (Traffic Class) field of GBC packets is set to 1.] (SRS_V2X_00010)

[SWS_V2xGn_20262] [The V2xGn module is not required to offload packets to another channel. Consequently, the channel offload bit of the TC (Traffic Class) field in the BTP frames to be sent should be set to 0. Value 1 will be ignored anyway.] (SRS_V2X_00010)

[SWS_V2xGn_20263] [The V2xGn module shall only use the DCC profiles specified in [SWS_WEth_20235]. Consequently, the DCC Profile ID bits of the TC (Traffic Class) field shall only use the DPID values defined in **[SWS_WEth_20235]**.] (SRS_V2X_00010)

[SWS_V2xGn_20264] [The V2xGn shall set the itsGnIsMobile bit of the Flags field to 1.] (SRS_V2X_00010)

[SWS_V2xGn_20265] [The V2xGn shall set the Maximum Hop Limit (MHL) field to 10.] (SRS_V2X_00010)

[SWS_V2xGn_20270] [All GeoNetworking frames sent by the V2xGn module shall use the EtherType value 0x8947 as listed by the IEEE Registration Authority at [25].] (SRS_V2X_00010)

[SWS_V2xGn_20401] [The GN Source Address shall be constructed as follows:

- Set the field M (bit 0) to 0.
- Set the field ST (bits 1 to 5) to the station type of the ITS-S. The station type in the GN source address shall be identical to the station type in CAMs/DENMs.
- Set reserved bits 6 to 15 to 0.
- Set the field MID (bits 16 to 63) to the value of the MAC address.

] (SRS_V2X_00010)

[SWS_V2xGn_00128] [The V2xGn module shall call V2xM_GetGlobalTxParams that delivers own channel CBR information set in the GeoNetworking header to be transmitted.] ()

7.6 Message Reception

[SWS_V2xGn_00038] [The V2xGn module shall create a unique TransactionId for each received packet. This TransactionId is handed up to track the received packets and is used for verification on demand.] ()

[SWS_V2xGn_00039] [The V2xGn module shall indicate received packets via the V2xBtp_RxIndication() callback to the BTP module.] ()

[SWS_V2xGn_00084] [The V2xGn module shall get the reception status of a received packet during the V2xGn_RxIndication() from the EthIf module with a call to EthIf_GetBufWRxParams().] ()

[SWS_V2xGn_20268] [The V2xGn module shall only use duplicate packet detection as specified in [19] Annex A.2 and A.3.] (SRS_V2X_00010)

[SWS_V2xGn_20181] [If the V2xGn module detects a collision of the least significant 32 bit of the "Certificate digest" / "hashedId8" with the "Certificate digest" / "hashedId8" of another ITS station, it shall initiate a change of its authorization ticket (pseudonym) only if the certificate corresponding to the other "Certificate digest" / "hashedId8" is valid, and the current authorization ticket was selected according to rules defined in SWS_V2xM_00201 (that is to say no such collision has already triggered the change to the current authorization ticket).] (SRS_V2X_00010)

[SWS_V2xGn_00127] [The V2xGn module shall call V2xM_SetGlobalRxParams with CBR information extracted from the GeoNetworking header.] ()

[SWS_V2xGn_00131] [The V2xGn module shall use V2xM_CalcDistance when calculations of geographical distances are necessary for the V2xGn protocol operations.] ()

7.7 Error classification

This chapter lists and classifies all errors that can be detected within this software module. Each error is classified according to relevance (development / production) and related error code. For development errors, a value is defined.

7.7.1 Development Errors

[SWS_V2xGn_00041] The following table lists development errors that shall be distinguished by the V2xGn module. V2xGn shall report them to the DET, if development error detection is enabled.

<i>Type of error</i>	<i>Related error code</i>	<i>Value [hex]</i>
API service called with invalid parameter	V2XGN_E_PARAM	0x01
API service called with invalid pointer	V2XGN_E_PARAM_POINTER	0x02
API service used without module initialization	V2XGN_E_UNINIT	0x03
API service called with invalid configuration pointer	V2XGN_E_INIT_FAILED	0x04

] ()

7.7.2 Runtime Errors

There are no runtime errors.

7.7.3 Transient Faults

There are no transient faults.

7.7.4 Production Errors

There are no production errors.

7.7.5 Extended Production Errors

There are no extended production errors.

8 API specification

8.1 Imported types

In this chapter all types included from the following modules are listed:

[SWS_V2xGn_00042]

<i>Module</i>	<i>Header File</i>	<i>Imported Type</i>
ComStack_Types	ComStack_Types.h	BufReq_ReturnType
Eth_GeneralTypes	Eth_GeneralTypes.h	Eth_BufIdxType
	Eth_GeneralTypes.h	Eth_FrameType
Std	Std_Types.h	Std_ReturnType
	Std_Types.h	Std_VersionInfoType
V2x_GeneralTypes	Rte_V2xM_Type.h	V2xM_PositionAndTimeType
	Rte_V2xM_Type.h	V2xM_SecReportType
	V2x_GeneralTypes.h	V2x_ChanType
	V2x_GeneralTypes.h	V2x_GnAddressType
	V2x_GeneralTypes.h	V2x_GnAreaShapeType
	V2x_GeneralTypes.h	V2x_GnDestinationAreaType
	V2x_GeneralTypes.h	V2x_GnDestinationType
	V2x_GeneralTypes.h	V2x_GnLongPositionVectorType
	V2x_GeneralTypes.h	V2x_GnPacketTransportType
	V2x_GeneralTypes.h	V2x_GnTxResultType
	V2x_GeneralTypes.h	V2x_GnUpperProtocolType
	V2x_GeneralTypes.h	V2x_PseudonymType
	V2x_GeneralTypes.h	V2x_SecProfileType
	V2x_GeneralTypes.h	V2x_SecReturnType
V2x_GeneralTypes.h	V2x_TrafficClassIdType	
V2xBtp	V2xBtp.h	V2xBtp_RxParamsType
WEth_GeneralTypes	WEth_GeneralTypes.h	WEth_BufWRxParamIdType
	WEth_GeneralTypes.h	WEth_BufWTxParamIdType

l)

8.2 Type definitions

8.2.1 V2xGn_TxParamsType

[SWS_V2xGn_00063]

Name	V2xGn_TxParamsType	
Kind	Structure	
Elements	upperProtocol	
	Type	V2x_GnUpperProtocolType
	Comment	The protocol which triggered the request. (e.g. BTP-A or BTP-B)
	transportType	
	Type	V2x_GnPacketTransportType
	Comment	Specifies the packet transportation type
	destinationAddress	
	Type	V2x_GnAddressType
	Comment	Destination address for GeoUnicast packet
	destinationArea	
	Type	V2x_GnDestinationAreaType
	Comment	Destination area for GeoBroadcast/GeoAnycast packet.
	destinationType	
	Type	V2x_GnDestinationType
	Comment	Select which destination type (destinationAddress or destinationArea is used for this packet).
	secProfile	
	Type	V2x_SecProfileType
	Comment	Parameters depending on the security service.
	maxPacketLifetime	
	Type	uint16
Comment	Time a packet can be buffered until it reaches the destination.	
trafficClassId		
Type	V2x_TrafficClassIdType	
Comment	Set of parameter specifying the traffic class for the message.	
Description	Structure containing parameters for the V2xGn_Transmit() API.	

Available via	V2xGn.h
----------------------	---------

]()

8.3 Function definitions

8.3.1 V2xGn_Init

[SWS_V2xGn_00068]

Service Name	V2xGn_Init	
Syntax	<pre>void V2xGn_Init (void* CfgPtr)</pre>	
Service ID [hex]	0x01	
Sync/Async	Synchronous	
Reentrancy	Non Reentrant	
Parameters (in)	CfgPtr	Pointer to configuration set
Parameters (inout)	None	
Parameters (out)	None	
Return value	None	
Description	Initializes the V2xGn module.	
Available via	V2xGn.h	

]()[SWS_V2xGn_00133] [

If development error detection is enabled: The function shall check the parameter CfgPtr for containing a valid configuration. If the check fails, the function shall raise the development error V2XGN_E_INIT_FAILED.] ()

8.3.2 V2xGn_GetVersionInfo

[SWS_V2xGn_00069]

Service Name	V2xGn_GetVersionInfo	
Syntax	<pre>void V2xGn_GetVersionInfo (Std_VersionInfoType* VersionInfoPtr)</pre>	
Service ID [hex]	0x02	
Sync/Async	Synchronous	

Reentrancy	Reentrant	
Parameters (in)	None	
Parameters (inout)	None	
Parameters (out)	VersionInfo Ptr	Pointer to where to store the version information of this module.
Return value	None	
Description	Returns the version information of this module.	
Available via	V2xGn.h	

⌋() [SWS_V2xGn_00090] ⌈

If development error detection is enabled: the function shall check the parameter VersionInfoPtr for being valid. If the check fails, the function shall raise the development error V2XGN_E_PARAM_POINTER. ⌋()

8.3.3 V2xGn_V2xM_PreparePseudonymChange

[SWS_V2xGn_00072]⌈

Service Name	V2xGn_V2xM_PreparePseudonymChange	
Syntax	Std_ReturnType V2xGn_V2xM_PreparePseudonymChange (const V2x_PseudonymType* PseudonymPtr)	
Service ID [hex]	0x05	
Sync/Async	Synchronous	
Reentrancy	Non Reentrant	
Parameters (in)	PseudonymPtr	The Pseudonym provided by V2xM
Parameters (inout)	None	
Parameters (out)	None	
Return value	Std_ReturnType	E_OK: operation successful E_NOT_OK: operation failed
Description	This function is called by the V2xM when a Pseudonym Change occurs to prepare the change in every module using it.	
Available via	V2xGn_V2xM.h	

⌋() [SWS_V2xGn_00091] ⌈

The function V2xGn_V2xM_PreparePseudonymChange shall prepare the setting of the pseudonym specific part of the GeoNetworking Address being used for packet transmission.](SRS_V2X_00176)

[SWS_V2xGn_00092] [

If development error detection is enabled: the function shall check that the service V2xGn_Init was previously called. If the check fails, the function shall raise the development error V2XGN_E_UNINIT otherwise (if DET is disabled) return E_NOT_OK.]()

[SWS_V2xGn_00093] [

If development error detection is enabled: the function shall check the parameter PseudonymPtr for being valid. If the check fails, the function shall raise the development error V2XGN_E_PARAM_POINTER otherwise (if DET is disabled) return E_NOT_OK.]()

Note: This starts a module internal transaction for the pseudonym change. The actual pseudonym change becomes effective only after an API call to V2xGn_V2xM_CommitPseudonymChange.

8.3.4 V2xGn_V2xM_CommitPseudonymChange

[SWS_V2xGn_00111] [

Service Name	V2xGn_V2xM_CommitPseudonymChange	
Syntax	Std_ReturnType V2xGn_V2xM_CommitPseudonymChange (void)	
Service ID [hex]	0x09	
Sync/Async	Synchronous	
Reentrancy	Non Reentrant	
Parameters (in)	None	
Parameters (inout)	None	
Parameters (out)	None	
Return value	Std_ReturnType	E_OK: operation successful E_NOT_OK: operation failed
Description	This function is called by the V2xM when all modules are OK with the pseudonym change and the change is to be committed.	
Available via	V2xGn_V2xM.h	

]()[SWS_V2xGn_00112]

The function V2xGn_V2xM_CommitPseudonymChange shall update the pseudonym specific part of the module's GeoNetworking Address.](SRS_V2X_00176)

[SWS_V2xGn_00113] [

If development error detection is enabled: the function shall check that the service V2xGn_Init was previously called. If the check fails, the function shall raise the development error V2XGN_E_UNINIT otherwise (if DET is disabled) return E_NOT_OK.]()

Note: The function requires previous preparation of the pseudonym via an API call to V2xGn_V2xM_PreparePseudonymChange.

8.3.5 V2xGn_V2xM_AbortPseudonymChange

[SWS_V2xGn_00126] [

Service Name	V2xGn_V2xM_AbortPseudonymChange	
Syntax	Std_ReturnType V2xGn_V2xM_AbortPseudonymChange (void)	
Service ID [hex]	0x0a	
Sync/Async	Synchronous	
Reentrancy	Non Reentrant	
Parameters (in)	None	
Parameters (inout)	None	
Parameters (out)	None	
Return value	Std_ReturnType	E_OK: operation successful E_NOT_OK: operation failed
Description	This function is called by the V2xM when not all modules are OK with the pseudonym change and the change is to be rolled back.	
Available via	V2xGn_V2xM.h	

)]()**[SWS_V2xGn_00115]** [

The function V2xGn_V2xM_AbortPseudonymChange shall set the state of the module to the state before the pseudonym change has been prepared.](SRS_V2X_00176)

[SWS_V2xGn_00116] [

If development error detection is enabled: the function shall check that the service V2xGn_Init was previously called. If the check fails, the function shall raise the development error V2XGN_E_UNINIT otherwise (if DET is disabled) return E_NOT_OK.]()

Note: The function requires previous preparation of the pseudonym via an API call to V2xGn_V2xM_PreparePseudonymChange.

8.3.6 V2xGn_Transmit

[SWS_V2xGn_00070]

Service Name	V2xGn_Transmit	
Syntax	<pre>V2x_GnTxResultType V2xGn_Transmit (uint16 TransactionId16, const V2xGn_TxParamsType* TxParams, uint16 Length)</pre>	
Service ID [hex]	0x03	
Sync/Async	Asynchronous	
Reentrancy	Non Reentrant	
Parameters (in)	TransactionId16	Transaction Id for the Packet
	TxParams	Additional transmission parameters
	Length	Length of the user data
Parameters (inout)	None	
Parameters (out)	None	
Return value	V2x_GnTx-ResultType	Values specified in the Type could be returned. V2X_GNTX_ACCEPTED if no error occurred. V2X_GNTX_ACCEPTED transmit has been accepted V2X_GNTX_E_MAXSDUSIZEOVFL transmit has been rejected due to maximum length exceedance V2X_GNTX_E_MAXPACKETLIFETIME transmit has been rejected due to maximum lifetime exceedance V2X_GNTX_E_TCID transmit has been rejected due to unsupported Traffic Class ID V2X_GNTX_E_MAXGEOAREASIZE transmit has been rejected due to GeoArea exceeds max size V2X_GNTX_E_UNSPECIFIED transmit has been rejected due to unspecified reasons
Description	Is called by V2x_Btp to send a message.	
Available via	V2xGn.h	

!() [SWS_V2xGn_00095] [

The function V2xGn_Transmit shall transmit a V2X Packet.]()

[SWS_V2xGn_00096] [

If development error detection is enabled: the function shall check that the service V2xGn_Init was previously called. If the check fails, the function shall raise the development error V2XGN_E_UNINIT otherwise (if DET is disabled) return V2X_GNTX_E_UNSPECIFIED.]()

[SWS_V2xGn_00098] [

The function shall return V2X_GNTX_E_MAXSDUSIZEOVFL if the call to EthIf_ProvideTxBuffer returns BUFREQ_E_OVFL.]()

[SWS_V2xGn_00099] [

The function shall return V2X_GNTX_E_MAXPACKETLIFETIME if the parameter TxParams.maxPacketLifeTime is invalid.]()

[SWS_V2xGn_00100] [

The function shall return V2X_GNTX_E_TCID if the parameter TxParams.trafficClass is invalid.]()

[SWS_V2xGn_00101] [

The function shall return V2X_GNTX_E_MAXGEOAREASIZE if the parameter TxParams.destinationType is V2X_GNDESTINATION_AREA and the parameter TxParams.destinationArea is invalid.]()

8.4 Call-back notifications

8.4.1 This is a list of functions provided for other modules.

V2xGn_V2xM_EncapConfirmation

[SWS_V2xGn_00118] [

Service Name	V2xGn_V2xM_EncapConfirmation	
Syntax	<pre>void V2xGn_V2xM_EncapConfirmation (uint16 TransactionId16)</pre>	
Service ID [hex]	0x0b	
Sync/Async	Asynchronous	
Reentrancy	Non Reentrant	
Parameters (in)	TransactionId16	The TransactionId of the encapsulated packet
Parameters (inout)	None	
Parameters (out)	None	
Return value	None	
Description	This function is called by the V2xM when an encapsulation has been finished.	
Available via	V2xGn_V2xM.h	

]() [SWS_V2xGn_00119] [

The function V2xGn_V2xM_EncapConfirmation shall finalize the packet transmission by transmitting the packet to the lower layer.]()

[SWS_V2xGn_00120] [

If development error detection is enabled: the function shall check that the service V2xGn_Init was previously called. If the check fails, the function shall raise the development error V2XGN_E_UNINIT.]()

Note: The function requires previous successful transmission request via the API V2xGn_Transmit.

8.4.2 V2xGn_V2xM_DecapConfirmation

[SWS_V2xGn_00122] [

Service Name	V2xGn_V2xM_DecapConfirmation	
Syntax	<pre>void V2xGn_V2xM_DecapConfirmation (uint32 TransactionId32, V2xM_SecReportType SecReport, uint64 CertificateId, uint32 ItsAid, uint8 SspLength, uint8* SspBits)</pre>	
Service ID [hex]	0x0c	
Sync/Async	Asynchronous	
Reentrancy	Non Reentrant	
Parameters (in)	Transaction Id32	The TransactionId32 of the decapsulated packet
	SecReport	The security report.
	CertificateId	The identification of the used for verification (by certificate hash)
	ItsAid	The numerical value of the ITS-AID
	SspLength	The length (in octets, up to 31) of the SSP bits
	SspBits	The SSP bits
Parameters (inout)	None	
Parameters (out)	None	
Return value	None	
Description	This function is called by the V2xM when a decapsulation has been finished.	
Available via	V2xGn_V2xM.h	

⌋() [SWS_V2xGn_00123] ⌈

The function V2xGn_V2xM_DecapConfirmation shall continue the processing of a received packet by proceeding with V2xGn protocol operations. ⌋()

[SWS_V2xGn_00124] ⌈

If development error detection is enabled: the function shall check that the service V2xGn_Init was previously called. If the check fails, the function shall raise the development error V2XGN_E_UNINIT. ⌋()

Note: The function requires previous successful reception of a packet via the API V2xGn_RxIndication.

8.4.3 V2xGn_RxIndication

[SWS_V2xGn_00071] ⌈

Service Name	V2xGn_RxIndication	
Syntax	<pre>void V2xGn_RxIndication (uint8 CtrlIdx, Eth_FrameType FrameType, boolean IsBroadcast, const uint8* PhysAddrPtr, uint8* DataPtr, uint16 LenByte)</pre>	
Service ID [hex]	0x04	
Sync/Async	Synchronous	
Reentrancy	Non Reentrant	
Parameters (in)	CtrlIdx	Index of the Ethernet controller within the context of the Ethernet Interface
	FrameType	frame type of received Ethernet frame
	Is Broadcast	parameter to indicate a broadcast frame
	PhysAddr Ptr	pointer to Physical source address (MAC address in network byte order) of received Ethernet frame
	DataPtr	Pointer to payload of the received Ethernet frame (i.e. Ethernet header is not provided).
	LenByte	Length of received data.
Parameters (inout)	None	
Parameters (out)	None	
Return value	None	

Description	Indicates the reception of an Ethernet frame
Available via	V2xGn.h

[SWS_V2xGn_00103] [

The function V2xGn_RxIndication shall get reception parameters of the Wireless Ethernet Driver for a V2X Packet received via an API call to EthIf_GetBufWRxParams.]()

This is done to get access to the wireless specific reception parameters (e.g. the RSSI or the TransactionId32) of the packet that is not available through the V2xGn_RxIndication API.

[SWS_V2xGn_00104] [

If development error detection is enabled: the function shall check that the service V2xGn_Init was previously called. If the check fails, the function shall raise the development error V2XGN_E_UNINIT.]()

[SWS_V2xGn_00105] [

If development error detection is enabled: the function shall check the parameter DataPtr for being valid. If the check fails, the function shall raise the development error V2XGN_E_PARAM_POINTER.]()

8.4.4 V2xGn_TxConfirmation

[SWS_V2xGn_00074][

Service Name	V2xGn_TxConfirmation	
Syntax	<pre>void V2xGn_TxConfirmation (uint8 CtrlIdx, uint8 BufIdx)</pre>	
Service ID [hex]	0x07	
Sync/Async	Synchronous	
Reentrancy	Non Reentrant	
Parameters (in)	Ctrl Idx	Index of the Ethernet controller within the context of the Ethernet Interface
	Buf Idx	Index of the buffer resource
Parameters (inout)	None	
Parameters (out)	None	
Return value	None	
Description	Confirms the transmission of an Ethernet frame	

Available via	V2xGn.h
----------------------	---------

]() [SWS_V2xGn_00107] [

If development error detection is enabled: the function shall check that the service V2xGn_Init was previously called. If the check fails, the function shall raise the development error V2XGN_E_UNINIT.]()

8.5 Scheduled functions

8.5.1 V2xGn_MainFunction

[SWS_V2xGn_00075] [

Service Name	V2xGn_MainFunction
Syntax	void V2xGn_MainFunction (void)
Service ID [hex]	0x08
Description	Main function of the V2xGn module for periodical execution of protocol operations.
Available via	SchM_V2xGn.h

]()

8.6 Expected Interfaces

In this chapter all external interfaces required from other modules are listed.

8.6.1 Mandatory Interfaces

This chapter defines all external interfaces which are required to fulfill the core functionality of the module.

[SWS_V2xGn_00076] [

API Function	Header File	Description
EthIf_GetBufWRx-Params	EthIf.h	Read out values related to the receive direction of the transceiver for a received packet. For example, this could be RSSI or Channel belonging to one single packet.
EthIf_GetBufWTx-Params	EthIf.h	Read out values related to the transmit direction of the transceiver for a transmitted packet. For example, this could be transaction ID belonging to one single packet.
EthIf_ProvideTx-	EthIf.h	Provides access to a transmit buffer of the specified Ethernet

Buffer		controller.
EthIf_SetBufWTx-Params	EthIf.h	Set values related to the transmit direction of the transceiver for a specific buffer (packet to be sent). For example, this can be the desired transmit power or the channel belonging to one single packet.
EthIf_Transmit	EthIf.h	Triggers transmission of a previously filled transmit buffer
V2xBtp_CopyTx-Data	V2xBtp.h	This API is called by the V2xGn module to request the V2xBtp module to copy the transmission data to a specific location.
V2xBtp_Rx-Indication	V2xBtp.h	Via this API, the V2xBtp module gets the data (BTP-PDU), the Geo Networking parameters and the Transaction ID of a received Geo Networking packet.
V2xM_Calc-Distance	V2xM.h	Calculates the distance between two geographical points on earth with the assumption that they are on elevation 0.
V2xM_Get-PositionAndTime	V2xM.h	Provides the instantaneous position information.
V2xM_GetRef-TimePtr	V2xM.h	Provides a pointer to the time reference of the V2X-Stack.
V2xM_Trigger-Pseudonym-Change	V2xM.h	This function is called by the V2xFac, V2xGn or another entity to change the Pseudonym used by the V2X-Stack, e.g. due to a Geo Networking address conflict.
V2xM_V2xGn_-GetGlobalTx-Params	V2xM_V2xGn.h	This function is called by V2xGn to get the current channel busy percentage for the specified channel
V2xM_V2xGn_-ReqDecap	V2xM_V2xGn.h	This function is called by the V2xGn to decrypt and verify a message. An asynchronous V2xGn_V2xM_DecapConfirmation call will be used to notify V2xGn of the result.
V2xM_V2xGn_-ReqEncap	V2xM_V2xGn.h	This function is called by the V2xGn to sign and/or encrypt a message. An asynchronous V2xGn_V2xM_EncapConfirmation call will be used to notify V2xGn of the result.
V2xM_V2xGn_-SetGlobalRx-Params	V2xM_V2xGn.h	This function is called by V2xGn to set the current channel busy percentage for the specified channel

()

8.6.2 Optional Interfaces

This chapter defines all external interfaces which are required to fulfill an optional functionality of the module.

[SWS_V2xGn_00077]

API Function	Header File	Description
Det_ReportError	Det.h	Service to report development errors.

V2xBtp_Tx-Confirmation	V2xBtp.h	By this API primitive, the V2xBtp module gets an indication from the V2xGn module about the status of the transmission of the data (FAC-PDU) with the associated ID.
------------------------	----------	--

J()

9 Sequence diagrams

The following sequence diagrams show the interactions between the V2xGn module and its adjacent modules.

Please note that the sequence diagrams are an extension for illustrational purposes to ease understanding of the specification and to support the functional specification described in chapter 7 and API specification described in chapter 8.

Note that all parameters and return types are left out to make the diagrams easier to read and understand.

9.1 V2xGn_RxIndication

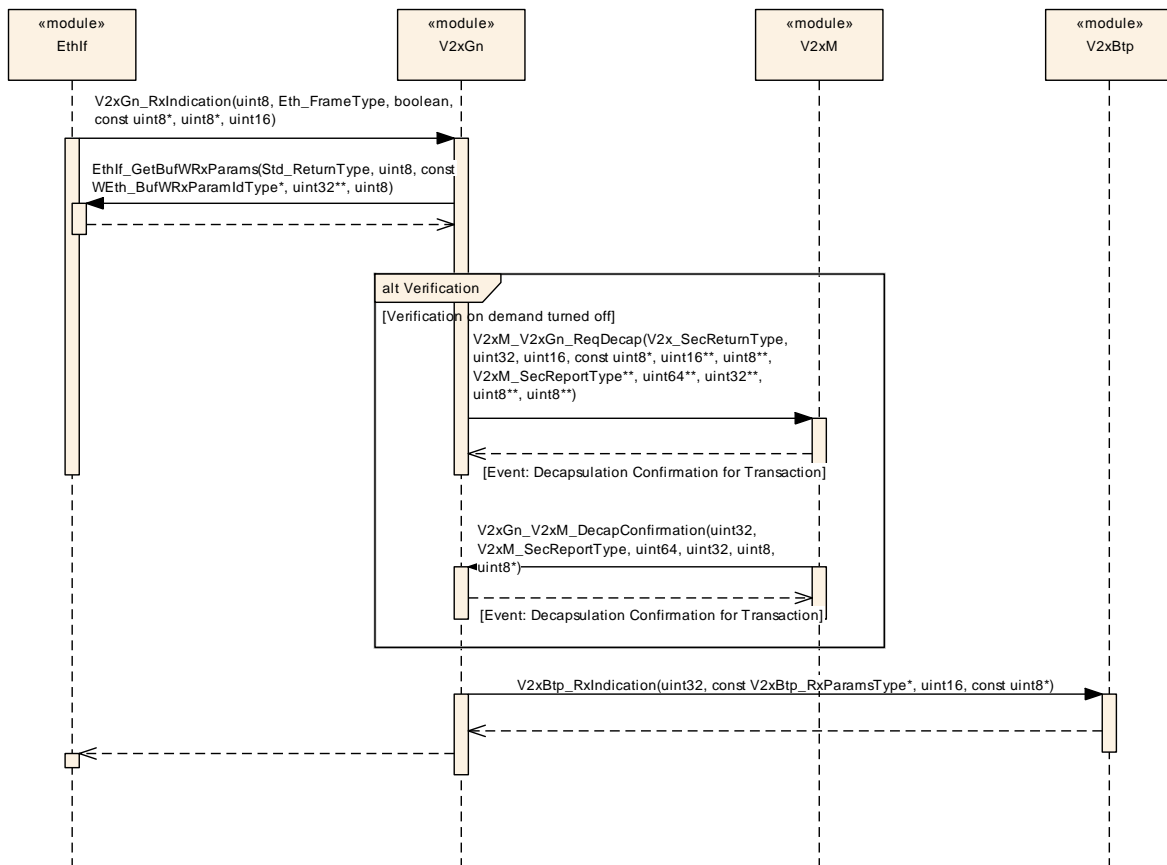

Figure 2 –V2xGn_RxIndication

9.2 V2xGn_Transmit

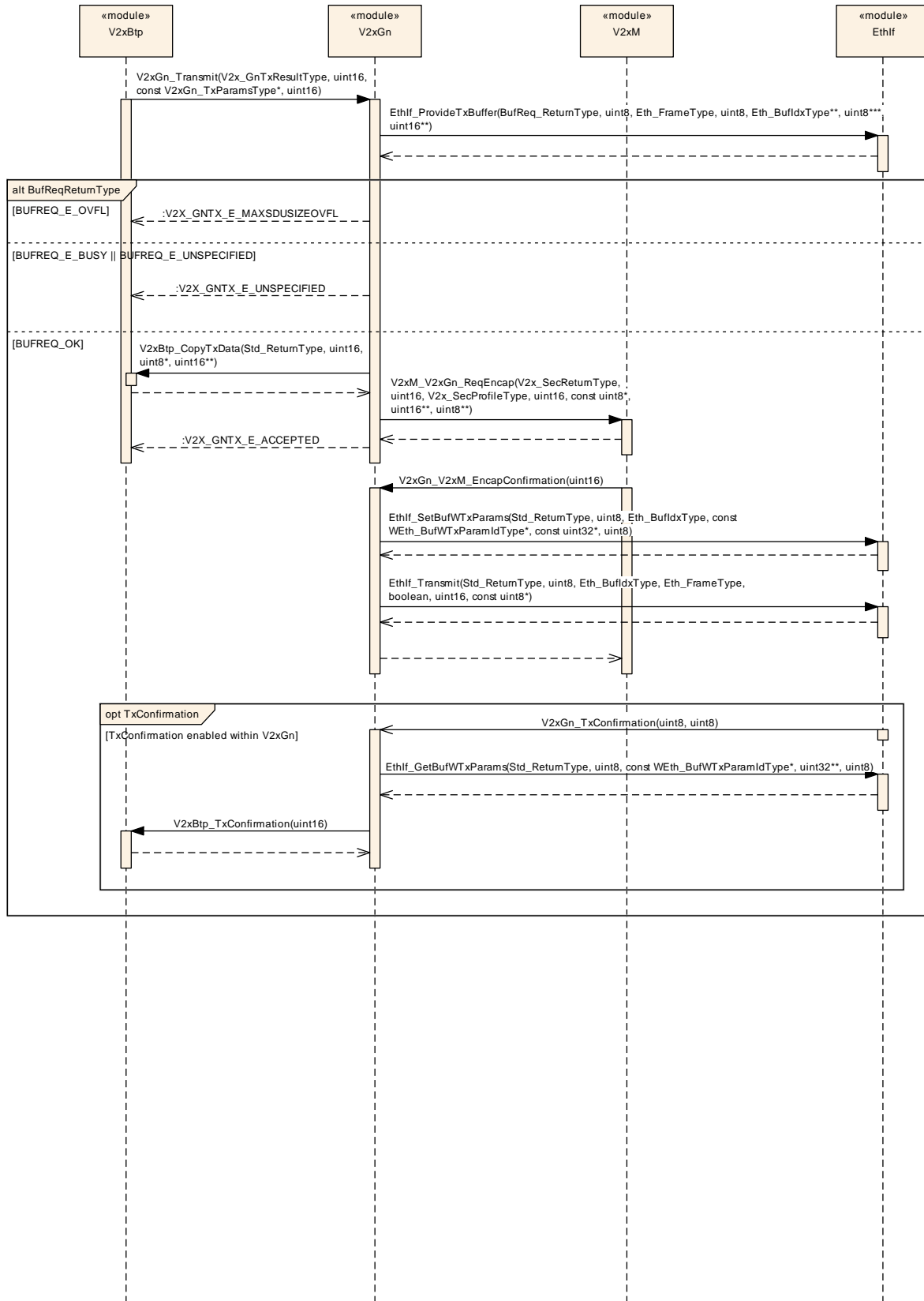

Figure 3 – V2xGn_Transmit

9.3 V2xGn_V2xM_UpdatePseudonym

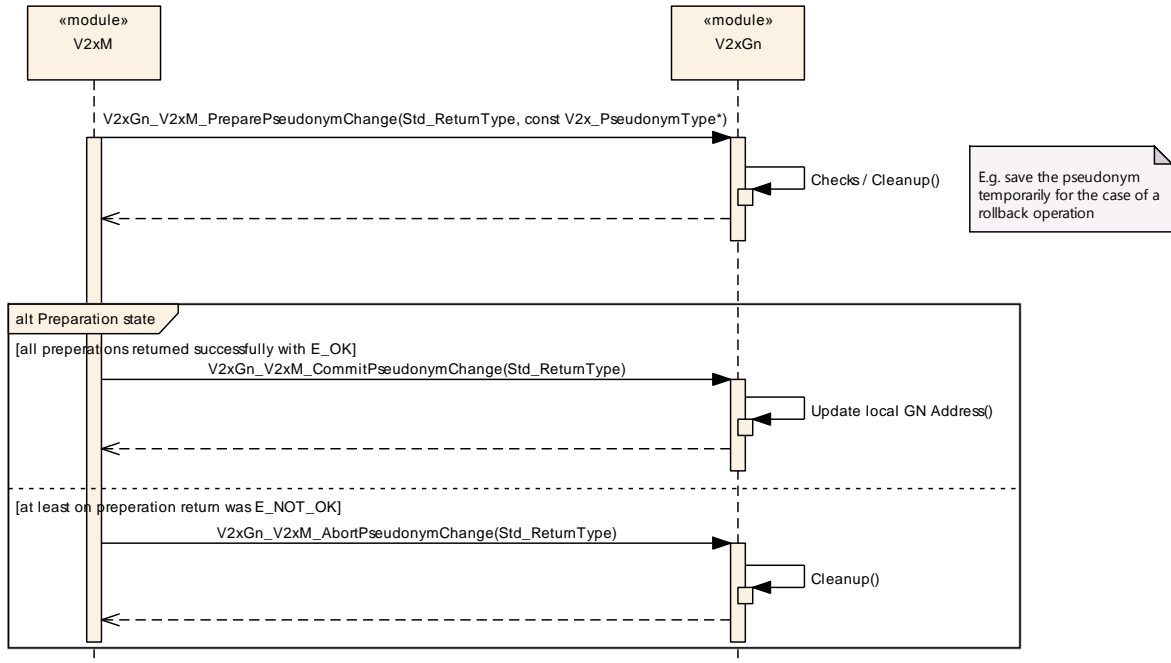

Figure 4 – V2xGn_V2xM_UpdatePseudonym

9.4 V2xGn_MainFunction

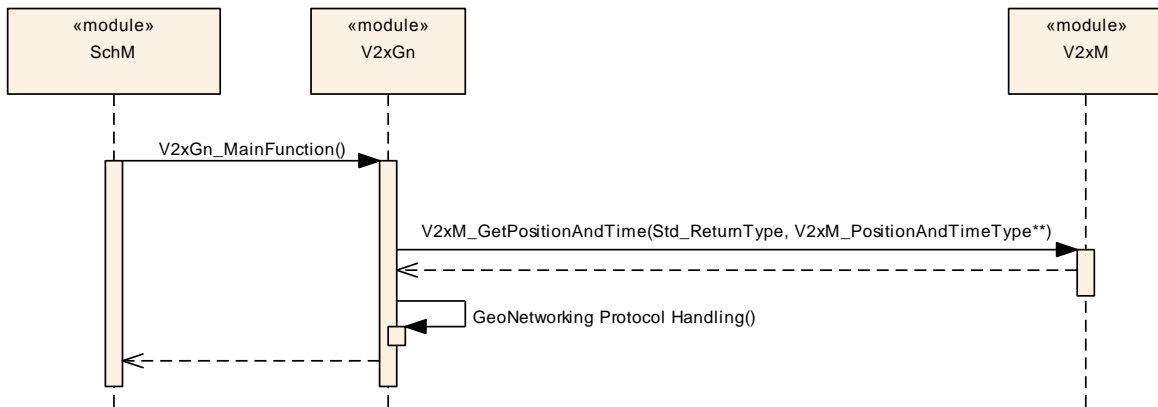

Figure 5 – V2xGn_MainFunction

10 Configuration specification

Chapter 10.1 specifies the structure (containers) and the parameters of the module V2xGn.

Chapter 0 specifies additionally published information of the module V2xGn.

10.1 Containers and configuration parameters

The following chapters summarize all configuration parameters. The detailed meanings of the parameters are described in chapter 7 and chapter 8.

10.1.1 Variants

[SWS_V2xGn_00078] | The V2xGn module only supports VARIANT-PRE-COMPILE | (SRS_BSW_00345)

10.1.2 V2xGn

SWS Item	ECUC_V2xGn_00001 :
Module Name	V2xGn
Module Description	Configuration of the V2xGn (Vehicle-2-X Geo Networking) module.
Post-Build Variant Support	false
Supported Config Variants	VARIANT-PRE-COMPILE

Included Containers		
Container Name	Multiplicity	Scope / Dependency
V2xGnBeaconService	1	This container contains the GeoNetworking configuration parameters related to the beacon service.
V2xGnGeneral	1	This container specifies the general configuration parameters of the V2xGn module.
V2xGnPacketForwarding	1	This container contains the GeoNetworking configuration parameters related to packet forwarding.

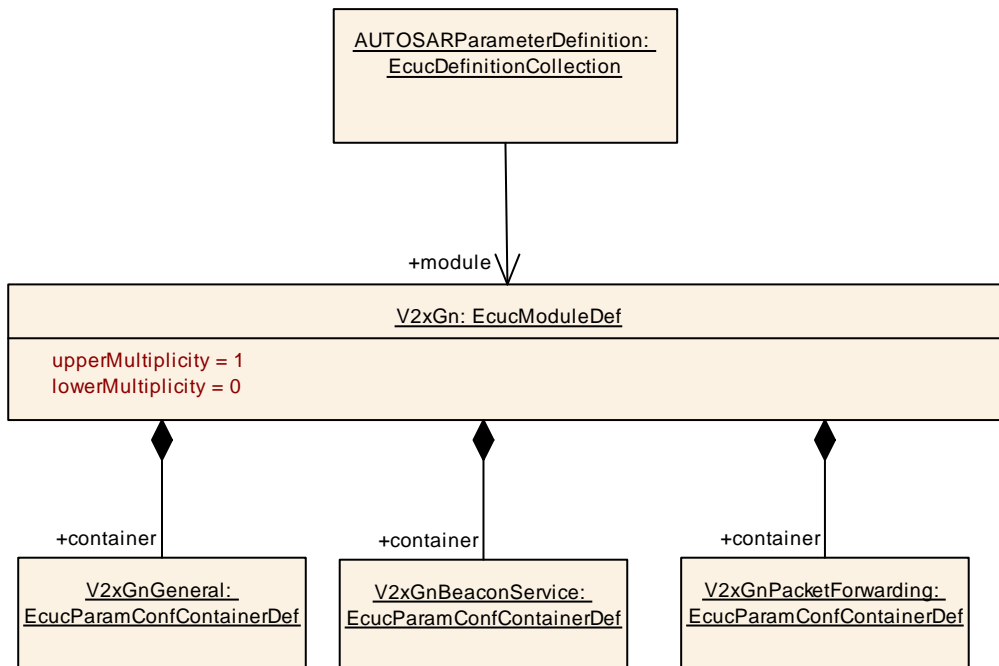

10.1.3 V2xGnGeneral

SWS Item	ECUC_V2xGn_00002 :
Container Name	V2xGnGeneral
Parent Container	V2xGn
Description	This container specifies the general configuration parameters of the V2xGn module.
Configuration Parameters	

SWS Item	ECUC_V2xGn_00006 :									
Name	V2xGnDevErrorDetect									
Parent Container	V2xGnGeneral									
Description	Switches the Default Error Tracer (Det) detection and notification ON or OFF. <ul style="list-style-type: none"> ▪ true: enabled (ON) ▪ false: disabled (OFF) 									
Multiplicity	1									
Type	EcucBooleanParamDef									
Default value	false									
Post-Build Variant Value	false									
Value Configuration Class	<table border="1"> <tr> <td>Pre-compile time</td> <td>X</td> <td>All Variants</td> </tr> <tr> <td>Link time</td> <td>--</td> <td></td> </tr> <tr> <td>Post-build time</td> <td>--</td> <td></td> </tr> </table>	Pre-compile time	X	All Variants	Link time	--		Post-build time	--	
Pre-compile time	X	All Variants								
Link time	--									
Post-build time	--									
Scope / Dependency	scope: local									

SWS Item	ECUC_V2xGn_00016 :
Name	V2xGnItsGnLifetimeLocTE
Parent Container	V2xGnGeneral
Description	Location table maintenance: Lifetime of an entry in the location table in [s]
Multiplicity	1

Type	EcucFloatParamDef		
Range	[0 .. 65535]		
Default value	20		
Post-Build Variant Value	false		
Value Configuration Class	Pre-compile time	X	All Variants
	Link time	--	
	Post-build time	--	
Scope / Dependency	scope: local dependency: shall be a multiple of the V2xGnMainFunctionPeriod		

SWS Item	ECUC_V2xGn_00009 :		
Name	V2xGnItsGnLocalGnAddr		
Parent Container	V2xGnGeneral		
Description	64bit GeoNetworking Address.		
Multiplicity	1		
Type	EcucIntegerParamDef		
Range	0 .. 18446744073709551615		
Default value	1		
Post-Build Variant Value	false		
Value Configuration Class	Pre-compile time	X	All Variants
	Link time	--	
	Post-build time	--	
Scope / Dependency	scope: local		

SWS Item	ECUC_V2xGn_00014 :		
Name	V2xGnItsGnMaxGeoNetworkingHeaderSize		
Parent Container	V2xGnGeneral		
Description	Maximum size of GeoNetworking header in [Byte].		
Multiplicity	1		
Type	EcucIntegerParamDef		
Range	0 .. 65535		
Default value	88		
Post-Build Variant Value	false		
Value Configuration Class	Pre-compile time	X	All Variants
	Link time	--	
	Post-build time	--	
Scope / Dependency	scope: local		

SWS Item	ECUC_V2xGn_00013 :		
Name	V2xGnItsGnMaxSduSize		
Parent Container	V2xGnGeneral		
Description	Maximum size of GN-SDU in [Byte].		
Multiplicity	1		
Type	EcucIntegerParamDef		
Range	0 .. 65535		
Default value	1398		
Post-Build Variant Value	false		
Value Configuration Class	Pre-compile time	X	All Variants
	Link time	--	
	Post-build time	--	
Scope / Dependency	scope: local		

SWS Item	ECUC_V2xGn_00011 :		
Name	V2xGnItsGnMinUpdateFrequencyEPV		
Parent Container	V2xGnGeneral		

Description	Minimum update frequency of ego position vector (EPV) in [s].		
Multiplicity	1		
Type	EcucFloatParamDef		
Range	[0 .. 65535]		
Default value	--		
Post-Build Variant Value	false		
Value Configuration Class	Pre-compile time	X	All Variants
	Link time	--	
	Post-build time	--	
Scope / Dependency	scope: local dependency: shall be a multiple of the V2xGnMainFunctionPeriod		

SWS Item	ECUC_V2xGn_00012 :		
Name	V2xGnItsGnPaiInterval		
Parent Container	V2xGnGeneral		
Description	Distance related to the confidence interval for latitude and longitude [m]. Used to determine the PAI.		
Multiplicity	1		
Type	EcucIntegerParamDef		
Range	0 .. 100		
Default value	80		
Post-Build Variant Value	false		
Value Configuration Class	Pre-compile time	X	All Variants
	Link time	--	
	Post-build time	--	
Scope / Dependency	scope: local		

SWS Item	ECUC_V2xGn_00008 :		
Name	V2xGnItsGnProtocolVersion		
Parent Container	V2xGnGeneral		
Description	GeoNetworking protocol version as defined in Annex H of [14]		
Multiplicity	1		
Type	EcucIntegerParamDef		
Range	0 .. 255		
Default value	1		
Post-Build Variant Value	false		
Value Configuration Class	Pre-compile time	X	All Variants
	Link time	--	
	Post-build time	--	
Scope / Dependency	scope: local		

SWS Item	ECUC_V2xGn_00017 :		
Name	V2xGnItsGnSnDecapResultHandling		
Parent Container	V2xGnGeneral		
Description	Indicates the handling of the V2xM_ReqDecap result code.		
Multiplicity	1		
Type	EcucEnumerationParamDef		
Range	V2XGN_NON_STRICT_SEC_HANDLING		GN packets that are not correctly verified and decrypted can be passed to the upper protocol entity for further processing.
	V2XGN_STRICT_SEC_HANDLING		Received GN packets that are not correctly verified and decrypted are always dropped.
Post-Build	false		

Variant Value			
Value Configuration Class	Pre-compile time	X	All Variants
	Link time	--	
	Post-build time	--	
Scope / Dependency	scope: local		

SWS Item	ECUC_V2xGn_00015 :		
Name	V2xGnItsGnStationType		
Parent Container	V2xGnGeneral		
Description	Station Type used in GeoNetworking protocol, RoadSideUnit (15) not supported by AUTOSAR.		
Multiplicity	1		
Type	EcucEnumerationParamDef		
Range	V2XFAC_ST_BUS	--	
	V2XFAC_ST_CYCLIST	--	
	V2XFAC_ST_HEAVYTRUCK	--	
	V2XFAC_ST_LIGHTTRUCK	--	
	V2XFAC_ST_MOPED	--	
	V2XFAC_ST_MOTORCYCLE	--	
	V2XFAC_ST_PASSENGERCAR	--	
	V2XFAC_ST_PEDESTRIAN	--	
	V2XFAC_ST_SPECIALVEHICLES	--	
	V2XFAC_ST_TRAILER	--	
	V2XFAC_ST_TRAM	--	
	V2XFAC_ST_UNKNOWN	--	
Post-Build Variant Value	false		
Value Configuration Class	Pre-compile time	X	All Variants
	Link time	--	
	Post-build time	--	
Scope / Dependency	scope: local		

SWS Item	ECUC_V2xGn_00018 :		
Name	V2xGnMainFunctionPeriod		
Parent Container	V2xGnGeneral		
Description	Specifies the period of main function V2xGn_MainFunction in seconds. V2xGn does not require this information but the BSW scheduler.		
Multiplicity	1		
Type	EcucFloatParamDef		
Range]0 .. INF[
Default value	0.001		
Post-Build Variant Value	false		
Value Configuration Class	Pre-compile time	X	All Variants
	Link time	--	
	Post-build time	--	
Scope / Dependency	scope: local		

SWS Item	ECUC_V2xGn_00007 :		
Name	V2xGnTxConfirmation		
Parent Container	V2xGnGeneral		
Description	When enabled, transmission status information will be forwarded to the upper layer. <ul style="list-style-type: none"> ▪ true: enabled (ON) 		

	<ul style="list-style-type: none"> false: disable (OFF) 		
Multiplicity	1		
Type	EcucBooleanParamDef		
Default value	false		
Post-Build Variant Value	false		
Value Configuration Class	Pre-compile time	X	All Variants
	Link time	--	
	Post-build time	--	
Scope / Dependency	scope: ECU		

SWS Item	ECUC_V2xGn_00005 :		
Name	V2xGnVersionInfoApi		
Parent Container	V2xGnGeneral		
Description	Enable/disables the API for reading the version information of the V2xGn Module. <ul style="list-style-type: none"> true: enabled (ON) false: disabled (OFF) 		
Multiplicity	1		
Type	EcucBooleanParamDef		
Default value	false		
Post-Build Variant Value	false		
Value Configuration Class	Pre-compile time	X	All Variants
	Link time	--	
	Post-build time	--	
Scope / Dependency	scope: local		

SWS Item	ECUC_V2xGn_00019 :		
Name	V2xGnEthIfRef		
Parent Container	V2xGnGeneral		
Description	This represents the reference to the Ethernet interface taken to transmit the V2X-Packets to.		
Multiplicity	1		
Type	Symbolic name reference to [EthIfController]		
Post-Build Variant Value	false		
Value Configuration Class	Pre-compile time	X	All Variants
	Link time	--	
	Post-build time	--	
Scope / Dependency	scope: local		

No Included Containers

10.1.4 V2xGnBeaconService

SWS Item	ECUC_V2xGn_00003 :
Container Name	V2xGnBeaconService
Parent Container	V2xGn
Description	This container contains the GeoNetworking configuration parameters related to the beacon service.
Configuration Parameters	

SWS Item	ECUC_V2xGn_00021 :		
Name	V2xGnItsGnBeaconServiceMaxJitter		
Parent Container	V2xGnBeaconService		
Description	Maximum beacon jitter [s]. The Jitter is used for the beacon retransmission. The actual jitter value is a random number between 0 and V2xGnItsGnBeaconServiceMaxJitter. The function introduces a random component for the timer to avoid synchronization issues among GeoAdhoc routers.		
Multiplicity	1		
Type	EcucFloatParamDef		
Range	[0.001 .. INF]		
Default value	0.75		
Post-Build Variant Value	false		
Value Configuration Class	Pre-compile time	X	All Variants
	Link time	--	
	Post-build time	--	
Scope / Dependency	scope: local		

SWS Item	ECUC_V2xGn_00020 :		
Name	V2xGnItsGnBeaconServiceRetransmitTimer		
Parent Container	V2xGnBeaconService		
Description	Duration of Beacon service retransmit timer [s].		
Multiplicity	1		
Type	EcucFloatParamDef		
Range	[0.001 .. INF]		
Default value	3		
Post-Build Variant Value	false		
Value Configuration Class	Pre-compile time	X	All Variants
	Link time	--	
	Post-build time	--	
Scope / Dependency	scope: local		
	dependency: shall be a multiple of the V2xGnMainFunctionPeriod.		

No Included Containers

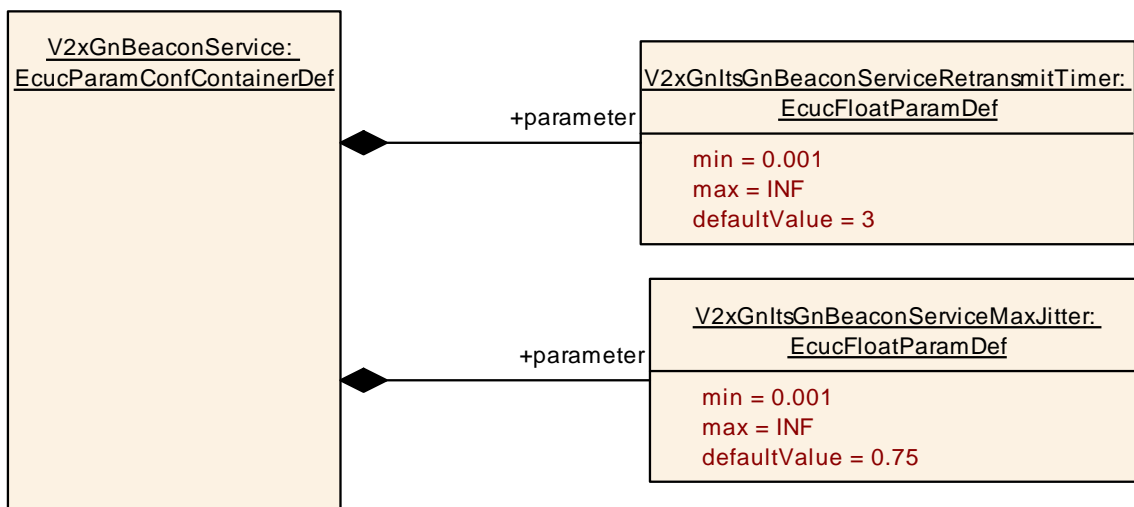

10.1.5 V2xGnPacketForwarding

SWS Item	ECUC_V2xGn_00004 :
Container Name	V2xGnPacketForwarding
Parent Container	V2xGn
Description	This container contains the GeoNetworking configuration parameters related to packet forwarding.
Configuration Parameters	

SWS Item	ECUC_V2xGn_00032 :		
Name	V2xGnItsGnBcForwardingPacketBufferSize		
Parent Container	V2xGnPacketForwarding		
Description	Size of BC forwarding packet buffer [Byte].		
Multiplicity	1		
Type	EcucIntegerParamDef		
Range	0 ..	18446744073709551615	
Default value	1024000		
Post-Build Variant Value	false		
Value Configuration Class	Pre-compile time	X	All Variants
	Link time	--	
	Post-build time	--	
Scope / Dependency	scope: local		

SWS Item	ECUC_V2xGn_00029 :		
Name	V2xGnItsGnCbfMaxTime		
Parent Container	V2xGnPacketForwarding		
Description	Maximum duration a GeoNetworking packet shall be buffered in the CBF packet buffer [s]		
Multiplicity	1		
Type	EcucFloatParamDef		
Range]0 .. INF[
Default value	0.001		
Post-Build Variant Value	false		
Value Configuration Class	Pre-compile time	X	All Variants
	Link time	--	

	Post-build time	--	
Scope / Dependency	scope: local		

SWS Item	ECUC_V2xGn_00028 :		
Name	V2xGnItsGnCbfMinTime		
Parent Container	V2xGnPacketForwarding		
Description	Minimum duration a GeoNetworking packet shall be buffered in the CBF packet buffer [s]		
Multiplicity	1		
Type	EcucFloatParamDef		
Range]0 .. INF[
Default value	0.001		
Post-Build Variant Value	false		
Value Configuration Class	Pre-compile time	X	All Variants
	Link time	--	
	Post-build time	--	
Scope / Dependency	scope: local		

SWS Item	ECUC_V2xGn_00033 :		
Name	V2xGnItsGnCbfPacketBufferSize		
Parent Container	V2xGnPacketForwarding		
Description	Size of CBF packet buffer [Byte]		
Multiplicity	1		
Type	EcuIntegerParamDef		
Range	0 .. 18446744073709551615		
Default value	256000		
Post-Build Variant Value	false		
Value Configuration Class	Pre-compile time	X	All Variants
	Link time	--	
	Post-build time	--	
Scope / Dependency	scope: local		

SWS Item	ECUC_V2xGn_00022 :		
Name	V2xGnItsGnDefaultHopLimit		
Parent Container	V2xGnPacketForwarding		
Description	Default hop limit indicating the maximum number of hops a packet travels.		
Multiplicity	1		
Type	EcuIntegerParamDef		
Range	0 .. 255		
Default value	10		
Post-Build Variant Value	false		
Value Configuration Class	Pre-compile time	X	All Variants
	Link time	--	
	Post-build time	--	
Scope / Dependency	scope: local		

SWS Item	ECUC_V2xGn_00030 :		
Name	V2xGnItsGnDefaultMaxCommunicationRange		
Parent Container	V2xGnPacketForwarding		
Description	Default theoretical maximum communication range [m]		
Multiplicity	1		
Type	EcuIntegerParamDef		
Range	0 .. 65535		
Default value	1000		
Post-Build Variant Value	false		

Value Configuration Class	Pre-compile time	X	All Variants
	Link time	--	
	Post-build time	--	
Scope / Dependency	scope: local		

SWS Item	ECUC_V2xGn_00024 :		
Name	V2xGnItsGnDefaultPacketLifetime		
Parent Container	V2xGnPacketForwarding		
Description	Default packet lifetime [s].		
Multiplicity	1		
Type	EcucFloatParamDef		
Range	[0 .. 6300]		
Default value	60		
Post-Build Variant Value	false		
Value Configuration Class	Pre-compile time	X	All Variants
	Link time	--	
	Post-build time	--	
Scope / Dependency	scope: local		

SWS Item	ECUC_V2xGn_00034 :		
Name	V2xGnItsGnDefaultTrafficClass		
Parent Container	V2xGnPacketForwarding		
Description	Forwarding: Default traffic class		
Multiplicity	1		
Type	EcucIntegerParamDef		
Range	0 .. 255		
Default value	0		
Post-Build Variant Value	false		
Value Configuration Class	Pre-compile time	X	All Variants
	Link time	--	
	Post-build time	--	
Scope / Dependency	scope: local		

SWS Item	ECUC_V2xGn_00035 :		
Name	V2xGnItsGnDplLength		
Parent Container	V2xGnPacketForwarding		
Description	Length of Duplicate Packet List (DPL) per source (clause A.2 of [18])		
Multiplicity	1		
Type	EcucIntegerParamDef		
Range	0 .. 65535		
Default value	8		
Post-Build Variant Multiplicity	true		
Multiplicity Configuration Class	Pre-compile time	X	All Variants
	Link time	--	
	Post-build time	--	
Scope / Dependency	scope: local		

SWS Item	ECUC_V2xGn_00031 :		
Name	V2xGnItsGnGeoAreaLineForwardingUsed		
Parent Container	V2xGnPacketForwarding		
Description	Forwarding of GBC/GAC packet if GeoAdhoc router is located outside the destination GeoArea. <ul style="list-style-type: none"> ▪ true: enabled (ON) 		

	<ul style="list-style-type: none"> false: disabled (OFF) 		
Multiplicity	1		
Type	EcucBooleanParamDef		
Default value	false		
Post-Build Variant Value	false		
Value Configuration Class	Pre-compile time	X	All Variants
	Link time	--	
	Post-build time	--	
Scope / Dependency	scope: local		

SWS Item	ECUC_V2xGn_00027 :		
Name	V2xGnItsGnMaxGeoAreaSize		
Parent Container	V2xGnPacketForwarding		
Description	Maximum size of the geographical area for a GBC and GAC packet [km2]. If the geographical area size exceeds the maximum value, the GeoNetworking packet shall not be sent (source) and not be forwarded (forwarder).		
Multiplicity	1		
Type	EcucIntegerParamDef		
Range	0 .. 18446744073709551615		
Default value	80		
Post-Build Variant Value	false		
Value Configuration Class	Pre-compile time	X	All Variants
	Link time	--	
	Post-build time	--	
Scope / Dependency	scope: local		

SWS Item	ECUC_V2xGn_00025 :		
Name	V2xGnItsGnMaxPacketDataRate		
Parent Container	V2xGnPacketForwarding		
Description	Maximum packet data rate for a GeoAdhoc router [Byte/s]. If the mean (EMA) packet data rate a of a GeoAdhoc router exceeds the value, packets from this GeoAdhoc router (source or sender) are not forwarded.		
Multiplicity	1		
Type	EcucIntegerParamDef		
Range	0 .. 4294967295		
Default value	100000		
Post-Build Variant Value	false		
Value Configuration Class	Pre-compile time	X	All Variants
	Link time	--	
	Post-build time	--	
Scope / Dependency	scope: local		

SWS Item	ECUC_V2xGn_00026 :		
Name	V2xGnItsGnMaxPacketDataRateEmaBeta		
Parent Container	V2xGnPacketForwarding		
Description	Weight factor for the Exponential Moving Average of the packet data rate PDR in percent.		
Multiplicity	1		
Type	EcucFloatParamDef		
Range]0 .. 1]		
Default value	0.9		
Post-Build Variant Value	false		
Value Configuration Class	Pre-compile time	X	All Variants

	Link time	--	
	Post-build time	--	
Scope / Dependency	scope: local		

SWS Item	ECUC_V2xGn_00023 :		
Name	V2xGnItsGnMaxPacketLifetime		
Parent Container	V2xGnPacketForwarding		
Description	Upper limit of the maximum lifetime [s]		
Multiplicity	1		
Type	EcucFloatParamDef		
Range	[0 .. 6300]		
Default value	600		
Post-Build Variant Value	false		
Value Configuration Class	Pre-compile time	X	All Variants
	Link time	--	
	Post-build time	--	
Scope / Dependency	scope: local		

No Included Containers

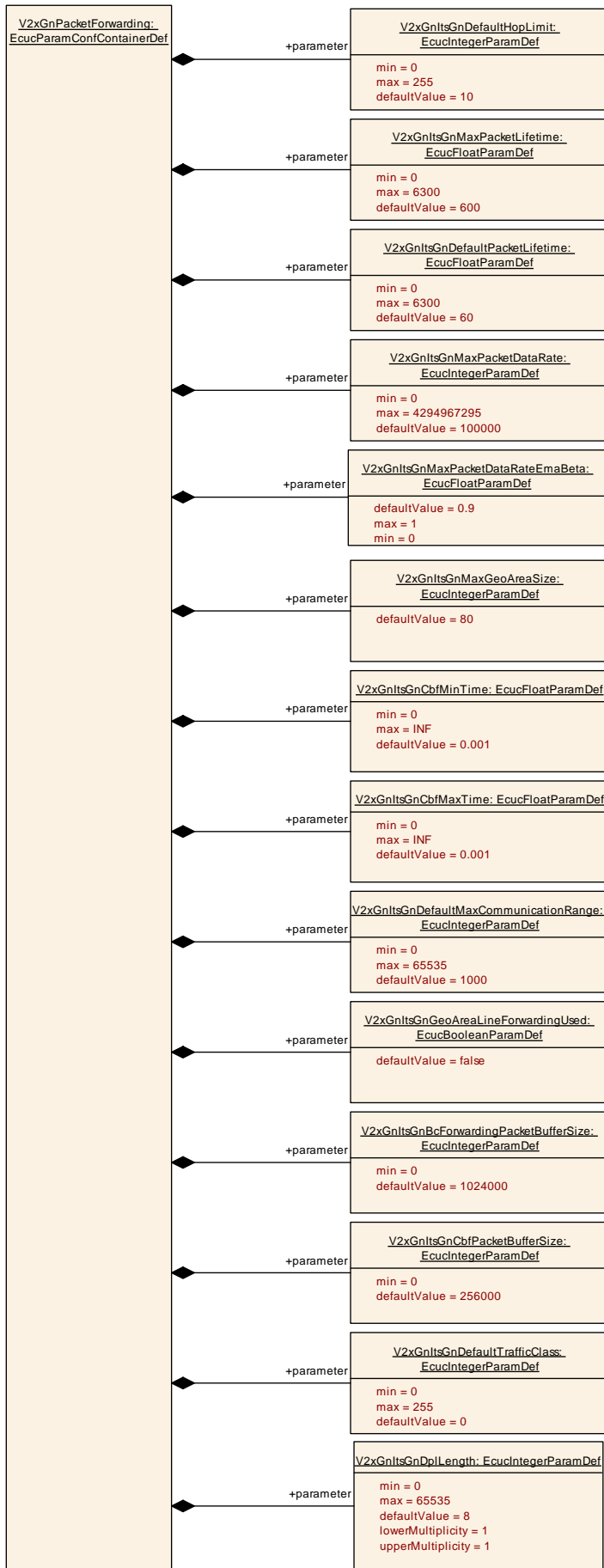

10.2 Published Information

For details refer to the chapter 10.3 “Published Information” in [3].

11 Not applicable requirements

[SWS_V2xGn_NA_1] | This requirement references all not applicable access layer requirements | (SRS_V2X_00451, SRS_V2X_00322, SRS_V2X_00242, SRS_V2X_00391, SRS_V2X_00232, SRS_V2X_00245, SRS_V2X_00239)

[SWS_V2xGn_NA_2] | This requirement references all not applicable facility layer requirements | (SRS_V2X_00711, SRS_V2X_00291, SRS_V2X_00318, SRS_V2X_00741, SRS_V2X_00301)

[SWS_V2xGn_NA_3] | This requirement references all not applicable security requirements | (SRS_V2X_00405, SRS_V2X_00413, SRS_V2X_00163, SRS_V2X_00412, SRS_V2X_00407, SRS_V2X_00406, SRS_V2X_00184, SRS_V2X_00174)

[SWS_V2xGn_NA_4] | This requirement references all not applicable other requirements from SRS V2X | (SRS_V2X_00190, SRS_V2X_00193, SRS_V2X_00207, SRS_V2X_00214, SRS_V2X_00693, SRS_V2X_00189, SRS_V2X_00323, SRS_V2X_00511)