

<b>Document Title</b>	Specification of Flash Driver
<b>Document Owner</b>	AUTOSAR
<b>Document Responsibility</b>	AUTOSAR
<b>Document Identification No</b>	25
<b>Document Status</b>	published
<b>Part of AUTOSAR Standard</b>	Classic Platform
<b>Part of Standard Release</b>	R19-11

<b>Document Change History</b>			
<b>Date</b>	<b>Release</b>	<b>Changed by</b>	<b>Change Description</b>
2019-11-28	R19-11	AUTOSAR Release Management	<ul style="list-style-type: none"> <li>• Draft status of ECUC_Fls_00323 removed</li> <li>• Changed Document Status from Final to published</li> </ul>
2018-10-31	4.4.0	AUTOSAR Release Management	<ul style="list-style-type: none"> <li>• Added support for MCALMulticoreDistribution</li> </ul>
2017-12-08	4.3.1	AUTOSAR Release Management	<ul style="list-style-type: none"> <li>• Removed references to HIS</li> <li>• Renamed "default error" to "development error"</li> <li>• Introduction of runtime errors</li> <li>• Configuration of instance ID for instantiated modules</li> </ul>
2016-11-30	4.3.0	AUTOSAR Release Management	<ul style="list-style-type: none"> <li>• Updated tracing information</li> <li>• Internal buffer alignment clarified</li> <li>• Error handling refined, new configuration parameters added</li> </ul>
2015-07-31	4.2.2	AUTOSAR Release Management	<ul style="list-style-type: none"> <li>• Debugging support marked as obsolete</li> <li>• Error classification reworked</li> <li>• Reference to DEM removed</li> <li>• Description for configuration parameter FlsUseInterrupts clarified</li> </ul>
2014-10-31	4.2.1	AUTOSAR Release Management	<ul style="list-style-type: none"> <li>• Requirements linked to features and BSW requirements.</li> </ul>
2014-03-31	4.1.3	AUTOSAR Release Management	<ul style="list-style-type: none"> <li>• Requirements for NULL pointer check during Fls_Init removed</li> <li>• Minor formatting changes</li> </ul>

<b>Document Change History</b>			
<b>Date</b>	<b>Release</b>	<b>Changed by</b>	<b>Change Description</b>
2013-10-31	4.1.2	AUTOSAR Release Management	<ul style="list-style-type: none"> <li>• Timing requirement removed from module's main function</li> <li>• Fls_GetStatus returns MEMIF_UNINIT if module is not initialized</li> <li>• Editorial changes</li> <li>• Removed chapter(s) on change documentation</li> </ul>
2013-03-15	4.1.1	AUTOSAR Administration	<ul style="list-style-type: none"> <li>• Reworked according to the new SWS_BSWGeneral</li> <li>• Scope attribute in tables in chapter 10 added</li> <li>• Production errors changed to extended production errors</li> <li>• Requirement IDs for type definitions added</li> </ul>
2011-12-22	4.0.3	AUTOSAR Administration	<ul style="list-style-type: none"> <li>• References to HW specific errors corrected</li> <li>• Range of configuration parameters adapted</li> <li>• Consistency checking reformulated</li> <li>• Module short name changed</li> </ul>
2010-09-30	3.1.5	AUTOSAR Administration	<ul style="list-style-type: none"> <li>• Configuration parameter FlsDefaultMode added</li> <li>• Container with SPI reference added</li> <li>• Check for NULL pointer added</li> </ul>
2010-02-02	3.1.4	AUTOSAR Administration	<ul style="list-style-type: none"> <li>• References to AUTOSAR Standard Errors added</li> <li>• Range of configuration parameters restricted</li> <li>• Multiplicity of notification routines corrected</li> <li>• Several typing and formatting errors corrected</li> <li>• Legal disclaimer revised</li> </ul>
2008-08-13	3.1.1	AUTOSAR Administration	<ul style="list-style-type: none"> <li>• Legal disclaimer revised</li> </ul>
2008-02-01	3.0.2	AUTOSAR Administration	<ul style="list-style-type: none"> <li>• Table formatting corrected</li> </ul>

<b>Document Change History</b>			
<b>Date</b>	<b>Release</b>	<b>Changed by</b>	<b>Change Description</b>
2007-12-21	3.0.1	AUTOSAR Administration	<ul style="list-style-type: none"> <li>• NULL pointer check added to Fls_Compare</li> <li>• NULL pointer check detailed (in general)</li> <li>• Restriction removed to allow re-initialization of module</li> <li>• Tables in chapters 8 and 10 generated from UML model</li> <li>• Document meta information extended</li> <li>• Small layout adaptations made</li> </ul>
2007-01-24	2.1.15	AUTOSAR Administration	<ul style="list-style-type: none"> <li>• File include structure updated</li> <li>• Type usage corrected</li> <li>• Compare Job results adapted</li> <li>• API towards DEM corrected</li> <li>• Legal disclaimer revised</li> <li>• Release Notes added</li> <li>• “Advice for users” revised</li> <li>• “Revision Information” added</li> </ul>
2006-05-16	2.0	AUTOSAR Administration	<ul style="list-style-type: none"> <li>• Document structure adapted to common Release 2.0 SWS Template</li> <li>• new functionality: Read, Compare and SetMode functions</li> <li>• scalability: functionality can be configured (on/off)</li> <li>• adapted to new MemHwA architecture</li> </ul>
2005-05-31	1.0	AUTOSAR Administration	<ul style="list-style-type: none"> <li>• Initial release</li> </ul>

## Disclaimer

This work (specification and/or software implementation) and the material contained in it, as released by AUTOSAR, is for the purpose of information only. AUTOSAR and the companies that have contributed to it shall not be liable for any use of the work.

The material contained in this work is protected by copyright and other types of intellectual property rights. The commercial exploitation of the material contained in this work requires a license to such intellectual property rights.

This work may be utilized or reproduced without any modification, in any form or by any means, for informational purposes only. For any other purpose, no part of the work may be utilized or reproduced, in any form or by any means, without permission in writing from the publisher.

The work has been developed for automotive applications only. It has neither been developed, nor tested for non-automotive applications.

The word AUTOSAR and the AUTOSAR logo are registered trademarks.

## Table of Contents

1	Introduction and functional overview .....	7
2	Acronyms and abbreviations .....	8
3	Related documentation.....	9
3.1	AUTOSAR deliverables .....	9
3.2	Related specification .....	9
4	Constraints and assumptions .....	10
4.1	Limitations .....	10
4.2	Applicability to car domains .....	10
5	Dependencies to other modules.....	11
5.1	System clock .....	11
5.2	Communication or I/O drivers .....	11
6	Requirements traceability .....	12
7	Functional specification .....	22
7.1	General design rules .....	22
7.2	Error handling.....	23
7.2.1	Development errors .....	23
7.2.2	Runtime Errors.....	23
7.2.3	Transient Faults .....	24
7.2.4	Extended Production Errors and Production Errors .....	25
7.3	External flash driver.....	25
7.4	Loading, executing and removing the flash access code .....	25
8	API specification.....	27
8.1	Imported types.....	27
8.2	Type definitions .....	27
8.2.1	Fls_ConfigType.....	27
8.2.2	Fls_AddressType .....	27
8.2.3	Fls_LengthType .....	28
8.3	Function definitions.....	28
8.3.1	Fls_Init .....	28
8.3.2	Fls_Erase.....	30
8.3.3	Fls_Write.....	32
8.3.4	Fls_Cancel.....	34
8.3.5	Fls_GetStatus .....	35
8.3.6	Fls_GetJobResult .....	36
8.3.7	Fls_Read .....	37
8.3.8	Fls_Compare .....	39
8.3.9	Fls_SetMode.....	41
8.3.10	Fls_GetVersionInfo .....	42
8.3.11	Fls_BlankCheck.....	42
8.4	Call-back notifications.....	44
8.5	Scheduled functions .....	45

8.5.1	Fls_MainFunction.....	45
8.6	Expected Interfaces.....	49
8.6.1	Mandatory Interfaces .....	49
8.6.2	Optional Interfaces.....	49
8.6.3	Configurable interfaces .....	49
9	Sequence diagrams .....	52
9.1	Initialization.....	52
9.2	Synchronous functions .....	52
9.3	Asynchronous functions .....	53
9.4	Canceling a running job.....	54
10	Configuration specification.....	55
10.1	Containers and configuration parameters .....	55
10.1.1	Fls.....	55
10.1.2	FlsGeneral .....	57
10.1.3	FlsConfigSet.....	62
10.1.4	FlsExternalDriver .....	66
10.1.5	FlsSectorList.....	67
10.1.6	FlsSector .....	67
10.2	Published Information.....	70
10.2.1	FlsPublishedInformation .....	70
11	Not applicable requirements .....	74

## 1 Introduction and functional overview

This document specifies the functionality, API and the configuration of the AUTOSAR Basic Software module Flash Driver.

This specification is applicable to drivers for both internal and external flash memory.

The flash driver provides services for reading, writing and erasing flash memory and a configuration interface for setting / resetting the write / erase protection if supported by the underlying hardware.

In application mode of the ECU, the flash driver is only to be used by the Flash EEPROM emulation module for writing data. It is not intended to write program code to flash memory in application mode. This shall be done in boot mode which is out of scope of AUTOSAR.

A driver for an internal flash memory accesses the microcontroller hardware directly and is located in the Microcontroller Abstraction Layer. An external flash memory is usually connected via the microcontroller's data / address busses (memory mapped access), the flash driver then uses the handlers / drivers for those busses to access the external flash memory device. The driver for an external flash memory device is located in the ECU Abstraction Layer.

**[SWS\_FIs\_00088]** [The functional requirements and the functional scope are the same for both internal and external drivers. Hence the API is semantically identical.] (SRS\_FIs\_12147, SRS\_FIs\_12148)

## 2 Acronyms and abbreviations

<b>Abbreviation / Acronym:</b>	<b>Description:</b>
DET	Default Error Tracer – module to which development errors are reported.
DEM	Diagnostic Event Manager – module to which production relevant errors are reported.
Fls, FLS	Official AUTOSAR abbreviation for the module flash driver (different writing depending on the context, same meaning).
AC	(Flash) access code – abbreviation introduced to keep the names of the configuration parameters reasonably short.

Further definitions of terms used throughout this document

<b>Term:</b>	<b>Definition</b>
Flash sector	A flash sector is the smallest amount of flash memory that can be erased in one pass. The size of the flash sector depends upon the flash technology and is therefore hardware dependent.
Flash page	A flash page is the smallest amount of flash memory that can be programmed in one pass. The size of the flash page depends upon the flash technology and is therefore hardware dependent.
Flash access code	Internal flash driver routines called by the main function (job processing function) to erase or write the flash hardware.



## 3 Related documentation

### 3.1 AUTOSAR deliverables

- [1] List of Basic Software Modules  
AUTOSAR\_TR\_BSWModuleList.pdf
- [2] Layered Software Architecture,  
AUTOSAR\_EXP\_LayeredSoftwareArchitecture.pdf
- [3] General Requirements on Basic Software Modules,  
AUTOSAR\_SRS\_BSWGeneral.pdf
- [4] General Requirements on SPAL,  
AUTOSAR\_SRS\_SPALGeneral.pdf
- [5] Requirements on Flash Driver  
AUTOSAR\_SRS\_FlashDriver.pdf
- [6] Requirements on Memory Hardware Abstraction Layer  
AUTOSAR\_SRS\_MemoryHWAbstractionLayer.pdf
- [7] Specification of ECU Configuration  
AUTOSAR\_TPS\_ECUConfiguration.pdf
- [8] Basic Software Module Description Template  
AUTOSAR\_TPS\_BSWModuleDescriptionTemplate.pdf
- [9] General Specification of Basic Software Modules  
AUTOSAR\_SWS\_BSWGeneral.pdf

### 3.2 Related specification

AUTOSAR provides a General Specification on Basic Software modules [9] (SWS BSW General), which is also valid for Flash Driver.

Thus, the specification SWS BSW General shall be considered as additional and required specification for Flash Driver.

## 4 Constraints and assumptions

### 4.1 Limitations

- The flash driver only erases or programs complete flash sectors respectively flash pages, i.e. it does not offer any kind of re-write strategy since it does not use any internal buffers.
- The flash driver does not provide mechanisms for providing data integrity (e.g. checksums, redundant storage, etc.).

### 4.2 Applicability to car domains

No restrictions.

## 5 Dependencies to other modules

### 5.1 System clock

If the hardware of the internal flash memory depends on the system clock, changes to the system clock (e.g. PLL on → PLL off) may also affect the clock settings of the flash memory hardware.

### 5.2 Communication or I/O drivers

If the flash memory is located in an external device, the access to this device shall be enacted via the corresponding communication respectively I/O driver.

## 6 Requirements traceability

Requirement	Description	Satisfied by
RS_BRF_01064	AUTOSAR BSW shall provide callback functions in order to access upper layer modules	SWS_Fls_00109, SWS_Fls_00110, SWS_Fls_00147, SWS_Fls_00167, SWS_Fls_00262, SWS_Fls_00263, SWS_Fls_00273, SWS_Fls_00347, SWS_Fls_00348, SWS_Fls_00349
RS_BRF_01076	AUTOSAR basic software shall perform module local error recovery to the extent possible	SWS_Fls_00272, SWS_Fls_00359, SWS_Fls_00360, SWS_Fls_00361, SWS_Fls_00362, SWS_Fls_00371, SWS_Fls_00373
RS_BRF_01144	AUTOSAR shall support configuration parameters which allow to trade interrupt response time against runtime	SWS_Fls_00233, SWS_Fls_00234
SRS_BSW_00004	All Basic SW Modules shall perform a pre-processor check of the versions of all imported include files	SWS_Fls_00205, SWS_Fls_00206
SRS_BSW_00005	Modules of the $\mu$ C Abstraction Layer (MCAL) may not have hard coded horizontal interfaces	SWS_Fls_00366
SRS_BSW_00006	The source code of software modules above the $\mu$ C Abstraction Layer (MCAL) shall not be processor and compiler dependent.	SWS_Fls_00366
SRS_BSW_00007	All Basic SW Modules written in C language shall conform to the MISRA C 2012 Standard.	SWS_Fls_00366
SRS_BSW_00009	All Basic SW Modules shall be documented according to a common standard.	SWS_Fls_00366
SRS_BSW_00010	The memory consumption of all Basic SW Modules shall be documented for a defined configuration for all supported platforms.	SWS_Fls_00366
SRS_BSW_00101	The Basic Software Module shall be able to initialize variables and hardware in a separate initialization function	SWS_Fls_00014, SWS_Fls_00086, SWS_Fls_00191, SWS_Fls_00249
SRS_BSW_00160	Configuration files of AUTOSAR Basic SW module shall be readable for human beings	SWS_Fls_00366

SRS_BSW_00161	The AUTOSAR Basic Software shall provide a microcontroller abstraction layer which provides a standardized interface to higher software layers	SWS_Fls_00366
SRS_BSW_00162	The AUTOSAR Basic Software shall provide a hardware abstraction layer	SWS_Fls_00366
SRS_BSW_00164	The Implementation of interrupt service routines shall be done by the Operating System, complex drivers or modules	SWS_Fls_00193, SWS_Fls_00232
SRS_BSW_00167	All AUTOSAR Basic Software Modules shall provide configuration rules and constraints to enable plausibility checks	SWS_Fls_00205, SWS_Fls_00206
SRS_BSW_00168	SW components shall be tested by a function defined in a common API in the Basis-SW	SWS_Fls_00366
SRS_BSW_00170	The AUTOSAR SW Components shall provide information about their dependency from faults, signal qualities, driver demands	SWS_Fls_00366
SRS_BSW_00171	Optional functionality of a Basic-SW component that is not required in the ECU shall be configurable at pre-compile-time	SWS_Fls_00183, SWS_Fls_00184, SWS_Fls_00185, SWS_Fls_00186, SWS_Fls_00187
SRS_BSW_00172	The scheduling strategy that is built inside the Basic Software Modules shall be compatible with the strategy used in the system	SWS_Fls_00366
SRS_BSW_00300	All AUTOSAR Basic Software Modules shall be identified by an unambiguous name	SWS_Fls_00366
SRS_BSW_00302	All AUTOSAR Basic Software Modules shall only export information needed by other modules	SWS_Fls_00366
SRS_BSW_00304	All AUTOSAR Basic Software Modules shall use the following data types instead of native C data types	SWS_Fls_00366
SRS_BSW_00306	AUTOSAR Basic Software	SWS_Fls_00366

	Modules shall be compiler and platform independent	
SRS_BSW_00307	Global variables naming convention	SWS_Fls_00366
SRS_BSW_00308	AUTOSAR Basic Software Modules shall not define global data in their header files, but in the C file	SWS_Fls_00366
SRS_BSW_00309	All AUTOSAR Basic Software Modules shall indicate all global data with read-only purposes by explicitly assigning the const keyword	SWS_Fls_00366
SRS_BSW_00312	Shared code shall be reentrant	SWS_Fls_00366
SRS_BSW_00314	All internal driver modules shall separate the interrupt frame definition from the service routine	SWS_Fls_00366
SRS_BSW_00321	The version numbers of AUTOSAR Basic Software Modules shall be enumerated according specific rules	SWS_Fls_00366
SRS_BSW_00323	All AUTOSAR Basic Software Modules shall check passed API parameters for validity	SWS_Fls_00015, SWS_Fls_00020, SWS_Fls_00021, SWS_Fls_00026, SWS_Fls_00027, SWS_Fls_00097, SWS_Fls_00098, SWS_Fls_00157, SWS_Fls_00158, SWS_Fls_00205, SWS_Fls_00206, SWS_Fls_00363
SRS_BSW_00325	The runtime of interrupt service routines and functions that are running in interrupt context shall be kept short	SWS_Fls_00193
SRS_BSW_00327	Error values naming convention	SWS_Fls_00310, SWS_Fls_00312, SWS_Fls_00313, SWS_Fls_00314, SWS_Fls_00315, SWS_Fls_00316, SWS_Fls_00317, SWS_Fls_00318, SWS_Fls_00319
SRS_BSW_00328	All AUTOSAR Basic Software Modules shall avoid the duplication of code	SWS_Fls_00366
SRS_BSW_00330	It shall be allowed to use macros instead of functions where source code is used and runtime is critical	SWS_Fls_00366
SRS_BSW_00331	All Basic Software Modules shall strictly separate error and status information	SWS_Fls_00310, SWS_Fls_00312, SWS_Fls_00313, SWS_Fls_00314, SWS_Fls_00315, SWS_Fls_00316, SWS_Fls_00317, SWS_Fls_00318,

		SWS_Fls_00319
SRS_BSW_00333	For each callback function it shall be specified if it is called from interrupt context or not	SWS_Fls_00366
SRS_BSW_00334	All Basic Software Modules shall provide an XML file that contains the meta data	SWS_Fls_00366
SRS_BSW_00336	Basic SW module shall be able to shutdown	SWS_Fls_00366
SRS_BSW_00337	Classification of development errors	SWS_Fls_00310, SWS_Fls_00312, SWS_Fls_00313, SWS_Fls_00314, SWS_Fls_00315, SWS_Fls_00316, SWS_Fls_00317, SWS_Fls_00318, SWS_Fls_00319
SRS_BSW_00339	Reporting of production relevant error status	SWS_Fls_00104, SWS_Fls_00105, SWS_Fls_00106, SWS_Fls_00154, SWS_Fls_00260, SWS_Fls_00366
SRS_BSW_00341	Module documentation shall contains all needed informations	SWS_Fls_00366
SRS_BSW_00342	It shall be possible to create an AUTOSAR ECU out of modules provided as source code and modules provided as object code, even mixed	SWS_Fls_00366
SRS_BSW_00344	BSW Modules shall support link-time configuration	SWS_Fls_00366
SRS_BSW_00347	A Naming seperation of different instances of BSW drivers shall be in place	SWS_Fls_00366
SRS_BSW_00348	All AUTOSAR standard types and constants shall be placed and organized in a standard type header file	SWS_Fls_00366
SRS_BSW_00353	All integer type definitions of target and compiler specific scope shall be placed and organized in a single type header	SWS_Fls_00366
SRS_BSW_00359	All AUTOSAR Basic Software Modules callback functions shall avoid return types other than void if possible	SWS_Fls_00366
SRS_BSW_00360	AUTOSAR Basic Software Modules callback functions are allowed to have parameters	SWS_Fls_00366
SRS_BSW_00361	All mappings of not	SWS_Fls_00366

	standardized keywords of compiler specific scope shall be placed and organized in a compiler specific type and keyword header	
SRS_BSW_00371	The passing of function pointers as API parameter is forbidden for all AUTOSAR Basic Software Modules	SWS_Fls_00366
SRS_BSW_00375	Basic Software Modules shall report wake-up reasons	SWS_Fls_00366
SRS_BSW_00378	AUTOSAR shall provide a boolean type	SWS_Fls_00366
SRS_BSW_00385	List possible error notifications	SWS_Fls_00004, SWS_Fls_00104, SWS_Fls_00105, SWS_Fls_00106, SWS_Fls_00154, SWS_Fls_00310, SWS_Fls_00312, SWS_Fls_00313, SWS_Fls_00314, SWS_Fls_00315, SWS_Fls_00316, SWS_Fls_00317, SWS_Fls_00318, SWS_Fls_00319
SRS_BSW_00388	Containers shall be used to group configuration parameters that are defined for the same object	SWS_Fls_00352
SRS_BSW_00392	Parameters shall have a type	SWS_Fls_00248, SWS_Fls_00368, SWS_Fls_00369, SWS_Fls_00370
SRS_BSW_00398	The link-time configuration is achieved on object code basis in the stage after compiling and before linking	SWS_Fls_00366
SRS_BSW_00401	Documentation of multiple instances of configuration parameters shall be available	SWS_Fls_00366
SRS_BSW_00404	BSW Modules shall support post-build configuration	SWS_Fls_00014
SRS_BSW_00405	BSW Modules shall support multiple configuration sets	SWS_Fls_00014
SRS_BSW_00406	A static status variable denoting if a BSW module is initialized shall be initialized with value 0 before any APIs of the BSW module is called	SWS_Fls_00065, SWS_Fls_00066, SWS_Fls_00099, SWS_Fls_00240, SWS_Fls_00268, SWS_Fls_00356, SWS_Fls_00358, SWS_Fls_00382, SWS_Fls_00383
SRS_BSW_00407	Each BSW module shall provide a function to read out the version information	SWS_Fls_00259



	of a dedicated module implementation	
SRS_BSW_00415	Interfaces which are provided exclusively for one module shall be separated into a dedicated header file	SWS_Fls_00366
SRS_BSW_00416	The sequence of modules to be initialized shall be configurable	SWS_Fls_00366
SRS_BSW_00417	Software which is not part of the SW-C shall report error events only after the DEM is fully operational.	SWS_Fls_00366
SRS_BSW_00422	Pre-de-bouncing of error status information is done within the DEM	SWS_Fls_00366
SRS_BSW_00423	BSW modules with AUTOSAR interfaces shall be describable with the means of the SW-C Template	SWS_Fls_00366
SRS_BSW_00424	BSW module main processing functions shall not be allowed to enter a wait state	SWS_Fls_00366
SRS_BSW_00426	BSW Modules shall ensure data consistency of data which is shared between BSW modules	SWS_Fls_00366
SRS_BSW_00427	ISR functions shall be defined and documented in the BSW module description template	SWS_Fls_00366
SRS_BSW_00428	A BSW module shall state if its main processing function(s) has to be executed in a specific order or sequence	SWS_Fls_00366
SRS_BSW_00429	Access to OS is restricted	SWS_Fls_00366
SRS_BSW_00432	Modules should have separate main processing functions for read/receive and write/transmit data path	SWS_Fls_00269
SRS_BSW_00433	Main processing functions are only allowed to be called from task bodies provided by the BSW Scheduler	SWS_Fls_00366
SRS_BSW_00438	Configuration data shall be defined in a structure	SWS_Fls_00352, SWS_Fls_00355
		SWS_Fls_00353,

SRS_BSW_00466	Classification of extended production errors	SWS_Fls_00104, SWS_Fls_00106, SWS_Fls_00154	SWS_Fls_00105, SWS_Fls_00154
SRS_BSW_00469	Fault detection and healing of production errors and extended production errors	SWS_Fls_00260	
SRS_BSW_00483	BSW Modules shall handle buffer alignments internally	SWS_Fls_00389	
SRS_Fls_12107	The external flash driver shall check if the configured flash type matches with the hardware flash ID	SWS_Fls_00144	
SRS_Fls_12132	Flash driver shall be statically configurable	SWS_Fls_00048, SWS_Fls_00209, SWS_Fls_00217	SWS_Fls_00208, SWS_Fls_00216,
SRS_Fls_12134	The flash driver shall provide an asynchronous read function	SWS_Fls_00001, SWS_Fls_00097, SWS_Fls_00236, SWS_Fls_00239, SWS_Fls_00256, SWS_Fls_00338, SWS_Fls_00340	SWS_Fls_00035, SWS_Fls_00098, SWS_Fls_00238, SWS_Fls_00254, SWS_Fls_00337, SWS_Fls_00339,
SRS_Fls_12135	The flash driver shall provide an asynchronous write function	SWS_Fls_00001, SWS_Fls_00027, SWS_Fls_00146, SWS_Fls_00225, SWS_Fls_00251, SWS_Fls_00331, SWS_Fls_00333, SWS_Fls_00385	SWS_Fls_00026, SWS_Fls_00035, SWS_Fls_00223, SWS_Fls_00226, SWS_Fls_00254, SWS_Fls_00332, SWS_Fls_00334,
SRS_Fls_12136	The flash driver shall provide an asynchronous erase function	SWS_Fls_00001, SWS_Fls_00021, SWS_Fls_00145, SWS_Fls_00220, SWS_Fls_00250, SWS_Fls_00327, SWS_Fls_00329, SWS_Fls_00330	SWS_Fls_00020, SWS_Fls_00035, SWS_Fls_00218, SWS_Fls_00221, SWS_Fls_00254, SWS_Fls_00328,
SRS_Fls_12137	The flash driver shall provide a synchronous cancel function	SWS_Fls_00033, SWS_Fls_00183, SWS_Fls_00230, SWS_Fls_00254, SWS_Fls_00336	SWS_Fls_00035, SWS_Fls_00229, SWS_Fls_00252, SWS_Fls_00335,
SRS_Fls_12138	The flash driver shall provide a synchronous status function	SWS_Fls_00034, SWS_Fls_00253	SWS_Fls_00184,
SRS_Fls_12141	The flash driver shall verify written data	SWS_Fls_00056, SWS_Fls_00200	
SRS_Fls_12143	The flash driver shall handle only one job at one time	SWS_Fls_00002, SWS_Fls_00023, SWS_Fls_00033, SWS_Fls_00100, SWS_Fls_00323, SWS_Fls_00324	SWS_Fls_00003, SWS_Fls_00030, SWS_Fls_00036, SWS_Fls_00268,
SRS_Fls_12144	The flash driver shall	SWS_Fls_00037,	SWS_Fls_00038,

	provide a function that has to be called for job processing	SWS_Fls_00039, SWS_Fls_00220, SWS_Fls_00235, SWS_Fls_00243, SWS_Fls_00272, SWS_Fls_00346, SWS_Fls_00375, SWS_Fls_00377, SWS_Fls_00379	SWS_Fls_00196, SWS_Fls_00225, SWS_Fls_00238, SWS_Fls_00255, SWS_Fls_00345, SWS_Fls_00374, SWS_Fls_00376, SWS_Fls_00378,
SRS_Fls_12145	The job processing function of the flash driver shall process only as much data as the flash hardware can handle	SWS_Fls_00040	
SRS_Fls_12147	The same requirements shall apply for an external and internal flash driver	SWS_Fls_00088	
SRS_Fls_12148	The external flash driver shall have a semantically identical API as an internal flash driver	SWS_Fls_00088	
SRS_Fls_12149	The source code of the external flash driver shall be independent from the underlying microcontroller	SWS_Fls_00366	
SRS_Fls_12158	Before writing, the flash driver shall verify if the addressed memory area has been erased	SWS_Fls_00055	
SRS_Fls_12159	The write and erase functions of the Flash driver shall check the passed address parameters	SWS_Fls_00020, SWS_Fls_00026, SWS_Fls_00097, SWS_Fls_00380, SWS_Fls_00385	SWS_Fls_00021, SWS_Fls_00027, SWS_Fls_00098, SWS_Fls_00381,
SRS_Fls_12160	After execution of an erase job, the flash driver shall verify that the addressed block has been erased completely	SWS_Fls_00022	
SRS_Fls_12184	The flash driver shall limit the read access blocking times to the configured time	SWS_Fls_00040	
SRS_Fls_12193	The flash driver shall load the code that accesses the flash hardware to RAM whenever an erase or write job is started	SWS_Fls_00137, SWS_Fls_00141,	SWS_Fls_00140, SWS_Fls_00214
SRS_Fls_12194	The flash driver shall execute the code that accesses the flash hardware from RAM	SWS_Fls_00211, SWS_Fls_00213,	SWS_Fls_00212, SWS_Fls_00215
SRS_Fls_13300	The flash driver shall remove the code that	SWS_Fls_00143	

	accesses the flash hardware from RAM after the current job has been finished or canceled	
SRS_Fls_13301	The flash driver shall provide an asynchronous compare function	SWS_Fls_00001, SWS_Fls_00150, SWS_Fls_00151, SWS_Fls_00152, SWS_Fls_00153, SWS_Fls_00186, SWS_Fls_00241, SWS_Fls_00243, SWS_Fls_00244, SWS_Fls_00257, SWS_Fls_00341, SWS_Fls_00342, SWS_Fls_00343, SWS_Fls_00344
SRS_Fls_13302	The flash driver shall provide a synchronous selection function	SWS_Fls_00155, SWS_Fls_00156, SWS_Fls_00187, SWS_Fls_00258
SRS_Fls_13303	In normal mode, one cycle of the job processing function of the flash driver shall limit the block size to the default block size	SWS_Fls_00040
SRS_Fls_13304	In fast mode, one cycle of the job processing function of the flash driver shall limit the block size to the maximum block size	SWS_Fls_00040
SRS_MemHwAb_14005	The FEE and EA modules shall provide upper layers with a virtual 32bit address space	SWS_Fls_00209, SWS_Fls_00216, SWS_Fls_00217
SRS_SPAL_12057	All driver modules shall implement an interface for initialization	SWS_Fls_00014
SRS_SPAL_12063	All driver modules shall only support raw value mode	SWS_Fls_00366
SRS_SPAL_12064	All driver modules shall raise an error if the change of the operation mode leads to degradation of running operations	SWS_Fls_00366
SRS_SPAL_12067	All driver modules shall set their wake-up conditions depending on the selected operation mode	SWS_Fls_00366
SRS_SPAL_12069	All drivers of the SPAL that wake up from a wake-up interrupt shall report the wake-up reason	SWS_Fls_00366
SRS_SPAL_12078	The drivers shall be coded in a way that is most efficient in terms of memory and runtime resources	SWS_Fls_00366
SRS_SPAL_12163	All driver modules shall	SWS_Fls_00366

	implement an interface for de-initialization	
SRS_SPAL_12267	Wakeup sources shall be initialized by MCAL drivers and/or the MCU driver	SWS_Fls_00366
SRS_SPAL_12462	The register initialization settings shall be published	SWS_Fls_00366
SRS_SPAL_12463	The register initialization settings shall be combined and forwarded	SWS_Fls_00366

## 7 Functional specification

### 7.1 General design rules

**[SWS\_Fls\_00001]** [The FLS module shall offer asynchronous services for operations on flash memory (read/erase/write). ] (SRS\_Fls\_12134, SRS\_Fls\_12135, SRS\_Fls\_12136, SRS\_Fls\_13301)

**[SWS\_Fls\_00002]** [The FLS module shall not buffer data. The FLS module shall use application data buffers that are referenced by a pointer passed via the API. ] (SRS\_Fls\_12143)

**[SWS\_Fls\_00003]** [The FLS module shall not ensure data consistency of the given application buffer. ] (SRS\_Fls\_12143)

It is the responsibility of the FLS module's environment to ensure consistency of flash data during a flash read or write operation.

**[SWS\_Fls\_00205]** [The FLS module shall check static configuration parameters statically (at the latest during compile time) for correctness. ] (SRS\_BSW\_00323, SRS\_BSW\_00167, SRS\_BSW\_00004)

**[SWS\_Fls\_00206]** [The FLS module shall validate the version information in the FLS module header and source files for consistency (e.g. by comparing the version information in the module header and source files with a pre-processor macro). ] (SRS\_BSW\_00323, SRS\_BSW\_00167, SRS\_BSW\_00004)

**[SWS\_Fls\_00208]** [The FLS module shall combine all available flash memory areas into one linear address space (denoted by the parameters `FlsBaseAddress` and `FlsTotalSize`). ] (SRS\_Fls\_12132)

**[SWS\_Fls\_00209]** [The FLS module shall map the address and length parameters for the read, write, erase and compare functions as "virtual" addresses to the physical addresses according to the physical structure of the flash memory areas. ] (SRS\_Fls\_12132, SRS\_MemHwAb\_14005)

As long as the restrictions regarding the alignment of those addresses are met, it is allowed that a read, write or erase job crosses the boundaries of a physical flash memory area.

**[SWS\_Fls\_00389]** [ The FLS module shall handle data buffer alignment internally. Instead of imposing any requirements on RAM buffers' alignments (as they are uint8\*), it shall handle passed pointers as being just byte-aligned. ] (SRS\_BSW\_00483)

**[SWS\_Fls\_00390]** [ If more than one instance of the flash driver is used in an ECU, the individual instances have to be given a unique instance ID. This instance ID shall be configured as the parameter FlsDriverIndex. If only one instance of the flash driver is used in an ECU, this instance shall have the parameter FlsDriverIndex configured as 0. ]()

## 7.2 Error handling

The FLS module shall be able to detect the following errors and exceptions depending on its configuration:

### 7.2.1 Development errors

**[SWS\_Fls\_00004]** [

Type or error	Related error code	Value [hex]
API service called with wrong parameter	FLS_E_PARAM_CONFIG	0x01
	FLS_E_PARAM_ADDRESS	0x02
	FLS_E_PARAM_LENGTH	0x03
	FLS_E_PARAM_DATA	0x04
API service called without module initialization	FLS_E_UNINIT	0x05
API service called while driver still busy	FLS_E_BUSY	0x06
API service called with NULL pointer	FLS_E_PARAM_POINTER	0x0a

] (SRS\_BSW\_00385)

**[SWS\_Fls\_00310]** [The following development error codes shall be reported when an API service is called with a wrong parameter: FLS\_E\_PARAM\_CONFIG, FLS\_E\_PARAM\_ADDRESS, FLS\_E\_PARAM\_LENGTH, FLS\_E\_PARAM\_DATA. ] (SRS\_BSW\_00337, SRS\_BSW\_00385, SRS\_BSW\_00327, SRS\_BSW\_00331)

**[SWS\_Fls\_00312]** [The development error code FLS\_E\_BUSY shall be reported when an API service is called while the module is still busy. ] (SRS\_BSW\_00337, SRS\_BSW\_00385, SRS\_BSW\_00327, SRS\_BSW\_00331)

### 7.2.2 Runtime Errors

Type or error	Related error code	Value [hex]
Erase verification (blank check) failed	FLS_E_VERIFY_ERASE_FAILED	0x07

Write verification (compare) failed	FLS_E_VERIFY_WRITE_FAILED	0x08
Timeout exceeded	FLS_E_TIMEOUT	0x09

**[SWS\_Fls\_00313]** [The runtime error code `FLS_E_VERIFY_ERASE_FAILED` shall be reported when the erase verification function is enabled (by the compile switch `FlsEraseVerificationEnabled`) and the erase verification function (blankcheck) failed. ] (SRS\_BSW\_00337, SRS\_BSW\_00385, SRS\_BSW\_00327, SRS\_BSW\_00331)

**[SWS\_Fls\_00314]** [The runtime error code `FLS_E_VERIFY_WRITE_FAILED` shall be reported when the write verification function is enabled (by the compile switch `FlsWriteVerificationEnabled`) and the write verification function (compare) failed. ] (SRS\_BSW\_00337, SRS\_BSW\_00385, SRS\_BSW\_00327, SRS\_BSW\_00331)

**[SWS\_Fls\_00361]** [The runtime error code `FLS_E_TIMEOUT` shall be reported when the timeout supervision function is enabled (by the compile switch `FlsTimeoutSupervisionEnabled`) and the timeout supervision of a read, write, erase or compare job (in hardware) failed. ] (RS\_BRF\_01076)

### 7.2.3 Transient Faults

Type or error	Related error code	Value [hex]
Flash erase failed (HW)	FLS_E_ERASE_FAILED	0x01
Flash write failed (HW)	FLS_E_WRITE_FAILED	0x02
Flash read failed (HW)	FLS_E_READ_FAILED	0x03
Flash compare failed (HW)	FLS_E_COMPARE_FAILED	0x04
Expected hardware ID not matched (see <a href="#">SWS_Fls_00144</a> )	FLS_E_UNEXPECTED_FLASH_ID	0x05

**[SWS\_Fls\_00315]** [The transient fault code `FLS_E_ERASE_FAILED` shall be reported when the flash erase function failed (in hardware). ] (SRS\_BSW\_00337, SRS\_BSW\_00385, SRS\_BSW\_00327, SRS\_BSW\_00331)

**[SWS\_Fls\_00316]** [The transient fault code `FLS_E_WRITE_FAILED` shall be reported when the flash write function failed (in hardware). ] (SRS\_BSW\_00337, SRS\_BSW\_00385, SRS\_BSW\_00327, SRS\_BSW\_00331)

**[SWS\_Fls\_00317]** [The transient fault code `FLS_E_READ_FAILED` shall be reported when the flash read function failed (in hardware). ] (SRS\_BSW\_00337, SRS\_BSW\_00385, SRS\_BSW\_00327, SRS\_BSW\_00331)

**[SWS\_Fls\_00318]** [The transient fault code `FLS_E_COMPARE_FAILED` shall be reported when the flash compare function failed (in hardware). ] (SRS\_BSW\_00337, SRS\_BSW\_00385, SRS\_BSW\_00327, SRS\_BSW\_00331)



**[SWS\_Fls\_00319]** [The transient fault code `FLS_E_UNEXPECTED_FLASH_ID` shall be reported when the expected flash ID is not matched (see [SWS\\_Fls\\_00144](#)). ] (SRS\_BSW\_00337, SRS\_BSW\_00385, SRS\_BSW\_00327, SRS\_BSW\_00331)

## 7.2.4 Extended Production Errors and Production Errors

This module does not specify any production errors.

## 7.3 External flash driver

**[SWS\_Fls\_00144]** [During the initialization of the external flash driver, the FLS module shall check the hardware ID of the external flash device against the corresponding published parameter. If a hardware ID mismatch occurs, the FLS module shall report the error code `FLS_E_UNEXPECTED_FLASH_ID` to the Default Error Tracer (DET), set the FLS module status to `FLS_E_UNINIT` and shall not initialize itself. ] (SRS\_Fls\_12107)

A complete list of required parameters is specified in the SPI Handler/Driver Software Specification (Chapter “Configuration Specification”, marked as “SPI User”).

## 7.4 Loading, executing and removing the flash access code

Technical background information: Flash technology or flash memory segmentation may require that the routines that access the flash hardware (internal erase and write routines) are executed from RAM because reading the flash – for instruction fetch needed for code execution – is not allowed while programming the flash.

**[SWS\_Fls\_00137]** [The FLS module’s implementer shall place the code of the flash access routines into a separate C-module `Fls_ac.c`. ] (SRS\_Fls\_12193)

**[SWS\_Fls\_00215]** [The FLS module’s flash access routines shall only disable interrupts and wait for the completion of the erase / write command if necessary (that is if it has to be ensured that no other code is executed in the meantime). ] (SRS\_Fls\_12194)

**[SWS\_Fls\_00211]** [The FLS module’s implementer shall keep the execution time for the flash access code as short as possible. ] (SRS\_Fls\_12194)

**[SWS\_Fls\_00140]** [The FLS module’s erase routine shall load the flash access code for erasing the flash memory to the location in RAM pointed to by the erase function pointer contained in the flash drivers configuration set if the FLS module is configured to load the flash access code to RAM on job start. ] (SRS\_Fls\_12193)

**[SWS\_Fls\_00141]** [The FLS module's write routine shall load the flash access code for writing the flash memory to the location in RAM pointed to by the write function pointer contained in the flash drivers configuration set if the FLS module is configured to load the flash access code to RAM on job start. ] (SRS\_Fls\_12193)

**[SWS\_Fls\_00212]** [The FLS module's main processing routine shall execute the flash access code routines. ] (SRS\_Fls\_12194)

**[SWS\_Fls\_00213]** [The FLS module's main processing routine shall access the flash access code routines by means of the respective function pointer contained in the FLS module's configuration set (post-compile parameters) regardless whether the flash access code routines have been loaded to RAM or whether they can be executed directly from (flash) ROM. ] (SRS\_Fls\_12194)

**[SWS\_Fls\_00143]** [After an erase or write job has been finished or canceled, the FLS module's main processing routine shall unload (i.e. overwrite) the flash access code (internal erase / write routines) from RAM if they have been loaded to RAM by the flash driver. ] (SRS\_Fls\_13300)

**[SWS\_Fls\_00214]** [The FLS module shall only load the access code to the RAM if the access code cannot be executed out of flash ROM. ] (SRS\_Fls\_12193)

## 8 API specification

### 8.1 Imported types

[SWS\_Fls\_00248]

<i>Module</i>	<i>Header File</i>	<i>Imported Type</i>
Memlf	Memlf.h	Memlf_JobResultType
	Memlf.h	Memlf_ModeType
	Memlf.h	Memlf_StatusType
Std	Std_Types.h	Std_ReturnType
	Std_Types.h	Std_VersionInfoType

](SRS\_BSW\_00392)

### 8.2 Type definitions

#### 8.2.1 Fls\_ConfigType

[SWS\_Fls\_00368]

<b>Name</b>	Fls_ConfigType	
<b>Kind</b>	Structure	
<b>Elements</b>	Hardware dependend structure	
	<b>Type</b>	--
	<b>Comment</b>	Structure to hold the flash driver configuration set. The contents of the initialisation data structure are specific to the flash memory hardware.
<b>Description</b>	A pointer to such a structure is provided to the flash driver initialization routine for configuration of the driver and flash memory hardware.	
<b>Available via</b>	Fls.h	

](SRS\_BSW\_00392)

#### 8.2.2 Fls\_AddressType

[SWS\_Fls\_00369]

<b>Name</b>	Fls_AddressType
-------------	-----------------

<b>Kind</b>	Type		
<b>Derived from</b>	uint		
<b>Range</b>	8 / 16 / 32 bits	--	Size depends on target platform and flash device.
<b>Description</b>	Used as address offset from the configured flash base address to access a certain flash memory area.		
<b>Available via</b>	Fls.h		

](SRS\_BSW\_00392)

**[SWS\_Fls\_00216]** [The type Fls\_AddressType shall have 0 as lower limit for each flash device. ] (SRS\_Fls\_12132, SRS\_MemHwAb\_14005)

**[SWS\_Fls\_00217]** [The FLS module shall add a device specific base address to the address type Fls\_AddressType if necessary. ] (SRS\_Fls\_12132, SRS\_MemHwAb\_14005)

### 8.2.3 Fls\_LengthType

**[SWS\_Fls\_00370]**[

<b>Name</b>	Fls_LengthType		
<b>Kind</b>	Type		
<b>Derived from</b>	uint		
<b>Range</b>	Same as Fls_AddressType	--	Shall be the same type as Fls_AddressType because of arithmetic operations. Size depends on target platform and flash device.
<b>Description</b>	Specifies the number of bytes to read/write/erase/compare.		
<b>Available via</b>	Fls.h		

](SRS\_BSW\_00392)

## 8.3 Function definitions

### 8.3.1 Fls\_Init

**[SWS\_Fls\_00249]**[

<b>Service Name</b>	Fls_Init	
<b>Syntax</b>	<pre>void Fls_Init (     const Fls_ConfigType* ConfigPtr )</pre>	
<b>Service ID [hex]</b>	0x00	
<b>Sync/Async</b>	Synchronous	
<b>Reentrancy</b>	Non Reentrant	
<b>Parameters (in)</b>	ConfigPtr	Pointer to flash driver configuration set.
<b>Parameters (inout)</b>	None	
<b>Parameters (out)</b>	None	
<b>Return value</b>	None	
<b>Description</b>	Initializes the Flash Driver.	
<b>Available via</b>	Fls.h	

](SRS\_BSW\_00101)

**[SWS\_Fls\_00014]** [The function `Fls_Init` shall initialize the FLS module (software) and all flash memory relevant registers (hardware) with parameters provided in the given configuration set. ] (SRS\_BSW\_00404, SRS\_BSW\_00405, SRS\_BSW\_00101, SRS\_SPAL\_12057)

**[SWS\_Fls\_00191]** [The function `Fls_Init` shall store the pointer to the given configuration set in a variable in order to allow the FLS module access to the configuration set contents during runtime. ] (SRS\_BSW\_00101)

**[SWS\_Fls\_00086]** [The function `Fls_Init` shall initialize all FLS module global variables and those controller registers that are needed for controlling the flash device and that do not influence or depend on other (hardware) modules. Registers that can influence or depend on other modules shall be initialized by a common system module. ] (SRS\_BSW\_00101)

**[SWS\_Fls\_00015]** [If development error detection for the module FLS is enabled: the function `Fls_Init` shall check the (hardware specific) contents of the given configuration set for being within the allowed range. If this is not the case, it shall raise the development error `FLS_E_PARAM_CONFIG`. ] (SRS\_BSW\_00323)

**[SWS\_Fls\_00323]** [The function `Fls_Init` shall set the FLS module state to `MEMIF_IDLE` after having finished the FLS module initialization. ] (SRS\_Fls\_12143)

**[SWS\_Fls\_00324]** [The function `Fls_Init` shall set the flash job result to `MEMIF_JOB_OK` after having finished the FLS module initialization. ] (SRS\_Fls\_12143)

**[SWS\_Fls\_00268]** [If development error detection for the module Fls is enabled: the function `Fls_Init` shall check that the FLS module is currently not busy (FLS module state is not `MEMIF_BUSY`). If this check fails, the function `Fls_Init` shall raise the development error `FLS_E_BUSY`. ] (SRS\_Fls\_12143, SRS\_BSW\_00406)

**[SWS\_Fls\_00048]** [If supported by hardware, the function `Fls_Init` shall set the flash memory erase/write protection as provided in the configuration set. ] (SRS\_Fls\_12132)

### 8.3.2 Fls\_Erase

**[SWS\_Fls\_00250]**

<b>Service Name</b>	Fls_Erase	
<b>Syntax</b>	<pre>Std_ReturnType Fls_Erase (     Fls_AddressType TargetAddress,     Fls_LengthType Length )</pre>	
<b>Service ID [hex]</b>	0x01	
<b>Sync/Async</b>	Asynchronous	
<b>Reentrancy</b>	Non Reentrant	
<b>Parameters (in)</b>	Target Address	Target address in flash memory. This address offset will be added to the flash memory base address. Min.: 0 Max.: <code>FLS_SIZE - 1</code>
	Length	Number of bytes to erase Min.: 1 Max.: <code>FLS_SIZE - TargetAddress</code>
<b>Parameters (inout)</b>	None	
<b>Parameters (out)</b>	None	
<b>Return value</b>	Std_Return-Type	E_OK: erase command has been accepted E_NOT_OK: erase command has not been accepted
<b>Description</b>	Erases flash sector(s).	
<b>Available via</b>	Fls.h	

](SRS\_Fls\_12136)

**[SWS\_Fls\_00218]** [The job of the function `Fls_Erase` shall erase one or more complete flash sectors. ] (SRS\_Fls\_12136)

**[SWS\_Fls\_00327]** [The function `Fls_Erase` shall copy the given parameters to FLS module internal variables and initiate an erase job. ] (SRS\_Fls\_12136)

**[SWS\_Fls\_00328]** [After initiating the erase job, the function `Fls_Erase` shall set the FLS module status to `MEMIF_BUSY`. ] (SRS\_Fls\_12136)

**[SWS\_Fls\_00329]** [After initiating the erase job, the function `Fls_Erase` shall set the job result to `MEMIF_JOB_PENDING`. ] (SRS\_Fls\_12136)

**[SWS\_Fls\_00330]** [After initiating the erase job, the function `Fls_Erase` shall return with `E_OK`. ] (SRS\_Fls\_12136)

**[SWS\_Fls\_00220]** [The FLS module shall execute the job of the function `Fls_Erase` asynchronously within the FLS module's main function. ] (SRS\_Fls\_12136, SRS\_Fls\_12144)

**[SWS\_Fls\_00221]** [The job of the function `Fls_Erase` shall erase a flash memory block starting from `FlsBaseAddress + TargetAddress` of size `Length`. ]

Note: `Length` will be rounded up to the next full sector boundary since only complete flash sectors can be erased. ] (SRS\_Fls\_12136)

**[SWS\_Fls\_00020]** [If development error detection for the module FLS is enabled: the function `Fls_Erase` shall check that the erase start address (`FlsBaseAddress + TargetAddress`) is aligned to a flash sector boundary and that it lies within the specified lower and upper flash address boundaries. If this check fails, the function `Fls_Erase` shall reject the erase request, raise the development error `FLS_E_PARAM_ADDRESS` and return with `E_NOT_OK`. ] (SRS\_BSW\_00323, SRS\_Fls\_12136, SRS\_Fls\_12159)

**[SWS\_Fls\_00021]** [If development error detection for the module FLS is enabled: the function `Fls_Erase` shall check that the erase length is greater than 0 and that the erase end address (erase start address + length) is aligned to a flash sector boundary and that it lies within the specified upper flash address boundary. If this check fails, the function `Fls_Erase` shall reject the erase request, raise the development error `FLS_E_PARAM_LENGTH` and return with `E_NOT_OK`. ] (SRS\_BSW\_00323, SRS\_Fls\_12136, SRS\_Fls\_12159)

**[SWS\_Fls\_00065]** [If development error detection for the module FLS is enabled: the function `Fls_Erase` shall check that the FLS module has been initialized. If this check fails, the function `Fls_Erase` shall reject the erase request, raise the development error `FLS_E_UNINIT` and return with `E_NOT_OK`. ] (SRS\_BSW\_00406)

**[SWS\_Fls\_00023]** [If development error detection for the module FLS is enabled: the function `Fls_Erase` shall check that the FLS module is currently not busy. If this

check fails, the function `Fls_Erase` shall reject the erase request, raise the development error `FLS_E_BUSY` and return with `E_NOT_OK`. ] (SRS\_Fls\_12143)

**[SWS\_Fls\_00145]** [If possible, e.g. with interrupt controlled implementations, the FLS module shall start the first round of the erase job directly within the function `Fls_Erase` to reduce overall runtime. ] (SRS\_Fls\_12136)

### 8.3.3 Fls\_Write

**[SWS\_Fls\_00251]**

<b>Service Name</b>	Fls_Write	
<b>Syntax</b>	<pre>Std_ReturnType Fls_Write (     Fls_AddressType TargetAddress,     const uint8* SourceAddressPtr,     Fls_LengthType Length )</pre>	
<b>Service ID [hex]</b>	0x02	
<b>Sync/Async</b>	Asynchronous	
<b>Reentrancy</b>	Non Reentrant	
<b>Parameters (in)</b>	Target Address	Target address in flash memory. This address offset will be added to the flash memory base address. Min.: 0 Max.: FLS_SIZE - 1
	Source AddressPtr	Pointer to source data buffer
	Length	Number of bytes to write Min.: 1 Max.: FLS_SIZE - TargetAddress
<b>Parameters (inout)</b>	None	
<b>Parameters (out)</b>	None	
<b>Return value</b>	Std_Return-Type	E_OK: write command has been accepted E_NOT_OK: write command has not been accepted
<b>Description</b>	Writes one or more complete flash pages.	
<b>Available via</b>	Fls.h	

](SRS\_Fls\_12135)

**[SWS\_Fls\_00223]** [The job of the function `Fls_Write` shall write one or more complete flash pages to the flash device. ] (SRS\_Fls\_12135)

**[SWS\_Fls\_00331]** [The function `Fls_Write` shall copy the given parameters to Fls module internal variables and initiate a write job. ] (SRS\_Fls\_12135)



**[SWS\_Fls\_00332]** [After initiating the write job, the function `Fls_Write` shall set the FLS module status to `MEMIF_BUSY`. ] (SRS\_Fls\_12135)

**[SWS\_Fls\_00333]** [After initiating the write job, the function `Fls_Write` shall set the job result to `MEMIF_JOB_PENDING`. ] (SRS\_Fls\_12135)

**[SWS\_Fls\_00334]** [After initiating the write job, the function `Fls_Write` shall return with `E_OK`. ] (SRS\_Fls\_12135)

**[SWS\_Fls\_00225]** [The FLS module shall execute the write job of the function `Fls_Write` asynchronously within the FLS module's main function. ] (SRS\_Fls\_12135, SRS\_Fls\_12144)

**[SWS\_Fls\_00226]** [The job of the function `Fls_Write` shall program a flash memory block with data provided via `SourceAddressPtr` starting from `FlsBaseAddress + TargetAddress` of size `Length`. ] (SRS\_Fls\_12135)

**[SWS\_Fls\_00026]** [If development error detection for the module FLS is enabled: the function `Fls_Write` shall check that the write start address (`FlsBaseAddress + TargetAddress`) is aligned to a flash page boundary and that it lies within the specified lower and upper flash address boundaries. If this check fails, the function `Fls_Write` shall reject the write request, raise the development error `FLS_E_PARAM_ADDRESS` and return with `E_NOT_OK`. ] (SRS\_BSW\_00323, SRS\_Fls\_12135, SRS\_Fls\_12159)

**[SWS\_Fls\_00027]** [If development error detection for the module FLS is enabled: the function `Fls_Write` shall check that the write length is greater than 0, that the write end address (write start address + length) is aligned to a flash page boundary and that it lies within the specified upper flash address boundary. If this check fails, the function `Fls_Write` shall reject the write request, raise the development error `FLS_E_PARAM_LENGTH` and return with `E_NOT_OK`. ] (SRS\_BSW\_00323, SRS\_Fls\_12135, SRS\_Fls\_12159)

**[SWS\_Fls\_00066]** [If development error detection for the module FLS is enabled: the function `Fls_Write` shall check that the FLS module has been initialized. If this check fails, the function `Fls_Write` shall reject the write request, raise the development error `FLS_E_UNINIT` and return with `E_NOT_OK`. ] (SRS\_BSW\_00406)

**[SWS\_Fls\_00030]** [If development error detection for the module FLS is enabled: the function `Fls_Write` shall check that the FLS module is currently not busy. If this check fails, the function `Fls_Write` shall reject the write request, raise the development error `FLS_E_BUSY` and return with `E_NOT_OK`. ] (SRS\_Fls\_12143)

**[SWS\_Fls\_00157]** [If development error detection for the module FLS is enabled: the function `Fls_Write` shall check the given data buffer pointer for not being a null

pointer. If the data buffer pointer is a null pointer, the function `Fls_Write` shall reject the write request, raise the development error `FLS_E_PARAM_DATA` and return with `E_NOT_OK`. ] (SRS\_BSW\_00323)

**[SWS\_Fls\_00146]** [If possible, e.g. with interrupt controlled implementations, the FLS module shall start the first round of the write job directly within the function `Fls_Write` to reduce overall runtime. ] (SRS\_Fls\_12135)

### 8.3.4 Fls\_Cancel

**[SWS\_Fls\_00252]**[

<b>Service Name</b>	Fls_Cancel
<b>Syntax</b>	<pre>void Fls_Cancel (     void )</pre>
<b>Service ID [hex]</b>	0x03
<b>Sync/Async</b>	Synchronous
<b>Reentrancy</b>	Non Reentrant
<b>Parameters (in)</b>	None
<b>Parameters (inout)</b>	None
<b>Parameters (out)</b>	None
<b>Return value</b>	None
<b>Description</b>	Cancels an ongoing job.
<b>Available via</b>	Fls.h

](SRS\_Fls\_12137)

**[SWS\_Fls\_00229]** [The function `Fls_Cancel` shall cancel an ongoing flash read, write, erase or compare job. ] (SRS\_Fls\_12137)

**[SWS\_Fls\_00230]** [The function `Fls_Cancel` shall abort a running job synchronously so that directly after returning from this function a new job can be started. ] (SRS\_Fls\_12137)

Note: The function `Fls_Cancel` is synchronous in its behaviour but at the same time asynchronous w.r.t. the underlying hardware: The job of the `Fls_Cancel` function (i.e. make the module ready for a new job request) is finished when it returns to the caller (hence it's synchronous) but on the other hand e.g. an erase job might still be ongoing in the hardware device (hence it's asynchronous w.r.t. the hardware).

**[SWS\_Fls\_00335]** [The function `Fls_Cancel` shall reset the FLS module's internal job processing variables (like address, length and data pointer). ] (SRS\_Fls\_12137)

**[SWS\_Fls\_00336]** [The function `Fls_Cancel` shall set the FLS module state to `MEMIF_IDLE`. ] (SRS\_Fls\_12137)

**[SWS\_Fls\_00033]** [The function `Fls_Cancel` shall set the job result to `MEMIF_JOB_CANCELED` if the job result currently has the value `MEMIF_JOB_PENDING`. Otherwise the function `Fls_Cancel` shall leave the job result unchanged. ] (SRS\_Fls\_12137, SRS\_Fls\_12143)

**[SWS\_Fls\_00147]** [If configured, the function `Fls_Cancel` shall call the error notification function to inform the caller about the cancellation of a job. ] (RS\_BRF\_01064)

*Note: The content of the affected flash memory cells will be undefined when canceling an ongoing job with the function `Fls_Cancel`.*

**[SWS\_Fls\_00183]** [The function `Fls_Cancel` shall be pre-compile time configurable On/Off by the configuration parameter `FlsCancelApi`. ] (SRS\_BSW\_00171, SRS\_Fls\_12137)

**[SWS\_Fls\_00356]** [If development error detection for the module FLS is enabled: the function `Fls_Cancel` shall check that the FLS module has been initialized. If this check fails, the function `Fls_Cancel` shall raise the development error `FLS_E_UNINIT` and return. ] (SRS\_BSW\_00406)

### 8.3.5 Fls\_GetStatus

**[SWS\_Fls\_00253]**

<b>Service Name</b>	Fls_GetStatus
<b>Syntax</b>	<pre>MemIf_StatusType Fls_GetStatus (     void )</pre>
<b>Service ID [hex]</b>	0x04
<b>Sync/Async</b>	Synchronous
<b>Reentrancy</b>	Reentrant
<b>Parameters (in)</b>	None
<b>Parameters (inout)</b>	None
<b>Parameters (out)</b>	None

<b>Return value</b>	MemIf_StatusType	--
<b>Description</b>	Returns the driver state.	
<b>Available via</b>	Fls.h	

](SRS\_Fls\_12138)

**[SWS\_Fls\_00034]** [The function `Fls_GetStatus` shall return the FLS module state synchronously. ] (SRS\_Fls\_12138)

**[SWS\_Fls\_00184]** [The function `Fls_GetStatus` shall be pre-compile time configurable On/Off by the configuration parameter `FlsGetStatusApi`. ] (SRS\_Fls\_12138, SRS\_BSW\_00171)

Note: The function `Fls_GetStatus` may be called before the module has been initialized in which case it shall return `MEMIF_UNINIT`.

### 8.3.6 Fls\_GetJobResult

**[SWS\_Fls\_00254]**[

<b>Service Name</b>	Fls_GetJobResult	
<b>Syntax</b>	<pre>MemIf_JobResultType Fls_GetJobResult (     void )</pre>	
<b>Service ID [hex]</b>	0x05	
<b>Sync/Async</b>	Synchronous	
<b>Reentrancy</b>	Reentrant	
<b>Parameters (in)</b>	None	
<b>Parameters (inout)</b>	None	
<b>Parameters (out)</b>	None	
<b>Return value</b>	MemIf_JobResultType	--
<b>Description</b>	Returns the result of the last job.	
<b>Available via</b>	Fls.h	

](SRS\_Fls\_12134, SRS\_Fls\_12135, SRS\_Fls\_12136, SRS\_Fls\_12137)

**[SWS\_Fls\_00035]** [The function `Fls_GetJobResult` shall return the result of the last job synchronously] (SRS\_Fls\_12134, SRS\_Fls\_12135, SRS\_Fls\_12136, SRS\_Fls\_12137)

**[SWS\_Fls\_00036]** [The erase, write, read and compare functions shall share the same job result, i.e. only the result of the last job can be queried. The FLS module shall overwrite the job result with MEMIF\_JOB\_PENDING if the FLS module has accepted a new job. ] (SRS\_Fls\_12143)

**[SWS\_Fls\_00185]** [The function `Fls_GetJobResult` shall be pre-compile time configurable On/Off by the configuration parameter `FlsGetJobResultApi`. ] (SRS\_BSW\_00171)

**[SWS\_Fls\_00358]** [If development error detection for the module FLS is enabled: the function `Fls_GetJobResult` shall check that the FLS module has been initialized. If this check fails, the function `Fls_GetJobResult` shall raise the development error `FLS_E_UNINIT` and return with `MEMIF_JOB_FAILED`. ] (SRS\_BSW\_00406)

### 8.3.7 Fls\_Read

**[SWS\_Fls\_00256]**

<b>Service Name</b>	Fls_Read	
<b>Syntax</b>	<pre>Std_ReturnType Fls_Read (     Fls_AddressType SourceAddress,     uint8* TargetAddressPtr,     Fls_LengthType Length )</pre>	
<b>Service ID [hex]</b>	0x07	
<b>Sync/Async</b>	Asynchronous	
<b>Reentrancy</b>	Non Reentrant	
<b>Parameters (in)</b>	Source Address	Source address in flash memory. This address offset will be added to the flash memory base address. Min.: 0 Max.: FLS_SIZE - 1
	Length	Number of bytes to read Min.: 1 Max.: FLS_SIZE - SourceAddress
<b>Parameters (inout)</b>	None	
<b>Parameters (out)</b>	Target AddressPtr	Pointer to target data buffer
<b>Return value</b>	Std_Return-Type	E_OK: read command has been accepted E_NOT_OK: read command has not been accepted
<b>Description</b>	Reads from flash memory.	
<b>Available via</b>	Fls.h	

](SRS\_Fls\_12134)

**[SWS\_Fls\_00236]** [The function `Fls_Read` shall read from flash memory. ]  
(SRS\_Fls\_12134)

**[SWS\_Fls\_00337]** [The function `Fls_Read` shall copy the given parameters to FLS module internal variables and initiate a read job. ] (SRS\_Fls\_12134)

**[SWS\_Fls\_00338]** [After initiating a read job, the function `Fls_Read` shall set the FLS module status to `MEMIF_BUSY`. ] (SRS\_Fls\_12134)

**[SWS\_Fls\_00339]** [After initiating a read job, the function `Fls_Read` shall set the FLS module job result to `MEMIF_JOB_PENDING`. ] (SRS\_Fls\_12134)

**[SWS\_Fls\_00340]** [After initiating a read job, the function `Fls_Read` shall return with `E_OK`. ] (SRS\_Fls\_12134)

**[SWS\_Fls\_00238]** [The FLS module shall execute the read job of the function `Fls_Read` asynchronously within the FLS module's main function. ] (SRS\_Fls\_12134, SRS\_Fls\_12144)

**[SWS\_Fls\_00239]** [The read job of the function `Fls_Read` shall copy a continuous flash memory block starting from `FlsBaseAddress + SourceAddress` of size `Length` to the buffer pointed to by `TargetAddressPtr`. ] (SRS\_Fls\_12134)

**[SWS\_Fls\_00097]** [If development error detection for the module FLS is enabled: the function `Fls_Read` shall check that the read start address (`FlsBaseAddress + SourceAddress`) lies within the specified lower and upper flash address boundaries. If this check fails, the function `Fls_Read` shall reject the read job, raise development error `FLS_E_PARAM_ADDRESS` and return with `E_NOT_OK`. ] (SRS\_BSW\_00323, SRS\_Fls\_12134, SRS\_Fls\_12159)

**[SWS\_Fls\_00098]** [If development error detection for the module FLS is enabled: the function `Fls_Read` shall check that the read length is greater than 0 and that the read end address (read start address + length) lies within the specified upper flash address boundary. If this check fails, the function `Fls_Read` shall reject the read job, raise the development error `FLS_E_PARAM_LENGTH` and return with `E_NOT_OK`. ] (SRS\_BSW\_00323, SRS\_Fls\_12134, SRS\_Fls\_12159)

**[SWS\_Fls\_00099]** [If development error detection for the module FLS is enabled: the function `Fls_Read` shall check that the driver has been initialized. If this check fails, the function `Fls_Read` shall reject the read request, raise the development error `FLS_E_UNINIT` and return with `E_NOT_OK`. ] (SRS\_BSW\_00406)

**[SWS\_Fls\_00100]** [If development error detection for the module Fls is enabled: the function `Fls_Read` shall check that the driver is currently not busy. If this check fails, the function `Fls_Read` shall reject the read request, raise the development error `FLS_E_BUSY` and return with `E_NOT_OK`. ] (SRS\_Fls\_12143)

**[SWS\_Fls\_00158]** [If development error detection for the module Fls is enabled: the function `Fls_Read` shall check the given data buffer pointer for not being a null pointer. If the data buffer pointer is a null pointer, the function `Fls_Read` shall reject the read request, raise the development error `FLS_E_PARAM_DATA` and return with `E_NOT_OK`. ] (SRS\_BSW\_00323)

**[SWS\_Fls\_00240]** [The FLS module's environment shall only call the function `Fls_Read` after the FLS module has been initialized. ] (SRS\_BSW\_00406)

### 8.3.8 Fls\_Compare

**[SWS\_Fls\_00257]**

<b>Service Name</b>	Fls_Compare	
<b>Syntax</b>	<pre>Std_ReturnType Fls_Compare (     Fls_AddressType SourceAddress,     const uint8* TargetAddressPtr,     Fls_LengthType Length )</pre>	
<b>Service ID [hex]</b>	0x08	
<b>Sync/Async</b>	Asynchronous	
<b>Reentrancy</b>	Non Reentrant	
<b>Parameters (in)</b>	Source Address	Source address in flash memory. This address offset will be added to the flash memory base address. Min.: 0 Max.: FLS_SIZE - 1
	Target AddressPtr	Pointer to target data buffer
	Length	Number of bytes to compare Min.: 1 Max.: FLS_SIZE - Source Address
<b>Parameters (inout)</b>	None	
<b>Parameters (out)</b>	None	
<b>Return value</b>	Std_Return-Type	E_OK: compare command has been accepted E_NOT_OK: compare command has not been accepted
<b>Description</b>	Compares the contents of an area of flash memory with that of an application data buffer.	

<b>Available via</b>	Fls_Com.h
----------------------	-----------

](SRS\_Fls\_13301)

**[SWS\_Fls\_00241]** [The function `Fls_Compare` shall compare the contents of an area of flash memory with that of an application data buffer. ] (SRS\_Fls\_13301)

**[SWS\_Fls\_00341]** [The function `Fls_Compare` shall copy the given parameters to Fls module internal variables and initiate a compare job. ] (SRS\_Fls\_13301)

**[SWS\_Fls\_00342]** [After initiating the compare job, the function `Fls_Compare` shall set the status to `MEMIF_BUSY`. ] (SRS\_Fls\_13301)

**[SWS\_Fls\_00343]** [After initiating the compare job, the function `Fls_Compare` shall set the job result to `MEMIF_JOB_PENDING`. ] (SRS\_Fls\_13301)

**[SWS\_Fls\_00344]** [After initiating the compare job, the function `Fls_Compare` shall return with `E_OK`. ] (SRS\_Fls\_13301)

**[SWS\_Fls\_00243]** [The FLS module shall execute the job of the function `Fls_Compare` asynchronously within the FLS module's main function. ] (SRS\_Fls\_13301, SRS\_Fls\_12144)

**[SWS\_Fls\_00244]** [The job of the function `Fls_Compare` shall compare a continuous flash memory block starting from `FlsBaseAddress + SourceAddress` of size `Length` with the buffer pointed to by `TargetAddressPtr`. ] (SRS\_Fls\_13301)

**[SWS\_Fls\_00150]** [If development error detection for the module Fls is enabled: the function `Fls_Compare` shall check that the compare start address (`FlsBaseAddress + SourceAddress`) lies within the specified lower and upper flash address boundaries. If this check fails, the function `Fls_Compare` shall reject the compare job, raise the development error `FLS_E_PARAM_ADDRESS` and return with `E_NOT_OK`. ] (SRS\_Fls\_13301)

**[SWS\_Fls\_00151]** [If development error detection for the module Fls is enabled: the function `Fls_Compare` shall check that the given length is greater than 0 and that the compare end address (compare start address + length) lies within the specified upper flash address boundary. If this check fails, the function `Fls_Compare` shall reject the compare job, raise the development error `FLS_E_PARAM_LENGTH` and return with `E_NOT_OK`. ] (SRS\_Fls\_13301)

**[SWS\_Fls\_00152]** [If development error detection for the module Fls is enabled: the function `Fls_Compare` shall check that the driver has been initialized. If this check fails, the function `Fls_Compare` shall reject the compare job, raise the development error `FLS_E_UNINIT` and return with `E_NOT_OK`. ] (SRS\_Fls\_13301)



**[SWS\_Fls\_00153]** [If development error detection for the module Fls is enabled: the function `Fls_Compare` shall check that the driver is currently not busy. If this check fails, the function `Fls_Compare` shall reject the compare job, raise the development error `FLS_E_BUSY` and return with `E_NOT_OK`. ] (SRS\_Fls\_13301)

**[SWS\_Fls\_00273]** [If development error detection for the module Fls is enabled: the function `Fls_Compare` shall check the given data buffer pointer for not being a null pointer. If the data buffer pointer is a null pointer, the function `Fls_Compare` shall reject the request, raise the development error `FLS_E_PARAM_DATA` and return with `E_NOT_OK`. ] (RS\_BRF\_01064)

**[SWS\_Fls\_00186]** [The function `Fls_Compare` shall be pre-compile time configurable `On/Off` by the configuration parameter `FlsCompareApi`. ] (SRS\_BSW\_00171, SRS\_Fls\_13301)

### 8.3.9 Fls\_SetMode

**[SWS\_Fls\_00258]**

<b>Service Name</b>	Fls_SetMode	
<b>Syntax</b>	<pre>void Fls_SetMode (     MemIf_ModeType Mode )</pre>	
<b>Service ID [hex]</b>	0x09	
<b>Sync/Async</b>	Synchronous	
<b>Reentrancy</b>	Non Reentrant	
<b>Parameters (in)</b>	Mode	MEMIF_MODE_SLOW: Slow read access / normal SPI access. MEMIF_MODE_FAST: Fast read access / SPI burst access.
<b>Parameters (inout)</b>	None	
<b>Parameters (out)</b>	None	
<b>Return value</b>	None	
<b>Description</b>	Sets the flash driver's operation mode.	
<b>Available via</b>	Fls.h	

](SRS\_Fls\_13302)

**[SWS\_Fls\_00155]** [The function `Fls_SetMode` shall set the FLS module's operation mode to the given "Mode" parameter. ] (SRS\_Fls\_13302)

**[SWS\_Fls\_00156]** [If development error detection for the module Fls is enabled: the function `Fls_SetMode` shall check that the FLS module is currently not busy. If this check fails, the function `Fls_SetMode` shall reject the set mode request and raise the development error code `FLS_E_BUSY`. ] (SRS\_Fls\_13302)

**[SWS\_Fls\_00187]** [The function `Fls_SetMode` shall be pre-compile time configurable On/Off by the configuration parameter `FlsSetModeApi`. ] (SRS\_BSW\_00171, SRS\_Fls\_13302)

### 8.3.10 Fls\_GetVersionInfo

**[SWS\_Fls\_00259]**[

<b>Service Name</b>	Fls_GetVersionInfo	
<b>Syntax</b>	<pre>void Fls_GetVersionInfo (     Std_VersionInfoType* VersionInfoPtr )</pre>	
<b>Service ID [hex]</b>	0x10	
<b>Sync/Async</b>	Synchronous	
<b>Reentrancy</b>	Reentrant	
<b>Parameters (in)</b>	None	
<b>Parameters (inout)</b>	None	
<b>Parameters (out)</b>	VersionInfoPtr	Pointer to where to store the version information of this module.
<b>Return value</b>	None	
<b>Description</b>	Returns the version information of this module.	
<b>Available via</b>	Fls.h	

](SRS\_BSW\_00407)

**[SWS\_Fls\_00363]**[If development error detection for the module Fls is enabled: the function `Fls_GetVersionInfo` shall raise the development error `FLS_E_PARAM_POINTER` if the argument is a NULL pointer and return without any action. ] (SRS\_BSW\_00323)

### 8.3.11 Fls\_BlankCheck

**[SWS\_Fls\_00371]**[

<b>Service Name</b>	Fls_BlankCheck	
<b>Syntax</b>	<pre>Std_ReturnType Fls_BlankCheck (     Fls_AddressType TargetAddress,     Fls_LengthType Length )</pre>	
<b>Service ID [hex]</b>	0x0a	
<b>Sync/Async</b>	Asynchronous	
<b>Reentrancy</b>	Non Reentrant	
<b>Parameters (in)</b>	TargetAddress	Address in flash memory from which the blank check should be started. Min.: 0 Max.: FLS_SIZE - 1
	Length	Number of bytes to be checked for erase pattern. Min.: 1 Max.: FLS_SIZE - TargetAddress
<b>Parameters (inout)</b>	None	
<b>Parameters (out)</b>	None	
<b>Return value</b>	Std_ReturnType	E_OK: request for blank checking has been accepted by the module E_NOT_OK: request for blank checking has not been accepted by the module
<b>Description</b>	The function Fls_BlankCheck shall verify, whether a given memory area has been erased but not (yet) programmed. The function shall limit the maximum number of checked flash cells per main function cycle to the configured value FlsMaxReadNormalMode or FlsMaxReadFastMode respectively.	
<b>Available via</b>	Fls.h	

](RS\_BRF\_01076)

**[SWS\_Fls\_00373]** [ The function Fls\_BlankCheck shall verify, whether a given memory area has been erased but not (yet) re-programmed.] **(RS\_BRF\_01076)**

**[SWS\_Fls\_00374]** [ The function Fls\_BlankCheck shall copy the given parameters to FLS module internal variables and initiate the verification job.] **(SRS\_Fls\_12144)**

**[SWS\_Fls\_00375]** [ After initiating the verification job, the function Fls\_BlankCheck shall set the FLS module status to MEMIF\_BUSY.] **(SRS\_Fls\_12144)**

**[SWS\_Fls\_00376]** [ After initiating the verification job, the function Fls\_BlankCheck shall set the FLS module job result to MEMIF\_JOB\_PENDING.] **(SRS\_Fls\_12144)**

**[SWS\_Fls\_00377]** [ After initiating the verification job, the function `Fls_BlankCheck` shall return with `E_OK`. ] **(SRS\_Fls\_12144)**

**[SWS\_Fls\_00378]** [ The FLS module shall execute the verification job of the function `Fls_BlankCheck` asynchronously within the FLS module's main function. ] **(SRS\_Fls\_12144)**

**[SWS\_Fls\_00379]** [ The verification job of the function `Fls_BlankCheck` shall check, that the continuous flash memory area starting from `FlsBaseAddress + TargetAddress` of size `Length` is erased. ] **(SRS\_Fls\_12144)**

**[SWS\_Fls\_00380]** [ If development error detection for the module FLS is enabled; the function `Fls_BlankCheck` shall check that the verification start address (`FlsBaseAddress + TargetAddress`) lies within the specified lower and upper flash address boundaries. If this check fails, the function `Fls_BlankCheck` shall reject the verification job, raise the development error `FLS_E_PARAM_ADDRESS` and return with `E_NOT_OK`. ] **(SRS\_Fls\_12159)**

**[SWS\_Fls\_00381]** [ If development error detection for the module FLS is enabled: the function `Fls_BlankCheck` shall check that the given length is greater than 0 and that the verification end address (verification start address + length) lies within the specified upper flash address boundary. If this check fails, the function `Fls_BlankCheck` shall reject the verification job, raise the development error `FLS_E_PARAM_LENGTH` and return with `E_NOT_OK`. ] **(SRS\_Fls\_12159)**

**[SWS\_Fls\_00382]** [ If development error detection for the module FLS is enabled: the function `Fls_BlankCheck` shall check that the driver has been initialized. If this check fails, the function `Fls_BlankCheck` shall reject the verification request, raise the development error `FLS_E_UNINIT` and return with `E_NOT_OK`. ] **(SRS\_BSW\_00406)**

**[SWS\_Fls\_00383]** [ If development error detection for the module FLS is enabled: the function `Fls_BlankCheck` shall check that the driver is currently not busy. If this check fails, the function `Fls_BlankCheck` shall reject the verification request, raise the development error `FLS_E_BUSY` and return with `E_NOT_OK`. ] **(SRS\_BSW\_00406)**

## 8.4 Call-back notifications

This chapter lists all functions provided by the FLS module to lower layer modules.

*Note: There are no callback functions to lower layer modules provided by the Flash Driver since this module is at the lowest (software) layer.*

**[SWS\_Fls\_00193]** [Depending on implementation, callback routines provided and/or invoked by the FLS module may be called on interrupt level. The module providing those routines has therefore to make sure that their runtime is reasonably short, i.e. since callbacks may be propagated upward through several software layers. ] (SRS\_BSW\_00164, SRS\_BSW\_00325)

## 8.5 Scheduled functions

This chapter lists all functions provided by the FLS module and called directly by the Basic Software Module Scheduler.

**[SWS\_Fls\_00269]** [The FLS module shall provide only one scheduled function. Reading from / writing to flash memory cannot usually be done simultaneously and the overhead for synchronizing two scheduled functions would outweigh the benefits. ] (SRS\_BSW\_00432)

### 8.5.1 Fls\_MainFunction

**[SWS\_Fls\_00255]**[

<b>Service Name</b>	Fls_MainFunction
<b>Syntax</b>	void Fls_MainFunction ( void )
<b>Service ID [hex]</b>	0x06
<b>Description</b>	Performs the processing of jobs.
<b>Available via</b>	SchM_Fls.h

](SRS\_Fls\_12144)

**[SWS\_Fls\_00037]** [The function `Fls_MainFunction` shall perform the processing of the flash read, write, erase and compare jobs. ] (SRS\_Fls\_12144)

**[SWS\_Fls\_00038]** [When a job has been initiated, the FLS module's environment shall call the function `Fls_MainFunction` cyclically until the job is finished. ] (SRS\_Fls\_12144)

Note: The function `Fls_MainFunction` may also be called cyclically if no job is currently pending.

**[SWS\_Fls\_00039]** [The function `Fls_MainFunction` shall return without any action if no job is pending. ] (SRS\_Fls\_12144)

**[SWS\_Fls\_00040]** [The function `Fls_MainFunction` shall only process as much data in one call cycle as statically configured for the current job type (read, write or compare) and the current FLS module's operating mode (normal, fast). ] (SRS\_Fls\_13303, SRS\_Fls\_13304, SRS\_Fls\_12145, SRS\_Fls\_12184)

**[SWS\_Fls\_00104]** [The function `Fls_MainFunction` shall set the job result to `MEMIF_JOB_FAILED` and report the error code `FLS_E_ERASE_FAILED` to the DET if a flash erase job fails due to a hardware error. ] (SRS\_BSW\_00339, SRS\_BSW\_00385, SRS\_BSW\_00466)

**[SWS\_Fls\_00105]** [The function `Fls_MainFunction` shall set the job result to `MEMIF_JOB_FAILED` and report the error code `FLS_E_WRITE_FAILED` to the DET if a flash write job fails due to a hardware error. ] (SRS\_BSW\_00339, SRS\_BSW\_00385, SRS\_BSW\_00466)

**[SWS\_Fls\_00106]** [The function `Fls_MainFunction` shall set the job result to `MEMIF_JOB_FAILED` and report the error code `FLS_E_READ_FAILED` to the DET if a flash read job fails due to a hardware error. ] (SRS\_BSW\_00339, SRS\_BSW\_00385, SRS\_BSW\_00466)

**[SWS\_Fls\_00154]** [The function `Fls_MainFunction` shall set the job result to `MEMIF_JOB_FAILED` and report the error code `FLS_E_COMPARE_FAILED` to the DET if a flash compare job fails due to a hardware error. ] (SRS\_BSW\_00339, SRS\_BSW\_00385, SRS\_BSW\_00466)

**[SWS\_Fls\_00385]:**[ If the underlying flash technology requires a certain alignment of the read address or length information and if the address and/or length parameter for a read or compare Job are not correctly aligned, the function `Fls_MainFunction` shall internally compensate for this missing alignment, that is the function `Fls_MainFunction` shall provide byte-wise read access to the flash memory, regardless of any alignment restrictions imposed by the Hardware.] (SRS\_Fls\_12135, SRS\_Fls\_12159)

**[SWS\_Fls\_00200]** [The function `Fls_MainFunction` shall set the job result to `MEMIF_BLOCK_INCONSISTENT` if the compared data from a flash compare job are not equal. ] (SRS\_Fls\_12141)

**[SWS\_Fls\_00022]** [If erase verification is enabled (compile switch `FlsEraseVerificationEnabled` set to `TRUE`): After a flash block has been erased, the function `Fls_MainFunction` shall compare the contents of the addressed memory area against the value of an erased flash cell to check that the block has been completely erased. If this check fails, the function `Fls_MainFunction` shall set the FLS module's job result to `MEMIF_JOB_FAILED` and raise the runtime error `FLS_E_VERIFY_ERASE_FAILED`.] (SRS\_Fls\_12160)

**[SWS\_Fls\_00055]** [If erase verification is enabled (compile switch `FlsEraseVerificationEnabled` set to `TRUE`): Before writing a flash block, the

function `Fls_MainFunction` shall compare the contents of the addressed memory area against the value of an erased flash cell to check that the block has been completely erased. If this check fails, the function `Fls_MainFunction` shall set the FLS module's job result to `MEMIF_JOB_FAILED` and raise the runtime error `FLS_E_VERIFY_ERASE_FAILED`. ] (SRS\_Fls\_12158)

**[SWS\_Fls\_00056]** [ If write verification is enabled (compile switch `FlsWriteVerificationEnabled` set to `TRUE`): After writing a flash block, the function `Fls_MainFunction` shall compare the contents of the reprogrammed memory area against the contents of the provided application buffer to check that the block has been completely reprogrammed. If this check fails, the function `Fls_MainFunction` shall set the FLS module's job result to `MEMIF_JOB_FAILED` and raise the runtime error `FLS_E_VERIFY_WRITE_FAILED`. ] (SRS\_Fls\_12141)

**[SWS\_Fls\_00345]** [After a read, erase, write or compare job has been finished, the function `Fls_MainFunction` shall set the FLS module's job result to `MEMIF_JOB_OK` if it is currently in state `MEMIF_JOB_PENDING`. Otherwise, it shall leave the result unchanged. ] (SRS\_Fls\_12144)

**[SWS\_Fls\_00346]** [After a read, erase, write or compare job has been finished, the function `Fls_MainFunction` shall set the FLS module's state to `MEMIF_IDLE` and call the job end notification function if configured (see [ECUC Fls\\_00307](#)). ] (SRS\_Fls\_12144)

**[SWS\_Fls\_00232]** [The configuration parameter `FlsUseInterrupts` shall switch between interrupt and polling controlled job processing if this is supported by the flash memory hardware. ] (SRS\_BSW\_00164)

**[SWS\_Fls\_00233]** [The FLS module's implementer shall locate the interrupt service routine in `Fls_Irq.c`. ] (RS\_BRF\_01144)

**[SWS\_Fls\_00234]** [If interrupt controlled job processing is supported and enabled with the configuration parameter `FlsUseInterrupts`, the interrupt service routine shall reset the interrupt flag, check for errors reported by the underlying hardware, reload the hardware finite state machine for the next round of the pending job or call the appropriate notification routine if the job is finished or aborted. ] (RS\_BRF\_01144)

**[SWS\_Fls\_00235]** [The function `Fls_MainFunction` shall process jobs without hardware interrupt support (e.g. read jobs). ] (SRS\_Fls\_12144)

**[SWS\_Fls\_00272]** [If timeout supervision is enabled (compile switch `FlsTimeoutSupervisionEnabled` set to `TRUE`): the function `Fls_MainFunction` shall provide a timeout monitoring for the currently running job, that is it shall supervise the deadline of the read / compare / erase or write job. ] (SRS\_Fls\_12144, RS\_BRF\_01076)

**[SWS\_Fls\_00359]** [If timeout supervision is enabled (compile switch `FlsTimeoutSupervisionEnabled` set to `TRUE`): the function `Fls_MainFunction` shall check, whether the configured maximum erase time (see [ECUC Fls\\_00298](#) `FlsEraseTime`) has been exceeded. If this is the case, the function `Fls_MainFunction` shall raise the runtime error `FLS_E_TIMEOUT`. ] (RS\_BRF\_01076)

**[SWS\_Fls\_00360]** [If timeout supervision is enabled (compile switch `FlsTimeoutSupervisionEnabled` set to `TRUE`): the function `Fls_MainFunction` shall check, whether the expected maximum write time (see note below) has been exceeded. If this is the case, the function `Fls_MainFunction` shall raise the runtime error `FLS_E_TIMEOUT`. ] (RS\_BRF\_01076)

*Note: The expected maximum write time depends on the current mode of the Fls module (see [SWS Fls\\_00258](#)), the configured number of bytes to write in this mode (see [ECUC Fls\\_00278](#) and [ECUC Fls\\_00277](#) respectively), the size of a single flash page (see [ECUC Fls\\_00281](#)) and last the maximum time to write one flash page (see [ECUC Fls\\_00301](#)). The number of bytes to write divided by the size of one flash page yields the number of pages to write in one cycle. This multiplied with the maximum write time for one flash page gives you the expected maximum write time.*

**[SWS\_Fls\_00362]** [If timeout supervision is enabled (compile switch `FlsTimeoutSupervisionEnabled` set to `TRUE`): the function `Fls_MainFunction` shall check, whether the expected maximum read / compare time (see note below) has been exceeded. If this is the case, the function `Fls_MainFunction` shall raise the runtime error `FLS_E_TIMEOUT`. ] (RS\_BRF\_01076)

*Note: There are no published timings for read / compare (these would mostly depend on whether the flash device is internal or external e.g. connected via SPI). The solution would be similar as for write jobs above: the configured number of bytes to read (and to compare) is coupled to the expected read / compare times which should be supervised by the `Fls_MainFunction`. If this is not detailed enough there are two possibilities:*

- *specify expected read / compare times (difficult because of the dependency mentioned above)*
- *leave read / compare jobs out of the timeout supervision (change [SWS\\_Fls\\_00272](#)).*

**[SWS\_Fls\_00196]** [The function `Fls_MainFunction` shall at the most issue one sector erase command (to the hardware) in each cycle. ] (SRS\_Fls\_12144)

*Note: The requirement above shall ensure that maximum one sector is erased sequentially within one cycle of the driver's main function. If the hardware is capable of erasing more than one sector in parallel, this shall not be restricted by this specification.*



## 8.6 Expected Interfaces

This chapter lists all functions the Fls module requires from other modules.

### 8.6.1 Mandatory Interfaces

This chapter defines all interfaces which are required to fulfill the core functionality of the module.

#### [SWS\_Fls\_00260]

<i>API Function</i>	<i>Header File</i>	<i>Description</i>
Det_Report- RuntimeError	Det.h	Service to report runtime errors. If a callout has been configured then this callout shall be called.

](SRS\_BSW\_00469, SRS\_BSW\_00339)

*Note: If the flash device is connected via SPI, also the SPI interfaces are required to fulfill the modules core functionality. Which interfaces are needed exactly shall not be detailed further in this specification.*

### 8.6.2 Optional Interfaces

This chapter defines all interfaces which are required to fulfill an optional functionality of the module.

#### [SWS\_Fls\_00261]

<i>API Function</i>	<i>Header File</i>	<i>Description</i>
Det_ReportError	Det.h	Service to report development errors.

]()

### 8.6.3 Configurable interfaces

In this chapter, all interfaces are listed for which the target function can be configured. The target function is usually a call-back function. The names of these kind of interfaces is not fixed because they are configurable.

**[SWS\_Fls\_00109]** [The job processing callback notifications shall be configurable as function pointers within the initialization data structure (`Fls_ConfigType`). ] (RS\_BRF\_01064 )

**[SWS\_Fls\_00110]** [The callback notifications shall have no parameters and no return value. ] (RS\_BRF\_01064)

**[SWS\_Fls\_00262]**

<b>Service Name</b>	Fee_JobEndNotification
<b>Syntax</b>	void Fee_JobEndNotification ( void )
<b>Sync/Async</b>	Synchronous
<b>Reentrancy</b>	Don't care
<b>Parameters (in)</b>	None
<b>Parameters (inout)</b>	None
<b>Parameters (out)</b>	None
<b>Return value</b>	None
<b>Description</b>	This callback function is called when a job has been completed with a positive result.
<b>Available via</b>	Fee.h

|(RS\_BRF\_01064)

**[SWS\_Fls\_00167]** [The FLS module shall call the callback function `Fee_JobEndNotification` when the module has completed a job with a positive result:

- Read job finished & OK
- Write job finished & OK
- Erase job finished & OK
- Compare job finished & memory blocks are the same | (RS\_BRF\_01064)

**[SWS\_Fls\_00263]**

<b>Service Name</b>	Fee_JobErrorNotification
<b>Syntax</b>	void Fee_JobErrorNotification ( void )
<b>Sync/Async</b>	Synchronous
<b>Reentrancy</b>	Don't care
<b>Parameters (in)</b>	None
<b>Parameters (inout)</b>	None
<b>Parameters (out)</b>	None
<b>Return value</b>	None
<b>Description</b>	This callback function is called when a job has been canceled or finished with

	negative result.
<b>Available via</b>	Fee.h

](RS\_BRF\_01064)

**[SWS\_Fls\_00347]** [The FLS module shall call the callback function `Fee_JobErrorNotification` when the module has finished a job with a negative result:

- Read job failed
- Write job failed
- Erase job failed
- Compare job failed] (RS\_BRF\_01064)

**[SWS\_Fls\_00348]** [The FLS module shall call the callback function `Fee_JobErrorNotification` when the module has canceled an ongoing job:

- Read job aborted
- Write job aborted
- Erase job aborted
- Compare job aborted] (RS\_BRF\_01064)

**[SWS\_Fls\_00349]** [The FLS module shall call the callback function `Fee_JobErrorNotification` when the module has finished a compare job and the memory blocks differ:

- Compare job finished and memory blocks differ] (RS\_BRF\_01064)

## 9 Sequence diagrams

### 9.1 Initialization

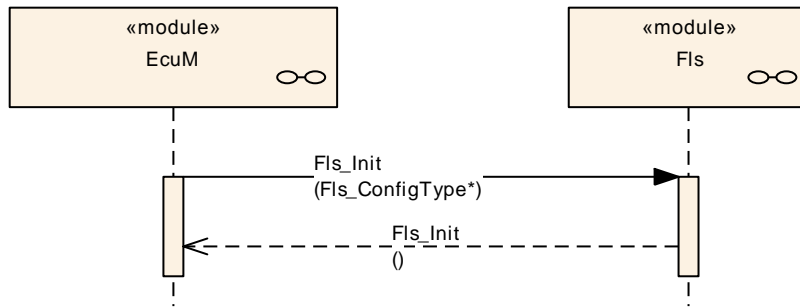

Figure 1: Flash driver initialization sequence

### 9.2 Synchronous functions

The following sequence diagram shows the function `Fls_GetJobResult` as an example for the synchronous functions of this module. The same sequence applies also to the functions `Fls_GetStatus` and `Fls_SetMode`.

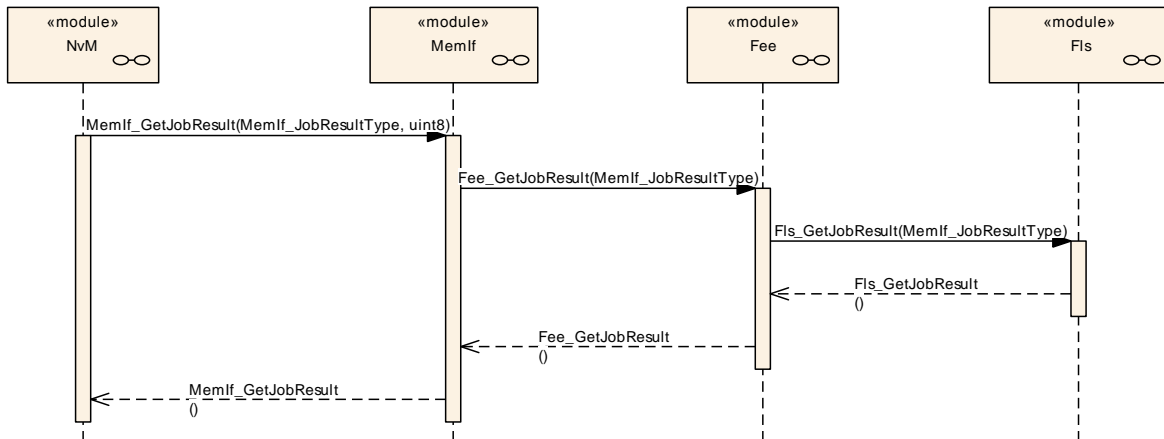

Figure 2: `Fls_GetJobResult`

### 9.3 Asynchronous functions

The following sequence diagram shows the flash write function (with the configuration option `FlsAcLoadOnJobStart` set) as an example for the asynchronous functions of this module. The same sequence applies to the erase, read and compare jobs, with the only difference that for the read and compare jobs no flash access code needs to be loaded to / unloaded from RAM.

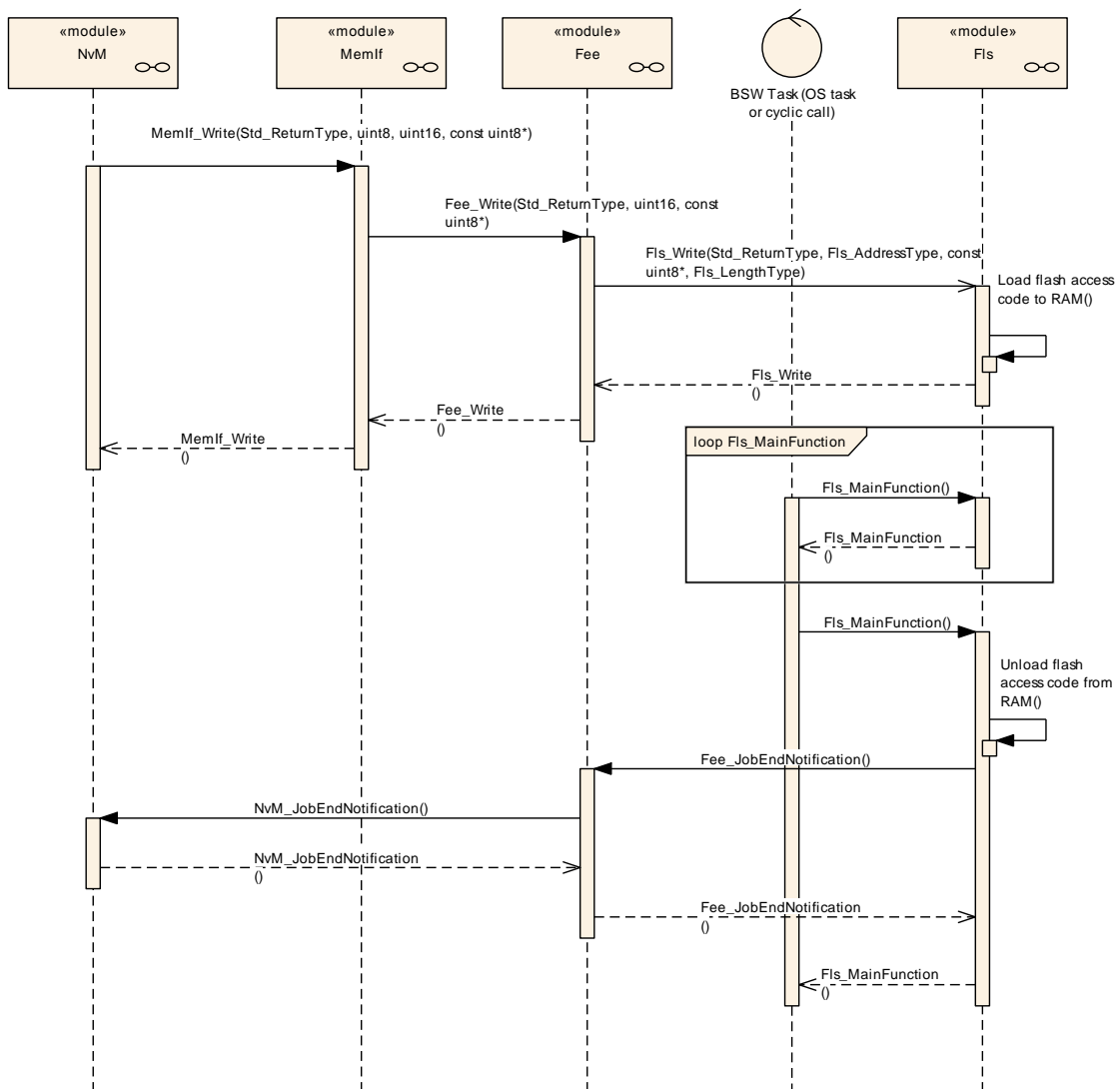
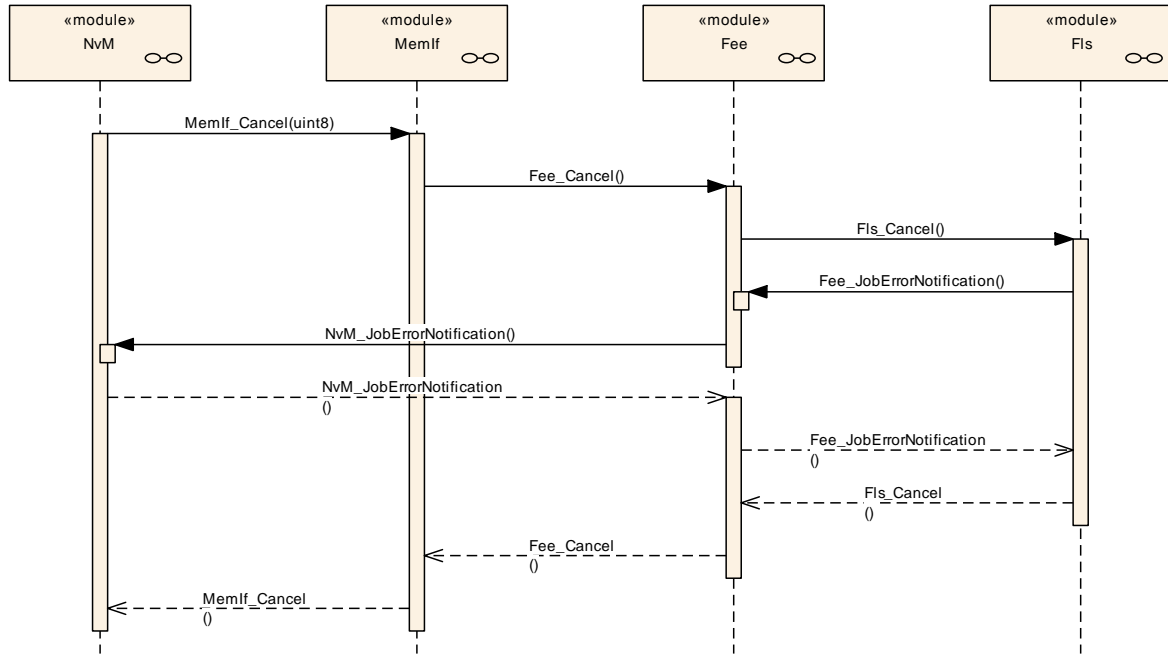

Figure 3: Flash write sequence, flash access code loaded on job start

### 9.4 Canceling a running job



**Figure 4: Canceling a running flash job**

**Note:** The FLS module’s environment shall not call the function *Fls\_Cancel* during a running *Fls\_MainFunction* invocation.

This can be achieved by one of the following scheduling configurations:

- Possibility 1: The job functions of the NVRAM manager and the flash driver are synchronized (e.g. called sequentially within one task)
- Possibility 2: The task that calls the *Fls\_MainFunction* function can not be preempted by another task.

## 10 Configuration specification

### 10.1 Containers and configuration parameters

The following chapters summarize all configuration parameters.

#### 10.1.1 Fls

<b>SWS Item</b>	<b>ECUC_Fls_00001 :</b>
<b>Module Name</b>	<i>Fls</i>
<b>Module Description</b>	Configuration of the Fls (internal or external flash driver) module. Its multiplicity describes the number of flash drivers present, so there will be one container for each flash driver in the ECUC template. When no flash driver is present then the multiplicity is 0.
<b>Post-Build Variant Support</b>	true
<b>Supported Config Variants</b>	VARIANT-POST-BUILD, VARIANT-PRE-COMPILE

<b>Included Containers</b>		
<b>Container Name</b>	<b>Multiplicity</b>	<b>Scope / Dependency</b>
FlsConfigSet	1	Container for runtime configuration parameters of the flash driver. Implementation Type: Fls_ConfigType.
FlsGeneral	1	Container for general parameters of the flash driver. These parameters are always pre-compile.
FlsPublishedInformation	1	Additional published parameters not covered by CommonPublishedInformation container. Note that these parameters do not have any configuration class setting, since they are published information.

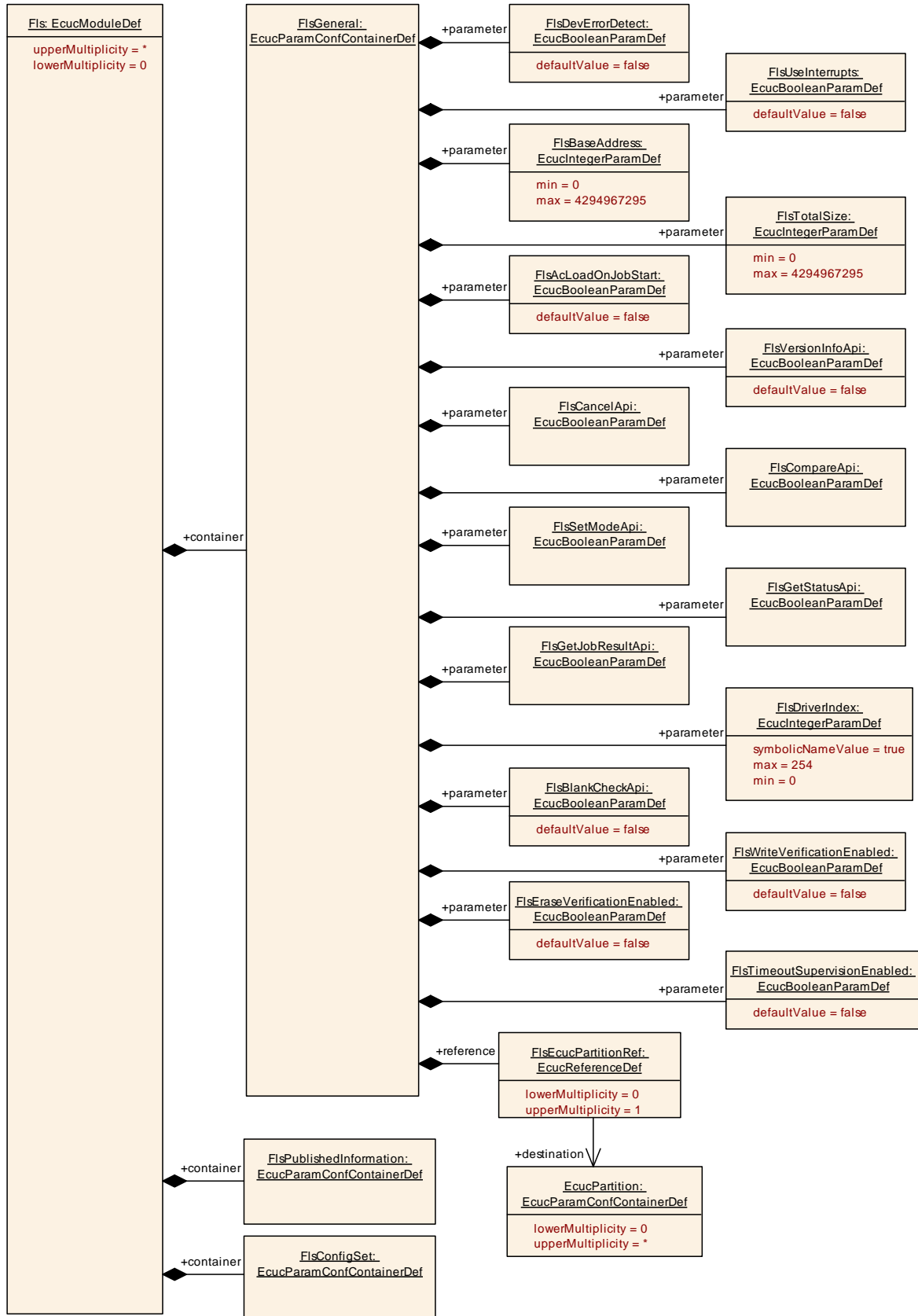

Figure 5: Configuration of the Fls



## 10.1.2 FlsGeneral

<b>SWS Item</b>	<b>ECUC_Fls_00172 :</b>
<b>Container Name</b>	FlsGeneral
<b>Parent Container</b>	Fls
<b>Description</b>	Container for general parameters of the flash driver. These parameters are always pre-compile.
<b>Configuration Parameters</b>	

<b>SWS Item</b>	<b>ECUC_Fls_00284 :</b>		
<b>Name</b>	FlsAcLoadOnJobStart		
<b>Parent Container</b>	FlsGeneral		
<b>Description</b>	The flash driver shall load the flash access code to RAM whenever an erase or write job is started and unload (overwrite) it after that job has been finished or canceled. true: Flash access code loaded on job start / unloaded on job end or error. false: Flash access code not loaded to / unloaded from RAM at all.		
<b>Multiplicity</b>	1		
<b>Type</b>	EcucBooleanParamDef		
<b>Default value</b>	false		
<b>Post-Build Variant Value</b>	false		
<b>Value Configuration Class</b>	<b>Pre-compile time</b>	X	All Variants
	<b>Link time</b>	--	
	<b>Post-build time</b>	--	
<b>Scope / Dependency</b>	scope: local		

<b>SWS Item</b>	<b>ECUC_Fls_00169 :</b>		
<b>Name</b>	FlsBaseAddress		
<b>Parent Container</b>	FlsGeneral		
<b>Description</b>	The flash memory start address (see also SWS_Fls_00208 and SWS_Fls_00209). This parameter defines the lower boundary for read / write / erase and compare jobs.		
<b>Multiplicity</b>	1		
<b>Type</b>	EcucIntegerParamDef		
<b>Range</b>	0 .. 4294967295		
<b>Default value</b>	--		
<b>Post-Build Variant Value</b>	false		
<b>Value Configuration Class</b>	<b>Pre-compile time</b>	X	All Variants
	<b>Link time</b>	--	
	<b>Post-build time</b>	--	
<b>Scope / Dependency</b>	scope: local		

<b>SWS Item</b>	<b>ECUC_Fls_00319 :</b>		
<b>Name</b>	FlsBlankCheckApi		
<b>Parent Container</b>	FlsGeneral		
<b>Description</b>	Compile switch to enable/disable the Fls_BlankCheck function. true: API supported / function provided. false: API not supported / function not provided		
<b>Multiplicity</b>	1		
<b>Type</b>	EcucBooleanParamDef		
<b>Default value</b>	false		
<b>Post-Build Variant Value</b>	false		
<b>Value Configuration Class</b>	<b>Pre-compile time</b>	X	All Variants
	<b>Link time</b>	--	

	<b>Post-build time</b>	--	
<b>Scope / Dependency</b>	scope: local		

<b>SWS Item</b>	<b>ECUC_FIs_00285 :</b>		
<b>Name</b>	FIsCancelApi		
<b>Parent Container</b>	FIsGeneral		
<b>Description</b>	Compile switch to enable and disable the FIs_Cancel function. true: API supported / function provided. false: API not supported / function not provided		
<b>Multiplicity</b>	1		
<b>Type</b>	EcucBooleanParamDef		
<b>Default value</b>	--		
<b>Post-Build Variant Value</b>	false		
<b>Value Configuration Class</b>	<b>Pre-compile time</b>	X	All Variants
	<b>Link time</b>	--	
	<b>Post-build time</b>	--	
<b>Scope / Dependency</b>	scope: local		

<b>SWS Item</b>	<b>ECUC_FIs_00286 :</b>		
<b>Name</b>	FIsCompareApi		
<b>Parent Container</b>	FIsGeneral		
<b>Description</b>	Compile switch to enable and disable the FIs_Compare function. true: API supported / function provided. false: API not supported / function not provided		
<b>Multiplicity</b>	1		
<b>Type</b>	EcucBooleanParamDef		
<b>Default value</b>	--		
<b>Post-Build Variant Value</b>	false		
<b>Value Configuration Class</b>	<b>Pre-compile time</b>	X	All Variants
	<b>Link time</b>	--	
	<b>Post-build time</b>	--	
<b>Scope / Dependency</b>	scope: local		

<b>SWS Item</b>	<b>ECUC_FIs_00287 :</b>		
<b>Name</b>	FIsDevErrorDetect		
<b>Parent Container</b>	FIsGeneral		
<b>Description</b>	Switches the development error detection and notification on or off. <ul style="list-style-type: none"> <li>• true: detection and notification is enabled.</li> <li>• false: detection and notification is disabled.</li> </ul>		
<b>Multiplicity</b>	1		
<b>Type</b>	EcucBooleanParamDef		
<b>Default value</b>	false		
<b>Post-Build Variant Value</b>	false		
<b>Value Configuration Class</b>	<b>Pre-compile time</b>	X	All Variants
	<b>Link time</b>	--	
	<b>Post-build time</b>	--	
<b>Scope / Dependency</b>	scope: local		

<b>SWS Item</b>	<b>ECUC_FIs_00288 :</b>		
<b>Name</b>	FIsDriverIndex		
<b>Parent Container</b>	FIsGeneral		
<b>Description</b>	Index of the driver, used by FEE.		
<b>Multiplicity</b>	1		
<b>Type</b>	EcucIntegerParamDef (Symbolic Name generated for this parameter)		

<b>Range</b>	0 .. 254		
<b>Default value</b>	--		
<b>Post-Build Variant Value</b>	false		
<b>Value Configuration Class</b>	<b>Pre-compile time</b>	X	All Variants
	<b>Link time</b>	--	
	<b>Post-build time</b>	--	
<b>Scope / Dependency</b>	scope: ECU		

<b>SWS Item</b>	<b>ECUC_FIs_00321 :</b>		
<b>Name</b>	FIsEraseVerificationEnabled		
<b>Parent Container</b>	FIsGeneral		
<b>Description</b>	Compile switch to enable erase verification. true: memory region is checked to be erased. false: memory region is not checked to be erased.		
<b>Multiplicity</b>	1		
<b>Type</b>	EcucBooleanParamDef		
<b>Default value</b>	false		
<b>Post-Build Variant Value</b>	false		
<b>Value Configuration Class</b>	<b>Pre-compile time</b>	X	All Variants
	<b>Link time</b>	--	
	<b>Post-build time</b>	--	
<b>Scope / Dependency</b>	scope: local		

<b>SWS Item</b>	<b>ECUC_FIs_00289 :</b>		
<b>Name</b>	FIsGetJobResultApi		
<b>Parent Container</b>	FIsGeneral		
<b>Description</b>	Compile switch to enable and disable the FIs_GetJobResult function. true: API supported / function provided. false: API not supported / function not provided		
<b>Multiplicity</b>	1		
<b>Type</b>	EcucBooleanParamDef		
<b>Default value</b>	--		
<b>Post-Build Variant Value</b>	false		
<b>Value Configuration Class</b>	<b>Pre-compile time</b>	X	All Variants
	<b>Link time</b>	--	
	<b>Post-build time</b>	--	
<b>Scope / Dependency</b>	scope: local		

<b>SWS Item</b>	<b>ECUC_FIs_00290 :</b>		
<b>Name</b>	FIsGetStatusApi		
<b>Parent Container</b>	FIsGeneral		
<b>Description</b>	Compile switch to enable and disable the FIs_GetStatus function. true: API supported / function provided. false: API not supported / function not provided		
<b>Multiplicity</b>	1		
<b>Type</b>	EcucBooleanParamDef		
<b>Default value</b>	--		
<b>Post-Build Variant Value</b>	false		
<b>Value Configuration Class</b>	<b>Pre-compile time</b>	X	All Variants
	<b>Link time</b>	--	
	<b>Post-build time</b>	--	
<b>Scope / Dependency</b>	scope: local		

<b>SWS Item</b>	<b>ECUC_FIs_00291 :</b>		
<b>Name</b>	FIsSetModeApi		
<b>Parent Container</b>	FIsGeneral		

<b>Description</b>	Compile switch to enable and disable the Fls_SetMode function. true: API supported / function provided. false: API not supported / function not provided		
<b>Multiplicity</b>	1		
<b>Type</b>	EcucBooleanParamDef		
<b>Default value</b>	--		
<b>Post-Build Variant Value</b>	false		
<b>Value Configuration Class</b>	<b>Pre-compile time</b>	X	All Variants
	<b>Link time</b>	--	
	<b>Post-build time</b>	--	
<b>Scope / Dependency</b>	scope: local		

<b>SWS Item</b>	<b>ECUC_Fls_00322 :</b>		
<b>Name</b>	FlsTimeoutSupervisionEnabled		
<b>Parent Container</b>	FlsGeneral		
<b>Description</b>	Compile switch to enable timeout supervision. true: timeout supervision for read/erase/write/compare jobs enabled. false: timeout supervision for read/erase/write/compare jobs disabled.		
<b>Multiplicity</b>	1		
<b>Type</b>	EcucBooleanParamDef		
<b>Default value</b>	false		
<b>Post-Build Variant Value</b>	false		
<b>Value Configuration Class</b>	<b>Pre-compile time</b>	X	All Variants
	<b>Link time</b>	--	
	<b>Post-build time</b>	--	
<b>Scope / Dependency</b>	scope: local		

<b>SWS Item</b>	<b>ECUC_Fls_00170 :</b>		
<b>Name</b>	FlsTotalSize		
<b>Parent Container</b>	FlsGeneral		
<b>Description</b>	The total amount of flash memory in bytes (see also SWS_Fls_00208 and SWS_Fls_00209). This parameter in conjunction with FLS_BASE_ADDRESS defines the upper boundary for read / write / erase and compare jobs.		
<b>Multiplicity</b>	1		
<b>Type</b>	EcucIntegerParamDef		
<b>Range</b>	0 .. 4294967295		
<b>Default value</b>	--		
<b>Post-Build Variant Value</b>	false		
<b>Value Configuration Class</b>	<b>Pre-compile time</b>	X	All Variants
	<b>Link time</b>	--	
	<b>Post-build time</b>	--	
<b>Scope / Dependency</b>	scope: local		

<b>SWS Item</b>	<b>ECUC_Fls_00292 :</b>		
<b>Name</b>	FlsUseInterrupts		
<b>Parent Container</b>	FlsGeneral		
<b>Description</b>	Job processing triggered by hardware interrupt. true: Job processing triggered by interrupt (hardware controlled). false: Job processing not triggered by interrupt (software controlled) or the underlying hardware does not support interrupt mode for flash operations.		
<b>Multiplicity</b>	1		
<b>Type</b>	EcucBooleanParamDef		
<b>Default value</b>	false		
<b>Post-Build Variant Value</b>	false		
<b>Value Configuration Class</b>	<b>Pre-compile time</b>	X	All Variants
	<b>Link time</b>	--	
	<b>Post-build time</b>	--	

	<b>Link time</b>	--	
	<b>Post-build time</b>	--	
<b>Scope / Dependency</b>	scope: local dependency: Only available if supported by underlying flash hardware		

<b>SWS Item</b>	<b>ECUC_FIs_00293 :</b>		
<b>Name</b>	FIsVersionInfoApi		
<b>Parent Container</b>	FIsGeneral		
<b>Description</b>	Pre-processor switch to enable / disable the API to read out the modules version information. true: Version info API enabled. false: Version info API disabled.		
<b>Multiplicity</b>	1		
<b>Type</b>	EcucBooleanParamDef		
<b>Default value</b>	false		
<b>Post-Build Variant Value</b>	false		
<b>Value Configuration Class</b>	<b>Pre-compile time</b>	X	All Variants
	<b>Link time</b>	--	
	<b>Post-build time</b>	--	
<b>Scope / Dependency</b>	scope: local		

<b>SWS Item</b>	<b>ECUC_FIs_00320 :</b>		
<b>Name</b>	FIsWriteVerificationEnabled		
<b>Parent Container</b>	FIsGeneral		
<b>Description</b>	Compile switch to enable write verification. true: written data is compared directly after write. false: written date is not compared directly after write.		
<b>Multiplicity</b>	1		
<b>Type</b>	EcucBooleanParamDef		
<b>Default value</b>	false		
<b>Post-Build Variant Value</b>	false		
<b>Value Configuration Class</b>	<b>Pre-compile time</b>	X	All Variants
	<b>Link time</b>	--	
	<b>Post-build time</b>	--	
<b>Scope / Dependency</b>	scope: local		

<b>SWS Item</b>	<b>ECUC_FIs_00323 :</b>		
<b>Name</b>	FIsEcucPartitionRef		
<b>Parent Container</b>	FIsGeneral		
<b>Description</b>	Maps the Flash driver to zero or one ECUC partition to make the driver API available in this partition.		
<b>Multiplicity</b>	0..1		
<b>Type</b>	Reference to [ EcucPartition ]		
<b>Post-Build Variant Value</b>	true		
<b>Multiplicity Configuration Class</b>	<b>Pre-compile time</b>	X	All Variants
	<b>Link time</b>	--	
	<b>Post-build time</b>	--	
<b>Value Configuration Class</b>	<b>Pre-compile time</b>	X	All Variants
	<b>Link time</b>	--	
	<b>Post-build time</b>	--	
<b>Scope / Dependency</b>	scope: ECU		

<b>No Included Containers</b>
-------------------------------

### 10.1.3 FlsConfigSet

<b>SWS Item</b>	<b>ECUC_Fls_00174 :</b>
<b>Container Name</b>	FlsConfigSet
<b>Parent Container</b>	Fls
<b>Description</b>	Container for runtime configuration parameters of the flash driver. Implementation Type: Fls_ConfigType.
<b>Configuration Parameters</b>	

<b>SWS Item</b>	<b>ECUC_Fls_00270 :</b>		
<b>Name</b>	FlsAcErase		
<b>Parent Container</b>	FlsConfigSet		
<b>Description</b>	Address offset in RAM to which the erase flash access code shall be loaded. Used as function pointer to access the erase flash access code.		
<b>Multiplicity</b>	1		
<b>Type</b>	EcucIntegerParamDef		
<b>Range</b>	0 .. 4294967295		
<b>Default value</b>	--		
<b>Post-Build Variant Value</b>	true		
<b>Value Configuration Class</b>	<b>Pre-compile time</b>	X	VARIANT-PRE-COMPILE
	<b>Link time</b>	--	
	<b>Post-build time</b>	X	VARIANT-POST-BUILD
<b>Scope / Dependency</b>	scope: local		

<b>SWS Item</b>	<b>ECUC_Fls_00305 :</b>		
<b>Name</b>	FlsAcWrite		
<b>Parent Container</b>	FlsConfigSet		
<b>Description</b>	Address offset in RAM to which the write flash access code shall be loaded. Used as function pointer to access the write flash access code.		
<b>Multiplicity</b>	1		
<b>Type</b>	EcucIntegerParamDef		
<b>Range</b>	0 .. 4294967295		
<b>Default value</b>	--		
<b>Post-Build Variant Value</b>	true		
<b>Value Configuration Class</b>	<b>Pre-compile time</b>	X	VARIANT-PRE-COMPILE
	<b>Link time</b>	--	
	<b>Post-build time</b>	X	VARIANT-POST-BUILD
<b>Scope / Dependency</b>	scope: local		

<b>SWS Item</b>	<b>ECUC_Fls_00306 :</b>		
<b>Name</b>	FlsCallCycle		
<b>Parent Container</b>	FlsConfigSet		
<b>Description</b>	Cycle time of calls of the flash driver's main function (in seconds).		
<b>Multiplicity</b>	1		
<b>Type</b>	EcucFloatParamDef		
<b>Range</b>	]0 .. INF[		
<b>Default value</b>	--		
<b>Post-Build Variant Value</b>	true		
<b>Value Configuration Class</b>	<b>Pre-compile time</b>	X	VARIANT-PRE-COMPILE
	<b>Link time</b>	--	

	<b>Post-build time</b>	X	VARIANT-POST-BUILD
<b>Scope / Dependency</b>	scope: local dependency: Only relevant if deadline monitoring for internal functionality has to be done in software (e.g. erase / write timings)		

<b>SWS Item</b>	<b>ECUC_Fls_00318 :</b>		
<b>Name</b>	FlsDefaultMode		
<b>Parent Container</b>	FlsConfigSet		
<b>Description</b>	This parameter is the default FLS device mode after initialization. Implementation Type: MemIf_ModeType.		
<b>Multiplicity</b>	1		
<b>Type</b>	EcucEnumerationParamDef		
<b>Range</b>	MEMIF_MODE_FAST	The driver is working in fast mode (fast read access / SPI burst access).	
	MEMIF_MODE_SLOW	The driver is working in slow mode.	
<b>Default value</b>	MEMIF_MODE_SLOW		
<b>Post-Build Variant Value</b>	true		
<b>Value Configuration Class</b>	<b>Pre-compile time</b>	X	VARIANT-PRE-COMPILE
	<b>Link time</b>	--	
	<b>Post-build time</b>	X	VARIANT-POST-BUILD
<b>Scope Dependency</b>	scope: local		

<b>SWS Item</b>	<b>ECUC_Fls_00307 :</b>		
<b>Name</b>	FlsJobEndNotification		
<b>Parent Container</b>	FlsConfigSet		
<b>Description</b>	Mapped to the job end notification routine provided by some upper layer module, typically the Fee module.		
<b>Multiplicity</b>	0..1		
<b>Type</b>	EcucFunctionNameDef		
<b>Default value</b>	--		
<b>maxLength</b>	--		
<b>minLength</b>	--		
<b>regularExpression</b>	--		
<b>Post-Build Variant Multiplicity</b>	true		
<b>Post-Build Variant Value</b>	true		
<b>Multiplicity Configuration Class</b>	<b>Pre-compile time</b>	X	VARIANT-PRE-COMPILE
	<b>Link time</b>	--	
	<b>Post-build time</b>	X	VARIANT-POST-BUILD
<b>Value Configuration Class</b>	<b>Pre-compile time</b>	X	VARIANT-PRE-COMPILE
	<b>Link time</b>	--	
	<b>Post-build time</b>	X	VARIANT-POST-BUILD
<b>Scope / Dependency</b>	scope: local		

<b>SWS Item</b>	<b>ECUC_Fls_00274 :</b>		
<b>Name</b>	FlsJobErrorNotification		
<b>Parent Container</b>	FlsConfigSet		
<b>Description</b>	Mapped to the job error notification routine provided by some upper layer module, typically the Fee module.		
<b>Multiplicity</b>	0..1		
<b>Type</b>	EcucFunctionNameDef		
<b>Default value</b>	--		
<b>maxLength</b>	--		
<b>minLength</b>	--		

<b>regularExpression</b>	--		
<b>Post-Build Variant Multiplicity</b>	true		
<b>Post-Build Variant Value</b>	true		
<b>Multiplicity Configuration Class</b>	<b>Pre-compile time</b>	X	VARIANT-PRE-COMPILE
	<b>Link time</b>	--	
	<b>Post-build time</b>	X	VARIANT-POST-BUILD
<b>Value Configuration Class</b>	<b>Pre-compile time</b>	X	VARIANT-PRE-COMPILE
	<b>Link time</b>	--	
	<b>Post-build time</b>	X	VARIANT-POST-BUILD
<b>Scope / Dependency</b>	scope: local		

<b>SWS Item</b>	<b>ECUC_Fls_00275 :</b>		
<b>Name</b>	FIsMaxReadFastMode		
<b>Parent Container</b>	FIsConfigSet		
<b>Description</b>	The maximum number of bytes to read or compare in one cycle of the flash driver's job processing function in fast mode.		
<b>Multiplicity</b>	1		
<b>Type</b>	EcucIntegerParamDef		
<b>Range</b>	0 .. 4294967295		
<b>Default value</b>	--		
<b>Post-Build Variant Value</b>	true		
<b>Value Configuration Class</b>	<b>Pre-compile time</b>	X	VARIANT-PRE-COMPILE
	<b>Link time</b>	--	
	<b>Post-build time</b>	X	VARIANT-POST-BUILD
<b>Scope / Dependency</b>	scope: local dependency: The minimum number might depend on the underlying flash device or communication driver, e.g. if the access to an external flash device is done via SPI and the minimum transfer size on SPI is four bytes.		

<b>SWS Item</b>	<b>ECUC_Fls_00276 :</b>		
<b>Name</b>	FIsMaxReadNormalMode		
<b>Parent Container</b>	FIsConfigSet		
<b>Description</b>	The maximum number of bytes to read or compare in one cycle of the flash driver's job processing function in normal mode.		
<b>Multiplicity</b>	1		
<b>Type</b>	EcucIntegerParamDef		
<b>Range</b>	0 .. 4294967295		
<b>Default value</b>	--		
<b>Post-Build Variant Value</b>	true		
<b>Value Configuration Class</b>	<b>Pre-compile time</b>	X	VARIANT-PRE-COMPILE
	<b>Link time</b>	--	
	<b>Post-build time</b>	X	VARIANT-POST-BUILD
<b>Scope / Dependency</b>	scope: local dependency: The minimum number might depend on the underlying flash device or communication driver, e.g. if the access to an external flash device is done via SPI and the minimum transfer size on SPI is four bytes.		

<b>SWS Item</b>	<b>ECUC_Fls_00277 :</b>		
<b>Name</b>	FIsMaxWriteFastMode		
<b>Parent Container</b>	FIsConfigSet		
<b>Description</b>	The maximum number of bytes to write in one cycle of the flash driver's job processing function in fast mode.		
<b>Multiplicity</b>	1		
<b>Type</b>	EcucIntegerParamDef		
<b>Range</b>	0 .. 4294967295		



<b>Default value</b>	--		
<b>Post-Build Variant Value</b>	true		
<b>Value Configuration Class</b>	<b>Pre-compile time</b>	X	VARIANT-PRE-COMPILE
	<b>Link time</b>	--	
	<b>Post-build time</b>	X	VARIANT-POST-BUILD
<b>Scope / Dependency</b>	scope: local dependency: FLS182: This value has to correspond to the settings in FLS_PAGE_LIST. The minimum number is defined by the size of one flash page and therefore depends on the underlying flash device.		

<b>SWS Item</b>	<b>ECUC_Fls_00278 :</b>		
<b>Name</b>	FlsMaxWriteNormalMode		
<b>Parent Container</b>	FlsConfigSet		
<b>Description</b>	The maximum number of bytes to write in one cycle of the flash driver's job processing function in normal mode.		
<b>Multiplicity</b>	1		
<b>Type</b>	EcuIntegerParamDef		
<b>Range</b>	0 .. 4294967295		
<b>Default value</b>	--		
<b>Post-Build Variant Value</b>	true		
<b>Value Configuration Class</b>	<b>Pre-compile time</b>	X	VARIANT-PRE-COMPILE
	<b>Link time</b>	--	
	<b>Post-build time</b>	X	VARIANT-POST-BUILD
<b>Scope / Dependency</b>	scope: local dependency: This value has to correspond to the settings in FLS_PAGE_LIST. The minimum number is defined by the size of one flash page and therefore depends on the underlying flash device.		

<b>SWS Item</b>	<b>ECUC_Fls_00279 :</b>		
<b>Name</b>	FlsProtection		
<b>Parent Container</b>	FlsConfigSet		
<b>Description</b>	Erase/write protection settings. Only relevant if supported by hardware.		
<b>Multiplicity</b>	1		
<b>Type</b>	EcuIntegerParamDef		
<b>Range</b>	0 .. 4294967295		
<b>Default value</b>	--		
<b>Post-Build Variant Value</b>	true		
<b>Value Configuration Class</b>	<b>Pre-compile time</b>	X	VARIANT-PRE-COMPILE
	<b>Link time</b>	--	
	<b>Post-build time</b>	X	VARIANT-POST-BUILD
<b>Scope / Dependency</b>	scope: local dependency: Only relevant if supported by hardware.		

<b>Included Containers</b>		
<b>Container Name</b>	<b>Multiplicity</b>	<b>Scope / Dependency</b>
FlsExternalDriver	0..1	This container is present for external Flash drivers only. Internal Flash drivers do not use the parameter listed in this container, hence its multiplicity is 0 for internal drivers.
FlsSectorList	1	List of flashable sectors and pages.

**[SWS\_Fls\_00352]** [The table above specifies the parameters that shall be located in an external data structure of type `Fls_ConfigType`. ] (SRS\_BSW\_00438, SRS\_BSW\_00388)

[SWS\_Fls\_00353] [The organization and location of the data structure Fls\_ConfigType shall be up to the implementer. ] (SRS\_BSW\_00438)

[SWS\_Fls\_00355] [Hardware or implementation specific parameters can be added to Fls\_ConfigType if necessary. ] (SRS\_BSW\_00438)

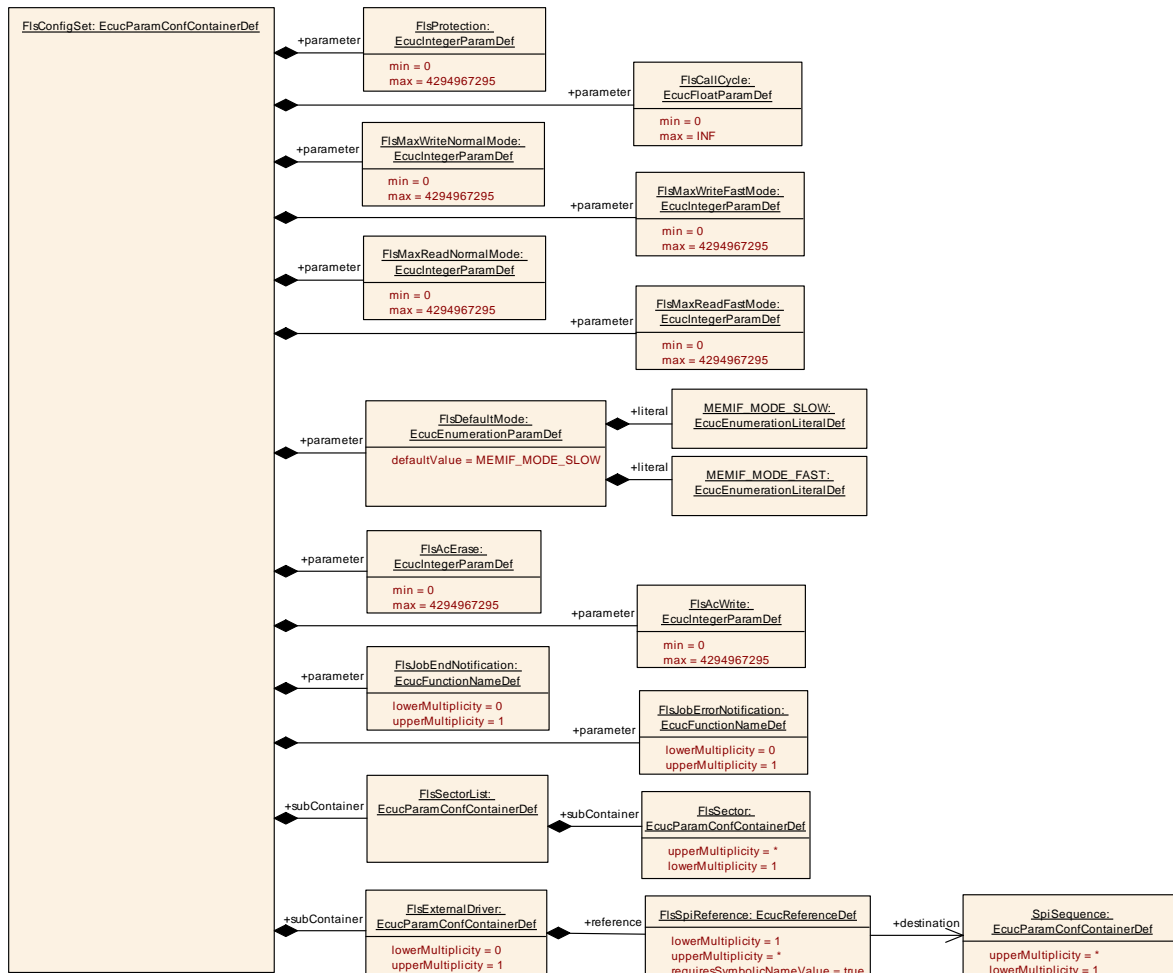

Figure 6: Runtime Configuration Parameters

### 10.1.4 FlsExternalDriver

<b>SWS Item</b>	<b>ECUC_Fls_00316 :</b>
<b>Container Name</b>	FlsExternalDriver
<b>Parent Container</b>	FlsConfigSet
<b>Description</b>	This container is present for external Flash drivers only. Internal Flash drivers do not use the parameter listed in this container, hence its multiplicity is 0 for internal drivers.
<b>Configuration Parameters</b>	

<b>SWS Item</b>	<b>ECUC_Fls_00317 :</b>
<b>Name</b>	FlsSpiReference

<b>Parent Container</b>	FlsExternalDriver		
<b>Description</b>	Reference to SPI sequence (required for external Flash drivers).		
<b>Multiplicity</b>	1..*		
<b>Type</b>	Symbolic name reference to [ SpiSequence ]		
<b>Post-Build Multiplicity</b>	<b>Variant</b>	false	
<b>Post-Build Variant Value</b>	false		
<b>Multiplicity Configuration Class</b>	<b>Pre-compile time</b>	X	All Variants
	<b>Link time</b>	--	
	<b>Post-build time</b>	--	
<b>Value Configuration Class</b>	<b>Pre-compile time</b>	X	All Variants
	<b>Link time</b>	--	
	<b>Post-build time</b>	--	
<b>Scope / Dependency</b>	scope: local		

**No Included Containers**

### 10.1.5 FlsSectorList

<b>SWS Item</b>	<b>ECUC_Fls_00201 :</b>		
<b>Container Name</b>	FlsSectorList		
<b>Parent Container</b>	FlsConfigSet		
<b>Description</b>	List of flashable sectors and pages.		
<b>Configuration Parameters</b>			

#### Included Containers

<b>Container Name</b>	<b>Multiplicity</b>	<b>Scope / Dependency</b>
FlsSector	1..*	Configuration description of a flashable sector

### 10.1.6 FlsSector

<b>SWS Item</b>	<b>ECUC_Fls_00202 :</b>		
<b>Container Name</b>	FlsSector		
<b>Parent Container</b>	FlsSectorList		
<b>Description</b>	Configuration description of a flashable sector		
<b>Configuration Parameters</b>			

<b>SWS Item</b>	<b>ECUC_Fls_00280 :</b>		
<b>Name</b>	FlsNumberOfSectors		
<b>Parent Container</b>	FlsSector		
<b>Description</b>	Number of continuous sectors with identical values for FlsSectorSize and FlsPageSize. The parameter FlsSectorStartAddress denotes the start address of the first sector.		
<b>Multiplicity</b>	1		
<b>Type</b>	EcucIntegerParamDef		
<b>Range</b>	0 .. 65535		
<b>Default value</b>	--		
<b>Post-Build Variant Value</b>	false		
<b>Value Configuration Class</b>	<b>Pre-compile time</b>	X	All Variants
	<b>Link time</b>	--	
	<b>Post-build time</b>	--	
<b>Scope / Dependency</b>	scope: local		

<b>SWS Item</b>	<b>ECUC_Fls_00281 :</b>		
<b>Name</b>	FlsPageSize		
<b>Parent Container</b>	FlsSector		
<b>Description</b>	Size of one page of this sector. Implementation Type: Fls_LengthType.		
<b>Multiplicity</b>	1		
<b>Type</b>	EcucIntegerParamDef		
<b>Range</b>	0 .. 4294967295		
<b>Default value</b>	--		
<b>Post-Build Variant Value</b>	false		
<b>Value Configuration Class</b>	<b>Pre-compile time</b>	X	All Variants
	<b>Link time</b>	--	
	<b>Post-build time</b>	--	
<b>Scope / Dependency</b>	scope: local dependency: The sector size has to be an integer multiple of the page size.		

<b>SWS Item</b>	<b>ECUC_Fls_00282 :</b>		
<b>Name</b>	FlsSectorSize		
<b>Parent Container</b>	FlsSector		
<b>Description</b>	Size of this sector. Implementation Type: Fls_LengthType.		
<b>Multiplicity</b>	1		
<b>Type</b>	EcucIntegerParamDef		
<b>Range</b>	0 .. 4294967295		
<b>Default value</b>	--		
<b>Post-Build Variant Value</b>	false		
<b>Value Configuration Class</b>	<b>Pre-compile time</b>	X	All Variants
	<b>Link time</b>	--	
	<b>Post-build time</b>	--	
<b>Scope / Dependency</b>	scope: local dependency: The sector size has to be an integer multiple of the page size.		

<b>SWS Item</b>	<b>ECUC_Fls_00283 :</b>		
<b>Name</b>	FlsSectorStartaddress		
<b>Parent Container</b>	FlsSector		
<b>Description</b>	Start address of this sector. Implementation Type: Fls_AddressType.		
<b>Multiplicity</b>	1		
<b>Type</b>	EcucIntegerParamDef		
<b>Range</b>	0 .. 4294967295		
<b>Default value</b>	--		
<b>Post-Build Variant Value</b>	false		
<b>Value Configuration Class</b>	<b>Pre-compile time</b>	X	All Variants
	<b>Link time</b>	--	
	<b>Post-build time</b>	--	
<b>Scope / Dependency</b>	scope: local		

**No Included Containers**

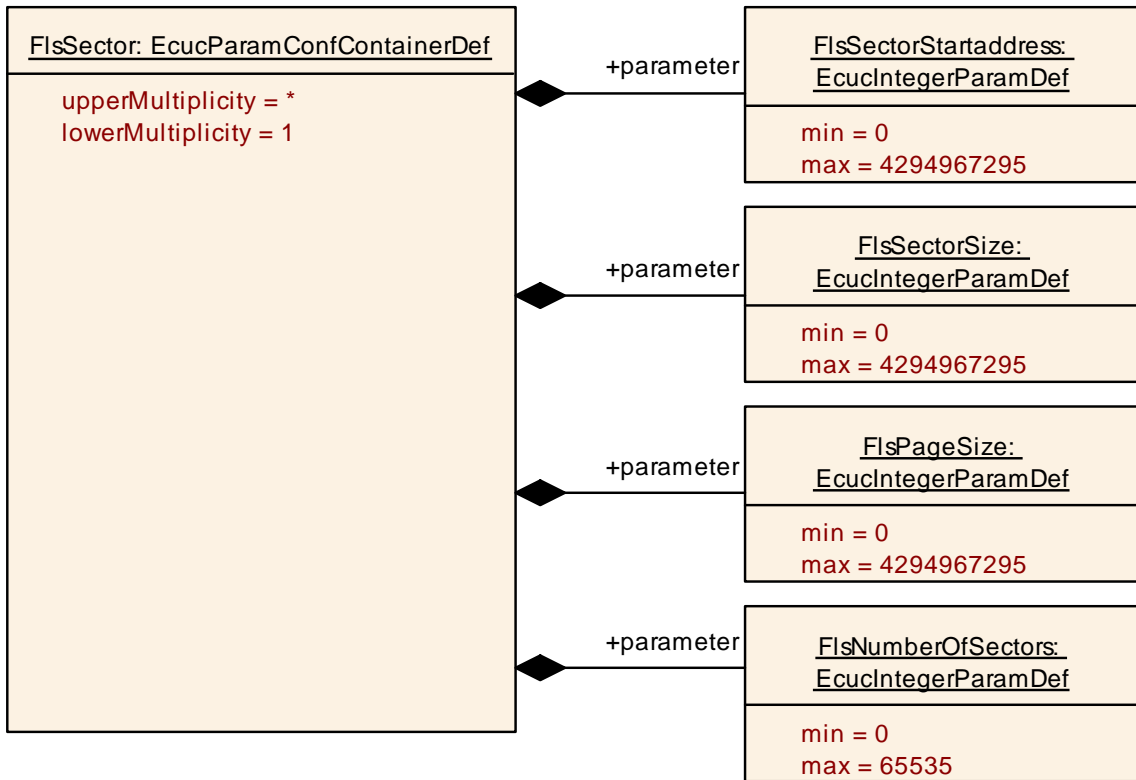

Figure 7: Sector Parameters

## 10.2 Published Information

### 10.2.1 FlsPublishedInformation

<b>SWS Item</b>	<b>ECUC_Fls_00178 :</b>
<b>Container Name</b>	FlsPublishedInformation
<b>Parent Container</b>	Fls
<b>Description</b>	<p>Additional published parameters not covered by CommonPublishedInformation container.</p> <p>Note that these parameters do not have any configuration class setting, since they are published information.</p>
<b>Configuration Parameters</b>	

<b>SWS Item</b>	<b>ECUC_Fls_00294 :</b>
<b>Name</b>	FlsAcLocationErase
<b>Parent Container</b>	FlsPublishedInformation
<b>Description</b>	<p>Position in RAM, to which the erase flash access code has to be loaded. Only relevant if the erase flash access code is not position independent. If this information is not provided it is assumed that the erase flash access code is position independent and that therefore the RAM position can be freely configured.</p>
<b>Multiplicity</b>	1
<b>Type</b>	EcucIntegerParamDef
<b>Range</b>	0 .. 4294967295
<b>Default value</b>	--
<b>Post-Build Variant Value</b>	false
<b>Value Configuration Class</b>	<b>Published Information</b>   X   All Variants
<b>Scope / Dependency</b>	scope: local

<b>SWS Item</b>	<b>ECUC_Fls_00295 :</b>
<b>Name</b>	FlsAcLocationWrite
<b>Parent Container</b>	FlsPublishedInformation
<b>Description</b>	<p>Position in RAM, to which the write flash access code has to be loaded. Only relevant if the write flash access code is not position independent. If this information is not provided it is assumed that the write flash access code is position independent and that therefore the RAM position can be freely configured.</p>
<b>Multiplicity</b>	1
<b>Type</b>	EcucIntegerParamDef
<b>Range</b>	0 .. 4294967295
<b>Default value</b>	--
<b>Post-Build Variant Value</b>	false
<b>Value Configuration Class</b>	<b>Published Information</b>   X   All Variants
<b>Scope / Dependency</b>	scope: local

<b>SWS Item</b>	<b>ECUC_Fls_00296 :</b>
<b>Name</b>	FlsAcSizeErase
<b>Parent Container</b>	FlsPublishedInformation
<b>Description</b>	Number of bytes in RAM needed for the erase flash access code.
<b>Multiplicity</b>	1

<b>Type</b>	EcucIntegerParamDef		
<b>Range</b>	0 .. 4294967295		
<b>Default value</b>	--		
<b>Post-Build Variant Value</b>	false		
<b>Value Configuration Class</b>	<b>Published Information</b>	X	All Variants
<b>Scope / Dependency</b>	scope: local		

<b>SWS Item</b>	<b>ECUC_FIs_00297 :</b>		
<b>Name</b>	FIsAcSizeWrite		
<b>Parent Container</b>	FIsPublishedInformation		
<b>Description</b>	Number of bytes in RAM needed for the write flash access code.		
<b>Multiplicity</b>	1		
<b>Type</b>	EcucIntegerParamDef		
<b>Range</b>	0 .. 4294967295		
<b>Default value</b>	--		
<b>Post-Build Variant Value</b>	false		
<b>Value Configuration Class</b>	<b>Published Information</b>	X	All Variants
<b>Scope / Dependency</b>	scope: local		

<b>SWS Item</b>	<b>ECUC_FIs_00299 :</b>		
<b>Name</b>	FIsErasedValue		
<b>Parent Container</b>	FIsPublishedInformation		
<b>Description</b>	The contents of an erased flash memory cell.		
<b>Multiplicity</b>	1		
<b>Type</b>	EcucIntegerParamDef		
<b>Range</b>	0 .. 4294967295		
<b>Default value</b>	--		
<b>Post-Build Variant Value</b>	false		
<b>Value Configuration Class</b>	<b>Published Information</b>	X	All Variants
<b>Scope / Dependency</b>	scope: local		

<b>SWS Item</b>	<b>ECUC_FIs_00298 :</b>		
<b>Name</b>	FIsEraseTime		
<b>Parent Container</b>	FIsPublishedInformation		
<b>Description</b>	Maximum time to erase one complete flash sector.		
<b>Multiplicity</b>	1		
<b>Type</b>	EcucFloatParamDef		
<b>Range</b>	[0 .. INF]		
<b>Default value</b>	--		
<b>Post-Build Variant Value</b>	false		
<b>Value Configuration Class</b>	<b>Published Information</b>	X	All Variants
<b>Scope / Dependency</b>	scope: local		

<b>SWS Item</b>	<b>ECUC_FIs_00300 :</b>		
<b>Name</b>	FIsExpectedHwld		
<b>Parent Container</b>	FIsPublishedInformation		
<b>Description</b>	Unique identifier of the hardware device that is expected by this driver (the device for which this driver has been implemented). Only relevant for external flash drivers.		
<b>Multiplicity</b>	1		
<b>Type</b>	EcucStringParamDef		
<b>Default value</b>	--		
<b>maxLength</b>	--		
<b>minLength</b>	--		
<b>regularExpression</b>	--		
<b>Post-Build Variant Value</b>	false		

<b>Value Configuration Class</b>	<b>Published Information</b>	X	All Variants
<b>Scope / Dependency</b>	scope: local		

<b>SWS Item</b>	<b>ECUC_FIs_00198 :</b>		
<b>Name</b>	FIsSpecifiedEraseCycles		
<b>Parent Container</b>	FIsPublishedInformation		
<b>Description</b>	<p>Number of erase cycles specified for the flash device (usually given in the device data sheet).</p> <p>If the number of specified erase cycles depends on the operating environment (temperature, voltage, ...) during reprogramming of the flash device, the minimum number for which a data retention of at least 15 years over the temperature range from -40Â°C .. +125Â°C can be guaranteed shall be given.</p> <p>Note: If there are different numbers of specified erase cycles for different flash sectors of the device this parameter has to be extended to a parameter list (similar to the sector list above).</p>		
<b>Multiplicity</b>	1		
<b>Type</b>	EcucIntegerParamDef		
<b>Range</b>	0 .. 4294967295		
<b>Default value</b>	--		
<b>Post-Build Variant Value</b>	false		
<b>Value Configuration Class</b>	<b>Published Information</b>	X	All Variants
<b>Scope / Dependency</b>	scope: local		

<b>SWS Item</b>	<b>ECUC_FIs_00301 :</b>		
<b>Name</b>	FIsWriteTime		
<b>Parent Container</b>	FIsPublishedInformation		
<b>Description</b>	Maximum time to program one complete flash page.		
<b>Multiplicity</b>	1		
<b>Type</b>	EcucFloatParamDef		
<b>Range</b>	[0 .. INF]		
<b>Default value</b>	--		
<b>Post-Build Variant Value</b>	false		
<b>Value Configuration Class</b>	<b>Published Information</b>	X	All Variants
<b>Scope / Dependency</b>	scope: local		

**No Included Containers**



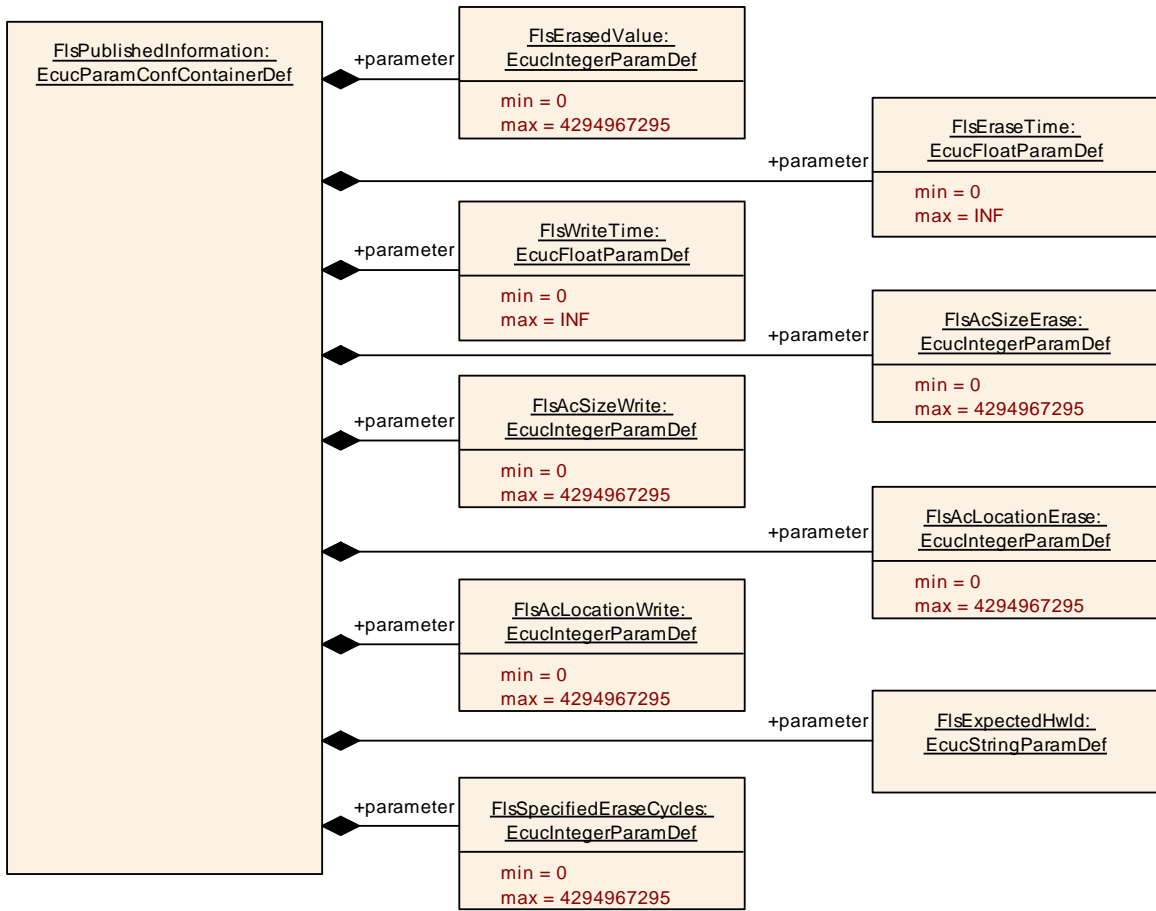

**Figure 8: Additional Published Parameters**

## 11 Not applicable requirements

**[SWS\_Fls\_00366]** [These requirements are not applicable to this specification.]  
(SRS\_BSW\_00344, SRS\_BSW\_00170, SRS\_BSW\_00398, SRS\_BSW\_00375, SRS\_BSW\_00416,  
SRS\_BSW\_00168, SRS\_BSW\_00423, SRS\_BSW\_00424, SRS\_BSW\_00426, SRS\_BSW\_00427,  
SRS\_BSW\_00428, SRS\_BSW\_00429, SRS\_BSW\_00433, SRS\_BSW\_00336, SRS\_BSW\_00339,  
SRS\_BSW\_00422, SRS\_BSW\_00417, SRS\_BSW\_00161, SRS\_BSW\_00162, SRS\_BSW\_00005,  
SRS\_BSW\_00415, SRS\_BSW\_00342, SRS\_BSW\_00160, SRS\_BSW\_00007, SRS\_BSW\_00300,  
SRS\_BSW\_00347, SRS\_BSW\_00307, SRS\_BSW\_00314, SRS\_BSW\_00348, SRS\_BSW\_00353,  
SRS\_BSW\_00361, SRS\_BSW\_00302, SRS\_BSW\_00328, SRS\_BSW\_00312, SRS\_BSW\_00006,  
SRS\_BSW\_00304, SRS\_BSW\_00378, SRS\_BSW\_00306, SRS\_BSW\_00308, SRS\_BSW\_00309,  
SRS\_BSW\_00371, SRS\_BSW\_00359, SRS\_BSW\_00360, SRS\_BSW\_00330, SRS\_BSW\_00009,  
SRS\_BSW\_00401, SRS\_BSW\_00172, SRS\_BSW\_00010, SRS\_BSW\_00333, SRS\_BSW\_00321,  
SRS\_BSW\_00341, SRS\_BSW\_00334, SRS\_SPAL\_12267, SRS\_SPAL\_12163, SRS\_SPAL\_12462,  
SRS\_SPAL\_12463, SRS\_SPAL\_12069, SRS\_SPAL\_12063, SRS\_SPAL\_12064, SRS\_SPAL\_12067,  
SRS\_SPAL\_12078, SRS\_Fls\_12149)