

Document Title	Specification of Communication
Document Owner	AUTOSAR
Document Responsibility	AUTOSAR
Document Identification No	015
Document Status	Final
Part of AUTOSAR Standard	Classic Platform
Part of Standard Release	4.4.0

Document Change History			
Date	Release	Changed by	Change Description
2018-10-31	4.4.0	AUTOSAR Release Management	<ul style="list-style-type: none"> minor corrections / clarifications / editorial changes; For details please refer to the ChangeDocumentation
2017-12-08	4.3.1	AUTOSAR Release Management	<ul style="list-style-type: none"> reverted I-PDU group control APIs to AUTOSAR Release 3 style minor corrections / clarifications / editorial changes; For details please refer to the ChangeDocumentation
2016-11-30	4.3.0	AUTOSAR Release Management	<ul style="list-style-type: none"> updated TX-confirmation handling revised Signal Based Gateway Com-Stack API harmonization minor corrections / clarifications / editorial changes; For details please refer to the ChangeDocumentation
2015-07-31	4.2.2	AUTOSAR Release Management	<ul style="list-style-type: none"> minor corrections / clarifications / editorial changes; For details please refer to the ChangeDocumentation
2014-10-31	4.2.1	AUTOSAR Release Management	<ul style="list-style-type: none"> added support for Sender/ Receiver Serialization updated to support CAN FD minor corrections
2014-03-31	4.1.3	AUTOSAR Release Management	<ul style="list-style-type: none"> Several correction, clarifications and editorial changes No major functional changes or improvements

Document Change History			
Date	Release	Changed by	Change Description
2013-10-31	4.1.2	AUTOSAR Release Management	<ul style="list-style-type: none"> Removed TP-restriction for dynamic length I-PDUs Added parameter to globally enable or disable the cancellation support Many bug fixes, clarifications and harmonization with the other COM-Stack modules Editorial changes Removed chapter(s) on change documentation
2013-03-15	4.1.1	AUTOSAR Administration	<ul style="list-style-type: none"> Reworked according to the new SWS BSW General added support for postbuild loadable configuration harmonization of COM-Stack APIs (TP-APIs & callouts) many corrections and clarifications
2011-12-22	4.0.3	AUTOSAR Administration	<ul style="list-style-type: none"> Several minor changes and bug-fixes Clarification and minor extensions of transmission mode usage and activation Clarification and extension of transfer properties Added retry mechanism for failed transmission requests
2010-09-30	3.1.5	AUTOSAR Administration	<ul style="list-style-type: none"> corrections / clarifications / editorial changes; For details please refer to the ChangeDocumentation
2010-02-02	3.1.4	AUTOSAR Administration	<ul style="list-style-type: none"> Added support for large data types Added support for communication protection Revised mode management interface Many clarifications and corrections based on SWS improvement, validation and conformance test activities Legal disclaimer revised

Document Change History			
Date	Release	Changed by	Change Description
2008-08-13	3.1.1	AUTOSAR Administration	<ul style="list-style-type: none"> Legal disclaimer revised
2008-02-01	3.0.2	AUTOSAR Administration	<ul style="list-style-type: none"> Removed Figure 19, which was included twice
2007-12-21	3.0.1	AUTOSAR Administration	<ul style="list-style-type: none"> Removal of Internal Communication feature Revision of AUTOSAR COM MODULE configuration Revision of Signal Gateway configuration Enhanced maximal I-PDU length for FlexRay Harmonization of callback-interface to RTE Clarifications and bug fixes Document meta information extended Small layout adaptations made
2007-01-24	2.1.15	AUTOSAR Administration	<ul style="list-style-type: none"> Clarifications of requirements throughout the whole document. Chapter 11 contains a detailed list of the made modifications. No new major features were added since release 2.0. “Advice for users” revised “Revision Information” added Legal disclaimer revised
2006-05-16	2.0	AUTOSAR Administration	<ul style="list-style-type: none"> Document structure adapted to common Release 2.0 SWS Template. Integration of signal gateway Major updates in configuration, error handling, filtering, transmission mode switches, callouts, update-bits, deadline monitoring and initialization
2005-05-31	1.0	AUTOSAR Administration	<ul style="list-style-type: none"> Initial release

Disclaimer

This work (specification and/or software implementation) and the material contained in it, as released by AUTOSAR, is for the purpose of information only. AUTOSAR and the companies that have contributed to it shall not be liable for any use of the work.

The material contained in this work is protected by copyright and other types of intellectual property rights. The commercial exploitation of the material contained in this work requires a license to such intellectual property rights.

This work may be utilized or reproduced without any modification, in any form or by any means, for informational purposes only. For any other purpose, no part of the work may be utilized or reproduced, in any form or by any means, without permission in writing from the publisher.

The work has been developed for automotive applications only. It has neither been developed, nor tested for non-automotive applications.

The word AUTOSAR and the AUTOSAR logo are registered trademarks.

Table of Contents

1	Introduction and Functional Overview	9
2	Acronyms, Abbreviations and Definitions	10
2.1	Acronyms and Abbreviations	10
2.2	Definitions.....	10
3	Related Documentation	12
3.1	Deliverables of AUTOSAR	12
3.2	Related Standards and Norms	13
3.3	Related Specification.....	13
4	Constraints and Assumptions.....	14
4.1	Limitations	14
4.2	Applicability to Car Domains.....	14
5	Dependencies to Other Modules	15
5.1	PDU Router	15
5.2	Runtime Environment (RTE)	16
6	Requirements Traceability.....	17
7	Functional Specification.....	27
7.1	Introduction.....	27
7.2	General Functionality.....	27
7.2.1	AUTOSAR COM basis	27
7.2.2	Signal Values	28
7.2.3	Endianness Conversion and Sign Extension	29
7.2.4	Filtering	31
7.2.5	Signal Gateway	33
7.3	Normal Operation	34
7.3.1	Start-Up Behavior.....	34
7.3.2	De-Initialization.....	35
7.3.3	Communication Modes	35
7.3.4	Signal Invalidation	44
7.3.5	Handling of I-PDUs	46
7.3.6	Deadline Monitoring	52
7.3.7	Notification handling.....	57
7.4	Signal Groups - Complex Data Types	58
7.4.1	Initialization	58
7.4.2	Transmission.....	58
7.4.3	Reception	59
7.4.4	Notifications.....	59
7.4.5	Attributes of a Signal Group.....	60
7.4.6	UINT8-array based access to signal groups	60
7.5	Large Data Types	62
7.5.1	Transmission of Large Signals/ I-PDUs	63
7.5.2	Reception of Large Signals/ I-PDUs.....	64
7.6	Dynamic Length Signals.....	64
7.6.1	Transmission of Dynamic Length Signals/ I-PDUs.....	65
7.6.2	Reception of Dynamic Length Signals/ I-PDUs	66

7.7	Interface between AUTOSAR COM Module and the PDU Router	66
7.8	Update-Bits.....	67
7.8.1	Sender Side	67
7.8.2	Receiver Side.....	68
7.9	Data Sequence Control	69
7.9.1	Sender Side	69
7.9.2	Receiver Side.....	69
7.10	Communication Protection	70
7.10.1	Sender Side	71
7.10.2	Receiver Side.....	71
7.10.3	Constraints.....	71
7.11	Signal Gateway	72
7.11.1	Dealing with Signals.....	73
7.11.2	Dealing with Group Signals.....	73
7.11.3	Routing of Out-Timed Signals and Signal Groups.....	74
7.11.4	Handling of Update-Bits	74
7.11.5	Decoupling Signal Gateway	75
7.12	Error Classification	75
7.12.1	Development Errors	75
7.12.2	Runtime Errors	76
7.12.3	Transient Faults	76
7.12.4	Production Errors	76
7.12.5	Extended Production Errors	76
7.13	Error Notification.....	76
7.14	Error Handling	76
7.15	AUTOSAR COM Module's Interaction Model	77
8	API Specification	81
8.1	Imported Types	81
8.2	Type Definitions.....	81
8.2.1	Com_StatusType	81
8.2.2	Com_SignalIdType.....	81
8.2.3	Com_SignalGroupIdType.....	81
8.2.4	Com_IpduGroupIdType.....	82
8.2.5	Com_ConfigType	82
8.3	Function Definitions	82
8.3.1	Return Codes	82
8.3.2	Start-Up and Control Services.....	83
8.3.3	Communication Services	87
8.4	Callback Functions and Notifications.....	96
8.4.1	Com_TriggerTransmit	96
8.4.2	Com_RxIndication.....	98
8.4.3	Com_TpRxIndication.....	98
8.4.4	Com_TxConfirmation	98
8.4.5	Com_TpTxConfirmation	99
8.4.6	Com_StartOfReception	99
8.4.7	Com_CopyRxData	101
8.4.8	Com_CopyTxData.....	101
8.5	Scheduled Functions	103
8.5.1	Com_MainFunctionRx.....	103

8.5.2	Com_MainFunctionTx	103
8.5.3	Com_MainFunctionRouteSignals	104
8.6	Expected Interfaces	104
8.6.1	Mandatory Interfaces	104
8.6.2	Optional Interfaces	104
8.6.3	Configurable Interfaces	105
9	Sequence Diagrams	111
9.1	Interface between the AUTOSAR COM Module and the PDU Router.....	111
9.2	Confirmation Handling between the PDU Router, the AUTOSAR COM Module and the RTE.....	113
9.3	Indication Handling between the PDU Router, the AUTOSAR COM Module and the RTE.....	114
10	Configuration Specification	115
10.1	Containers and Configuration Parameters	115
10.1.1	Configuration of the AUTOSAR COM Module.....	116
10.1.2	Com	117
10.1.3	ComGeneral.....	117
10.1.4	ComConfig	120
10.1.5	ComTimeBase	121
10.1.6	ComFilter.....	123
10.1.7	ComIPdu	126
10.1.8	ComIPduCounter	131
10.1.9	ComIPduReplication	132
10.1.10	ComTxIPdu.....	133
10.1.11	ComIPduGroup.....	135
10.1.12	ComSignal	136
10.1.13	ComSignalGroup	147
10.1.14	ComGroupSignal	154
10.1.15	ComTxMode	160
10.1.16	ComTxModeTrue.....	162
10.1.17	ComTxModeFalse	162
10.1.18	ComGwMapping.....	163
10.1.19	ComGwSource	163
10.1.20	ComGwSourceDescription	164
10.1.21	ComGwDestination.....	167
10.1.22	ComGwDestinationDescription.....	167
10.1.23	ComGwSignal.....	170
10.2	Configuration Rules	171
10.2.1	General Rules	171
10.2.2	Signal Configuration.....	172
10.2.3	Signal Group Configuration	173
10.2.4	Transmission Mode Configuration.....	173
10.2.5	Signal Gateway Configuration.....	173
10.2.6	Filter Configuration.....	174
10.2.7	Post Build Configuration.....	174
10.2.8	Dynamic Length I-PDUs.....	174
10.2.9	Replicated I-PDUs.....	174
10.2.10	I-PDU group.....	175

11	Not Applicable Requirements	176
12	Appendix A	177

1 Introduction and Functional Overview

This specification is the AUTOSAR COM module Software Specification. It is based on the AUTOSAR COM SRS [7]. It specifies how the requirements of the AUTOSAR COM SRS shall be realized. That means that the functionality and the API of the AUTOSAR COM module are described in this document.

Within the AUTOSAR Layered Architecture the AUTOSAR COM module is placed between RTE and the PDU Router, see [1].

The AUTOSAR COM module is derived from [17]. For details, see Chapter 7.2.1. The AUTOSAR COM module provides signal gateway functionality. For details, see Chapter 7.2.5.

Main Features:

- Provision of signal oriented data interface for the RTE
- Packing of AUTOSAR signals to I-PDUs to be transmitted
- Unpacking of received I-PDUs and provision of received signals to RTE
- Routing of signals from received I-PDUs into I-PDUs to become transmitted
- Routing of signal groups from received I-PDUs into I-PDUs to become transmitted
- Communication transmission control (start/ stop of I-PDU groups)
- Replications of send requests
- Guarantee of minimum distances between transmit I-PDUs
- Monitoring of receive signals (signals timeout)
- Filter mechanisms for incoming signals
- Different notification mechanisms
- Provision of init values and update indications
- Byte order conversion
- Sign extension
- Support of two different transmission modes per I-PDU
- Signal based gateway
- Support of large and dynamic length data types
- Support of I-PDU counters and I-PDU replication

2 Acronyms, Abbreviations and Definitions

2.1 Acronyms and Abbreviations

Acronym:	Description:
AUTOSAR COM	The AUTOSAR COM module is derived from [17]. For details, see Chapter 7.2.1.
DM	Deadline Monitoring, for details see Chapter 7.3.6
I-PDU	Interaction Layer Protocol Data Unit An I-PDU carries signals. It is defined in [17].
L-PDU	Data Link Layer Protocol Data Unit. In AUTOSAR, the Data Link Layer is equivalent to the Communication Hardware Abstraction and Microcontroller Abstraction Layer.
MDT	A detailed description of the Minimum Delay Timer (MDT) can be found in [17]. See also Chapter 7.3.5.5.
PDU Router	The PDU Router is a module transferring I-PDUs from one module to another module. The PDU Router can be utilized for gateway operations and for internal routing purposes.
SDU	Service Data Unit For a description see [1] Chapter 4.
TM	Transmission Mode
TMC	Transmission Mode Condition, see Chapter 7.3.3.2
TMS	Transmission Mode Selector, see Chapter 7.3.3.2

2.2 Definitions

Term:	Description:
Confirmation	With a Confirmation, the PDU Router reports that a request by the AUTOSAR COM module has been completed successfully. It is a reaction to a request of COM. E.g. when a PDU has been successfully transmitted.
Data Invalid Value	Value sent by the AUTOSAR COM module to indicate that the sender side AUTOSAR Software Component is not able to provide a valid value.
Dynamic Length Signal	A dynamic length signal is a signal which length can vary at run-time.
Dynamic Length I-PDU	A dynamic length I-PDU is an I-PDU containing a dynamic length signal. Its length varies depending on the length of the included dynamic length signal.
Group signal	A group signal is a signal that is contained in a signal group.
Indication	An Indication is asynchronous information from PDU Router to COM, e.g. to acknowledge that something has been received.
Init Value	I-PDUs and signals are set to the Init Value by the AUTOSAR COM module after start-up. This value is used until it is overwritten.
I-PDU group	An I-PDU Group is an arbitrary collection of I-PDUs of the same direction (i.e. send or receive) in the COM module.
Inter-ECU – communication	Communication between two or more ECUs for example via a CAN network
Intra-ECU – communication	Communication between Software components that reside on the same ECU
Large Signal	A large signal is a signal that is too large to fit into a single L-PDU of the underlying communication protocol.
Large I-PDU	Large I-PDUs are I-Signal-I-PDUs which do not fit into a single L-PDU of the underlying communication protocol. Large I-PDUs will be handled like other

Term:	Description:
	<p>I-PDUs by COM, but are transmitted/received via the TP API. Please note that large I-PDUs can also be handled in a more efficient way by LargeDataCOM if they contain just one signal, or if the signals can be (de-)serialized by the RTE. But if the signals have to be treated separately or have to be routed, the large I-PDUs have to be handled by COM.</p>
Message	<p>[17] uses always the synonym <i>message</i>. In AUTOSAR, <i>message</i> is replaced by <i>signal</i> but with the same meaning.</p>
Metadata	<p>For some I-PDUs, e.g. J1939 I-PDUs, the payload is extended with additional metadata containing for example the CAN-ID.</p>
Notification	<p>Information by the AUTOSAR COM module to RTE, e.g. when new data is available, an error occurred.</p>
Signal	<p>A signal in the AUTOSAR COM module's context is equal to a message in [17]; see also [7].</p>
Signal group	<p>In AUTOSAR, so called complex data types are used. Inside a complex data type, there are one or more data elements (primitive data types), like in a C struct. The data consistency of such complex data types must be ensured.</p> <p>The RTE decomposes the complex data type in single signals and sends them to the AUTOSAR COM module. As these signals altogether need to be treated consistently, they are called <i>signal group</i>.</p> <p>See also [7].</p>
Update-bit	<p>A mechanism supported by the AUTOSAR COM module with that the receiver of a signal/ signal group could identify whether the sender has updated the data in this signal/ signal group before sending. See Chapter 7.8.</p>

3 Related Documentation

3.1 Deliverables of AUTOSAR

- [1] AUTOSAR Layered Architecture
AUTOSAR_EXP_LayeredSoftwareArchitecture.pdf
- [2] Specification of Communication Stack Types
AUTOSAR_SWS_CommunicationStackTypes.pdf
- [3] General Requirements on Basic Software Modules
AUTOSAR_SRS_BSWGeneral.pdf
- [4] Basic Software UML Model
AUTOSAR_MOD_BSWUMLModel.eap
- [5] Specification of Standard Types
AUTOSAR_SWS_StandardTypes.pdf
- [6] Specification of the Virtual Functional Bus
AUTOSAR_EXP_VFB.pdf
- [7] Requirements on Communication
AUTOSAR_SRS_COM.pdf
- [8] Software Component Template
AUTOSAR_TPS_SoftwareComponentTemplate.pdf
- [9] Requirements on Gateway
AUTOSAR_SRS_Gateway.pdf
- [10] Specification of PDU Router
AUTOSAR_SWS_PDURouter.pdf
- [11] Specification of Operating System
AUTOSAR_SWS_OS.pdf
- [12] System Template
AUTOSAR_TPS_SystemTemplate.pdf
- [13] Specification of RTE Software
AUTOSAR_SWS_RTE.pdf
- [14] Specification of ECU Configuration
AUTOSAR_TPS_ECUConfiguration.pdf

- [15] Specification of Communication Manager
AUTOSAR_SWS_COMManager.pdf
- [16] AUTOSAR Basic Software Module Description Template
AUTOSAR_TPS_BSWModuleDescriptionTemplate.pdf
- [19] Specification of CAN Transport Layer
AUTOSAR_SWS_CANTransportLayer.pdf
- [20] Specification of FlexRay Transport Layer
AUTOSAR_SWS_FlexRayTransportLayer.pdf
- [21] List of Basic Software Modules,
AUTOSAR_TR_BSWModuleList.pdf
- [22] Generic Structure Template
AUTOSAR_TPS_GenericStructureTemplate.pdf
- [23] General Specification of Basic Software Modules
AUTOSAR_SWS_BSWGeneral.pdf

3.2 Related Standards and Norms

- [17] ISO 17356-4:2005 Road vehicles -- Open interface for embedded automotive applications -- Part 4: OSEK/VDX Communication (COM)
- [18] ISO 17356-6:2006 Road vehicles -- Open interface for embedded automotive applications -- Part 6: OSEK/VDX Implementation Language (OIL)

3.3 Related Specification

AUTOSAR provides a General Specification on Basic Software modules [23] (SWS BSW General), which is also valid for COM.

Thus, the specification SWS BSW General shall be considered as additional and required specification for COM.

4 Constraints and Assumptions

4.1 Limitations

The AUTOSAR COM module is based on [17]. Nevertheless not all features of [17] are included and some features are different. See SWS_Com_00013 for a list of not included features.

4.2 Applicability to Car Domains

No restrictions.

5 Dependencies to Other Modules

This chapter lists all the features from other modules that are used by the AUTOSAR COM module and functionalities that are provided by the AUTOSAR COM module to other modules. For the placement of the AUTOSAR COM module in the communication stack, see **Figure 1**.

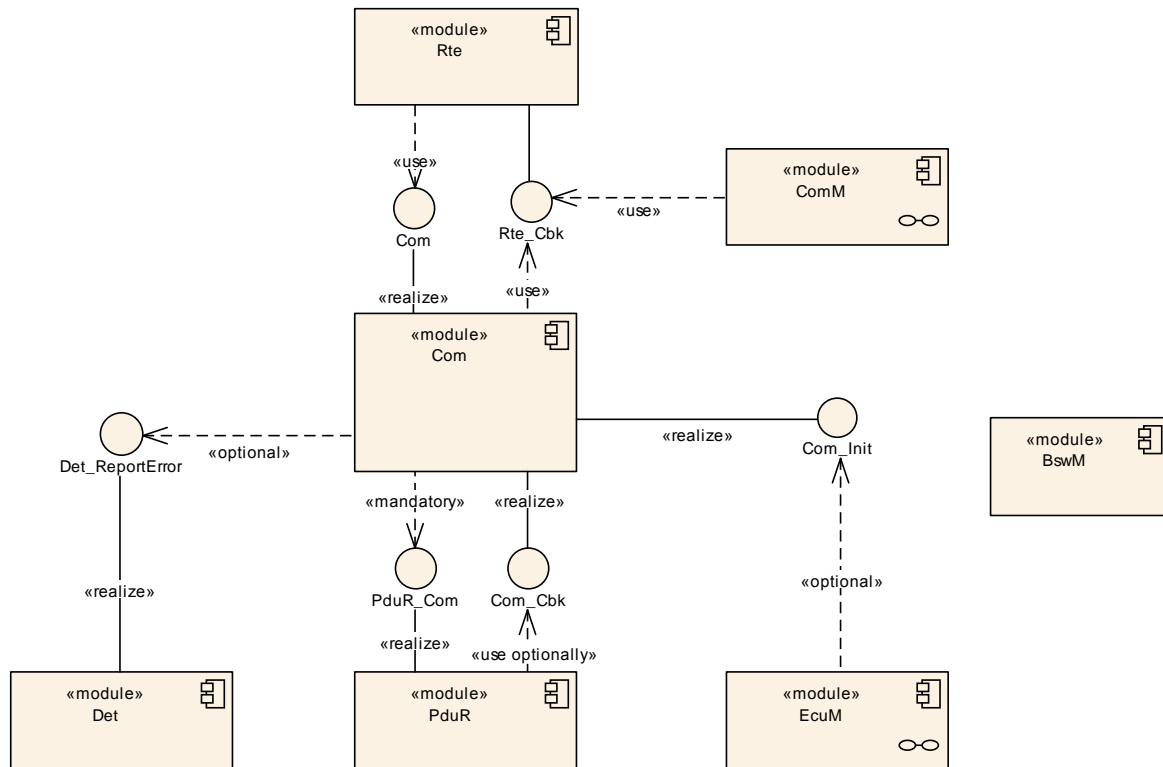

Figure 1: AUTOSAR COM module's context view

5.1 PDU Router

The AUTOSAR COM module uses the union of both sets of PDU Router's upper layer module APIs. That is the APIs for upper layer modules that uses TP and the APIs for upper layer modules that do not use TP. This is necessary since the AUTOSAR COM module transports I-PDUs either unfragmented via simple L-PDUs or fragmented via TP.

The following summarizes the functionality of the AUTOSAR COM module needs from the underlying layer PDU Router:

- Indication of incoming I-PDUs
- Sending interface for outgoing I-PDUs including the confirmation if an I-PDU has been sent by the communication controller
- Trigger interface to enable the PDU router to cause a transmission from the AUTOSAR COM module
- Buffer handling for TP communication

Chapter 7.5 and Chapter 9.1 include a detailed description of the interfaces to the PDU Router. For further information, see [10].

5.2 Runtime Environment (RTE)

The RTE uses the capabilities of the AUTOSAR COM module to send and receive signals. In AUTOSAR, the RTE is the higher layer above the AUTOSAR COM module. For further information, see [13].

6 Requirements Traceability

The following table references the requirements specified in [3], [7], [17] and [9] and links to the fulfillment of these. Requirements that are not fulfilled by this document are linked to SWS_Com_00999.

Requirement	Description	Satisfied by
SRS_BSW_00003	All software modules shall provide version and identification information	SWS_Com_00426
SRS_BSW_00005	Modules of the μ C Abstraction Layer (MCAL) may not have hard coded horizontal interfaces	SWS_Com_00999
SRS_BSW_00006	The source code of software modules above the μ C Abstraction Layer (MCAL) shall not be processor and compiler dependent.	SWS_Com_00999
SRS_BSW_00009	All Basic SW Modules shall be documented according to a common standard.	SWS_Com_00999
SRS_BSW_00010	The memory consumption of all Basic SW Modules shall be documented for a defined configuration for all supported platforms.	SWS_Com_00999
SRS_BSW_00101	The Basic Software Module shall be able to initialize variables and hardware in a separate initialization function	SWS_Com_00015, SWS_Com_00059, SWS_Com_00098, SWS_Com_00117, SWS_Com_00128, SWS_Com_00217, SWS_Com_00328, SWS_Com_00432, SWS_Com_00484, SWS_Com_00850
SRS_BSW_00161	The AUTOSAR Basic Software shall provide a microcontroller abstraction layer which provides a standardized interface to higher software layers	SWS_Com_00999
SRS_BSW_00162	The AUTOSAR Basic Software shall provide a hardware abstraction layer	SWS_Com_00999
SRS_BSW_00164	The Implementation of interrupt service routines shall be done by the Operating System, complex drivers or modules	SWS_Com_00999
SRS_BSW_00167	All AUTOSAR Basic Software Modules shall provide configuration rules and constraints to enable plausibility checks	SWS_Com_00497

SRS_BSW_00168	SW components shall be tested by a function defined in a common API in the Basis-SW	SWS_Com_00999
SRS_BSW_00170	The AUTOSAR SW Components shall provide information about their dependency from faults, signal qualities, driver demands	SWS_Com_00999
SRS_BSW_00171	Optional functionality of a Basic-SW component that is not required in the ECU shall be configurable at pre-compile-time	SWS_Com_00999
SRS_BSW_00301	All AUTOSAR Basic Software Modules shall only import the necessary information	SWS_Com_00609
SRS_BSW_00302	All AUTOSAR Basic Software Modules shall only export information needed by other modules	SWS_Com_00999
SRS_BSW_00306	AUTOSAR Basic Software Modules shall be compiler and platform independent	SWS_Com_00999
SRS_BSW_00307	Global variables naming convention	SWS_Com_00999
SRS_BSW_00308	AUTOSAR Basic Software Modules shall not define global data in their header files, but in the C file	SWS_Com_00999
SRS_BSW_00309	All AUTOSAR Basic Software Modules shall indicate all global data with read-only purposes by explicitly assigning the const keyword	SWS_Com_00999
SRS_BSW_00312	Shared code shall be re-entrant	SWS_Com_00321
SRS_BSW_00314	All internal driver modules shall separate the interrupt frame definition from the service routine	SWS_Com_00999
SRS_BSW_00321	The version numbers of AUTOSAR Basic Software Modules shall be enumerated according specific rules	SWS_Com_00999
SRS_BSW_00325	The runtime of interrupt service routines and functions that are running in interrupt context shall be kept short	SWS_Com_00999
SRS_BSW_00327	Error values naming convention	SWS_Com_00442

SRS_BSW_00328	All AUTOSAR Basic Software Modules shall avoid the duplication of code	SWS_Com_00999
SRS_BSW_00331	All Basic Software Modules shall strictly separate error and status information	SWS_Com_00194
SRS_BSW_00333	For each callback function it shall be specified if it is called from interrupt context or not	SWS_Com_00999
SRS_BSW_00334	All Basic Software Modules shall provide an XML file that contains the meta data	SWS_Com_00999
SRS_BSW_00335	Status values naming convention	SWS_Com_00819
SRS_BSW_00336	Basic SW module shall be able to shutdown	SWS_Com_00129, SWS_Com_00130
SRS_BSW_00337	Classification of development errors	SWS_Com_00803, SWS_Com_00804
SRS_BSW_00341	Module documentation shall contain all needed informations	SWS_Com_00999
SRS_BSW_00344	BSW Modules shall support link-time configuration	SWS_Com_00432
SRS_BSW_00347	A Naming separation of different instances of BSW drivers shall be in place	SWS_Com_00999
SRS_BSW_00348	All AUTOSAR standard types and constants shall be placed and organized in a standard type header file	SWS_Com_00865
SRS_BSW_00353	All integer type definitions of target and compiler specific scope shall be placed and organized in a single type header	SWS_Com_00999
SRS_BSW_00358	The return type of init() functions implemented by AUTOSAR Basic Software Modules shall be void	SWS_Com_00432
SRS_BSW_00359	All AUTOSAR Basic Software Modules callback functions shall avoid return types other than void if possible	SWS_Com_00468, SWS_Com_00491, SWS_Com_00536, SWS_Com_00554, SWS_Com_00555, SWS_Com_00556
SRS_BSW_00360	AUTOSAR Basic Software Modules callback functions are allowed to have parameters	SWS_Com_00468, SWS_Com_00491, SWS_Com_00536, SWS_Com_00554, SWS_Com_00555, SWS_Com_00556
SRS_BSW_00361	All mappings of not standardized keywords of compiler specific scope shall be	SWS_Com_00999

	placed and organized in a compiler specific type and keyword header	
SRS_BSW_00369	All AUTOSAR Basic Software Modules shall not return specific development error codes via the API	SWS_Com_00442
SRS_BSW_00375	Basic Software Modules shall report wake-up reasons	SWS_Com_00999
SRS_BSW_00377	A Basic Software Module can return a module specific types	SWS_Com_00865
SRS_BSW_00378	AUTOSAR shall provide a boolean type	SWS_Com_00999
SRS_BSW_00383	The Basic Software Module specifications shall specify which other configuration files from other modules they use at least in the description	SWS_Com_00999
SRS_BSW_00384	The Basic Software Module specifications shall specify at least in the description which other modules they require	SWS_Com_00669, SWS_Com_00670
SRS_BSW_00385	List possible error notifications	SWS_Com_00442
SRS_BSW_00386	The BSW shall specify the configuration for detecting an error	SWS_Com_00999
SRS_BSW_00404	BSW Modules shall support post-build configuration	SWS_Com_00432, SWS_Com_00825
SRS_BSW_00405	BSW Modules shall support multiple configuration sets	SWS_Com_00432
SRS_BSW_00407	Each BSW module shall provide a function to read out the version information of a dedicated module implementation	SWS_Com_00426
SRS_BSW_00409	All production code error ID symbols are defined by the Dem module and shall be retrieved by the other BSW modules from Dem configuration	SWS_Com_00999
SRS_BSW_00410	Compiler switches shall have defined values	SWS_Com_00999
SRS_BSW_00413	An index-based accessing of the instances of BSW modules shall be done	SWS_Com_00999
SRS_BSW_00414	Init functions shall have a pointer to a configuration structure as single parame-	SWS_Com_00432, SWS_Com_00805, SWS_Com_00837

	ter	
SRS_BSW_00416	The sequence of modules to be initialized shall be configurable	SWS_Com_00999
SRS_BSW_00417	Software which is not part of the SW-C shall report error events only after the DEM is fully operational.	SWS_Com_00999
SRS_BSW_00423	BSW modules with AUTOSAR interfaces shall be describable with the means of the SW-C Template	SWS_Com_00999
SRS_BSW_00424	BSW module main processing functions shall not be allowed to enter a wait state	SWS_Com_00999
SRS_BSW_00425	The BSW module description template shall provide means to model the defined trigger conditions of schedulable objects	SWS_Com_00359, SWS_Com_00398, SWS_Com_00399, SWS_Com_00400, SWS_Com_00664, SWS_Com_00665, SWS_Com_00666
SRS_BSW_00426	BSW Modules shall ensure data consistency of data which is shared between BSW modules	SWS_Com_00999
SRS_BSW_00427	ISR functions shall be defined and documented in the BSW module description template	SWS_Com_00999
SRS_BSW_00428	A BSW module shall state if its main processing function(s) has to be executed in a specific order or sequence	SWS_Com_00999
SRS_BSW_00429	Access to OS is restricted	SWS_Com_00999
SRS_BSW_00432	Modules should have separate main processing functions for read/receive and write/transmit data path	SWS_Com_00359, SWS_Com_00398, SWS_Com_00399, SWS_Com_00400, SWS_Com_00466
SRS_BSW_00433	Main processing functions are only allowed to be called from task bodies provided by the BSW Scheduler	SWS_Com_00999
SRS_BSW_00437	Memory mapping shall provide the possibility to define RAM segments which are not to be initialized during startup	SWS_Com_00999
SRS_BSW_00441	Naming convention for type, macro and function	SWS_Com_00820, SWS_Com_00821, SWS_Com_00822, SWS_Com_00825, SWS_Com_00865
SRS_BSW_00452	Classification of runtime errors	SWS_Com_00864
SRS_Com_00177	AUTOSAR COM and	SWS_Com_00853, SWS_Com_00856

	LargeDataCOM shall support multiple configuration stages	
SRS_Com_00192	The AUTOSAR COM module shall support enabling and disabling reception deadline monitoring of I-PDU groups	SWS_Com_00224, SWS_Com_00225, SWS_Com_00486, SWS_Com_00534, SWS_Com_00772, SWS_Com_91003, SWS_Com_91004
SRS_Com_00218	The AUTOSAR COM module shall support starting and stopping multiple I-PDU groups during runtime	SWS_Com_00114, SWS_Com_00115, SWS_Com_00222, SWS_Com_00223, SWS_Com_00228, SWS_Com_00229, SWS_Com_00334, SWS_Com_00444, SWS_Com_00479, SWS_Com_00684, SWS_Com_00685, SWS_Com_00713, SWS_Com_00714, SWS_Com_00733, SWS_Com_00771, SWS_Com_00777, SWS_Com_00782, SWS_Com_00783, SWS_Com_00787, SWS_Com_00800, SWS_Com_00822, SWS_Com_00840, SWS_Com_00871, SWS_Com_00877, SWS_Com_91001, SWS_Com_91002
SRS_Com_02030	The AUTOSAR COM module shall support to detect if a received signal or signal group was updated by the sender	SWS_Com_00055, SWS_Com_00059, SWS_Com_00061, SWS_Com_00062, SWS_Com_00067, SWS_Com_00117, SWS_Com_00310, SWS_Com_00324, SWS_Com_00577, SWS_Com_00578, SWS_Com_00702, SWS_Com_00703, SWS_Com_00704, SWS_Com_00705, SWS_Com_00706, SWS_Com_00801, SWS_Com_00802
SRS_Com_02037	AUTOSAR COM module shall be based on the functionality and APIs of DOC_ISO_COM	SWS_Com_00010, SWS_Com_00011, SWS_Com_00012, SWS_Com_00013, SWS_Com_00132, SWS_Com_00138, SWS_Com_00197, SWS_Com_00198, SWS_Com_00231, SWS_Com_00273, SWS_Com_00302, SWS_Com_00303, SWS_Com_00304, SWS_Com_00325, SWS_Com_00346, SWS_Com_00348, SWS_Com_00380, SWS_Com_00381, SWS_Com_00388, SWS_Com_00395, SWS_Com_00396, SWS_Com_00439, SWS_Com_00445, SWS_Com_00469, SWS_Com_00471, SWS_Com_00481, SWS_Com_00492, SWS_Com_00603, SWS_Com_00604, SWS_Com_00624, SWS_Com_00625, SWS_Com_00631, SWS_Com_00694, SWS_Com_00695, SWS_Com_00696, SWS_Com_00697, SWS_Com_00698, SWS_Com_00700, SWS_Com_00719, SWS_Com_00762, SWS_Com_00764, SWS_Com_00766, SWS_Com_00773, SWS_Com_00774, SWS_Com_00775, SWS_Com_00776, SWS_Com_00789, SWS_Com_00793, SWS_Com_00812, SWS_Com_00816, SWS_Com_00820, SWS_Com_00828, SWS_Com_00835, SWS_Com_00836, SWS_Com_00858, SWS_Com_00861, SWS_Com_00862, SWS_Com_00866,

		SWS_Com_00867, SWS_Com_00868, SWS_Com_00878, SWS_Com_00879, SWS_Com_00880
SRS_Com_02040	AUTOSAR COM and LargeDataCOM shall be configured by using XML as configuration language	SWS_Com_00006
SRS_Com_02041	The AUTOSAR module shall handle complex data types as a consistent set of data	SWS_Com_00050, SWS_Com_00051, SWS_Com_00200, SWS_Com_00201, SWS_Com_00461, SWS_Com_00513, SWS_Com_00635, SWS_Com_00637, SWS_Com_00638, SWS_Com_00639, SWS_Com_00676, SWS_Com_00677, SWS_Com_00678, SWS_Com_00679, SWS_Com_00821, SWS_Com_00851, SWS_Com_00852, SWS_Com_00854, SWS_Com_00855, SWS_Com_00857, SWS_Com_00882
SRS_Com_02042	The AUTOSAR COM module shall fill unused areas/ bits within an I-PDU with a configurable value	SWS_Com_00015
SRS_Com_02043	AUTOSAR COM and LargeDataCOM shall provide a receive indication function	SWS_Com_00123
SRS_Com_02044	AUTOSAR COM and LargeDataCOM shall provide a transmit confirmation function	SWS_Com_00124
SRS_Com_02045	AUTOSAR COM and LargeDataCOM shall provide a function to request the transmit buffer data for lower layer triggered transmission	SWS_Com_00001, SWS_Com_00475, SWS_Com_00647, SWS_Com_00869
SRS_Com_02046	The AUTOSAR COM module shall support immediate and deferred signal based notification to the RTE	SWS_Com_00300, SWS_Com_00301, SWS_Com_00574, SWS_Com_00575, SWS_Com_00794, SWS_Com_00870, SWS_Com_00883
SRS_Com_02058	The AUTOSAR COM module shall support deadline monitoring for updated signals/signal groups on receiver side	SWS_Com_00117, SWS_Com_00290, SWS_Com_00291, SWS_Com_00292, SWS_Com_00715, SWS_Com_00716
SRS_Com_02067	AUTOSAR COM and LargeDataCOM shall define rules for checking the consistency of configuration data	SWS_Com_00102, SWS_Com_00105, SWS_Com_00310, SWS_Com_00365, SWS_Com_00373, SWS_Com_00384, SWS_Com_00401, SWS_Com_00402, SWS_Com_00443, SWS_Com_00465, SWS_Com_00535, SWS_Com_00553, SWS_Com_00732, SWS_Com_00785, SWS_Com_00790, SWS_Com_00817
SRS_Com_02077	The AUTOSAR COM module shall support invalidation of signals at sender side	SWS_Com_00099, SWS_Com_00203, SWS_Com_00557, SWS_Com_00642, SWS_Com_00643, SWS_Com_00645

SRS_Com_02078	The AUTOSAR COM module shall support endianness conversion	SWS_Com_00007, SWS_Com_00221, SWS_Com_00352, SWS_Com_00472, SWS_Com_00580, SWS_Com_00674, SWS_Com_00675, SWS_Com_00810
SRS_Com_02079	The AUTOSAR COM module shall support an optional notification when receiving invalidated data	SWS_Com_00536, SWS_Com_00680, SWS_Com_00681, SWS_Com_00682, SWS_Com_00717, SWS_Com_00718, SWS_Com_00859, SWS_Com_00860
SRS_Com_02080	The AUTOSAR COM module shall cancel outstanding repetitions in case of a new send request	SWS_Com_00279
SRS_Com_02082	The AUTOSAR COM module shall support defining two different transmission modes for each I-PDU	SWS_Com_00032, SWS_Com_00238, SWS_Com_00239, SWS_Com_00244, SWS_Com_00495, SWS_Com_00582, SWS_Com_00784, SWS_Com_00799, SWS_Com_00881
SRS_Com_02083	The AUTOSAR COM module shall support multiple transmission modes	SWS_Com_00135, SWS_Com_00305, SWS_Com_00308, SWS_Com_00330, SWS_Com_00392, SWS_Com_00467, SWS_Com_00478, SWS_Com_00494, SWS_Com_00602, SWS_Com_00734, SWS_Com_00739, SWS_Com_00741, SWS_Com_00742, SWS_Com_00743, SWS_Com_00767, SWS_Com_00768, SWS_Com_00769, SWS_Com_00770
SRS_Com_02084	The AUTOSAR COM module shall support a configurable signal data based selection mechanism of the two transmission modes	SWS_Com_00032, SWS_Com_00245, SWS_Com_00605, SWS_Com_00677, SWS_Com_00678, SWS_Com_00679, SWS_Com_00763, SWS_Com_00799, SWS_Com_00813
SRS_Com_02086	The AUTOSAR COM module shall support sign-extension	SWS_Com_00008, SWS_Com_00352, SWS_Com_00579, SWS_Com_00723, SWS_Com_00829
SRS_Com_02087	The AUTOSAR COM module shall support an optional substitution of received invalidated data	SWS_Com_00470, SWS_Com_00500, SWS_Com_00681, SWS_Com_00683, SWS_Com_00859, SWS_Com_00860
SRS_Com_02088	The AUTOSAR COM module shall support substituting the last received value by the init value in case of a signal timeout	SWS_Com_00470, SWS_Com_00875, SWS_Com_00876
SRS_Com_02089	The AUTOSAR COM module shall provide two configurable options to handle signal timeouts	SWS_Com_00290, SWS_Com_00291, SWS_Com_00292, SWS_Com_00333, SWS_Com_00738, SWS_Com_00744
SRS_Com_02091	AUTOSAR COM and LargeDataCOM shall not support splitting of large signals into different I-PDUs	SWS_Com_00754, SWS_Com_00755, SWS_Com_00756
SRS_Com_02092	The AUTOSAR COM module shall support at most one dynamic length signal per I-	SWS_Com_00690, SWS_Com_00711, SWS_Com_00712, SWS_Com_00724, SWS_Com_00754

	PDU	
SRS_Com_02093	Dynamic length signal must be placed last in I-PDU	SWS_Com_00755, SWS_Com_00757, SWS_Com_00758, SWS_Com_00832
SRS_Com_02094	Dynamic length signals must be of type UINT8n	SWS_Com_00675, SWS_Com_00753
SRS_Com_02095	AUTOSAR COM and LargeDataCOM shall use the TP to fragment and reassemble large signals	SWS_Com_00627, SWS_Com_00628, SWS_Com_00629, SWS_Com_00630, SWS_Com_00650, SWS_Com_00654, SWS_Com_00655, SWS_Com_00657, SWS_Com_00662, SWS_Com_00690, SWS_Com_00691, SWS_Com_00692, SWS_Com_00693, SWS_Com_00720, SWS_Com_00721, SWS_Com_00725, SWS_Com_00818, SWS_Com_00838, SWS_Com_00839, SWS_Com_00863, SWS_Com_00874
SRS_Com_02096	The AUTOSAR COM module shall not support fragmentation towards the RTE	SWS_Com_00759, SWS_Com_00760
SRS_Com_02097	AUTOSAR COM and LargeDataCOM shall support dynamical signals with a static maximum length	SWS_Com_00756
SRS_Com_02098	The AUTOSAR COM module shall distinct normal and large signals via its configuration	SWS_Com_00753
SRS_Com_02099	The AUTOSAR COM module shall provide a mechanism to detect out of sequence received I-PDUs	SWS_Com_00587
SRS_Com_02101	The AUTOSAR COM module shall support the incrementing and checking of the I-PDU Counter	SWS_Com_00588, SWS_Com_00687, SWS_Com_00688
SRS_Com_02102	The AUTOSAR COM module shall support the detection of out of sequence I-PDUs	SWS_Com_00590, SWS_Com_00726, SWS_Com_00727, SWS_Com_00834
SRS_Com_02103	The AUTOSAR COM module shall provide a mechanism to detect corrupted received I-PDUs and to recover from this failure mode	SWS_Com_00596, SWS_Com_00597
SRS_Com_02105	The AUTOSAR COM module shall support transmission and reception of replicated I-PDUs	SWS_Com_00596, SWS_Com_00597
SRS_Com_02106	The AUTOSAR COM module shall support the detection of failures when receiving replicated I-PDUs	SWS_Com_00596, SWS_Com_00597
SRS_Com_02107	The AUTOSAR COM module shall cancel transmission	SWS_Com_00708

	requests in case of expired transmissions	
SRS_Com_02112	AUTOSAR COM shall provide a uint8-array based API for signal groups	SWS_Com_00841, SWS_Com_00842, SWS_Com_00843, SWS_Com_00844, SWS_Com_00845, SWS_Com_00846, SWS_Com_00847, SWS_Com_00848, SWS_Com_00849, SWS_Com_00850, SWS_Com_00851, SWS_Com_00852, SWS_Com_00854, SWS_Com_00855
SRS_PduR_06002	The routing configuration shall be updateable at post-build time	SWS_Com_00357, SWS_Com_00361, SWS_Com_00373
SRS_PduR_06055	The signal gateway shall provide a mechanism to route individual signals between I-PDUs in a 1:n fashion	SWS_Com_00377, SWS_Com_00539, SWS_Com_00598, SWS_Com_00872, SWS_Com_00873
SRS_PduR_06056	Signal Groups shall be routed	SWS_Com_00361, SWS_Com_00383, SWS_Com_00735, SWS_Com_00833
SRS_PduR_06061	Routers shall map only signals	SWS_Com_00360, SWS_Com_00361, SWS_Com_00362
SRS_PduR_06064	The signal gateway shall be scalable to zero size and zero resource usage when signal routing is not required	SWS_Com_00370
SRS_PduR_06089	The timeout of a deadline monitored signal shall be ignored by the SigG	SWS_Com_00377, SWS_Com_00701, SWS_Com_00872, SWS_Com_00873
SRS_PduR_06097	A configuration shall be identified by an unique ID number	SWS_Com_00487
SRS_PduR_06098	Signal Gateway Error shall be handled with signal routing	SWS_Com_00442
SRS_PduR_06099	Signal Gateway Error shall be handled with signal group routing	SWS_Com_00442

7 Functional Specification

7.1 Introduction

7.2 General Functionality

7.2.1 AUTOSAR COM basis

The *ISO 17356-4:2005 Road vehicles -- Open interface for embedded automotive applications -- Part 4: OSEK/VDX Communication (COM)* is the functional basis of the AUTOSAR COM module. In this document, it is referenced as [17].

[SWS_Com_00010] [The AUTOSAR COM module shall implement all the functionality and all the APIs of [17] except the features and APIs mentioned in SWS_Com_00013.] (SRS_Com_02037)

[SWS_Com_00011] [If this AUTOSAR COM specification defines functionality in a different way compared to definitions in [17], the AUTOSAR COM module shall implement the functionality defined in this AUTOSAR COM specification.] (SRS_Com_02037)

[SWS_Com_00012] [The AUTOSAR COM module shall in addition implement all those features, that are defined in this AUTOSAR COM specification and that are not part of [17].] (SRS_Com_02037)

[SWS_Com_00013] [The AUTOSAR COM module may implement the following features of [17]. If they are implemented in a specific AUTOSAR COM module, the configuration shall disable them by default. This also applies for all other additional features a specific implementation may provide.] (SRS_Com_02037)

<i>feature in [17]</i>	<i>Rationale</i>	<i>related API in [17]</i>
Mapping of a received network message (within an I-PDU) to more than one message data objects (1:n splitting mechanism)	not required, done by the RTE, see [13]	none
Mapping of an internal message to more than one message data objects (1:n splitting mechanism)	not required, done by the RTE, see [13]	none
Mapping an only locally send message to both an external send message object and an internal receive message object (1:n splitting mechanism)	not required, done by the RTE, see [13]	none
M:1 sending; mapping of messages from multiple senders to one and the same message object	not required, ensured by RTE, see [13]	SendMessage
Queued messages	not required, done by the	GetMessageStatus

<i>feature in [17]</i>	<i>Rationale</i>	<i>related API in [17]</i>
	RTE, see [13]	
Zero size messages	it is possible to set up communication without them functionality is partly covered by Com_TriggerTransmit	SendZeroMessage
Notification mechanisms TASK, FLAG and EVENT	not required, done by the RTE, see [13]	none
Overlapping messages in an I-PDU	no use case, dangerous concept	none
Usage of OIL	OIL is not used to configure the AUTOSAR COM module.	None
Application modes	not needed	GetComApplicationMode
Start-up behavior	replaced by <ul style="list-style-type: none"> • Com_Init • Com_DeInit • Com_IpduGroupStart • Com_IpduGroupStop 	StartCOM, StopCOM, StartCOMExtensions, InitMessage
Start and stop of periodic messages	no use case, is realized by I-PDU group mechanism	StartPeriodic, StopPeriodic
Reentrancy	Not all of the AUTOSAR API calls are reentrant. See Chapter 8.3.	See Chapter 8.3.
Interface to <i>indirect NM</i>	not needed	I_MessageTransfer, I_MessageTimeOut
Sender side filtering	no use case, the filter conditions are still used in the selection of the transmission mode but there is no signal filtering	none
Network-order message callout CPU-order message callout	Only I-PDU callouts with a defined AUTOSAR interface are supported by the AUTOSAR COM module. This is to avoid proprietary solutions.	None
Error hook routine	The AUTOSAR COM module defines an own interface for error reporting instead of using error hooks	COMErrorHook COMError_Name1_Name2 macros COMErrorGetServiceId
Interface for callback routines	The signatures for the used callback function of the AUTOSAR COM module will be explicitly defined within the AUTOSAR COM module's specification.	COMCallback
Internal communication	not required, ensured by RTE, see [13]	SendMessage, ReceiveMessage

Table 1: Excluded features of [17] in the AUTOSAR COM module

7.2.2 Signal Values

The signals sent by the AUTOSAR COM module respectively received by the AUTOSAR COM module could have the values defined in Table 2.

<i>Signal value</i>	<i>Remark</i>
init value	See Chapter 7.3.1.4 for details.
Data invalid value	See Chapter 7.3.4 for details.
<value>	This is the normal case: A valid value after initialization phase, which is sent by the AUTOSAR COM module respectively, received by AUTOSAR COM module.

Table 2: Possible signal values

7.2.3 Endianness Conversion and Sign Extension

[SWS_Com_00675] [The AUTOSAR COM module shall support the following data types:

- boolean
- uint8
- uint16
- uint32
- uint64
- sint8
- sint16
- sint32
- sint64
- uint8[n]
- float32
- float64

The type uint8[n] is mapped to either ComSignalType *UINT8_N* or *UINT8_DYN*.] (SRS_Com_02078, SRS_Com_02094)

[SWS_Com_00007] [The AUTOSAR COM module shall support endianness conversion for all supported signed and unsigned integer data types (see **SWS_Com_00675**).] (SRS_Com_02078)

[SWS_Com_00810] [The AUTOSAR COM module shall treat non-integer data types (e.g. uint8[n] or float32) either like integer data types of the matching size or leave their contents uninterpreted in case their ComSignalEndianness is configured to *OPAQUE*.] (SRS_Com_02078)

[SWS_Com_00472] [The AUTOSAR COM module shall interpret opaque data as uint8[n] and shall always map it to an n-bytes sized signal.] (SRS_Com_02078)

For opaque data endianness, conversion has to be configured to *OPAQUE* (see ECUC_Com_00157).

[SWS_Com_00674] [The AUTOSAR COM module shall extend the endianness conversion defined in [17] Chapter 2.4 to signed data types.] (SRS_Com_02078)

In [17] Chapter 2.4 defines the endianness conversion for unsigned data types. The associated configurations can be found in Chapter 10. See also ECUC_Com_00127 and ECUC_Com_00157.

[SWS_Com_00829] [The AUTOSAR COM module shall extend the endianness conversion defined in [17] Chapter 2.4 to signals of signal groups.] (SRS_Com_02086)

AUTOSAR COM handles signals and group signals equally with respect to endianness conversion.

[SWS_Com_00008] [The AUTOSAR COM module shall extend received data to the size of the ComSignalType of the receive signal (sign extension).] (SRS_Com_02086)

The platform specific representation of signed data has to be taken into account. Negative values of signed data will be mapped correctly.

Example: A 10-Bit signed signal is received and copied by Com_ReceiveSignal to a 16-Bit signed integer variable. If $(-3)_{\text{decimal}}$ is received, the received 10-Bit signal has a value of 1111111101b. While copying it to the 16-Bit integer variable the value will be extended to 1111111111111101b.

[SWS_Com_00723] [The AUTOSAR COM module shall extend the init value (ComSignalInitValue) of a signal to the size of its ComSignalType.] (SRS_Com_02086)

Note that the AUTOSAR COM module will not need to perform sign extensions on sender side as it is guaranteed that the values to be transmitted will always be sign-extended. See also SWS_Com_00785.

[SWS_Com_00579] [The AUTOSAR COM module shall not support sign extension for float32 and float64 data types.] (SRS_Com_02086)

[SWS_Com_00221] [The AUTOSAR COM module shall perform endianness conversion before the I-PDU callout on sender side. For an overview, see Chapter 7.15.] (SRS_Com_02078)

[SWS_Com_00352] [The AUTOSAR COM module shall perform sign extensions and endianness conversion before performing filtering and notification detection on receiver side.] (SRS_Com_02078, SRS_Com_02086)

[SWS_Com_00580] [Beside endianness conversion, the AUTOSAR COM module shall not support further conversions for signals with ComSignalType FLOAT32 or FLOAT64. That is endianness conversion shall be supported but complex conversion or normalizations of fractions, exponents, signs or bias values shall not be supported.] (SRS_Com_02078)

7.2.4 Filtering

[SWS_Com_00694] [The AUTOSAR COM module shall evaluate each filtering condition to either true or false.] (SRS_Com_02037)

[SWS_Com_00695] [The AUTOSAR COM module shall filter out signals only at receiver side.] (SRS_Com_02037)

[SWS_Com_00602] [The AUTOSAR COM module shall use filtering mechanisms on sender side for Transmission Mode Conditions (TMC) but it shall not filter out signals on sender side.] (SRS_Com_02083)

For Transmission Mode Selection (TMS) see Chapters 7.3.3.2 and 7.3.3.3.

The AUTOSAR COM module only provides the following ComFilterAlgorithms of that which are defined in [17], see ECUC_Com_00146:

- *ALWAYS*
- *NEVER*
- *MASKED_NEW_EQUALS_X*
- *MASKED_NEW_DIFFERS_X*
- *MASKED_NEW_DIFFERS_MASKED_OLD*
- *NEW_IS_WITHIN*
- *NEW_IS_OUTSIDE*
- *ONE EVERY_N*

To reduce complexity the AUTOSAR COM module does not support all filters defined in [17]. The not supported filters are either obsolete or special cases of other filters. For example, the filter *NEW_IS_DIFFERENT* is a special case of *MASKED_NEW_DIFFERS_MASKED_OLD* with a fully set mask.

[SWS_Com_00325] [The AUTOSAR COM module shall support all filter mechanisms listed in ECUC_Com_00146, considering the exceptions defined in SWS_Com_00380 and SWS_Com_00439.] (SRS_Com_02037)

[SWS_Com_00380] [For signals with ComSignalType *FLOAT32*, *FLOAT64*, *UINT8_N* or *UINT8_DYN*, the AUTOSAR COM module shall only support ComFilterAlgorithm configured to *ALWAYS*, *NEVER* or *ONE EVERY_N*.] (SRS_Com_02037)

[SWS_Com_00439] [For signals with ComSignalType configured to *BOOLEAN*, the AUTOSAR COM module shall only support ComFilterAlgorithm configured to:

- *ALWAYS*
- *NEVER*
- *MASKED_NEW_EQUALS_X*
- *MASKED_NEW_DIFFERS_X*
- *MASKED_NEW_DIFFERS_MASKED_OLD*
- *ONE EVERY_N*

] (SRS_Com_02037)

[SWS_Com_00764] [For signals and group signals with ComBitSize configured to 0, the AUTOSAR COM module shall not support the filter algorithm *Masked_New_Differs_Masked_Old*.] (SRS_Com_02037)

[SWS_Com_00866] [In case the configured filter condition is MASKED_NEW_DIFFERS_X, MASKED_NEW_EQUALS_X, NEW_IS_OUTSIDE or NEW_IS_WITHIN, the AUTOSAR COM module shall calculate the reception filter by using only the least significant ComBitSize bits of the filter parameters.] (SRS_Com_02037)

[SWS_Com_00273] [If the AUTOSAR COM module filters out a signal on receiver side, i.e. filter condition evaluates to false, the AUTOSAR COM module shall discard that signal and shall not process it. See also SWS_Com_00303.] (SRS_Com_02037)

[SWS_Com_00836] [If the AUTOSAR COM module filters out a group signal on receiver side, i.e. filter condition evaluates to false, the AUTOSAR COM module shall discard the whole signal group and shall not process it.] (SRS_Com_02037)

[SWS_Com_00132] [The AUTOSAR COM module shall support the filtering mechanisms as defined in ECUC_Com_00146 also for signed data types.] (SRS_Com_02037)

In the case a filter is evaluated before a send-API has written the corresponding signal, there needs to be a way to determine the filter state of this signal. Some of the filters require a *new_value* to evaluate the filter. However, this is only available after the signal has been updated using a send-API. Therefore, it is necessary to define the value used by the filter for *new_value* in the period before the first send takes place.

[SWS_Com_00603] [The AUTOSAR COM module shall set the *old_value* of the filtering mechanisms for each signal to the ComSignalInitValue (ECUC_Com_00170) during start-up. See also [17].] (SRS_Com_02037)

[SWS_Com_00604] [Until the application has not updated the *new_value* of the filtering mechanisms for a signal, the AUTOSAR COM module shall use the ComSignalInitValue as the *new_value* for that signal.] (SRS_Com_02037)

The next two requirements clarify the definitions of [17] according to the update of the *old_value* of filters.

[SWS_Com_00302] [If the AUTOSAR COM module evaluates a filter for a signal to true, (value is not filtered out) then the AUTOSAR COM module shall place the value of that signal into *old_value* (as defined in [17]).] (SRS_Com_02037)

[SWS_Com_00303] [When a value is being filtered, if the filter does not allow the passage of the value (i.e. the filter evaluates to false) then the AUTOSAR COM module shall not place that value into *old_value* (as defined in [17]).] (SRS_Com_02037)

[SWS_Com_00231] [In the case of ComFilterAlgorithm is configured to *ONE EVERY N*, the AUTOSAR COM module shall

- set OCCURRENCE to zero when OCCURRENCE == PERIOD
- set FILTER to true, when OCCURRENCE == OFFSET
- increment OCCURRENCE after filter processing

] (SRS_Com_02037)

For definition of OCCURRENCE, FILTER, OFFSET and PERIOD see [17].

Configuring ComFilterAlgorithm to *ONE EVERY N* for a signal has the effect that the signal is passed by the filter (i.e. the filter returns true) once every PERIOD calls of the filter. If the OFFSET parameter is zero then the first time the filter is used the signal is allowed to pass (i.e. filter returns true). If the OFFSET is greater than zero then more than one signal must pass through the filter before it returns true.

In case the I-PDU is started by Com_IpduGroupStart with parameter initialize set to true, the OCCURRENCE is also set to zero, see SWS_Com_00787.

This definition exists to clarify the description of the *ONE EVERY N* filter in [17].

The associated configuration items can be found in Chapter 10, see ECUC_Com_00339.

[SWS_Com_00793] [For a signal with a configured reception filter MASKED_NEW_DIFFERS_MASKED_OLD, the AUTOSAR COM module shall treat the first value received for this signal after a reception deadline monitoring timeout occurred for this signal the same way as if the value has passed the filter criteria.] (SRS_Com_02037)

Hence, the AUTOSAR COM module will let pass any value for the filter MASKED_NEW_DIFFERS_MASKED_OLD after an RX deadline timeout for the associated I-PDU.

7.2.5 Signal Gateway

The AUTOSAR COM module provides an integrated Signal Gateway for forwarding signals and group signals in a 1:n manner.

The routing relations are be statically configured via the ComGwMapping configuration container (see ECUC_Com_00544).

As shown in Figure 4 and Figure 5, the integrated Signal Gateway acts as a receiver for all signals or group signals which are configured as a source for gatewayed signals.

After the Signal Gateway received signal or group signals for routing, it acts immediately as a sender for these signals or group signals respectively. This is shown in Figure 3 and Figure 5. The signal processing does not differ if the integrated Signal Gateway forwards a signal/ group signal or if a Software Component sends it.

Since the gateway relations are statically configured, an optimized Signal Gateway might skip some processing stages for concrete configurations. For example, the endianness conversion is not necessary in certain cases. Of course, such optimizations should not lead to any different logical behavior or different representations on the target bus. Optimizations may only be introduced to increase the Signal Gateway's performance.

As shown in Figure 4 a received signal or group signal might be received on the local ECU and be a source for a gateway action at the same time.

Figure 3 and Figure 4 show shadow buffers only for group signals that are received by the RTE. The integrated Signal Gateway has of course to ensure to handle group signals consistently but there is no predetermined way in which this must be implemented.

[SWS_Com_00370] [The Signal Gateway of the AUTOSAR COM module shall scale down to no size if no signal routing functionality is needed.] (SRS_PduR_06064)

7.3 Normal Operation

7.3.1 Start-Up Behavior

This chapter describes the actions that will be performed during Com_Init.

[SWS_Com_00217] [The AUTOSAR COM module shall initialize each I-PDU during execution of Com_Init (SWS_Com_00432), firstly byte wise with the ComTxIPduUnusedAreasDefault value and then bit wise according to initial values (ComSignalInitValue) of the contained signals and the update-bits (see SWS_Com_00117).] (SRS_BSW_00101)

7.3.1.1 Preconditions

The C initialization code, also known as *start-up code*, initializes global and static variables with the initial values. It must be executed before any call of an AUTOSAR COM module's service.

7.3.1.2 Initialization

[SWS_Com_00128] [The AUTOSAR COM module's initialization function Com_Init (SWS_Com_00432) shall initialize all internal data that is not yet initialized by the *start-up code* e.g. C-structs.] (SRS_BSW_00101)

[SWS_Com_00328] [The AUTOSAR COM module's initialization function Com_Init (SWS_Com_00432) shall not enable Inter-ECU communication.] (SRS_BSW_00101)

This initialization chapter is not complete. Details about initialization of some AUTOSAR COM module's features are described within the different feature chapters.

7.3.1.3 Initialization of Not Used Areas of an I-PDU

[SWS_Com_00015] [The AUTOSAR COM module shall fill not used areas within an I-PDU with a value determined by configuration parameter ComTxIPduUnusedAreasDefault (ECUC_Com_00017) e.g. 0xFF.] (SRS_BSW_00101, SRS_Com_02042)

7.3.1.4 Initialization of Signals and Update-Bits

[SWS_Com_00098] [The AUTOSAR COM module shall initialize each signal of n-bit sized signal type on sender and receiver side with the lower n-bits of its configuration parameter ComSignalInitValue (ECUC_Com_00170).] (SRS_BSW_00101)

The configured ComSignalInitValues (ECUC_Com_00170) are also used for the initialization of the signal in the related I-PDU; see SWS_Com_00217.

The ComSignalInitValue (ECUC_Com_00170) of a signal can be identical to its ComSignalDataInvalidValue (ECUC_Com_00391). These can be different for each signal.

[SWS_Com_00117] [The AUTOSAR COM module shall clear all update-bits during initialization. See also SWS_Com_00059.] (SRS_BSW_00101, SRS_Com_02030, SRS_Com_02058)

7.3.1.5 Initialization of I-PDU Groups

[SWS_Com_00444] [By default, all I-PDU groups shall be in the state stopped and they shall not be started automatically by a call to Com_Init (SWS_Com_00432).] (SRS_Com_00218)

7.3.2 De-Initialization

The AUTOSAR COM module provides the API function Com_DeInit (SWS_Com_00130) for de-initialization of the COM layer. This means, after de-initialization of the layer, no communication via the AUTOSAR COM module is possible and all started I-PDU groups are stopped, see also SWS_Com_00129.

7.3.3 Communication Modes

This chapter defines the signal flow in the AUTOSAR COM module. It further defines the different transmission modes provided by the AUTOSAR COM module. Chapter 7.3.3.2 defines a mechanism to switch between two transmission modes for one I-PDU. The replication of signals is defined in Chapter 7.3.3.4.

Exemplary communication use cases that the AUTOSAR COM module can deal with are shown in Chapter 12.

7.3.3.1 Transfer Properties and I-PDU Transmission Mode

7.3.3.1.1 Signals

The AUTOSAR COM module supports several *transfer properties* for signals and several *transmission modes* for I-PDUs. The definitions in this chapters are based on and are to be completed with the definitions in [17] Chapter 2.3.3.

[SWS_Com_00330] [At any send request of a signal with ComTransferProperty *TRIGGERED* assigned to an I-PDU with ComTxModeMode *DIRECT* or *MIXED*, the AUTOSAR COM module shall immediately (within the next main function at the latest) initiate ComTxModeNumberOfRepetitions plus one transmissions of the assigned I-PDU.] (SRS_Com_02083)

[SWS_Com_00767] [At any send request of a signal with ComTransferProperty *TRIGGERED_WITHOUT_REPETITION* assigned to an I-PDU with ComTxModeMode *DIRECT* or *MIXED*, the AUTOSAR COM module shall immediately (within the next main function at the latest) initiate one transmission of the assigned I-PDU.] (SRS_Com_02083)

[SWS_Com_00734] [At a send request of a signal with ComTransferProperty *TRIGGERED_ON_CHANGE* assigned to an I-PDU with ComTxModeMode *DIRECT* or *MIXED*, the AUTOSAR COM module shall immediately (within the next main function at the latest) initiate ComTxModeNumberOfRepetitions plus one transmissions of the assigned I-PDU, if the new sent signal differs to the locally stored (last sent or init) in length or value.] (SRS_Com_02083)

[SWS_Com_00768] [At a send request of a signal with ComTransferProperty *TRIGGERED_ON_CHANGE_WITHOUT_REPETITION* assigned to an I-PDU with ComTxModeMode *DIRECT* or *MIXED*, the AUTOSAR COM module shall immediately (within the next main function at the latest) initiate one transmission of the assigned I-PDU, if the new sent signal differs to the locally stored (last sent or init) in length or value.] (SRS_Com_02083)

[SWS_Com_00762] [The AUTOSAR COM module shall not support the transfer properties *TRIGGERED_ON_CHANGE* and *TRIGGERED_ON_CHANGE_WITHOUT_REPETITION* for signals and group signals with ComBitSize configured to 0.] (SRS_Com_02037)

The support of the transfer properties *TRIGGERED_ON_CHANGE* and *TRIGGERED_ON_CHANGE_WITHOUT_REPETITION* is not restricted to certain signal types. Hence, they are supported for all possible signal types. This includes even the byte array types, e.g. *UINT8_N*.

The details of the transmission replication mechanism are specified in Chapter 7.3.3.4.

[SWS_Com_00135] [The AUTOSAR COM module shall not initiate transmissions for I-PDUs that have the ComTxModeMode (ECUC_Com_00137) *NONE*.] (SRS_Com_02083)

It is possible to request I-PDUs with ComTxModeMode *NONE* via Com_TriggerTransmit.

A pending signal associated with an I-PDU is transmitted if the I-PDU's transmission is triggered for any reason. For example, if a signal with ComTransferProperty *TRIGGERED* within the same I-PDU is sent or the I-PDU sending is scheduled because of ComTxModeMode *PERIODIC* or *MIXED*.

The bus-timing of I-PDUs can be controlled by send requests of the RTE in combination with the transmission mode and the transfer property as described above. Additionally, the PDU Router, especially in case of FlexRay and LIN, can control it with the service Com_TriggerTransmit. In the latter case, the PDU Router requests I-PDUs to be sent from the AUTOSAR COM module.

The function Com_TriggerTransmit can be called for any I-PDU regardless of its transmission mode. This allows LIN and FlexRay to use all the available transmission modes, particularly for sporadic communication. The NM also uses this mechanism to send user data.

7.3.3.1.2 Signal Groups

In AUTOSAR COM also signal groups and group signals may have a transfer property, defining in combination with the transmission mode, if the I-PDU is sent out in case of an update of a signal group or group signal, respectively.

[SWS_Com_00741] [At any send request of a signal group with ComTransferProperty *TRIGGERED* assigned to an I-PDU with ComTxModeMode *DIRECT* or *MIXED*, the AUTOSAR COM module shall immediately (within the next main function at the latest) initiate ComTxModeNumberOfRepetitions plus one transmissions of the assigned I-PDU.] (SRS_Com_02083)

[SWS_Com_00769] [At any send request of a signal group with ComTransferProperty *TRIGGERED_WITHOUT_REPETITION* assigned to an I-PDU with ComTxModeMode *DIRECT* or *MIXED*, the AUTOSAR COM module shall initiate one transmission of the assigned I-PDU within the next main function at the latest.] (SRS_Com_02083)

[SWS_Com_00742] [Regarding signal groups with ComTransferProperty *TRIGGERED_ON_CHANGE* which do not contain any signals that have an own ComTransferProperty configured:

At any send request of such a signal group assigned to an I-PDU with ComTxModeMode *DIRECT* or *MIXED*, the AUTOSAR COM module shall immediately (within the next main function at the latest) initiate ComTxModeNumberOfRepetitions plus one transmissions of the assigned I-PDU, if at least one new sent group signal differs to the locally stored (last sent or init) in length or value.] (SRS_Com_02083)

[SWS_Com_00743] [Regarding signal groups with ComTransferProperty *TRIGGERED_ON_CHANGE* which contain any signals that have an own ComTransferProperty configured:

At any send request of such a signal group assigned to an I-PDU with ComTxModeMode *DIRECT* or *MIXED*, the AUTOSAR COM module shall immediately (within the next main function at the latest) initiate ComTxModeNumberOfRepetitions plus one transmissions of the assigned I-PDU, if at least one new sent group signal configured with ComTransferProperty *TRIGGERED_ON_CHANGE* differs to the locally stored (last sent or init) in length or value.] (SRS_Com_02083)

[SWS_Com_00770] [At a send request of a signal group with ComTransferProperty *TRIGGERED_ON_CHANGE_WITHOUT_REPETITION* assigned to an I-PDU with ComTxModeMode *DIRECT* or *MIXED*, the AUTOSAR COM module shall immediately (within the next main function at the latest) initiate one transmission of the assigned I-PDU, if at least one new sent group signal differs to the locally stored (last sent or init) in length or value.] (SRS_Com_02083)

7.3.3.2 Selection of the Transmission Mode for one specific I-PDU

I-PDUs carry signals. Because an I-PDU can contain more than one signal, in the following, a method is defined to derive the I-PDU's transmission mode from the state of the signals that are contained in one specific I-PDU.

The AUTOSAR COM module allows configuring statically two different transmission modes for each I-PDU (see SWS_Com_00032). The transmission mode of an I-PDU that is valid at a specific point in time is selected using only the values of the signals that are mapped to this I-PDU.

The signals of one I-PDU that contribute to the selection of one of the two transmission modes as well as the conditions used for the selection of the transmission mode are configured statically, see SWS_Com_00676.

For the selection of the transmission mode, the AUTOSAR COM module treats group signals like normal signals.

[SWS_Com_00676] [For the evaluation of a TMS, the AUTOSAR COM module shall take all those (group) signals into account which configuration include a configured ComFilter container. See included containers of ComSignal and ComGroupSignal.] (SRS_Com_02041)

If a signal of an I-PDU with ComIPduDirection configured to *SEND* has a configuration container ComFilter included, the signal is named to **contribute** to the TMS of this I-PDU. If the configuration container for that signal has no assigned configuration container ComFilter, then it does **not contribute** to a TMS.

[SWS_Com_00677] [If no signal within an I-PDU contributes to the calculation of the TMS, then the AUTOSAR COM module shall evaluate the TMS of this I-PDU as true.] (SRS_Com_02084, SRS_Com_02041)

[SWS_Com_00678] [If the AUTOSAR COM module evaluates the TMC of a contributing signal as true, then the AUTOSAR COM module shall evaluate the TMS as true.] (SRS_Com_02084, SRS_Com_02041)

[SWS_Com_00679] [If the AUTOSAR COM module evaluates no TMC of a contributing signal as true, then the AUTOSAR COM module shall evaluate the TMS as false.] (SRS_Com_02084, SRS_Com_02041)

[SWS_Com_00605] [The AUTOSAR COM module shall define a Transmission Mode Selector, for each I-PDU. See definition of TMS above.] (SRS_Com_02084)

[SWS_Com_00245] [The AUTOSAR COM module shall re-calculate the TMS for an I-PDU, after a contained signal was updated by a call to Com_SendSignal or Com_SendSignalGroup.] (SRS_Com_02084)

[SWS_Com_00763] [For the calculation of the transmission mode with the configured condition *MASKED_NEW_DIFFERS_MASKED_OLD*, the AUTOSAR COM module shall use the least significant ComBitSize bits only.] (SRS_Com_02084)

[SWS_Com_00813] [For the calculation of the transmission mode with a configured condition *MASKED_NEW_DIFFERS_X*, *MASKED_NEW_EQUALS_X*, *NEW_IS_OUTSIDE* or *NEW_IS_WITHIN*, the AUTOSAR COM module shall use all bits of the configured ComSignalType.] (SRS_Com_02084)

Note that a signal with ComFilterAlgorithm configured to *ALWAYS*, will always set the TMS of the respective I-PDU to true. Therefore, care must be taken when defining the signals that contribute to the TMS.

[SWS_Com_00032] [If the TMS of an I-PDU evaluates to true, then the AUTOSAR COM module shall use the ComTxModeMode defined in configuration container ComTxModeTrue (ECUC_Com_00455) for that I-PDU.] (SRS_Com_02082, SRS_Com_02084)

[SWS_Com_00799] [If the TMS for an I-PDU evaluates to false, then the AUTOSAR COM module shall use the ComTxModeMode defined in configuration container ComTxModeFalse (ECUC_Com_00454) for that I-PDU.] (SRS_Com_02082, SRS_Com_02084)

[SWS_Com_00238] [In each of the two TMS states, the rules for combination of transfer properties of signals and transmission modes of I-PDUs shall apply as defined in [17] Section 2.3.] (SRS_Com_02082)

[SWS_Com_00239] [When the TMS state of an I-PDU changes, the AUTOSAR COM module shall use the now valid transmission mode immediately (within the next main function at the latest). That means, first the AUTOSAR COM module shall perform the mode change and after that, the AUTOSAR COM module shall execute any resulting calls to PduR_ComTransmit caused by mode change.] (SRS_Com_02082)

[SWS_Com_00244] [If a change of the TMS causes a change of the transmission mode for an I-PDU, then the AUTOSAR COM module shall restart the timer for the cycle time of the transmission mode *PERIODIC* and *MIXED*.] (SRS_Com_02082)

[SWS_Com_00495] [When a call to `Com_SendSignal` or `Com_SendSignalGroup` results into a change of the transmission mode of a started I-PDU to the transmission mode *PERIODIC* or *MIXED*, then the AUTOSAR COM module shall start the new transmission cycle with a call to `PduR_ComTransmit` within the next main function at the latest. The transmission shall be initiated regardless of the transfer property of the signal or signal group that caused the transmission mode switch. The minimum delay time shall still be respected. See also Figure 5 *The AUTOSAR COM module's interaction model for reception*.] (SRS_Com_02082)

The `ComTxModeTimeOffset` is not respected. It is only respected by explicit I-PDU transmission mode switches, for example by `Com_IpduGroupStart` or `Com_SwitchIpduTxMode`.

[SWS_Com_00582] [If a change of the TMS causes a change to the transmission mode *DIRECT*, an immediate (within the next main function at the latest unless shifted due to the MDT) direct/ n-times transmission to the underlying layer shall be initiated.] (SRS_Com_02082)

The above requirement clarifies the behavior in case the TMS-switch to `ComTxModeMode` *DIRECT* was triggered by a signal with `ComTransferProperty` *PENDING*.

If the `ComTxModeMode` of an I-PDU is configured to *NONE* no transmission will be initiated by AUTOSAR COM. This can be used to prevent transmitting an I-PDU, for example in case the TMS evaluates to false.

[SWS_Com_00478] [The AUTOSAR COM module shall send out an I-PDU at most once within one call of `Com_MainFunctionTx`.] (SRS_Com_02083)

7.3.3.3 Signal Flow and Transmission Mode Selection

After a send request from the RTE for a specific signal, the signal is written to the appropriate I-PDU buffer as defined by configuration, and the selection of the transmission mode of the I-PDUs is done according to Chapter 7.3.3.2.

Figure 2 shows the signal flow:

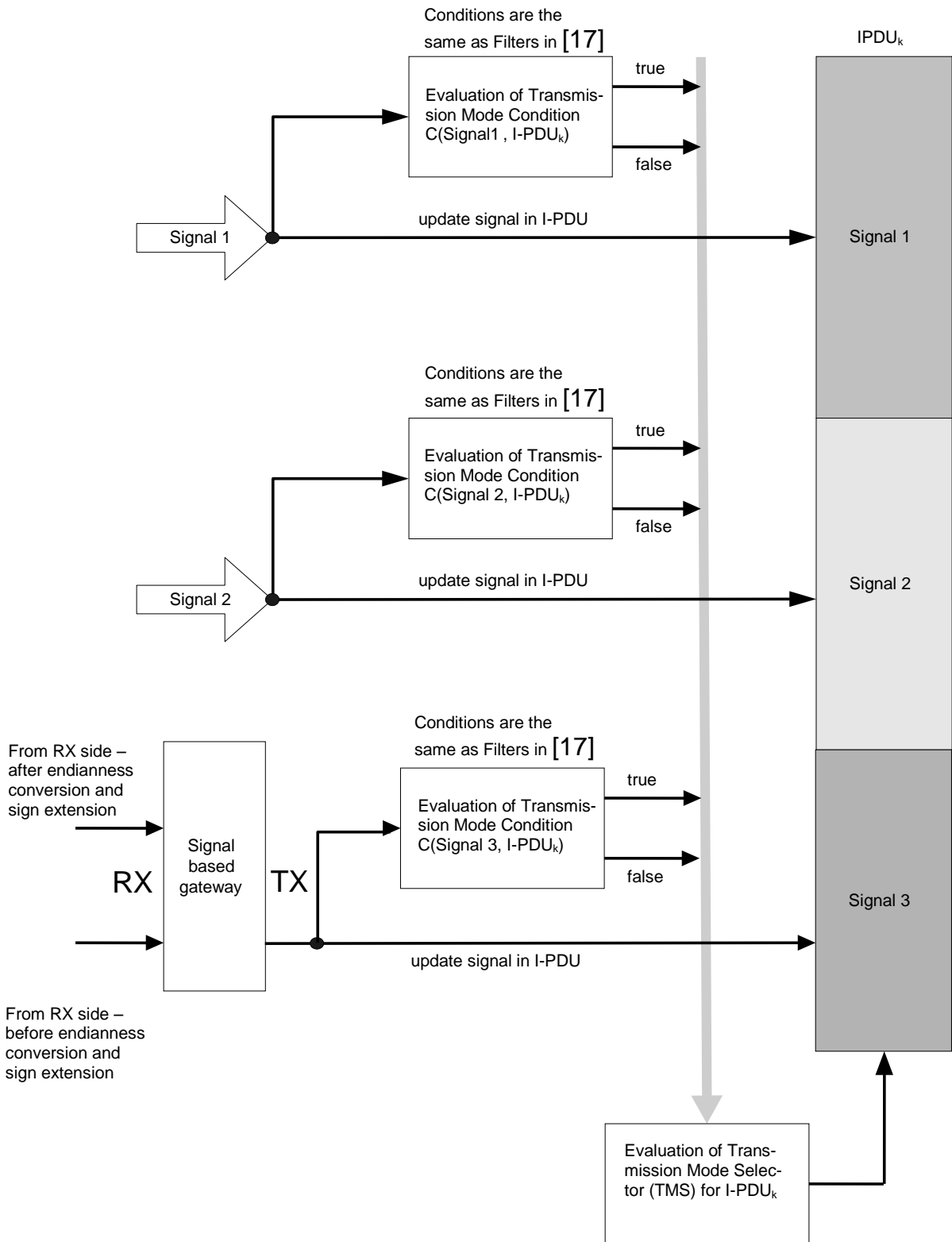

Figure 2: Logical signal flow in the AUTOSAR COM module shown for two signals (Signal1 and Signal2) that are mapped to one I-PDU (IPDU_k)

7.3.3.4 Replication of Signal Transmission Requests

The number of repetitions of transmission requests in the ComTxModeMode *DIRECT* or *MIXED* for a send request by the RTE is defined by configuration parameter ComTxModeNumberOfRepetitions (ECUC_Com_00281).

[SWS_Com_00467] [If ComRetryFailedTransmitRequests is not set to TRUE and an I-PDU with ComTxModeMode *DIRECT* or *MIXED* and ComTxModeNumberOfRepetitions set to 0 is triggered for sending, the AUTOSAR COM module shall invoke PduR_ComTransmit for this I-PDU just once, independently of the result of the confirmation.] (SRS_Com_02083)

Configuring ComTxModeNumberOfRepetitions to 0 imitates the original direct transmission mode of [17].

[SWS_Com_00279] [If a new send request is received from the RTE while sending *n* transmissions belonging together (e.g. after the 3rd of 5 repetitions, see SWS_Com_00305) the AUTOSAR COM module shall cancel the outstanding transmission repetitions and start processing the new request within the next main function at the latest, see Appendix A use-case 4.] (SRS_Com_02080)

[SWS_Com_00305] [In case of sending an I-PDU with ComTxModeMode *DIRECT* or *MIXED* and ComTxModeNumberOfRepetitions greater than 0, the AUTOSAR COM module shall call PduR_ComTransmit periodically, with period ComTxModeRepetitionPeriod until *ComTxModeNumberOfRepetitions plus one* successful confirmations for this send-request are received.] (SRS_Com_02083)

SWS_Com_00305 assumes that CAN does not have a queue for these I-PDUs. There is a race condition in the interaction between the CAN driver, interface and hardware that may cause an extra transmission to occur in certain unlikely circumstances.

If the underlying layer returns E_NOT_OK while an N-Times transmission is in progress, this error notification will be ignored, unless ComRetryFailedTransmitRequests is set to true (see also SWS_Com_00773). As SWS_Com_00305 specifies, only confirmed transmissions are counted for the N-Times transmission, erroneous send request can safely be ignored.

If the N-Times transmission is requested in transmission mode *MIXED* after a cyclic transmission of the *MIXED* transmission mode with a pending confirmation, the confirmation of the cyclic transmission will be assigned to the N-Times transmission. In this case, only *n-1* transmissions of the new value of the N-Times request are observed. The transmission deadline monitoring timer will then be reset earliest after the N-Times request is completed. This must be respected when configuring the transmission deadline monitoring timer in conjunction with the *MIXED* transmission mode and N-Times transmission.

[SWS_Com_00494] [If within the transmission mode *MIXED* an N-Times transmission request overlaps with the cyclic part of the mixed transmission the cyclic trans-

mission shall be counted as the corresponding transmission of the N-Times transmission request.] (SRS_Com_02083)

[SWS_Com_00392] [If a transmission deadline monitoring timeout occurs before the N-Times transmission is complete, then the AUTOSAR COM module shall not initiate further transmissions for this N-Times transmission.] (SRS_Com_02083)

The minimum delay time will always be taken into account as defined in [17] Chapter 2.3.4.

To avoid bursts in start-up a time offset can be configured per I-PDU. See ECUC_Com_00180 for details.

The time between two repetitions is configured by configuration parameter ComTxModeRepetitionPeriod (ECUC_Com_00282).

If the transmission mode change leads to the start of the *MIXED* transmission mode by sending a triggered signal and ComTxModeNumberOfRepetitions is configured greater than or equal to 1, then there will be at least ComTxModeNumberOfRepetitions plus one transmission requests to the PDU Router at the beginning of the *MIXED* transmission mode. See also SWS_Com_00305.

7.3.3.5 Retry Failed Transmission Requests

[SWS_Com_00773] [If ComRetryFailedTransmitRequests is set to TRUE, the return value of PduR_ComTransmit shall be evaluated. If the return value of PduR_ComTransmit is not equal to E_OK, the AUTOSAR COM Module shall invoke PduR_ComTransmit for the not sent I-PDU again within the next Com_MainFunctionTx.] (SRS_Com_02037)

If the I-PDU is updated in between, the new data will be sent.

SWS_Com_00773 may lead to multiple retries for the same failed transmission request.

SWS_Com_00773 is not affected by transmission mode changes.

SWS_Com_00773 has no influence on a potential repetition period. Any repetitions will occur as if no retry had taken place.

[SWS_Com_00774] [The AUTOSAR COM module shall start the transmission deadline monitoring independently of possible retries. Subsequent retries shall not affect transmission deadline monitoring.] (SRS_Com_02037)

[SWS_Com_00775] [If ComRetryFailedTransmitRequests is set to True and a transmission deadline monitoring timeout occurs for an I-PDU, the AUTOSAR COM module shall expire any pending transmission request for this I-PDU.] (SRS_Com_02037)

[SWS_Com_00776] [The cycle timer for a cyclic transmission shall always start with the first transmit attempt.] (SRS_Com_02037)

7.3.4 Signal Invalidation

The AUTOSAR COM module provides the possibility for the sender to indicate that it is not able to provide a valid value for a corresponding signal, for example in case a sensor is faulty. The AUTOSAR COM module allows defining a ComSignalDataInvalidValue (ECUC_Com_00391) during configuration.

7.3.4.1 Transmission of an Invalidated Signal

[SWS_Com_00099] [By a call to Com_InvalidateSignal, the AUTOSAR COM module shall perform internally a Com_SendSignal with the configured ComSignalDataInvalidValue (ECUC_Com_00391).] (SRS_Com_02077)

The ComTransferProperty and the transmission mode determine the transmission of the ComSignalDataInvalidValue on the bus. The internally performed Com_SendSignal with the data invalid value leads to data invalid value to be used as current value for filters and TMS.

The data invalid values are configured per group signal see ECUC_Com_00520.

The VFB defines only one attribute for a complex data type. Therefore, the best mapping of an invalidated complex data type to an invalidated signal group is to invalidate all group signals of a signal group. Therefore, the RTE can also request to invalidate the complete signal group by a call to Com_InvalidateSignalGroup (SWS_Com_00557).

7.3.4.2 Reception of an Invalidated Signal

[SWS_Com_00680] [If the configured ComSignalDataInvalidValue (ECUC_Com_00391) is received for a signal and the ComDataInvalidAction (ECUC_Com_00314) is configured to **NOTIFY** for this signal, the AUTOSAR COM module shall notify the RTE via the configured ComInvalidNotification function (ECUC_Com_00315). In this case, no other signal processing like filtering or the normal signal indication shall take place.] (SRS_Com_02079)

The reception deadline monitoring timer is also restarted in case of receiving an invalid signal or signal group, see SWS_Com_00738.

[SWS_Com_00681] [If the configured ComSignalDataInvalidValue (ECUC_Com_00391) is received for a signal and the ComDataInvalidAction (ECUC_Com_00314) is configured to **REPLACE** for this signal, the AUTOSAR COM module shall replace the signal's value by its configured ComSignalInitValue (ECUC_Com_00170). After the replacement, the normal signal processing like filtering and notification shall take place as if the ComSignalInitValue would have been

received instead of the ComSignalDataInvalidValue.] (SRS_Com_02079, SRS_Com_02087)

[SWS_Com_00682] [If the configured ComSignalDataInvalidValue (ECUC_Com_00391) is received for at least one group signal of a signal group and the ComDataInvalidAction (ECUC_Com_00314) is configured to **NOTIFY** for this signal group, the AUTOSAR COM module shall notify the RTE via the configured ComInvalidNotification function (ECUC_Com_00315). In this case, no other signal group/ group signal processing like the normal indication shall take place.] (SRS_Com_02079)

[SWS_Com_00683] [If the configured ComSignalDataInvalidValue (ECUC_Com_00391) is received for at least one group signal of a signal group and the ComDataInvalidAction (ECUC_Com_00314), is configured to **REPLACE** for this signal group, the AUTOSAR COM module shall replace all group signals of this signal group by their configured ComSignalInitValue values. After the replacement, the normal signal group/ group signal processing like reception notification shall take place as if the ComSignalInitValue would have been received for all group signals.] (SRS_Com_02087)

[SWS_Com_00717] [If the configured ComSignalDataInvalidValue is received for a signal and its ComDataInvalidAction is configured to **NOTIFY**, the AUTOSAR COM module shall not store the received ComSignalDataInvalidValue into the signal object.] (SRS_Com_02079)

The next call to Com_ReceiveSignal will return the last valid received signal or the ComSignalInitValue in case no signal was received yet respectively.

[SWS_Com_00718] [If the configured ComSignalDataInvalidValue is received for at least one group signal of a signal group and its ComDataInvalidAction is configured to **NOTIFY**, the AUTOSAR COM module shall not store any of the received group signals into the signal objects.] (SRS_Com_02079)

The next call to Com_ReceiveSignalGroup will copy the last valid received group signals or the ComSignalInitValues in case the signal group was not received yet respectively into the shadow buffer.

7.3.5 Handling of I-PDUs

7.3.5.1 I-PDU Group Definitions

For an I-PDU group the following rules apply:

1. An I-PDU can belong to any I-PDU group.
2. An I-PDU is active (started) if it belongs to a started I-PDU group (see SWS_Com_00771) or it does not belong to any I-PDU group and it was started implicitly (see SWS_Com_00840).
3. The maximum number of I-PDU groups is pre-compile configurable.
4. I-PDU groups may contain only I-PDUs of the same direction (i.e. send or receive), see SWS_Com_00871.

Rules 1 and 3 are supported by the COM configuration. The maximum number of supported I-PDU groups can be configured via ComSupportedIpdudGroups (ECUC_Com_00710).

[SWS_Com_00771] [An I-PDU is active (started) if at least one I-PDU group is active (started) it belongs to.] (SRS_Com_00218)

For the AUTOSAR COM module, the nesting of I-PDU groups is purely conceptual and must be resolved by an appropriate configuration and/ or usage of the AUTOSAR COM module.

For example, if an I-PDU “BUS1 RX Function1” belongs to I-PDU group “BUS1 RX” and I-PDU group “BUS1 RX” is included in I-PDU group “BUS1” then I-PDU “BUS1 RX Function1” must also be included in I-PDU group “BUS1”. Such dependencies need to be resolved at configuration time.

Once again, the COM module does not know or handle any grouping of I-PDUs. Any I-PDU grouping must be handled either via configuration or by the calling module.

Further, it is expected that the complete state handling of I-PDU groups is done outside of the AUTOSAR COM module, e.g. within the Basic Software Mode Manager. In case of a state change, the module managing the I-PDU group states consistently starts or stops the I-PDU groups via Com_IpdudGroupStart and Com_IpdudGroupStop.

The state of I-PDUs that are not assigned to any I-PDU group cannot be changed, therefore they are started implicitly:

[SWS_Com_00840] [If an I-PDU is not assigned to any I-PDU group, the AUTOSAR COM shall start this I-PDU within Com_Init as if it would be started by Com_IpdudGroupStart with parameter Initialize set to true (see Chapter 7.3.5.2).] (SRS_Com_00218)

Since the AUTOSAR COM never stops such an I-PDU implicitly and it is not assigned to any I-PDU group, such an I-PDU can never be stopped.

7.3.5.2 Starting of I-PDU Groups

By default all I-PDU groups are stopped, see SWS_Com_00444. A call to Com_IpduGroupStart starts an I-PDU group if it was previously stopped.

[SWS_Com_00114] [If an I-PDU is started by Com_IpduGroupStart, the AUTOSAR COM module shall permit to transmit/ receive its signals and signal groups, see also Table 4.] (SRS_Com_00218)

[SWS_Com_00787] [If an I-PDU is started by Com_IpduGroupStart, the AUTOSAR COM module shall always initialize the following attributes of this I-PDU:

- 1) ComMinimumDelayTime of I-PDUs in transmission mode *DIRECT* or *MIXED*
- 2) restart all reception deadline monitoring timers for all signals with a non-zero configured ComFirstTimeout
- 3) cancel all transmission deadline monitoring timers and use ComFirstTimeout (if configured) as value when a transmission timer is started the first time after the I-PDU activation
- 4) all included update-bits shall be cleared
- 5) reset *OCCURRENCE* of filters with ComFilterAlgorithm *ONE_EVERY_N*
- 6) set the I-PDU counter to 0 for I-PDUs with ComIPduDirection configured to *SEND*
- 7) accept for I-PDUs with ComIPduDirection configured to *RECEIVED* any next incoming I-PDU counter] (SRS_Com_00218)

[SWS_Com_00222] [If an I-PDU is started by Com_IpduGroupStart with parameter Initialize set to true, the AUTOSAR COM module shall additionally to SWS_Com_00787 initialize the following attributes of this I-PDU:

- 1) the data of the I-PDU as defined in SWS_Com_00217
- 2) the shadow buffers of included signal groups
- 3) old_value of the filtering mechanisms for each signal to the ComSignalInitValue
- 4) ComTxModeTimePeriod and ComTxModeTimeOffset of I-PDUs in Periodic or MIXED transmission mode] (SRS_Com_00218)

[SWS_Com_00223] [If an I-PDU is started by Com_IpduGroupStart, the AUTOSAR COM module shall determine its transmission mode according to its current data content.] (SRS_Com_00218)

[SWS_Com_00228] [In some cases, an I-PDU is started by Com_IpduGroupStart before all its contained signals have been written. In this case, the AUTOSAR COM module shall use the ComSignalInitValue for the missing signal data.] (SRS_Com_00218)

[SWS_Com_00229] [When an I-PDU is started and one or more signals in that I-PDU have already been written via one of the send APIs by the upper layer, the AUTOSAR COM module shall use the most recently obtained values to determine the TMS of the I-PDU.] (SRS_Com_00218)

[SWS_Com_00733] [If an I-PDU is started by Com_IpduGroupStart and the I-PDU contains signals that have deadline monitoring configured (ECUC_Com_00183,

ECUC_Com_00263), the AUTOSAR COM module shall start the deadline monitoring for these signals independently of the value of the initialize parameter.] (SRS_Com_00218)

Note, in case an I-PDU is started by Com_IpduGroupStart and the parameter initialize is set to false, the internal buffers are not changed and the I-PDU contains the last the last set or init values. Particular, if the I-PDU is started for the first time and initilaize is set to false, the COM operates on the init-values set by Com_Init.

[SWS_Com_00877] [If an I-PDU is not part of any I-PDU Group, it is started during the initialization of COM. Its starting transmission mode shall be evaluated according to the ComSignalInitValue of the signals contributing to its TMS.] (SRS_Com_00218)

For this case, the evaluation can already be done at configuration time, since the signals cannot be written before the initialization of COM.

7.3.5.3 Stopping of I-PDU Groups

A call to Com_IpduGroupStop stops an I-PDU group, if it was previously started.

In order to disable the transmission of an I-PDU, all I-PDU groups containing this I-PDU needs to be stopped. Hence, to implement **listen-only-mode**, all I-PDU groups containing transmission I-PDUs needs to be stopped. Receiving of I-PDUs may also be stopped.

[SWS_Com_00334] [By a call to the functions: Com_SendSignal, Com_SendSignalGroup, or Com_InvalidateSignal, the AUTOSAR COM module shall update the values of its internal buffers even for stopped I-PDUs. See also Table 3.] (SRS_Com_00218)

If a signal written to a stopped I-PDU would trigger the transmission of this I-PDU if it were not stopped, then this trigger is not stored. After re-starting the corresponding I-PDU group, such an old trigger does not lead to an immediate transmission of the I-PDU.

[SWS_Com_00777] [If an I-PDU is stopped by Com_IpduGroupStop, the AUTOSAR COM module shall cancel any outstanding transmission requests for this I-PDU. This includes cancelling any potential retries with respect to ComRetryFailedTransmitRequests.] (SRS_Com_00218)

[SWS_Com_00115] [If an I-PDU is stopped by Com_IpduGroupStop, the AUTOSAR COM module shall cancel the deadline monitoring for all pending confirmations.] (SRS_Com_00218)

[SWS_Com_00800] [The AUTOSAR COM module shall ignore any transmit confirmations for a stopped I-PDU.] (SRS_Com_00218)

The AUTOSAR COM module cannot prohibit the invocation of the Com_Trigger-Transmit function. However, in case of a stopped I-PDU, the function Com_Trigger-Transmit returns E_NOT_OK. See SWS_Com_00001.

[SWS_Com_00684] [If an I-PDU is stopped by Com_IpduGroupStop, the AUTOSAR COM module shall disable its reception processing.] (SRS_Com_00218)

[SWS_Com_00713] [If a large I-PDU is stopped by Com_IpduGroupStop, the AUTOSAR COM module shall stop the reception process and ignore the partly received I-PDU.] (SRS_Com_00218)

[SWS_Com_00685] [If an I-PDU is stopped by Com_IpduGroupStop, the AUTOSAR COM module shall cancel its deadline monitoring.] (SRS_Com_00218)

[SWS_Com_00479] [If an I-PDU is stopped by Com_IpduGroupStop, the AUTOSAR COM module shall immediately invoke the configured ComErrorNotification (ECUC_Com_00499), for outstanding not confirmed transmitted signals/ signal groups of the stopped I-PDU.] (SRS_Com_00218)

[SWS_Com_00714] [If a large I-PDU is stopped while its transmission is already in progress, the AUTOSAR COM module shall stop the transmission process immediately.] (SRS_Com_00218)

Table 3 gives an overview of the behavior of stopped I-PDUs:

Behavior of stopped I-PDUs	
Receiver side (RX)	Transmitter side (TX)
<ul style="list-style-type: none"> • Disable RX deadline monitoring • No action on a Com_RxIndication to RTE, no storing of the I-PDU • Return code COM_SERVICE_NOT_AVAILABLE on Com_ReceiveSignal and Com_ReceiveSignalGroup and the last known value (or init value) is given back as data 	<ul style="list-style-type: none"> • Disable sending • Disable TX deadline monitoring • Ignore Com_TxConfirmation: • On a call of Com_SendSignal, Com_SendSignalGroup, Com_InvalidateSignal and the values in the AUTOSAR COM module's internal buffers are still up-dated but the return code COM_SERVICE_NOT_AVAILABLE is returned • Outstanding transmission request (e.g. N-Times) will be cancelled • Return code E_NOT_OK on Com_TriggerTransmit
	For periodic (TX)
	Do not send any more

Table 3: Behavior of stopped I-PDUs

Table 4 gives an overview of the behavior of started I-PDUs:

Behavior of started I-PDUs	
Receiver side (RX)	Transmitter side (TX)
<ul style="list-style-type: none"> Reinitialize timeouts if Initialize==true (ComSignalFirstTimeout, ComSignalTimeout) Normal reaction on Com_RxIndication/ Com_TpRxIndication Normal reaction on Com_ReceiveSignal, and Com_ReceiveSignalGroup 	<ul style="list-style-type: none"> Normal reaction on Com_InvalidateSignal, Com_SendSignal, and Com_SendSignalGroup No transmission timeout notification until next send Normal reaction on Com_TxConfirmation/ Com_TpTxConfirmation Normal reaction on Com_TriggerTransmit
	For periodic (TX)
	Start at 0

Table 4 Behavior of started I-PDUs

7.3.5.4 Signal Indication (Unpacking of I-PDUs)

In order to support both interrupt-driven and polled systems, it can be configured when the signal indication takes place. There are two configurable signal indication modes *IMMEDIATE* and *DEFERRED* configurable via ComIPduSignalProcessing. See ECUC_Com_00119.

[SWS_Com_00300] [If ComIPduSignalProcessing for an I-PDU is configured to *IMMEDIATE*, the AUTOSAR COM module shall invoke the configured ComNotifications for the included signals and signal groups within the Com_RxIndication, or Com_TpRxIndication function respectively.] (SRS_Com_02046)

[SWS_Com_00301] [If ComIPduSignalProcessing for an I-PDU is configured to *DEFERRED*, the AUTOSAR COM module shall first copy the I-PDU's data within the Com_RxIndication function or the related TP reception functions respectively from the PduR into COM. Then the AUTOSAR COM module shall invoke the configured ComNotifications for the included signals and signal groups asynchronously during the next call to Com_MainFunctionRx.] (SRS_Com_02046)

If in *DEFERRED* mode a call to Com_ReceiveSignal is made before the deferred unpacking takes place, the previous not updated values are returned.

A sequence chart with both indication options can be found in Chapter 9.3. The configuration of these modes is defined in ECUC_Com_00119.

[SWS_Com_00574] [When unpacking an I-PDU, the AUTOSAR COM module shall check the received data length (PduInfoPtr->SduLength) and unpack and notify only completely received signals via ComNotification.] (SRS_Com_02046)

[SWS_Com_00870] [In case of receiving a smaller I-PDU than the length derived via the parameter ComPduIdRef, signals with size 0 shall be received if and only if their configured position is less or equal to the received size of the partially received I-PDU.] (SRS_Com_02046)

[SWS_Com_00794] [In case of receiving of a smaller I-PDU than expected results into receiving a signal without its configured update-bit, the AUTOSAR COM module shall treat this signal as if its update bit was set and interpret such a signal as updated.] (SRS_Com_02046)

If the received I-PDU length is smaller than the configured/ expected I-PDU length, it needs to be prevented that signals are updated partially. On the other hand all completely received signals should be received and notified to the upper layer.

[SWS_Com_00575] [When unpacking an I-PDU, the AUTOSAR COM module shall check the received data length (`PduInfoPtr->SduLength`) and in case a signal group is received only partially, such a signal group and all included group signals shall not be unpacked or notified via `ComNotification`.] (SRS_Com_02046)

The above requirement prevents inconsistently received signal groups and therefore inconsistently received complex data types.

The AUTOSAR COM module does not copy or handle additional received data for not configured signals in case the received data length is greater than expected.

7.3.5.5 Minimum Delay Timer (MDT)

The AUTOSAR COM module inherits the minimum delay timer mechanism as defined [17]. This mechanism is clarified and detailed in this chapter.

When an I-PDU is started, the MDT is re-initialized. Therefore, the MDT can be violated by stopping and starting I-PDUs rapidly.

The behavior of the transmission deadline monitoring timer is not affected by any transmission delay caused by the minimum delay time supervision.

[SWS_Com_00471] [No minimum delay time monitoring shall take place, if `ComMinimumDelayTime` is omitted or configured to 0.] (SRS_Com_02037)

[SWS_Com_00789] [If `ComEnableMDTForCyclicTransmission` (`ECUC_Com_00788`) is configured to false, the minimum delay timer shall not be (re)started in the following cases:

- I-PDUs with `ComTxModeMode` PERIODIC
- the cyclic part of I-PDUs with `ComTxModeMode` MIXED
- repeated transmissions for I-PDUs in case `ComTxModeNumberOfRepetitions` > 0

] (SRS_Com_02037)

In case the minimum delay timer is currently not started, there is no way for the minimum delay timer to expire. Thus, optimized implementations might for example omit monitoring the minimum delay time for periodic I-PDUs completely in case `ComEnableMDTForCyclicTransmission` is configured to false, since the minimum delay timer never gets started.

[SWS_Com_00698] [If ComMinimumDelayTime of an I-PDU is configured greater than 0 and ComRetryFailedTransmitRequests is set to *FALSE*, the AUTOSAR COM module shall load and start the minimum delay time counter upon transmission of that I-PDU to the PDU Router via PduR_ComTransmit.] (SRS_Com_02037)

[SWS_Com_00828] [If ComMinimumDelayTime of an I-PDU is configured greater than 0 and ComRetryFailedTransmitRequests is set to *TRUE*, the AUTOSAR COM module shall load and start the minimum delay time counter upon transmission of that I-PDU to the PDU Router via PduR_ComTransmit only in case PduR_ComTransmit returns E_OK.] (SRS_Com_02037)

[SWS_Com_00469] [If ComMinimumDelayTime of an I-PDU is configured greater than 0, the AUTOSAR COM module shall (re-)load an already running and not yet elapsed minimum delay time counter of that I-PDU with ComMinimumDelayTime on a successful transmit confirmation.] (SRS_Com_02037)

The running minimum delay timer is reloaded upon the reception of a successful TX-confirmation of that I-PDU, unless the transmission was already delayed longer than ComMinimumDelayTime at the reception of the confirmation. In normal case, there will be no further transmission of that I-PDU by the AUTOSAR COM module unless the loaded and started minimum delay has expired. See also Figures 2-4, 2-5 and 2-7 in [17]. However, some exception exists: According to SWS_Com_00475 Com_TriggerTransmit does not interfere with the minimum delay timer. Further, the minimum delay timer is reset if the transmission deadline monitoring timer expires; see Chapter 2.3.4 in [17]. In addition, starting an I-PDU group resets the minimum delay time timer of the included I-PDUs.

[SWS_Com_00812] [If the minimum delay timer of an I-PDU is reset because the transmission deadline monitoring timer expires and a postponed request for this I-PDU exists, the AUTOSAR COM module shall immediately transmit this I-PDU.] (SRS_Com_02037)

7.3.6 Deadline Monitoring

Deadline monitoring for signals is defined in [17].

In the context of deadline monitoring for a signal group, it is handled like a signal. The deadline monitoring parameters ComFirstTimeout and ComTimeout can be defined in the configuration container ComSignal or ComSignalGroup.

The corresponding timeout notification callback functions can be defined in parameter ComTimeoutNotification in the configuration container ComSignal or ComSignalGroup.

[SWS_Com_00333] [If the configuration parameter ComTimeout for a signal or signal group is omitted or configured to 0, the AUTOSAR COM module shall not monitor this signal or signal group. It also shall ignore the ComFirstTimeout.] (SRS_Com_02089)

7.3.6.1 Reception Deadline Monitoring

The reception deadline monitoring can be enabled and disabled by the control of I-PDU groups analogous to Chapter 7.3.5.1.

[SWS_Com_00772] [The reception deadline monitoring of an I-PDU is enabled if and only if it is contained in an I-PDU group that has reception deadline monitoring enabled. Otherwise, the reception deadline monitoring of the I-PDU is *disabled*.] (SRS_Com_00192)

[SWS_Com_00292] [In the case where reception deadline monitoring is configured for signals with update-bits, the AUTOSAR COM module shall perform a separate reception deadline monitoring for each signal/ signal group with an update-bit. For configuration of ComTimeout, see ECUC_Com_00263.] (SRS_Com_02089, SRS_Com_02058)

[SWS_Com_00290] [The AUTOSAR COM module shall perform an I-PDU based reception deadline monitoring for signals without an update-bit.] (SRS_Com_02089, SRS_Com_02058)

[SWS_Com_00291] [For all signals and signal groups without update-bits within the same I-PDU, the AUTOSAR COM module shall perform the reception deadline monitoring of the I-PDU using the smallest configured non-zero timeout parameter (ComFirstTimeout, ComTimeout) of all these signals and signal groups which do not have an update-bit configured.] (SRS_Com_02089, SRS_Com_02058)

If all signals within an I-PDU with configured reception deadline monitoring have also an update-bit configured, no reception deadline monitoring on I-PDU base needs to be performed.

In case of an Rx-timeout, the ComRxDataTimeoutAction parameter determines whether the AUTOSAR COM module replaces the signal/ signal group value with the initial value or substitute value or maintains the last received value. See ECUC_Com_00412.

[SWS_Com_00470] [If ComRxDataTimeoutAction is set to *REPLACE* (see ECUC_Com_00412), the AUTOSAR COM module shall replace the signal's value by its ComSignalInitValue (see ECUC_Com_00170) when the reception deadline monitoring timer of a signal expires.] (SRS_Com_02087, SRS_Com_02088)

In case the ComSignalInitValue replaces the last received value, the last received value is overwritten and gets lost. Therefore, the AUTOSAR COM module returns the ComSignalInitValue for this signal until a new value is received.

[SWS_Com_00875] [If ComRxDataTimeoutAction is set to *SUBSTITUTE* (see ECUC_Com_00412), the AUTOSAR COM module shall replace the signal's value by its ComTimeoutSubstitutionValue (see ECUC_Com_10006) when the reception deadline monitoring timer of a signal expires.] (SRS_Com_02088)

[SWS_Com_00500] [If the reception deadline monitoring timer of a signal or signal group expires and the configuration parameter ComRxDataTimeoutAction for this signal or signal group is either omitted or configured to *NONE*, the AUTOSAR COM module shall not replace the signal or the signals of the signal groups respectively.] (SRS_Com_02087)

[SWS_Com_00513] [If ComRxDataTimeoutAction is set to *REPLACE* (see ECUC_Com_00412), the AUTOSAR COM module shall replace the values of all included group signals by their ComSignalInitValues (see ECUC_Com_00170), when the reception deadline monitoring timer of a signal group expires.] (SRS_Com_02041)

The Rx-timeout-indication can be combined and configured separately from ECUC_Com_00412.

[SWS_Com_00876] [If ComRxDataTimeoutAction is set to *SUBSTITUTE* (see ECUC_Com_00412), the AUTOSAR COM module shall replace the values of all included group signals by their ComTimeoutSubstitutionValue (see ECUC_Com_10006), when the reception deadline monitoring timer of a signal group expires.] (SRS_Com_02088)

[SWS_Com_00715] [When a (large) I-PDU with a configured reception deadline monitoring is received successfully, the AUTOSAR COM module shall reset the reception deadline monitoring timer for this (large) I-PDU at invocation of the function Com_RxIndication or Com_TpRxIndication respectively.] (SRS_Com_02058)

[SWS_Com_00716] [If the configuration parameter ComFirstTimeout for a signal or signal group is omitted or configured to 0, the AUTOSAR COM module shall not monitor the reception of this signal or signal group respectively from the start of the corresponding I-PDU until the first reception.] (SRS_Com_02058)

[SWS_Com_00738] [The I-PDU based reception deadline monitoring mechanism shall not take the values of the signals into account.] (SRS_Com_02089)

7.3.6.1.1 En-/Disable Reception Deadline Monitoring

When reception deadline monitoring of an I-PDU is disabled and the timer expires, no error indication will be given to the RTE.

Disabling reception deadline monitoring does not stop the reception of an I-PDU.

[SWS_Com_00224] [If the reception deadline monitoring of an I-PDU is enabled by Com_EnableReceptionDM, the AUTOSAR COM module shall set the reception deadline monitoring timer for the included signals and signal groups to the configured ComFirstTimeout value.] (SRS_Com_00192)

[SWS_Com_00486] [The AUTOSAR COM module shall silently ignore setting the reception deadline monitoring of an I-PDU to enabled by Com_EnableReceptionDM,

in case the reception deadline monitoring is already enabled for this I-PDU.] (SRS_Com_00192)

Enabling reception deadline monitoring implies that timeout notifications of deadline monitoring expiry are notified to the RTE for signals or signal groups with a configured ComTimeoutNotification (ECUC_Com_00552).

[SWS_Com_00534] [If Com_EnableReceptionDM or Com_DisableReceptionDM is invoked on an I-PDU group containing Tx-I-PDUs, then the AUTOSAR COM module shall silently ignore this request.] (SRS_Com_00192)

[SWS_Com_00225] [The AUTOSAR COM module shall silently ignore setting the reception deadline monitoring of an I-PDU to disabled by Com_DisableReceptionDM, in case the reception deadline monitoring is already disabled for this I-PDU.] (SRS_Com_00192)

7.3.6.2 Transmission Deadline Monitoring

The general idea of the AUTOSAR COM transmission deadline monitoring is to supervise the lower layers and the bus but not the COM module itself. Hence, the transmission monitoring timer is generally started, when the COM module sends an I-PDU to the lower layer. This is independent of a transmission mode, a transfer property or update-bits. In general the transmission monitoring timer is not restarted or reset if it is currently running.

[SWS_Com_00481] [The AUTOSAR COM module shall perform the transmission deadline monitoring (if configured) for all signals and signal groups independently from the transfer property and independently from the transmission modes of the I-PDU the signal / signal group belongs to.] (SRS_Com_02037)

The AUTOSAR COM module makes no distinction between signals with ComTransferProperty *PENDING* or *TRIGGERED* with respect to transmission deadline monitoring.

[SWS_Com_00445] [If different ComTimeout parameters of the associated signals/signal groups of an I-PDU are configured, the AUTOSAR COM module shall use the smallest value as timeout parameter for the transmission deadline monitoring of the I-PDU.] (SRS_Com_02037)

Transmission deadline monitoring should only be configured in the AUTOSAR COM module for busses that support the generation of transmit confirmations. Otherwise, the transmission deadline monitoring would always notify a transmission error.

[SWS_Com_00878] [The AUTOSAR COM shall start a configured transmission deadline monitoring timer of a signal (group) if it is sent (within an I-PDU) to the lower layer, unless the timer is already running.] (SRS_Com_02037)

SWS_Com_00878 does not consider a potential return code, thus the timer is started even if the sent request fails immediately.

If the timer is already running a new send request does not reset or restart a running timer, but the currently outstanding send request is monitored further on. Unless otherwise specified, the timer is started regardless of the trigger that lead to a potential I-PDU send request. Such triggers are for example a cyclic send request of a signal, a Transmission Mode Switch, or an explicit I-PDU send request via Com_TriggerIPduSend.

[SWS_Com_00879] [The transmission deadline monitoring timer shall be started with the configured ComFirstTimeout value if the timer is started for the first time after a (re-)start of the transmission deadline monitoring service for this I-PDU, otherwise the timer shall be started with ComTimeout value.] (SRS_Com_02037)

[SWS_Com_00880] [When the AUTOSAR COM receives a transmit confirmation for an I-PDU, it shall cancel all running transmission deadline monitoring timers for all contained signals and signal groups.] (SRS_Com_02037)

[SWS_Com_00696] [In case transmission deadline monitoring is configured for an I-PDU with transmission mode *NONE* only, the AUTOSAR COM module shall start the transmission deadline monitoring timer for this I-PDU upon the start of the I-PDU group to which the I-PDU belongs to.] (SRS_Com_02037)

[SWS_Com_00835] [In case transmission deadline monitoring is configured for an I-PDU with transmission mode *NONE* and another transmission mode, the transmission deadline monitoring shall be disabled whenever the transmission mode *NONE* is active.] (SRS_Com_02037)

[SWS_Com_00697] [In case transmission deadline monitoring is configured for an I-PDU with transmission mode *NONE* only, the AUTOSAR COM module shall reset the transmission deadline monitoring timer for this I-PDU when a successful transmit confirmation is received.] (SRS_Com_02037)

In case of a signal group, it is only possible to configure transmission deadline monitoring for the whole signal group and not for group signals, see ECUC_Com_00345 and ECUC_Com_00520.

[SWS_Com_00708] [In case the transmission deadline monitoring timer expires for an I-PDU with ComIPduCancellationSupport configured to *TRUE*, the AUTOSAR COM module shall invoke PduR_ComCancelTransmit for that I-PDU.] (SRS_Com_02107)

The invocation of PduR_ComCancelTransmit is done in addition to the normal timeout handling of Com, which notifies the SW-C, if configured.
The AUTOSAR COM ignores the return code of PduR_ComCancelTransmit.

[SWS_Com_00304] [When a transmission deadline monitoring timer elapses, that is there was no successful transmit confirmation for an I-PDU in time, the AUTOSAR COM module shall notify the RTE by invoking all configured ComTimeoutNotifications for contained signals or signal groups, see ECUC_Com_00552.] (SRS_Com_02037)

If the transmission deadline monitoring timer runs out, there will be a timeout notification regardless of the reason. For example, the notification will even take place, if the transmission was filtered out by an I-PDU callout.

7.3.6.2.1 Transmission Deadline Monitoring with N-Times Transmission Mode

As defined in [17] the monitoring timer has to be started upon completion of a call to `Com_SendSignal` or `Com_SendSignalGroup` respectively if transmission deadline monitoring is configured for the corresponding signal or signal group respectively.

For the transmission mode *DIRECT* and *MIXED*, it should be ensured that all `ComTxModeNumberOfRepetitions` requests could be made within the configured period (see Chapter 7.3.3.4).

As defined in [17], if the monitoring timer expires the RTE is notified with the configured notification mechanism about that failure.

[SWS_Com_00308] [For an I-PDU with `ComTxModeMode` *DIRECT* and `ComTxModeNumberOfRepetitions` > 0, the AUTOSAR COM module shall cancel the transmission deadline monitoring timer after *ComTxModeNumberOfRepetitions plus one* successfully received transmit confirmations.] (SRS_Com_02083)

If the timer is cancelled after *ComTxModeNumberOfRepetitions plus one* confirmations, the transmission was successful and then the transmission confirmation is sent to the RTE. See also SWS_Com_00305.

[SWS_Com_00739] [For an I-PDU with `ComTxModeMode` *DIRECT* and `ComTxModeNumberOfRepetitions` > 0, the AUTOSAR COM module shall reset an already running transmission deadline monitoring timer in case another send request for this I-PDU is initiated.] (SRS_Com_02083)

7.3.7 Notification handling

The AUTOSAR COM inherits the notification classes 1,2,3 and 4 of [17]. The notifications are configurable via `ComNotification` and the definitions of the callbacks are given in Chapter 8.6.3.1.

[SWS_Com_00883] [If a `ComNotification` is configured for a signal or signal group, the AUTOSAR COM shall indicate each successful transmission via the configured notification.] (SRS_Com_02046)

For example, for periodic transmissions each successful periodic transmission is notified. Note that for n-times transmission multiple transmissions on the bus are necessary before it is considered as successful, see also SWS_Com_00305.

7.4 Signal Groups - Complex Data Types

To support the AUTOSAR concept of complex data types the AUTOSAR COM module provides signal groups. The AUTOSAR COM module transmits and receives signal groups consistently to provide the necessary consistency for complex data types.

Signal groups can be configured statically. For each signal group a symbolic name can be configured. See ECUC_Com_00345 for the configuration details.

The AUTOSAR COM module achieves the consistency of a signal group by means of a shadow buffer mechanism, i.e. the RTE accesses the group signals in the shadow buffer. If the shadow buffer needs to be synchronized with the I-PDU, the RTE can trigger this explicitly with `Com_SendSignalGroup` or `Com_ReceiveSignalGroup`. The synchronization is performed atomically.

An alternative approach to signal group consistency is to enable the signal group array APIs `Com_SendSignalGroupArray` (SWS_Com_00851) and `Com_ReceiveSignalGroupArray` (SWS_Com_00854). The deviations of this approach are described in Chapter 7.4.6.

7.4.1 Initialization

[SWS_Com_00484] [By a call to `Com_Init`, the AUTOSAR COM module shall initialize the shadow buffer of a signal group on sender-side.] (SRS_BSW_00101)

Since it is not suspected that a well-formed SWC tries to read a group signal before a call to `Com_ReceiveSignalGroup`, SWS_Com_00484 applies to the sender side only.

7.4.2 Transmission

If `Com_SendSignal` or `Com_InvalidSignal` is called for a signal that belongs to a signal group, then the AUTOSAR COM will only update the shadow buffer of this signal group. There is no need for any further I-PDU processing like TMS evaluation, unless the I-PDU contents changed.

[SWS_Com_00050] [If `Com_SendSignalGroup` is called for the signal group, the AUTOSAR COM module shall copy the shadow buffer atomically to the I-PDU buffer.] (SRS_Com_02041)

Example with two group signals `signal_a` and `signal_b`, which belong to `group_x`:

```
/* copy a to shadow buffer */  
Com_SendSignal (signal_a, &a);  
  
/* copy b to shadow buffer */  
Com_SendSignal (signal_b, &b);  
  
/* copy shadow buffer to I-PDU */  
Com_SendSignalGroup (group_x);
```

7.4.3 Reception

A group signal can be received from the shadow buffer by calling the function `Com_ReceiveSignal` after the signal group data has been copied to the shadow buffer by `Com_ReceiveSignalGroup`.

[SWS_Com_00051] [If `Com_ReceiveSignalGroup` is called for a signal group, the AUTOSAR COM module shall copy the data atomically from the I-PDU buffer to the shadow buffer.] (SRS_Com_02041)

Example with two group signals `signal_a` and `signal_b`, which belong to `group_x`:

```
/* copy I-PDU to shadow buffer */  
Com_ReceiveSignalGroup (group_x);  
  
/* copy a from shadow buffer */  
Com_ReceiveSignal (signal_a, &a);  
  
/* copy b from shadow buffer */  
Com_ReceiveSignal (signal_b, &b);
```

7.4.4 Notifications

Table 5 shows that all notification functions are only configurable for signal groups but not for individual group signals. Chapter 7.3 defines the functional logic of the notification methods for signals and signal groups. The prototypes for the configurable notification functions are defined in Chapter 8.6.3.1.

7.4.5 Attributes of a Signal Group

Table 5 gives an overview of the attributes of a signal group:

Attribute	Per group signal	Per signal group
Update-bit	No	Yes, associated on the whole group (see Chapter 7.8)
Signal Notification (sender side)	No	Yes
Signal Notification (receiver side)	No	Yes
Error Notification (sender side)	No	Yes
Timeout Notification (sender side)	No	Yes
Timeout Notification (receiver side)	No	Yes
Invalid Notification (receiver side)	No	Yes
Data access (receiver side)	Yes	Yes, see SWS_Com_00201
Data access (sender side)	Yes	Yes, see SWS_Com_00200, SWS_Com_00557
Data Filtering (receiver side)	Yes, see Chapter 7.2.4	No
Data Filtering (sender side)	No	No
TMS on sender side	Each signal, according to TMS selection definition. (see Chapter 7.3.3.2)	No

Table 5: Attributes of signal groups

7.4.6 UINT8-array based access to signal groups

An alternative approach to signal group consistency is to enable the signal group array APIs `Com_SendSignalGroupArray` (SWS_Com_00851) and `Com_ReceiveSignalGroupArray` (SWS_Com_00854) via the COM configuration parameter `ComSignalGroupArrayAccess` (ECUC_Com_10003). The serialization of the composite data is then done outside of the COM module but resulting in the same layout as COM would use to place the group signals in the I-PDU.

In this approach, no shadow buffer is used. The serialized data is directly provided to the COM module as a uint8-array representation of the signal group.

[SWS_Com_00841] [The UINT8-array based access to signal groups shall only be used if the following preconditions apply:

- uses only fix sized data types for the composite data
- signal groups, which are mapped byte aligned to the I-PDU
- signal groups, which are not intermitted by other signals (but may contain gaps)

] (SRS_Com_02112)

[SWS_Com_00842] [In case a signal group has `ComSignalGroupArrayAccess` (ECUC_Com_10003) defined, no shadow buffer shall be allocated for that signal group.] (SRS_Com_02112)

[SWS_Com_00843] [In case a signal group has ComSignalGroupArrayAccess (ECUC_Com_10003) defined, the call to the following APIs is not supported for that signal group:

- Com_SendSignal and Com_ReceiveSignal for any of the group signals of that signal group
- Com_SendSignalGroup and Com_ReceiveSignalGroup for that signal group

] (SRS_Com_02112)

The above requirement defines that certain APIs are not supported for signal groups with array access. That is, these APIs must not be called for signal groups with array access. If they are called illegally, the behavior is undefined.

Since the signal group is provided in the uint8-array representation, reception filtering and transmission mode selection needs to cope with this data representation when evaluating the group signals.

In order to ease the filter evaluation only a subset of the filters from SWS_Com_00602 is supported.

For signal group array access the following two filters are excluded from reception filtering and Transmission Mode Selection:

- *NEW_IS_WITHIN*
- *NEW_IS_OUTSIDE*

[SWS_Com_00848] [The signal group array processing functions Com_SendSignalGroupArray and Com_ReceiveSignalGroupArray shall support the following filters for reception filtering and Transmission Mode Selection:

- *ALWAYS*
- *NEVER*
- *MASKED_NEW_EQUALS_X*
- *MASKED_NEW_DIFFERS_X*
- *MASKED_NEW_DIFFERS_MASKED_OLD*
- *ONE EVERY_N*

] (SRS_Com_02112)

7.4.6.1 Basic functionality

In case the AUTOSAR Transformer approach is used the serialization and further data processing is already done in the transformer chain. Since the transformer chain already deals with a uint8-array representation of the communication data, the uint8-array based access to signal groups allows to use the already serialized data and to place it into the I-PDU without the need for COM to serialize the data again.

The AUTOSAR System Template [12] defines which signal group shall be handled in the uint8-array based approach. If the System Template enables the uint8-array based approach the Ecu configuration parameter ComSignalGroupArrayAccess (ECUC_Com_10003) is set to true.

[SWS_Com_00844] [The start position of the uint8-array representation of the communication data shall be the byte offset of the group signal in this signal group with the smallest ComBitPosition.] (SRS_Com_02112)

[SWS_Com_00845] [The length of the uint8-array representation of the communication data shall be the number of bytes which all the ComGroupSignals in this ComSignalGroup occupy in the ComIPdu.] (SRS_Com_02112)

7.4.6.2 Initialization

[SWS_Com_00850] [By a call to Com_Init, the AUTOSAR COM module shall initialize the respective I-PDU buffer section of a signal group, that has ComSignalGroupArrayAccess (ECUC_Com_10003) configured *true*, based on the ComSignalInitValue of all included ComGroupSignals.] (SRS_Com_02112, SRS_BSW_00101)

7.4.6.3 Transmission

[SWS_Com_00846] [When Com_SendSignalGroupArray is called a data pointer to the uint8-array representation of the signal group is provided. The AUTOSAR COM module shall copy the data into the I-PDU based on the start position defined in SWS_Com_00844 and the size defined in SWS_Com_00845.] (SRS_Com_02112)

[SWS_Com_00847] [The AUTOSAR COM module shall handle a call of Com_SendSignalGroupArray equally to Com_SendSignalGroup with respect to

- Chapter 7.3.3.1.2 Signal Groups (Transfer Properties and I-PDU Transmission Mode)
- Chapter 7.3.3.2 Selection of the Transmission Mode for one specific I-PDU
- Chapter 7.3.3.3 Signal Flow and Transmission Mode Selection

] (SRS_Com_02112)

7.4.6.4 Reception

[SWS_Com_00849] [When Com_ReceiveSignalGroupArray is called a data pointer to the uint8-array representation of the signal group is provided. The AUTOSAR COM module shall copy the data to the data pointer position of the I-PDU based on the start position defined in SWS_Com_00844 and the size defined in SWS_Com_00845.] (SRS_Com_02112)

7.5 Large Data Types

A **large signal** is a signal that is too large to fit into a single L-PDU of the underlying communication protocol. For example, a large signal on CAN would exceed 8 bytes or 64 bytes for CAN FD. For FlexRay the situation is more complex, since one frame can contain several I-PDUs. Hence, a signal may be a large signal for FlexRay even if it does not exceed the size of a FlexRay frame.

Large signals in AUTOSAR require configuring a **large I-PDU** that will be transmitted via the transport protocol of the underlying bus. It is not imperative that a large I-PDU contains one or more large signals.

Using this concept the I-PDU length and hence the signal size will be limited according to the bus-specific transport protocol, see ECUC_Com_00437.

UINT8_N is the only signal type that supports signals of a static size larger than 8 bytes. For dynamic length signals see Chapter 7.6.

Since the AUTOSAR COM module is not aware of the underlying bus properties, it has to be configured if an I-PDU can be transmitted within a single L-PDU, e.g. one CAN frame, or if it needs to be transmitted via TP, see also ECUC_Com_00761.

The AUTOSAR COM module is not able to prevent or to detect if too large I-PDUs are sent to a specific bus transport protocol, because the AUTOSAR COM module uses the bus-independent PDU Router interface. However, the AUTOSAR COM module allows that the maximum length of the N-SDU of the underlying TPs can be used and therefore the AUTOSAR COM module does not introduce any additional length restrictions.

7.5.1 Transmission of Large Signals/ I-PDUs

The AUTOSAR COM module sends large I-PDUs via the generic PduR APIs for upper layer modules that use transport protocol. For details of the AUTOSAR COM module – PDU Router interface see Chapter 7.7. According to [10] the call-sequence is:

- PduR_ComTransmit: for initiating the send request
- one or more callbacks to Com_CopyTxData: for copying the data
- callback to Com_TpTxConfirmation: for confirming the transmission

[SWS_Com_00662] [After successful initiation of a transmission of a large I-PDU via PduR_ComTransmit, the AUTOSAR COM module shall not modify the data of its internal transmit buffer of this I-PDU unless the AUTOSAR COM module is notified about either the successful transmission or an error indicating that the transmission was aborted.] (SRS_Com_02095)

The I-PDUs within the AUTOSAR COM module are statically configured. Therefore, the complete memory of the I-PDU, even for very large I-PDUs, will be allocated. This approach was taken in order to reduce the complexity of the large data type handling.

If the utilized transportation protocol is also used for diagnosis, or other services, it must support multiple users. This is at least supported by CAN TP and FlexRay TP.

[SWS_Com_00863] [In case a large I-PDU is currently transmitted and the same I-PDU is triggered for transmission again, the AUTOSAR COM shall skip the additionally send request and report the runtime error COM_E_SKIPPED_TRANSMISSION.] (SRS_Com_02095)

This could for example happen in case a large I-PDU is sent out periodically and the transmission is delayed over the next cycle.

7.5.2 Reception of Large Signals/ I-PDUs

The AUTOSAR COM module receives large I-PDUs via the generic PDU Router's APIs for upper layer modules that use transport protocol. For details of the AUTOSAR COM module – PDU Router interface see Chapter 7.8. According to [10] the call-sequence is:

- call to Com_StartOfReception: for initiating the RX request
- one or more callbacks to Com_CopyRxData: copying the receive data to the AUTOSAR COM module's internal receive buffer
- call to Com_TpRxIndication: indicating the correct, or incorrect, end of the reception process

[SWS_Com_00838] [In case Com_TpRxIndication is called with value E_NOT_OK for the parameter result, the AUTOSAR COM module shall treat all signals of the received large I-PDU exactly like invalidated signals. That is, the AUTOSAR COM module shall execute all configured ComDataInvalidActions for all included signals and signal groups.] (SRS_Com_02095)

When receiving large I-PDUs the internal I-PDU buffer is overwritten gradually. Thus, unless the old signal is not stored somewhere else (for example in a shadow buffer of a signal group), the COM module runs the risk to lose signal data information that might be needed in certain scenarios, for example:

- receiving a signal with an unset update-bit
- providing the last value in case the RX-filter is not passed
- providing the last value in case there is only an invalid notification (but no replacement) is defined and the invalid value is received

[SWS_Com_00882] [If the AUTOSAR COM module receives signals via large I-PDUs and these signals have features configured that need to keep the old value in certain cases, the AUTOSAR COM module shall correctly provide the old value for signals received via a large I-PDU in the same way as for signals received via normal I-PDUs.] (SRS_Com_02041)

It is open to the implementation to find efficient means for providing the old values and to derive from the configuration, which signals or I-PDUs need an additional handling (e.g. buffering).

This does not mean it is necessary to implement a queue.

7.6 Dynamic Length Signals

A **dynamic length signal** is a signal which length can vary at run-time. The maximal length of a dynamic length signal needs to be specified at configuration time. A dynamic length signal has to be transmitted in a **dynamic length I-PDU**.

[SWS_Com_00753] [For dynamic length signals, the AUTOSAR COM module shall only support the ComSignalType *UINT8_DYN.*] (SRS_Com_02094, SRS_Com_02098)

Restricting the type to a UINT8-array type also restricts the placement of the dynamic length signal to byte boundaries.

All other signals, potentially including large signals, must be packed in front of the dynamic length signal (see SWS_Com_00754, SWS_Com_00755 and SWS_Com_00756). Therefore, it is not required to encode the length of the dynamic length signal within the I-PDU. On receiver side, the length of the dynamic length signal can be calculated from the length of the received I-PDU.

It is allowed to configure an update-bit for a dynamic length signal. In this case, the update-bit must be located in front of the dynamic length signal, see also SWS_Com_00755.

There is no restriction in the AUTOSAR COM module preventing the usage of signal groups in combination with large or dynamic length signals.

Dynamic length signals are not restricted to be sent via transport protocol. However, the maximum length of the I-PDU containing the dynamic length signal must respect the bus-specific restrictions.

In case of I-PDUs with dynamic length signals that shall be sent via CAN FD it is recommended to use the Multi PDU Mapping feature of the IpduM. This avoids misinterpretation of the received length due to the discrete data lengths of CAN FD frames.

7.6.1 Transmission of Dynamic Length Signals/ I-PDUs

For sending a dynamic length signal, the RTE needs to specify the actual length at the send call. The corresponding API is Com_SendDynSignal (SWS_Com_00627).

[SWS_Com_00757] [At a call to Com_SendDynSignal, the AUTOSAR COM module shall set the length of the corresponding dynamic length I-PDU to the smallest length that includes the dynamic length signal. The length of the dynamic signal shall be equal to the value of input parameter "Length" passed in the API Com_SendDynSignal.] (SRS_Com_02093)

The AUTOSAR COM module is able to send dynamic length I-PDUs via normal or large I-PDUs. In any case, it needs to pass the length of the dynamic I-PDU to the lower layers.

[SWS_Com_00832] [When the AUTOSAR COM module invokes PduR_ComTransmit for a dynamic length I-PDU, the SduLength of the PduInfoType shall be set according the last update (or init value if not yet sent) of the included dynamic length signal.] (SRS_Com_02093)

7.6.2 Reception of Dynamic Length Signals/ I-PDUs

For receiving a dynamic length signal, the RTE needs to be informed about the actual size.

[SWS_Com_00758] [At reception of a dynamic length I-PDU, the AUTOSAR COM module shall calculate the length of the contained dynamic length signal, by:

$$\langle \text{dynamic signal length in bytes} \rangle = \langle \text{received I-PDU length in bytes} \rangle - \langle \text{ComBitPosition of dynamic length signal} \rangle / 8$$
] (SRS_Com_02093)

Com_ReceiveDynSignal (SWS_Com_00690) returns the length of a dynamic length signal, calculated as defined by SWS_Com_00758.

Since, the length of a dynamic length signal is derived from the received length of the I-PDU, the AUTOSAR COM module does not support the combination of dynamic length I-PDUs and I-PDUs with metadata, see SWS_Com_00817.

7.7 Interface between AUTOSAR COM Module and the PDU Router

[17] leaves the interface between COM and the lower layers undefined. In AUTOSAR, the only lower layer that the AUTOSAR COM module interfaces to is the PDU Router.

The AUTOSAR COM module uses the PDU Router in two different modes, depending on the type of the I-PDU it will be transported with the bus-specific transport protocol or without. If an I-PDU is supposed to be sent via TP, is configured per configuration parameter ComIPduType.

[SWS_Com_00138] [The AUTOSAR COM module shall send out I-PDUs by a calling the PduR_ComTransmit function.] (SRS_Com_02037)

[SWS_Com_00759] [If the AUTOSAR COM module sends out an I-PDU with ComIPduType configured to *NORMAL*, the AUTOSAR COM module shall expect to be called by the PDU Router using Com's interfaces for modules that do not use TP. See column *normal I-PDUs* in Table 6.] (SRS_Com_02096)

[SWS_Com_00760] [If the AUTOSAR COM module sends out an I-PDU with ComIPduType configured to *TP*, the AUTOSAR COM module shall expect to be called by the PDU Router using Com's interfaces for modules that use TP. See column *TP I-PDUs* in Table 6.] (SRS_Com_02096)

The interaction diagram in Chapter 9.1 shows the interaction between the PDU Router module and the AUTOSAR COM module for normal I-PDUs.

Table 6 gives an overview, which API between the AUTOSAR COM module and the PDU Router is used for a concrete I-PDU with respect to the configured value of ComIPduType. The API description itself is specified in Chapter 8.

<i>API</i>	<i>normal I-PDUs</i>	<i>TP I-PDUs</i>
PduR_ComTransmit	X	X
Com_TxConfirmation	X	-
Com_RxIndication	X	-
Com_TriggerTransmit	X	-
Com_TpTxConfirmation	-	X
Com_TpRxIndication	-	X
Com_StartOfReception	-	X
Com_CopyRxData	-	X
Com_CopyTxData	-	X

Table 6: API to PDU Router with respect to ComIPduType

7.8 Update-Bits

To enable the receiver of a signal/ signal group to identify whether the sender has updated the data in this signal/ signal group before sending, the AUTOSAR COM module supports *update-bits*.

The update-bits indicate whether the RTE on sender-side has updated a signal value, before the I-PDU, containing that signal, was transmitted to the PDU Router.

Update-bits are not allowed if transmission mode *DIRECT* is used with ComTxMode-NumberOfRepetitions greater or equal 1 (see SWS_Com_00310).

By configuration on sender- and on receiver-side, it is possible to add separately for each signal and/or separately for each signal group at most one update-bit.

The position of the update-bit is configurable by configuration parameter ComUpdateBitPosition (ECUC_Com_00257). ComUpdateBitPosition is included within the configuration container ComSignal. Hence, it is ensured that the signal/ signal group and the corresponding update-bit are always part of the same I-PDU.

[SWS_Com_00055] [The AUTOSAR COM module shall handle the update-bit only internally and not as part of the signal or signal group.] (SRS_Com_02030)

The update-bits are not directly visible or accessible by AUTOSAR Software Components.

[SWS_Com_00059] [The AUTOSAR COM module shall interpret the update-bit as defined in Table 7.] (SRS_BSW_00101, SRS_Com_02030)

<i>Update-BIT</i>	
0	cleared/ data has not been updated
1	set/ data has been updated

Table 7 update-bit interpretation

7.8.1 Sender Side

The initialization of update-bits is defined by SWS_Com_00117.

[SWS_Com_00061] [If the RTE updates the value of a signal by calling Com_SendSignal, the AUTOSAR COM module shall set the update-bit of this signal.] (SRS_Com_02030)

[SWS_Com_00801] [If the RTE updates a signal group by calling Com_SendSignalGroup, the AUTOSAR COM module shall set the update-bit of this signal group.] (SRS_Com_02030)

[SWS_Com_00062] [If the parameter ComTxIPduClearUpdateBit of an I-PDU is configured to *Transmit*, the AUTOSAR COM module shall clear all update-bits of all contained signals and signal groups after this I-PDU was sent out via PduR_ComTransmit and PduR_ComTransmit returned E_OK.] (SRS_Com_02030)

[SWS_Com_00577] [If the parameter ComTxIPduClearUpdateBit of an I-PDU is configured to *Confirmation*, the AUTOSAR COM module shall clear all update-bits of all contained signals and signal groups after this I-PDU was sent out via PduR_ComTransmit, PduR_ComTransmit returned E_OK and the I-PDU was successfully confirmed.] (SRS_Com_02030)

[SWS_Com_00578] [If the parameter ComTxIPduClearUpdateBit of an I-PDU is configured to *TriggerTransmit*, the AUTOSAR COM module shall clear all update-bits of all contained signals and signal groups after the contents of this I-PDU was successfully requested by Com_TriggerTransmit.] (SRS_Com_02030)

7.8.2 Receiver Side

[SWS_Com_00324] [If a signal or signal group with an attached update bit is received, the AUTOSAR COM module shall only process this signal, i.e. filter, notification, signal based gateway, byte swapping, if the signal's update bit is set.] (SRS_Com_02030)

[SWS_Com_00802] [If a signal or signal group with an attached update bit is received and the update-bit is not set, the AUTOSAR COM module shall discard this signal.] (SRS_Com_02030)

If the signal has not been updated, the signal will not be routed via the signal gateway. It will only be discarded.

If the RTE reads a signal with an associated cleared update-bit, the init value or the last received value is returned.

[SWS_Com_00067] [The AUTOSAR COM module shall interpret a signal/ signal group as *updated* if the signal has an update-bit attached, and the value of the update-bit is set.] (SRS_Com_02030)

For the behavior of reception deadline monitoring on signals with update-bits, see Chapter 7.3.6.1.

7.9 Data Sequence Control

The AUTOSAR COM module provides mechanisms of data sequence control in the form of I-PDU Counters. *Out of sequence* I-PDUs, those are repeated I-PDUs or I-PDUs received after missing I-PDUs, will be detected and discarded.

I-PDU counters are optional and can be configured per I-PDU. For the corresponding configuration container see ECUC_Com_00592.

7.9.1 Sender Side

[SWS_Com_00687] [For all I-PDUs with ComIPduDirection configured to *SEND* that have a configured ComIPduCounter, the AUTOSAR COM module shall set the I-PDU counter to 0, after the I-PDU was initialized by Com_Init or reinitialized by Com_IpduGroupStart.] (SRS_Com_02101)

[SWS_Com_00688] [The AUTOSAR COM module shall increase the I-PDU counter of an I-PDU by one, with respect to counter wrap around, directly before the I-PDU is sent out by PduR_ComTransmit. In case the return value of PduR_ComTransmit is not equal to E_OK the update of the I-PDU counter shall be revoked (by decrementing the I-PDU counter by one).] (SRS_Com_02101)

If Com_TriggerTransmit fetches an I-PDU containing an I-PDU counter, no incrementation takes place. Hence, care must be taken if I-PDU counters are used in combination with Com_TriggerTransmit. If Com_TriggerTransmit is called multiple times after the corresponding PduR_ComTransmit all I-PDUs will contain the same counter value. Thus, a deferred TriggerTransmit transmission can work, but a pure lower layer driven TriggerTransmit use-case would not work in combination with an I-PDU counter.

7.9.2 Receiver Side

[SWS_Com_00587] [For all I-PDUs with ComIPduDirection configured to *RECEIVE* that have a configured ComIPduCounter, the AUTOSAR COM module shall accept any incoming I-PDU, regardless of the value of the I-PDU counter, after the I-PDU was initialized by Com_Init or reinitialized by Com_IpduGroupStart.] (SRS_Com_02099)

[SWS_Com_00588] [At reception of an I-PDU containing an I-PDU counter, the AUTOSAR COM module shall set the next expected value to the value following the received value with respect to counter wrap-around.] (SRS_Com_02101)

Example: If the I-PDU counter has 4 bits its possible values are 0 – 15. If an I-PDU with a 4-bit sized counter is received and the received counter value is 15 the next expected value is 0. The new expected value needs to be updated regardless if the received value matches the actual expected value or not.

[SWS_Com_00590] [At reception of an I-PDU containing an I-PDU counter, the AUTOSAR COM module shall discard the I-PDU, after setting the next expected value

as defined in SWS_Com_00588, if no I-PDU replication for this I-PDU is configured and:

received I-PDU counter < expected I-PDU counter OR
 received I-PDU counter > expected I-PDU counter
 + ComIPduCounterThreshold

with respect to counter wrap-around.] (SRS_Com_02102)

[SWS_Com_00727] [In case a mismatch of the expected and the received I-PDU counter is detected, the AUTOSAR COM module shall notify this mismatch by the configured ComIPduCounterErrorNotification (ECUC_Com_00003) notification function.] (SRS_Com_02102)

The counter error notification is triggered independently of the configured ComIPduCounterThreshold.

The signature of this I-PDU counter error notification function is defined in SWS_Com_00726.

Example: In the example in Table 8, the I-PDU counter is 4-bit wide (values 0-15) and ComIPduCounterThreshold is configured to 1:

<i>Expected I-PDU counter</i>	<i>Received counter value</i>	<i>Action</i>
6	6	<i>normal reception</i>
6	7	<i>normal reception</i>
6	8	<i>discarded</i>
6	1	<i>discarded</i>
15	15	<i>normal reception</i>
15	0	<i>normal reception</i>
15	1	<i>discarded</i>

Table 8 Example I-PDU counter handling

7.10 Communication Protection

Safety related I-PDUs might need to be replicated in multiple L-PDUs in order to prevent corruption and loss of data. In AUTOSAR the replication of I-PDUs is realized by the PDU Router. The comparison and voting of replicated I-PDUs is performed in AUTOSAR COM. Since the replicated I-PDUs have no checksum or signature for comparison it is needed to store and compare the complete I-PDUs at the receiver. The AUTOSAR COM allows configuring two additional replicated I-PDUs via ComIPduReplicaRef (ECUC_Com_00601).

The number of successfully equally received I-PDUs needed for a qualified reception can be configured via ComIPduReplicationQuorum (ECUC_Com_00600) from 1 to 3. The PDU Router module does not support 1:n routing of I-PDUs which are sent or received via a TP module and require multiple frames for transmission. Hence, the AUTOSAR COM stack does currently not support replication of large or dynamic I-PDUs or data types.

7.10.1 Sender Side

Since the replication itself is done by the PduR, there is no special handling on sender side for AUTOSAR COM. However, it must be ensured that replicated I-PDUs have configured an I-PDU counter, see SWS_Com_00834. This is required since the voting at the receiver relies on the I-PDU counter.

7.10.2 Receiver Side

At receiver side, the AUTOSAR COM module performs a voting about the multiple replicated I-PDUs. The AUTOSAR COM module passes only signals of successfully confirmed I-PDUs to the RTE. As stated above replicated I-PDUs need to have an I-PDU counter configured. However, the *ComIPduCounterThreshold* must be configured to 0, see ECUC_Com_00595. There is no use-case of mixing these two features and the voting would be more complex.

[SWS_Com_00596] [Only when the AUTOSAR COM module has received at least *ComIPduReplicationQuorum* identical copies of a replicated I-PDU, it shall provide the signals and/ or signal groups out of this I-PDU to the RTE.] (SRS_Com_02103, SRS_Com_02105, SRS_Com_02106)

A replicated I-PDU is configured as a normal I-PDU within the AUTOSAR COM module's configuration. The fan-out on sender-side is configured within the PduR configuration. On reception-side, additionally up to two replicas of PDU-R PDUs (see ECUC_Com_00601 *ComIPduReplicaRef*) and the necessary number of identically received I-PDUs for successfully voting (see ECUC_Com_00600 *ComIPduReplicationQuorum*) can be configured within the AUTOSAR COM module's configuration.

[SWS_Com_00597] [When the AUTOSAR COM module has received at least *ComIPduReplicationQuorum* identical copies of a replicated I-PDU, it shall notify the RTE only once with respect to the signals and/or signal groups out of this I-PDU.] (SRS_Com_02103, SRS_Com_02105, SRS_Com_02106)

The I-PDU counter will be handled for each replicated I-PDU separately as defined in Chapter 7.9.

Since the I-PDUs do not contain a special checksum, it is expected, that the comparison is performed by comparing the complete I-PDU byte by byte.

For I-PDU replication, the *ComIPduCounterThreshold* needs to be configured to 0, see SWS_Com_00834. Hence, *ComIPduReplicaRef* + 1 buffers are sufficient to store the I-PDUs for a successful voting.

7.10.3 Constraints

Due to the approach of reusing already existing functionality, that is using the PduR for the fan out, care must be taken to set up the system correctly. The PduR allows fanning out the replicated I-PDUs on different busses. On the receiver side, these I-PDUs are indicated to COM with the same I-PDU id. However, *Com_RxIndication*

(SWS_Com_00123) may not be called reentrant for the same I-PDU id. An easy way to prevent this is to ensure that all I-PDUs are received by the same Interface module, which results in using the same bus for all replicas. For the current AUTOSAR stack, this is the recommend method. However, the system integrator could also synchronize the reception path by other means.

Furthermore, since there is no mechanism to prevent updates from the upper layer to an I-PDU, this approach of communication protection does not work in combination of decoupled transmission, i.e. I-PDUs requested via Com_TriggerTransmit.

7.11 Signal Gateway

The signal gateway is an integrated part of the AUTOSAR COM module. Any external modules, except the cyclic task call, cannot access the signal gateway.

The AUTOSAR COM module's signal gateway works with signals and signal groups.

The AUTOSAR COM module's signal gateway supports only static routing for the ComGwMapping configuration container (ECUC_Com_00544). It is only possible to configure routes independently of the contents of the routed signals and group signals.

The destination of a signal or group signal can be configured either per ComGwDestinationDescription container (ECUC_Com_00549), or via ComGwSignal reference (ECUC_Com_00551). The transmission mode will be selected based on the TMCs of other associated signals of the I-PDU. In case no signal contributes to the TMS calculation, the transmission mode ComTxModeTrue (SWS_Com_00677) will be used.

[SWS_Com_00377] [The AUTOSAR COM module's signal gateway shall copy the value of routed signals/ group signals to the signals/ group signals for transmission according to configuration, see ECUC_Com_00544.] (SRS_PduR_06055, SRS_PduR_06089)

The ComGwMapping configuration allows to configure routing a signal/ group signal from one source signal/ group signal to zero (no signal gateway functionality) or more destinations (1:n).

The AUTOSAR COM module's signal gateway does not support to process signals or group signals that are contained within a large I-PDU, see SWS_Com_00598.

[SWS_Com_00872] [The Signal Gateway shall support the following I-PDU/ signal-processing stages on the receiver side (see also Figure 5):

- 1) reset reception deadline monitoring timer for I-PDU based monitoring
- 2) I-PDU callout
- 3) check of update-bits
- 4) endianness conversion and sign extension

] (SRS_PduR_06055, SRS_PduR_06089)

[SWS_Com_00873] [The Signal Gateway shall support the following I-PDU/ signal-processing stages on the sender side (see also Figure 5):

- 1) set of update-bits
- 2) endianness conversion and sign extension
- 3) I-PDU transmission mode selection
- 4) I-PDU callout

] (SRS_PduR_06055, SRS_PduR_06089)

7.11.1 Dealing with Signals

[SWS_Com_00357] [The AUTOSAR COM module shall forward signals to be routed from received I-PDUs to transmit I-PDUs. For configuration, see ECUC_Com_00544 configuration container ComGwMapping.] (SRS_PduR_06002)

Stopping the receive I-PDU after the signals to be routed have been forwarded to the transmit I-PDU will not prevent the transmit I-PDU from being transmitted unless it is stopped as well.

[SWS_Com_00360] [If the endianness of a received signal to be routed differs from the endianness of a related destination signal, the AUTOSAR COM module shall convert its endianness to the endianness of the destination signal.] (SRS_PduR_06061)

7.11.2 Dealing with Group Signals

[SWS_Com_00361] [The AUTOSAR COM module shall forward routed group signals from received I-PDUs to transmit I-PDUs. See also configuration container ComGwMapping (ECUC_Com_00544).] (SRS_PduR_06002, SRS_PduR_06056, SRS_PduR_06061)

Stopping the receive I-PDU after the group signals to be routed have been forwarded to the transmit I-PDU will not prevent the transmit I-PDU from being transmitted unless it is stopped as well.

[SWS_Com_00383] [The AUTOSAR COM module shall route all group signals belonging to the same signal group in a consistent manner. Therefore, the AUTOSAR COM module shall transfer the data of a signal group as one consistent (sub-)set of data during a routing operation.] (SRS_PduR_06056)

[SWS_Com_00735] [The AUTOSAR COM module shall support routing consistently a subset of group signals of a source signal group into a reduced target signal group.] (SRS_PduR_06056)

[SWS_Com_00833] [The AUTOSAR COM module shall support routing of individual group signals of a source signal group to a individual target signals (which are not part of signal group).] (SRS_PduR_06056)

[SWS_Com_00362] [If the endianness of a received group signal to be routed differs from the endianness of a related destination (group) signal, the AUTOSAR COM

module shall convert its endianness to the endianness of the destination (group) signal.] (SRS_PduR_06061)

7.11.3 Routing of Out-Timed Signals and Signal Groups

[SWS_Com_00701] [The AUTOSAR COM module's signal gateway shall route signal and group signals even if any configured reception deadline monitoring timeout expired.] (SRS_PduR_06089)

In case of a not in time received signal or group signal the AUTOSAR COM module's signal gateway will route these signal or group signal anyway.

7.11.4 Handling of Update-Bits

The routing relations for signal groups are solely defined on the group signals. However, with respect to the update-bit the integrated signal gateway has to respect the update-bits of the enclosing signal groups. Hence, when update-bits of signal groups are referenced within this chapter the signal groups that include the configured group signals are meant.

[SWS_Com_00702] [If both, the received signal/ signal group and the destination signal/ signal group have an update-bit (ComUpdateBitPosition) configured and the update-bit of the received signal/ signal group is set, the AUTOSAR COM module shall route the signal/ signal group with the set update-bit and clear the update-bit of the destination signal/ signal group after it was sent.] (SRS_Com_02030)

[SWS_Com_00703] [If the received signal/ signal group and the destination signal/ signal group have an update-bit (ComUpdateBitPosition) configured, and the update-bit of the received signal/ signal group is not set, the AUTOSAR COM module shall not route this signal/ signal group.] (SRS_Com_02030)

[SWS_Com_00704] [If the received signal/ signal group has an update-bit (ComUpdateBitPosition) configured, but the destination signal has no update-bit configured, and the update-bit is set, the AUTOSAR COM module shall route this signal/ signal group without the update-bit.] (SRS_Com_02030)

[SWS_Com_00705] [If the received signal/ signal group has an update-bit (ComUpdateBitPosition) configured, but the destination signal has no update-bit configured, and the update-bit is not set, the AUTOSAR COM module shall not route this signal/ signal group.] (SRS_Com_02030)

[SWS_Com_00706] [If the received signal/ signal group has no update-bit (ComUpdateBitPosition) configured and the destination signal/ signal group has an update-bit configured, the AUTOSAR COM module shall set the update-bit of the destination signal when a new signal/ signal group was received and clear it after sending of the destination signal/ signal group.] (SRS_Com_02030)

7.11.5 Decoupling Signal Gateway

To protect interrupt routines used for I-PDU reception from incalculable and perhaps expensive time usage, it is necessary to decouple the AUTOSAR COM module's signal gateway from interrupt routines.

[SWS_Com_00359] [The AUTOSAR COM module shall execute all functions of its signal gateway during the function call `Com_MainFunctionRouteSignals` (SWS_Com_00400). During this function call, the AUTOSAR COM module's signal gateway shall check received routed signals and group signals and copy them from the related receive I-PDUs to the related transmit I-PDUs.] (SRS_BSW_00425, SRS_BSW_00432)

[SWS_Com_00466] [Within `Com_MainFunctionRouteSignals`, the AUTOSAR COM module shall evaluate the transfer properties and transmission modes and perform its routing actions in the following sequence, see also Figure 2:

1. copy all gated signals from the source to the target I-PDUs
2. evaluate the TMC of all gated signals
3. evaluate the TMS for the target I-PDUs

] (SRS_BSW_00432)

In the case, that a target I-PDU contains gated signals with `ComTransferProperty` `TRIGGERED` that are newly received, the sending may be performed in either `Com_MainFunctionTx` or `Com_MainFunctionRouteSignals`.

[SWS_Com_00539] [The AUTOSAR COM module shall sent out an I-PDU at most once while one call to `Com_MainFunctionRouteSignals`.] (SRS_PduR_06055)

7.12 Error Classification

7.12.1 Development Errors

[SWS_Com_00803] [API service called with wrong parameter:

- error code: `COM_E_PARAM`
- value [hex]: `0x01`

] (SRS_BSW_00337)

[SWS_Com_00804] [Error code if any API service (except `Com_GetStatus`, `Com_GetVersionInfo`, `Com_MainFunctionRx`, `Com_MainFunctionTx` and `Com_MainFunctionRouteSignals`) is called before the AUTOSAR COM module was initialized with `Com_Init` or after a call to `Com_DeInit`:

- error code: `COM_E_UNINIT`
- value [hex]: `0x02`

] (SRS_BSW_00337)

[SWS_Com_00805] [NULL pointer checking:

- error code: COM_E_PARAM_POINTER
 - value [hex]: 0x03
-] (SRS_BSW_00414)

[SWS_Com_00837] [Invalid configuration set selection:

- error code: COM_E_INIT_FAILED
 - value [hex]: 0x04
-] (SRS_BSW_00414)

7.12.2 Runtime Errors

[SWS_Com_00864] [Transmission request was skipped:

- error code: COM_E_SKIPPED_TRANSMISSION
 - value [hex]: 0x05
-] (SRS_BSW_00452)

7.12.3 Transient Faults

There are no transient faults.

7.12.4 Production Errors

There are no production errors.

7.12.5 Extended Production Errors

There are no extended production errors.

7.13 Error Notification

[SWS_Com_00442] [When a development error is detected, the function Det_ReportError of the Default Error Tracer shall be called with:

- 50 as the AUTOSAR COM's ModuleId
- 0 as InstanceId
- the service ID of the AUTOSAR COM module's API in which the error was detected as ApId
- the error ID as defined in Chapter 7.12.1 as ErrorId

] (SRS_BSW_00369, SRS_BSW_00385, SRS_BSW_00327, SRS_PduR_06098, SRS_PduR_06099)

7.14 Error Handling

AUTOSAR COM supports supervision of the communication with deadline monitoring, see Chapter 7.3.6. Further, the AUTOSAR COM supports data sequence control see Chapter 7.9 and communication protection see Chapter 7.10.

The concrete reaction of the AUTOSAR COM module with respect to error and return values of called APIs is stated within the corresponding functional requirements.

7.15 AUTOSAR COM Module's Interaction Model

This chapter corresponds to the chapter *Functional Model of Interaction Layer* of [17]. The following figures illustrate the behavior of the Interaction layer for external reception and external transmission. The complete functionality is shown but it depends on the configuration what parts are present/ used in a concrete implementation.

[SWS_Com_00396] [A received signal or signal group can be configured for various processing steps. The AUTOSAR COM module shall execute the configured processing steps in the following order:

- 1) reset reception deadline monitoring timer for I-PDU based monitoring
- 2) check update-bits
- 3) endianness conversion and sign extension
- 4) data invalidation
- 5) reception filtering
- 6) reset reception deadline monitoring timer for signal based monitoring
- 7) notification

] (SRS_Com_02037)

[SWS_Com_00744] [In case both a ComRxDataTimeoutAction and a ComTimeoutNotification is configured for a ComSignal or a ComSignalGroup, the AUTOSAR COM module shall first call the configured ComRxDataTimeoutAction and then call the configured ComTimeoutNotification.] (SRS_Com_02089)

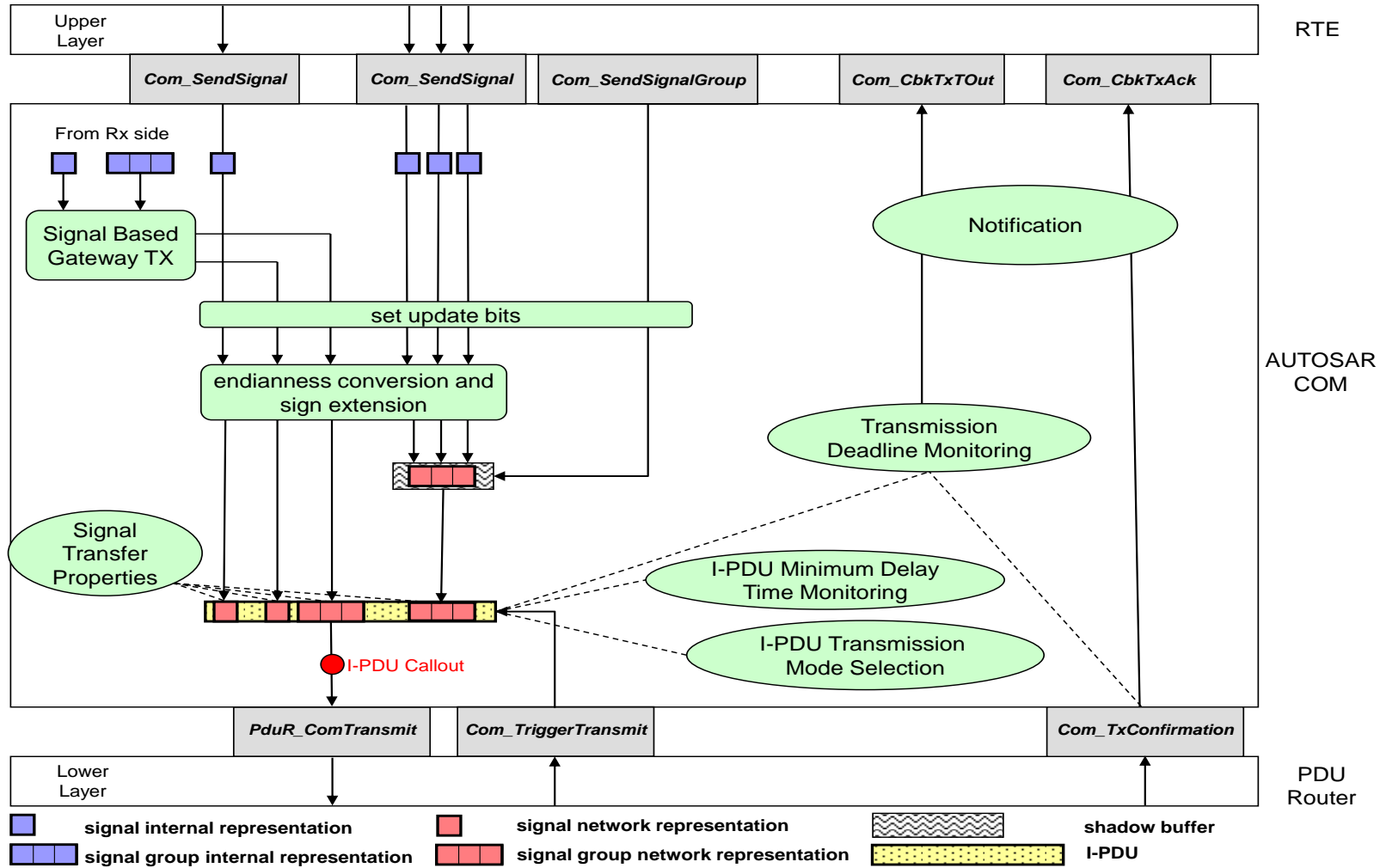

Figure 3 The AUTOSAR COM module's interaction model for transmission

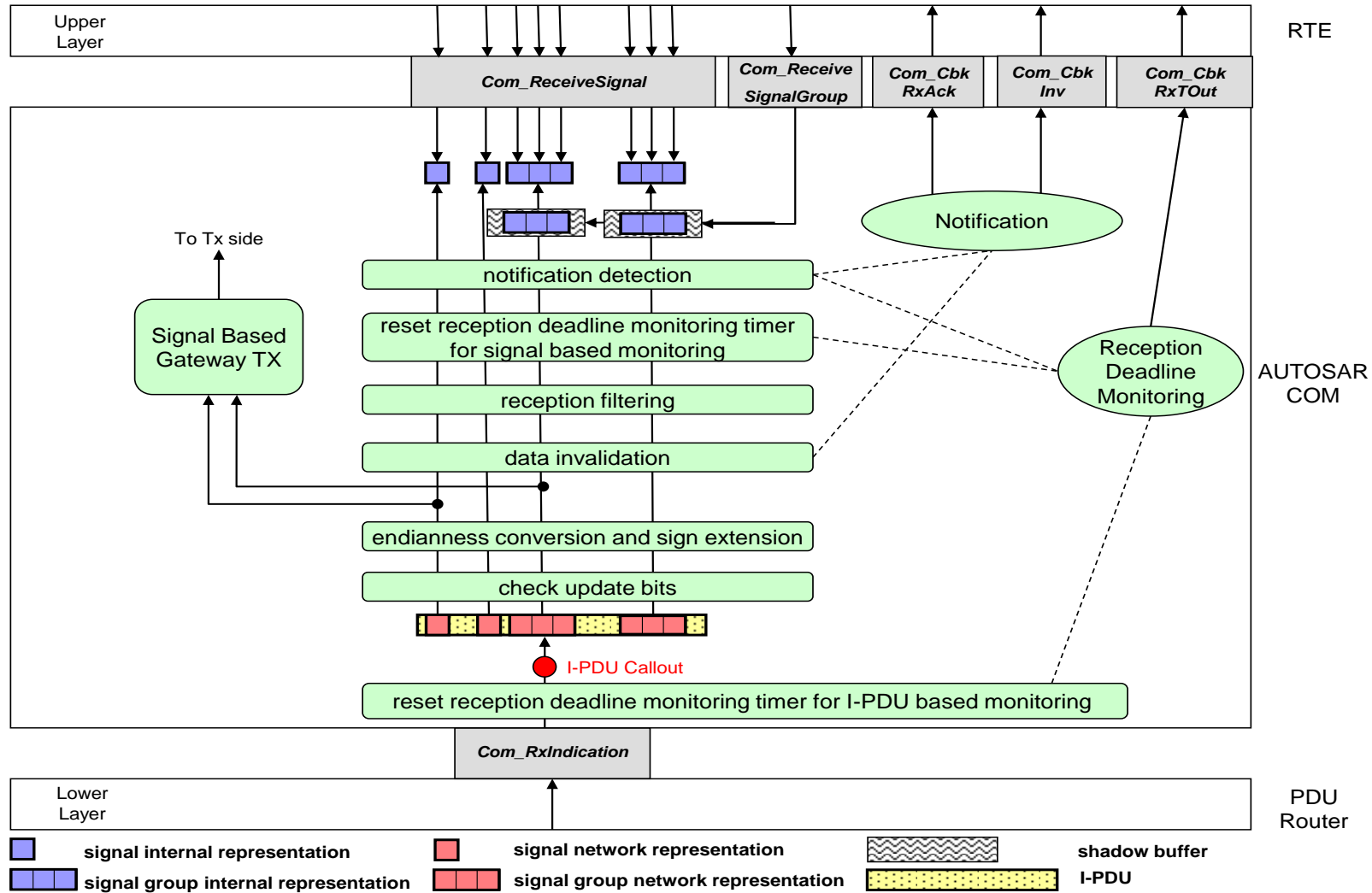

Figure 4 The AUTOSAR COM module's interaction model for reception

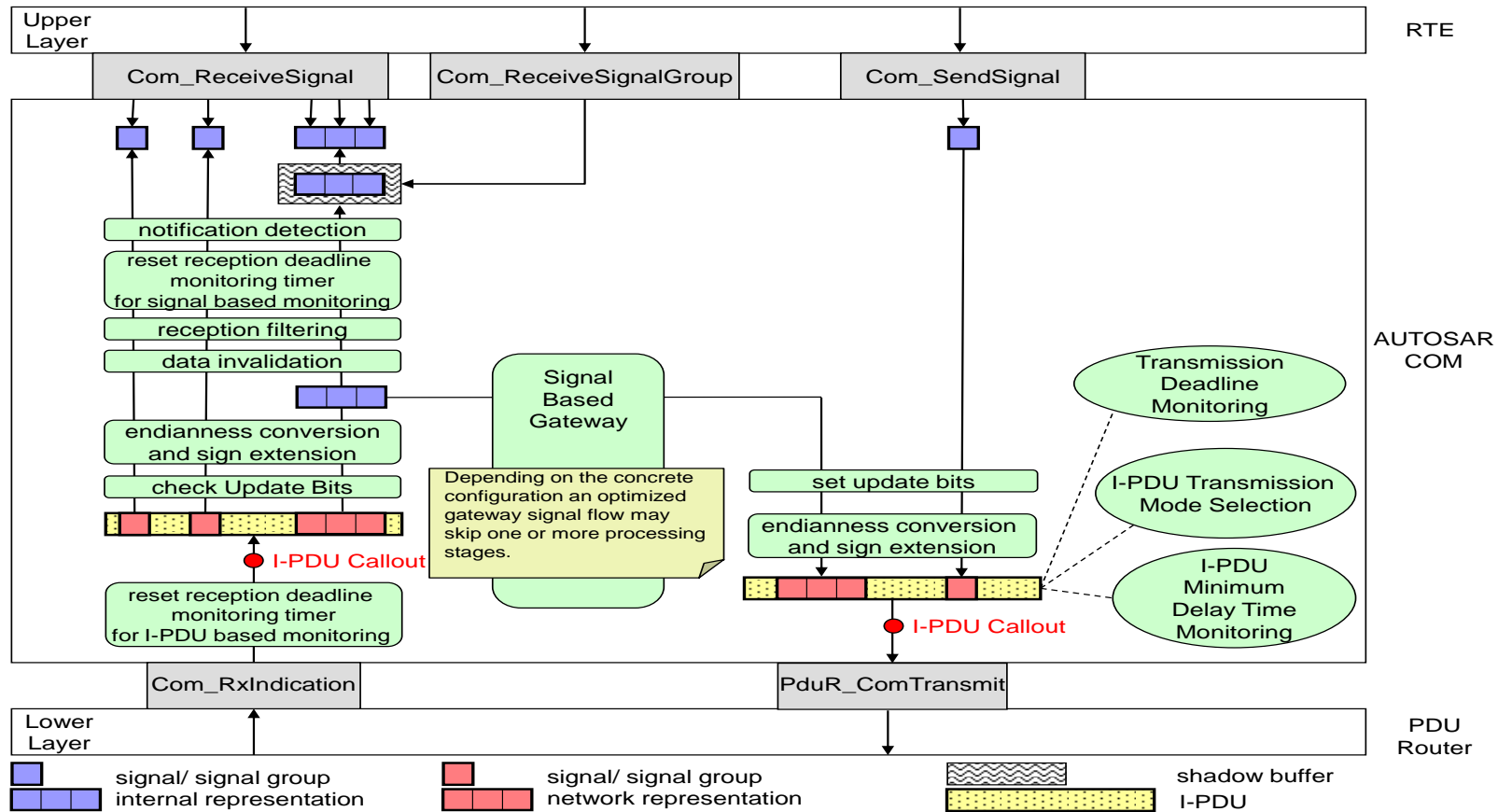

Figure 5: The AUTOSAR COM module's interaction model for integrated Signal Gateway

The endianness conversion and sign extension on receiver side are needed to feed the TMS with a correct data format. This endianness conversion is only necessary if the endianness of the Rx-bus differs from the endianness of the CPU. The endianness conversion on the sender side is only necessary if the endianness of the Rx-bus differs from the endianness of the Tx-bus.

8 API Specification

8.1 Imported Types

In this chapter, all types included from the following files are listed:

[SWS_Com_00609] [

Module	Header File	Imported Type
ComStack_Types	ComStackTypes.h	BufReq_ReturnType
	ComStackTypes.h	PduIdType
	ComStackTypes.h	PduInfoType
	ComStackTypes.h	PduLengthType
	ComStackTypes.h	RetryInfoType
Std_Types	StandardTypes.h	Std_ReturnType
	StandardTypes.h	Std_VersionInfoType

] (SRS_BSW_00301)

8.2 Type Definitions

8.2.1 Com_StatusType

[SWS_Com_00819] [

Name:	Com_StatusType		
Type:	Enumeration		
Range:	COM_INIT	--	The AUTOSAR COM module is initialized and usable.
	COM_UNINIT	0x00	The AUTOSAR COM module is not initialized or not usable. This shall be the default value after reset. This status shall have the value 0.
Description:	This is a status value returned by the API service Com_GetStatus().		
Available via:	Com.h		

] (SRS_BSW_00335)

8.2.2 Com_SignalIdType

[SWS_Com_00820] [

Name:	Com_SignalIdType		
Type:	uint16		
Range:	0..<SignalIdmax>	--	Zero-based integer number
Description:	The AUTOSAR COM module's signal object identifier.		
Available via:	Com.h		

] (SRS_Com_02037, SRS_BSW_00441)

8.2.3 Com_SignalGroupIdType

[SWS_Com_00821] [

Name:	Com_SignalGroupIdType
Type:	uint16
Range:	0..<SignalGroupIdmax>-- Zero-based integer number
Description:	The AUTOSAR COM module's signal group object identifier.
Available via:	Com.h

] (SRS_Com_02041, SRS_BSW_00441)

8.2.4 Com_IpduGroupIdType

[SWS_Com_00822] [

Name:	Com_IpduGroupIdType
Type:	uint16
Range:	0..<IpduGroupId-max>-- Zero-based integer number; where IpduGroupId-max < ComSupportedIPduGroups
Description:	The AUTOSAR COM I-PDU module's group object identifier.
Available via:	Com.h

] (SRS_Com_00218, SRS_BSW_00441)

8.2.5 Com_ConfigType

[SWS_Com_00825] [

Name:	Com_ConfigType
Type:	Structure
Range:	implementation specific The content of the initialization data structure is implementation specific
Description:	This is the type of the data structure containing the initialization data for COM.
Available via:	Com.h

] (SRS_BSW_00404, SRS_BSW_00441)

8.3 Function Definitions

[SWS_Com_00321] [Non-reentrant functions do not have to check if they are called reentrant.] (SRS_BSW_00312)

Most of the COM functions are non-reentrant with respect to a concrete object. E.g. Com_SendSignal is not reentrant for the same signal, but reentrant for different signals. Hence, if there are multiple callers of the AUTOSAR COM module they need to be synchronized on a system level, for example by using disjoint sets of signals and I-PDU groups.

8.3.1 Return Codes

The AUTOSAR COM module does not define a special COM return type. The API services return errors either by using the Std_ReturnType as defined in [5] or via a uint8 value mapped according to Table 9.

Return codes of the AUTOSAR COM module are defined in Table 9.

[SWS_Com_00865]

Name	Description	Type	Value	Defined in
E_OK	the service has been accepted	#define	0x00	StandardTypes.h
E_NOT_OK	invocation of service failed	#define	0x01	StandardTypes.h
COM_SERVICE_NOT_AVAILABLE	the service is currently not available e.g. the corresponding I-PDU group is stopped (or a development error has been detected)	#define	0x80	Com.h
COM_BUSY	Successful execution of this function is currently not possible, because a resource is currently in use. For example, the buffer of a large I-PDU is locked. COM_BUSY might, but must not, be returned whenever a signal of a large I-PDU is accessed.	#define	0x81	Com.h

] (SRS_BSW_00348, SRS_BSW_00377, SRS_BSW_00441)

Table 9: Mapping of AUTOSAR COM module's return codes

8.3.2 Start-Up and Control Services

8.3.2.1 Com_Init

[SWS_Com_00432]

Service name:	Com_Init
Syntax:	void Com_Init(const Com_ConfigType* config)
Service ID[hex]:	0x01
Sync/Async:	Synchronous
Reentrancy:	Non Reentrant
Parameters (in):	config Pointer to the AUTOSAR COM module's configuration data.
Parameters (in-out):	None
Parameters (out):	None
Return value:	None
Description:	This service initializes internal and external interfaces and variables of the AUTOSAR COM module layer for the further processing. After calling this function the inter-ECU communication is still disabled.
Available via:	Com.h

] (SRS_BSW_00344, SRS_BSW_00404, SRS_BSW_00405, SRS_BSW_00101, SRS_BSW_00358, SRS_BSW_00414)

The behavior of the AUTOSAR COM module is unspecified until a correct call to Com_Init is made.

Caveats of Com_Init: It is not foreseen that Com_Init pre-empts any other AUTOSAR COM module's function. The AUTOSAR COM module can rely on the rest of the system that Com_Init is not called in such a way.

8.3.2.2 Com_Delnit

[SWS_Com_00130] [

Service name:	Com_Delnit
Syntax:	void Com_Delnit(void)
Service ID[hex]:	0x02
Sync/Async:	Synchronous
Reentrancy:	Non Reentrant
Parameters (in):	None
Parameters (in-out):	None
Parameters (out):	None
Return value:	None
Description:	This service stops the inter-ECU communication. All started I-PDU groups are stopped and have to be started again, if needed, after Com_Init is called. By a call to Com_Delnit the AUTOSAR COM module is put into an not initialized state.
Available via:	Com.h

] (SRS_BSW_00336)

[SWS_Com_00129] [The AUTOSAR COM module's function Com_Delnit shall stop all started I-PDU groups.] (SRS_BSW_00336)

Caveats of Com_Delnit: It is not foreseen that Com_Delnit pre-empts any AUTOSAR COM module's function. The AUTOSAR COM module can relies on the rest of the system that Com_Delnit is not called in such a way.

8.3.2.3 Com_IpduGroupStart

[SWS_Com_91001] [

Service name:	Com_IpduGroupStart	
Syntax:	void Com_IpduGroupStart(Com_IpduGroupIdType IpduGroupId, boolean initialize)	
Service ID[hex]:	0x03	
Sync/Async:	Synchronous	
Reentrancy:	Reentrant for different I-PDU groups. Non reentrant for the same I-PDU group.	
Parameters (in):	IpduGroupId	Id of I-PDU group to be started
	initialize	flag to request initialization of the data in the I-PDUs of this I-PDU group
Parameters (in-out):	None	
Parameters (out):	None	
Return value:	None	
Description:	Starts a preconfigured I-PDU group. For example, cyclic I-PDUs will be sent out cyclically after the call of Com_IpduGroupStart(). If Initialize is true all I-PDUs of the I-PDU group shall be (re-)initialized before the I-PDU group is started. That is they shall behave like after a start-up of COM, for example the old_value of the filter objects and shadow buffers of signal groups have to be (re-)initialized.	
Available via:	Com.h	

] (SRS_Com_00218)

8.3.2.4 Com_IpduGroupStop

[SWS_Com_91002] [

Service name:	Com_IpduGroupStop
Syntax:	void Com_IpduGroupStop(Com_IpduGroupIdType IpduGroupId)
Service ID[hex]:	0x04
Sync/Async:	Synchronous
Reentrancy:	Reentrant for different I-PDU groups. Non reentrant for the same I-PDU group.
Parameters (in):	IpduGroupId Id of I-PDU group to be stopped
Parameters (in-out):	None
Parameters (out):	None
Return value:	None
Description:	Stops a preconfigured I-PDU group. For example, cyclic I-PDUs will be stopped after the call of Com_IpduGroupStop().
Available via:	Com.h

] (SRS_Com_00218)

8.3.2.5 Com_EnableReceptionDM

[SWS_Com_91004] [

Service name:	Com_EnableReceptionDM
Syntax:	void Com_EnableReceptionDM(Com_IpduGroupIdType IpduGroupId)
Service ID[hex]:	0x06
Sync/Async:	Synchronous
Reentrancy:	Reentrant for different I-PDU groups. Non reentrant for the same I-PDU group.
Parameters (in):	IpduGroupId Id of I-PDU group where reception DM shall be enabled.
Parameters (in-out):	None
Parameters (out):	None
Return value:	None
Description:	Enables the reception deadline monitoring for the I-PDUs within the given I-PDU group.
Available via:	Com.h

] (SRS_Com_00192)

8.3.2.6 Com_DisableReceptionDM

[SWS_Com_91003] [

Service name:	Com_DisableReceptionDM
Syntax:	void Com_DisableReceptionDM(Com_IpduGroupIdType IpduGroupId)
Service ID[hex]:	0x05

Sync/Async:	Synchronous
Reentrancy:	Reentrant for different I-PDU groups. Non reentrant for the same I-PDU group.
Parameters (in):	IpduGroupId Id of I-PDU group where reception DM shall be disabled.
Parameters (in-out):	None
Parameters (out):	None
Return value:	None
Description:	Disables the reception deadline monitoring for the I-PDUs within the given I-PDU group.
Available via:	Com.h

] (SRS_Com_00192)

8.3.2.7 Com_GetStatus

[SWS_Com_00194] [

Service name:	Com_GetStatus
Syntax:	Com_StatusType Com_GetStatus(void)
Service ID[hex]:	0x07
Sync/Async:	Synchronous
Reentrancy:	Reentrant
Parameters (in):	None
Parameters (in-out):	None
Parameters (out):	None
Return value:	Com_StatusType COM_UNINIT: the AUTOSAR COM module is not initialized and not usable COM_INIT: the AUTOSAR COM module is initialized and usable
Description:	Returns the status of the AUTOSAR COM module.
Available via:	Com.h

] (SRS_BSW_00331)

8.3.2.8 Com_GetVersionInfo

[SWS_Com_00426] [

Service name:	Com_GetVersionInfo
Syntax:	void Com_GetVersionInfo(Std_VersionInfoType* versioninfo)
Service ID[hex]:	0x09
Sync/Async:	Synchronous
Reentrancy:	Reentrant
Parameters (in):	None
Parameters (in-out):	None
Parameters (out):	versioninfo Pointer to where to store the version information of this module.
Return value:	None
Description:	Returns the version information of this module.
Available via:	Com.h

] (SRS_BSW_00407, SRS_BSW_00003)

For configuration of Com_GetVersionInfo see SWS_Com_00026.

8.3.3 Communication Services

8.3.3.1 Com_SendSignal

[SWS_Com_00197] [

Service name:	Com_SendSignal	
Syntax:	uint8 Com_SendSignal(Com_SignalIdType SignalId, const void* SignalDataPtr)	
Service ID[hex]:	0x0a	
Sync/Async:	Asynchronous	
Reentrancy:	Non Reentrant for the same signal. Reentrant for different signals.	
Parameters (in):	SignalId	Id of signal to be sent.
	SignalDataPtr	Reference to the signal data to be transmitted.
Parameters (in-out):	None	
Parameters (out):	None	
Return value:	uint8	E_OK: service has been accepted COM_SERVICE_NOT_AVAILABLE: corresponding I-PDU group was stopped (or service failed due to development error) COM_BUSY: in case the TP-Buffer is locked for large data types handling
Description:	The service Com_SendSignal updates the signal object identified by SignalId with the signal referenced by the SignalDataPtr parameter.	
Available via:	Com.h	

] (SRS_Com_02037)

[SWS_Com_00624] [The service Com_SendSignal shall update the signal object identified by SignalId with the signal referenced by the SignalDataPtr parameter.] (SRS_Com_02037)

[SWS_Com_00625] [If the updated signal has the ComTransferProperty TRIGGERED and it is assigned to an I-PDU with ComTxModeMode DIRECT or MIXED, then Com_SendSignal shall perform an immediate transmission (within the next main function at the latest) of that I-PDU, unless the sending is delayed or prevented by other COM mechanisms.] (SRS_Com_02037)

A related mechanism is for example the minimum delay timer (ComMinimum-DelayTime).

8.3.3.2 Com_SendDynSignal

[SWS_Com_00627] [

Service name:	Com_SendDynSignal	
Syntax:	uint8 Com_SendDynSignal(Com_SignalIdType SignalId, const void* SignalDataPtr, uint16 Length	

)
Service ID[hex]:	0x21
Sync/Async:	Asynchronous
Reentrancy:	Non Reentrant for the same signal. Reentrant for different signals.
Parameters (in):	SignalId Id of signal to be sent.
	SignalDataPtr Reference to the signal data to be transmitted.
	Length Length of the dynamic length signal
Parameters (in-out):	None
Parameters (out):	None
Return value:	uint8 E_OK: service has been accepted E_NOT_OK: in case the Length is greater than the configured ComSignalLength of this sent signal COM_SERVICE_NOT_AVAILABLE: corresponding I-PDU group was stopped (or service failed due to development error) COM_BUSY: in case the TP-Buffer is locked
Description:	The service Com_SendDynSignal updates the signal object identified by SignalId with the signal referenced by the SignalDataPtr parameter.
Available via:	Com.h

] (SRS_Com_02095)

[SWS_Com_00628] [The service Com_SendDynSignal shall update the signal object identified by SignalId with the signal referenced by the SignalDataPtr parameter.] (SRS_Com_02095)

[SWS_Com_00629] [If the updated signal (see SWS_Com_00628) has the ComTransferProperty *TRIGGERED*, then the function Com_SendDynSignal shall perform an immediate transmission (within the next main function at the latest) of the I-PDU associated with the signal except when the signal is packed into an I-PDU with Periodic transmission mode.] (SRS_Com_02095)

[SWS_Com_00630] [If the updated signal, see SWS_Com_00628, has the ComTransferProperty *PENDING*, then the function Com_SendDynSignal shall not perform a transmission of the I-PDU associated with the signal.] (SRS_Com_02095)

There is no restriction regarding the minimal length of a dynamic length signal. Hence, it is allowed that a dynamic length signal has zero length.

8.3.3.3 Com_ReceiveSignal

[SWS_Com_00198] [

Service name:	Com_ReceiveSignal
Syntax:	uint8 Com_ReceiveSignal(Com_SignalIdType SignalId, void* SignalDataPtr)
Service ID[hex]:	0x0b
Sync/Async:	Synchronous
Reentrancy:	Non Reentrant for the same signal. Reentrant for different signals.
Parameters (in):	SignalId Id of signal to be received.
Parameters (in-out):	None

Parameters (out):	SignalDataPtr	Reference to the location where the received signal data shall be stored
Return value:	uint8	E_OK: service has been accepted COM_SERVICE_NOT_AVAILABLE: corresponding I-PDU group was stopped (or service failed due to development error) COM_BUSY: in case the TP-Buffer is locked for large data types handling
Description:	Com_ReceiveSignal copies the data of the signal identified by SignalId to the location specified by SignalDataPtr.	
Available via:	Com.h	

] (SRS_Com_02037)

[SWS_Com_00631] [The service Com_ReceiveSignal shall copy the data of the signal object identified by SignalId to the position referenced by SignalDataPtr.] (SRS_Com_02037)

Caveats of Com_ReceiveSignal: The AUTOSAR COM module relies on the fact the SignalDataPtr is properly aligned with respect to the data type of the signal with the given SignalId. The caller of Com_ReceiveSignal has to ensure this.

8.3.3.4 Com_ReceiveDynSignal

[SWS_Com_00690] [

Service name:	Com_ReceiveDynSignal	
Syntax:	uint8 Com_ReceiveDynSignal(Com_SignalIdType SignalId, void* SignalDataPtr, uint16* Length)	
Service ID[hex]:	0x22	
Sync/Async:	Synchronous	
Reentrancy:	Non Reentrant for the same signal. Reentrant for different signals.	
Parameters (in):	SignalId	Id of signal to be received.
Parameters (in-out):	Length	in: maximum length that could be received out: length of the dynamic length signal
Parameters (out):	SignalDataPtr	reference to the location where the received signal data shall be stored
Return value:	uint8	E_OK: service has been accepted E_NOT_OK: in case the Length (as in-parameter) is smaller than the received length of the dynamic length signal COM_SERVICE_NOT_AVAILABLE: corresponding I-PDU group was stopped (or service failed due to development error) COM_BUSY: in case the TP-Buffer is locked
Description:	Com_ReceiveDynSignal copies the data of the signal identified by SignalId to the location specified by SignalDataPtr and stores the length of the dynamical length signal at the position given by the Length parameter.	
Available via:	Com.h	

] (SRS_Com_02092, SRS_Com_02095)

[SWS_Com_00711] [The service Com_ReceiveDynSignal shall copy the data of the signal object identified by SignalId to the position referenced by SignalDataPtr.] (SRS_Com_02092)

[SWS_Com_00712] [The service Com_ReceiveDynSignal shall return the calculated length (see SWS_Com_00758) of the dynamic length signal identified by SignalId in parameter Length.] (SRS_Com_02092)

[SWS_Com_00724] [In case, the Length (as in-parameter) is smaller than the received length of the dynamic length signal, Com_ReceiveDynSignal shall not copy any data to the position referenced by SignalDataPtr.] (SRS_Com_02092)

8.3.3.5 Com_SendSignalGroup

[SWS_Com_00200] [

Service name:	Com_SendSignalGroup	
Syntax:	uint8 Com_SendSignalGroup(Com_SignalGroupIdType SignalGroupId)	
Service ID[hex]:	0x0d	
Sync/Async:	Asynchronous	
Reentrancy:	Non Reentrant for the same group signal. Reentrant for different group signals.	
Parameters (in):	SignalGroupId Id of signal group to be sent.	
Parameters (in-out):	None	
Parameters (out):	None	
Return value:	uint8	E_OK: service has been accepted COM_SERVICE_NOT_AVAILABLE: corresponding I-PDU group was stopped (or service failed due to development error) COM_BUSY: in case the TP-Buffer is locked for large data types handling
Description:	The service Com_SendSignalGroup copies the content of the associated shadow buffer to the associated I-PDU.	
Available via:	Com.h	

] (SRS_Com_02041)

[SWS_Com_00635] [The service Com_SendSignalGroup shall copy the content of the shadow buffer referenced by parameter SignalGroupId to the associated I-PDU.] (SRS_Com_02041)

[SWS_Com_00637] [Configuration of Com_SendSignalGroup: A signal group must be configured before this call. See ECUC_Com_00345 for details.] (SRS_Com_02041)

8.3.3.6 Com_ReceiveSignalGroup

[SWS_Com_00201] [

Service name:	Com_ReceiveSignalGroup	
Syntax:	uint8 Com_ReceiveSignalGroup(Com_SignalGroupIdType SignalGroupId)	
Service ID[hex]:	0x0e	
Sync/Async:	Synchronous	
Reentrancy:	Non Reentrant for the same group signal. Reentrant for different group signals.	
Parameters (in):	SignalGroupId Id of signal group to be received.	

Parameters (in-out):	None	
Parameters (out):	None	
Return value:	uint8	E_OK: service has been accepted COM_SERVICE_NOT_AVAILABLE: corresponding I-PDU group was stopped (or service failed due to development error) COM_BUSY: in case the TP-Buffer is locked for large data types handling
Description:	The service Com_ReceiveSignalGroup copies the received signal group from the I-PDU to the shadow buffer.	
Available via:	Com.h	

] (SRS_Com_02041)

[SWS_Com_00638] [The service Com_ReceiveSignalGroup shall copy the received signal group from the I-PDU to the shadow buffer.] (SRS_Com_02041)

After this call, the group signals could be copied from the shadow buffer to the RTE by calling Com_ReceiveSignal.

[SWS_Com_00639] [Configuration of Com_ReceiveSignalGroup: A signal group must be configured before this call. See ECUC_Com_00345 for details.] (SRS_Com_02041)

[SWS_Com_00461] [The AUTOSAR COM module shall always copy the last known data, or the ComSignalInitValue(s) if not yet written, of the I-PDU to the shadow buffer by a call to Com_ReceiveSignalGroup even if the I-PDU is stopped and COM_SERVICE_NOT_AVAILABLE is returned.] (SRS_Com_02041)

8.3.3.7 Com_SendSignalGroupArray

[SWS_Com_00851] [

Service name:	Com_SendSignalGroupArray	
Syntax:	uint8 Com_SendSignalGroupArray(Com_SignalGroupType SignalGroupId, const uint8* SignalGroupArrayPtr)	
Service ID[hex]:	0x23	
Sync/Async:	Asynchronous	
Reentrancy:	Non Reentrant for the same signal group. Reentrant for different signal groups.	
Parameters (in):	SignalGroupId	Id of signal group to be sent.
	SignalGroupArrayPtr	Reference to the signal group array.
Parameters (in-out):	None	
Parameters (out):	None	
Return value:	uint8	E_OK: service has been accepted COM_SERVICE_NOT_AVAILABLE: corresponding I-PDU group was stopped (or service failed due to development error) COM_BUSY: in case the TP-Buffer is locked for large data types handling
Description:	The service Com_SendSignalGroupArray copies the content of the provided SignalGroupArrayPtr to the associated I-PDU. The provided data shall correspond to the array representation of the signal group.	

Available via:	Com.h
-----------------------	-------

] (SRS_Com_02112, SRS_Com_02041)

[SWS_Com_00852] [The service Com_SendSignalGroupArray shall copy the content designated by the SignalGroupArrayPtr to the associated I-PDU.] (SRS_Com_02112, SRS_Com_02041)

[SWS_Com_00853] [The Com_SendSignalGroupArray API shall only be available when the configuration switch ComEnableSignalGroupArrayApi is enabled.] (SRS_Com_00177)

8.3.3.8 Com_ReceiveSignalGroupArray

[SWS_Com_00854] [

Service name:	Com_ReceiveSignalGroupArray	
Syntax:	uint8 Com_ReceiveSignalGroupArray(Com_SignalGroupIdType SignalGroupId, uint8* SignalGroupArrayPtr)	
Service ID[hex]:	0x24	
Sync/Async:	Synchronous	
Reentrancy:	Non Reentrant for the same signal group. Reentrant for different signal groups.	
Parameters (in):	SignalGroupId	Id of signal group to be received.
Parameters (in-out):	None	
Parameters (out):	SignalGroupArrayPtr	reference to the location where the received signal group array shall be stored
Return value:	uint8	E_OK: service has been accepted COM_SERVICE_NOT_AVAILABLE: corresponding I-PDU group was stopped (or service failed due to development error) COM_BUSY: in case the TP-Buffer is locked for large data types handling
Description:	The service Com_ReceiveSignalGroupArray copies the received signal group array representation from the PDU to the location designated by SignalGroupArrayPtr.	
Available via:	Com.h	

] (SRS_Com_02112, SRS_Com_02041)

[SWS_Com_00855] [The service Com_ReceiveSignalGroupArray shall copy the array representation of the received signal group from the I-PDU to the location designated by SignalGroupArrayPtr.] (SRS_Com_02112, SRS_Com_02041)

[SWS_Com_00856] [The Com_ReceiveSignalGroupArray API shall only be available when the configuration switch ComEnableSignalGroupArrayApi is enabled.] (SRS_Com_00177)

[SWS_Com_00857] [The AUTOSAR COM module shall always copy the last known data, or the ComSignalInitValues if not yet written, of the I-PDU to the SignalGroupArrayPtr by a call to Com_ReceiveSignalGroupArray even if the I-PDU is stopped and COM_SERVICE_NOT_AVAILABLE is returned.] (SRS_Com_02041)

8.3.3.9 Com_InvalidateSignal

[SWS_Com_00203] [

Service name:	Com_InvalidateSignal	
Syntax:	uint8 Com_InvalidateSignal(Com_SignalIdType SignalId)	
Service ID[hex]:	0x10	
Sync/Async:	Asynchronous	
Reentrancy:	Non Reentrant for the same signal. Reentrant for different signals.	
Parameters (in):	SignalId Id of signal to be invalidated.	
Parameters (in-out):	None	
Parameters (out):	None	
Return value:	uint8	E_OK: service has been accepted COM_SERVICE_NOT_AVAILABLE: corresponding I-PDU group is stopped, no ComSignalDataInvalidValue is configured for the given signalId or service fails due to development error COM_BUSY: in case the TP-Buffer is locked
Description:	The service Com_InvalidateSignal invalidates the signal with the given SignalId by setting its value to its configured ComSignalDataInvalidValue.	
Available via:	Com.h	

] (SRS_Com_02077)

See Chapter 7.4.4 for further information about the signal invalidation mechanism.

[SWS_Com_00642] [After invaliding the signal data, the function Com_InvalidateSignal shall perform a call of Com_SendSignal internally, for details see SWS_Com_00099.] (SRS_Com_02077)

[SWS_Com_00643] [Com_InvalidateSignal shall return COM_SERVICE_NOT_AVAILABLE in case no ComSignalDataInvalidValue (ECUC_Com_00391) is configured for the signal with the given SignalId.] (SRS_Com_02077)

8.3.3.10 Com_InvalidateSignalGroup

[SWS_Com_00557] [

Service name:	Com_InvalidateSignalGroup	
Syntax:	uint8 Com_InvalidateSignalGroup(Com_SignalGroupIdType SignalGroupId)	
Service ID[hex]:	0x1b	
Sync/Async:	Asynchronous	
Reentrancy:	Non Reentrant for the same signal group. Reentrant for different signal groups.	
Parameters (in):	SignalGroupId Id of signal group to be invalidated.	
Parameters (in-out):	None	
Parameters (out):	None	
Return value:	uint8	E_OK: service has been accepted COM_SERVICE_NOT_AVAILABLE: corresponding I-PDU group is stopped, no ComSignalDataInvalidValue is configured for any of the group signals or service fails due to development error COM_BUSY: in case the TP-Buffer is locked

Description:	The service Com_InvalidateSignalGroup invalidates all group signals of the signal group with the given SignalGroupId by setting their values to their configured ComSignalDataInvalidValues.
Available via:	Com.h

] (SRS_Com_02077)

For further information about the signal invalidation mechanism, see Chapter 7.4.4.

[SWS_Com_00645] [After invaliding the signal group data, the function Com_InvalidateSignalGroup shall perform a call of Com_SendSignalGroup internally.] (SRS_Com_02077)

8.3.3.11 Com_TriggerIPDUSend

[SWS_Com_00348] [

Service name:	Com_TriggerIPDUSend	
Syntax:	Std_ReturnType Com_TriggerIPDUSend(PduldType Pduld)	
Service ID[hex]:	0x17	
Sync/Async:	Synchronous	
Reentrancy:	Non Reentrant	
Parameters (in):	Pduld	The I-PDU-ID of the I-PDU that shall be triggered for sending
Parameters (in-out):	None	
Parameters (out):	None	
Return value:	Std_ReturnType	E_OK: I-PDU was triggered for transmission E_NOT_OK: I-PDU is stopped, the transmission could not be triggered
Description:	By a call to Com_TriggerIPDUSend the I-PDU with the given ID is triggered for transmission.	
Available via:	Com.h	

] (SRS_Com_02037)

[SWS_Com_00861] [By a call to Com_TriggerIPDUSend, the AUTOSAR COM shall trigger the I-PDU with the given ID for transmission only if the I-PDU is started.] (SRS_Com_02037)

In case a stopped I-PDU is triggered for transmission, just E_NOT_OK is returned. For stopped I-PDUs no triggers are stored for a later execution after a potential (re-) starting of the I-PDU.

[SWS_Com_00388] [When an I-PDU is transmitted because of the function Com_TriggerIPDUSend or Com_TriggerIPDUSendWithMetaData, the AUTOSAR COM module shall only take the minimum delay time into account. That is the AUTOSAR COM module shall postpone transmissions if necessary and reset the minimum delay timer in case of transmissions. The AUTOSAR COM module shall not take into account all other transmission mode related parameters like ComTxMode-NumberOfRepetitions.] (SRS_Com_02037)

[SWS_Com_00492] [If an I-PDU triggered by Com_TriggerIPDUSend or Com_TriggerIPDUSendWithMetaData has a configured I-PDU-callout, see ECUC_Com_00387, then the function Com_TriggerIPDUSend or Com_TriggerIPDUSendWithMetaData respectively shall also call this I-PDU-Callout.] (SRS_Com_02037)

If within the Com_TriggerIPDUSend function, another call to Com_TriggerIPDUSend is invoked the application programmer must take care to not create infinite recursions. Both, direct recursions by invoking Com_TriggerIPDUSend with the same ComPduld again and indirect recursions with longer recursion paths are theoretically possible.

The previous paragraph is also true for Com_TriggerIPDUSendWithMetaData as well as for combinations of these two I-PDU triggering functions.

[SWS_Com_00867] [In case a large I-PDU is triggered for transmission by Com_TriggerIPDUSend and the buffer of the large I-PDU is currently locked, the AUTOSAR COM shall store the transmit request and transmit the I-PDU when the buffer is available again.] (SRS_Com_02037)

8.3.3.12 Com_TriggerIPDUSendWithMetaData

[SWS_Com_00858] [

Service name:	Com_TriggerIPDUSendWithMetaData	
Syntax:	Std_ReturnType Com_TriggerIPDUSendWithMetaData(PduldType Pduld, const uint8* MetaData)	
Service ID[hex]:	0x28	
Sync/Async:	Synchronous	
Reentrancy:	Non Reentrant	
Parameters (in):	Pduld	The I-PDU-ID of the I-PDU that shall be triggered for sending
	MetaData	A pointer to the metadata for the triggered send-request
Parameters (in-out):	None	
Parameters (out):	None	
Return value:	Std_ReturnType	E_OK: I-PDU was triggered for transmission E_NOT_OK: I-PDU is stopped, the transmission could not be triggered
	Description: By a call to Com_TriggerIPDUSendWithMetaData the AUTOSAR COM module updates its internal metadata for the I-PDU with the given ID by copying the metadata from the given position and with respect to length of the globally configured MetaDataType of this I-PDU. Then the I-PDU is triggered for transmission.	
Available via:	Com.h	

] (SRS_Com_02037)

[SWS_Com_00862] [By a call to Com_TriggerIPDUSendWithMetaData, the AUTOSAR COM shall trigger the I-PDU with the given ID for transmission only if the I-PDU is started.] (SRS_Com_02037)

In case a stopped I-PDU is triggered for transmission, just E_NOT_OK is returned. There is no mechanism in COM to store the triggering and to execute it after a potential (re-)starting of the I-PDU.

[SWS_Com_00868] [In case a large I-PDU is triggered for transmission by Com_TriggerIPDUSendWithMetaData and the buffer of the large I-PDU is currently locked, the AUTOSAR COM shall store the transmit request with the given MetaData and transmit the I-PDU when the buffer is available again.] (SRS_Com_02037)

8.3.3.13 Com_SwitchIpdUTxMode

[SWS_Com_00784] [

Service name:	Com_SwitchIpdUTxMode	
Syntax:	void Com_SwitchIpdUTxMode(PduldType Pduld, boolean Mode)	
Service ID[hex]:	0x27	
Sync/Async:	Synchronous	
Reentrancy:	Reentrant for different Pdulds. Non reentrant for the same Pduld.	
Parameters (in):	Pduld	Id of the I-PDU of which the transmission mode shall be changed.
	Mode	the transmission mode that shall be set.
Parameters (in-out):	None	
Parameters (out):	None	
Return value:	None	
Description:	The service Com_SwitchIpdUTxMode sets the transmission mode of the I-PDU referenced by Pduld to Mode. In case the transmission mode changes, the new mode shall immediately be effective (see SWS_Com_00239). In case the requested transmission mode was already active for this I-PDU, the call will have no effect.	
Available via:	Com.h	

] (SRS_Com_02082)

[SWS_Com_00881] [When the transmission mode of an I-PDU is explicitly set by Com_SwitchIpdUTxMode, the AUTOSAR COM shall defer the cyclic transmissions of this I-PDU by ComTxModeTimeOffset.] (SRS_Com_02082)

By mixing the signal based TMS and explicit TMS by Com_SwitchIpdUTxMode for the same I-PDU, it must be noted that the signal base TMS might switch back the manual set mode during a call to Com_SendSignal or Com_SendSignalGroup for this I-PDU. Therefore, mixing explicit and manual TMS for one I-PDU must be carefully designed, if used at all.

8.4 Callback Functions and Notifications

8.4.1 Com_TriggerTransmit

[SWS_Com_00001] [

Service name:	Com_TriggerTransmit	
Syntax:	Std_ReturnType Com_TriggerTransmit(PduIdType TxPduId, PduInfoType* PduInfoPtr)	
Service ID[hex]:	0x41	
Sync/Async:	Synchronous	
Reentrancy:	Reentrant for different PduIds. Non reentrant for the same PduId.	
Parameters (in):	TxPduId	ID of the SDU that is requested to be transmitted.
Parameters (in-out):	PduInfoPtr	Contains a pointer to a buffer (SduDataPtr) to where the SDU data shall be copied, and the available buffer size in SduLength. On return, the service will indicate the length of the copied SDU data in SduLength.
Parameters (out):	None	
Return value:	Std_ReturnType	E_OK: SDU has been copied and SduLength indicates the number of copied bytes. E_NOT_OK: No SDU data has been copied. PduInfoPtr must not be used since it may contain a NULL pointer or point to invalid data.
Description:	Within this API, the upper layer module (called module) shall check whether the available data fits into the buffer size reported by PduInfoPtr->SduLength. If it fits, it shall copy its data into the buffer provided by PduInfoPtr->SduDataPtr and update the length of the actual copied data in PduInfoPtr->SduLength. If not, it returns E_NOT_OK without changing PduInfoPtr.	
Available via:	Com.h	

] (SRS_Com_02045)

[SWS_Com_00647] [Within the function Com_TriggerTransmit, the AUTOSAR COM module shall copy the contents of its I-PDU transmit buffer to the L-PDU buffer given by PduInfoPtr->SduDataPtr and update PduInfoPtr->SduLength with length of the copied data accordingly.] (SRS_Com_02045)

[SWS_Com_00869] [In case the given PduInfoPtr->SduLength is smaller than the actual PDU-length, Com_TriggerTransmit shall not copy any data and return E_NOT_OK.] (SRS_Com_02045)

[SWS_Com_00475] [Com_TriggerTransmit is not interfered by the I-PDU minimum delay time and shall not reset the minimum delay timer, see ECUC_Com_00181.] (SRS_Com_02045)

The function Com_TriggerTransmit behaves independent of the configured transmission mode.

Use case: This function is used e.g. by the LIN Master for sending out a LIN frame. In this case, the trigger transmit can be initiated by the Master schedule table itself or a received LIN header. The FlexRay Interface for requesting PDUs to be sent in static part (synchronous to the FlexRay global time) also uses this function.

Once the PDU Router has successfully sent the I-PDU, the PDU Router will call Com_TxConfirmation.

Caveats of Com_TriggerTransmit: This function might be called in interrupt context.

8.4.2 Com_RxIndication

[SWS_Com_00123] [

Service name:	Com_RxIndication	
Syntax:	void Com_RxIndication(PduIdType RxPduId, const PduInfoType* PduInfoPtr)	
Service ID[hex]:	0x42	
Sync/Async:	Synchronous	
Reentrancy:	Reentrant for different PduIds. Non reentrant for the same PduId.	
Parameters (in):	RxPduId	ID of the received PDU.
	PduInfoPtr	Contains the length (SduLength) of the received PDU, a pointer to a buffer (SduDataPtr) containing the PDU, and the MetaData related to this PDU.
Parameters (in-out):	None	
Parameters (out):	None	
Return value:	None	
Description:	Indication of a received PDU from a lower layer communication interface module.	
Available via:	Com.h	

] (SRS_Com_02043)

Caveats of Com_RxIndication: This function might be called in interrupt context.

8.4.3 Com_TpRxIndication

[SWS_Com_00650] [

Service name:	Com_TpRxIndication	
Syntax:	void Com_TpRxIndication(PduIdType id, Std_ReturnType result)	
Service ID[hex]:	0x45	
Sync/Async:	Synchronous	
Reentrancy:	Reentrant	
Parameters (in):	id	Identification of the received I-PDU.
	result	Result of the reception.
Parameters (in-out):	None	
Parameters (out):	None	
Return value:	None	
Description:	Called after an I-PDU has been received via the TP API, the result indicates whether the transmission was successful or not.	
Available via:	Com.h	

] (SRS_Com_02095)

Caveats of Com_TpRxIndication: This function might be called in interrupt context.

8.4.4 Com_TxConfirmation

[SWS_Com_00124] [

Service name:	Com_TxConfirmation	
Syntax:	void Com_TxConfirmation(PduldType TxPduld, Std_ReturnType result)	
Service ID[hex]:	0x40	
Sync/Async:	Synchronous	
Reentrancy:	Reentrant for different Pdulds. Non reentrant for the same Pduld.	
Parameters (in):	TxPduld	ID of the PDU that has been transmitted.
	result	E_OK: The PDU was transmitted. E_NOT_OK: Transmission of the PDU failed.
Parameters (in-out):	None	
Parameters (out):	None	
Return value:	None	
Description:	The lower layer communication interface module confirms the transmission of a PDU, or the failure to transmit a PDU.	
Available via:	Com.h	

] (SRS_Com_02044)

Caveats of Com_TxConfirmation: This function might be called in interrupt context, e.g. from transmit interrupt.

8.4.5 Com_TpTxConfirmation

[SWS_Com_00725] [

Service name:	Com_TpTxConfirmation	
Syntax:	void Com_TpTxConfirmation(PduldType id, Std_ReturnType result)	
Service ID[hex]:	0x48	
Sync/Async:	Synchronous	
Reentrancy:	Reentrant	
Parameters (in):	id	Identification of the transmitted I-PDU.
	result	Result of the transmission of the I-PDU.
Parameters (in-out):	None	
Parameters (out):	None	
Return value:	None	
Description:	This function is called after the I-PDU has been transmitted on its network, the result indicates whether the transmission was successful or not.	
Available via:	Com.h	

] (SRS_Com_02095)

8.4.6 Com_StartOfReception

[SWS_Com_00691] [

Service name:	Com_StartOfReception	
Syntax:	BufReq_ReturnType Com_StartOfReception(PduldType id, const PdulInfoType* info,	

	PduLengthType TpSduLength, PduLengthType* bufferSizePtr)	
Service ID[hex]:	0x46	
Sync/Async:	Synchronous	
Reentrancy:	Reentrant	
Parameters (in):	id	Identification of the I-PDU.
	info	Pointer to a PduInfoType structure containing the payload data (without protocol information) and payload length of the first frame or single frame of a transport protocol I-PDU reception, and the MetaData related to this PDU. If neither first/single frame data nor MetaData are available, this parameter is set to NULL_PTR.
	TpSduLength	Total length of the N-SDU to be received.
Parameters (in-out):	None	
Parameters (out):	bufferSizePtr	Available receive buffer in the receiving module. This parameter will be used to compute the Block Size (BS) in the transport protocol module.
Return value:	BufReq_ReturnType	BUFREQ_OK: Connection has been accepted. bufferSizePtr indicates the available receive buffer; reception is continued. If no buffer of the requested size is available, a receive buffer size of 0 shall be indicated by bufferSizePtr. BUFREQ_E_NOT_OK: Connection has been rejected; reception is aborted. bufferSizePtr remains unchanged. BUFREQ_E_OVFL: No buffer of the required length can be provided; reception is aborted. bufferSizePtr remains unchanged.
Description:	This function is called at the start of receiving an N-SDU. The N-SDU might be fragmented into multiple N-PDUs (FF with one or more following CFs) or might consist of a single N-PDU (SF). The service shall provide the currently available maximum buffer size when invoked with TpSduLength equal to 0.	
Available via:	Com.h	

] (SRS_Com_02095)

[SWS_Com_00654] [If ComRxPduId corresponds to a large I-PDU and TpSduLength is greater than the configured length of this I-PDU then the function Com_StartOfReception shall return BUFREQ_E_OVFL.] (SRS_Com_02095)

[SWS_Com_00655] [If ComRxPduId corresponds to a dynamic length I-PDU and TpSduLength is greater than the configured maximum length of this I-PDU then the function Com_StartOfReception shall return BUFREQ_E_OVFL.] (SRS_Com_02095)

[SWS_Com_00657] [If the internal AUTOSAR COM module's buffer is currently not locked and the parameter TpSduLength does not exceed the (maximum) expected length, the function Com_StartOfReception shall write the complete size of the AUTOSAR COM module's internal I-PDU buffer of the I-PDU with handle ComRxPduId to the position given by RxBufferSizePtr.] (SRS_Com_02095)

[SWS_Com_00721] [Com_StartOfReception shall return BUFREQ_E_NOT_OK, in case ComRxPduId refers to a stopped I-PDU.] (SRS_Com_02095)

[SWS_Com_00818] [In case Com_StartOfReception returns BUFREQ_E_NOT_OK or BUFREQ_E_OVFL, the AUTOSAR COM module shall not expect a call to Com_TpRxIndication and hence shall not lock its internal buffer.] (SRS_Com_02095)

[SWS_Com_00874] [In case Com_StartOfReception is called with TpSduLength equal to 0, the AUTOSAR COM module shall return the configured (maximum) length of this I-PDU via the bufferSizePtr.] (SRS_Com_02095)

A TpSduLength equal to 0 indicates an unknown message length.

8.4.7 Com_CopyRxData

[SWS_Com_00692] [

Service name:	Com_CopyRxData	
Syntax:	BufReq_ReturnType Com_CopyRxData(PduldType id, const PdulInfoType* info, PduLengthType* bufferSizePtr)	
Service ID[hex]:	0x44	
Sync/Async:	Synchronous	
Reentrancy:	Reentrant	
Parameters (in):	id	Identification of the received I-PDU.
	info	Provides the source buffer (SduDataPtr) and the number of bytes to be copied (SduLength). An SduLength of 0 can be used to query the current amount of available buffer in the upper layer module. In this case, the SduDataPtr may be a NULL_PTR.
Parameters (in-out):	None	
Parameters (out):	bufferSizePtr	Available receive buffer after data has been copied.
Return value:	BufReq_ReturnType	BUFREQ_OK: Data copied successfully BUFREQ_E_NOT_OK: Data was not copied because an error occurred.
Description:	This function is called to provide the received data of an I-PDU segment (N-PDU) to the upper layer. Each call to this function provides the next part of the I-PDU data. The size of the remaining buffer is written to the position indicated by bufferSizePtr.	
Available via:	Com.h	

] (SRS_Com_02095)

Caveats of Com_CopyRxData: This function might be called in interrupt context. Therefore, data consistency must be ensured.

[SWS_Com_00782] [Com_CopyRxData shall copy no data and return BUFREQ_E_NOT_OK in case the given Pduld refers to a stopped I-PDU.] (SRS_Com_00218)

8.4.8 Com_CopyTxData

[SWS_Com_00693] [

Service name:	Com_CopyTxData	
Syntax:	BufReq_ReturnType Com_CopyTxData(PduIdType id, const PduInfoType* info, const RetryInfoType* retry, PduLengthType* availableDataPtr)	
Service ID[hex]:	0x43	
Sync/Async:	Synchronous	
Reentrancy:	Reentrant	
Parameters (in):	id	Identification of the transmitted I-PDU.
	info	Provides the destination buffer (SduDataPtr) and the number of bytes to be copied (SduLength). If not enough transmit data is available, no data is copied by the upper layer module and BUFREQ_E_BUSY is returned. The lower layer module may retry the call. An SduLength of 0 can be used to indicate state changes in the retry parameter or to query the current amount of available data in the upper layer module. In this case, the SduDataPtr may be a NULL_PTR.
	retry	This parameter is used to acknowledge transmitted data or to retransmit data after transmission problems. If the retry parameter is a NULL_PTR, it indicates that the transmit data can be removed from the buffer immediately after it has been copied. Otherwise, the retry parameter must point to a valid RetryInfoType element. If TpDataState indicates TP_CONFENDING, the previously copied data must remain in the TP buffer to be available for error recovery. TP_DATACONF indicates that all data that has been copied before this call is confirmed and can be removed from the TP buffer. Data copied by this API call is excluded and will be confirmed later. TP_DATARETRY indicates that this API call shall copy previously copied data in order to recover from an error. In this case TxTpDataCnt specifies the offset in bytes from the current data copy position.
Parameters (in-out):	None	
Parameters (out):	availableDataPtr	Indicates the remaining number of bytes that are available in the upper layer module's Tx buffer. availableDataPtr can be used by TP modules that support dynamic payload lengths (e.g. FrlsoTp) to determine the size of the following CFs.
Return value:	BufReq_ReturnType	BUFREQ_OK: Data has been copied to the transmit buffer completely as requested. BUFREQ_E_BUSY: Request could not be fulfilled, because the required amount of Tx data is not available. The lower layer module may retry this call later on. No data has been copied. BUFREQ_E_NOT_OK: Data has not been copied. Request failed.
Description:	This function is called to acquire the transmit data of an I-PDU segment (N-PDU). Each call to this function provides the next part of the I-PDU data unless retry->TpDataState is TP_DATARETRY. In this case the function restarts to copy the data beginning at the offset from the current position indicated by retry->TxTpDataCnt. The size of the remaining data is written to the position indicated by availableDataPtr.	

Available via:	Com.h
-----------------------	-------

] (SRS_Com_02095)

Caveats of Com_CopyTxData: This function might be called in interrupt context.

[SWS_Com_00783] [Com_CopyTxData shall copy no data and return BU-FREQ_E_NOT_OK in case the given Pduld refers to a stopped I-PDU.] (SRS_Com_00218)

8.5 Scheduled Functions

8.5.1 Com_MainFunctionRx

[SWS_Com_00398] [

Service name:	Com_MainFunctionRx
Syntax:	void Com_MainFunctionRx(void)
Service ID[hex]:	0x18
Description:	This function performs the processing of the AUTOSAR COM module's receive processing that are not directly handled within the COM's functions invoked by the PDU-R, for example Com_RxIndication.
Available via:	SchM_Com.h

] (SRS_BSW_00425, SRS_BSW_00432)

[SWS_Com_00664] [A call to Com_MainFunctionRx shall simply return if the AUTOSAR COM module was not previously initialized with a call to Com_Init.] (SRS_BSW_00425)

Configuration of Com_MainFunctionRx: see ECUC_Com_00186.

8.5.2 Com_MainFunctionTx

[SWS_Com_00399] [

Service name:	Com_MainFunctionTx
Syntax:	void Com_MainFunctionTx(void)
Service ID[hex]:	0x19
Description:	This function performs the processing of the AUTOSAR COM module's transmission activities that are not directly handled within the COM's function invoked by the RTE, for example Com_SendSignal.
Available via:	SchM_Com.h

] (SRS_BSW_00425, SRS_BSW_00432)

[SWS_Com_00665] [A call to Com_MainFunctionTx shall simply return if the AUTOSAR COM module was not previously initialized with a call to Com_Init.] (SRS_BSW_00425)

Configuration: see ECUC_Com_00186.

8.5.3 Com_MainFunctionRouteSignals

[SWS_Com_00400] [

Service name:	Com_MainFunctionRouteSignals
Syntax:	void Com_MainFunctionRouteSignals(void)
Service ID[hex]:	0x1a
Description:	Calls the signal gateway part of the AUTOSAR COM module to forward received signals to be routed.
Available via:	SchM_Com.h

] (SRS_BSW_00425, SRS_BSW_00432)

[SWS_Com_00666] [A call to Com_MainFunctionRouteSignals shall simply return if the AUTOSAR COM module was not previously initialized with a call to Com_Init.] (SRS_BSW_00425)

Caveats of Com_MainFunctionRouteSignals:

- The time between two consecutive calls (perhaps the related task/thread cycle) affects directly the signal gateway latency.
- The insertion of this call is necessary for decoupling receive interrupts and signal gateway tasks.
- Normally a cyclic task/ thread to call this function is configured. The cycle of this task/thread directly affects the latency of the signal gateway.

8.6 Expected Interfaces

8.6.1 Mandatory Interfaces

This chapter defines all interfaces, which are required to fulfill the core functionality of the module.

[SWS_Com_00669] [

API function	Header File	Description
PduR_ComTransmit	PduR_Com.h	Requests transmission of a PDU.

] (SRS_BSW_00384)

8.6.2 Optional Interfaces

This chapter defines all interfaces that are required to fulfill an optional functionality of the module.

[SWS_Com_00670] [

API function	Header File	Description
Det_ReportError	Det.h	Service to report development errors.
Det_ReportRuntimeError	Det.h	Service to report runtime errors. If a callout has been

		configured then this callout shall be called.
PduR_ComCancelTransmit	PduR_Com.h	Requests cancellation of an ongoing transmission of a PDU in a lower layer communication module.

] (SRS_BSW_00384)

The associated configuration parameter for API function Det_ReportError is ComConfigurationUseDet (ECUC_Com_00141).

The API function PduR_ComCancelTransmit must be included if at least one I-PDU has configured ComIPduCancellationSupport to TRUE, see ECUC_Com_00709.

8.6.3 Configurable Interfaces

8.6.3.1 Callback/ Notification Functions

Caveats of configurable interfaces: A callback routine runs either on interrupt level or on task level. Thus, the OS restrictions of usage of system functions for interrupt service routines as well as for tasks apply.

[SWS_Com_00468] [

Service name:	Com_CbkTxAck
Syntax:	void Com_CbkTxAck(void)
Sync/Async:	Synchronous
Reentrancy:	don't care
Parameters (in):	None
Parameters (in-out):	None
Parameters (out):	None
Return value:	None
Description:	This callback represents notification class 2 of [17]. It is called immediately after successful transmission of the I-PDU containing the message.
Available via:	configurable

] (SRS_BSW_00359, SRS_BSW_00360)

Com_CbkTxAck is called on sender side only. It can be configured for signals and signal groups.

Com_CbkTxAck corresponds to Rte_COMCbKtAck_<sn> or Rte_COMCbKtAck_<sg> respectively.

The callback function name must be configured by ComNotification (ECUC_Com_00498).

[SWS_Com_00491] [

Service name:	Com_CbkTxErr
Syntax:	void Com_CbkTxErr(

	void)
Sync/Async:	Synchronous
Reentrancy:	don't care
Parameters (in):	None
Parameters (in-out):	None
Parameters (out):	None
Return value:	None
Description:	This callback corresponds to notification class 4 of [17]. It is called in case the transmission is not possible because the corresponding I-PDU group is stopped.
Available via:	configurable

] (SRS_BSW_00359, SRS_BSW_00360)

Com_CbkTxErr is called on sender side only. This callback function corresponds to Rte_COMCbKTErr_<sn> or Rte_COMCbKTErr_<sg> respectively.

The callback function name must be configured by ComErrorNotification (ECUC_Com_00499).

[SWS_Com_00554] [

Service name:	Com_CbkTxTOut
Syntax:	void Com_CbkTxTOut(void)
Sync/Async:	Synchronous
Reentrancy:	don't care
Parameters (in):	None
Parameters (in-out):	None
Parameters (out):	None
Return value:	None
Description:	This callback corresponds to notification class 4 of [17]. It is called immediately after a message transmission error has been detected by the deadline monitoring mechanism.
Available via:	configurable

] (SRS_BSW_00359, SRS_BSW_00360)

Com_CbkTxTOut is called on sender side only. It can be configured for signals and signal groups.

This callback function corresponds to Rte_COMCbKTxTOut_<sn> or Rte_COMCbKTxTOut_<sg> respectively.

The callback function name must be configured by ComTimeoutNotification (ECUC_Com_00552).

[SWS_Com_00555] [

Service name:	Com_CbkRxAck
Syntax:	void Com_CbkRxAck(void)
Sync/Async:	Synchronous

Reentrancy:	don't care
Parameters (in):	None
Parameters (in-out):	None
Parameters (out):	None
Return value:	None
Description:	This callback represents notification class 1 of [17]. It is called immediately after the message has been stored in the receiving message object.
Available via:	configurable

] (SRS_BSW_00359, SRS_BSW_00360)

Com_CbkRxAck is called on receiver side only. It can be configured for signals and signal groups.

Com_CbkRxAck corresponds to Rte_COMCbk_<sn> or Rte_COMCbk_<sg> respectively.

The callback function name must be configured by ComNotification (ECUC_Com_00498).

[SWS_Com_00556] [

Service name:	Com_CbkRxTOut
Syntax:	void Com_CbkRxTOut(void)
Sync/Async:	Synchronous
Reentrancy:	don't care
Parameters (in):	None
Parameters (in-out):	None
Parameters (out):	None
Return value:	None
Description:	This callback corresponds to notification class 3 of [17]. It is called immediately after a message reception error has been detected by the deadline monitoring mechanism.
Available via:	configurable

] (SRS_BSW_00359, SRS_BSW_00360)

Com_CbkRxTOut is called on receiver side only. It can be configured for signals and signal groups.

This callback function corresponds to Rte_COMCbkRxTOut_<sn> or Rte_COMCbkRxTOut_<sg> respectively.

The callback function name must be configured by ComTimeoutNotification (see ECUC_Com_00552).

[SWS_Com_00536] [

Service name:	Com_CbkInv
Syntax:	void Com_CbkInv(void)

Sync/Async:	Synchronous
Reentrancy:	don't care
Parameters (in):	None
Parameters (in-out):	None
Parameters (out):	None
Return value:	None
Description:	This callback function corresponds to SWS_Com_00680. It is called after reception of an invalid signal or signal group respectively.
Available via:	configurable

] (SRS_BSW_00359, SRS_BSW_00360, SRS_Com_02079)

Com_CbkInv is called on receiver side only. It can be configured for signals, group signals and signal groups.

This callback function corresponds to Rte_COMCbkInv_<sn> (for signals and group signals) and Rte_COMCbkInv_<sg> respectively.

The callback function name must be configured by ComInvalidNotification (ECUC_Com_00315).

[SWS_Com_00726] [

Service name:	Com_CbkCounterErr	
Syntax:	void Com_CbkCounterErr(PduldType ComPduld, uint8 ExpectedCounter, uint8 ReceivedCounter)	
Sync/Async:	Synchronous	
Reentrancy:	don' t care	
Parameters (in):	ComPduld	Id of the I-PDU for that a counter mismatch was detected
	ExpectedCounter	The expected counter value
	ReceivedCounter	The received counter value
Parameters (in-out):	None	
Parameters (out):	None	
Return value:	None	
Description:	This function is called immediately, if the AUTOSAR COM module receives an I-PDU counter that differs from the expected one.	
Available via:	configurable	

] (SRS_Com_02102)

Com_CbkCounterErr is called on receiver side only. It can be configured per I-PDU counter. The callback function name must be configured by ComIPduCounterErrorNotification (ECUC_Com_00003).

8.6.3.2 I-PDU Callout Functions

As stated in SWS_Com_00013 *Network-order message callout* and *CPU-order message callout* are not supported by the AUTOSAR COM module. The only callout method supported by the AUTOSAR COM module therefore is the I-PDU callout. The AUTOSAR COM module supports I-PDU callouts on sender and on receiver side.

As specified in [17], if the I-PDU callout returns false the I-PDU will not be processed any further.

[SWS_Com_00700] [

Service name:	Com_RxIpdCallout	
Syntax:	boolean Com_RxIpdCallout(PduldType Pduld, const PduldInfoType* PduldInfoPtr)	
Service ID[hex]:	0x2A	
Sync/Async:	Synchronous	
Reentrancy:	don't care	
Parameters (in):	Pduld	ID of the received I-PDU.
	PduldInfoPtr	Contains the length (SduLength) of the received I-PDU and a pointer to the data of the I-PDU (SduDataPtr).
Parameters (in-out):	None	
Parameters (out):	None	
Return value:	boolean	true: I-PDU will be processed normal false: I-PDU will not be processed any further
Description:	The I-PDU callout on receiver side can be configured to implement user-defined receive filtering mechanisms.	
Available via:	configurable	

] (SRS_Com_02037)

The callout function name must be configured by ComIPduCallout (ECUC_Com_00387).

[SWS_Com_00816] [The AUTOSAR COM module shall forward all data of the received I-PDU (i.e. the complete I-PDU as provided by the PduR) in the Com_RxIpdCallout.] (SRS_Com_02037)

[SWS_Com_00346] [

Service name:	Com_TxIpdCallout	
Syntax:	boolean Com_TxIpdCallout(PduldType Pduld, PduldInfoType* PduldInfoPtr)	
Service ID[hex]:	0x29	
Sync/Async:	Synchronous	
Reentrancy:	don't care	
Parameters (in):	Pduld	ID of the transmitted I-PDU.
	PduldInfoPtr	Contains the length (SduLength) of the transmitted I-PDU and a pointer to the data of the I-PDU (SduDataPtr).
Parameters (in-out):	None	
Parameters (out):	None	
Return value:	boolean	true: I-PDU will be processed normal false: I-PDU will not be processed any further
Description:	The I-PDU callout on sender side can be configured for example to implement user-defined transmission filtering or user-defined pre-transmission-processing of the outgoing I-PDU.	
Available via:	configurable	

] (SRS_Com_02037)

The callout function name must be configured either by `ComIPduCallout` (ECUC_Com_00387) or by `ComIPduTriggerTransmitCallout` (ECUC_Com_00765).

The AUTOSAR COM module implements no means to detect or prevent possible recursions that may occur when I-PDUs are triggered by actions within an I-PDU callout. It is solely in the responsibility of the implementer of an I-PDU callout and the system integrator that unwanted or endless chains of I-PDU callouts are avoided.

[SWS_Com_00381] [The AUTOSAR COM module shall not support that other AUTOSAR COM module's APIs than `Com_TriggerIPDUSend`, `Com_TriggerIPDUSend-WithMetaData`, `Com_SendSignal` and `Com_SendSignalGroup` can be called out of an I-PDU callout.] (SRS_Com_02037)

[SWS_Com_00766] [In case a `ComIPduTriggerTransmitCallout` is configured for an I-PDU and the I-PDU is started, the AUTOSAR COM module shall invoke this I-PDU callout within every execution of `Com_TriggerTransmit` for this I-PDU.] (SRS_Com_02037)

[SWS_Com_00395] [When `Com_TriggerTransmit` is called, the AUTOSAR COM module shall ignore the return value from the `ComIPduTriggerTransmitCallout`.] (SRS_Com_02037)

[SWS_Com_00719] [In case a `ComIPduCallout` is configured for an I-PDU with `ComIPduDirection` configured to *SEND*, the AUTOSAR COM module shall invoke this I-PDU callout directly before the I-PDU is transmitted via `PduR_ComTransmit`.] (SRS_Com_02037)

For TP I-PDUs, the I-PDU callout functions are handled similar to the I-PDU callout functions of normal I-PDUs and are supported both on transmitter and receiver side. Note that for example the requirement `SWS_Com_00719` does not consider the configured `ComIPduType`.

[SWS_Com_00720] [When a large I-PDU is received successfully via the TP interface, the I-PDU callout shall take place within the invocation of `Com_TpRxIndication`.] (SRS_Com_02095)

[SWS_Com_00839] [When the I-PDU callout in context of `Com_TpRxIndication` returns false, the I-PDU shall be considered as incorrectly received and therefore all included signals shall be treated exactly like invalidated signals. That is, the AUTOSAR COM module shall execute all configured `ComDataInvalidActions` for all included signals and signal groups.] (SRS_Com_02095)

9 Sequence Diagrams

A sequence diagram of the underlying communication stack can be found in [17].

9.1 Interface between the AUTOSAR COM Module and the PDU Router

The following chart shows the communication between the AUTOSAR COM module and the PDU Router.

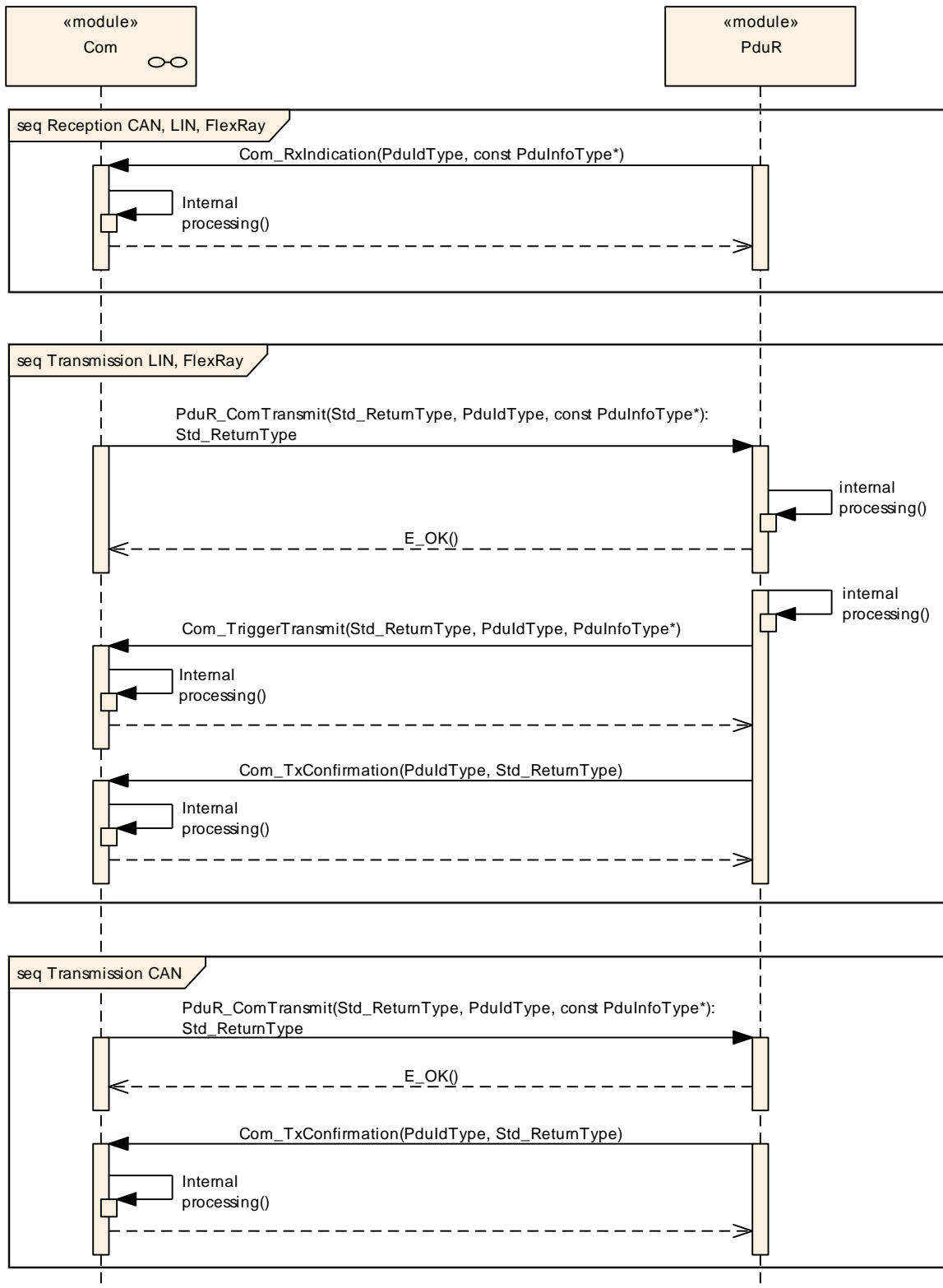

Figure 6: Interactions between the AUTOSAR COM module and the PDU router

9.2 Confirmation Handling between the PDU Router, the AUTOSAR COM Module and the RTE

The following chart shows the confirmation handling with respect to the two different IPDU-processing modes. (See also Chapter 7.3.5.4.)

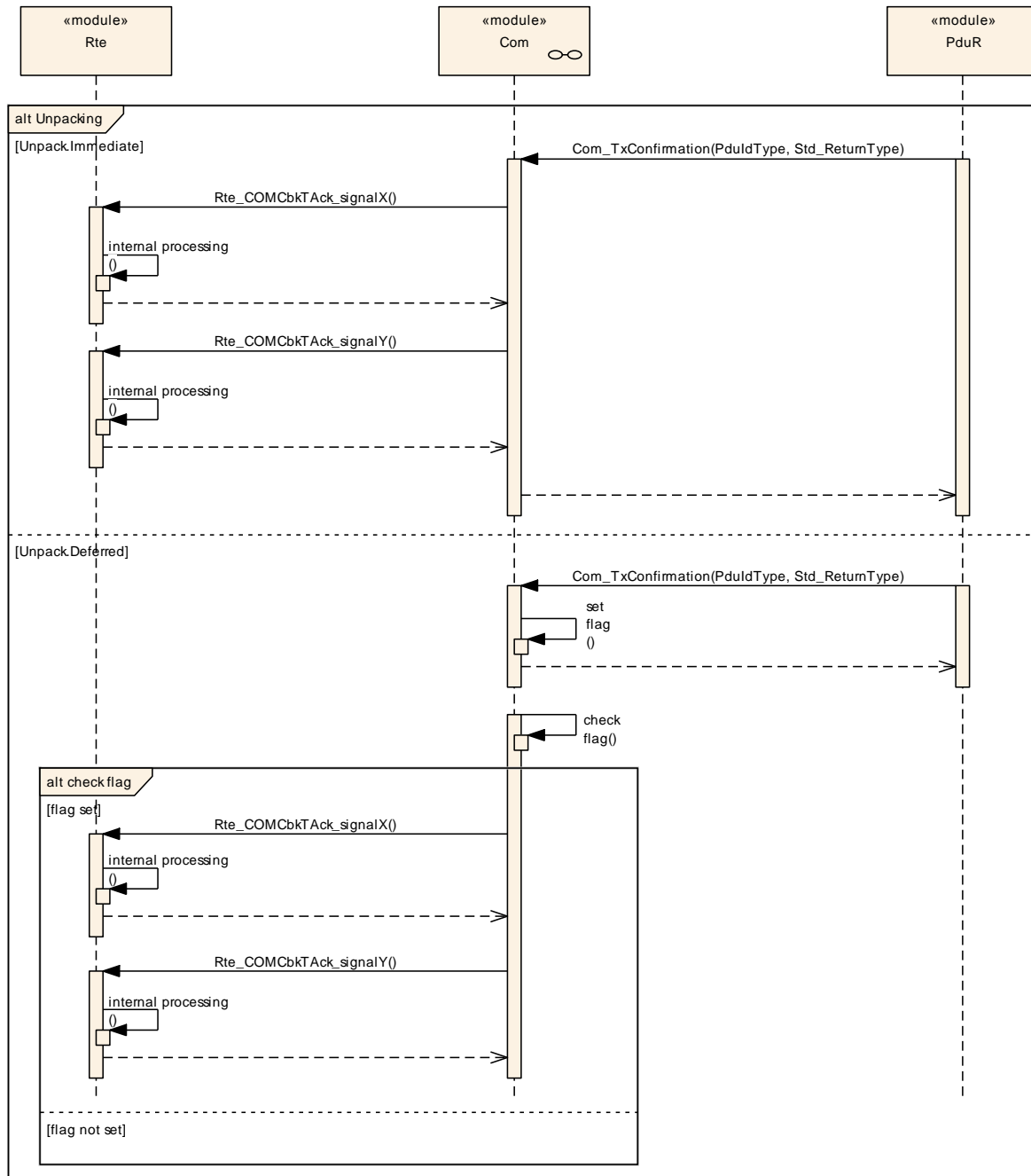

Figure 7: Confirmation handling between the PDU Router, the AUTOSAR COM module and the RTE

9.3 Indication Handling between the PDU Router, the AUTOSAR COM Module and the RTE

The following chart shows the indication handling with respect to the two different unpacking modes. (See also Chapter 7.3.5.4.)

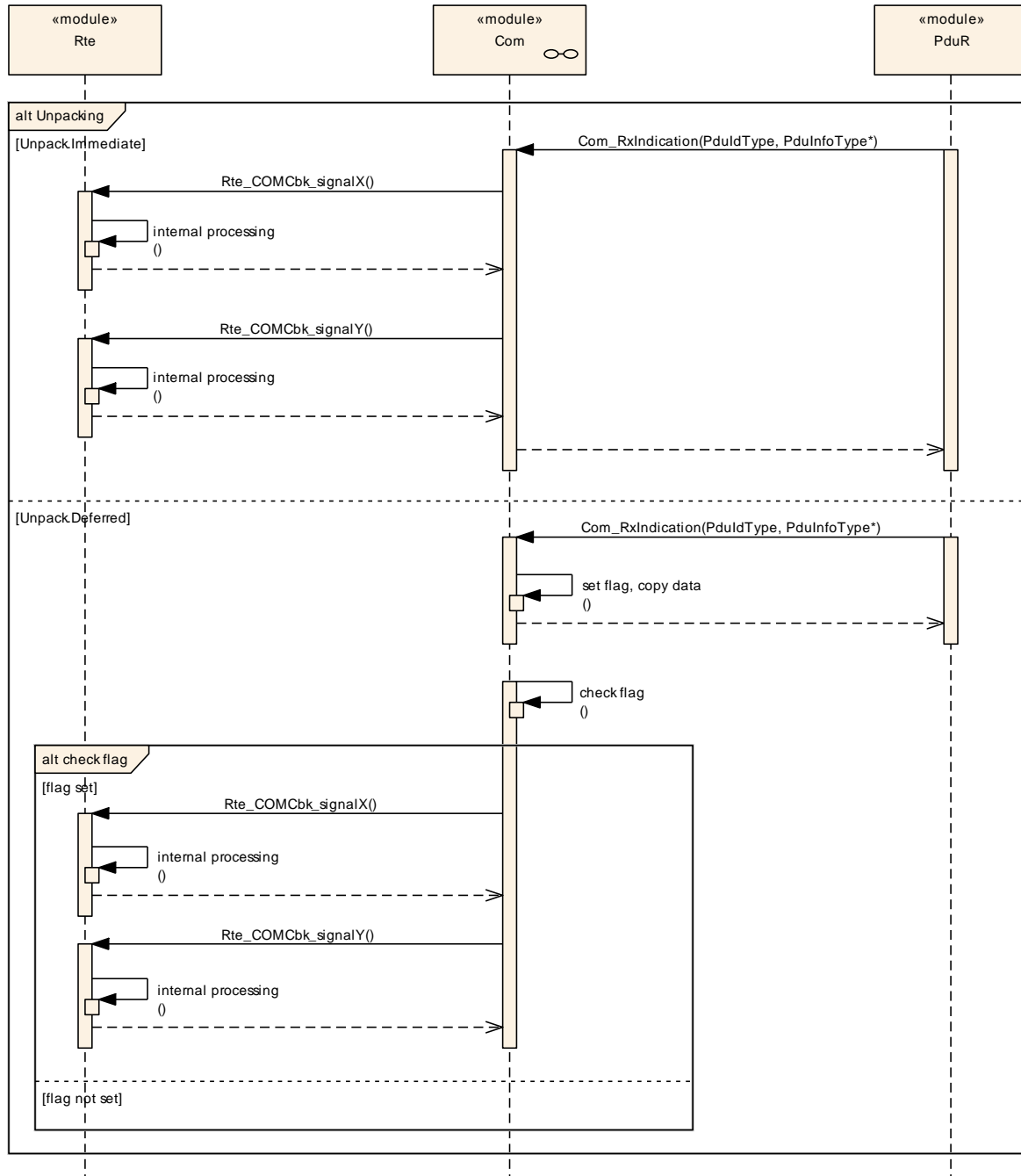

Figure 8: Indication handling between the PDU Router, the AUTOSAR COM module and the RTE

10 Configuration Specification

10.1 Containers and Configuration Parameters

The following chapters summarize all configuration parameters. The detailed meanings of the parameters are described in Chapter 7 and Chapter 8.

[SWS_Com_00006] [The configuration parameters are based on [18]. All parameters shall be stored in an XML format.] (SRS_Com_02040)

10.1.1 Configuration of the AUTOSAR COM Module

For an overview of the AUTOSAR COM module's configuration, see Figure 9.

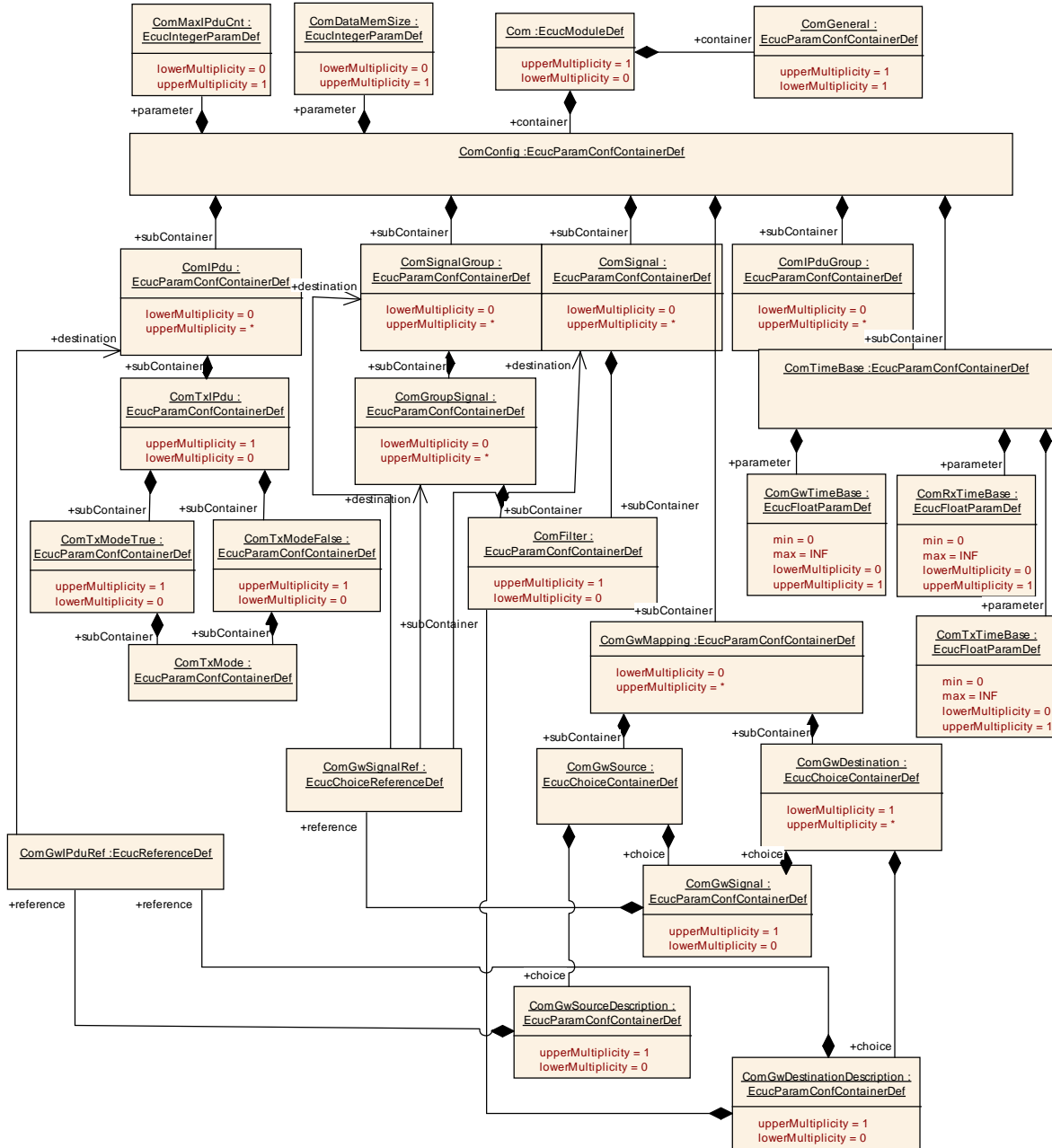

Figure 9: The AUTOSAR COM module's Configuration Overview

10.1.2 Com

SWS Item	ECUC_Com_00540 :
Module Name	Com
Module Description	Configuration of the AUTOSAR COM module.
Post-Build Variant Support	true
Supported Config Variants	VARIANT-LINK-TIME, VARIANT-POST-BUILD, VARIANT-PRE-COMPILE

Included Containers		
Container Name	Multiplicity	Scope / Dependency
ComConfig	1	This container contains the configuration parameters and sub containers of the AUTOSAR COM module.
ComGeneral	1	Contains the general configuration parameters of the AUTOSAR COM module.

10.1.3 ComGeneral

SWS Item	ECUC_Com_00541 :
Container Name	ComGeneral
Description	Contains the general configuration parameters of the module.
Configuration Parameters	

SWS Item	ECUC_Com_10000 :		
Name	ComCancellationSupport		
Parent Container	ComGeneral		
Description	This parameter enables/disables the cancellation feature: true: enabled false: disabled		
Multiplicity	0..1		
Type	EcucBooleanParamDef		
Default value	true		
Post-Build Variant Multiplicity	false		
Post-Build Variant Value	false		
Multiplicity Configuration Class	Pre-compile time	X	All Variants
	Link time	--	
	Post-build time	--	
Value Configuration Class	Pre-compile time	X	All Variants
	Link time	--	
	Post-build time	--	
Scope / Dependency	scope: local		

SWS Item	ECUC_Com_00141 :		
Name	ComConfigurationUseDet		
Parent Container	ComGeneral		
Description	The error hook shall contain code to call the Det. If this parameter is configured COM_DEV_ERROR_DETECT shall be set to ON as output of the configuration tool. (as input for the source code).		
Multiplicity	0..1		
Type	EcucBooleanParamDef		
Default value	--		

Post-Build Variant Multiplicity	false		
Post-Build Variant Value	false		
Multiplicity Configuration Class	Pre-compile time	X	All Variants
	Link time	--	
	Post-build time	--	
Value Configuration Class	Pre-compile time	X	All Variants
	Link time	--	
	Post-build time	--	
Scope / Dependency	scope: local		

SWS Item	ECUC_Com_00788 :		
Name	ComEnableMDTForCyclicTransmission		
Parent Container	ComGeneral		
Description	Enables globally for the whole Com module the minimum delay time monitoring for cyclic and repeated transmissions (ComTxModeMode=PERIODIC or ComTxModeMode=MIXED for the cyclic transmissions, ComTxModeNumberOfRepetitions > 0 for repeated transmissions).		
Multiplicity	0..1		
Type	EcucBooleanParamDef		
Default value	true		
Post-Build Variant Multiplicity	false		
Post-Build Variant Value	false		
Multiplicity Configuration Class	Pre-compile time	X	All Variants
	Link time	--	
	Post-build time	--	
Value Configuration Class	Pre-compile time	X	All Variants
	Link time	--	
	Post-build time	--	
Scope / Dependency	scope: local		

SWS Item	ECUC_Com_10002 :		
Name	ComEnableSignalGroupArrayApi		
Parent Container	ComGeneral		
Description	Activate/Deactivate the signal group array access APIs (Com_SendSignalGroupArray, Com_ReceiveSignalGroupArray). true: signal group array access APIs activated false: signal group array access APIs deactivated		
Multiplicity	1		
Type	EcucBooleanParamDef		
Default value	false		
Post-Build Variant Value	false		
Value Configuration Class	Pre-compile time	X	All Variants
	Link time	--	
	Post-build time	--	
Scope / Dependency	scope: local		

SWS Item	ECUC_Com_10004 :		
Name	ComMetaDataSupport		
Parent Container	ComGeneral		
Description	This parameter enables/disables the support of meta-data feature including the API Com_TriggerIPDUSendWithMetaData. true: enabled		

	false: disabled		
Multiplicity	0..1		
Type	EcucBooleanParamDef		
Default value	false		
Post-Build Variant Multiplicity	false		
Post-Build Variant Value	false		
Multiplicity Configuration Class	Pre-compile time	X	All Variants
	Link time	--	
	Post-build time	--	
Value Configuration Class	Pre-compile time	X	All Variants
	Link time	--	
	Post-build time	--	
Scope / Dependency	scope: local		

SWS Item	ECUC_Com_00780 :		
Name	ComRetryFailedTransmitRequests		
Parent Container	ComGeneral		
Description	If this Parameter is set to true, retry of failed transmission requests is enabled. If this Parameter is not present, the default value is assumed.		
Multiplicity	0..1		
Type	EcucBooleanParamDef		
Default value	false		
Post-Build Variant Multiplicity	false		
Post-Build Variant Value	false		
Multiplicity Configuration Class	Pre-compile time	X	All Variants
	Link time	--	
	Post-build time	--	
Value Configuration Class	Pre-compile time	X	All Variants
	Link time	--	
	Post-build time	--	
Scope / Dependency	scope: local		

SWS Item	ECUC_Com_00710 :		
Name	ComSupportedIPduGroups		
Parent Container	ComGeneral		
Description	Defines the maximum number of supported I-PDU groups.		
Multiplicity	1		
Type	EcucIntegerParamDef		
Range	0 .. 65535		
Default value	--		
Post-Build Variant Value	false		
Value Configuration Class	Pre-compile time	X	All Variants
	Link time	--	
	Post-build time	--	
Scope / Dependency	scope: local		

SWS Item	ECUC_Com_10001 :		
Name	ComUserCbkJHeaderFile		
Parent Container	ComGeneral		
Description	Defines the header files for callback functions which shall be included by the COM module.		
Multiplicity	0..*		
Type	EcucStringParamDef		
Default value	--		

maxLength	32		
minLength	1		
regularExpression	--		
Post-Build Variant Multiplicity	false		
Post-Build Variant Value	false		
Multiplicity Configuration Class	Pre-compile time	X	All Variants
	Link time	--	
	Post-build time	--	
Value Configuration Class	Pre-compile time	X	All Variants
	Link time	--	
	Post-build time	--	
Scope / Dependency	scope: local		

SWS Item	ECUC_Com_00438 :		
Name	ComVersionInfoApi		
Parent Container	ComGeneral		
Description	Activate/Deactivate the version information API (Com_GetVersionInfo). True: version information API activated False: version information API deactivated		
Multiplicity	1		
Type	EcucBooleanParamDef		
Default value	false		
Post-Build Variant Value	false		
Value Configuration Class	Pre-compile time	X	All Variants
	Link time	--	
	Post-build time	--	
Scope / Dependency	scope: local		

No Included Containers

10.1.4 ComConfig

SWS Item	ECUC_Com_00337 :		
Container Name	ComConfig		
Description	This container contains the configuration parameters and sub containers of the AUTOSAR COM module.		
Configuration Parameters			

SWS Item	ECUC_Com_00783 :		
Name	ComDataMemSize		
Parent Container	ComConfig		
Description	Size of internal Com data in units of bytes (static memory allocation) - memory required by post-build configuration must be smaller than this constant. This parameter is needed only in case of post-build loadable implementation using static memory allocation.		
Multiplicity	0..1		
Type	EcucIntegerParamDef		
Range	0 ..	18446744073709551615	
Default value	--		
Post-Build Variant Multiplicity	false		

Post-Build Variant Value	false		
Multiplicity Configuration Class	Pre-compile time	X	VARIANT-PRE-COMPILE
	Link time	X	VARIANT-LINK-TIME, VARIANT-POST-BUILD
	Post-build time	--	
Value Configuration Class	Pre-compile time	X	VARIANT-PRE-COMPILE
	Link time	X	VARIANT-LINK-TIME, VARIANT-POST-BUILD
	Post-build time	--	
Scope / Dependency	scope: local		

SWS Item	ECUC_Com_00782 :		
Name	ComMaxIPduCnt		
Parent Container	ComConfig		
Description	Maximum number of IPdus. This parameter is needed only in case of post-build loadable implementation using static memory allocation.		
Multiplicity	0..1		
Type	EcucIntegerParamDef		
Range	0 ..	18446744073709551615	
Default value	--		
Post-Build Variant Multiplicity	false		
Post-Build Variant Value	false		
Multiplicity Configuration Class	Pre-compile time	X	VARIANT-PRE-COMPILE
	Link time	X	VARIANT-LINK-TIME, VARIANT-POST-BUILD
	Post-build time	--	
Value Configuration Class	Pre-compile time	X	VARIANT-PRE-COMPILE
	Link time	X	VARIANT-LINK-TIME, VARIANT-POST-BUILD
	Post-build time	--	
Scope / Dependency	scope: local		

Included Containers		
Container Name	Multiplicity	Scope / Dependency
ComGwMapping	0..*	Each instance of this container defines one mapping of the integrated Signal Gateway.
ComIPdu	0..*	See ECUC_Com_00340, if there is no ComIpdu container included no IPDUs are defined. In this case no communication via the AUTOSAR COM module is possible.
ComIPduGroup	0..*	See ECUC_Com_00341, if there is no ComIPduGroup container included then no IPDU group is defined. In this case no communication via the AUTOSAR COM module is possible.
ComSignal	0..*	See ECUC_Com_00344, if there is no ComSignal container included no single signals are defined.
ComSignalGroup	0..*	See ECUC_Com_00345, if there is no ComSignalGroup container included no signal groups are defined.
ComTimeBase	1	Contains the timebase parameters for Tx, Rx and routing.

10.1.5 ComTimeBase

SWS Item	ECUC_Com_00730 :
-----------------	-------------------------

Container Name	ComTimeBase
Description	Contains the timebase parameters for Tx, Rx and routing.
Configuration Parameters	

SWS Item	ECUC_Com_00729 :		
Name	ComGwTimeBase		
Parent Container	ComTimeBase		
Description	<p>The period between successive calls to Com_MainFunctionRouteSignals in seconds. This parameter may be used by the COM generator to transform the values of the signal gateway related timing configuration parameters of the COM module to internal implementation specific counter or tick values. The COM module's internal timing handling is implementation specific.</p> <p>The COM module (generator) might rely on the fact that Com_MainFunctionRouteSignals is scheduled according to the value configured here.</p>		
Multiplicity	0..1		
Type	EcucFloatParamDef		
Range]0 .. INF[
Default value	--		
Post-Build Variant Multiplicity	false		
Post-Build Variant Value	false		
Multiplicity Configuration Class	Pre-compile time	X	VARIANT-PRE-COMPILE
	Link time	X	VARIANT-LINK-TIME, VARIANT-POST-BUILD
	Post-build time	--	
Value Configuration Class	Pre-compile time	X	VARIANT-PRE-COMPILE
	Link time	X	VARIANT-LINK-TIME, VARIANT-POST-BUILD
	Post-build time	--	
Scope / Dependency	scope: ECU		

SWS Item	ECUC_Com_00728 :		
Name	ComRxTimeBase		
Parent Container	ComTimeBase		
Description	<p>The period between successive calls to Com_MainFunctionRx in seconds. This parameter may be used by the COM generator to transform the values of the reception related timing configuration parameters of the COM module to internal implementation specific counter or tick values. The COM module's internal timing handling is implementation specific.</p> <p>The COM module (generator) may rely on the fact that Com_MainFunctionRx is scheduled according to the value configured here.</p>		
Multiplicity	0..1		
Type	EcucFloatParamDef		
Range]0 .. INF[
Default value	--		
Post-Build Variant Multiplicity	false		
Post-Build Variant Value	false		
Multiplicity Configuration Class	Pre-compile time	X	VARIANT-PRE-COMPILE
	Link time	X	VARIANT-LINK-TIME, VARIANT-POST-BUILD
	Post-build time	--	
Value Configuration Class	Pre-compile time	X	VARIANT-PRE-COMPILE
	Link time	X	VARIANT-LINK-TIME, VARIANT-POST-BUILD

			BUILD
	Post-build time	--	
Scope / Dependency	scope: ECU		

SWS Item	ECUC_Com_00186 :		
Name	ComTxTimeBase		
Parent Container	ComTimeBase		
Description	The period between successive calls to Com_MainFunctionTx in seconds. This parameter may be used by the COM generator to transform the values of the transmission related timing configuration parameters of the COM module to internal implementation specific counter or tick values. The COM module's internal timing handling is implementation specific. The COM module (generator) may rely on the fact that Com_MainFunctionTx is scheduled according to the value configured here.		
Multiplicity	0..1		
Type	EcucFloatParamDef		
Range]0 .. INF[
Default value	--		
Post-Build Variant Multiplicity	false		
Post-Build Variant Value	false		
Multiplicity Configuration Class	Pre-compile time	X	VARIANT-PRE-COMPILE
	Link time	X	VARIANT-LINK-TIME, VARIANT-POST-BUILD
	Post-build time	--	
Value Configuration Class	Pre-compile time	X	VARIANT-PRE-COMPILE
	Link time	X	VARIANT-LINK-TIME, VARIANT-POST-BUILD
	Post-build time	--	
Scope / Dependency	scope: ECU		

No Included Containers

10.1.6 ComFilter

SWS Item	ECUC_Com_00339 :		
Container Name	ComFilter		
Description	This container contains the configuration parameters of the AUTOSAR COM module's Filters. Note: On sender side the container is used to specify the transmission mode conditions.		
Configuration Parameters			

SWS Item	ECUC_Com_00146 :		
Name	ComFilterAlgorithm		
Parent Container	ComFilter		
Description	The range of values is specified in the [17] specification, chapter 2.2.2, Reception Filtering.		
Multiplicity	1		
Type	EcucEnumerationParamDef		
Range	ALWAYS	--	
	MASKED_NEW_DIFFERS_MASKED_OLD	--	
	MASKED_NEW_DIFFERS_X	--	

	MASKED_NEW_EQUALS_X	--	
	NEVER	--	
	NEW_IS_OUTSIDE	--	
	NEW_IS_WITHIN	--	
	ONE EVERY_N	--	
Post-Build Variant Value	false		
Value Configuration Class	Pre-compile time	X	VARIANT-PRE-COMPILE
	Link time	X	VARIANT-LINK-TIME, VARIANT-POST-BUILD
	Post-build time	--	
Scope / Dependency	scope: local		

SWS Item	ECUC_Com_00235 :		
Name	ComFilterMask		
Parent Container	ComFilter		
Description	The name of this attribute corresponds to the parameter name in the [17] specification of Reception Filtering.		
Multiplicity	0..1		
Type	EcucIntegerParamDef		
Range	-2147483648 .. 4294967295		
Default value	--		
Post-Build Variant Multiplicity	false		
Post-Build Variant Value	false		
Multiplicity Configuration Class	Pre-compile time	X	VARIANT-PRE-COMPILE
	Link time	X	VARIANT-LINK-TIME, VARIANT-POST-BUILD
	Post-build time	--	
Value Configuration Class	Pre-compile time	X	VARIANT-PRE-COMPILE
	Link time	X	VARIANT-LINK-TIME, VARIANT-POST-BUILD
	Post-build time	--	
Scope / Dependency	scope: local		

SWS Item	ECUC_Com_00317 :		
Name	ComFilterMax		
Parent Container	ComFilter		
Description	The name of this attribute corresponds to the parameter name in the [17] specification of Reception Filtering.		
Multiplicity	0..1		
Type	EcucIntegerParamDef		
Range	-2147483648 .. 4294967295		
Default value	--		
Post-Build Variant Multiplicity	false		
Post-Build Variant Value	false		
Multiplicity Configuration Class	Pre-compile time	X	VARIANT-PRE-COMPILE
	Link time	X	VARIANT-LINK-TIME, VARIANT-POST-BUILD
	Post-build time	--	
Value Configuration Class	Pre-compile time	X	VARIANT-PRE-COMPILE
	Link time	X	VARIANT-LINK-TIME, VARIANT-POST-BUILD

			BUILD
	Post-build time	--	
Scope / Dependency	scope: local		

SWS Item	ECUC_Com_00318 :		
Name	ComFilterMin		
Parent Container	ComFilter		
Description	The name of this attribute corresponds to the parameter name in the [17] specification of Reception Filtering.		
Multiplicity	0..1		
Type	EcuIntegerParamDef		
Range	-2147483648 .. 4294967295		
Default value	--		
Post-Build Variant Multiplicity	false		
Post-Build Variant Value	false		
Multiplicity Configuration Class	Pre-compile time	X	VARIANT-PRE-COMPILE
	Link time	X	VARIANT-LINK-TIME, VARIANT-POST-BUILD
	Post-build time	--	
Value Configuration Class	Pre-compile time	X	VARIANT-PRE-COMPILE
	Link time	X	VARIANT-LINK-TIME, VARIANT-POST-BUILD
	Post-build time	--	
Scope / Dependency	scope: local		

SWS Item	ECUC_Com_00313 :		
Name	ComFilterOffset		
Parent Container	ComFilter		
Description	The name of this attribute corresponds to the parameter name in the [17] specification of Reception Filtering. Range = 0..(ComFilterPeriod-1)		
Multiplicity	0..1		
Type	EcuIntegerParamDef		
Range	0 .. 4294967294		
Default value	--		
Post-Build Variant Multiplicity	false		
Post-Build Variant Value	false		
Multiplicity Configuration Class	Pre-compile time	X	VARIANT-PRE-COMPILE
	Link time	X	VARIANT-LINK-TIME, VARIANT-POST-BUILD
	Post-build time	--	
Value Configuration Class	Pre-compile time	X	VARIANT-PRE-COMPILE
	Link time	X	VARIANT-LINK-TIME, VARIANT-POST-BUILD
	Post-build time	--	
Scope / Dependency	scope: local dependency: ECUC_Com_00312		

SWS Item	ECUC_Com_00312 :		
Name	ComFilterPeriod		
Parent Container	ComFilter		
Description	This parameter defines the period of the ComFilterAlgorithm ONE_EVERY_N.		

Multiplicity	0..1		
Type	EcucIntegerParamDef		
Range	2 .. 4294967295		
Default value	--		
Post-Build Variant Multiplicity	true		
Post-Build Variant Value	true		
Multiplicity Configuration Class	Pre-compile time	X	VARIANT-PRE-COMPILE
	Link time	X	VARIANT-LINK-TIME
	Post-build time	X	VARIANT-POST-BUILD
Value Configuration Class	Pre-compile time	X	VARIANT-PRE-COMPILE
	Link time	X	VARIANT-LINK-TIME
	Post-build time	X	VARIANT-POST-BUILD
Scope / Dependency	scope: local		

SWS Item	ECUC_Com_00147 :		
Name	ComFilterX		
Parent Container	ComFilter		
Description	The name of this attribute corresponds to the parameter name in the [17] specification of Reception Filtering.		
Multiplicity	0..1		
Type	EcucIntegerParamDef		
Range	-2147483648 .. 4294967295		
Default value	--		
Post-Build Variant Multiplicity	false		
Post-Build Variant Value	false		
Multiplicity Configuration Class	Pre-compile time	X	VARIANT-PRE-COMPILE
	Link time	X	VARIANT-LINK-TIME, VARIANT-POST-BUILD
	Post-build time	--	
Value Configuration Class	Pre-compile time	X	VARIANT-PRE-COMPILE
	Link time	X	VARIANT-LINK-TIME, VARIANT-POST-BUILD
	Post-build time	--	
Scope / Dependency	scope: local		

No Included Containers

10.1.7 ComIPdu

SWS Item	ECUC_Com_00340 :		
Container Name	ComIPdu		
Description	Contains the configuration parameters of the AUTOSAR COM module's I-PDUs.		
Post-Build Variant Multiplicity	true		
Multiplicity Configuration Class	Pre-compile time	X	VARIANT-PRE-COMPILE
	Link time	X	VARIANT-LINK-TIME
	Post-build time	X	VARIANT-POST-BUILD
Configuration Parameters			

SWS Item	ECUC_Com_00387 :		
Name	ComIPduCallout		
Parent Container	ComIPdu		
Description	This parameter defines the existence and the name of a callout function for the corresponding I-PDU. If this parameter is omitted no I-PDU callout shall take place for the corresponding I-PDU.		
Multiplicity	0..1		
Type	EcucFunctionNameDef		
Default value	--		
maxLength	--		
minLength	--		
regularExpression	--		
Post-Build Variant Multiplicity	false		
Post-Build Variant Value	false		
Multiplicity Configuration Class	Pre-compile time	X	All Variants
	Link time	--	
	Post-build time	--	
Value Configuration Class	Pre-compile time	X	All Variants
	Link time	--	
	Post-build time	--	
Scope / Dependency	scope: local		

SWS Item	ECUC_Com_00709 :		
Name	ComIPduCancellationSupport		
Parent Container	ComIPdu		
Description	Defines for I-PDUs with ComIPduType NORMAL: If the underlying IF-modul supports cancellation of transmit requests. Defines for I-PDUs with ComIPduType TP: If the underlying TP-module supports RX and TX cancellation of ongoing requests.		
Multiplicity	0..1		
Type	EcucBooleanParamDef		
Default value	false		
Post-Build Variant Multiplicity	true		
Post-Build Variant Value	true		
Multiplicity Configuration Class	Pre-compile time	X	VARIANT-PRE-COMPILE
	Link time	--	
	Post-build time	X	VARIANT-POST-BUILD
Value Configuration Class	Pre-compile time	X	VARIANT-PRE-COMPILE
	Link time	--	
	Post-build time	X	VARIANT-POST-BUILD
Scope / Dependency	scope: ECU dependency: This parameter shall not be set to true if ComCancellationSupport is set to false		

SWS Item	ECUC_Com_00493 :		
Name	ComIPduDirection		
Parent Container	ComIPdu		
Description	The direction defines if this I-PDU, and therefore the contributing signals and signal groups, shall be sent or received.		
Multiplicity	1		
Type	EcucEnumerationParamDef		
Range	RECEIVE	--	
	SEND	--	
Post-Build Variant	false		

Value			
Value Configuration Class	Pre-compile time	X	VARIANT-PRE-COMPILE
	Link time	X	VARIANT-LINK-TIME, VARIANT-POST-BUILD
	Post-build time	--	
Scope / Dependency	scope: local dependency: If configured to Sent also a ComTxIpdu container shall be included, see ECUC_Com_00496		

SWS Item	ECUC_Com_00175 :		
Name	ComIPduHandleId		
Parent Container	ComIPdu		
Description	The numerical value used as the ID of this I-PDU. The ComIPduHandleId is required by the API calls Com_RxIndication, Com_TpRxIndication, Com_StartOfReception and Com_CopyRxData to receive I-PDUs from the PduR (ComIP-duDirection: Receive), as well as the PduId passed to an Rx-I-PDU-callout. For Tx-I-PDUs (ComIPduDirection: Send), this handle Id is used for the APIs calls Com_TxConfirmation, Com_TriggerTransmit, Com_TriggerIPDUSend or Com_TriggerIPDUSendWithMetaData, Com_CopyTxData and Com_TpTxConfirmation to transmit respectively confirm transmissions of I-PDUs, as well as the PduId passed to the Tx-I-PDU-callout configured with ComIPduCallout and/or ComIPduTriggerTransmitCallout.		
Multiplicity	0..1		
Type	EcucIntegerParamDef (Symbolic Name generated for this parameter)		
Range	0 .. 65535		
Default value	--		
Post-Build Variant Multiplicity	false		
Post-Build Variant Value	false		
Value Configuration Class	Pre-compile time	X	All Variants
	Link time	--	
	Post-build time	--	
Value Configuration Class	Pre-compile time	X	All Variants
	Link time	--	
	Post-build time	--	
Scope / Dependency	scope: ECU		

SWS Item	ECUC_Com_00119 :		
Name	ComIPduSignalProcessing		
Parent Container	ComIPdu		
Description	For the definition of the two modes Immediate and Deferred.		
Multiplicity	1		
Type	EcucEnumerationParamDef		
Range	DEFERRED	signal indication / confirmations are deferred for example to a cyclic task	
	IMMEDIATE	the signal indications / confirmations are performed in Com_RxIndication/ Com_TxConfirmation	
Post-Build Variant Value	true		
Value Configuration Class	Pre-compile time	X	VARIANT-PRE-COMPILE
	Link time	X	VARIANT-LINK-TIME
	Post-build time	X	VARIANT-POST-BUILD
Scope / Dependency	scope: local		

SWS Item	ECUC_Com_00765 :		
Name	ComIPduTriggerTransmitCallout		
Parent Container	ComIPdu		
Description	If there is a trigger transmit callout defined for this I-PDU this parameter contains the name of the callout function.		
Multiplicity	0..1		
Type	EcucFunctionNameDef		
Default value	--		
maxLength	--		
minLength	--		
regularExpression	--		
Post-Build Variant Multiplicity	false		
Post-Build Variant Value	false		
Multiplicity Configuration Class	Pre-compile time	X	All Variants
	Link time	--	
	Post-build time	--	
Value Configuration Class	Pre-compile time	X	All Variants
	Link time	--	
	Post-build time	--	
Scope / Dependency	scope: local		

SWS Item	ECUC_Com_00761 :		
Name	ComIPduType		
Parent Container	ComIPdu		
Description	Defines if this I-PDU is a normal I-PDU that can be sent unfragmented or if this is a large I-PDU that shall be sent via the Transport Protocol of the underlying bus.		
Multiplicity	1		
Type	EcucEnumerationParamDef		
Range	NORMAL		sent or received via normal L-PDU
	TP		sent or received via TP
Post-Build Variant Value	true		
Value Configuration Class	Pre-compile time	X	VARIANT-PRE-COMPILE
	Link time	X	VARIANT-LINK-TIME
	Post-build time	X	VARIANT-POST-BUILD
Scope / Dependency	scope: local		

SWS Item	ECUC_Com_00206 :		
Name	ComIPduGroupRef		
Parent Container	ComIPdu		
Description	Reference to the I-PDU groups this I-PDU belongs to.		
Multiplicity	0..*		
Type	Reference to [ComIPduGroup]		
Post-Build Variant Multiplicity	true		
Post-Build Variant Value	true		
Multiplicity Configuration Class	Pre-compile time	X	VARIANT-PRE-COMPILE
	Link time	X	VARIANT-LINK-TIME
	Post-build time	X	VARIANT-POST-BUILD
Value Configuration Class	Pre-compile time	X	VARIANT-PRE-COMPILE
	Link time	X	VARIANT-LINK-TIME
	Post-build time	X	VARIANT-POST-BUILD
Scope / Dependency	scope: local		

SWS Item	ECUC_Com_00519 :		
Name	ComIPduSignalGroupRef		
Parent Container	ComIPdu		
Description	References to all signal groups contained in this I-Pdu		
Multiplicity	0..*		
Type	Reference to [ComSignalGroup]		
Post-Build Variant Multiplicity	true		
Post-Build Variant Value	true		
Multiplicity Configuration Class	Pre-compile time	X	VARIANT-PRE-COMPILE
	Link time	X	VARIANT-LINK-TIME
	Post-build time	X	VARIANT-POST-BUILD
Value Configuration Class	Pre-compile time	X	VARIANT-PRE-COMPILE
	Link time	X	VARIANT-LINK-TIME
	Post-build time	X	VARIANT-POST-BUILD
Scope / Dependency	scope: local		

SWS Item	ECUC_Com_00518 :		
Name	ComIPduSignalRef		
Parent Container	ComIPdu		
Description	References to all signals contained in this I-PDU.		
Multiplicity	0..*		
Type	Reference to [ComSignal]		
Post-Build Variant Multiplicity	true		
Post-Build Variant Value	true		
Multiplicity Configuration Class	Pre-compile time	X	VARIANT-PRE-COMPILE
	Link time	X	VARIANT-LINK-TIME
	Post-build time	X	VARIANT-POST-BUILD
Value Configuration Class	Pre-compile time	X	VARIANT-PRE-COMPILE
	Link time	X	VARIANT-LINK-TIME
	Post-build time	X	VARIANT-POST-BUILD
Scope / Dependency	scope: local		

SWS Item	ECUC_Com_00711 :		
Name	ComPduIdRef		
Parent Container	ComIPdu		
Description	Reference to the "global" Pdu structure to allow harmonization of handle IDs in the COM-Stack.		
Multiplicity	1		
Type	Reference to [Pdu]		
Post-Build Variant Value	false		
Value Configuration Class	Pre-compile time	X	VARIANT-PRE-COMPILE
	Link time	X	VARIANT-LINK-TIME, VARIANT-POST-BUILD
	Post-build time	--	
Scope / Dependency			

Included Containers		
Container Name	Multiplicity	Scope / Dependency
ComIPduCounter	0..1	This optional container contains the configuration parameters of PDU Counter.
ComIPduReplication	0..1	This optional container contains the information needed for each I-PDU replicated.
ComTxIPdu	0..1	This container must be included if COM_IPDU_DIRECTION is configured to SEND.

[SWS_Com_00497] [A ComTxIPdu container must be included if ComIPduDirection is configured to SEND.] (SRS_BSW_00167)

10.1.8 ComIPduCounter

SWS Item	ECUC_Com_00592 :
Container Name	ComIPduCounter
Description	This optional container contains the configuration parameters of PDU Counter.
Configuration Parameters	

SWS Item	ECUC_Com_00003 :		
Name	ComIPduCounterErrorNotification		
Parent Container	ComIPduCounter		
Description	Name of Com_CbkCounterErr callback function to be called. If this parameter is omitted no I-PDU counter mismatch notification shall take place.		
Multiplicity	0..1		
Type	EcucFunctionNameDef		
Default value	--		
maxLength	--		
minLength	--		
regularExpression	--		
Post-Build Variant Multiplicity	false		
Post-Build Variant Value	false		
Multiplicity Configuration Class	Pre-compile time	X	VARIANT-PRE-COMPILE
	Link time	X	VARIANT-LINK-TIME, VARIANT-POST-BUILD
	Post-build time	--	
Value Configuration Class	Pre-compile time	X	VARIANT-PRE-COMPILE
	Link time	X	VARIANT-LINK-TIME, VARIANT-POST-BUILD
	Post-build time	--	
Scope / Dependency	scope: local		

SWS Item	ECUC_Com_00593 :		
Name	ComIPduCounterSize		
Parent Container	ComIPduCounter		
Description	Size of PDU Counter expressed in bits		
Multiplicity	1		
Type	EcucIntegerParamDef		
Range	1 .. 8		
Default value	--		
Post-Build Variant Value	false		
Value Configuration Class	Pre-compile time	X	All Variants
	Link time	--	
	Post-build time	--	
Scope / Dependency	scope: local		

SWS Item	ECUC_Com_00594 :		
Name	ComIPduCounterStartPosition		
Parent Container	ComIPduCounter		

Description	Position of PDU counter expressed in bits from start position of data content of I-PDU (SDU). Note that PDU counter is not allowed to cross a byte border. The parameter ComIPduCounterStartPosition shall define the bit0 of the first byte like in little endian byte order.		
Multiplicity	1		
Type	EcuIntegerParamDef		
Range	0 .. 4294967295		
Default value	--		
Post-Build Variant Value	false		
Value Configuration Class	Pre-compile time	X	All Variants
	Link time	--	
	Post-build time	--	
Scope / Dependency	scope: local		

SWS Item	ECUC_Com_00595 :		
Name	ComIPduCounterThreshold		
Parent Container	ComIPduCounter		
Description	Threshold value of I-PDU counter algorithm, see ECUC_Com_00590.		
Multiplicity	0..1		
Type	EcuIntegerParamDef		
Range	0 .. 255		
Default value	0		
Post-Build Variant Multiplicity	false		
Post-Build Variant Value	false		
Multiplicity Configuration Class	Pre-compile time	X	All Variants
	Link time	--	
	Post-build time	--	
Value Configuration Class	Pre-compile time	X	All Variants
	Link time	--	
	Post-build time	--	
Scope / Dependency	scope: local		

No Included Containers

10.1.9 ComIPduReplication

SWS Item	ECUC_Com_00599 :		
Container Name	ComIPduReplication		
Description	This optional container contains the information needed for each I-PDU replicated.		
Configuration Parameters			

SWS Item	ECUC_Com_00600 :		
Name	ComIPduReplicationQuorum		
Parent Container	ComIPduReplication		
Description	The number of identical I-PDUs needed for successful voting.		
Multiplicity	1		
Type	EcuIntegerParamDef		
Range	1 .. 3		

Default value	--		
Post-Build Variant Value	false		
Value Configuration Class	Pre-compile time	X	All Variants
	Link time	--	
	Post-build time	--	
Scope / Dependency	scope: local dependency: This value must be less or equal to the multiplicity of (ComIPduReplicaRef + 1).		

SWS Item	ECUC_Com_00601 :		
Name	ComIPduReplicaRef		
Parent Container	ComIPduReplication		
Description	Reference to replicas PduR PDUs of this IPDU.		
Multiplicity	1..2		
Type	Reference to [Pdu]		
Post-Build Variant Multiplicity	false		
Post-Build Variant Value	false		
Multiplicity Configuration Class	Pre-compile time	X	All Variants
	Link time	--	
	Post-build time	--	
Value Configuration Class	Pre-compile time	X	All Variants
	Link time	--	
	Post-build time	--	
Scope / Dependency	scope: ECU		

No Included Containers

10.1.10 ComTxIPdu

SWS Item	ECUC_Com_00496 :
Container Name	ComTxIPdu
Description	This container contains additional transmission related configuration parameters of the AUTOSAR COM module's I-PDUs.
Configuration Parameters	

SWS Item	ECUC_Com_10005 :
Name	ComMetaDataDefault
Parent Container	ComTxIPdu
Description	In case an I-PDU refers to a globally configured MetaDataType and no explicit meta data is given for a send request (e.g. by using Com_TriggerIPDUSendWithMetaData), the AUTOSAR COM module uses this configured default meta data for sending. The configured string shall be interpreted as a decimal representation of the characters separated by blanks, e.g. "97 98 100" means a string "abd", where the char "a" is in byte 0(lowest address), "b" is in byte 1, and "d" is in byte 2 and (highest address).
Multiplicity	0..1
Type	EcucStringParamDef
Default value	--
maxLength	--
minLength	--
regularExpression	--

Post-Build Variant Multiplicity	false		
Post-Build Variant Value	false		
Multiplicity Configuration Class	Pre-compile time	X	All Variants
	Link time	--	
	Post-build time	--	
Value Configuration Class	Pre-compile time	X	VARIANT-PRE-COMPILE
	Link time	X	VARIANT-LINK-TIME, VARIANT-POST-BUILD
	Post-build time	--	
Scope / Dependency	scope: ECU dependency: This parameter shall only be used in case ComMetaDataSupport is enabled. The length of the default meta data shall match the globally configured MetaDataLength of this I-PDU.		

SWS Item	ECUC_Com_00181 :		
Name	ComMinimumDelayTime		
Parent Container	ComTxIPdu		
Description	Defines the Minimum Delay Time (MDT) between successive transmissions of this I-PDU in seconds. The MDT is independent of the possible different transmission modes. There is only one minimum delay time parameter for one I-PDU. The minimum delay timer is not reset by changing the transmission mode. Hence, it is not allowed to violate the minimum delay time by transmission mode changes. It is not possible to monitor the minimum delay time for I-PDUs that are requested using the Com_TriggerTransmit API.		
Multiplicity	0..1		
Type	EcucFloatParamDef		
Range	[0 .. 3600]		
Default value	--		
Post-Build Variant Multiplicity	true		
Post-Build Variant Value	true		
Multiplicity Configuration Class	Pre-compile time	X	VARIANT-PRE-COMPILE
	Link time	X	VARIANT-LINK-TIME
	Post-build time	X	VARIANT-POST-BUILD
Value Configuration Class	Pre-compile time	X	VARIANT-PRE-COMPILE
	Link time	X	VARIANT-LINK-TIME
	Post-build time	X	VARIANT-POST-BUILD
Scope / Dependency	scope: local		

SWS Item	ECUC_Com_00576 :		
Name	ComTxIPduClearUpdateBit		
Parent Container	ComTxIPdu		
Description	Defines when the update-bits of signals or signal groups, contained in this I-PDU, will be cleared.		
Multiplicity	0..1		
Type	EcucEnumerationParamDef		
Range	Confirmation		The update-bits are cleared when the transmission of the I-PDU was confirmed. In case of Direct/N-Times transmission mode the update bits will be cleared with respect to the confirmation behaviour of SWS_Com_00305.
	Transmit		The update-bits are cleared directly after the invocation of PduR_ComTransmit.
	TriggerTransmit		The update-bits are cleared after the I-PDU

		was fetched via Com_TriggerTransmit.	
Post-Build Variant Multiplicity	true		
Post-Build Variant Value	true		
Multiplicity Configuration Class	Pre-compile time	X	VARIANT-PRE-COMPILE
	Link time	X	VARIANT-LINK-TIME
	Post-build time	X	VARIANT-POST-BUILD
Value Configuration Class	Pre-compile time	X	VARIANT-PRE-COMPILE
	Link time	X	VARIANT-LINK-TIME
	Post-build time	X	VARIANT-POST-BUILD
Scope / Dependency	scope: local		

SWS Item	ECUC_Com_00017 :		
Name	ComTxIPduUnusedAreasDefault		
Parent Container	ComTxIPdu		
Description	The AUTOSAR COM module fills not used areas of an I-PDU with this byte pattern. This attribute is mandatory to avoid undefined behaviour. This byte-pattern will be repeated throughout the I-PDU before any init-values or update-bits were set.		
Multiplicity	1		
Type	EcucIntegerParamDef		
Range	0 .. 255		
Default value	--		
Post-Build Variant Value	false		
Value Configuration Class	Pre-compile time	X	VARIANT-PRE-COMPILE
	Link time	X	VARIANT-LINK-TIME, VARIANT-POST-BUILD
	Post-build time	--	
Scope / Dependency	scope: local		

Included Containers		
Container Name	Multiplicity	Scope / Dependency
ComTxModeFalse	0..1	The referenced transmission mode object that is used when the filtering state for this I-PDU evaluates to false. The default is transmission mode None.
ComTxModeTrue	0..1	The referenced transmission mode object that is used when the filtering state for this I-PDU evaluates to true.

10.1.11 ComIPduGroup

SWS Item	ECUC_Com_00341 :		
Container Name	ComIPduGroup		
Description	Contains the configuration parameters of the AUTOSAR COM module's I-PDU groups.		
Post-Build Variant Multiplicity	true		
Multiplicity Configuration Class	Pre-compile time	X	VARIANT-PRE-COMPILE
	Link time	X	VARIANT-LINK-TIME
	Post-build time	X	VARIANT-POST-BUILD
Configuration Parameters			

SWS Item	ECUC_Com_00184 :		
Name	ComIPduGroupHandleId		
Parent Container	ComIPduGroup		
Description	The numerical value used as the ID of this I-PDU Group . The ComIPduGroupHandleId is required by the API calls to start and stop I-PDU Groups. Range: 0 .. (ComSupportedIPduGroups-1)		
Multiplicity	1		
Type	EcucIntegerParamDef (Symbolic Name generated for this parameter)		
Range	0 .. 65535		
Default value	--		
Post-Build Variant Value	false		
Value Configuration Class	Pre-compile time	X	All Variants
	Link time	--	
	Post-build time	--	
Scope / Dependency	scope: ECU		

SWS Item	ECUC_Com_00185 :		
Name	ComIPduGroupGroupRef		
Parent Container	ComIPduGroup		
Description	References to all I-PDU groups that includes this I-PDU group. If this reference is omitted this I-PDU group does not belong to another I-PDU group.		
Multiplicity	0..*		
Type	Reference to [ComIPduGroup]		
Post-Build Variant Multiplicity	true		
Post-Build Variant Value	true		
Multiplicity Configuration Class	Pre-compile time	X	VARIANT-PRE-COMPILE
	Link time	X	VARIANT-LINK-TIME
	Post-build time	X	VARIANT-POST-BUILD
Value Configuration Class	Pre-compile time	X	VARIANT-PRE-COMPILE
	Link time	X	VARIANT-LINK-TIME
	Post-build time	X	VARIANT-POST-BUILD
Scope / Dependency	scope: local		

No Included Containers

10.1.12 ComSignal

SWS Item	ECUC_Com_00344 :		
Container Name	ComSignal		
Description	Contains the configuration parameters of the AUTOSAR COM module's signals.		
Post-Build Variant Multiplicity	true		
Multiplicity Configuration Class	Pre-compile time	X	VARIANT-PRE-COMPILE
	Link time	X	VARIANT-LINK-TIME
	Post-build time	X	VARIANT-POST-BUILD
Configuration Parameters			

SWS Item	ECUC_Com_00259 :		
-----------------	-------------------------	--	--

Name	ComBitPosition		
Parent Container	ComSignal		
Description	Starting position within the I-PDU. This parameter refers to the position in the I-PDU and not in the shadow buffer. If the endianness conversion is configured to Opaque the parameter ComBitPosition shall define the bit0 of the first byte like in little endian byte order		
Multiplicity	1		
Type	EcucIntegerParamDef		
Range	0 .. 4294967295		
Default value	--		
Post-Build Variant Value	true		
Value Configuration Class	Pre-compile time	X	VARIANT-PRE-COMPILE
	Link time	X	VARIANT-LINK-TIME
	Post-build time	X	VARIANT-POST-BUILD
Scope / Dependency	scope: local		

SWS Item	ECUC_Com_00158 :		
Name	ComBitSize		
Parent Container	ComSignal		
Description	Size in bits, for integer signal types. For ComSignalType UINT8_N and UINT8_DYN the size shall be configured by ComSignalLength. For ComSignalTypes FLOAT32 and FLOAT64 the size is already defined by the signal type and therefore may be omitted.		
Multiplicity	0..1		
Type	EcucIntegerParamDef		
Range	0 .. 64		
Default value	--		
Post-Build Variant Multiplicity	true		
Post-Build Variant Value	true		
Multiplicity Configuration Class	Pre-compile time	X	VARIANT-PRE-COMPILE
	Link time	X	VARIANT-LINK-TIME
	Post-build time	X	VARIANT-POST-BUILD
Value Configuration Class	Pre-compile time	X	VARIANT-PRE-COMPILE
	Link time	X	VARIANT-LINK-TIME
	Post-build time	X	VARIANT-POST-BUILD
Scope / Dependency	scope: local		

SWS Item	ECUC_Com_00314 :		
Name	ComDataInvalidAction		
Parent Container	ComSignal		
Description	This parameter defines the action performed upon reception of an invalid signal. Relating to signal groups the action in case if one of the included signals is an invalid signal. If Replace is used the ComSignalInitValue will be used for the replacement.		
Multiplicity	0..1		
Type	EcucEnumerationParamDef		
Range	NOTIFY		--
	REPLACE		Literal for DataInvalidAction
Post-Build Variant Multiplicity	false		
Post-Build Variant Value	false		
Multiplicity Configuration Class	Pre-compile time	X	VARIANT-PRE-COMPILE

Duration Class	Link time	X	VARIANT-LINK-TIME, VARIANT-POST-BUILD
	Post-build time	--	
Value Configuration Class	Pre-compile time	X	VARIANT-PRE-COMPILE
	Link time	X	VARIANT-LINK-TIME, VARIANT-POST-BUILD
	Post-build time	--	
Scope / Dependency	scope: local		

SWS Item	ECUC_Com_00499 :		
Name	ComErrorNotification		
Parent Container	ComSignal		
Description	Only valid on sender side: Name of Com_CbkTxErr callback function to be called. If this parameter is omitted no error notification shall take place.		
Multiplicity	0..1		
Type	EcucFunctionNameDef		
Default value	--		
maxLength	--		
minLength	--		
regularExpression	--		
Post-Build Variant Multiplicity	false		
Post-Build Variant Value	false		
Multiplicity Configuration Class	Pre-compile time	X	VARIANT-PRE-COMPILE
	Link time	X	VARIANT-LINK-TIME, VARIANT-POST-BUILD
	Post-build time	--	
Value Configuration Class	Pre-compile time	X	VARIANT-PRE-COMPILE
	Link time	X	VARIANT-LINK-TIME, VARIANT-POST-BUILD
	Post-build time	--	
Scope / Dependency	scope: local		

SWS Item	ECUC_Com_00183 :		
Name	ComFirstTimeout		
Parent Container	ComSignal		
Description	Defines the length of the first deadline monitoring timeout period in seconds. This timeout is used immediately after start (or restart) of the deadline monitoring service. The timeout period of the successive periods is configured by ECUC_Com_00263.		
Multiplicity	0..1		
Type	EcucFloatParamDef		
Range	[0 .. 3600]		
Default value	--		
Post-Build Variant Multiplicity	true		
Post-Build Variant Value	true		
Multiplicity Configuration Class	Pre-compile time	X	VARIANT-PRE-COMPILE
	Link time	X	VARIANT-LINK-TIME
	Post-build time	X	VARIANT-POST-BUILD
Value Configuration Class	Pre-compile time	X	VARIANT-PRE-COMPILE
	Link time	X	VARIANT-LINK-TIME
	Post-build time	X	VARIANT-POST-BUILD
Scope / Dependency	scope: local		

SWS Item	ECUC_Com_00165 :		
Name	ComHandleId		
Parent Container	ComSignal		
Description	The numerical value used as the ID. This ID identifies signals and signal groups in the COM APIs using Com_SignalIdType or Com_SignalGroupIdType parameter respectively.		
Multiplicity	0..1		
Type	EcucIntegerParamDef (Symbolic Name generated for this parameter)		
Range	0 .. 65535		
Default value	--		
Post-Build Variant Multiplicity	false		
Post-Build Variant Value	false		
Multiplicity Configuration Class	Pre-compile time	X	All Variants
	Link time	--	
	Post-build time	--	
Value Configuration Class	Pre-compile time	X	All Variants
	Link time	--	
	Post-build time	--	
Scope / Dependency	scope: ECU		

SWS Item	ECUC_Com_00811 :		
Name	ComInitialValueOnly		
Parent Container	ComSignal		
Description	This parameter defines that the respective signal's initial value shall be put into the respective PDU but there will not be any update of the value through the RTE. Thus the Com implementation does not need to expect any API calls for this signal (group).		
Multiplicity	0..1		
Type	EcucBooleanParamDef		
Default value	false		
Post-Build Variant Multiplicity	false		
Post-Build Variant Value	false		
Multiplicity Configuration Class	Pre-compile time	X	VARIANT-PRE-COMPILE
	Link time	X	VARIANT-LINK-TIME, VARIANT-POST-BUILD
	Post-build time	--	
Value Configuration Class	Pre-compile time	X	VARIANT-PRE-COMPILE
	Link time	X	VARIANT-LINK-TIME, VARIANT-POST-BUILD
	Post-build time	--	
Scope / Dependency	scope: local		

SWS Item	ECUC_Com_00315 :		
Name	ComInvalidNotification		
Parent Container	ComSignal		
Description	Only valid on receiver side: Name of Com_CbkInv callback function to be called. Name of the function which notifies the RTE about the reception of an invalidated signal/ signal group. Only applicable if ComDataInvalidAction is configured to NOTIFY.		
Multiplicity	0..1		
Type	EcucFunctionNameDef		
Default value	--		
maxLength	--		

minLength	--		
regularExpression	--		
Post-Build Variant Multiplicity	false		
Post-Build Variant Value	false		
Multiplicity Configuration Class	Pre-compile time	X	VARIANT-PRE-COMPILE
	Link time	X	VARIANT-LINK-TIME, VARIANT-POST-BUILD
	Post-build time	--	
Value Configuration Class	Pre-compile time	X	VARIANT-PRE-COMPILE
	Link time	X	VARIANT-LINK-TIME, VARIANT-POST-BUILD
	Post-build time	--	
Scope / Dependency	scope: local		

SWS Item	ECUC_Com_00498 :		
Name	ComNotification		
Parent Container	ComSignal		
Description	On sender side: Name of Com_CbkTxAck callback function to be called. On receiver side: Name of Com_CbkRxAck callback function to be called. If this parameter is omitted no notification shall take place.		
Multiplicity	0..1		
Type	EcucFunctionNameDef		
Default value	--		
maxLength	--		
minLength	--		
regularExpression	--		
Post-Build Variant Multiplicity	false		
Post-Build Variant Value	false		
Multiplicity Configuration Class	Pre-compile time	X	VARIANT-PRE-COMPILE
	Link time	X	VARIANT-LINK-TIME, VARIANT-POST-BUILD
	Post-build time	--	
Value Configuration Class	Pre-compile time	X	VARIANT-PRE-COMPILE
	Link time	X	VARIANT-LINK-TIME, VARIANT-POST-BUILD
	Post-build time	--	
Scope / Dependency	scope: local		

SWS Item	ECUC_Com_00412 :		
Name	ComRxDataTimeoutAction		
Parent Container	ComSignal		
Description	This parameter defines the action performed upon expiration of the reception deadline monitoring timer.		
Multiplicity	0..1		
Type	EcucEnumerationParamDef		
Range	NONE	no replacement shall take place	
	REPLACE	signals shall be replaced by their ComSignalInitValue	
	SUBSTITUTE	signals shall be replaced by their ComTimeoutSubstitutionValue	
Post-Build Variant Multiplicity	false		
Post-Build Variant Value	false		

Value			
Multiplicity Configuration Class	Pre-compile time	X	VARIANT-PRE-COMPILE
	Link time	X	VARIANT-LINK-TIME, VARIANT-POST-BUILD
	Post-build time	--	
Value Configuration Class	Pre-compile time	X	VARIANT-PRE-COMPILE
	Link time	X	VARIANT-LINK-TIME, VARIANT-POST-BUILD
	Post-build time	--	
Scope / Dependency	scope: local		

SWS Item	ECUC_Com_00391 :		
Name	ComSignalDataInvalidValue		
Parent Container	ComSignal		
Description	<p>Defines the data invalid value of the signal.</p> <p>In case the ComSignalType is UINT8, UINT16, UINT32, UINT64, SINT8, SINT16, SINT32, SINT64 the string shall be interpreted as defined in the chapter Integer Type in the AUTOSAR EcuC specification.</p> <p>In case the ComSignalType is FLOAT32, FLOAT64 the string shall be interpreted as defined in the chapter Float Type in the AUTOSAR EcuC specification.</p> <p>In case the ComSignalType is BOOLEAN the string shall be interpreted as defined in the chapter Boolean Type in the AUTOSAR EcuC specification.</p> <p>In case the ComSignal is a UINT8_N, UINT8_DYN the string shall be interpreted as a decimal representation of the characters separated by blanks, e.g. "97 98 100" means a string "abd", where the char "a" is in byte 0(lowest address), "b" is in byte 1, and "d" is in byte 2 and (highest address).</p> <p>For the ComSignalType UINT8_DYN the dynamic length shall be set to the number of configured characters. An empty string "" shall be interpreted as 0-sized dynamic signal.</p>		
Multiplicity	0..1		
Type	EcucStringParamDef		
Default value	--		
maxLength	--		
minLength	--		
regularExpression	--		
Post-Build Variant Multiplicity	false		
Post-Build Variant Value	false		
Multiplicity Configuration Class	Pre-compile time	X	VARIANT-PRE-COMPILE
	Link time	X	VARIANT-LINK-TIME, VARIANT-POST-BUILD
	Post-build time	--	
Value Configuration Class	Pre-compile time	X	VARIANT-PRE-COMPILE
	Link time	X	VARIANT-LINK-TIME, VARIANT-POST-BUILD
	Post-build time	--	
Scope / Dependency	scope: local dependency: In case of UINT8_N the length of ComSignalDataInvalidValue has to be the same as ComSignalLength.		

SWS Item	ECUC_Com_00157 :		
Name	ComSignalEndianness		
Parent Container	ComSignal		
Description	Defines the endianness of the signal's network representation.		

Multiplicity	1		
Type	EcucEnumerationParamDef		
Range	BIG_ENDIAN	--	
	LITTLE_ENDIAN	--	
	OPAQUE	--	
Post-Build Variant Value	true		
Value Configuration Class	Pre-compile time	X	VARIANT-PRE-COMPILE
	Link time	X	VARIANT-LINK-TIME
	Post-build time	X	VARIANT-POST-BUILD
Scope / Dependency	scope: local		

SWS Item	ECUC_Com_00170 :		
Name	ComSignalInitValue		
Parent Container	ComSignal		
Description	<p>Initial value for this signal. In case of UINT8_N the default value is a string of length ComSignalLength with all bytes set to 0x00. In case of UINT8_DYN the initial size shall be 0.</p> <p>In case the ComSignalType is UINT8, UINT16, UINT32, UINT64, SINT8, SINT16, SINT32, SINT64 the string shall be interpreted as defined in the chapter Integer Type in the AUTOSAR EcuC specification.</p> <p>In case the ComSignalType is FLOAT32, FLOAT64 the string shall be interpreted as defined in the chapter Float Type in the AUTOSAR EcuC specification.</p> <p>In case the ComSignalType is BOOLEAN the string shall be interpreted as defined in the chapter Boolean Type in the AUTOSAR EcuC specification.</p> <p>In case the ComSignal is a UINT8_N, UINT8_DYN the string shall be interpreted as a decimal representation of the characters separated by blanks, e.g. "97 98 100" means a string "abd", where the char "a" is in byte 0 (lowest address), "b" is in byte 1, and "d" is in byte 2 and (highest address).</p> <p>For the ComSignalType UINT8_DYN the dynamic length shall be set to the number of configured characters. An empty string "" shall be interpreted as 0-sized dynamic signal.</p>		
Multiplicity	0..1		
Type	EcucStringParamDef		
Default value	0		
maxLength	--		
minLength	--		
regularExpression	--		
Post-Build Variant Multiplicity	true		
Post-Build Variant Value	true		
Multiplicity Configuration Class	Pre-compile time	X	VARIANT-PRE-COMPILE
	Link time	X	VARIANT-LINK-TIME
	Post-build time	X	VARIANT-POST-BUILD
Value Configuration Class	Pre-compile time	X	VARIANT-PRE-COMPILE
	Link time	X	VARIANT-LINK-TIME
	Post-build time	X	VARIANT-POST-BUILD
Scope / Dependency	scope: local dependency: In case of UINT8_N the length of ComSignalInitValue has to be the same as ComSignalLength.		

SWS Item	ECUC_Com_00437 :		
Name	ComSignalLength		
Parent Container	ComSignal		

Description	<p>Description:</p> <p>For ComSignalType UINT8_N this parameter specifies the length n in bytes. For ComSignalType UINT8_DYN it specifies the maximum length in bytes. For all other types this parameter shall be ignored.</p> <p>The supported maximum length is restricted by the used transportation system. For non TP-PDUs the maximum size of a PDU, and therefore also of any included signal, is limited by the concrete bus characteristic. For example, the limit is 8 bytes for CAN and LIN, 64 bytes for CAN FD and 254 for FlexRay.</p>		
Multiplicity	0..1		
Type	EcucIntegerParamDef		
Range	0 .. 4294967295		
Default value	--		
Post-Build Variant Multiplicity	false		
Post-Build Variant Value	false		
Multiplicity Configuration Class	Pre-compile time	X	VARIANT-PRE-COMPILE
	Link time	X	VARIANT-LINK-TIME, VARIANT-POST-BUILD
	Post-build time	--	
Value Configuration Class	Pre-compile time	X	VARIANT-PRE-COMPILE
	Link time	X	VARIANT-LINK-TIME, VARIANT-POST-BUILD
	Post-build time	--	
Scope / Dependency	scope: local		

SWS Item	ECUC_Com_00127 :		
Name	ComSignalType		
Parent Container	ComSignal		
Description	<p>The AUTOSAR type of the signal. Whether or not the signal is signed or unsigned can be found by examining the value of this attribute.</p> <p>This type could also be used to reserved appropriate storage in AUTOSAR COM.</p>		
Multiplicity	1		
Type	EcucEnumerationParamDef		
Range	BOOLEAN	--	
	FLOAT32	--	
	FLOAT64	--	
	SINT16	--	
	SINT32	--	
	SINT64	--	
	SINT8	--	
	UINT16	--	
	UINT32	--	
	UINT64	--	
	UINT8	--	
	UINT8_DYN	--	
	UINT8_N	--	
Post-Build Variant Value	false		
Value Configuration Class	Pre-compile time	X	VARIANT-PRE-COMPILE
	Link time	X	VARIANT-LINK-TIME, VARIANT-POST-BUILD
	Post-build time	--	
Scope / Dependency	scope: local		

SWS Item	ECUC_Com_00263 :		
Name	ComTimeout		
Parent Container	ComSignal		
Description	Defines the length of the deadline monitoring timeout period in seconds. The period for the first timeout period can be configured separately by ECUC_Com_00183.		
Multiplicity	0..1		
Type	EcucFloatParamDef		
Range	[0 .. 3600]		
Default value	--		
Post-Build Variant Multiplicity	true		
Post-Build Variant Value	true		
Multiplicity Configuration Class	Pre-compile time	X	VARIANT-PRE-COMPILE
	Link time	X	VARIANT-LINK-TIME
	Post-build time	X	VARIANT-POST-BUILD
Value Configuration Class	Pre-compile time	X	VARIANT-PRE-COMPILE
	Link time	X	VARIANT-LINK-TIME
	Post-build time	X	VARIANT-POST-BUILD
Scope / Dependency	scope: local		

SWS Item	ECUC_Com_00552 :		
Name	ComTimeoutNotification		
Parent Container	ComSignal		
Description	On sender side: Name of Com_CbkTxTOut callback function to be called. On receiver side: Name of Com_CbkRxTOut callback function to be called.		
Multiplicity	0..1		
Type	EcucFunctionNameDef		
Default value	--		
maxLength	--		
minLength	--		
regularExpression	--		
Post-Build Variant Multiplicity	false		
Post-Build Variant Value	false		
Multiplicity Configuration Class	Pre-compile time	X	VARIANT-PRE-COMPILE
	Link time	X	VARIANT-LINK-TIME, VARIANT-POST-BUILD
	Post-build time	--	
Value Configuration Class	Pre-compile time	X	VARIANT-PRE-COMPILE
	Link time	X	VARIANT-LINK-TIME, VARIANT-POST-BUILD
	Post-build time	--	
Scope / Dependency	scope: local		

SWS Item	ECUC_Com_10006 :		
Name	ComTimeoutSubstitutionValue		
Parent Container	ComSignal		
Description	<p>The signal substitution value will be used in case of a timeout and ComRxDataTimeoutAction is set to SUBSTITUTE.</p> <p>In case of UINT8_N the default value is a string of length ComSignalLength with all bytes set to 0x00.</p> <p>In case of UINT8_DYN the initial size shall be 0.</p> <p>In case the ComSignalType is UINT8, UINT16, UINT32, UINT64, SINT8, SINT16, SINT32, SINT64 the string shall be interpreted as defined in the</p>		

	chapter Integer Type in the AUTOSAR EcuC specification.		
	In case the ComSignalType is FLOAT32, FLOAT64 the string shall be interpreted as defined in the chapter Float Type in the AUTOSAR EcuC specification.		
	In case the ComSignalType is BOOLEAN the string shall be interpreted as defined in the chapter Boolean Type in the AUTOSAR EcuC specification.		
	In case the ComSignal is a UINT8_N, UINT8_DYN the string shall be interpreted as a decimal representation of the characters separated by blanks, e.g. "97 98 100" means a string "abd", where the char "a" is in byte 0 (lowest address), "b" is in byte 1, and "d" is in byte 2 and (highest address). For the ComSignalType UINT8_DYN the dynamic length shall be set to the number of configured characters. An empty string "" shall be interpreted as 0-sized dynamic signal.		
Multiplicity	0..1		
Type	EcucStringParamDef		
Default value	--		
maxLength	--		
minLength	--		
regularExpression	--		
Post-Build Variant Multiplicity	true		
Post-Build Variant Value	true		
Multiplicity Configuration Class	Pre-compile time	X	VARIANT-PRE-COMPILE
	Link time	X	VARIANT-LINK-TIME
	Post-build time	X	VARIANT-POST-BUILD
Value Configuration Class	Pre-compile time	X	VARIANT-PRE-COMPILE
	Link time	X	VARIANT-LINK-TIME
	Post-build time	X	VARIANT-POST-BUILD
Scope / Dependency	scope: local		

SWS Item	ECUC Com 00232 :	
Name	ComTransferProperty	
Parent Container	ComSignal	
Description	Defines if a write access to this signal can trigger the transmission of the corresponding I-PDU. If the I-PDU is triggered, depends also on the transmission mode of the corresponding I-PDU.	
Multiplicity	0..1	
Type	EcucEnumerationParamDef	
Range	PENDING	A write access to this signal never triggers the transmission of the corresponding I-PDU.
	TRIGGERED	Depending on the transmission mode, a write access to this signal can trigger the transmission of the corresponding I-PDU.
	TRIGGERED_ON_CHANGE	Depending on the transmission mode, a write access to this signal can trigger the transmission of the corresponding I-PDU, but only in case the written value is different to the

		locally stored (last sent or initial value) in length or value.
	TRIGGERED_ON_CHANGE_WITHOUT_REPETITION	Depending on the transmission mode, a write access to this signal can trigger the transmission of the corresponding I-PDU just once without a repetition, but only in case the written value is different to the locally stored (last sent or initial value) in length or value.
	TRIGGERED_WITHOUT_REPETITION	Depending on the transmission mode, a write access to this signal can trigger the transmission of the corresponding I-PDU just once without a repetition.
Post-Build Variant Multiplicity	true	
Post-Build Variant Value	true	
Multiplicity Configuration Class	Pre-compile time	X VARIANT-PRE-COMPILE
	Link time	X VARIANT-LINK-TIME
	Post-build time	X VARIANT-POST-BUILD
Value Configuration Class	Pre-compile time	X VARIANT-PRE-COMPILE
	Link time	X VARIANT-LINK-TIME
	Post-build time	X VARIANT-POST-BUILD
Scope / Dependency	scope: local	

SWS Item	ECUC Com_00257 :		
Name	ComUpdateBitPosition		
Parent Container	ComSignal		
Description	Bit position of update-bit inside I-PDU. If this attribute is omitted then there is no update-bit. This setting must be consistently on sender and on receiver side. Range: 0..63 for CAN and LIN, 0..511 for CAN FD, 0..2031 for FlexRay, 0..4294967295 for TP.		
Multiplicity	0..1		
Type	EcucIntegerParamDef		
Range	0 .. 4294967295		
Default value	--		
Post-Build Variant Multiplicity	true		
Post-Build Variant Value	true		
Multiplicity Configuration Class	Pre-compile time	X	VARIANT-PRE-COMPILE
	Link time	X	VARIANT-LINK-TIME
	Post-build time	X	VARIANT-POST-BUILD
Value Configuration Class	Pre-compile time	X	VARIANT-PRE-COMPILE

	Link time	X	VARIANT-LINK-TIME
	Post-build time	X	VARIANT-POST-BUILD
Scope / Dependency	scope: local		

SWS Item	ECUC_Com_00002 :		
Name	ComSystemTemplateSystemSignalRef		
Parent Container	ComSignal		
Description	Reference to the ISignalToIPduMapping that contains a reference to the ISignal (System Template) which this ComSignal (or ComGroupSignal) represents.		
Multiplicity	0..1		
Type	Foreign reference to [I-SIGNAL-TO-I-PDU-MAPPING]		
Post-Build Variant Multiplicity	true		
Post-Build Variant Value	true		
Multiplicity Configuration Class	Pre-compile time	X	VARIANT-PRE-COMPILE
	Link time	X	VARIANT-LINK-TIME
	Post-build time	X	VARIANT-POST-BUILD
Value Configuration Class	Pre-compile time	X	VARIANT-PRE-COMPILE
	Link time	X	VARIANT-LINK-TIME
	Post-build time	X	VARIANT-POST-BUILD
Scope / Dependency	scope: ECU		

Included Containers		
Container Name	Multiplicity	Scope / Dependency
ComFilter	0..1	This container contains the configuration parameters of the AUTOSAR COM module's Filters. Note: On sender side the container is used to specify the transmission mode conditions.

10.1.13 ComSignalGroup

SWS Item	ECUC_Com_00345 :		
Container Name	ComSignalGroup		
Description	Contains the configuration parameters of the AUTOSAR COM module's signal groups.		
Post-Build Variant Multiplicity	true		
Multiplicity Configuration Class	Pre-compile time	X	VARIANT-PRE-COMPILE
	Link time	X	VARIANT-LINK-TIME
	Post-build time	X	VARIANT-POST-BUILD
Configuration Parameters			

SWS Item	ECUC_Com_00314 :		
Name	ComDataInvalidAction		
Parent Container	ComSignalGroup		
Description	This parameter defines the action performed upon reception of an invalid signal. Relating to signal groups the action in case if one of the included signals is an invalid signal. If Replace is used the ComSignalInitValue will be used for the replacement.		
Multiplicity	0..1		
Type	EcucEnumerationParamDef		
Range	NOTIFY		--

	REPLACE	Literal for DataInvalidAction
Post-Build Variant Multiplicity	false	
Post-Build Variant Value	false	
Multiplicity Configuration Class	Pre-compile time	X VARIANT-PRE-COMPILE
	Link time	X VARIANT-LINK-TIME, VARIANT-POST-BUILD
	Post-build time	--
Value Configuration Class	Pre-compile time	X VARIANT-PRE-COMPILE
	Link time	X VARIANT-LINK-TIME, VARIANT-POST-BUILD
	Post-build time	--
Scope / Dependency	scope: local	

SWS Item	ECUC_Com_00499 :	
Name	ComErrorNotification	
Parent Container	ComSignalGroup	
Description	Only valid on sender side: Name of Com_CbkTxErr callback function to be called. If this parameter is omitted no error notification shall take place.	
Multiplicity	0..1	
Type	EcucFunctionNameDef	
Default value	--	
maxLength	--	
minLength	--	
regularExpression	--	
Post-Build Variant Multiplicity	false	
Post-Build Variant Value	false	
Multiplicity Configuration Class	Pre-compile time	X VARIANT-PRE-COMPILE
	Link time	X VARIANT-LINK-TIME, VARIANT-POST-BUILD
	Post-build time	--
Value Configuration Class	Pre-compile time	X VARIANT-PRE-COMPILE
	Link time	X VARIANT-LINK-TIME, VARIANT-POST-BUILD
	Post-build time	--
Scope / Dependency	scope: local	

SWS Item	ECUC_Com_00183 :	
Name	ComFirstTimeout	
Parent Container	ComSignalGroup	
Description	Defines the length of the first deadline monitoring timeout period in seconds. This timeout is used immediately after start (or restart) of the deadline monitoring service. The timeout period of the successive periods is configured by ECUC_Com_00263.	
Multiplicity	0..1	
Type	EcucFloatParamDef	
Range	[0 .. 3600]	
Default value	--	
Post-Build Variant Multiplicity	true	
Post-Build Variant Value	true	
Multiplicity Configuration Class	Pre-compile time	X VARIANT-PRE-COMPILE

Class	Link time	X	VARIANT-LINK-TIME
	Post-build time	X	VARIANT-POST-BUILD
Value Configuration Class	Pre-compile time	X	VARIANT-PRE-COMPILE
	Link time	X	VARIANT-LINK-TIME
	Post-build time	X	VARIANT-POST-BUILD
Scope / Dependency	scope: local		

SWS Item	ECUC_Com_00165 :		
Name	ComHandleId		
Parent Container	ComSignalGroup		
Description	The numerical value used as the ID. This ID identifies signals and signal groups in the COM APIs using Com_SignalIdType or Com_SignalGroupIdType parameter respectively.		
Multiplicity	0..1		
Type	EcucIntegerParamDef (Symbolic Name generated for this parameter)		
Range	0 .. 65535		
Default value	--		
Post-Build Variant Multiplicity	false		
Post-Build Variant Value	false		
Multiplicity Configuration Class	Pre-compile time	X	All Variants
	Link time	--	
	Post-build time	--	
Value Configuration Class	Pre-compile time	X	All Variants
	Link time	--	
	Post-build time	--	
Scope / Dependency	scope: ECU		

SWS Item	ECUC_Com_00811 :		
Name	ComInitialValueOnly		
Parent Container	ComSignalGroup		
Description	This parameter defines that the respective signal's initial value shall be put into the respective PDU but there will not be any update of the value through the RTE. Thus the Com implementation does not need to expect any API calls for this signal (group).		
Multiplicity	0..1		
Type	EcucBooleanParamDef		
Default value	false		
Post-Build Variant Multiplicity	false		
Post-Build Variant Value	false		
Multiplicity Configuration Class	Pre-compile time	X	VARIANT-PRE-COMPILE
	Link time	X	VARIANT-LINK-TIME, VARIANT-POST-BUILD
	Post-build time	--	
Value Configuration Class	Pre-compile time	X	VARIANT-PRE-COMPILE
	Link time	X	VARIANT-LINK-TIME, VARIANT-POST-BUILD
	Post-build time	--	
Scope / Dependency	scope: local		

SWS Item	ECUC_Com_00315 :		
Name	ComInvalidNotification		
Parent Container	ComSignalGroup		
Description	Only valid on receiver side: Name of Com_CbkInv callback function to be called. Name of the function which notifies the RTE about the reception of		

	an invalidated signal/ signal group. Only applicable if ComDataInvalidAction is configured to NOTIFY.		
Multiplicity	0..1		
Type	EcucFunctionNameDef		
Default value	--		
maxLength	--		
minLength	--		
regularExpression	--		
Post-Build Variant Multiplicity	false		
Post-Build Variant Value	false		
Multiplicity Configuration Class	Pre-compile time	X	VARIANT-PRE-COMPILE
	Link time	X	VARIANT-LINK-TIME, VARIANT-POST-BUILD
	Post-build time	--	
Value Configuration Class	Pre-compile time	X	VARIANT-PRE-COMPILE
	Link time	X	VARIANT-LINK-TIME, VARIANT-POST-BUILD
	Post-build time	--	
Scope / Dependency	scope: local		

SWS Item	ECUC_Com_00498 :		
Name	ComNotification		
Parent Container	ComSignalGroup		
Description	On sender side: Name of Com_CbkTxAck callback function to be called. On receiver side: Name of Com_CbkRxAck callback function to be called. If this parameter is omitted no notification shall take place.		
Multiplicity	0..1		
Type	EcucFunctionNameDef		
Default value	--		
maxLength	--		
minLength	--		
regularExpression	--		
Post-Build Variant Multiplicity	false		
Post-Build Variant Value	false		
Multiplicity Configuration Class	Pre-compile time	X	VARIANT-PRE-COMPILE
	Link time	X	VARIANT-LINK-TIME, VARIANT-POST-BUILD
	Post-build time	--	
Value Configuration Class	Pre-compile time	X	VARIANT-PRE-COMPILE
	Link time	X	VARIANT-LINK-TIME, VARIANT-POST-BUILD
	Post-build time	--	
Scope / Dependency	scope: local		

SWS Item	ECUC_Com_00412 :	
Name	ComRxDataTimeoutAction	
Parent Container	ComSignalGroup	
Description	This parameter defines the action performed upon expiration of the reception deadline monitoring timer.	
Multiplicity	0..1	
Type	EcucEnumerationParamDef	
Range	NONE	no replacement shall take place
	REPLACE	signals shall be replaced by their

		ComSignalInitValue
	SUBSTITUTE	signals shall be replaced by their ComTimeoutSubstitutionValue
Post-Build Variant Multiplicity	false	
Post-Build Variant Value	false	
Multiplicity Configuration Class	Pre-compile time	X VARIANT-PRE-COMPILE
	Link time	X VARIANT-LINK-TIME, VARIANT-POST-BUILD
	Post-build time	--
Value Configuration Class	Pre-compile time	X VARIANT-PRE-COMPILE
	Link time	X VARIANT-LINK-TIME, VARIANT-POST-BUILD
	Post-build time	--
Scope / Dependency	scope: local	

SWS Item	ECUC_Com_10003 :		
Name	ComSignalGroupArrayAccess		
Parent Container	ComSignalGroup		
Description	Defines whether the uint8-array based access shall be used for this ComSignalGroup.		
Multiplicity	0..1		
Type	EcucBooleanParamDef		
Default value	--		
Post-Build Variant Multiplicity	false		
Post-Build Variant Value	false		
Multiplicity Configuration Class	Pre-compile time	X	All Variants
	Link time	--	
	Post-build time	--	
Value Configuration Class	Pre-compile time	X	All Variants
	Link time	--	
	Post-build time	--	
Scope / Dependency			

SWS Item	ECUC_Com_00263 :		
Name	ComTimeout		
Parent Container	ComSignalGroup		
Description	Defines the length of the deadline monitoring timeout period in seconds. The period for the first timeout period can be configured separately by ECUC_Com_00183.		
Multiplicity	0..1		
Type	EcucFloatParamDef		
Range	[0 .. 3600]		
Default value	--		
Post-Build Variant Multiplicity	true		
Post-Build Variant Value	true		
Multiplicity Configuration Class	Pre-compile time	X	VARIANT-PRE-COMPILE
	Link time	X	VARIANT-LINK-TIME
	Post-build time	X	VARIANT-POST-BUILD
Value Configuration Class	Pre-compile time	X	VARIANT-PRE-COMPILE
	Link time	X	VARIANT-LINK-TIME
	Post-build time	X	VARIANT-POST-BUILD

Scope / Dependency	scope: local		
SWS Item	ECUC_Com_00552 :		
Name	ComTimeoutNotification		
Parent Container	ComSignalGroup		
Description	On sender side: Name of Com_CbkTxTOut callback function to be called. On receiver side: Name of Com_CbkRxTOut callback function to be called.		
Multiplicity	0..1		
Type	EcucFunctionNameDef		
Default value	--		
maxLength	--		
minLength	--		
regularExpression	--		
Post-Build Variant Multiplicity	false		
Post-Build Variant Value	false		
Multiplicity Configuration Class	Pre-compile time	X	VARIANT-PRE-COMPILE
	Link time	X	VARIANT-LINK-TIME, VARIANT-POST-BUILD
	Post-build time	--	
Value Configuration Class	Pre-compile time	X	VARIANT-PRE-COMPILE
	Link time	X	VARIANT-LINK-TIME, VARIANT-POST-BUILD
	Post-build time	--	
Scope / Dependency	scope: local		

SWS Item	ECUC_Com_00232 :	
Name	ComTransferProperty	
Parent Container	ComSignalGroup	
Description	Defines if a write access to this signal can trigger the transmission of the corresponding I-PDU. If the I-PDU is triggered, depends also on the transmission mode of the corresponding I-PDU.	
Multiplicity	0..1	
Type	EcucEnumerationParamDef	
Range	PENDING	A write access to this signal never triggers the transmission of the corresponding I-PDU.
	TRIGGERED	Depending on the transmission mode, a write access to this signal can trigger the transmission of the corresponding I-PDU.
	TRIGGERED_ON_CHANGE	Depending on the transmission mode, a write access to this signal can trigger the transmission of the corresponding I-PDU, but only in case the written value is different to the locally stored (last sent or initial value) in length or value.
	TRIGGERED_ON_CHANGE_WITHOUT_REPETITION	Depending on the transmission mode, a write access to this signal can

		trigger the transmission of the corresponding I-PDU just once without a repetition, but only in case the written value is different to the locally stored (last sent or initial value) in length or value.
	TRIGGERED_WITHOUT_REPETITION	Depending on the transmission mode, a write access to this signal can trigger the transmission of the corresponding I-PDU just once without a repetition.
Post-Build Variant Multiplicity	true	
Post-Build Variant Value	true	
Multiplicity Configuration Class	Pre-compile time	X VARIANT-PRE-COMPILE
	Link time	X VARIANT-LINK-TIME
	Post-build time	X VARIANT-POST-BUILD
Value Configuration Class	Pre-compile time	X VARIANT-PRE-COMPILE
	Link time	X VARIANT-LINK-TIME
	Post-build time	X VARIANT-POST-BUILD
Scope / Dependency	scope: local	

SWS Item	ECUC_Com_00257 :		
Name	ComUpdateBitPosition		
Parent Container	ComSignalGroup		
Description	<p>Bit position of update-bit inside I-PDU. If this attribute is omitted then there is no update-bit. This setting must be consistently on sender and on receiver side.</p> <p>Range: 0..63 for CAN and LIN, 0..511 for CAN FD, 0..2031 for FlexRay, 0..4294967295 for TP.</p>		
Multiplicity	0..1		
Type	EcucIntegerParamDef		
Range	0 .. 4294967295		
Default value	--		
Post-Build Variant Multiplicity	true		
Post-Build Variant Value	true		
Multiplicity Configuration Class	Pre-compile time	X	VARIANT-PRE-COMPILE
	Link time	X	VARIANT-LINK-TIME
	Post-build time	X	VARIANT-POST-BUILD
Value Configuration Class	Pre-compile time	X	VARIANT-PRE-COMPILE
	Link time	X	VARIANT-LINK-TIME
	Post-build time	X	VARIANT-POST-BUILD
Scope / Dependency	scope: local		

SWS Item	ECUC_Com_00001 :		
-----------------	-------------------------	--	--

Name	ComSystemTemplateSignalGroupRef		
Parent Container	ComSignalGroup		
Description	Reference to the ISignalToIPduMapping that contains a reference to the ISignalGroup (SystemTemplate) which this ComSignalGroup represents.		
Multiplicity	0..1		
Type	Foreign reference to [I-SIGNAL-TO-I-PDU-MAPPING]		
Post-Build Variant Multiplicity	true		
Post-Build Variant Value	true		
Multiplicity Configuration Class	Pre-compile time	X	VARIANT-PRE-COMPILE
	Link time	X	VARIANT-LINK-TIME
	Post-build time	X	VARIANT-POST-BUILD
Value Configuration Class	Pre-compile time	X	VARIANT-PRE-COMPILE
	Link time	X	VARIANT-LINK-TIME
	Post-build time	X	VARIANT-POST-BUILD
Scope / Dependency	scope: ECU		

Included Containers		
Container Name	Multiplicity	Scope / Dependency
ComGroupSignal	0..*	This container contains the configuration parameters of group signals. I.e. signals that are included within a signal group.

10.1.14 ComGroupSignal

SWS Item	ECUC_Com_00520 :		
Container Name	ComGroupSignal		
Description	This container contains the configuration parameters of group signals. I.e. signals that are included within a signal group.		
Post-Build Variant Multiplicity	true		
Multiplicity Configuration Class	Pre-compile time	X	VARIANT-PRE-COMPILE
	Link time	X	VARIANT-LINK-TIME
	Post-build time	X	VARIANT-POST-BUILD
Configuration Parameters			

SWS Item	ECUC_Com_00259 :		
Name	ComBitPosition		
Parent Container	ComGroupSignal		
Description	Starting position within the I-PDU. This parameter refers to the position in the I-PDU and not in the shadow buffer. If the endianness conversion is configured to Opaque the parameter ComBitPosition shall define the bit0 of the first byte like in little endian byte order		
Multiplicity	1		
Type	EcucIntegerParamDef		
Range	0 .. 4294967295		
Default value	--		
Post-Build Variant Value	true		
Value Configuration Class	Pre-compile time	X	VARIANT-PRE-COMPILE
	Link time	X	VARIANT-LINK-TIME
	Post-build time	X	VARIANT-POST-BUILD
Scope / Dependency	scope: local		

SWS Item	ECUC_Com_00158 :		
-----------------	------------------	--	--

Name	ComBitSize		
Parent Container	ComGroupSignal		
Description	Size in bits, for integer signal types. For ComSignalType UINT8_N and UINT8_DYN the size shall be configured by ComSignalLength. For ComSignalTypes FLOAT32 and FLOAT64 the size is already defined by the signal type and therefore may be omitted.		
Multiplicity	0..1		
Type	EcucIntegerParamDef		
Range	0 .. 64		
Default value	--		
Post-Build Variant Multiplicity	true		
Post-Build Variant Value	true		
Multiplicity Configuration Class	Pre-compile time	X	VARIANT-PRE-COMPILE
	Link time	X	VARIANT-LINK-TIME
	Post-build time	X	VARIANT-POST-BUILD
Value Configuration Class	Pre-compile time	X	VARIANT-PRE-COMPILE
	Link time	X	VARIANT-LINK-TIME
	Post-build time	X	VARIANT-POST-BUILD
Scope / Dependency	scope: local		

SWS Item	ECUC_Com_00165 :		
Name	ComHandleId		
Parent Container	ComGroupSignal		
Description	The numerical value used as the ID. This ID identifies signals and signal groups in the COM APIs using Com_SignalIdType or Com_SignalGroupIdType parameter respectively.		
Multiplicity	0..1		
Type	EcucIntegerParamDef (Symbolic Name generated for this parameter)		
Range	0 .. 65535		
Default value	--		
Post-Build Variant Multiplicity	false		
Post-Build Variant Value	false		
Multiplicity Configuration Class	Pre-compile time	X	All Variants
	Link time	--	
	Post-build time	--	
Value Configuration Class	Pre-compile time	X	All Variants
	Link time	--	
	Post-build time	--	
Scope / Dependency	scope: ECU		

SWS Item	ECUC_Com_00391 :		
Name	ComSignalDataInvalidValue		
Parent Container	ComGroupSignal		
Description	Defines the data invalid value of the signal. In case the ComSignalType is UINT8, UINT16, UINT32, UINT64, SINT8, SINT16, SINT32, SINT64 the string shall be interpreted as defined in the chapter Integer Type in the AUTOSAR EcuC specification. In case the ComSignalType is FLOAT32, FLOAT64 the string shall be interpreted as defined in the chapter Float Type in the AUTOSAR EcuC specification. In case the ComSignalType is BOOLEAN the string shall be interpreted as defined in the chapter Boolean Type in the AUTOSAR EcuC specification. In case the ComSignal is a UINT8_N, UINT8_DYN the string shall be		

	<p>interpreted as a decimal representation of the characters separated by blanks, e.g. "97 98 100" means a string "abd", where the char "a" is in byte 0 (lowest address), "b" is in byte 1, and "d" is in byte 2 and (highest address).</p> <p>For the ComSignalType UINT8_DYN the dynamic length shall be set to the number of configured characters. An empty string "" shall be interpreted as 0-sized dynamic signal.</p>		
Multiplicity	0..1		
Type	EcucStringParamDef		
Default value	--		
maxLength	--		
minLength	--		
regularExpression	--		
Post-Build Variant Multiplicity	false		
Post-Build Variant Value	false		
Multiplicity Configuration Class	Pre-compile time	X	VARIANT-PRE-COMPILE
	Link time	X	VARIANT-LINK-TIME, VARIANT-POST-BUILD
	Post-build time	--	
Value Configuration Class	Pre-compile time	X	VARIANT-PRE-COMPILE
	Link time	X	VARIANT-LINK-TIME, VARIANT-POST-BUILD
	Post-build time	--	
Scope / Dependency	<p>scope: local</p> <p>dependency: In case of UINT8_N the length of ComSignalDataInvalidValue has to be the same as ComSignalLength.</p>		

SWS Item	ECUC_Com_00157 :		
Name	ComSignalEndianness		
Parent Container	ComGroupSignal		
Description	Defines the endianness of the signal's network representation.		
Multiplicity	1		
Type	EcucEnumerationParamDef		
Range	BIG_ENDIAN	--	
	LITTLE_ENDIAN	--	
	OPAQUE	--	
Post-Build Variant Value	true		
Value Configuration Class	Pre-compile time	X	VARIANT-PRE-COMPILE
	Link time	X	VARIANT-LINK-TIME
	Post-build time	X	VARIANT-POST-BUILD
Scope / Dependency	scope: local		

SWS Item	ECUC_Com_00170 :		
Name	ComSignalInitValue		
Parent Container	ComGroupSignal		
Description	<p>Initial value for this signal. In case of UINT8_N the default value is a string of length ComSignalLength with all bytes set to 0x00. In case of UINT8_DYN the initial size shall be 0.</p> <p>In case the ComSignalType is UINT8, UINT16, UINT32, UINT64, SINT8, SINT16, SINT32, SINT64 the string shall be interpreted as defined in the chapter Integer Type in the AUTOSAR EcuC specification.</p> <p>In case the ComSignalType is FLOAT32, FLOAT64 the string shall be interpreted as defined in the chapter Float Type in the AUTOSAR EcuC specification.</p>		

	<p>In case the ComSignalType is BOOLEAN the string shall be interpreted as defined in the chapter Boolean Type in the AUTOSAR EcuC specification. In case the ComSignal is a UINT8_N, UINT8_DYN the string shall be interpreted as a decimal representation of the characters separated by blanks, e.g. "97 98 100" means a string "abd", where the char "a" is in byte 0 (lowest address), "b" is in byte 1, and "d" is in byte 2 and (highest address).</p> <p>For the ComSignalType UINT8_DYN the dynamic length shall be set to the number of configured characters. An empty string "" shall be interpreted as 0-sized dynamic signal.</p>		
Multiplicity	0..1		
Type	EcucStringParamDef		
Default value	0		
maxLength	--		
minLength	--		
regularExpression	--		
Post-Build Variant Multiplicity	true		
Post-Build Variant Value	true		
Multiplicity Configuration Class	Pre-compile time	X	VARIANT-PRE-COMPILE
	Link time	X	VARIANT-LINK-TIME
	Post-build time	X	VARIANT-POST-BUILD
Value Configuration Class	Pre-compile time	X	VARIANT-PRE-COMPILE
	Link time	X	VARIANT-LINK-TIME
	Post-build time	X	VARIANT-POST-BUILD
Scope / Dependency	<p>scope: local</p> <p>dependency: In case of UINT8_N the length of ComSignalNnitValue has to be the same as ComSignalLength.</p>		

SWS Item	ECUC_Com_00437 :		
Name	ComSignalLength		
Parent Container	ComGroupSignal		
Description	<p>Description:</p> <p>For ComSignalType UINT8_N this parameter specifies the length n in bytes. For ComSignalType UINT8_DYN it specifies the maximum length in bytes. For all other types this parameter shall be ignored.</p> <p>The supported maximum length is restricted by the used transportation system. For non TP-PDUs the maximum size of a PDU, and therefore also of any included signal, is limited by the concrete bus characteristic. For example, the limit is 8 bytes for CAN and LIN, 64 bytes for CAN FD and 254 for FlexRay.</p>		
Multiplicity	0..1		
Type	EcucIntegerParamDef		
Range	0 .. 4294967295		
Default value	--		
Post-Build Variant Multiplicity	false		
Post-Build Variant Value	false		
Multiplicity Configuration Class	Pre-compile time	X	VARIANT-PRE-COMPILE
	Link time	X	VARIANT-LINK-TIME, VARIANT-POST-BUILD
	Post-build time	--	
Value Configuration Class	Pre-compile time	X	VARIANT-PRE-COMPILE
	Link time	X	VARIANT-LINK-TIME, VARIANT-POST-BUILD
	Post-build time	--	

Scope / Dependency	scope: local	
SWS Item	ECUC_Com_00127 :	
Name	ComSignalType	
Parent Container	ComGroupSignal	
Description	The AUTOSAR type of the signal. Whether or not the signal is signed or unsigned can be found by examining the value of this attribute. This type could also be used to reserved appropriate storage in AUTOSAR COM.	
Multiplicity	1	
Type	EcucEnumerationParamDef	
Range	BOOLEAN	--
	FLOAT32	--
	FLOAT64	--
	SINT16	--
	SINT32	--
	SINT64	--
	SINT8	--
	UINT16	--
	UINT32	--
	UINT64	--
	UINT8	--
	UINT8_DYN	--
	UINT8_N	--
Post-Build Variant Value	false	
Value Configuration Class	Pre-compile time	X VARIANT-PRE-COMPILE
	Link time	X VARIANT-LINK-TIME, VARIANT-POST-BUILD
	Post-build time	--
Scope / Dependency	scope: local	

SWS Item	ECUC_Com_10006 :	
Name	ComTimeoutSubstitutionValue	
Parent Container	ComGroupSignal	
Description	<p>The signal substitution value will be used in case of a timeout and ComRxDataTimeoutAction is set to SUBSTITUTE. In case of UINT8_N the default value is a string of length ComSignalLength with all bytes set to 0x00.</p> <p>In case of UINT8_DYN the initial size shall be 0.</p> <p>In case the ComSignalType is UINT8, UINT16, UINT32, UINT64, SINT8, SINT16, SINT32, SINT64 the string shall be interpreted as defined in the chapter Integer Type in the AUTOSAR EcuC specification.</p> <p>In case the ComSignalType is FLOAT32, FLOAT64 the string shall be interpreted as defined in the chapter Float Type in the AUTOSAR EcuC specification.</p> <p>In case the ComSignalType is BOOLEAN the string shall be interpreted as defined in the chapter Boolean Type in the AUTOSAR EcuC specification.</p> <p>In case the ComSignal is a UINT8_N, UINT8_DYN the string shall be interpreted as a decimal representation of the characters separated by blanks, e.g. "97 98 100" means a string "abd", where the char "a" is in byte 0(lowest address), "b" is in byte 1, and "d" is in byte 2 and (highest address). For the ComSignalType UINT8_DYN the dynamic length shall</p>	

	be set to the number of configured characters. An empty string "" shall be interpreted as 0-sized dynamic signal.		
Multiplicity	0..1		
Type	EcucStringParamDef		
Default value	--		
maxLength	--		
minLength	--		
regularExpression	--		
Post-Build Variant Multiplicity	true		
Post-Build Variant Value	true		
Multiplicity Configuration Class	Pre-compile time	X	VARIANT-PRE-COMPILE
	Link time	X	VARIANT-LINK-TIME
	Post-build time	X	VARIANT-POST-BUILD
Value Configuration Class	Pre-compile time	X	VARIANT-PRE-COMPILE
	Link time	X	VARIANT-LINK-TIME
	Post-build time	X	VARIANT-POST-BUILD
Scope / Dependency	scope: local		

SWS Item	ECUC_Com_00560 :		
Name	ComTransferProperty		
Parent Container	ComGroupSignal		
Description	Optionally defines whether this group signal shall contribute to the TRIGGERED_ON_CHANGE transfer property of the signal group. If at least one group signal of a signal group has the "ComTransferProperty" configured all other group signals of that signal group shall have the attribute configured as well.		
Multiplicity	0..1		
Type	EcucEnumerationParamDef		
Range	PENDING	A change of the value of this group signal shall not be considered in the evaluation of the signal groups ComTransferProperty.	
	TRIGGERED_ON_CHANGE	A change of the value of this group signal shall be considered in the evaluation of the signal groups ComTransferProperty.	
Post-Build Variant Multiplicity	true		
Post-Build Variant Value	true		
Multiplicity Configuration Class	Pre-compile time	X	VARIANT-PRE-COMPILE
	Link time	X	VARIANT-LINK-TIME
	Post-build time	X	VARIANT-POST-BUILD
Value Configuration Class	Pre-compile time	X	VARIANT-PRE-COMPILE
	Link time	X	VARIANT-LINK-TIME
	Post-build time	X	VARIANT-POST-BUILD
Scope / Dependency	scope: local		

SWS Item	ECUC_Com_00002 :		
Name	ComSystemTemplateSystemSignalRef		
Parent Container	ComGroupSignal		
Description	Reference to the ISignalToIPduMapping that contains a reference to the ISignal (System Template) which this ComSignal (or ComGroupSignal) represents.		
Multiplicity	0..1		
Type	Foreign reference to [I-SIGNAL-TO-I-PDU-MAPPING]		

Post-Build Variant Multiplicity	true		
Post-Build Variant Value	true		
Multiplicity Configuration Class	Pre-compile time	X	VARIANT-PRE-COMPILE
	Link time	X	VARIANT-LINK-TIME
	Post-build time	X	VARIANT-POST-BUILD
Value Configuration Class	Pre-compile time	X	VARIANT-PRE-COMPILE
	Link time	X	VARIANT-LINK-TIME
	Post-build time	X	VARIANT-POST-BUILD
Scope / Dependency	scope: ECU		

Included Containers		
Container Name	Multiplicity	Scope / Dependency
ComFilter	0..1	This container contains the configuration parameters of the AUTOSAR COM module's filters. Note: On sender side the container is used to specify the transmission mode conditions.

10.1.15 ComTxMode

SWS Item	ECUC_Com_00351 :
Container Name	ComTxMode
Description	This container contains the configuration parameters of the AUTOSAR COM module's transmission modes.
Configuration Parameters	

SWS Item	ECUC_Com_00137 :		
Name	ComTxModeMode		
Parent Container	ComTxMode		
Description	The available transmission modes described in [18] shall be extended by the additional mode None. The transmission mode None shall not have any further sub-attributes in the ComTxMode object.		
Multiplicity	1		
Type	EcucEnumerationParamDef		
Range	DIRECT	--	
	MIXED	--	
	NONE	Literal for TxMode	
	PERIODIC	--	
Post-Build Variant Value	true		
Value Configuration Class	Pre-compile time	X	VARIANT-PRE-COMPILE
	Link time	X	VARIANT-LINK-TIME
	Post-build time	X	VARIANT-POST-BUILD
Scope / Dependency	scope: local		

SWS Item	ECUC_Com_00281 :	
Name	ComTxModeNumberOfRepetitions	
Parent Container	ComTxMode	
Description	Defines the number of repetitions for the transmission mode DIRECT and the event driven part of transmission mode MIXED.	
Multiplicity	0..1	

Type	EcucIntegerParamDef		
Range	0 .. 255		
Default value	--		
Post-Build Variant Multiplicity	true		
Post-Build Variant Value	true		
Multiplicity Configuration Class	Pre-compile time	X	VARIANT-PRE-COMPILE
	Link time	X	VARIANT-LINK-TIME
	Post-build time	X	VARIANT-POST-BUILD
Value Configuration Class	Pre-compile time	X	VARIANT-PRE-COMPILE
	Link time	X	VARIANT-LINK-TIME
	Post-build time	X	VARIANT-POST-BUILD
Scope / Dependency	scope: local		

SWS Item	ECUC Com_00282 :		
Name	ComTxModeRepetitionPeriod		
Parent Container	ComTxMode		
Description	Defines the repetition period in seconds of the multiple transmissions in case ComTxModeNumberOfRepetitions is configured greater than or equal to 1 and ComTxModeMode is configured to DIRECT or MIXED. In case of the mixed transmission mode only the event driven part is affected.		
Multiplicity	0..1		
Type	EcucFloatParamDef		
Range	[0 .. 3600]		
Default value	--		
Post-Build Variant Multiplicity	true		
Post-Build Variant Value	true		
Multiplicity Configuration Class	Pre-compile time	X	VARIANT-PRE-COMPILE
	Link time	X	VARIANT-LINK-TIME
	Post-build time	X	VARIANT-POST-BUILD
Value Configuration Class	Pre-compile time	X	VARIANT-PRE-COMPILE
	Link time	X	VARIANT-LINK-TIME
	Post-build time	X	VARIANT-POST-BUILD
Scope / Dependency	scope: local		

SWS Item	ECUC Com_00180 :		
Name	ComTxModeTimeOffset		
Parent Container	ComTxMode		
Description	Defines the period in seconds between the start of the I-PDU by Com_IpduGroupStart and the first transmission request in case ComTxModeMode is configured to PERIODIC or MIXED. In case of the mixed transmission mode only the periodic part is affected. In case ComTxModeTimeOffset is omitted or configured to 0, the first periodic transmission shall be transmitted within the next invocation of Com_MainFunctionTx.		
Multiplicity	0..1		
Type	EcucFloatParamDef		
Range	[0 .. 3600]		
Default value	--		
Post-Build Variant Multiplicity	true		
Post-Build Variant Value	true		
Multiplicity Configuration Class	Pre-compile time	X	VARIANT-PRE-COMPILE
	Link time	X	VARIANT-LINK-TIME
	Post-build time	X	VARIANT-POST-BUILD

Value Configuration Class	Pre-compile time	X	VARIANT-PRE-COMPILE
	Link time	X	VARIANT-LINK-TIME
	Post-build time	X	VARIANT-POST-BUILD
Scope / Dependency	scope: local		

SWS Item			
ECUC_Com_00178 :			
Name	ComTxModeTimePeriod		
Parent Container	ComTxMode		
Description	Defines the repetition period in seconds of the periodic transmission requests in case ComTxModeMode is configured to PERIODIC or MIXED. In case of the mixed transmission mode only the periodic part is affected.		
Multiplicity	0..1		
Type	EcucFloatParamDef		
Range	[0 .. 3600]		
Default value	--		
Post-Build Variant Multiplicity	true		
Post-Build Variant Value	true		
Multiplicity Configuration Class	Pre-compile time	X	VARIANT-PRE-COMPILE
	Link time	X	VARIANT-LINK-TIME
	Post-build time	X	VARIANT-POST-BUILD
Value Configuration Class	Pre-compile time	X	VARIANT-PRE-COMPILE
	Link time	X	VARIANT-LINK-TIME
	Post-build time	X	VARIANT-POST-BUILD
Scope / Dependency	scope: local		

No Included Containers

10.1.16 ComTxModeTrue

SWS Item	ECUC_Com_00455 :		
Container Name	ComTxModeTrue		
Description	This container contains the configuration parameters of the AUTOSAR COM module's transmission modes in the case the ComFilter evaluates to true.		
Configuration Parameters			

Included Containers			
Container Name	Multiplicity	Scope / Dependency	
ComTxMode	1	This container contains the configuration parameters of the AUTOSAR COM module's transmission modes.	

10.1.17 ComTxModeFalse

SWS Item	ECUC_Com_00454 :		
Container Name	ComTxModeFalse		
Description	This container contains the configuration parameters of the AUTOSAR COM module's transmission modes in the case the ComFilter evaluates to false.		
Configuration Parameters			

Included Containers		
Container Name	Multiplicity	Scope / Dependency
ComTxMode	1	This container contains the configuration parameters of the AUTOSAR COM module's transmission modes.

10.1.18 ComGwMapping

SWS Item	ECUC_Com_00544 :		
Container Name	ComGwMapping		
Description	Each instance of this container defines one mapping of the integrated Signal Gateway.		
Post-Build Variant Multiplicity	true		
Multiplicity Configuration Class	Pre-compile time	X	VARIANT-PRE-COMPILE
	Link time	X	VARIANT-LINK-TIME
	Post-build time	X	VARIANT-POST-BUILD
Configuration Parameters			

Included Containers		
Container Name	Multiplicity	Scope / Dependency
ComGwDestination	1..*	Each instance of this choice container allows to define one routing destination either by reference to an already configured COM signal / group signal or by a destination description container.
ComGwSource	1	This choice container allows the definition of the gateway source signal either by reference to an already configured COM signal / group signal or by a source description container.

10.1.19 ComGwSource

SWS Item	ECUC_Com_00545 :		
Choice container Name	ComGwSource		
Description	This choice container allows the definition of the gateway source signal either by reference to an already configured COM signal / group signal or by a source description container.		

Container Choices		
Container Name	Multiplicity	Scope / Dependency
ComGwSignal	0..1	This container allows specifying a gateway source or destination respectively with a reference to a ComSignal or a ComGroupSignal.
ComGwSourceDescription	0..1	Description of a gateway source. This container allows defining a gateway source without the configuration of a complete COM signal. This allows adding / changing gateway relations post build without the configuration of new signals.

10.1.20 ComGwSourceDescription

SWS Item	ECUC_Com_00548 :
Container Name	ComGwSourceDescription
Description	Description of a gateway source. This container allows defining a gateway source without the configuration of a complete COM signal. This allows adding / changing gateway relations post build without the configuration of new signals.
Configuration Parameters	

SWS Item	ECUC_Com_00259 :		
Name	ComBitPosition		
Parent Container	ComGwSourceDescription		
Description	Starting position within the I-PDU. This parameter refers to the position in the I-PDU and not in the shadow buffer. If the endianness conversion is configured to Opaque the parameter ComBitPosition shall define the bit0 of the first byte like in little endian byte order		
Multiplicity	1		
Type	EcuIntegerParamDef		
Range	0 .. 4294967295		
Default value	--		
Post-Build Variant Value	true		
Value Configuration Class	Pre-compile time	X	VARIANT-PRE-COMPILE
	Link time	X	VARIANT-LINK-TIME
	Post-build time	X	VARIANT-POST-BUILD
Scope / Dependency	scope: local		

SWS Item	ECUC_Com_00158 :		
Name	ComBitSize		
Parent Container	ComGwSourceDescription		
Description	Size in bits, for integer signal types. For ComSignalType UINT8_N and UINT8_DYN the size shall be configured by ComSignalLength. For ComSignalTypes FLOAT32 and FLOAT64 the size is already defined by the signal type and therefore may be omitted.		
Multiplicity	0..1		
Type	EcuIntegerParamDef		
Range	0 .. 64		
Default value	--		
Post-Build Variant Multiplicity	true		
Post-Build Variant Value	true		
Multiplicity Configuration Class	Pre-compile time	X	VARIANT-PRE-COMPILE
	Link time	X	VARIANT-LINK-TIME
	Post-build time	X	VARIANT-POST-BUILD
Value Configuration Class	Pre-compile time	X	VARIANT-PRE-COMPILE
	Link time	X	VARIANT-LINK-TIME
	Post-build time	X	VARIANT-POST-BUILD
Scope / Dependency	scope: local		

SWS Item	ECUC_Com_00157 :		
Name	ComSignalEndianness		
Parent Container	ComGwSourceDescription		
Description	Defines the endianness of the signal's network representation.		
Multiplicity	1		

Type	EcucEnumerationParamDef		
Range	BIG_ENDIAN	--	
	LITTLE_ENDIAN	--	
	OPAQUE	--	
Post-Build Variant Value	true		
Value Configuration Class	Pre-compile time	X	VARIANT-PRE-COMPILE
	Link time	X	VARIANT-LINK-TIME
	Post-build time	X	VARIANT-POST-BUILD
Scope / Dependency	scope: local		

SWS Item	ECUC_Com_00437 :		
Name	ComSignalLength		
Parent Container	ComGwSourceDescription		
Description	Description: For ComSignalType UINT8_N this parameter specifies the length n in bytes. For ComSignalType UINT8_DYN it specifies the maximum length in bytes. For all other types this parameter shall be ignored. The supported maximum length is restricted by the used transportation system. For non TP-PDUs the maximum size of a PDU, and therefore also of any included signal, is limited by the concrete bus characteristic. For example, the limit is 8 bytes for CAN and LIN, 64 bytes for CAN FD and 254 for FlexRay.		
Multiplicity	0..1		
Type	EcucIntegerParamDef		
Range	0 .. 4294967295		
Default value	--		
Post-Build Variant Multiplicity	false		
Post-Build Variant Value	false		
Multiplicity Configuration Class	Pre-compile time	X	VARIANT-PRE-COMPILE
	Link time	X	VARIANT-LINK-TIME, VARIANT-POST-BUILD
	Post-build time	--	
Value Configuration Class	Pre-compile time	X	VARIANT-PRE-COMPILE
	Link time	X	VARIANT-LINK-TIME, VARIANT-POST-BUILD
	Post-build time	--	
Scope / Dependency	scope: local		

SWS Item	ECUC_Com_00127 :		
Name	ComSignalType		
Parent Container	ComGwSourceDescription		
Description	The AUTOSAR type of the signal. Whether or not the signal is signed or unsigned can be found by examining the value of this attribute. This type could also be used to reserved appropriate storage in AUTOSAR COM.		
Multiplicity	1		
Type	EcucEnumerationParamDef		
Range	BOOLEAN	--	
	FLOAT32	--	
	FLOAT64	--	
	SINT16	--	
	SINT32	--	
	SINT64	--	
	SINT8	--	

	UINT16	--	
	UINT32	--	
	UINT64	--	
	UINT8	--	
	UINT8_DYN	--	
	UINT8_N	--	
Post-Build Variant Value	false		
Value Configuration Class	Pre-compile time	X	VARIANT-PRE-COMPILE
	Link time	X	VARIANT-LINK-TIME, VARIANT-POST-BUILD
	Post-build time	--	
Scope / Dependency	scope: local		

SWS Item	ECUC_Com_00257 :		
Name	ComUpdateBitPosition		
Parent Container	ComGwSourceDescription		
Description	Bit position of update-bit inside I-PDU. If this attribute is omitted then there is no update-bit. This setting must be consistently on sender and on receiver side. Range: 0..63 for CAN and LIN, 0..511 for CAN FD, 0..2031 for FlexRay, 0..4294967295 for TP.		
Multiplicity	0..1		
Type	EcucIntegerParamDef		
Range	0 .. 4294967295		
Default value	--		
Post-Build Variant Multiplicity	true		
Post-Build Variant Value	true		
Multiplicity Configuration Class	Pre-compile time	X	VARIANT-PRE-COMPILE
	Link time	X	VARIANT-LINK-TIME
	Post-build time	X	VARIANT-POST-BUILD
Value Configuration Class	Pre-compile time	X	VARIANT-PRE-COMPILE
	Link time	X	VARIANT-LINK-TIME
	Post-build time	X	VARIANT-POST-BUILD
Scope / Dependency	scope: local		

SWS Item	ECUC_Com_00550 :		
Name	ComGwIPduRef		
Parent Container	ComGwSourceDescription		
Description	Reference to an I-PDU of a Signal Gateway source or destination description.		
Multiplicity	1		
Type	Reference to [ComIPdu]		
Post-Build Variant Value	true		
Value Configuration Class	Pre-compile time	X	VARIANT-PRE-COMPILE
	Link time	X	VARIANT-LINK-TIME
	Post-build time	X	VARIANT-POST-BUILD
Scope / Dependency			

No Included Containers

10.1.21 ComGwDestination

SWS Item	ECUC_Com_00546 :		
Choice container Name	ComGwDestination		
Description	Each instance of this choice container allows to define one routing destination either by reference to an already configured COM signal / group signal or by a destination description container.		
Post-Build Variant Multiplicity	true		
Multiplicity Configuration Class	Pre-compile time	X	VARIANT-PRE-COMPILE
	Link time	X	VARIANT-LINK-TIME
	Post-build time	X	VARIANT-POST-BUILD

Container Choices		
Container Name	Multiplicity	Scope / Dependency
ComGwDestinationDescription	0..1	Description of a gateway destination. This container allows defining a gateway destination without the configuration of a complete COM signal. This allows adding / changing gateway relations post build without the configuration of new signals.
ComGwSignal	0..1	This container allows specifying a gateway source or destination respectively with a reference to a ComSignal or a ComGroupSignal.

10.1.22 ComGwDestinationDescription

SWS Item	ECUC_Com_00549 :		
Container Name	ComGwDestinationDescription		
Description	Description of a gateway destination. This container allows defining a gateway destination without the configuration of a complete COM signal. This allows adding / changing gateway relations post build without the configuration of new signals.		
Configuration Parameters			

SWS Item	ECUC_Com_00259 :		
Name	ComBitPosition		
Parent Container	ComGwDestinationDescription		
Description	Starting position within the I-PDU. This parameter refers to the position in the I-PDU and not in the shadow buffer. If the endianness conversion is configured to Opaque the parameter ComBitPosition shall define the bit0 of the first byte like in little endian byte order		
Multiplicity	1		
Type	EcucIntegerParamDef		
Range	0 .. 4294967295		
Default value	--		
Post-Build Variant Value	true		
Value Configuration Class	Pre-compile time	X	VARIANT-PRE-COMPILE
	Link time	X	VARIANT-LINK-TIME
	Post-build time	X	VARIANT-POST-BUILD
Scope / Dependency	scope: local		

SWS Item	ECUC_Com_00157 :		
Name	ComSignalEndianness		
Parent Container	ComGwDestinationDescription		
Description	Defines the endianness of the signal's network representation.		
Multiplicity	1		
Type	EcucEnumerationParamDef		
Range	BIG_ENDIAN	--	
	LITTLE_ENDIAN	--	
	OPAQUE	--	
Post-Build Variant Value	true		
Value Configuration Class	Pre-compile time	X	VARIANT-PRE-COMPILE
	Link time	X	VARIANT-LINK-TIME
	Post-build time	X	VARIANT-POST-BUILD
Scope / Dependency	scope: local		

SWS Item	ECUC_Com_00170 :		
Name	ComSignalInitValue		
Parent Container	ComGwDestinationDescription		
Description	<p>Initial value for this signal. In case of UINT8_N the default value is a string of length ComSignalLength with all bytes set to 0x00. In case of UINT8_DYN the initial size shall be 0.</p> <p>In case the ComSignalType is UINT8, UINT16, UINT32, UINT64, SINT8, SINT16, SINT32, SINT64 the string shall be interpreted as defined in the chapter Integer Type in the AUTOSAR EcuC specification.</p> <p>In case the ComSignalType is FLOAT32, FLOAT64 the string shall be interpreted as defined in the chapter Float Type in the AUTOSAR EcuC specification.</p> <p>In case the ComSignalType is BOOLEAN the string shall be interpreted as defined in the chapter Boolean Type in the AUTOSAR EcuC specification.</p> <p>In case the ComSignal is a UINT8_N, UINT8_DYN the string shall be interpreted as a decimal representation of the characters separated by blanks, e.g. "97 98 100" means a string "abd", where the char "a" is in byte 0 (lowest address), "b" is in byte 1, and "d" is in byte 2 and (highest address).</p> <p>For the ComSignalType UINT8_DYN the dynamic length shall be set to the number of configured characters. An empty string "" shall be interpreted as 0-sized dynamic signal.</p>		
Multiplicity	0..1		
Type	EcucStringParamDef		
Default value	0		
maxLength	--		
minLength	--		
regularExpression	--		
Post-Build Variant Multiplicity	true		
Post-Build Variant Value	true		
Multiplicity Configuration Class	Pre-compile time	X	VARIANT-PRE-COMPILE
	Link time	X	VARIANT-LINK-TIME
	Post-build time	X	VARIANT-POST-BUILD
Value Configuration Class	Pre-compile time	X	VARIANT-PRE-COMPILE
	Link time	X	VARIANT-LINK-TIME
	Post-build time	X	VARIANT-POST-BUILD
Scope / Dependency	scope: local dependency: In case of UINT8_N the length of ComSignalInitValue has to be the same as ComSignalLength.		

SWS Item	ECUC_Com_00232 :	
Name	ComTransferProperty	
Parent Container	ComGwDestinationDescription	
Description	Defines if a write access to this signal can trigger the transmission of the corresponding I-PDU. If the I-PDU is triggered, depends also on the transmission mode of the corresponding I-PDU.	
Multiplicity	0..1	
Type	EcucEnumerationParamDef	
Range	PENDING	A write access to this signal never triggers the transmission of the corresponding I-PDU.
	TRIGGERED	Depending on the transmission mode, a write access to this signal can trigger the transmission of the corresponding I-PDU.
	TRIGGERED_ON_CHANGE	Depending on the transmission mode, a write access to this signal can trigger the transmission of the corresponding I-PDU, but only in case the written value is different to the locally stored (last sent or initial value) in length or value.
	TRIGGERED_ON_CHANGE_WITHOUT_REPETITION	Depending on the transmission mode, a write access to this signal can trigger the transmission of the corresponding I-PDU just once without a repetition, but only in case the written value is different to the locally stored (last sent or initial value) in length or value.
	TRIGGERED_WITHOUT_REPETITION	Depending on the transmission mode, a write access to this signal can trigger the transmission of the corresponding I-PDU just once without a repetition.
Post-Build Variant Multiplicity	true	
Post-Build Variant Value	true	
Multiplicity Configuration Class	<i>Pre-compile time</i>	X VARIANT-PRE-COMPILE
	<i>Link time</i>	X VARIANT-LINK-TIME
	<i>Post-build time</i>	X VARIANT-POST-BUILD
Value Configuration Class	<i>Pre-compile time</i>	X VARIANT-PRE-COMPILE
	<i>Link time</i>	X VARIANT-LINK-TIME
	<i>Post-build time</i>	X VARIANT-POST-BUILD

Scope / Dependency	scope: local
---------------------------	--------------

SWS Item	ECUC_Com_00257 :		
Name	ComUpdateBitPosition		
Parent Container	ComGwDestinationDescription		
Description	Bit position of update-bit inside I-PDU. If this attribute is omitted then there is no update-bit. This setting must be consistently on sender and on receiver side. Range: 0..63 for CAN and LIN, 0..511 for CAN FD, 0..2031 for FlexRay, 0..4294967295 for TP.		
Multiplicity	0..1		
Type	EcucIntegerParamDef		
Range	0 .. 4294967295		
Default value	--		
Post-Build Variant Multiplicity	true		
Post-Build Variant Value	true		
Multiplicity Configuration Class	Pre-compile time	X	VARIANT-PRE-COMPILE
	Link time	X	VARIANT-LINK-TIME
	Post-build time	X	VARIANT-POST-BUILD
Value Configuration Class	Pre-compile time	X	VARIANT-PRE-COMPILE
	Link time	X	VARIANT-LINK-TIME
	Post-build time	X	VARIANT-POST-BUILD
Scope / Dependency	scope: local		

SWS Item	ECUC_Com_00550 :		
Name	ComGwIPduRef		
Parent Container	ComGwDestinationDescription		
Description	Reference to an I-PDU of a Signal Gateway source or destination description.		
Multiplicity	1		
Type	Reference to [ComIPdu]		
Post-Build Variant Value	true		
Value Configuration Class	Pre-compile time	X	VARIANT-PRE-COMPILE
	Link time	X	VARIANT-LINK-TIME
	Post-build time	X	VARIANT-POST-BUILD
Scope / Dependency			

Included Containers		
Container Name	Multiplicity	Scope / Dependency
ComFilter	0..1	This container contains the configuration parameters of the AUTOSAR COM module's Filters. Note: On sender side the container is used to specify the transmission mode conditions.

10.1.23 ComGwSignal

SWS Item	ECUC_Com_00551 :
Container Name	ComGwSignal
Description	This container allows specifying a gateway source or destination

	respectively with a reference to a ComSignal or a ComGroupSignal.
--	---

Configuration Parameters

SWS Item	ECUC_Com_00547 :		
Name	ComGwSignalRef		
Parent Container	ComGwSignal		
Description	Reference to an object of a gateway relation. Either to a ComSignal or a ComGroupSignal.		
Multiplicity	1		
Type	Choice reference to [ComGroupSignal , ComSignal]		
Post-Build Variant Value	true		
Value Configuration Class	Pre-compile time	X	VARIANT-PRE-COMPILE
	Link time	X	VARIANT-LINK-TIME
	Post-build time	X	VARIANT-POST-BUILD
Scope / Dependency			

No Included Containers

10.2 Configuration Rules

10.2.1 General Rules

[SWS_Com_00401] [It is illegal for any two of the following parameters to have the same value:

- shortName of a ComSignal
- shortName of a ComSignalGroup
- shortName of a ComGroupSignal
- shortName of a ComIPdu
- shortName of a ComIPduGroup

] (SRS_Com_02067)

[SWS_Com_00732] [It is illegal for any of the following five parameters:

- ComNotification
- ComErrorNotification
- ComTimeoutNotification
- ComInvalidNotification
- ComIPduCallout

to have the same value as any of the following five parameters

- Com_<shortName of a ComSignal>
- Com_<shortName of a ComSignalGroup>
- Com_<shortName of a ComGroupSignal>
- Com_<shortName of a ComIPdu>
- Com_<shortName of a ComIPduGroup>

] (SRS_Com_02067)

[SWS_Com_00402] [It is illegal for any of the following parameters not to be formulated according to C's identifier rules:

- shortName of a ComSignal
- shortName of a ComSignalGroup
- shortName of a ComGroupSignal
- shortName of a ComIPdu
- shortName of a ComIPduGroup
- ComNotification
- ComErrorNotification
- ComTimeoutNotification
- ComInvalidNotification
- ComIPduCallout

] (SRS_Com_02067)

10.2.2 Signal Configuration

More than one signal can be packed into an I-PDU as long as the following packing rules are fulfilled:

[SWS_Com_00102] [ComSignal/ ComGroupSignal are not allowed to overlap each other.] (SRS_Com_02067)

It is explicitly allowed that a ComSignal/ ComGroupSignal may have the size 0, see ECUC_Com_00158.

A signal of size 0 never overlaps other signals. Therefore, it can be configured to an arbitrary position within the I-PDU. The position of a zero sized signal is only relevant in case receiving an I-PDU partially.

[SWS_Com_00105] [ComSignal/ ComGroupSignal of ComSignalType UINT8_N and UINT8_DYN shall be byte aligned (ComBitPosition is a multiple of 8).] (SRS_Com_02067)

[SWS_Com_00443] [A ComSignal/ ComGroupSignal of type uint8[n] shall always be mapped to an n-bytes sized ComSignal/ ComGroupSignal.] (SRS_Com_02067)

[SWS_Com_00553] [A ComSignal/ ComGroupSignal of type uint8[n] shall be configured to have OPAQUE endianness.] (SRS_Com_02067)

[SWS_Com_00754] [A dynamic length I-PDU shall contain at most one dynamic length signal.] (SRS_Com_02091, SRS_Com_02092)

[SWS_Com_00755] [The dynamic length signal shall be placed last in a dynamic length I-PDU.] (SRS_Com_02091, SRS_Com_02093)

[SWS_Com_00756] [The ComSignalLength parameter shall be configured to the maximum size/ length for dynamic length signals.] (SRS_Com_02091, SRS_Com_02097)

[SWS_Com_00310] [For I-PDUs with transmission mode *DIRECT* or *MIXED* with ComTxModeNumberOfRepetitions greater or equal 1 no update-bit (ComUpdateBit-Position) shall be configured.](SRS_Com_02067, SRS_Com_02030)

[SWS_Com_00785] [The ComBitSize of a (group) signal shall not extend past the size of its configured ComSignalType.] (SRS_Com_02067)

For example, the ComBitSize of a signal with ComSignalType UINT8 shall not exceed 8 bits.

[SWS_Com_00790] [The configured string of ComSignalInitValues/ ComSignalDataInvalidValue shall be interpreted according to the definitions of [22] for the boolean and all numerical types.] (SRS_Com_02067)

[SWS_Com_00859] [In case a ComSignalDataInvalidValue is configured for a ComSignal that is included in a ComIPdu with ComIPduDirection *RECEIVE*, the ComDataInvalidAction shall also be configured for this ComSignal.] (SRS_Com_02079, SRS_Com_02087)

10.2.3 Signal Group Configuration

[SWS_Com_00365] [It shall not be allowed to configure signal groups for routing with data type differences between receive and transmit signal group. A sub-setting of signal groups (as defined in SWS_Com_00735) shall be supported.] (SRS_Com_02067)

How the signals of signal groups are placed within an I-PDU is not restricted. It is allowed to define interlaced signal groups, or to place other signals within the wholes of a signal group.

[SWS_Com_00860] [In case a ComSignalDataInvalidValue is configured for at least one ComGroupSignal of a ComSignalGroup that is included in a ComIPdu with ComIPduDirection *RECEIVE*, the ComDataInvalidAction shall also be configured for this ComSignalGroup.] (SRS_Com_02079, SRS_Com_02087)

10.2.4 Transmission Mode Configuration

[SWS_Com_00465] [Every ComTxModeTrue or ComTxModeFalse that is a potential result of the configured/ calculated TMS must be configured. Within the ComTxIPdu, at least one of the containers ComTxModeTrue or ComTxModeFalse has to be included.] (SRS_Com_02067)

10.2.5 Signal Gateway Configuration

[SWS_Com_00384] [The ComBitSize of a received and to be routed ComSignal shall not differ.] (SRS_Com_02067)

[SWS_Com_00598] [A signal or signal group contained in an I-PDU with ComIPdu-Type configured as TP shall not be configured as source or destination within the ComGwMapping configuration container.] (SRS_PduR_06055)

Additionally to reception deadline monitoring of a ComSignal, to be routed by the Signal Gateway, it is possible to configure update-bits via ComUpdateBitPosition, for the transmit signal. In this case, the receiving node can detect if the sender has really updated the signal or it is just repeated by the Signal Gateway. If this is necessary depends on the use-case.

10.2.6 Filter Configuration

[SWS_Com_00535] [For the ComFilterAlgorithm *ONE_EVERY_N*, the ComFilterOffset shall be configured to a value lesser than ComFilterPeriod.] (SRS_Com_02067)

10.2.7 Post Build Configuration

[SWS_Com_00373] [The post-build time configuration part (post-compile and post-link time) can only be updated when it is not in use.] (SRS_Com_02067, SRS_PduR_06002)

[SWS_Com_00487] [The complete post-build time configurable configuration shall be identifiable by a unique identifier.] (SRS_PduR_06097)

10.2.8 Dynamic Length I-PDUs

[SWS_Com_00817] [I-PDUs including metadata shall not be configured as dynamic length I-PDUs.] (SRS_Com_02067)

The above restriction is necessary, since the length of the dynamic length signal could not be derived correctly, when the I-PDU contains additional metadata.

Since the FlexRay Interface does only support even values for the I-PDU length, it is not recommend to configure dynamic length I-PDU to be send via FrIf. Instead, the FlexRay TP module should be used to transport dynamic length I-PDUs via FlexRay.

10.2.9 Replicated I-PDUs

[SWS_Com_00834] [If an I-PDU is configured for replication (includes a ComIPduReplication), this I-PDU shall also have configured an I-PDU counter (ComIPduCounter) with a counter threshold (ComIPduCounterThreshold) set to 0.] (SRS_Com_02102)

For further information on this constraint see 7.10.

10.2.10 I-PDU group

[SWS_Com_00871] [All I-PDUs that are contained within one I-PDU group shall have the same ComIPduDirection.] (SRS_Com_00218)

Since the nesting of I-PDU groups is only conceptual (see Chapter 7.3.5.1), the above requirements restricts also all nested I-PDU groups to have the same ComIPduDirection.

11 Not Applicable Requirements

[SWS_Com_00999] [These requirements are not applicable to this specification.]
(SRS_BSW_00171, SRS_BSW_00170, SRS_BSW_00383, SRS_BSW_00375,
SRS_BSW_00416, SRS_BSW_00437, SRS_BSW_00168, SRS_BSW_00423,
SRS_BSW_00424, SRS_BSW_00426, SRS_BSW_00427, SRS_BSW_00428,
SRS_BSW_00429, SRS_BSW_00433, SRS_BSW_00417, SRS_BSW_00409,
SRS_BSW_00386, SRS_BSW_00161, SRS_BSW_00162, SRS_BSW_00005,
SRS_BSW_00164, SRS_BSW_00325, SRS_BSW_00413, SRS_BSW_00347,
SRS_BSW_00307, SRS_BSW_00410, SRS_BSW_00314, SRS_BSW_00353,
SRS_BSW_00361, SRS_BSW_00302, SRS_BSW_00328, SRS_BSW_00006,
SRS_BSW_00378, SRS_BSW_00306, SRS_BSW_00308, SRS_BSW_00309,
SRS_BSW_00009, SRS_BSW_00010, SRS_BSW_00333, SRS_BSW_00321,
SRS_BSW_00341, SRS_BSW_00334)

12 Appendix A

This appendix contains use cases with different transmission modes and the necessary configuration for these. Table 10 shows the notation of the use case diagrams.



Notation	Description
t_c, t_{c1}, t_{c2}	cycle times
t_d	cycle time of N-Times sent signals
t_r	minimum SW reaction time of COM-Layer due to internal main cycle time
V	Value: x stands for an arbitrary value/ value range, a...w for specific values / value ranges, defined by the user, with $a <> b$, range a is disjoint from range b.
	request from RTE to the COM-Layer
	request from COM-Layer to PDU Router
	potential but skipped request from COM-Layer to PDU Router (e.g. because of a new send request by the RTE or delayed due to minimum delay time)
dt	minimum delay time: minimum distance between two requests to PDU Router
without TMS switch	without switching of the TMS (see 7.3.3.2) from true to false or vice versa
with TMS switch	with switching of the TMS (see 7.3.3.2) from true to false or vice versa (from TM 1 to TM 2); one TM is named before the "+" and one behind in the description

Table 10: Legend for use case diagrams.

Use case 1 shows an I-PDU that is sent out cyclically with a cycle time t_c . This I-PDU consists of signals that all have the ComTransferProperty *PENDING*. It is configured that the transmission takes place when the TMS evaluates to true.

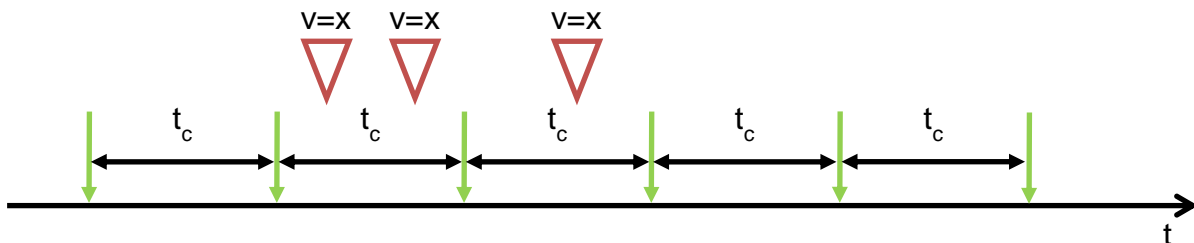

Figure 10: Use case 1, TM periodic (without TMS switch, see Chapter 7.3.3.2)

ComSignal	
ComTransferProperty	PENDING or TRIGGERED (TRIGGERED has no influence)
ComFilter	
ComFilterAlgorithm	ALWAYS

ComIPdu	
ComIPduDirection	SEND
ComTxModeTrue	
ComTxModeTimePeriod	tc
ComTxModeMode	PERIODIC
ComTxIPdu	
ComMinimumDelayTime	0 or omitted

Table 11: Relevant I-PDU transmission configuration for use case 1

Because of the configuration of the parameter *ComFilterAlgorithm ALWAYS* of the *ComFilter*, there is no need to configure a transmission mode for the case that the TMS evaluates to false.

It does not make any difference in the behavior whether the *ComFilterAlgorithm* parameter of the *ComFilter* is set for all the signals within the I-PDU to *ALWAYS* or if the *ComFilter* is not defined (does not contribute to the evaluation of the TMS), see SWS_Com_00255.

Use case 2 shows an I-PDU which is sent out three times whenever a value is given by the upper (Com_SendSignal or Com_SendSignalGroup). The time between two transmissions is t_d . This I-PDU consists of signals, which all have the ComTransfer-Property *TRIGGERED*. It is configured that the transmission takes place when the TMS evaluates to true.

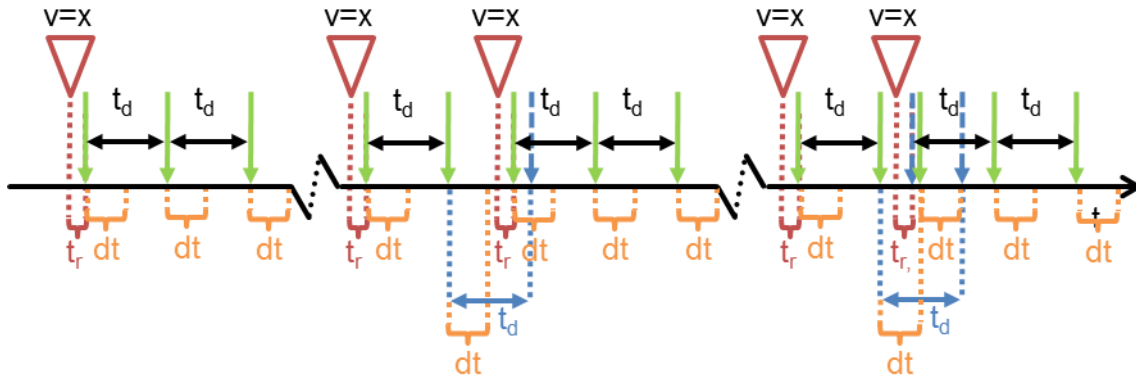

Figure 11: Use case 2, TM DIRECT (N-Times) here n = 2 (without TMS switch)

ComGeneral	
<i>ComEnableMDTForCyclicTransmission</i>	true
ComSignal	
<i>ComTransferProperty</i>	TRIGGERED
ComFilter	
<i>ComFilterAlgorithm</i>	ALWAYS
ComIPdu	
<i>ComIPduDirection</i>	SEND
<i>ComTxModeTrue</i>	
<i>ComTxModeMode</i>	DIRECT
<i>ComTxModeNumberOfRepetitions</i>	2
<i>ComTxModeRepetitionPeriod</i>	t_d
ComTxIPdu	
<i>ComMinimumDelayTime</i>	dt

Table 12: Relevant I-PDU transmission configuration for use case 2

If there is a new send request by the RTE before the ongoing repetition cycle is completed, the new repetition cycle is started and the rest of the last one is discarded.

Use case 3 shows an I-PDU which is send out cyclically with a cycle time t_{c1} if value $v = a$ (TMS evaluates to true) and with a cycle time t_{c2} if value $v = b$ (TMS evaluates to false). The I-PDU consists of signals, which all have the ComTransferProperty *PENDING*.

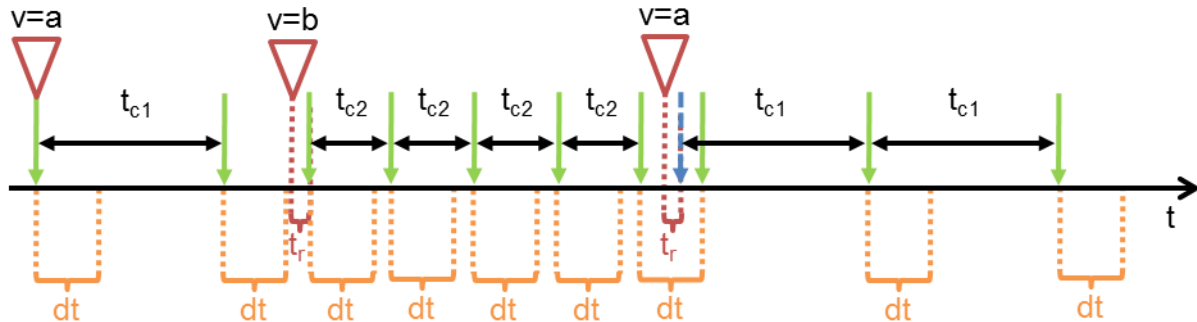

Figure 12: Use case 3, TM periodic + periodic (with TMS switch)

ComGeneral	
ComEnableMDTForCyclicTransmission	true
ComSignal	
ComTransferProperty	PENDING or TRIGGERED (TRIGGERED has no influence)
ComFilter	
ComFilterAlgorithm	any filter mapping value a to true and value b to false
ComIPdu	
ComIPduDirection	SEND
ComTxModeTrue	
ComTxModeMode	PERIODIC
ComTxModeTimePeriod	t_{c1}
ComTxModeFalse	
ComTxModeMode	PERIODIC
ComTxModeTimePeriod	t_{c2}
ComTxIPdu	
ComMinimumDelayTime	dt

Table 13: Relevant I-PDU transmission configuration for use case 3

The TMS switch caused by the new value $v = b$, starts a new cycle within the next main function and the new value is sent out. Nevertheless, the minimum delay time dt has to be taken into account, since ComEnableMDTForCyclicTransmission is set to true.

For the parameter ComFilterAlgorithm, the following filters defined in [17] can be used for this use-case:

- MASKED_NEW_EQUALS_X
- MASKED_NEW_DIFFERS_X
- MASKED_NEW_DIFFERS_MASKED_OLD
- NEW_IS_WITHIN
- NEW_IS_OUTSIDE

Use case 4 shows an I-PDU which is send out cyclically with a cycle time t_c if value $v = a$ (TMS evaluates to true) and if value $v = b$ (TMS evaluates to false) it is sent out three times whenever the value is given by the RTE. The time between two transmissions is t_d . The I-PDU consists of signals that all have the ComTransferProperty *TRIGGERED*.

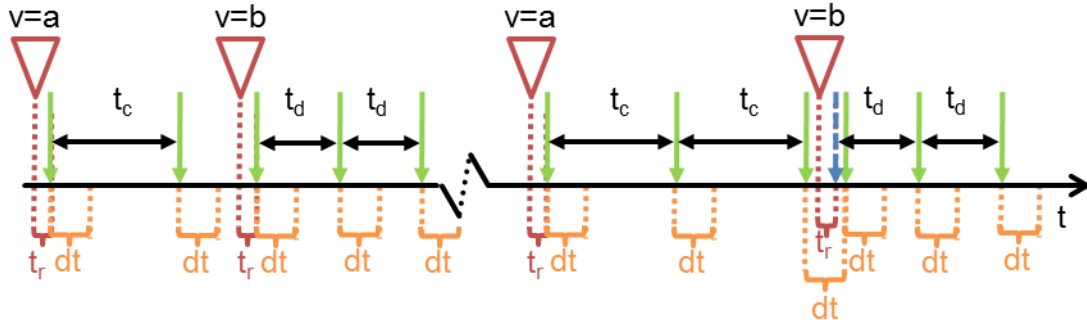

Figure 13: Use case 4 scenario a, TM periodic + *DIRECT/N*-Times, here $n = 2$ (with TMS switch)

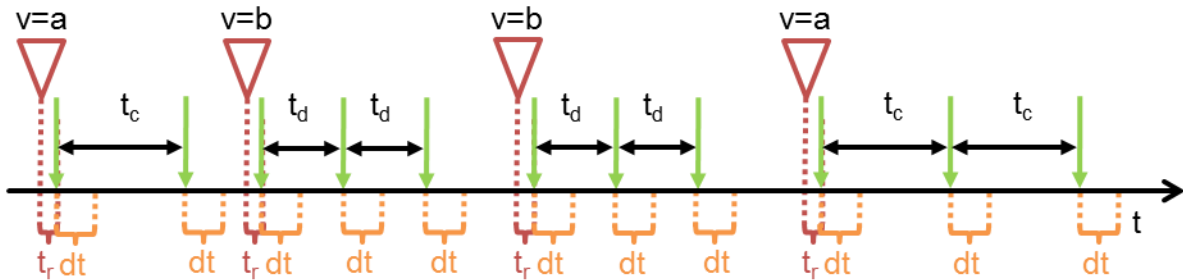

Figure 14: Use case 4 scenario b, TM periodic + *DIRECT/N*-Times, here $n = 2$ (with TMS switch)

ComGeneral	
<i>ComEnableMDTForCyclicTransmission</i>	True
ComSignal	
<i>ComTransferProperty</i>	TRIGGERED
<i>ComFilter</i>	
<i>ComFilterAlgorithm</i>	any filter mapping value a to true and value b to false
ComIPdu	
<i>ComIPduDirection</i>	SEND
<i>ComTxModeTrue</i>	
<i>ComTxModeMode</i>	PERIODIC
<i>ComTxModeTimePeriod</i>	t_c
<i>ComTxModeFalse</i>	
<i>ComTxModeMode</i>	DIRECT
<i>ComTxModeNumberOfRepetitions</i>	2
<i>ComTxModeRepetitionPeriod</i>	t_d
ComTxIPdu	
<i>ComMinimumDelayTime</i>	dt

Table 14: Relevant I-PDU transmission configuration for use case 4

After the switch from ComTxModeMode *DIRECT* to *PERIODIC* the cycle is started within the next main function and the new value *a* is sent out with respect to ComMinimumDelayTime *dt*.

Use case 5 shows an I-PDU which is send out cyclically with a cycle time t_c and if the value (the same or a new one) is given by the RTE it is also sent out directly three times. The time between two of these three transmissions is always t_d . The I-PDU consists of signals that all have the ComTransferProperty *TRIGGERED*.

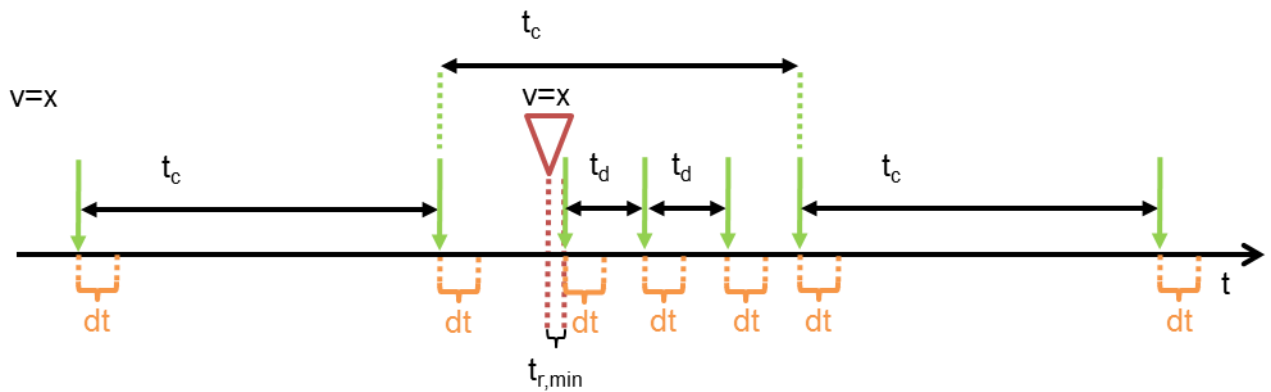

Figure 15: Use case 5 scenario a, TM *MIXED*, here $n = 2$ (without TMS switch)

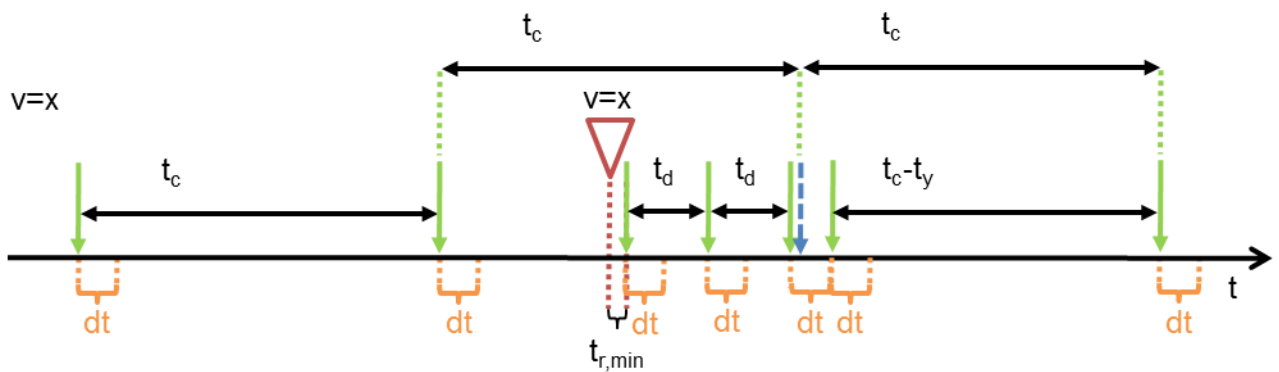

Figure 16: Use case 5 scenario b, TM *MIXED*, here $n = 2$ (without TMS switch)

ComGeneral	
ComEnableMDTForCyclicTransmission	true
ComSignal	
ComTransferProperty	TRIGGERED
ComFilter	
ComFilterAlgorithm	ALWAYS
ComIPdu	
ComIPduDirection	SEND
ComTxModeTrue	
ComTxModeMode	MIXED
ComTxModeTimePeriod	t_c

ComTxModeNumberOfRepetitions	2
ComTxModeRepetitionPeriod	t_d
ComTxIPdu	
ComMinimumDelayTime	dt

Table 15: Relevant I-PDU transmission configuration for use case 5

If the next transmission caused by the periodic part of the ComTxModeMode *MIXED* should take place within the timeout dt (ComMinimumDelayTime) after a transmission of the *DIRECT* (N-Times) part, this sent out is delayed until the minimum delay time is elapsed. However, after that the next period of the periodic part is shortened so that there is only an intermediate phase shift of the periodic part but no continuous one.

Use case 6 shows an I-PDU which is send out cyclically with a cycle time t_{c2} if value $v = b$ (TMS evaluates to false). If value $v = a$ (TMS evaluates to true) it is sent out cyclically with a cycle time t_{c1} and whenever the value $v = a$ is given by the RTE it is also sent out directly three times. The time between two of these three transmissions is always t_d . The I-PDU consists of signals that all have the ComTransferProperty *TRIGGERED*.

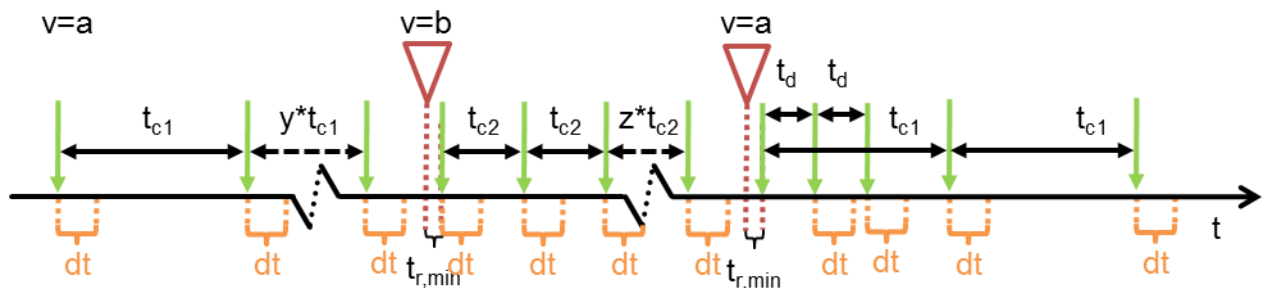
 Figure 17: Use Case 6, TM *MIXED*, here $n = 2 + \text{periodic}$ (with TMS switch)

ComGeneral	
ComEnableMDTForCyclicTransmission	true
ComSignal	
ComTransferProperty	TRIGGERED
ComFilter	
ComFilterAlgorithm	any filter mapping value a to true and value b to false
ComIPdu	
ComIPduDirection	SEND
ComTxModeTrue	
ComTxModeMode	MIXED
ComTxModeTimePeriod	t_{c1}
ComTxModeNumberOfRepetitions	2
ComTxModeRepetitionPeriod	t_d
ComTxModeFalse	
ComTxModeMode	PERIODIC
ComTxModeTimePeriod	t_{c2}
ComTxIPdu	
ComMinimumDelayTime	dt

Table 16: Relevant I-PDU transmission configuration for use case 6

A usage of this in practice is for example the signal of the button that controls the window-lift motor. If the button is not pressed, there is a long cycle time t_{c1} with this information. If it is pressed this information is distributed with a short cycle time t_{c2} . If the button is released again, starting with the next main function this information is distributed three times with t_d and after that, again the long cycle time is used.

Use case 7 is similar to use case 5 but with ComEnableMDTForCyclicTransmission disabled and ComTxModeNumberOfRepetitions set to one.

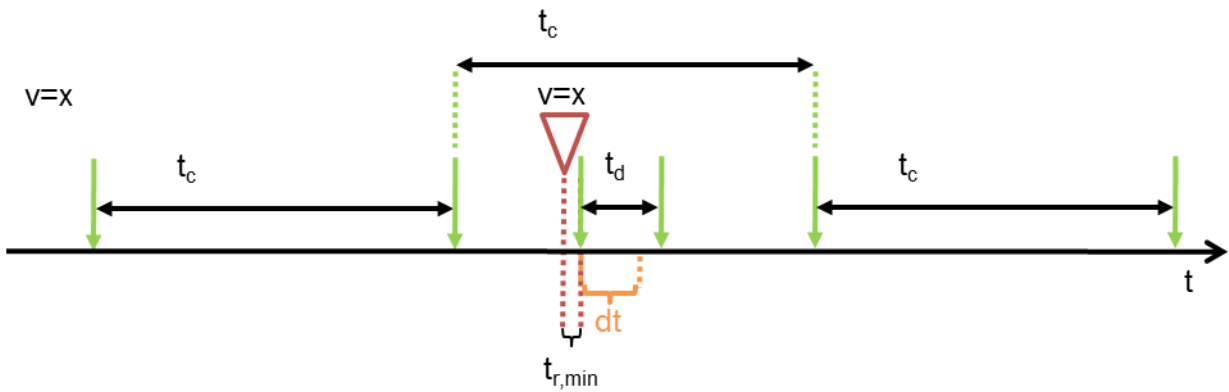

Figure 18: Use case 7 scenario a, TM MIXED, here $n = 1$ (without TMS switch)

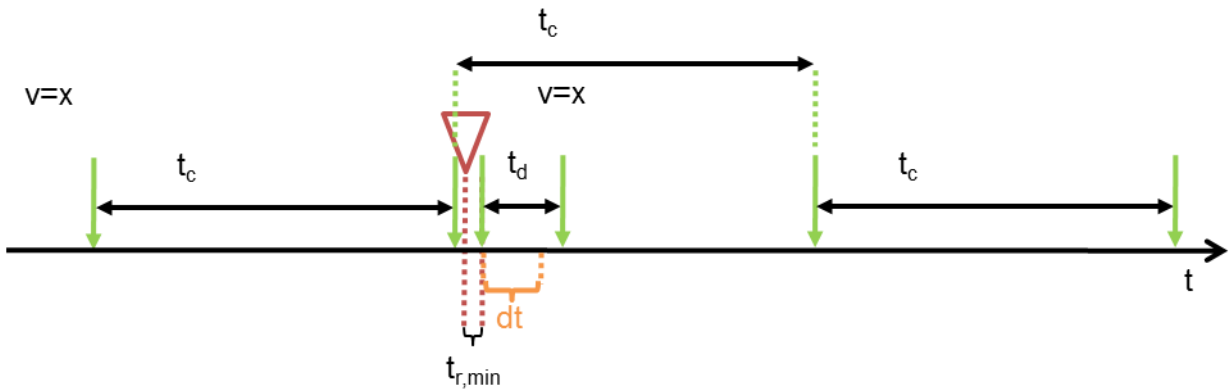

Figure 19: Use case 7 scenario b, TM MIXED, here $n = 1$ (without TMS switch)

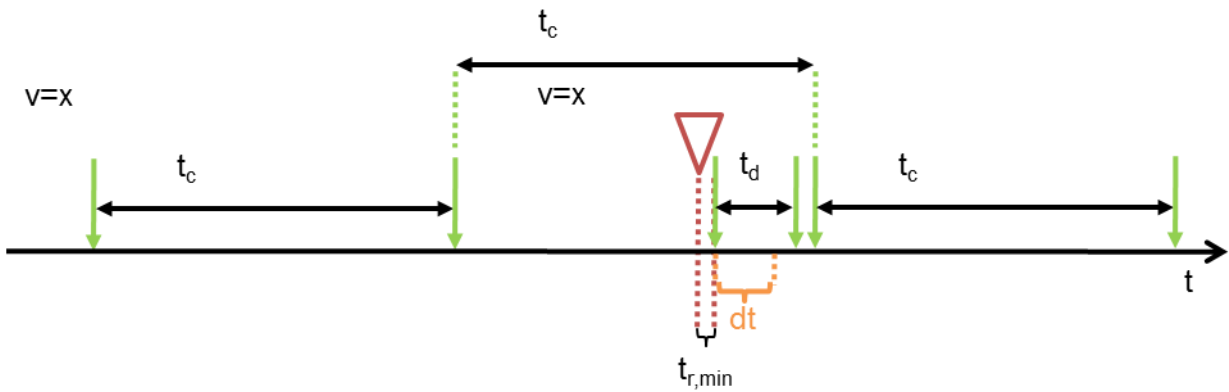

Figure 20: Use case 7 scenario c, TM MIXED, here n = 1 (without TMS switch)

ComGeneral	
<i>ComEnableMDTForCyclicTransmission</i>	False
ComSignal	
<i>ComTransferProperty</i>	TRIGGERED
ComFilter	
<i>ComFilterAlgorithm</i>	ALWAYS
ComIPdu	
<i>ComIPduDirection</i>	SEND
<i>ComTxModeTrue</i>	
<i>ComTxModeMode</i>	MIXED
<i>ComTxModeTimePeriod</i>	t_c
<i>ComTxModeNumberOfRepetitions</i>	1
<i>ComTxModeRepetitionPeriod</i>	t_d
ComTxIPdu	
<i>ComMinimumDelayTime</i>	dt

Table 17: Relevant I-PDU transmission configuration for use case 7

In contrary to use case 5, here the minimum delay timer is neither started for the periodic transmissions of the cyclic part nor for the repeated transmissions of the direct part of the Mixed mode. This can result in two consecutive transmissions within the timespan dt as shown in the scenarios b and c.