



## WP-R-JP – Autosar Regional Work Package in Japan – Pilot for Regional Activity

M. Goto, H. Iwai, K. Hontani

Oct. 29<sup>th</sup> 2015

8<sup>th</sup> AOC, Tokyo

BMW Group



**BOSCH**

**Continental**

**DAIMLER**



PSA PEUGEOT CITROËN

**TOYOTA**

**VOLKSWAGEN**

AKTIENGESELLSCHAFT

## Regional-WP Objectives

- Foster AUTOSAR as a global standard
- Make the participation for partners in the regions China, India, Japan and US more attractive. That means:
  - Make F2F-Meetings easier
  - Cover local / regional requirements
  - Motivate our regional partners to join and support the standardization process
- Variants of the standard must not be created
- The working model between the current WPs and the regional WPs but also between the support functions and the regional WPs has to be defined

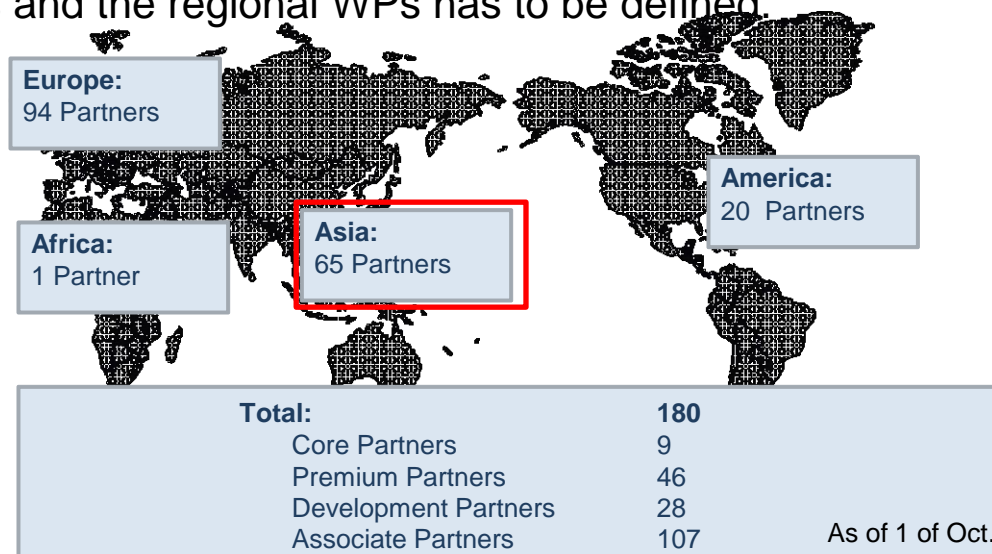

## AUTOSAR in Japan today

- ✓ Well established cooperation with JasPar
- ✓ High number of Partner companies
- ✓ Exploitation of AUTOSAR in series started
- ✓ The cooperation with JasPar has been the base for aligning the AUTOSAR strategy to attend Japanese market

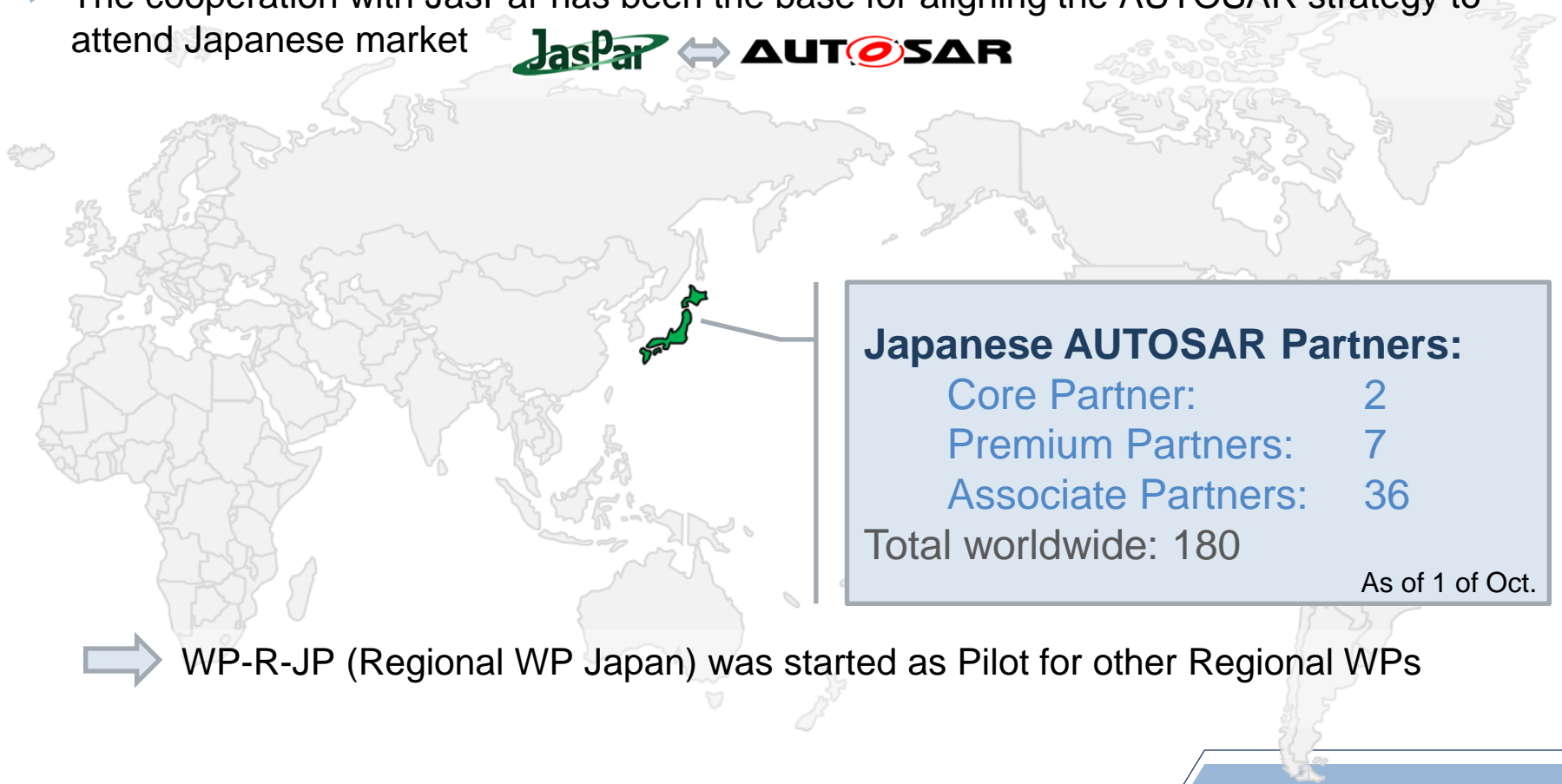

➔ WP-R-JP (Regional WP Japan) was started as Pilot for other Regional WPs

**Partners in Japan need an improved frame-work to work-out regional requirements into AUTOSAR**

- Distance constrains contribution to standardization activities:
  - Currently most AUTOSAR work-package meetings are organized in Europe.
  - But Japanese Partners would like to involve local experts in these activities.
  
- Missing dedicated work-group and interface within AUTOSAR to work on subjects addressed by Japanese Partners:
  - Through cooperation with JasPar, many new requirements are known.
  - But a group to dedicate the work on these subjects is missing within AUTOSAR.

To strengthen AUTOSAR as a global standard, the Partnership is creating additional, regional work-packages to better support the regional markets

# Cooperation between WP-R-JP and JasPar

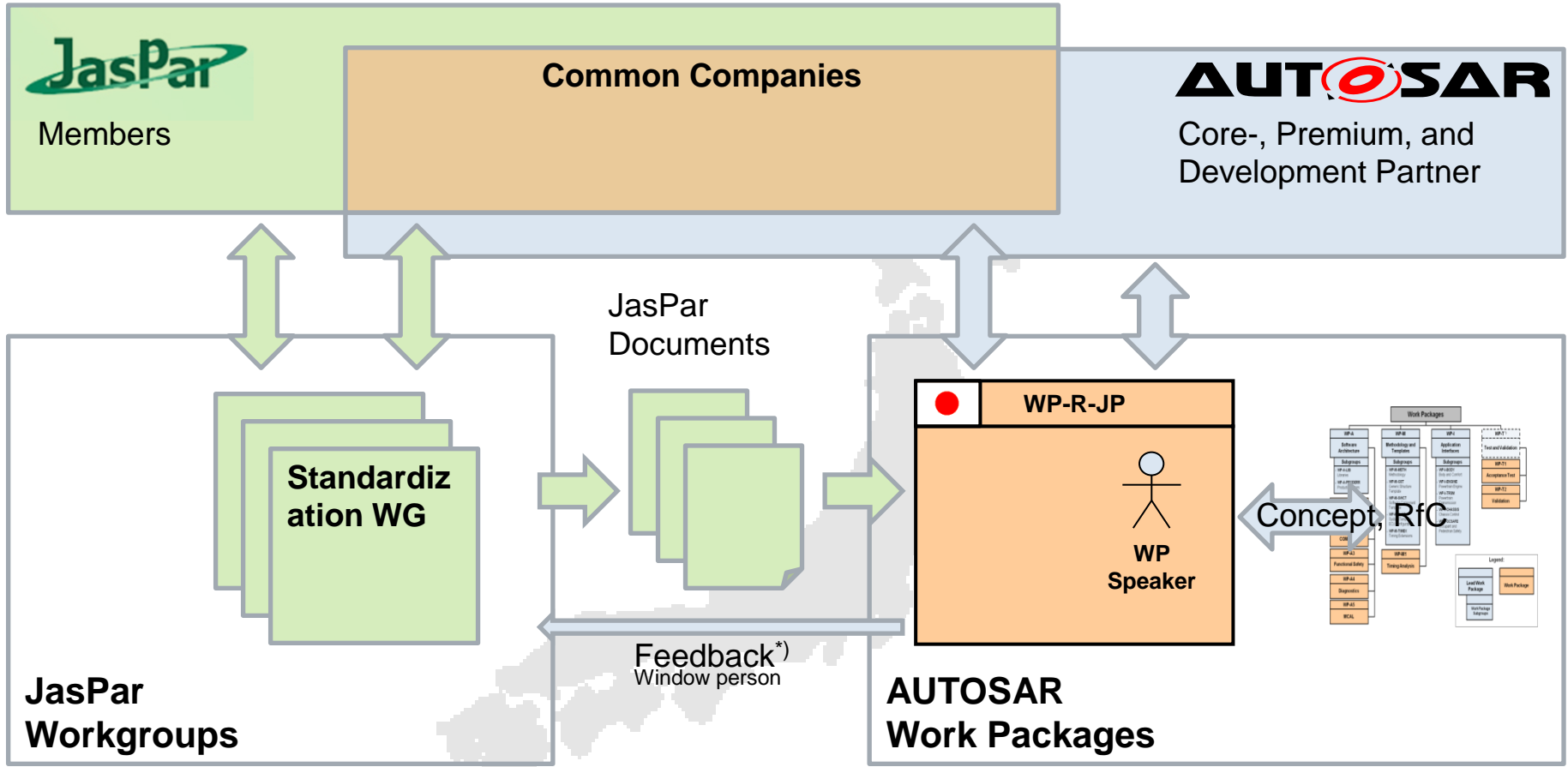

**Regional work package consolidates JasPar and AUTOSAR requirements.**

\*Note: AUTOSAR communication is ruled by AUTOSAR processes.

# Regional Work Packages

## Internal relationship with other regular Autosar WPs

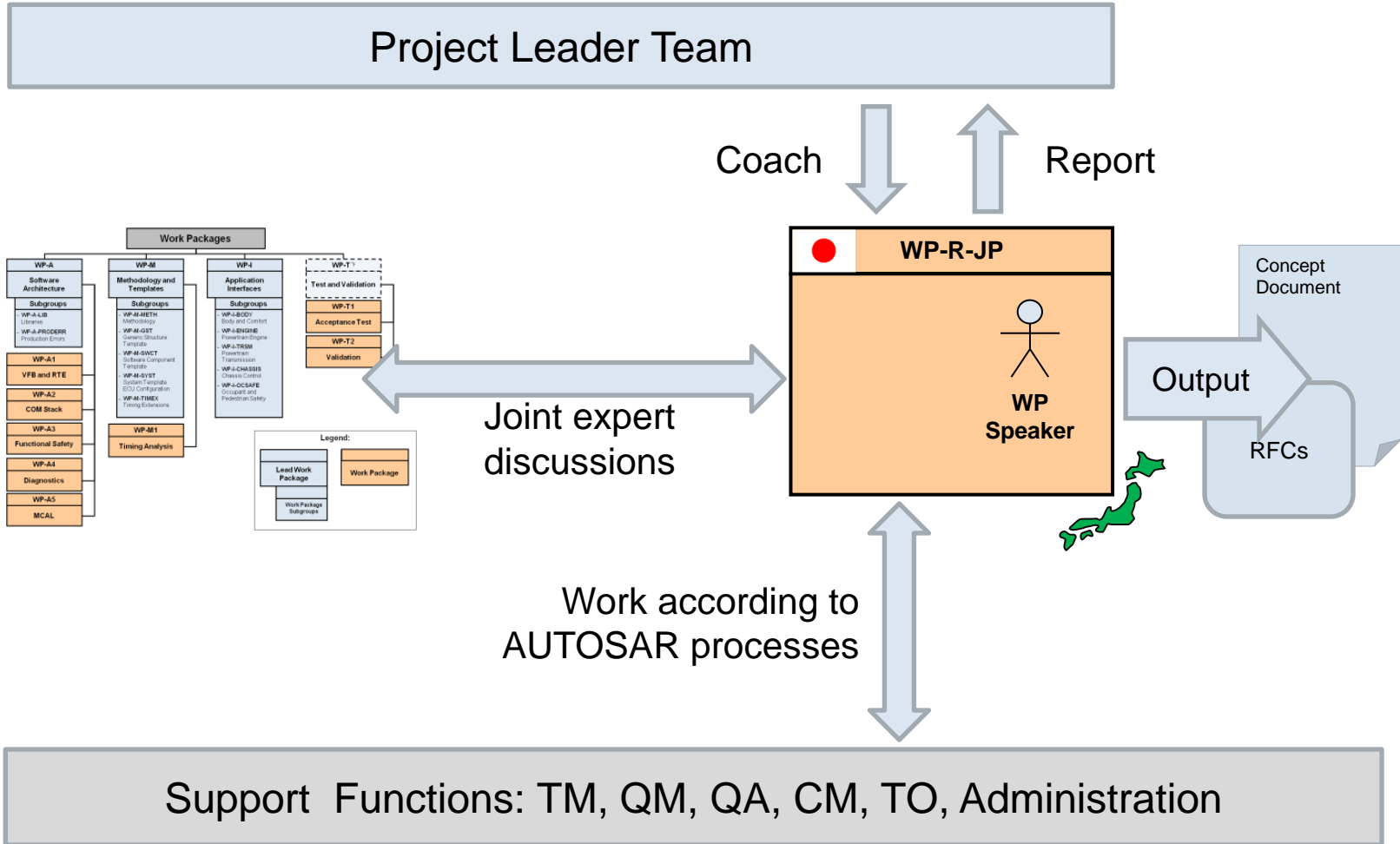

# Organization

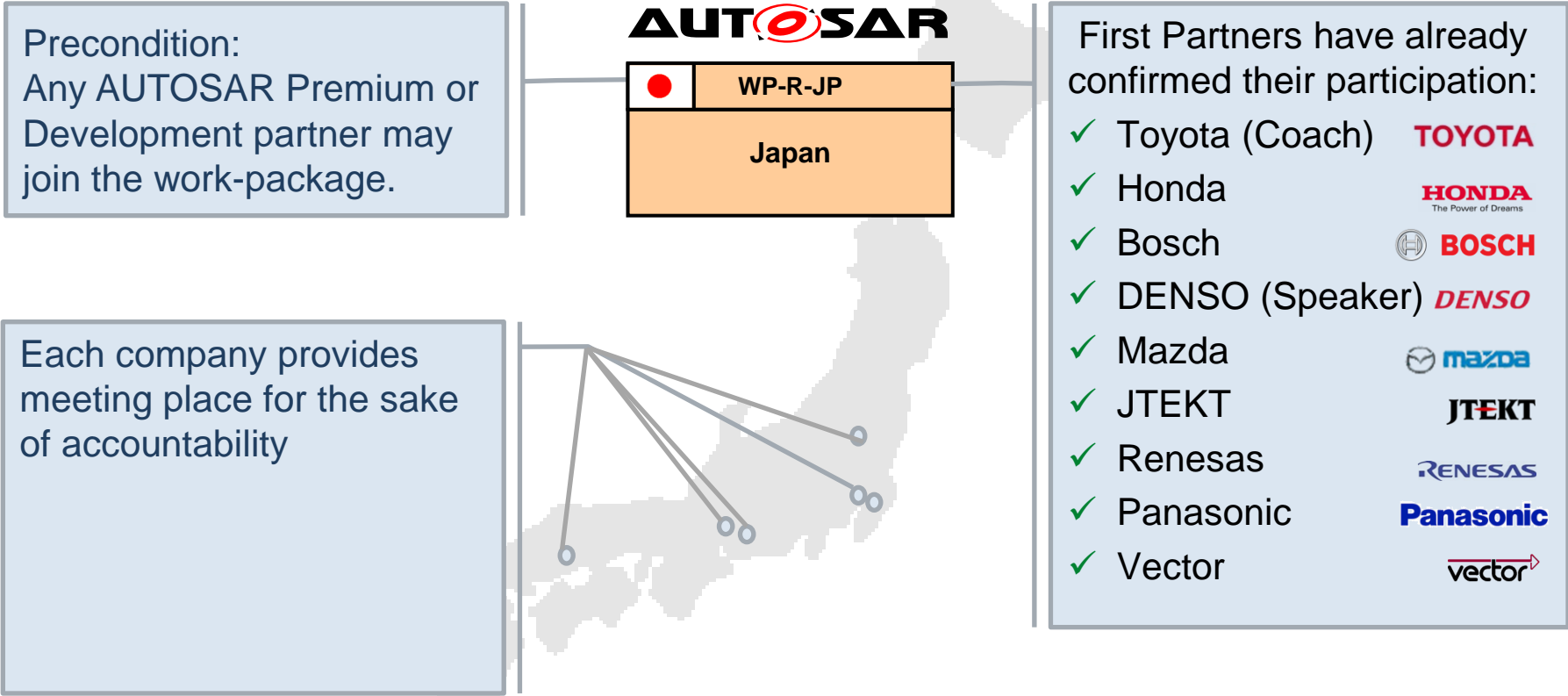

**All premium partners in Japan has been invited and joined**

## Motivation & Goal

- Facilitate local contribution of Japanese companies to AUTOSAR.
- Enhance the interface between AUTOSAR and JasPar activities.
- Work-out requirements and concepts from Japanese Partners into AUTOSAR.

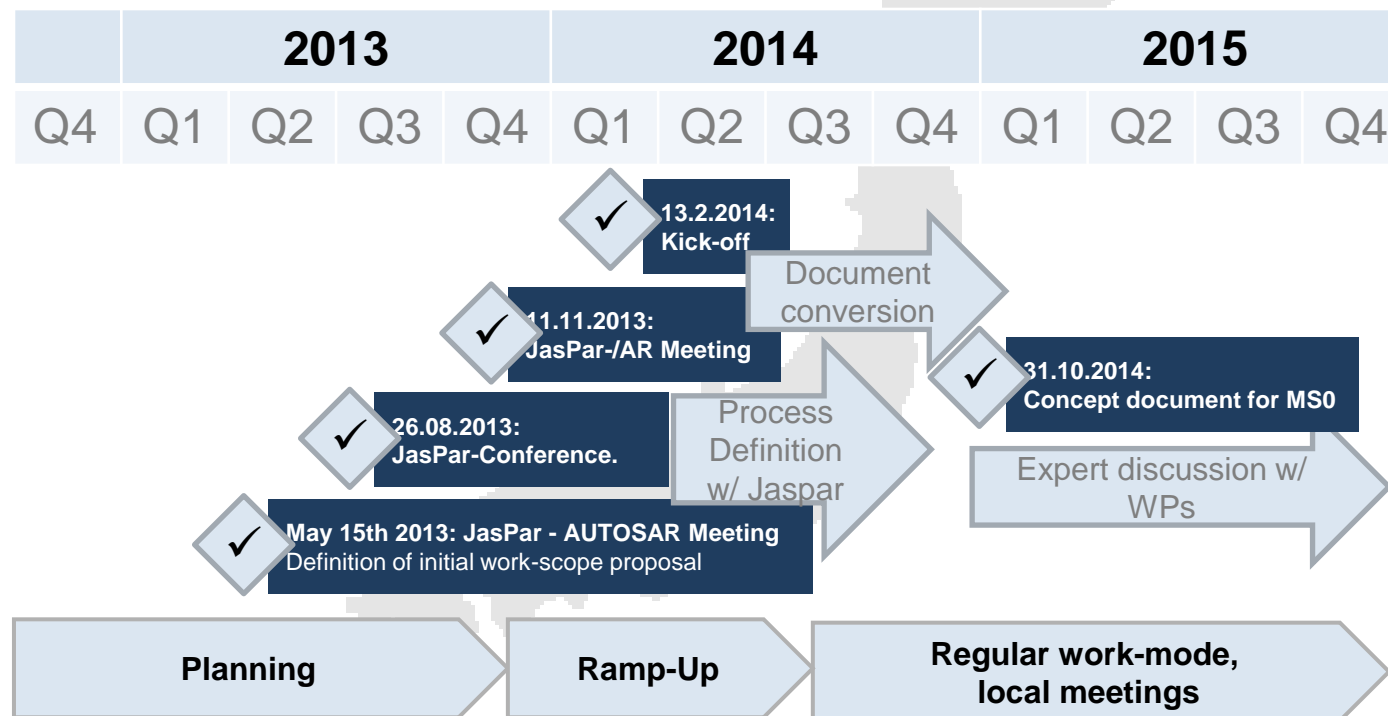

**Regional work package already started up as new organization**



## 5. BSW Functionality-ISO26262 Relation Analysis



- To fulfill the ISO requirements with AUTOSAR, JASPAR suggests the following:
  - ① For ISO requirement (Correcting Codes for Data) : Add “EDC” feature to E2E library
  - ② For ISO requirement (Error detecting codes) : Extend XCP module

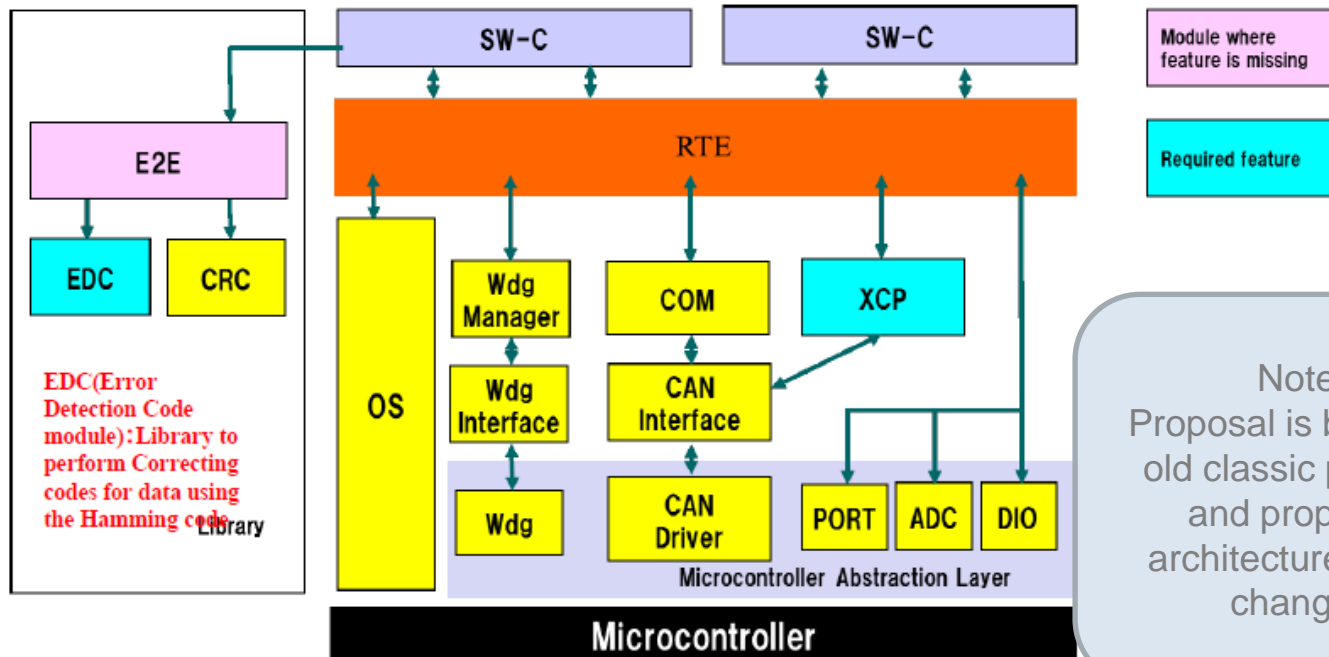

One functional safety topic was picked up as pilot project

## Outcome & Next steps

### Technical perspective

- Concept document consolidation
- JasPar document has been converted to Classic Platform R4.3.0 concept as pilot

### Management perspective

- Establishment of regular meeting (in total more than 30 meeting has been held)
- New process between WP-R-JP and JasPar has been in order to handle technical clarification. But it took much time than expected (lessons learned)
- Member becoming used to Autosar process (ex. Bugzilla, concept handling) step by step
- Easier participation makes every member motivated and keep good resource situation

### Next Steps

- Other activities e.g. Autosar adaptive platform, security

## *Message to potential contributors*

- Autosar Regional Work Package Japan has started focusing on JasPar requirement bridge
- Local companies who may have Autosar business are really appreciated

**Thank you very much for listening**  
**ご清聴ありがとうございました**  
**新規メンバのご参加お待ちしております**