

Achievements and exploitation of the AUTOSAR development partnership

Helmut Fennel, Stefan Bunzel, Continental
Harald Heinecke, Jürgen Bielefeld, Simon Fürst, BMW Group
Klaus-Peter Schnelle, Walter Grote, Nico Maldener, Bosch
Thomas Weber, Florian Wohlgemuth, Jens Ruh, DaimlerChrysler
Lennart Lundh, Tomas Sandén, Ford Motor Company
Peter Heitkämper, Robert Rimkus, General Motors
Jean Leflour, Alain Gilbert, PSA Peugeot Citroën
Ulrich Virnich, Stefan Voget, Siemens VDO
Kenji Nishikawa, Kazuhiro Kajio, Toyota Motor Corporation
Klaus Lange, Thomas Scharnhorst, Bernd Kunkel, Volkswagen

AUTOSAR Partnership

Copyright © 2006 CTEA

ABSTRACT

Reductions of hardware costs as well as implementations of new innovative functions are the main drivers of today's automotive electronics. Indeed more and more resources are spent on adapting existing solutions to different environments. At the same time, due to the increasing number of networked components, a level of complexity has been reached which is difficult to handle using traditional development processes.

The automotive industry addresses this problem through a paradigm shift from a hardware-, component-driven to a requirement- and function-driven development process, and a stringent standardization of infrastructure elements. One central standardization initiative is the AUTomotive Open System ARchitecture (AUTOSAR). AUTOSAR was founded in 2003 by major OEMs and Tier1 suppliers and now includes a large number of automotive, electronics, semiconductor, hard- and software companies. AUTOSAR aims at facilitating the re-use of soft- and hardware components between different vehicle platforms, OEMs and suppliers. To achieve this, AUTOSAR defines a methodology that supports a distributed, function-driven development process and standardizes the software-architecture for each ECU in such a system. AUTOSAR also specifies compatible software-interfaces at application-level.

This paper gives an overview of the AUTOSAR initiative, its goals, partners and members, and roadmap. It describes the AUTOSAR concepts, highlights the achievements to-date and the challenges ahead.

INTRODUCTION

The AUTOSAR development partnership is now in place for more than three years. The initial contract was signed mid of 2003 between the core partners. Since that time AUTOSAR created detailed specifications, which can be used directly to market new software products for automotive applications.

AUTOSAR is now in the transition between phase I and phase II. Phase I will end December 2006 with a mature specification set Release 2.1. A follow-up contract for phase II is signed with a clear definition of goals and objectives for another 3 years.

The re-use of software components between different vehicle platforms, OEMs and suppliers is one of the major goals of AUTOSAR. Therefore a methodology supporting a distributed, function-driven development process was created. Standardization of the software architecture for ECUs forming a network in an automotive environment is essential. AUTOSAR also specifies compatible software interfaces at application level, although the functional contents of the application modules and components are different and related to the corporate identity and the desired characteristics of the car manufacturer, or its system suppliers. By using the abstraction it will be possible to separate software from hardware in a complex decentralized network, which brings benefit in many directions:

- Management of E/E complexity associated with growth in functional scope
- Flexibility for product modification, upgrade and update
- Scalability of solutions within and across product lines
- Improved quality and reliability of E/E systems

Electronics and software represent a continuously increasing share in the added value of automotive products. Up to 90% of all automotive innovations are related to E/E. Increasing demands in vehicle safety, driver assistance, and comfort drives this trend. In addition legal requirements or environmental needs can only be fulfilled by using electronic hard- and software extensively (cp. [5]). All vehicle domains are affected. As a consequence, the complexity of automotive E/E architectures is growing exponentially (cp. [2]). Semiconductor and computer industries continue to improve performance and cut the costs of their components within short time intervals. Coming from mechanical, via electronic hardware oriented, function tailored devices, the functionality is nowadays defined by software which is embedded in its hardware environment. Therefore the automotive industry could only partly benefit from the semiconductor innovation process. The continuously increasing artificial intelligence, distributed all over the vehicle requires coping with new challenges. In addition the differentiation between power- and data-networks will lead to new and increased requirements, especially in the area of hybrid vehicles. All this leads to a hierarchical topology in the passenger car with domains, systems, sub-systems, and components. The data networks utilized by bus-systems are the backbone of such an architecture. Below this we find the architecture of the controllers themselves.

The automotive industry has recognized that a technological breakthrough is required and the development and standardization of an AUTomotive Open System ARchitecture (AUTOSAR) should address these challenges. Since these issues cannot be handled by individual companies with the goal to create a standard, the approach was to include as many players as possible into these efforts to be jointly successful in creating an international standard, which is beneficial for all.

THE AUTOSAR PROJECT

GENERAL GOALS

The AUTOSAR partnership aims to establish a standard which serves as a platform for future vehicle applications and will be implemented and serve to minimize the current barriers between functional domains (vehicle centric versus passenger centric). During the first phase AUTOSAR has been emphasizing the domains powertrain, chassis, active and passive safety, and body and comfort. Applied to these functional domains, the main common objectives are:

- Consideration of availability and safety requirements.
- Scalability to different vehicle and platform variants.
- Implementation and standardization of basic system functions as an OEM and supplier wide “Standard Core” solution.
- Transferability of functions throughout network.
- Integration of functional modules from multiple suppliers.
- Maintainability throughout the whole “Product Life Cycle”.
- Increased use of “Commercial off the shelf hardware”.
- Software updates and upgrades over vehicle lifetime.

The AUTOSAR approach is intended to lead to a real “win-win” situation for all involved parties, which is shown in Fig. 1. The change from proprietary solutions to a general standard will enable the following general benefits:

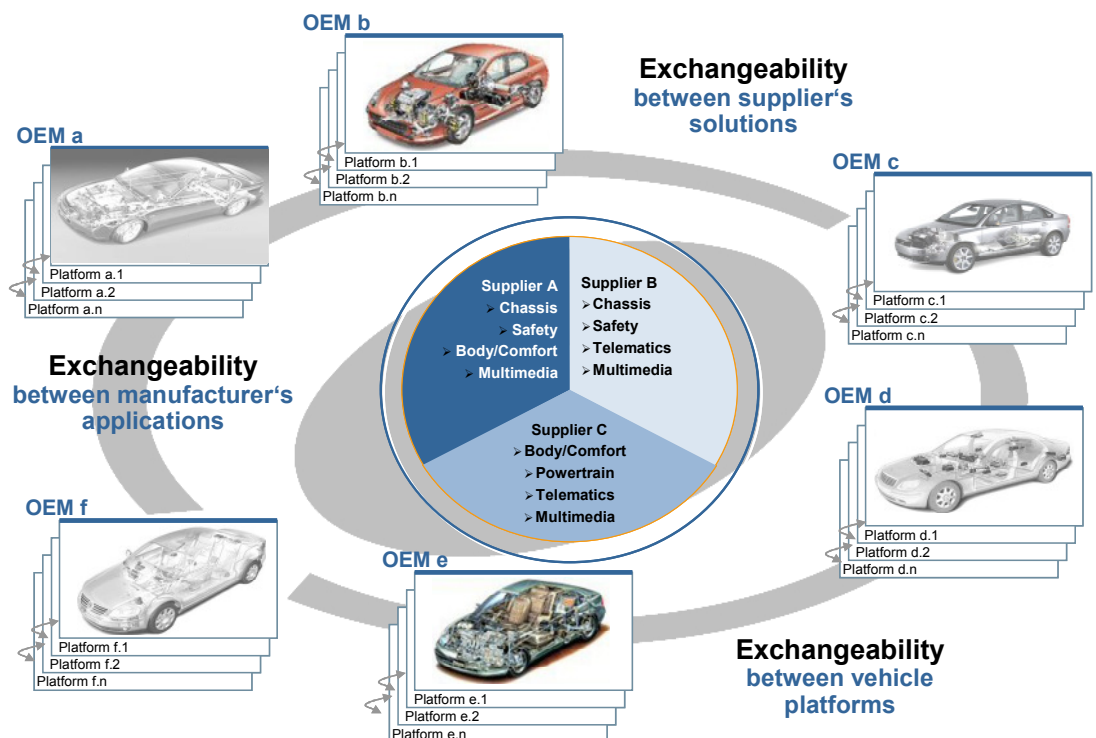

Fig. 1: Benefits from AUTOSAR

- Increased reuse of software.
- Increased design flexibility.
- Clear design rules for integration.
- Reduction of costs for software development and service in the long term.
- OEM overlapping reuse of non-competitive software modules.
- Focus on protected, innovative and competitive functions.

In addition to these general advantages for all parties involved in the vehicle design process, some specific benefits for each group can be achieved (cp. [4]).

Specific benefits for OEMs:

- Functions of competitive nature can be developed separately.
- Later sharing of innovations is accessible.
- Standardized conformance process.

Specific benefits for suppliers:

- Reduction of version proliferation.
- Development sharing among suppliers.
- Increase of efficiency in functional development.
- New business models.
- Preparation for upcoming increase in software volume.

Specific benefits for tool providers:

- Common interfaces with development processes.
- Seamless, manageable, task optimized (time dependent) tool landscape.

Specific benefits for new market entrant:

- Transparent and defined interfaces enable new business models.
- Clear contractual task allocation and outsourcing of Software-Implementation accessible.

Beneath the benefits described above AUTOSAR focuses on main strategic targets as modularity, configurability and transferability of software modules, and the standardization of their interfaces (cp. [4]) to accomplish the project objectives.

PROJECT ORGANIZATION AND PROJECT MANAGEMENT

The partnership consists of more than 100 companies. These are organized in several forms of cooperation, such as core partner (10), premium member (51), development member (1) and associate member (41) (status July 2006, for up-to-date information see [1]).

The core partners (see Fig. 2) are steering the project and have organizational and administrative responsibility

and control. They built up a distributed virtual organization with unanimity-based decision processes.



Fig. 2: The AUTOSAR core partners

The current premium members are shown in Fig. 3. In addition to the core partners the premium members are actively contributing to the creation of the standard. The contribution of this high amount of premium members to the daily work within the project has been an important factor to the success of the project.



Fig. 3: The AUTOSAR premium members

The associate members (see Fig. 4) represent users of the AUTOSAR standard. They receive all finalized documents in advance to the public, but they don't contribute actively to the standardization.



Fig. 4: The AUTOSAR associate members

In summary (combining core partner and premium member efforts) approximately 650 experts are currently contributing to the development of the standard, representing a full time equivalent of 175 staff. This places high demands on effective and efficient project and resource management, accurate reporting, quality assurance and transparent communication. Fig. 5 displays some impressive data regarding efforts and outcome so far.

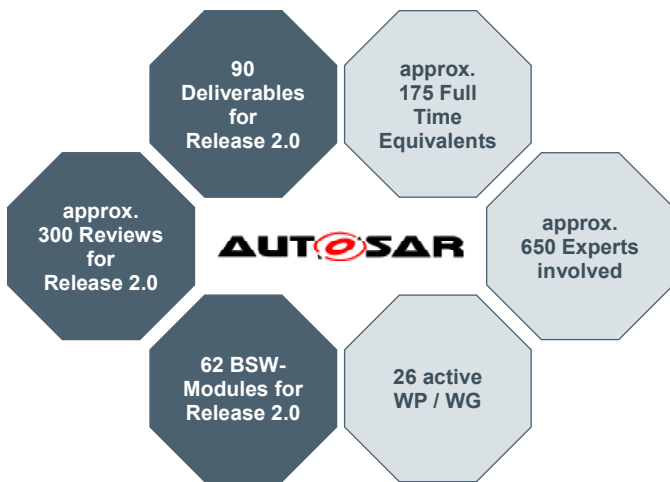

Fig. 5: Some AUTOSAR data

Since a very ambitious time schedule for the project was elaborated, the specification work of the standard is done in parallel, whenever possible. Intensive communication is required to ensure that the results from the work packages fit together.

A formal review process based on a 4-milestones concept is established for each deliverable in order to guarantee high quality and consistency of all resulting specifications. After passing milestone 4, the final version of a specification is owned by the Change Control Board.

THE AUTOSAR TECHNICAL CONCEPT

Remembering the first software controlled applications in passenger cars, it was only possible to fulfill limited tasks due to poor resources which could be offered by single chip microprocessors, used for cost reasons. The software programs were mostly written in assembly language and were highly optimized regarding size and runtime. With increasing functionality, a larger number of ECUs, communication between ECUs, and sensor- and function sharing appeared. The wish for more software structuring came up. In addition it was required more and more to run the identical software on different hardware platforms. So standardized operating systems, like OSEK, network management methods, and low-level drivers were introduced. This led to different implementations at OEMs and Tier1s.

The need to concentrate on a common stack of infrastructure software is addressed by AUTOSAR, with a well specified, standardized basic software, which closes the gap between microcontroller hardware and application software. The technical concept of the AUTOSAR approach is a layered model, which is new in the software design for automotive applications (cp. [6]).

By introducing a “Virtual Functional Bus” (VFB) it was possible to separate applications from infrastructure. An application consists of interconnected “AUTOSAR Software Components” (SW-Cs). The VFB (shown in the top part of Fig. 6) provides standardized communication

mechanisms and services for these components. The VFB acts independently from the chosen mapping of these components to the infrastructure of the interconnected ECUs (shown in the bottom part of Fig. 6).

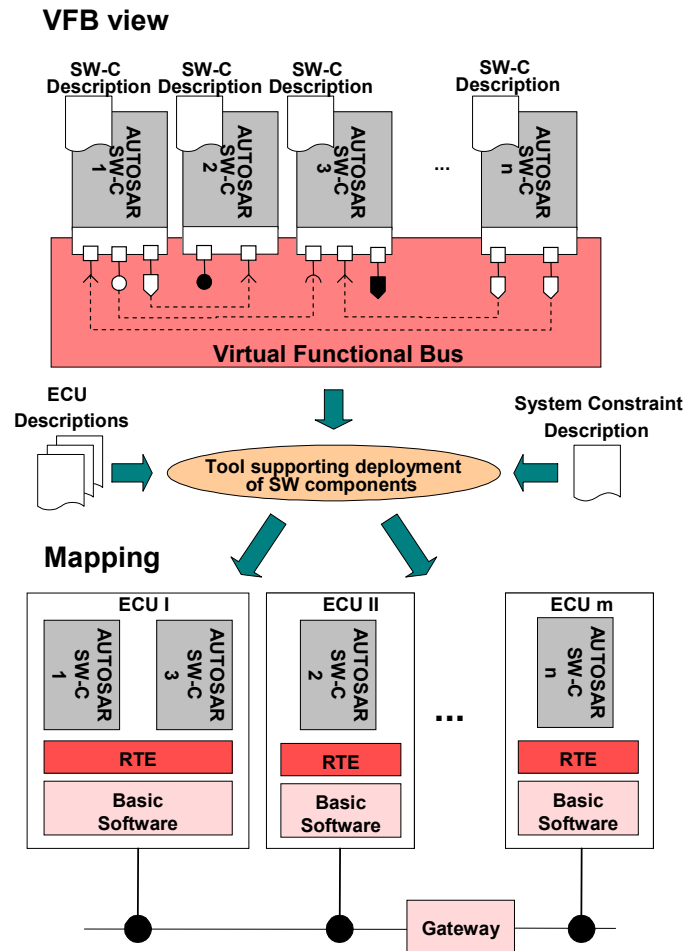

Fig. 6: The “virtual functional bus” (VFB) decouples application and infrastructure

The realization of the VFB concept is possible if each AUTOSAR ECU has standardized basic software functionalities and interfaces. Fig. 7 shows the layered architecture of an AUTOSAR ECU, which basically identifies an application layer, and the AUTOSAR Basic Software (BSW). These parts are linked via the AUTOSAR Runtime Environment (RTE). That means the RTE can be interpreted as the runtime implementation of the VFB on a specific ECU. In principle this layer model is applicable to nearly all vehicle domains.

AUTOSAR software components which are mapped to a specific ECU are located in the ECU’s application layer. The implementation of such an AUTOSAR SW-C is independent from microcontroller and ECU as well as from the physical location of other components in the system. An AUTOSAR SW-C interacts with other SW-Cs (on the same or different ECUs) and with the services and resources available on the ECU via the RTE. The RTE decouples the application SW-Cs from the infrastructure software.

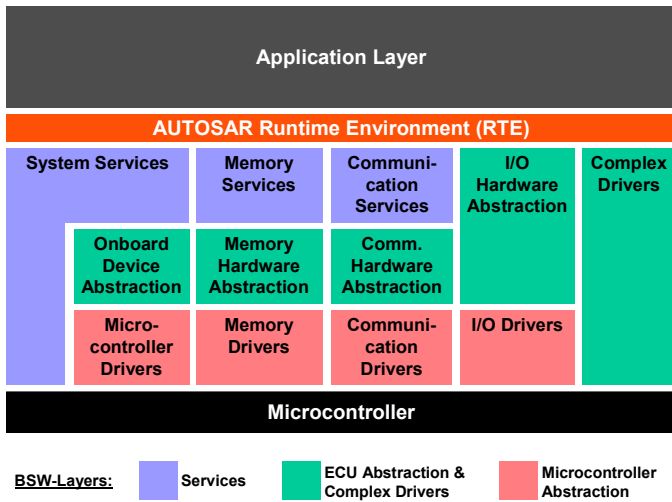

Fig. 7: The AUTOSAR ECU layered architecture

The BSW below the RTE provides the additional non-functional services. To distinguish between HW-dependent and HW-independent functionalities, the BSW is divided into the following layers:

- Services Layer
- ECU Abstraction Layer
- Microcontroller Abstraction Layer
- Complex Drivers

The Services Layer provides system services such as diagnostic protocols, non-volatile memory management, ECU mode management and operating system. Except for the operating system, the modules belonging to the Services Layer are HW-independent. The ECU Abstraction Layer abstracts the ECU layout (i.e. how peripherals are connected to the CPU) from the layers above. Although this layer is ECU specific, it is independent from the microcontroller. This independence is achieved by the Microcontroller Abstraction Layer, which contains microcontroller-specific drivers such as I/O drivers to control digital inputs or outputs and ADC-drivers to convert analogue signals to digital values. Modules that handle complex sensors and actuators with strong real time or specific electromechanical hardware requirements cannot be standardized within AUTOSAR. Here specific knowledge and intellectual property of OEMs and suppliers are affected which could be competition related, because it enables the companies to design their products in a cost effective way, such as compensation of nonlinearities in the sensor and actuator areas. These particular modules are located in the Complex Drivers Layer, however with the strong boundary conditions of performing AUTOSAR interfaces.

THE AUTOSAR SPECIFICATION STATUS

Looking at the structure of the AUTOSAR project three focus points can be identified:

- Basic software and RTE
- Templates and data exchange formats
- Functional interfaces on application layer

Up to now AUTOSAR has put its main focus on the subject of basic software and RTE. In contrast to the application software which is a core competence of OEMs and system suppliers and which creates the externally visible brand value, the underlying basic software has no features which are directly competition related and thus there is a high potential for standardization in this part of automotive software.

AUTOSAR RELEASE 1.0

In 2005 the first set of 57 deliverables (specifications) was released within the AUTOSAR community as „Release 1.0“. The main intention for the first release was to evaluate and mature the specifications by doing a first implementation: The Validator 1.

Within this validation activity 14 members of AUTOSAR shared the work and implemented the first set of specifications on two different hardware platforms. The hardware dependent software modules have been implemented once per platform, while the hardware independent software modules had been implemented twice in order to have a direct proof of exchangeability of these modules.

During the validation activities more than 260 change requests to the specifications came up. But only a very few of them caused conceptual changes. This is a clear sign for the efficiency and the effectiveness of the specification work and the outstanding architectural approach.

AUTOSAR RELEASE 2.0

The experience, made during the work with the Validator 1 had direct influence and feedback to the working groups dealing with Release 2.0. The extensions and contents from the Release 1.0 and 2.0 are shown in Fig. 8. In Release 2.0 several modules from Release 1.0 have been updated and missing modules from the following areas had been added:

- LIN support
- Function Inhibition Manager
- ECU State Manager
- Communication Manager
- Watchdog Manager
- I/O Hardware Abstraction

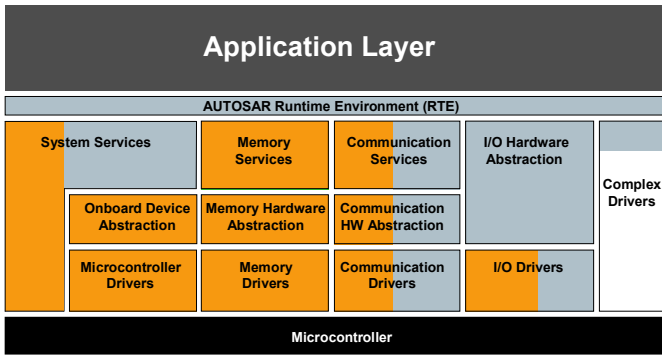

Legend: ■ AUTOSAR Release 1.0 ■ AUTOSAR Release 2.0
 Fig. 8: The AUTOSAR release content of R1.0 and R2.0

Since in Validator 1 the configuration was still specific, a standardized configuration concept was introduced in Release 2.0. For this purpose a generic configuration editor and in addition the Runtime Environment (RTE), as the link between basic software and applications, were specified.

To prove this enlarged set of specifications issued by Release 2.0, another validation – the Validator 2 – was built up. Here 12 implementers and 1 integrator are cooperating in a close relationship.

Major parts of the Release 2.0 specifications are now available for free download (on an information only basis) from the AUTOSAR website [1]. This publication shall prepare the exploitation phase. However, any commercial exploitation of the specifications partly or complete, requires an AUTOSAR membership.

AUTOSAR RELEASE 2.1

The work with and experiences gained from Validator 2 is the basis for Release 2.1. This release improves the BSW configuration concept by considering the link between standardized BSW configuration parameters of different BSW modules.

Release 2.1 has to be treated as the most mature AUTOSAR product, a well documented set of specifications, enabling the automotive industry to design entire E/E vehicle architectures by using the standard and being successful in vehicle launches.

INNOVATIONS AND LESSONS LEARNED

By validating the Release 2.0 the core partners and premium members, who were actively involved gained many experiences with the novelties introduced by AUTOSAR.

The AUTOSAR Basic Software contains well known infrastructure elements, but also many new and innovative ones, such as configuration and error handling (see Fig. 9). The major achievement is that for the first time a comprehensive (and domain spanning)

infrastructure is available now that consolidates and complements the know-how and experiences from carmakers and suppliers around the globe (cp. [3]).

In addition to the explanations in the section “The AUTOSAR Technical Concept” the following sections describe some of the new concepts in more detail.

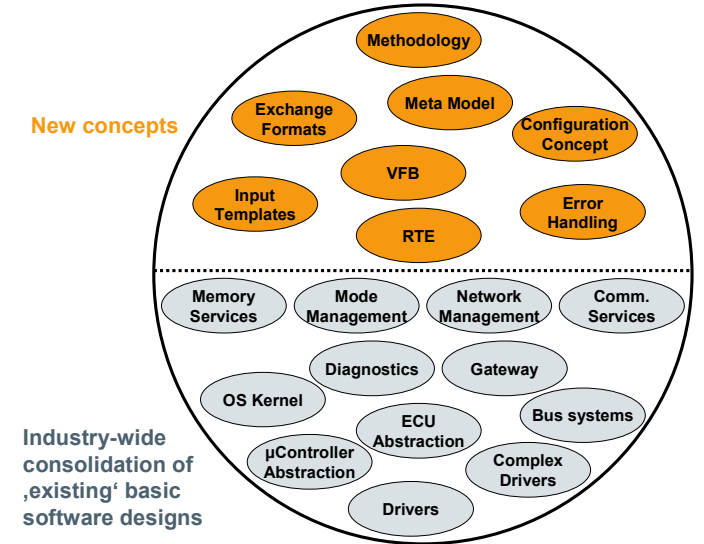

Fig. 9: Technical scope of the AUTOSAR standard

RUNTIME ENVIRONMENT (RTE)

The RTE is the run-time implementation of the VFB on a specific ECU. The notion of the VFB translates to all communication layer mechanisms that are relevant to the application layer software. The RTE abstracts the application layer from any implementation details of the basic software and hardware aspects. With this in mind, the RTE is a novel middleware layer technology that enables transferability of application layer software components across a distributed network.

Fig. 10 shows an example of the communication mechanism between application layer software components (see also Fig. 6 for comparison). The SW-Cs use ports which implement the interface according to the communication paradigm (here client-server based).

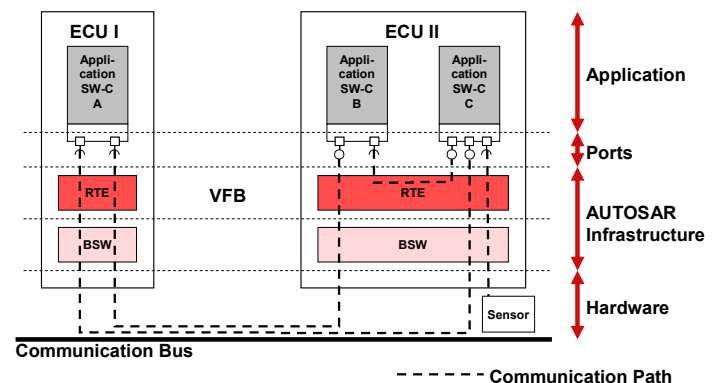

Fig. 10: Communication via RTE ports

That means ports are the interaction points of a component. The communication is channeled via the RTE; the communication layer in the basic software is encapsulated and not visible at the application layer.

AUTOSAR defines a standardized component model consisting of a clear programming language mapping (syntactically) and a file format for component requirement and capability description.

With this component model consisting of both communication mechanisms and scheduling related concepts the RTE allows the decomposition of the application software into well-structured coupled components.

These components can be moved across ECUs during concept phase or reused across projects (ideally without touching the source code), thus reducing engineering and testing effort significantly.

META MODEL & METHODOLOGY

AUTOSAR has developed a meta model which precisely defines the concepts used to describe a self-contained AUTOSAR system and a methodology which describes the major development steps of such a system. The input templates (based on XML) for describing an entire AUTOSAR system with software components, ECU resources, and system constraints, are directly derived from this meta model. Thus they are inherently consistent.

Within the AUTOSAR methodology all subsequent development steps up to the generation of executable code are supported by defining exchange formats and work methods for these steps. Whilst the methodology is not a complete process description itself, it can be applied as a basis for shared development processes. In analogy to the benefits of compatible technical interfaces, the methodology has the potential to enable synergies and improved effectiveness when applied properly in a collaborative business context.

EXTENDED CONFIGURATION CONCEPT

The AUTOSAR configuration concept supports multiple configuration variants. It allows pre-compile, link-time, and post-build parameters configuration classes or a combination thereof.

AUTOSAR defines formats to describe the capabilities and parameters of basic software modules including XML schema definitions. Using those descriptions, a generic editor (see Fig. 11) can be used to configure all software modules compiled into an ECU. This concept enables editor vendors to include convenience functions and consistency checks into their products that are impossible today and will boost development speed and product quality.

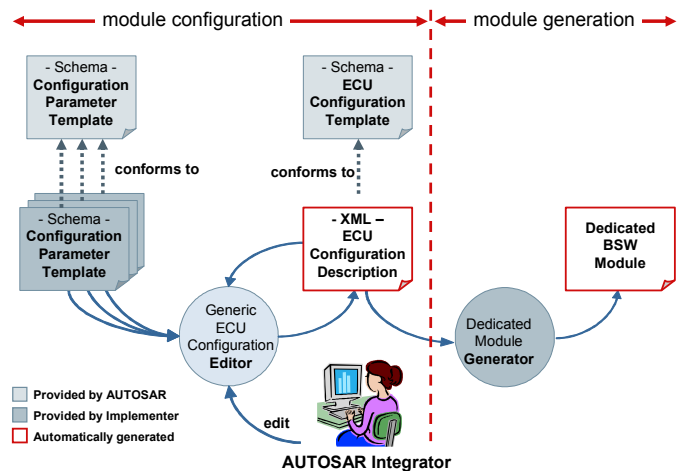

Fig. 11: The Generic Configuration Editor

The AUTOSAR specifications for basic software modules allow module vendors to offer multiple modes of module configuration. A BSW module can be designed using configuration at

- pre-compile time for best runtime performance,
- post-build time for highest flexibility and for avoiding a recompilation or rebuild of the ECU software due to configuration, or
- link time to achieve a trade-off between the two borders.

Configuration at pre-compile time and at link time utilizes code generation based on module configuration description files created by the generic editor as described above.

AUTOSAR supports the way towards an integrated and tightly coupled tool chain for automotive software development.

ERROR HANDLING

A consistent and non ambiguous error handling supports effective communication to application layer functionality and can also be used as a means for mode management and diagnostic purposes. Use cases include broken sensors, communication errors and memory failures.

For both, the basic software modules and the RTE, mechanisms are defined to propagate error information throughout the system. Therefore all API functions return error codes that are well defined in the basic software modules specifications respectively in the descriptions of the application software components.

An identified diagnostic event can be resolved directly in the client module or escalated towards upper software layers. Additionally any diagnostic event occurrences are reported to one of the two error handling facilities provided by the AUTOSAR basic software (see Fig. 12).

The first facility, the development error tracer (DET) is utilized to report diagnostic events that are of interest only during the integration or implementation phase. The DET can be configured by the system integrator to report diagnostic events by any desired means and is disabled during normal operation.

Diagnostic events that shall be monitored during normal operation are reported to the diagnostic event manager (DEM) which can be configured to enter the event occurrence into the diagnostic event memory and to change the mode of operation or inhibit an arbitrary functionality of the application software.

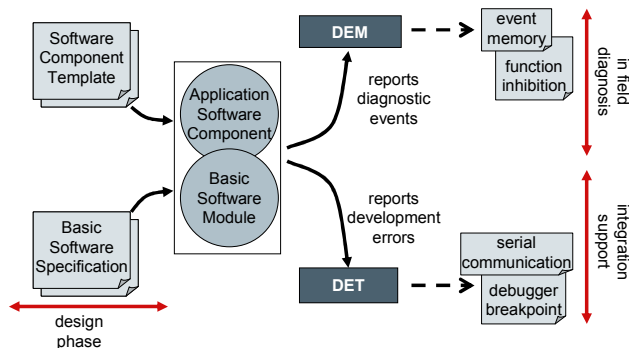

Fig. 12: Diagnosis during development and normal operation

THE APPLICATION SOFTWARE

In addition to the standardization of the infrastructure it is advantageous to develop a classification strategy to deal with competitive functionality at application level. Of course, unanimity between AUTOSAR partners has to be secured for both, the level of details of the interface description (which has to be standardized) and the level of functional breakdown. At present, AUTOSAR focuses on body, powertrain and chassis domains. A subset of functional interfaces has been standardized to agreed levels in each domain, e.g. external light, wiper/washer, driver request and adaptive cruise control.

AUTOSAR SUPPORT FOR FUNCTIONAL SAFETY

As functional safety has an important impact on the software architecture of automotive E/E systems, AUTOSAR has to focus on that topic. Therefore a Safety Team was established to address this issue comprehensively. The main concern of the Safety Team is to support the development of safety-related functionality by providing safety guidelines and specifying technical support that shall be implemented in the AUTOSAR framework. Details of this work are presented in [7].

AUTOSAR CONFORMANCE TESTING

OBJECTIVE AND SCOPE

Products, using the AUTOSAR trademark represent conformity to the AUTOSAR specifications. To guarantee this right from the beginning of the AUTOSAR venture

means for quality assurance were discussed and incorporated into the work packages.

AUTOSAR has defined a conformance test process. The conformance testing shall verify that a product under test adheres to the corresponding AUTOSAR specifications. Ultimately, this is a condition for interoperability, re-use/portability and scalability of those products that have successfully demonstrated their conformance to the AUTOSAR standard.

As the AUTOSAR specifications standardize basic software modules, the run-time environment, and basic interface features of application software components, such products are the subjects of conformance testing. AUTOSAR core partners, premium, development and associate members who have proven the conformance for their products via the conformance test process are allowed to use the AUTOSAR trademark for this product.

THE CONFORMANCE TEST PROCESS

The AUTOSAR conformance test process was designed for suiting to broad diversity of possible development and business scenarios with AUTOSAR products. The process distinguishes two basically different approaches, see Fig. 13. On the one hand there is an external conformance attestation by a 3rd party – a conformance test agency (CTA) which has to be accredited. On the other hand there are internal procedures within a product supplier leading to a self-declaration of conformance. Such a product supplier will have to be accredited in a comparable manner as a CTA.

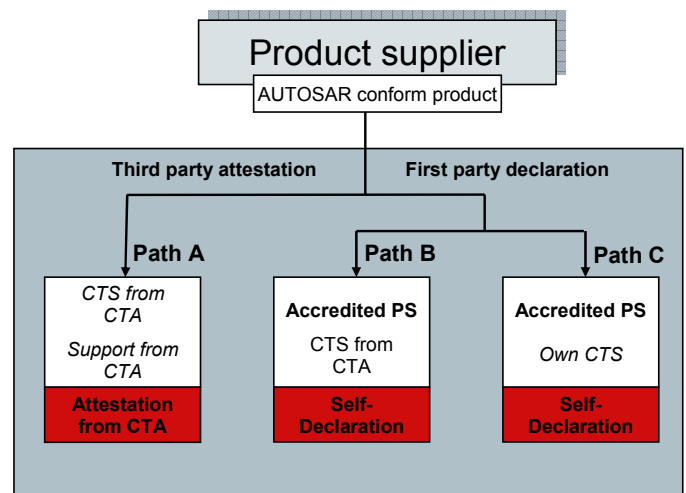

Fig. 13: AUTOSAR Conformance Test Paths

From a practical point of view the product under test has to pass standardized test cases which will be executed against a conformance test suite (CTS). The CTS implements the conformance test specifications.

The conformance test process will be established during 2007. Currently AUTOSAR prepares the selection of accreditation bodies and assessors who then shall start the accreditation of CTAs and product suppliers. Up to

this time a company internal self declaration is mandatory to market products, which utilize the AUTOSAR specifications.

AUTOSAR PHASE II (2007-2009)

FINALIZATION OF AUTOSAR PHASE I AND TRANSITION TO AUTOSAR PHASE II

At the end of 2006 the AUTOSAR project will finish phase I and actively enter phase II. The succeeding subsections emphasize on the situation of finalizing phase I and the major challenges for phase II.

With the last milestone of phase I in December 2006 AUTOSAR will have achieved mature specifications of methodology, templates, basic software, and RTE.

Consequentially each AUTOSAR core partner has developed its own exploitation plans. Already in 2008 the first cars with AUTOSAR technology inside will appear on the market. And all core partners have planned the introduction of AUTOSAR products until 2010. This emphasizes clearly that the standard is well accepted and that AUTOSAR products will become reality in the near future.

Furthermore the released specifications have been published. The purpose of this publication is to:

- Promote AUTOSAR as de-facto standard
- Allow for open communication on specifications and AUTOSAR contents
- Attract new members

In any case, the exploitation of the AUTOSAR standard requires membership.

The crucial role that AUTOSAR has been taken in the automotive industry is the main motivation for continuing the project with phase II. The core partners have agreed to continue with a formal project partnership as it has been set up for phase I for another three years.

CONTENTS OF AUTOSAR PHASE II

The activities in phase II basically can be distinguished in a) the exploitation and maintenance of the outcome of phase I and b) the further development of the standard. Fig. 14 shows the work package structure of AUTOSAR phase II.

Regarding exploitation and maintenance there is already established a release process for future releases and a change management for further improvements of the standard. Moreover the handling of conformance tests has been organized (see section "The Conformance Test Process"). This is a very important aspect for production application of AUTOSAR. It affects the BSW modules (e.g. AUTOSAR OS, communication manager, RTE), and the compatibility between application software components and RTE.

Besides these activities the further development and amendment of the standard shall be driven. This will incorporate the experiences from the validation at the end of phase I and generally consider feedback from all AUTOSAR stakeholders. And also additional safety features shall be in focus of phase II.

Last but not least the AUTOSAR interfaces of many application software functions (e.g. central locking, power train control, adaptive cruise control, etc.) will be standardized in phase II. As a prerequisite the AUTOSAR partnership works on an appropriate decomposition for such functionalities. For many of them this already has been achieved, but this also will be the task of AUTOSAR work packages in phase II. In particular the work packages dealing with passenger & pedestrian (P & P) safety systems and multimedia /telematics are completely new in phase II. The interface standardization not only means a further development, it also supports the exploitation, because it will ease the exchange of application software between OEMs and suppliers.

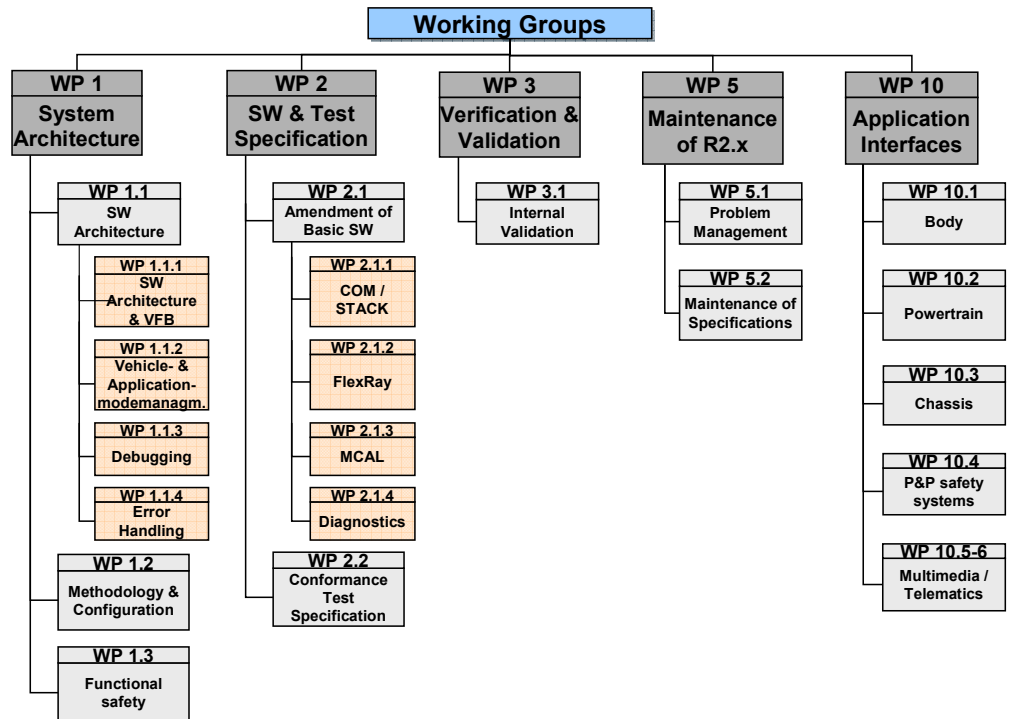

Fig. 14: AUTOSAR phase II work package structure

PREPARATIONS FOR PHASE II

Due to the challenging development program and the work on additional domains like telematics/multimedia the core partners agreed to extend to AUTOSAR phase II by another three years. This leads consequently to a prolongation of the development partnership.

With respect to the described forms of membership and the contract there will be no basic changes but adaptation of the contract regarding the goals and objectives for phase II.

This is an excellent opportunity for new members to join phase II, since the standard is well defined and established. On the other hand new and additional tasks in phase II, like multimedia, telematics, etc. may attract companies, working already in these areas, but saw until now no or little coverage by the AUTOSAR concept. Therefore an updated information package is available on the AUTOSAR web (see [1]).

CONCLUSION

Since the start of the AUTOSAR activities a high amount of work had been done to create the standard and to make it mature enough for industry wide applications. This was done by a global effort of international working companies having not only worked out a "l'art pour l'art" specification, but one which can find its application instantaneously in modern automobiles. All this was done in the given timeframe, with different partners, different competitors, different nationalities, and different opinions. Merging and converging all these differences alone is a major challenge.

The outcome is obvious. The specification work is one of the best documented worldwide in the automotive software area. This success is not only based on work of the core partners, it could only be achieved by extensive contribution of the AUTOSAR premium members. Despite the fact that most of the AUTOSAR members are competitors in daily business, the collaboration in the work groups developed very fruitful.

So, the AUTOSAR venture starts from a solid basis to the next step. The AUTOSAR infrastructure and methodology has all mandatory starting conditions for the exploitation phase, and will enable a multiple win situation from the design engineer, via the integrator, up to the end customer.

REFERENCES

- [1] www.autosar.org Official website of the AUTOSAR partnership
- [2] Fennel, Helmut et al.: Qualität und Markenidentität durch die AUTOSAR Standard Architektur. VDA Jahrestagung 2004, Rüsselsheim, March 2004
- [3] Heinecke, Harald et al.: AUTOSAR – Current results and preparations for exploitation. Euroforum conference May 3rd 2006
- [4] Heinecke, Harald et al.: AUTomotive Open System ARchitecture – An industry-wide initiative to manage the complexity of emerging Automotive E/E-Architectures. Convergence 2004, International Congress on Transportation Electronics, Detroit, 2004
- [5] Scharnhorst, Thomas: AUTOSAR – ein wichtiger Beitrag für die Automobilarchitekturen der Zukunft. Vision Automobil, Handelsblatt Jahrestagung Automobiltechnologien 2005, Munich, 2005
- [6] Scharnhorst, Thomas et al.: AUTOSAR – Challenges and Achievements 2005. Electronic Systems for Vehicles 2005, VDI Congress, Baden-Baden, 2005
- [7] Per Johannessen: AUTOSAR Safety Approach. Convergence 2006, Transportation Electronics Conference, Detroit, 2006 (this volume)

CONTACT

request@autosar.org

DEFINITIONS, ACRONYMS, ABBREVIATIONS

ADC: Analogue Digital Converter

BSW: Basic Software

CTA: Conformance Test Agency

ECU: Electronic Control Unit

E/E: Electric/Electronics

HW: Hardware

OEM: Original Equipment Manufacturer

RTE: Runtime Environment

SW-C: Software Component

VFB: Virtual Functional Bus

XML: eXtensible Mark up Language